

## 1-MB Flash, 256-KB SRAM with optional Hardware Security Module, Crypto, 1 MSPS 12-bit ADC, QSPI, USB, Ethernet, and PTC

### Operating Conditions (PIC32CX SG41)

- 1.71V - 3.63V, -40°C to +85°C, DC to 120 MHz
- 1.71V - 3.63V, -40°C to +125°C, DC to 100 MHz

### Operating Conditions (PIC32CX SG60/SG61)

- 2.7V - 3.63V, -40°C to +85°C, DC to 120 MHz
- 2.7V - 3.63V, -40°C to +125°C, DC to 100 MHz

### Core:

- Arm® Cortex®-M4F CPU running at up to 120 MHz:
  - 403 CoreMark® at 120 MHz
  - 4 KB combined instruction cache and data cache
  - 8-Zone Memory Protection Unit (MPU)
  - Thumb®-2 instruction set
  - Embedded Trace Module (ETM) with instruction trace stream
  - CoreSight Embedded Trace Buffer (ETB)
  - Trace Port Interface Unit (TPIU)
  - Floating Point Unit (FPU)

### Memories

- 1 MB in-system self-programmable Flash with:
  - Error Correction Code (ECC)
  - Dual bank with Read-While-Write (RWW) support
  - EEPROM hardware emulation
- 256 KB SRAM main memory
  - 128 KB with Error Correction Code (ECC) RAM option
- Up to 4 KB of Tightly Coupled Memory (TCM)
- 8 KB additional SRAM
  - Can be retained in backup mode
- Eight 32-bit backup registers

### Low-Power and Power Management

- Idle, Standby, Hibernate, Backup, and Off sleep modes
- SleepWalking peripherals
- Battery backup support
- Embedded Buck/LDO regulator supporting on-the-fly selection

### I/O

- Up to 99 programmable I/O pins

### Security and Safety

- One Advanced Encryption System (AES) with 256-bit key length and up to 2 MB/s data rate
  - ECB, CBC, CFB, OFB, CTR modes of operation
  - Supports counter with CBC-MAC mode
  - Galois Counter Mode (GCM)
- True Random Number Generator (TRNG)
- Public Key Cryptography Controller (PUKCC) and associated Classical Public Key Cryptography Library (PUKCL)
  - RSA, DSA
  - Elliptic Curves Cryptography (ECC) ECC GF(2n), ECC GF(p)
- Integrity Check Module (ICM) based on Secure Hash Algorithm (SHA1, SHA224, SHA256), DMA assisted
- Permanent protection against Chip Erase, Boot section Programming and Debug access, allowing Immutable Boot (optional)
- Size-configurable Immutable Boot section in Flash with Boot Read Protection, allowing secure boot support (optional)

### Hardware Security Module (optional)

- Secure boot support: Validation of host code image and host code signature validation
- Secure update support for host code: Secure encryption key storage and image decryption
- X.509 Certificate storage, parsing, validation and revocation, supporting both ECC and RSA
- High-speed SHA256, HMAC and AES-CMAC engines
- P224, P256 and P384 Elliptic Curve – ECDSA Sign/Verify
- ECDH support for P256 & P224 Curves
- ECBD support for P224 Curve
- SECP256K1 (Bitcoin/Blockchain curve) ECDSA support
- 256-bit Brainpool Elliptic Curve support – ECDSA, ECDH
- RSA - 2048 Sign/Verify, 3072 Verify, 1024 Encrypt/Decrypt
- 256 bit key generation and derivation
- 2048 bit RSA key generation and derivation
- Elliptic Curve Diffie Hellman (ECDH/ECDHE) Key Agreement
- NIST SP800-90 Random Number Generator (RNG)
- Internal symmetric and asymmetric key generation

**Peripherals**

- 32-channel Event System
- Eight Serial Communication Interfaces (SERCOM), each configurable to operate as either:
  - USART with full-duplex and single-wire half-duplex configuration
  - ISO7816
  - I<sup>2</sup>C up to 3.4 MHz
  - SPI with optional inter-byte space
  - LIN host/client
  - RS485
  - Hardware Security Module interface (optional)
- Eight 16-bit Timers/Counters (TC) each configurable as:
  - 16-bit TC with two compare/capture channels
  - 8-bit TC with two compare/capture channels
  - 32-bit TC with two compare/capture channels, by pairing two TCs
- Two 24-bit Timer/Counters for Control (TCC), with extended functions:
  - Up to six compare channels with optional complementary output
  - Generation of synchronized pulse width modulation (PWM) pattern across port pins
  - Deterministic fault protection, fast decay and configurable dead-time between complementary output
  - Dithering increasing resolution with up to 5 bit and reducing quantization error
- Three 16-bit Timer/Counters for Control (TCC) with extended functions:
  - Up to three compare channels with optional complementary output
- 32-bit Real Time Counter (RTC) with clock/calendar function
- Up to 5 wake-up pins with tamper detection and debouncing filter
- Watchdog Timer (WDT) with Window mode
- CRC-32 generator
- One two-channel Inter-IC Sound Interface (I<sup>2</sup>S)
- Position Decoder (PDEC)
- Frequency meter (FREQM)
- Four Configurable Custom Logic (CCL)
- Dual 12-bit, 1 Msps ADC with up to 16 channels each:
  - Differential and single-ended input
  - Automatic offset and gain error compensation
  - Oversampling and decimation in hardware to support 13-bit, 14-bit, 15-bit, or 16-bit resolution

**Peripherals continued...**

- Dual 12-bit, 1 Msps output DAC
- Two Analog Comparators (AC) with Window Compare function
- Parallel Capture Controller (PCC), up to 14 bits wide
- Peripheral Touch Controller (PTC)
  - Capacitive Touch buttons, sliders, and wheels
  - Wake-up on touch
  - Up to 32 self-capacitance and up to 256 mutual-capacitance channels

**High-Performance Peripherals**

- 32-channel Direct Memory Access Controller (DMAC)
  - Built-in CRC with memory CRC generation/monitor hardware support
- Two SD/MMC Host Controller (SDHC)
  - Up to 50 MHz operation
  - 4-bit or 1-bit interface
  - Compatibility with SD and SDHC memory card specification version 3.01
  - Compatibility with SDIO specification version 3.0
  - Compliant with JEDEC specification, MMC memory cards V4.51
- One Quad I/O Serial Peripheral Interface (QSPI)
  - eExecute-In-Place (XIP) support
  - Dedicated AHB memory zone
- One Ethernet MAC
  - 10/100 Mbps with dedicated DMA
  - IEEE<sup>®</sup> 1588 Precision Time Protocol (PTP) support
  - IEEE 1588 Time Stamping Unit (TSU) support
  - IEEE802.3AZ energy efficiency support
  - Support for 802.1AS and 1588 precision clock synchronization protocol
  - Wake on LAN support
- Two Controller Area Network (CAN)
  - Support for CAN 2.0A/CAN 2.0B and CAN-FD (ISO 11898-1:2015)
- One Full-Speed (12 Mbps) Universal Serial Bus (USB) 2.0 interface
  - Embedded host and device function
  - Eight endpoints
  - On-chip transceiver with integrated serial resistor

**System**

- Power-on Reset (POR) and Brown-out Detection (BOD)
- Internal and external clock options
- External Interrupt Controller (EIC)
- 16 external interrupts
- One non-maskable interrupt

**Clock Management**

- 32.768 kHz crystal oscillator (XOSC32K) with Clock failure detection
- Two 8 MHz to 48 MHz crystal oscillator (XOSC) with Clock failure detection
- 32.768 kHz ultra low-power internal oscillator (OSCULP32K)
- 48 MHz Digital Frequency Locked Loop (DFLL48M)
- Two 96-200 MHz Fractional Digital Phased Locked Loop (FDPLL200M)

**Software and Tools Support: Develop Prototypes Quickly With A Powerful, Easy-to-Use Ecosystem**

- Get the code off to a head start with MPLAB® Code Configurator
- Graphically configure peripherals, software libraries, and supported RTOS with MPLAB Harmony
- Download MPLAB XC Compiler
- Take advantage of MPLAB X IDE's support for 32-bit MCUs
- Select the best debugger for the project: MPLAB ICE, ICD, or PICKIT™

**Debugger Development Support**

- Two-pin Serial Wire Debug (SWD) programming and debugging interface
- Six hardware breakpoints and four data watchpoints

**Table 1. Packages**

Type	TQFP			TFBGA
Pin Count	64	100	128	100
I/O Pins (up to)	51	81	94/99 <sup>(1)</sup>	81
Contact/Lead Pitch (mm)	0.5	0.5	0.4	0.8
Dimensions Body (mm)	10x10x1.0	14x14x1.0	14x14x1.0	9x9x1.2

**Note:**

1. Up to 94 I/O pins for PIC32CX SG60/SG61. Up to 99 I/O pins for PIC32CX SG41.

## Table of Contents

1-MB Flash, 256-KB SRAM with optional Hardware Security Module, Crypto, 1 MSPS 12-bit ADC, QSPI, USB, Ethernet, and PTC .....	1
1. Configuration Summary.....	16
2. Ordering Information.....	17
3. Block Diagram.....	18
4. Pinout and Packaging.....	19
4.1. 64-pin TQFP.....	20
4.2. 100-pin TFBGA and 100-pin TQFP.....	26
4.3. 128-pin TQFP.....	34
4.4. IOSET Configurations.....	53
4.5. Oscillator Pinout.....	56
4.6. Supply Controller Pinout.....	57
4.7. RTC Pinout.....	57
4.8. Backup I/O Pins.....	57
5. Signal Descriptions List.....	59
6. Power Supplies.....	62
7. Device Start-Up.....	64
7.1. Power-Up Considerations.....	64
7.2. Clocks After Reset.....	64
7.3. Initial Instructions Fetching.....	64
7.4. I/O Pins.....	64
7.5. Power-on Reset and Brown-out Detector.....	64
8. Product Mapping .....	66
9. Memories.....	68
9.1. Embedded Memories.....	68
9.2. NVM Configuration Rows.....	71
9.3. Serial Number.....	72
10. Processor and Architecture.....	74
10.1. Cortex M4 Processor.....	74
10.2. Nested Vector Interrupt Controller.....	76
10.3. High-Speed Bus System.....	85
11. Cortex-M Cache Controller (CMCC).....	89
11.1. Overview.....	89
11.2. Features.....	89
11.3. Block Diagram.....	90
11.4. Peripheral Dependencies.....	91
11.5. Functional Description.....	91
11.6. DEBUG Mode.....	94
11.7. RAM Properties.....	94

11.8. Register Summary.....	95
12. Peripheral Access Controller (PAC).....	108
12.1. Overview.....	108
12.2. Features.....	108
12.3. Block Diagram.....	108
12.4. Peripheral Dependencies.....	108
12.5. Functional Description.....	109
12.6. Register Summary.....	112
13. Device Service Unit (DSU).....	141
13.1. Overview.....	141
13.2. Features.....	141
13.3. Block Diagram.....	141
13.4. Signal Description.....	141
13.5. Peripheral Dependencies.....	142
13.6. Debug Operation.....	142
13.7. Chip Erase.....	144
13.8. Programming.....	145
13.9. Intellectual Property Protection.....	145
13.10. Device Identification.....	146
13.11. Functional Description.....	147
13.12. Register Summary.....	152
14. Clock System.....	181
14.1. Clock Distribution.....	181
14.2. Synchronous and Asynchronous Clocks.....	182
14.3. Register Synchronization.....	183
14.4. Enabling a Peripheral.....	185
14.5. On Demand Clock Requests.....	185
14.6. Power Consumption vs. Speed.....	186
14.7. Clocks after Reset.....	186
15. Generic Clock Controller (GCLK).....	187
15.1. Overview.....	187
15.2. Features.....	187
15.3. Block Diagram.....	187
15.4. Signal Description.....	188
15.5. Peripheral Dependencies.....	188
15.6. Functional Description.....	189
15.7. Register Summary.....	194
16. Main Clock (MCLK).....	202
16.1. Overview.....	202
16.2. Features.....	202
16.3. Block Diagram.....	202
16.4. Peripheral Dependencies.....	202
16.5. Functional Description.....	204
16.6. Register Summary.....	209

17. 32.768 kHz Oscillators Controller (OSC32KCTRL).....	226
17.1. Overview.....	226
17.2. Features.....	226
17.3. Block Diagram.....	227
17.4. Signal Description.....	227
17.5. Peripheral Dependencies.....	227
17.6. Functional Description.....	228
17.7. Register Summary.....	233
18. Oscillators Controller (OSCCTRL).....	244
18.1. Overview.....	244
18.2. Features.....	244
18.3. Block Diagram.....	245
18.4. Signal Description.....	245
18.5. Peripheral Dependencies.....	245
18.6. Functional Description.....	246
18.7. Register Summary.....	259
19. Supply Controller (SUPC).....	287
19.1. Overview.....	287
19.2. Features.....	287
19.3. Block Diagram.....	288
19.4. Signal Description.....	288
19.5. Peripheral Dependencies.....	288
19.6. Functional Description.....	289
19.7. Register Summary.....	296
20. Power Manager (PM).....	312
20.1. Overview.....	312
20.2. Features.....	312
20.3. Block Diagram.....	312
20.4. Peripheral Dependencies.....	312
20.5. Functional Description.....	313
20.6. Register Summary.....	321
21. Reset Controller (RSTC).....	331
21.1. Overview.....	331
21.2. Features.....	331
21.3. Block Diagram.....	331
21.4. Signal Description.....	331
21.5. Peripheral Dependencies.....	331
21.6. Functional Description.....	332
21.7. Register Summary.....	334
22. Watchdog Timer (WDT).....	337
22.1. Overview.....	337
22.2. Features.....	337
22.3. Block Diagram.....	338
22.4. Peripheral Dependencies.....	338
22.5. Functional Description.....	339

22.6. Register Summary.....	344
23. Real-Time Counter (RTC).....	353
23.1. Overview.....	353
23.2. Features.....	353
23.3. Block Diagram.....	354
23.4. Signal Description.....	354
23.5. Peripheral Dependencies.....	355
23.6. Functional Description.....	356
23.7. Register Summary - Mode 0 - 32-Bit Counter.....	366
23.8. Register Summary - Mode 1 - 16-Bit Counter.....	387
23.9. Register Summary - Mode 2 - Clock/Calendar.....	409
24. Frequency Meter (FREQM).....	431
24.1. Overview.....	431
24.2. Features.....	431
24.3. Block Diagram.....	431
24.4. Peripheral Dependencies.....	431
24.5. Functional Description.....	432
24.6. Register Summary.....	435
25. Direct Memory Access Controller (DMAC).....	445
25.1. Overview.....	445
25.2. Features.....	445
25.3. Block Diagram.....	447
25.4. Peripheral Dependencies.....	447
25.5. Functional Description.....	448
25.6. Register Summary.....	473
25.7. Register Summary - SRAM.....	509
26. External Interrupt Controller (EIC).....	516
26.1. Overview.....	516
26.2. Features.....	516
26.3. Block Diagram.....	516
26.4. Signal Description.....	516
26.5. Peripheral Dependencies.....	517
26.6. Functional Description.....	518
26.7. Register Summary.....	524
27. Non-Volatile Memory Controller (NVMCTRL).....	539
27.1. Overview.....	539
27.2. Features.....	539
27.3. Block Diagram.....	540
27.4. Peripheral Dependencies.....	540
27.5. Functional Description.....	541
27.6. Register Summary.....	562
28. RAM Error Correction Code (RAMECC).....	585
28.1. Overview.....	585
28.2. Features.....	585

28.3.	Block Diagram.....	585
28.4.	Peripheral Dependencies.....	585
28.5.	Functional Description.....	586
28.6.	Register Summary.....	588
29.	I/O Pin Controller (PORT).....	595
29.1.	Overview.....	595
29.2.	Features.....	595
29.3.	Block Diagram.....	596
29.4.	Signal Description.....	596
29.5.	Peripheral Dependencies.....	596
29.6.	Functional Description.....	598
29.7.	Register Summary.....	604
30.	Event System (EVSYS).....	623
30.1.	Overview.....	623
30.2.	Features.....	623
30.3.	Block Diagram.....	623
30.4.	Peripheral Dependencies.....	624
30.5.	Functional Description.....	625
30.6.	Register Summary.....	632
31.	Serial Communication Interface (SERCOM).....	658
31.1.	Overview.....	658
31.2.	Features.....	658
31.3.	Block Diagram.....	658
31.4.	Signal Description.....	658
31.5.	Peripheral Dependencies.....	659
31.6.	Functional Description.....	661
32.	SERCOM Synchronous and Asynchronous Receiver and Transmitter (SERCOM USART).....	667
32.1.	Overview.....	667
32.2.	USART Features.....	667
32.3.	Block Diagram.....	668
32.4.	Signal Description.....	668
32.5.	Peripheral Dependencies.....	668
32.6.	Functional Description.....	669
32.7.	Register Summary.....	687
33.	SERCOM Serial Peripheral Interface (SERCOM SPI).....	712
33.1.	Overview.....	712
33.2.	Features.....	712
33.3.	Block Diagram.....	712
33.4.	Signal Description.....	713
33.5.	Peripheral Dependencies.....	713
33.6.	Functional Description.....	713
33.7.	Register Summary.....	723
34.	SERCOM Inter-Integrated Circuit (SERCOM I <sup>2</sup> C).....	741
34.1.	Overview.....	741



34.2.	Features.....	741
34.3.	Block Diagram.....	742
34.4.	Signal Description.....	742
34.5.	Peripheral Dependencies.....	742
34.6.	Functional Description.....	743
34.7.	Register Summary - I2C Client.....	765
34.8.	Register Summary - I2C Host.....	782
35.	Quad Serial Peripheral Interface (QSPI).....	800
35.1.	Overview.....	800
35.2.	Features.....	800
35.3.	Block Diagram.....	801
35.4.	Signal Description.....	801
35.5.	Peripheral Dependencies.....	801
35.6.	Functional Description.....	803
35.7.	Register Summary.....	819
36.	SD/MMC Host Controller (SDHC) .....	841
36.1.	Overview.....	841
36.2.	Features.....	841
36.3.	Block Diagrams.....	842
36.4.	Signal Description.....	843
36.5.	Peripheral Dependencies.....	843
36.6.	Functional Description.....	843
36.7.	Register Summary.....	844
37.	Inter-IC Sound Controller (I <sup>2</sup> S).....	916
37.1.	Overview.....	916
37.2.	Features.....	916
37.3.	Block Diagram.....	917
37.4.	Signal Description.....	917
37.5.	Peripheral Dependencies.....	918
37.6.	Functional Description.....	919
37.7.	I <sup>2</sup> S Application Examples.....	929
37.8.	Register Summary.....	932
38.	Control Area Network (CAN).....	949
38.1.	Overview.....	949
38.2.	Features.....	949
38.3.	Block Diagram.....	950
38.4.	Signal Description.....	950
38.5.	Peripheral Dependencies.....	950
38.6.	Functional Description.....	951
38.7.	Message RAM.....	970
38.8.	Register Summary.....	979
39.	Parallel Capture Controller (PCC).....	1048
39.1.	Overview.....	1048
39.2.	Features.....	1048
39.3.	Block Diagram.....	1048

39.4.	Signal Description.....	1048
39.5.	Peripheral Dependencies.....	1048
39.6.	Functional Description.....	1049
39.7.	Register Summary.....	1056
40.	Universal Serial Bus (USB).....	1066
40.1.	Overview.....	1066
40.2.	Features.....	1066
40.3.	USB Block Diagram.....	1067
40.4.	Signal Description.....	1067
40.5.	Peripheral Dependencies.....	1067
40.6.	Functional Description.....	1069
40.7.	Common Device / Host Register Summary.....	1088
40.8.	General Device Register Summary.....	1095
40.9.	Device Endpoint n Register Summary.....	1108
40.10.	Endpoint Descriptors Structure.....	1118
40.11.	Device Endpoint n Descriptor Bank 0/1 .....	1119
40.12.	General Host Register Summary .....	1125
40.13.	Host Pipe n Register Summary.....	1139
40.14.	Pipe Descriptors Structure.....	1151
40.15.	Host Pipe n Descriptor Bank 0 / 1.....	1152
41.	Ethernet MAC (GMAC).....	1160
41.1.	Description.....	1160
41.2.	Features.....	1160
41.3.	Block Diagram.....	1161
41.4.	Signal Description.....	1161
41.5.	Peripheral Dependencies.....	1162
41.6.	Functional Description.....	1162
41.7.	Programming Interface.....	1186
41.8.	Register Summary.....	1190
42.	Position Decoder (PDEC).....	1312
42.1.	Overview.....	1312
42.2.	Features.....	1312
42.3.	Block Diagram.....	1313
42.4.	Signal Description.....	1313
42.5.	Peripheral Dependencies.....	1313
42.6.	Functional Description.....	1315
42.7.	Register Summary.....	1327
43.	Configurable Custom Logic (CCL).....	1352
43.1.	Overview.....	1352
43.2.	Features.....	1352
43.3.	Block Diagram.....	1353
43.4.	Signal Description.....	1353
43.5.	Peripheral Dependencies.....	1353
43.6.	Functional Description.....	1354
43.7.	Register Summary.....	1364

44. Timer/Counter (TC).....	1369
44.1. Overview.....	1369
44.2. Features.....	1369
44.3. Block Diagram.....	1370
44.4. Signal Description.....	1370
44.5. Peripheral Dependencies.....	1371
44.6. Functional Description.....	1373
44.7. Register Summary - 8-bit Mode.....	1390
44.8. Register Summary - 16-bit Mode.....	1412
44.9. Register Summary - 32-bit Mode.....	1432
45. Timer/Counter for Control Applications (TCC).....	1452
45.1. Overview.....	1452
45.2. Features.....	1452
45.3. Block Diagram.....	1453
45.4. Signal Description.....	1454
45.5. Peripheral Dependencies.....	1454
45.6. Functional Description.....	1456
45.7. Register Summary.....	1489
46. Advanced Encryption Standard (AES).....	1532
46.1. Overview.....	1532
46.2. Features.....	1532
46.3. Block Diagram.....	1533
46.4. Peripheral Dependencies.....	1533
46.5. Functional Description.....	1534
46.6. Register Summary.....	1543
47. Public Key Cryptography Controller (PUKCC).....	1560
47.1. Overview.....	1560
47.2. Features.....	1560
47.3. Peripheral Dependencies.....	1560
47.4. Functional Description.....	1561
48. True Random Number Generator (TRNG).....	1562
48.1. Overview.....	1562
48.2. Features.....	1562
48.3. Block Diagram.....	1562
48.4. Peripheral Dependencies.....	1562
48.5. Functional Description.....	1563
48.6. Register Summary.....	1565
49. Integrity Check Monitor (ICM).....	1572
49.1. Overview.....	1572
49.2. Features.....	1572
49.3. Block Diagram.....	1573
49.4. Peripheral Dependencies.....	1573
49.5. Functional Description.....	1574
49.6. Register Summary - ICM.....	1587

50. Hardware Security Module (HSM).....	1606
50.1. Overview.....	1606
50.2. Features.....	1606
50.3. Applications .....	1606
50.4. Signal Description.....	1607
50.5. Peripheral Dependencies.....	1607
50.6. Functional Description.....	1607
51. Analog-to-Digital Converter (ADC).....	1608
51.1. Overview.....	1608
51.2. Features.....	1608
51.3. Block Diagram.....	1609
51.4. Signal Description.....	1609
51.5. Peripheral Dependencies.....	1609
51.6. Functional Description.....	1611
51.7. Register Summary.....	1626
52. Analog Comparators (AC).....	1657
52.1. Overview.....	1657
52.2. Features.....	1657
52.3. Block Diagram.....	1658
52.4. Signal Description.....	1658
52.5. Peripheral Dependencies.....	1658
52.6. Functional Description.....	1660
52.7. Register Summary.....	1669
53. Digital-to-Analog Converter (DAC).....	1686
53.1. Overview.....	1686
53.2. Features.....	1686
53.3. Block Diagram.....	1686
53.4. Signal Description.....	1686
53.5. Peripheral Dependencies.....	1687
53.6. Functional Description.....	1688
53.7. Register Summary.....	1695
54. Peripheral Touch Controller (PTC).....	1712
54.1. Overview.....	1712
54.2. Features.....	1712
54.3. Block Diagram.....	1713
54.4. Signal Description.....	1714
54.5. System Dependencies.....	1714
54.6. Functional Description.....	1716
55. Electrical Specifications 85°C.....	1717
55.1. Disclaimer.....	1717
55.2. Absolute Maximum Ratings.....	1717
55.3. General Operating Ratings and Thermal Conditions.....	1718
55.4. Power Supply.....	1719
55.5. MCU Active Current Consumption.....	1722
55.6. MCU Idle Current Consumption.....	1723

55.7.	MCU Standby Current Consumption.....	1725
55.8.	MCU Hibernate Current Consumption.....	1729
55.9.	MCU Backup Current Consumption.....	1731
55.10.	MCU Off Current Consumption.....	1733
55.11.	Wake-Up Timings Electrical Specifications.....	1734
55.12.	Peripheral Active Current.....	1735
55.13.	I/O Pin Electrical Specifications.....	1737
55.14.	Internal Voltage Reference Electrical Specifications.....	1739
55.15.	Maximum Clock Frequencies Electrical Specifications.....	1740
55.16.	XOSC Maximum Clock Frequencies Electrical Specifications.....	1741
55.17.	XOSC32K Electrical Specifications.....	1744
55.18.	OSCULP32K Electrical Specifications.....	1746
55.19.	DFLL48M Electrical Specifications .....	1747
55.20.	FDPLL200M Electrical Specifications.....	1748
55.21.	DAC Module Electrical Specifications.....	1749
55.22.	ADC Electrical Specifications.....	1752
55.23.	AC Electrical Specifications.....	1760
55.24.	PTC Electrical Specifications.....	1762
55.25.	SPI Electrical Specifications.....	1763
55.26.	USART Electrical Specifications.....	1767
55.27.	I <sup>2</sup> S Electrical Specifications.....	1768
55.28.	I <sup>2</sup> C Electrical Specifications.....	1772
55.29.	QSPI Electrical Specifications.....	1778
55.30.	CAN Electrical Specifications.....	1780
55.31.	TC Electrical Specifications.....	1782
55.32.	TCC Electrical Specifications.....	1784
55.33.	USB Electrical Specifications.....	1786
55.34.	PCC Electrical Specifications.....	1787
55.35.	NVM Block (Flash, Data Flash, NVM Configuration Rows) Electrical Specifications.....	1788
55.36.	EEPROM Electrical Specifications.....	1789
55.37.	GMAC Electrical Specifications.....	1791
55.38.	FREQM Electrical Specifications.....	1794
55.39.	TRNG Electrical Specifications.....	1795
55.40.	PDEC Electrical Specifications.....	1796
55.41.	SDHC Electrical Specifications.....	1798
55.42.	SWD 2-Wire Electrical Specifications.....	1800
56.	Electrical Specifications 125°C.....	1801
56.1.	Disclaimer.....	1801
56.2.	General Operating Ratings and Thermal Conditions.....	1801
56.3.	Power Supply.....	1802
56.4.	MCU Active Current Consumption.....	1802
56.5.	MCU Idle Current Consumption.....	1804
56.6.	MCU Standby Current Consumption.....	1806
56.7.	MCU Hibernate Current Consumption.....	1809
56.8.	MCU Backup Current Consumption.....	1811
56.9.	MCU Off Current Consumption.....	1813
56.10.	Peripheral Active Current.....	1813
56.11.	I/O Pin Electrical Specifications.....	1815

56.12. Maximum Clock Frequencies Electrical Specifications.....	1816
56.13. OSCULP32K Electrical Specifications.....	1817
56.14. DFLL48M Electrical Specifications .....	1818
56.15. FDPLL200M Electrical Specifications.....	1819
56.16. DAC Module Electrical Specifications.....	1820
56.17. ADC Electrical Specifications.....	1821
56.18. AC Electrical Specifications.....	1825
56.19. SPI Electrical Specifications.....	1827
56.20. USART Electrical Specifications.....	1831
56.21. I <sup>2</sup> S Electrical Specifications.....	1832
56.22. QSPI Electrical Specifications.....	1834
56.23. CAN Electrical Specifications.....	1836
56.24. TC Electrical Specifications.....	1837
56.25. TCC Electrical Specifications.....	1838
56.26. PCC Electrical Specifications.....	1840
56.27. NVM Block (Flash, Data Flash, NVM Configuration Rows) Electrical Specifications.....	1840
56.28. EEPROM Electrical Specifications.....	1841
56.29. FREQM Electrical Specifications.....	1842
56.30. PDEC Electrical Specifications.....	1843
57. Packaging Information.....	1845
57.1. Package Marking Information.....	1845
57.2. Package Drawings.....	1847
57.3. Soldering Profile.....	1865
58. Schematic Checklist.....	1866
58.1. Introduction.....	1866
58.2. Power Supply.....	1867
58.3. External Analog Reference Connections.....	1871
58.4. External Reset Circuit.....	1874
58.5. Unused or Unconnected Pins.....	1874
58.6. Clocks and Crystal Oscillators.....	1875
58.7. Programming and Debugging.....	1877
58.8. Designing for High-Speed Peripherals.....	1878
58.9. QSPI Interface.....	1880
58.10. USB Interface.....	1880
59. Conventions.....	1881
59.1. Numerical Notation.....	1881
59.2. Memory Size and Type.....	1881
59.3. Frequency and Time.....	1881
59.4. Registers and Bits.....	1881
60. Acronyms and Abbreviations.....	1883
61. PIC32CX SG41/SG60/SG61 Revision History.....	1885
Microchip Information.....	1894
The Microchip Website.....	1894
Product Change Notification Service.....	1894
Customer Support.....	1894

Product Identification System.....	1895
Microchip Devices Code Protection Feature.....	1895
Legal Notice.....	1895
Trademarks.....	1896
Quality Management System.....	1896
Worldwide Sales and Service.....	1897

# 1. Configuration Summary

Table 1-1. PIC32CX SG41/SG60/SG61 Family Features

Device	Flash (KB)	SRAM (KB) / Backup SRAM (KB)	Pins	Packages	I/O Pins <sup>(1)</sup>	Peripherals														Analog			Safety and Security												
						Ethernet Controller	CAN-FD	SERCOM <sup>(2,3)</sup>	TC / Compare-Capture	TCC (24-bit/16-bit)	I <sup>2</sup> S	FS USB	QSPI	SDHC	DMA Channels	Parallel Capture Controller (data size)	Position Decoder	RTC / WDT	Event System (Channels)	External Interrupt Lines	ADC (Channels ADC0/ADC1)	Analog Comparators (Channels)	DAC (Channels)	Peripheral Touch Controller	AES	TRNG	Public Key Cryptography (PUKCC)	Integrity Check Monitor	Tamper Pins	Hardware Security Module	Immutable Boot	Boot Read Protection			
PIC32CX1025SG41064	1024	256/8	64	TQFP	51			6	6/2							1	10													3	N	Y	Y		
PIC32CX1025SG41100			100	TQFP	81																											N	Y	Y	
PIC32CX1025SG41128			128		99																														
PIC32CX1025SG60100			100	TQFP / TFBGA	81	Y	Y	8	8/2	2/3	Y	Y	Y		2	32	14	Y	Y / Y	32	16		4	2	Y	Y	Y	Y	Y	5		N	N		
PIC32CX1025SG60128			128	TQFP	94																													Y	
PIC32CX1025SG61100			100	TQFP / TFBGA	81																													Y	Y
PIC32CX1025SG61128			128	TQFP	94																														

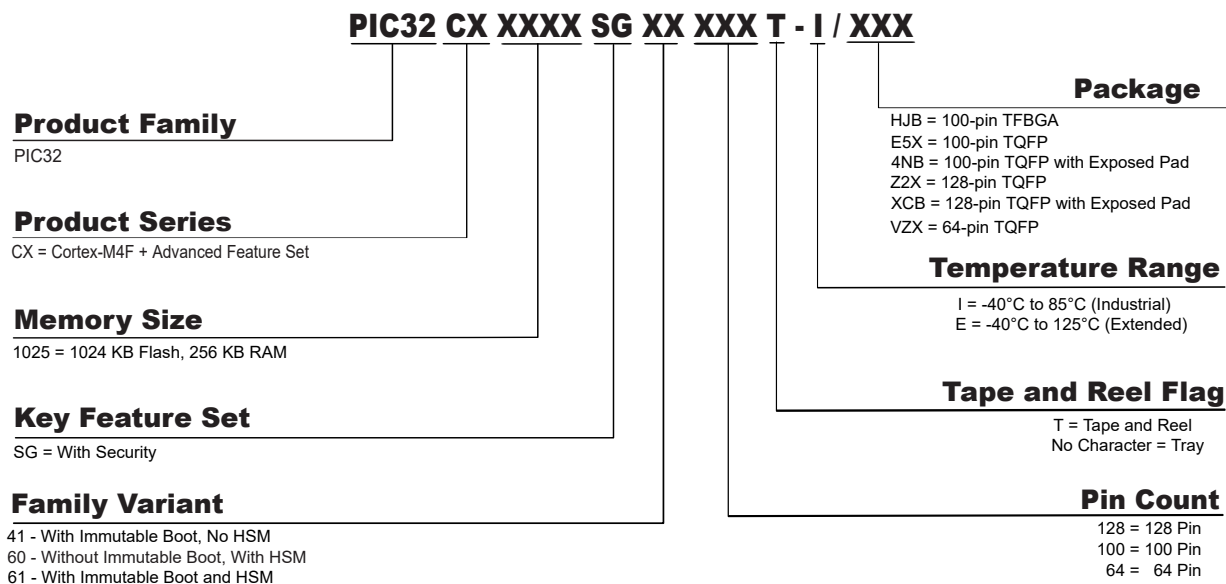
### Notes:

- Five I/Os (PB26, PB27, PB28, PB29 and PC04) are not connected as reserved for the HSM interconnection (PIC32CX SG60/SG61 only).
- SERCOM2 is assigned to the HSM interconnection (PIC32CX SG60/SG61 only).
- I<sup>2</sup>C is not supported on all SERCOM pins. Refer to the Chapter "SERCOM I<sup>2</sup>C Configuration " for a list of supported features for each peripheral instance.



## 2. Ordering Information

Figure 2-1. Composition of the Ordering Numbers<sup>(1,2,3)</sup>



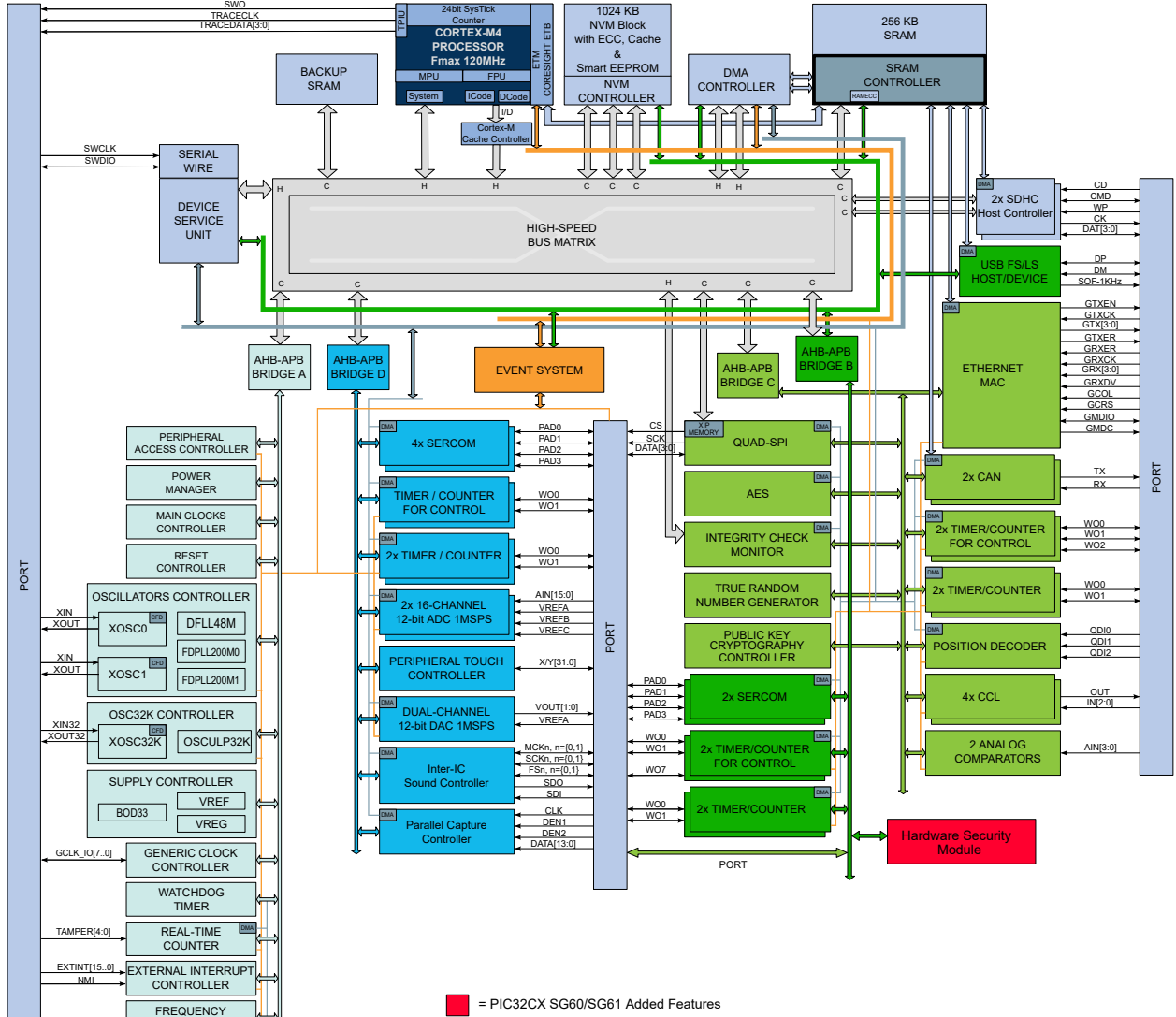
### Notes:

1. Not all combinations are valid. The available device part numbers are listed in [Configuration Summary](#).
2. HJB, 4NB, and XCB are package styles reserved to PIC32CX SG60/SG61. E5X and Z2X are package styles reserved to PIC32CX SG41.
3. PIC32CX SG60/SG61 parts shown are intended for prototyping purposes only and will have maximum limit restriction. For production volume orders, a customized part number is required to ensure security. Please contact Microchip local sales office.

### 3. Block Diagram

The following figure illustrates the PIC32CX SG41/SG60/SG61 block diagram.

Figure 3-1. PIC32CX SG41/SG60/SG61 Block Diagram



**Notes:**

1. Number of peripheral instances, channels, input/output pins can differ between the different packages.
2. SERCOM2 is assigned to the HSM interconnection (PIC32CX SG60/SG61 only).

## 4. Pinout and Packaging

Each pin is controlled by the I/O Pin Controller (PORT) as a general purpose I/O and alternatively can be assigned to one of the peripheral functions: A, B, C, D, E, F, G, H, I, J, K, L, M, or N.

The following tables describe the peripheral signals multiplexed to the PORT I/O pins for each package.



I/Os for SERCOM, GMAC, I<sup>2</sup>S, TC, TCC and PDEC peripherals are grouped into I/O sets, listed in the [IOSET Configurations](#) Chapter. For these peripherals, it is mandatory to use I/Os that belong to the same I/O set. The peripheral's timings are not guaranteed when I/Os from different I/O sets are mixed.



Any and all I/O as well as digital alternate functions on AVDD analog cluster must be confined as inputs only. Refer to the I/O PINMUX tables for the list per package of pins powered by AVDD.

**Note:** The IOSET configurations for the concerned digital alternate output functions must also be considered.

The column "Reset State" indicates the reset state of the line with mnemonics:

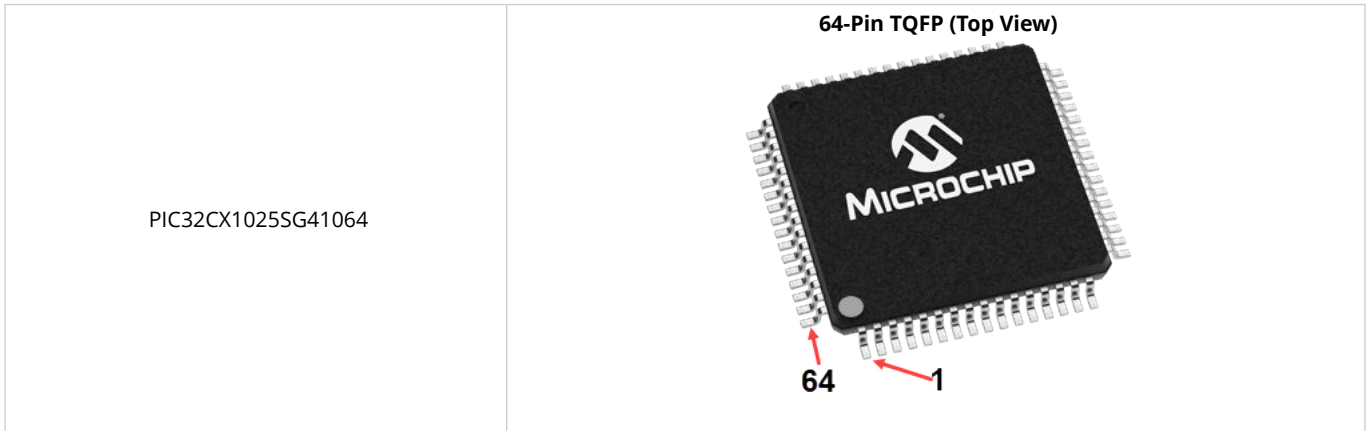
- "I/O" or "Peripheral Function" indicates whether the I/O pin resets in I/O mode or in peripheral function mode.
- "I"/"O"/"Hi-Z" indicates whether the I/O is configured as an input, output, or is tri-stated.
- "PU"/"PD" indicates whether pull up, pull down, or nothing is enabled.

**Note:** The schematic checklist chapter provides the user with the requirements regarding the different pin connections that must be considered before starting any new board design and information on the minimum hardware resources required to develop an application.



**Important:** Not all signals are available on all devices. Refer to the Configuration Summary for available peripherals.

## 4.1 64-pin TQFP



**Table 4-1. 64-pin TQFP I/O PINMUX**

64-pin TQFP	Port Group:	A	B (1)						C (3)	D (3)	E	F (2)	G	H	I	J	K	L	M	N	Power Rail	Reset State
	Pad Name	EIC	ANAREF	ADC0	ADC1	AC	DAC	PTC	SERCOM	SERCOM	TC	TCC	TCC, PDEC	CAN1, QSPI, USB, CORTEX_CM4	CAN0, SDHC	I2S	PCC	GMAC	GCLK, AC	CCL		
1	PA00	EXTINT[0]	-	-	-	-	-	-	SERCOM1 / PAD[0]	TC2 / WO[0]	-	-	-	-	-	-	-	-	-	-	VSWOUT	I/O, Hi-Z
2	PA01	EXTINT[1]	-	-	-	-	-	-	SERCOM1 / PAD[1]	TC2 / WO[1]	-	-	-	-	-	-	-	-	-	-	VSWOUT	I/O, Hi-Z
3	PA02	EXTINT[2]	-	AIN[0]	-	-	VOUT[0]	-	-	-	-	-	-	-	-	-	-	-	-	-	AVDD	I/O, Hi-Z
4	PA03	EXTINT[3]	VREFA	AIN[1]	-	-	-	X0 / Y0	-	-	-	-	-	-	-	-	-	-	-	-	AVDD	I/O, Hi-Z
5	PB04	EXTINT[4]	-	-	AIN[6]	-	-	X22 / Y22	-	-	-	-	-	-	-	-	-	-	-	-	AVDD	I/O, Hi-Z
6	PB05	EXTINT[5]	-	-	AIN[7]	-	-	X23 / Y23	-	-	-	-	-	-	-	-	-	-	-	-	AVDD	I/O, Hi-Z
7	AVSS	-	-	-	-	-	-	-	-	-	-	-	-	-	-	-	-	-	-	-	-	-
8	AVDD	-	-	-	-	-	-	-	-	-	-	-	-	-	-	-	-	-	-	-	-	-
9	PB06	EXTINT[6]	-	-	AIN[8]	-	-	X24 / Y24	-	-	-	-	-	-	-	-	-	-	-	IN[6]	AVDD	I/O, Hi-Z
10	PB07	EXTINT[7]	-	-	AIN[9]	-	-	X25 / Y25	-	-	-	-	-	-	-	-	-	-	-	IN[7]	AVDD	I/O, Hi-Z
11	PB08	EXTINT[8]	-	AIN[2]	AIN[0]	-	-	X1 / Y1	-	SERCOM4 / PAD[0]	TC4 / WO[0]	-	-	-	-	-	-	-	-	IN[8]	AVDD	I/O, Hi-Z
12	PB09	EXTINT[9]	-	AIN[3]	AIN[1]	-	-	X2 / Y2	-	SERCOM4 / PAD[1]	TC4 / WO[1]	-	-	-	-	-	-	-	-	OUT[2]	AVDD	I/O, Hi-Z
13	PA04	EXTINT[4]	VREFB	AIN[4]	-	AIN[0]	-	X3 / Y3	-	SERCOM0 / PAD[0]	TC0 / WO[0]	-	-	-	-	-	-	-	-	IN[0]	AVDD	I/O, Hi-Z
14	PA05	EXTINT[5]	-	AIN[5]	-	AIN[1]	VOUT[1]	-	-	SERCOM0 / PAD[1]	TC0 / WO[1]	-	-	-	-	-	-	-	-	IN[1]	AVDD	I/O, Hi-Z
15	PA06	EXTINT[6]	VREFC	AIN[6]	-	AIN[2]	-	X4 / Y4	-	SERCOM0 / PAD[2]	TC1 / WO[0]	-	-	-	SDHC0 / SDCD	-	-	-	-	IN[2]	AVDD	I/O, Hi-Z
16	PA07	EXTINT[7]	-	AIN[7]	-	AIN[3]	-	X5 / Y5	-	SERCOM0 / PAD[3]	TC1 / WO[1]	-	-	-	SDHC0 / SDWP	-	-	-	-	OUT[0]	AVDD	I/O, Hi-Z
17	PA08 (4)	NMI	-	AIN[8]	AIN[2]	-	-	X6 / Y6	SERCOM0 / PAD[0]	SERCOM2 / PAD[1]	TC0 / WO[0]	TCC0 / WO[0]	TCC1 / WO[4]	QSPI / DATA[0]	SDHC0 / SDCMD	MCK[0]	-	-	-	IN[3]	VDD	I/O, Hi-Z
18	PA09 (4)	EXTINT[9]	-	AIN[9]	AIN[3]	-	-	X7 / Y7	SERCOM0 / PAD[1]	SERCOM2 / PAD[0]	TC0 / WO[1]	TCC0 / WO[1]	TCC1 / WO[5]	QSPI / DATA[1]	SDHC0 / SDDAT[0]	FS[0]	-	-	-	IN[4]	VDD	I/O, Hi-Z

.....continued

64-pin TQFP	Port Group:	A	B (1)						C (3)	D (3)	E	F (2)	G	H	I	J	K	L	M	N	Power Rail	Reset State
	Pad Name	EIC	ANAREF	ADC0	ADC1	AC	DAC	PTC	SERCOM	SERCOM	TC	TCC	TCC, PDEC	CAN1, QSPI, USB, CORTEX_CM4	CAN0, SDHC	IPS	PCC	GMAC	GCLK, AC	CCL		
19	PA10	EXTINT[10]	-	AIN[10]	-	-	-	X8 / Y8	SERCOM0 / PAD[2]	SERCOM2 / PAD[2]	TC1 / WO[0]	TCC0 / WO[2]	TCC1 / WO[6]	QSPI / DATA[2]	SDHC0 / SDDAT[1]	SCK[0]	-	-	GCLK / IO[4]	IN[5]	VDD	I/O, Hi-Z
20	PA11	EXTINT[11]	-	AIN[11]	-	-	-	X9 / Y9	SERCOM0 / PAD[3]	SERCOM2 / PAD[3]	TC1 / WO[1]	TCC0 / WO[3]	TCC1 / WO[7]	QSPI / DATA[3]	SDHC0 / SDDAT[2]	SDO	-	-	GCLK / IO[5]	OUT[1]	VDD	I/O, Hi-Z
21	VDD	-	-	-	-	-	-	-	-	-	-	-	-	-	-	-	-	-	-	-	-	-
22	VSS	-	-	-	-	-	-	-	-	-	-	-	-	-	-	-	-	-	-	-	-	-
23	PB10	EXTINT[10]	-	-	-	-	-	-	SERCOM4 / PAD[2]	TC5 / WO[0]	TCC0 / WO[4]	TCC1 / WO[0]	QSPI / SCK	SDHC0 / SDDAT[3]	SDI	-	-	GCLK / IO[4]	IN[11]	VDD	I/O, Hi-Z	
24	PB11	EXTINT[11]	-	-	-	-	-	-	SERCOM4 / PAD[3]	TC5 / WO[1]	TCC0 / WO[5]	TCC1 / WO[1]	QSPI / CS	SDHC0 / SDCK	FS[1]	-	-	GCLK / IO[5]	OUT[1]	VDD	I/O, Hi-Z	
25	PB12	EXTINT[12]	-	-	-	-	-	X26 / Y26	SERCOM4 / PAD[0]	-	TC4 / WO[0]	TCC3 / WO[0]	TCC0 / WO[0]	CAN1 / TX	SDHC0 / SDCK	SCK[1]	-	-	GCLK / IO[6]	-	VDD	I/O, Hi-Z
26	PB13	EXTINT[13]	-	-	-	-	-	X27 / Y27	SERCOM4 / PAD[1]	-	TC4 / WO[1]	TCC3 / WO[1]	TCC0 / WO[1]	CAN1 / RX	SDHC0 / SDWP	MCK[1]	-	-	GCLK / IO[7]	-	VDD	I/O, Hi-Z
27	PB14	EXTINT[14]	-	-	-	-	-	X28 / Y28	SERCOM4 / PAD[2]	-	TC5 / WO[0]	TCC4 / WO[0]	TCC0 / WO[2]	CAN1 / TX	-	-	DATA[8]	GMDC	GCLK / IO[0]	IN[9]	VDD	I/O, Hi-Z
28	PB15	EXTINT[15]	-	-	-	-	-	X29 / Y29	SERCOM4 / PAD[3]	-	TC5 / WO[1]	TCC4 / WO[1]	TCC0 / WO[3]	CAN1 / RX	-	-	DATA[9]	GMDIO	GCLK / IO[1]	IN[10]	VDD	I/O, Hi-Z
29	PA12 (4)	EXTINT[12]	-	-	-	-	-	-	SERCOM2 / PAD[0]	SERCOM4 / PAD[1]	TC2 / WO[0]	TCC0 / WO[6]	TCC1 / WO[2]	-	SDHC0 / SDCK	-	DEN1	GRX[1]	AC / CMP[0]	-	VDD	I/O, Hi-Z
30	PA13 (4)	EXTINT[13]	-	-	-	-	-	-	SERCOM2 / PAD[1]	SERCOM4 / PAD[0]	TC2 / WO[1]	TCC0 / WO[7]	TCC1 / WO[3]	-	SDHC0 / SDWP	-	DEN2	GRX[0]	AC / CMP[1]	-	VDD	I/O, Hi-Z
31	PA14	EXTINT[14]	-	-	-	-	-	-	SERCOM2 / PAD[2]	SERCOM4 / PAD[2]	TC3 / WO[0]	TCC2 / WO[0]	TCC1 / WO[2]	-	-	-	CLK	GTACK	GCLK / IO[0]	-	VDD	I/O, Hi-Z
32	PA15	EXTINT[15]	-	-	-	-	-	-	SERCOM2 / PAD[3]	SERCOM4 / PAD[3]	TC3 / WO[1]	TCC2 / WO[1]	TCC1 / WO[3]	-	-	-	-	GRXER	GCLK / IO[1]	-	VDD	I/O, Hi-Z
33	VSS	-	-	-	-	-	-	-	-	-	-	-	-	-	-	-	-	-	-	-	-	-
34	VDD	-	-	-	-	-	-	-	-	-	-	-	-	-	-	-	-	-	-	-	-	-
35	PA16 (4)	EXTINT[0]	-	-	-	-	-	X10 / Y10	SERCOM1 / PAD[0]	SERCOM3 / PAD[1]	TC2 / WO[0]	TCC1 / WO[0]	TCC0 / WO[4]	-	-	-	DATA[0]	GCRS	GCLK / IO[2]	IN[0]	VDD	I/O, Hi-Z
36	PA17 (4)	EXTINT[1]	-	-	-	-	-	X11 / Y11	SERCOM1 / PAD[1]	SERCOM3 / PAD[0]	TC2 / WO[1]	TCC1 / WO[1]	TCC0 / WO[5]	-	-	-	DATA[1]	GTEN	GCLK / IO[3]	IN[1]	VDD	I/O, Hi-Z

.....continued																							
64-pin TQFP	Port Group:	A	B (1)					C (3)		D (3)	E	F (2)	G	H	I	J	K	L	M	N	Power Rail	Reset State	
	Pad Name	EIC	ANAREF	ADCO	ADC1	AC	DAC	PTC	SERCOM	SERCOM	TC	TCC	TCC, PDEC	CAN1, QSPI, USB, CORTEX_CM4	CAN0, SDHC	IPS	PCC	GMAC	GCLK, AC	CCL			
37	PA18	EXTINT[2]	-	-	-	-	-	X12 / Y12	SERCOM1 / PAD[2]	SERCOM3 / PAD[2]	TC3 / WO[0]	TCC1 / WO[2]	TCC0 / WO[6]	-	-	-	DATA[2]	GTX[0]	AC / CMP[0]	IN[2]	VDD	I/O, Hi-Z	
38	PA19	EXTINT[3]	-	-	-	-	-	X13 / Y13	SERCOM1 / PAD[3]	SERCOM3 / PAD[3]	TC3 / WO[1]	TCC1 / WO[3]	TCC0 / WO[7]	-	-	-	DATA[3]	GTX[1]	AC / CMP[1]	OUT[0]	VDD	I/O, Hi-Z	
39	PB16	EXTINT[0]	-	-	-	-	-	-	SERCOM5 / PAD[0]	-	TC6 / WO[0]	TCC3 / WO[0]	TCC0 / WO[4]	-	SDHC1 / SDCD	SCK[0]	-	-	GCLK / IO[2]	IN[11]	VDD	I/O, Hi-Z	
40	PB17	EXTINT[1]	-	-	-	-	-	-	SERCOM5 / PAD[1]	-	TC6 / WO[1]	TCC3 / WO[1]	TCC0 / WO[5]	-	SDHC1 / SDWP	MCK[0]	-	-	GCLK / IO[3]	OUT[3]	VDD	I/O, Hi-Z	
41	PA20	EXTINT[4]	-	-	-	-	-	X14 / Y14	SERCOM5 / PAD[2]	SERCOM3 / PAD[2]	TC7 / WO[0]	TCC1 / WO[4]	TCC0 / WO[0]	-	SDHC1 / SDCMD	FS[0]	DATA[4]	GMDC	-	-	VDD	I/O, Hi-Z	
42	PA21	EXTINT[5]	-	-	-	-	-	X15 / Y15	SERCOM5 / PAD[3]	SERCOM3 / PAD[3]	TC7 / WO[1]	TCC1 / WO[5]	TCC0 / WO[1]	-	SDHC1 / SDCK	SDO	DATA[5]	GMDIO	-	-	VDD	I/O, Hi-Z	
43	PA22 (4)	EXTINT[6]	-	-	-	-	-	X16 / Y16	SERCOM3 / PAD[0]	SERCOM5 / PAD[1]	TC4 / WO[0]	TCC1 / WO[6]	TCC0 / WO[2]	-	CAN0 / TX	SDI	DATA[6]	-	-	IN[6]	VDD	I/O, Hi-Z	
44	PA23 (4)	EXTINT[7]	-	-	-	-	-	X17 / Y17	SERCOM3 / PAD[1]	SERCOM5 / PAD[0]	TC4 / WO[1]	TCC1 / WO[7]	TCC0 / WO[3]	USB / SOF_1KHZ	CAN0 / RX	FS[1]	DATA[7]	-	-	IN[7]	VDD	I/O, Hi-Z	
45	PA24	EXTINT[8]	-	-	-	-	-	-	SERCOM3 / PAD[2]	SERCOM5 / PAD[2]	TC5 / WO[0]	TCC2 / WO[2]	PDEC / QDI[0]	USB / DM	CAN0 / TX	-	-	-	-	IN[8]	VDD	I, PD	
46	PA25	EXTINT[9]	-	-	-	-	-	-	SERCOM3 / PAD[3]	SERCOM5 / PAD[3]	TC5 / WO[1]	-	PDEC / QDI[1]	USB / DP	CAN0 / RX	-	-	-	-	OUT[2]	VDD	I, PD	
47	VSS	-	-	-	-	-	-	-	-	-	-	-	-	-	-	-	-	-	-	-	-	-	
48	VDD	-	-	-	-	-	-	-	-	-	-	-	-	-	-	-	-	-	-	-	-	-	
49	PB22	EXTINT[6]	-	-	-	-	-	-	SERCOM1 / PAD[2]	SERCOM5 / PAD[2]	TC7 / WO[0]	-	PDEC / QDI[2]	USB / SOF_1KHZ	-	-	-	-	-	GCLK / IO[0]	IN[0]	VDD	I/O, Hi-Z
50	PB23	EXTINT[7]	-	-	-	-	-	-	SERCOM1 / PAD[3]	SERCOM5 / PAD[3]	TC7 / WO[1]	-	PDEC / QDI[0]	-	-	-	-	-	-	GCLK / IO[1]	OUT[0]	VDD	I/O, Hi-Z
51	PA27	EXTINT[11]	-	-	-	-	-	X18 / Y18	-	-	-	-	-	-	-	-	-	-	-	GCLK / IO[1]	-	VDD	I/O, Hi-Z
52	RESET	-	-	-	-	-	-	-	-	-	-	-	-	-	-	-	-	-	-	-	VDD	-	
53	VDDCORE	-	-	-	-	-	-	-	-	-	-	-	-	-	-	-	-	-	-	-	-	-	
54	VSS	-	-	-	-	-	-	-	-	-	-	-	-	-	-	-	-	-	-	-	-	-	
55	VSW	-	-	-	-	-	-	-	-	-	-	-	-	-	-	-	-	-	-	-	-	-	

.....continued

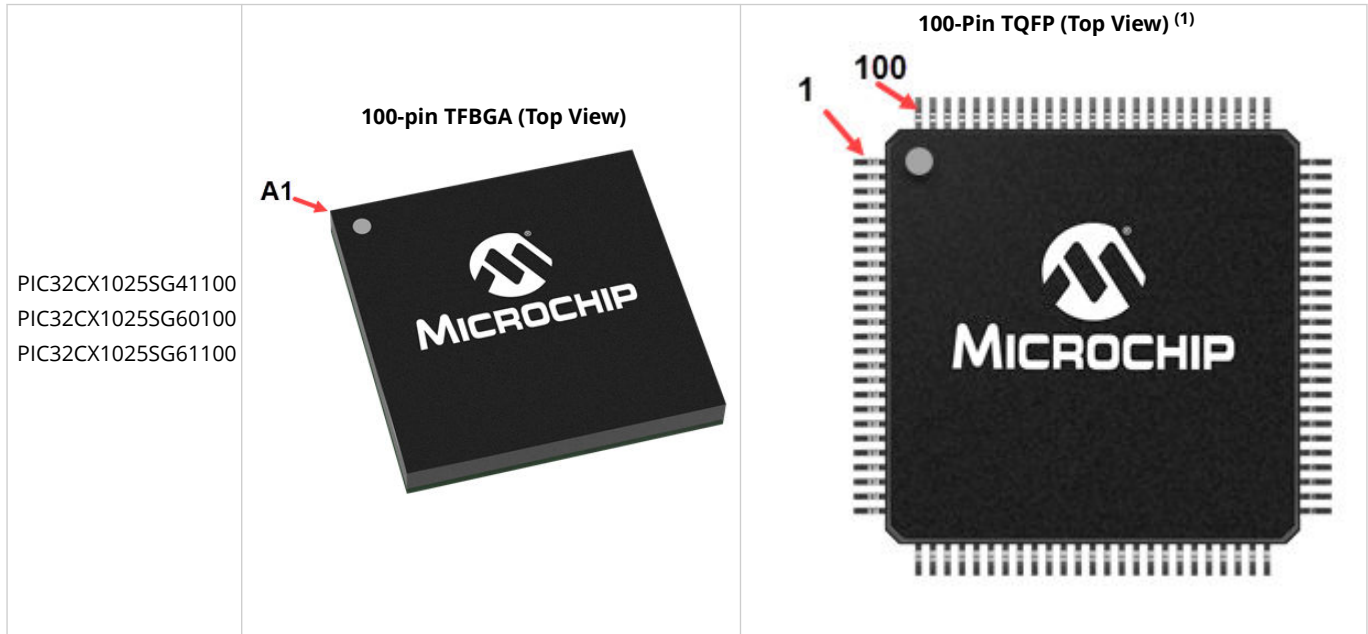
64-pin TQFP	Port Group:	A	B (1)						C (3)	D (3)	E	F (2)	G	H	I	J	K	L	M	N	Power Rail	Reset State
	Pad Name	EIC	ANAREF	ADCO	ADC1	AC	DAC	PTC	SERCOM	SERCOM	TC	TCC	TCC, PDEC	CAN1, QSPI, USB, CORTEX_CM4	CAN0, SDHC	I2S	PCC	GMAC	GCLK, AC	CCL		
56	VDD	-	-	-	-	-	-	-	-	-	-	-	-	-	-	-	-	-	-	-	-	-
57	PA30	EXTINT[14]	-	-	-	-	-	X19 / Y19	SERCOM7 / PAD[2]	SERCOM1 / PAD[2]	TC6 / WO[0]	TCC2 / WO[0]	-	CORTEX_CM4 / SWCLK	-	-	-	-	GCLK / IO[0]	IN[3]	VDD	I, PU
58	PA31	EXTINT[15]	-	-	-	-	-	-	SERCOM7 / PAD[3]	SERCOM1 / PAD[3]	TC6 / WO[1]	TCC2 / WO[1]	-	CORTEX_CM4 / SWDIO	-	-	-	-	-	OUT[1]	VDD	I/O, Hi-Z
59	PB30	EXTINT[14]	-	-	-	-	-	-	SERCOM7 / PAD[0]	SERCOM5 / PAD[1]	TC0 / WO[0]	TCC4 / WO[0]	TCC0 / WO[6]	CORTEX_CM4 / SWO	-	-	-	-	-	-	VDD	I/O, Hi-Z
60	PB31	EXTINT[15]	-	-	-	-	-	-	SERCOM7 / PAD[1]	SERCOM5 / PAD[0]	TC0 / WO[1]	TCC4 / WO[1]	TCC0 / WO[7]	-	-	-	-	-	-	-	VDD	I/O, Hi-Z
61	PB00	EXTINT[0]	-	AIN[12]	-	-	-	X30 / Y30	-	SERCOM5 / PAD[2]	TC7 / WO[0]	-	-	-	-	-	-	-	-	IN[1]	VSWOUT	I/O, Hi-Z
62	PB01	EXTINT[1]	-	AIN[13]	-	-	-	X31 / Y31	-	SERCOM5 / PAD[3]	TC7 / WO[1]	-	-	-	-	-	-	-	-	IN[2]	VSWOUT	I/O, Hi-Z
63	PB02	EXTINT[2]	-	AIN[14]	-	-	-	X20 / Y20	-	SERCOM5 / PAD[0]	TC6 / WO[0]	TCC2 / WO[2]	-	-	-	-	-	-	-	OUT[0]	VSWOUT	I/O, Hi-Z
64	PB03	EXTINT[3]	-	AIN[15]	-	-	-	X21 / Y21	-	SERCOM5 / PAD[1]	TC6 / WO[1]	-	-	-	-	-	-	-	-	-	VSWOUT	I/O, Hi-Z



**Notes:**

1. All analog pin functions are on the peripheral function B. The peripheral function B must be selected to disable the digital control of the pin. The AC has analog signals on the peripheral function B and digital signals on the peripheral function M.
2. Refer to [TCC Configuration Summary](#) table for the list of supported features for each peripheral instance.
3. I<sup>2</sup>C is not supported on all SERCOM pins. Refer to [SERCOM I<sup>2</sup>C Pinout](#) table for the list of supported features for each peripheral instance.
4. The following High-Sink pins have different properties than the regular pins: PA08, PA09, PA12, PA13, PA16, PA17, PA22, and PA23.

## 4.2 100-pin TFBGA and 100-pin TQFP



**Note:**

1. The 4NB (100-pin TQFP) package has an exposed pad.

**Table 4-2. 100-pin TFBGA/100-pin TQFP I/O PINMUX**

	100-pin TQFP	100-pin TFBGA	Port Group:		A	B (2)				C (5)	D (5)	E	F (4)	G	H	I	J	K	L	M	N	Power Rail	Reset State		
			Pad Name	EIC	ANAREF	ADCO	ADC1	AC	DAC	PTC	SERCOM	SERCOM	TC	TCC	TCC, PDEC	CAN1, QSPI, USB, CORTEX_CM4	CAN0, SDHC	I2S	PCC	GMAC	GCLK, AC			CCL	
1	D2	PA00	EXTINT[0]	-	-	-	-	-	-	-	SERCOM1 / PAD[0]	TC2 / WO[0]	-	-	-	-	-	-	-	-	-	-	VSWOUT	I/O, Hi-Z	
2	E2	PA01	EXTINT[1]	-	-	-	-	-	-	-	SERCOM1 / PAD[1]	TC2 / WO[1]	-	-	-	-	-	-	-	-	-	-	VSWOUT	I/O, Hi-Z	
3	C2	PC00	EXTINT[0]	-	-	AIN[10]	-	-	-	-	-	-	-	-	-	-	-	-	-	-	-	-	VSWOUT	I/O, Hi-Z	
4	D3	PC01	EXTINT[1]	-	-	AIN[11]	-	-	-	-	-	-	-	-	-	-	-	-	-	-	-	-	VSWOUT	I/O, Hi-Z	
5	E3	PC02	EXTINT[2]	-	-	AIN[4]	-	-	-	-	-	-	-	-	-	-	-	-	-	-	-	-	AVDD	I/O, Hi-Z	
6	B1	PC03	EXTINT[3]	-	-	AIN[5]	-	-	-	-	-	-	-	-	-	-	-	-	-	-	-	-	AVDD	I/O, Hi-Z	
7	F2	PA02	EXTINT[2]	-	AIN[0]	-	-	VOUT[0]	-	-	-	-	-	-	-	-	-	-	-	-	-	-	AVDD	I/O, Hi-Z	
8	F4	PA03	EXTINT[3]	VREFA	AIN[1]	-	-	-	X0 / Y0	-	-	-	-	-	-	-	-	-	-	-	-	-	AVDD	I/O, Hi-Z	
9	C1	PB04	EXTINT[4]	-	-	AIN[6]	-	-	X22 / Y22	-	-	-	-	-	-	-	-	-	-	-	-	-	AVDD	I/O, Hi-Z	
10	F3	PB05	EXTINT[5]	-	-	AIN[7]	-	-	X23 / Y23	-	-	-	-	-	-	-	-	-	-	-	-	-	AVDD	I/O, Hi-Z	
11	G3	AVSS	-	-	-	-	-	-	-	-	-	-	-	-	-	-	-	-	-	-	-	-	-	-	
12	G4	AVDD	-	-	-	-	-	-	-	-	-	-	-	-	-	-	-	-	-	-	-	-	-	-	
13	G2	PB06	EXTINT[6]	-	-	AIN[8]	-	-	X24 / Y24	-	-	-	-	-	-	-	-	-	-	-	-	-	IN[6]	AVDD	I/O, Hi-Z
14	D1	PB07	EXTINT[7]	-	-	AIN[9]	-	-	X25 / Y25	-	-	-	-	-	-	-	-	-	-	-	-	-	IN[7]	AVDD	I/O, Hi-Z
15	H3	PB08	EXTINT[8]	-	AIN[2]	AIN[0]	-	-	X1 / Y1	-	SERCOM4 / PAD[0]	TC4 / WO[0]	-	-	-	-	-	-	-	-	-	-	IN[8]	AVDD	I/O, Hi-Z
16	E1	PB09	EXTINT[9]	-	AIN[3]	AIN[1]	-	-	X2 / Y2	-	SERCOM4 / PAD[1]	TC4 / WO[1]	-	-	-	-	-	-	-	-	-	-	OUT[2]	AVDD	I/O, Hi-Z
17	F1	PA04	EXTINT[4]	VREFB	AIN[4]	-	AIN[0]	-	X3 / Y3	-	SERCOM0 / PAD[0]	TC0 / WO[0]	-	-	-	-	-	-	-	-	-	-	IN[0]	AVDD	I/O, Hi-Z

.....continued

	100-pin TOFP	100-pin TFBGA	Port Group:		A	B (2)				C (5)	D (5)	E	F (4)	G	H	I	J	K	L	M	N	Power Rail	Reset State	
			Pad Name	EIC		ANAREF	ADCO	ADC1	AC															DAC
18	G1	PA05	EXTINT[5]	-	AIN[5]	-	AIN[1]	VOUT[1]	-	-	SERCOM0 / PAD[1]	TC0 / WO[1]	-	-	-	-	-	-	-	-	-	IN[1]	AVDD	I/O, Hi-Z
19	H2	PA06	EXTINT[6]	VREFC	AIN[6]	-	AIN[2]	-	X4 / Y4	-	SERCOM0 / PAD[2]	TC1 / WO[0]	-	-	-	SDHC0 / SDCD	-	-	-	-	-	IN[2]	AVDD	I/O, Hi-Z
20	H1	PA07	EXTINT[7]	-	AIN[7]	-	AIN[3]	-	X5 / Y5	-	SERCOM0 / PAD[3]	TC1 / WO[1]	-	-	-	SDHC0 / SDWP	-	-	-	-	-	OUT[0]	AVDD	I/O, Hi-Z
21	J1	PC05	EXTINT[5]	-	-	-	-	-	-	SERCOM6 / PAD[1]	-	-	-	-	-	-	-	-	-	-	-	-	VDD	I/O, Hi-Z
22	J2	PC06	EXTINT[6]	-	-	-	-	-	-	SERCOM6 / PAD[2]	-	-	-	-	-	SDHC0 / SDCD	-	-	-	-	-	-	VDD	I/O, Hi-Z
23	K1	PC07	EXTINT[9]	-	-	-	-	-	-	SERCOM6 / PAD[3]	-	-	-	-	-	SDHC0 / SDWP	-	-	-	-	-	-	VDD	I/O, Hi-Z
24	D6	VSS	-	-	-	-	-	-	-	-	-	-	-	-	-	-	-	-	-	-	-	-	-	-
25	D5	VDD	-	-	-	-	-	-	-	-	-	-	-	-	-	-	-	-	-	-	-	-	-	-
26	K3	PA08 (6)	NMI	-	AIN[8]	AIN[2]	-	-	X6 / Y6	SERCOM0 / PAD[0]	SERCOM2 / PAD[1]	TC0 / WO[0]	TCC0 / WO[0]	TCC1 / WO[4]	QSPI / DATA[0]	SDHC0 / SDCMD	MCK[0]	-	-	-	-	IN[3]	VDD	I/O, Hi-Z
27	J3	PA09 (6)	EXTINT[9]	-	AIN[9]	AIN[3]	-	-	X7 / Y7	SERCOM0 / PAD[1]	SERCOM2 / PAD[0]	TC0 / WO[1]	TCC0 / WO[1]	TCC1 / WO[5]	QSPI / DATA[1]	SDHC0 / SDDAT[0]	FS[0]	-	-	-	-	IN[4]	VDD	I/O, Hi-Z
28	K2	PA10	EXTINT[10]	-	AIN[10]	-	-	-	X8 / Y8	SERCOM0 / PAD[2]	SERCOM2 / PAD[2]	TC1 / WO[0]	TCC0 / WO[2]	TCC1 / WO[6]	QSPI / DATA[2]	SDHC0 / SDDAT[1]	SCK[0]	-	-	GCLK / IO[4]	IN[5]	VDD	I/O, Hi-Z	
29	J4	PA11	EXTINT[11]	-	AIN[11]	-	-	-	X9 / Y9	SERCOM0 / PAD[3]	SERCOM2 / PAD[3]	TC1 / WO[1]	TCC0 / WO[3]	TCC1 / WO[7]	QSPI / DATA[3]	SDHC0 / SDDAT[2]	SDO	-	-	GCLK / IO[5]	OUT[1]	VDD	I/O, Hi-Z	
30	E5	VDD	-	-	-	-	-	-	-	-	-	-	-	-	-	-	-	-	-	-	-	-	-	-
31	E4	VSS	-	-	-	-	-	-	-	-	-	-	-	-	-	-	-	-	-	-	-	-	-	-
32	J5	PB10	EXTINT[10]	-	-	-	-	-	-	-	SERCOM4 / PAD[2]	TC5 / WO[0]	TCC0 / WO[4]	TCC1 / WO[0]	QSPI / SCK	SDHC0 / SDDAT[3]	SDI	-	-	GCLK / IO[4]	IN[11]	VDD	I/O, Hi-Z	
33	K4	PB11	EXTINT[11]	-	-	-	-	-	-	-	SERCOM4 / PAD[3]	TC5 / WO[1]	TCC0 / WO[5]	TCC1 / WO[1]	QSPI / CS	SDHC0 / SDCK	FS[1]	-	-	GCLK / IO[5]	OUT[1]	VDD	I/O, Hi-Z	
34	F5	PB12	EXTINT[12]	-	-	-	-	-	X26 / Y26	SERCOM4 / PAD[0]	-	TC4 / WO[0]	TCC3 / WO[0]	TCC0 / WO[0]	CAN1 / TX	SDHC0 / SDCD	SCK[1]	-	-	GCLK / IO[6]	-	VDD	I/O, Hi-Z	
35	G5	PB13	EXTINT[13]	-	-	-	-	-	X27 / Y27	SERCOM4 / PAD[1]	-	TC4 / WO[1]	TCC3 / WO[1]	TCC0 / WO[1]	CAN1 / RX	SDHC0 / SDWP	MCK[1]	-	-	GCLK / IO[7]	-	VDD	I/O, Hi-Z	

.....continued

100-pin TOFP	100-pin TFBGA	Port Group:		A	B (2)					C (5)		D (5)	E	F (4)		G	H	I	J	K	L	M	N	Power Rail	Reset State
		Pad Name	EIC		ANAREF	ADCO	ADC1	AC	DAC	PTC	SERCOM			SERCOM	TC										
36	J6	PB14	EXTINT[14]	-	-	-	-	-	X28 / Y28	SERCOM4 / PAD[2]	-	TC5 / WO[0]	TCC4 / WO[0]	TCC0 / WO[2]	CAN1 / TX	-	-	DATA[8]	GMDC	GCLK / IO[0]	IN[9]	VDD	I/O, Hi-Z		
37	K5	PB15	EXTINT[15]	-	-	-	-	-	X29 / Y29	SERCOM4 / PAD[3]	-	TC5 / WO[1]	TCC4 / WO[1]	TCC0 / WO[3]	CAN1 / RX	-	-	DATA[9]	GMDIO	GCLK / IO[1]	IN[10]	VDD	I/O, Hi-Z		
38	H4	VSS	-	-	-	-	-	-	-	-	-	-	-	-	-	-	-	-	-	-	-	-	-		
39	H5	VDD	-	-	-	-	-	-	-	-	-	-	-	-	-	-	-	-	-	-	-	-	-		
40	K6	PC10	EXTINT[10]	-	-	-	-	-	-	SERCOM6 / PAD[2]	SERCOM7 / PAD[2]	-	TCC0 / WO[0]	TCC1 / WO[4]	-	-	-	-	-	-	-	VDD	I/O, Hi-Z		
41	F6	PC11	EXTINT[11]	-	-	-	-	-	-	SERCOM6 / PAD[3]	SERCOM7 / PAD[3]	-	TCC0 / WO[1]	TCC1 / WO[5]	-	-	-	-	GMDC	-	-	VDD	I/O, Hi-Z		
42	G6	PC12	EXTINT[12]	-	-	-	-	-	-	SERCOM7 / PAD[0]	SERCOM6 / PAD[1]	-	TCC0 / WO[2]	TCC1 / WO[6]	-	-	-	DATA[10]	GMDIO	-	-	VDD	I/O, Hi-Z		
43	H6	PC13	EXTINT[13]	-	-	-	-	-	-	SERCOM7 / PAD[1]	SERCOM6 / PAD[0]	-	TCC0 / WO[3]	TCC1 / WO[7]	-	-	-	DATA[11]	-	-	-	VDD	I/O, Hi-Z		
44	H7	PC14	EXTINT[14]	-	-	-	-	-	-	SERCOM7 / PAD[2]	SERCOM6 / PAD[2]	-	TCC0 / WO[4]	TCC1 / WO[0]	-	-	-	DATA[12]	GRX[3]	-	-	VDD	I/O, Hi-Z		
45	K7	PC15	EXTINT[15]	-	-	-	-	-	-	SERCOM7 / PAD[3]	SERCOM6 / PAD[3]	-	TCC0 / WO[5]	TCC1 / WO[1]	-	-	-	DATA[13]	GRX[2]	-	-	VDD	I/O, Hi-Z		
46	K9	PA12 (6)	EXTINT[12]	-	-	-	-	-	-	SERCOM2 / PAD[0]	SERCOM4 / PAD[1]	TC2 / WO[0]	TCC0 / WO[6]	TCC1 / WO[2]	-	-	SDHC0 / SDCD	-	DEN1	GRX[1]	AC / CMP[0]	-	VDD	I/O, Hi-Z	
47	K8	PA13 (6)	EXTINT[13]	-	-	-	-	-	-	SERCOM2 / PAD[1]	SERCOM4 / PAD[0]	TC2 / WO[1]	TCC0 / WO[7]	TCC1 / WO[3]	-	-	SDHC0 / SDWP	-	DEN2	GRX[0]	AC / CMP[1]	-	VDD	I/O, Hi-Z	
48	J7	PA14	EXTINT[14]	-	-	-	-	-	-	SERCOM2 / PAD[2]	SERCOM4 / PAD[2]	TC3 / WO[0]	TCC2 / WO[0]	TCC1 / WO[2]	-	-	-	CLK	GTXCK	GCLK / IO[0]	-	VDD	I/O, Hi-Z		
49	J8	PA15	EXTINT[15]	-	-	-	-	-	-	SERCOM2 / PAD[3]	SERCOM4 / PAD[3]	TC3 / WO[1]	TCC2 / WO[1]	TCC1 / WO[3]	-	-	-	-	GRXER	GCLK / IO[1]	-	VDD	I/O, Hi-Z		
50	J10	VSS	-	-	-	-	-	-	-	-	-	-	-	-	-	-	-	-	-	-	-	-	-		
51	K10	VDD	-	-	-	-	-	-	-	-	-	-	-	-	-	-	-	-	-	-	-	-	-		
52	J9	PA16 (6)	EXTINT[0]	-	-	-	-	-	X10 / Y10	SERCOM1 / PAD[0]	SERCOM3 / PAD[1]	TC2 / WO[0]	TCC1 / WO[0]	TCC0 / WO[4]	-	-	-	DATA[0]	GCRS	GCLK / IO[2]	IN[0]	VDD	I/O, Hi-Z		
53	H10	PA17 (6)	EXTINT[1]	-	-	-	-	-	X11 / Y11	SERCOM1 / PAD[1]	SERCOM3 / PAD[0]	TC2 / WO[1]	TCC1 / WO[1]	TCC0 / WO[5]	-	-	-	DATA[1]	GTXEN	GCLK / IO[3]	IN[1]	VDD	I/O, Hi-Z		

.....continued

100-pin TOFP	100-pin TFBGA	Port Group:		A	B (2)					C (5)		D (5)	E	F (4)	G	H	I	J	K	L	M	N	Power Rail	Reset State
		Pad Name	EIC	ANAREF	ADCO	ADC1	AC	DAC	PTC	SERCOM	SERCOM	TC	TCC	TCC, PDEC	CAN1, QSPI, USB, CORTEX_CM4	CAN0, SDHC	I2S	PCC	GMAC	GCLK, AC	CCL			
54	G10	PA18	EXTINT[2]	-	-	-	-	-	X12 / Y12	SERCOM1 / PAD[2]	SERCOM3 / PAD[2]	TC3 / WO[0]	TCC1 / WO[2]	TCC0 / WO[6]	-	-	-	DATA[2]	GTX[0]	AC / CMP[0]	IN[2]	VDD	I/O, Hi-Z	
55	E10	PA19	EXTINT[3]	-	-	-	-	-	X13 / Y13	SERCOM1 / PAD[3]	SERCOM3 / PAD[3]	TC3 / WO[1]	TCC1 / WO[3]	TCC0 / WO[7]	-	-	-	DATA[3]	GTX[1]	AC / CMP[1]	OUT[0]	VDD	I/O, Hi-Z	
56	H9	PC16	EXTINT[0]	-	-	-	-	-	-	SERCOM6 / PAD[0]	SERCOM0 / PAD[1]	-	TCC0 / WO[0]	PDEC / QDI[0]	-	-	-	-	GTX[2]	-	-	VDD	I/O, Hi-Z	
57	H8	PC17	EXTINT[1]	-	-	-	-	-	-	SERCOM6 / PAD[1]	SERCOM0 / PAD[0]	-	TCC0 / WO[1]	PDEC / QDI[1]	-	-	-	-	GTX[3]	-	-	VDD	I/O, Hi-Z	
58	G7	PC18	EXTINT[2]	-	-	-	-	-	-	SERCOM6 / PAD[2]	SERCOM0 / PAD[2]	-	TCC0 / WO[2]	PDEC / QDI[2]	-	-	-	-	GRXCK	-	-	VDD	I/O, Hi-Z	
59	G8	PC19	EXTINT[3]	-	-	-	-	-	-	SERCOM6 / PAD[3]	SERCOM0 / PAD[3]	-	TCC0 / WO[3]	-	-	-	-	-	GTXER	-	-	VDD	I/O, Hi-Z	
60	G9	PC20	EXTINT[4]	-	-	-	-	-	-	-	-	-	TCC0 / WO[4]	-	-	-	SDHC1 / SDCD	-	GRXDV	-	IN[9]	VDD	I/O, Hi-Z	
61	E6	PC21	EXTINT[5]	-	-	-	-	-	-	-	-	-	TCC0 / WO[5]	-	-	-	SDHC1 / SDWP	-	GCOL	-	IN[10]	VDD	I/O, Hi-Z	
62	F9	VSS	-	-	-	-	-	-	-	-	-	-	-	-	-	-	-	-	-	-	-	-	-	
63	F10	VDD	-	-	-	-	-	-	-	-	-	-	-	-	-	-	-	-	-	-	-	-	-	
64	E9	PB16	EXTINT[0]	-	-	-	-	-	-	SERCOM5 / PAD[0]	-	TC6 / WO[0]	TCC3 / WO[0]	TCC0 / WO[4]	-	-	SDHC1 / SDCD	SCK[0]	-	-	GCLK / IO[2]	IN[11]	VDD	I/O, Hi-Z
65	D9	PB17	EXTINT[1]	-	-	-	-	-	-	SERCOM5 / PAD[1]	-	TC6 / WO[1]	TCC3 / WO[1]	TCC0 / WO[5]	-	-	SDHC1 / SDWP	MCK[0]	-	-	GCLK / IO[3]	OUT[3]	VDD	I/O, Hi-Z
66	F7	PB18	EXTINT[2]	-	-	-	-	-	-	SERCOM5 / PAD[2]	SERCOM7 / PAD[2]	-	TCC1 / WO[0]	PDEC / QDI[0]	-	-	SDHC1 / SDDAT[0]	-	-	-	GCLK / IO[4]	-	VDD	I/O, Hi-Z
67	E7	PB19	EXTINT[3]	-	-	-	-	-	-	SERCOM5 / PAD[3]	SERCOM7 / PAD[3]	-	TCC1 / WO[1]	PDEC / QDI[1]	-	-	SDHC1 / SDDAT[1]	-	-	-	GCLK / IO[5]	-	VDD	I/O, Hi-Z
68	D8	PB20	EXTINT[4]	-	-	-	-	-	-	SERCOM3 / PAD[0]	SERCOM7 / PAD[1]	-	TCC1 / WO[2]	PDEC / QDI[2]	-	-	SDHC1 / SDDAT[2]	-	-	-	GCLK / IO[6]	-	VDD	I/O, Hi-Z
69	E8	PB21	EXTINT[5]	-	-	-	-	-	-	SERCOM3 / PAD[1]	SERCOM7 / PAD[0]	-	TCC1 / WO[3]	-	-	-	SDHC1 / SDDAT[3]	-	-	-	GCLK / IO[7]	-	VDD	I/O, Hi-Z
70	A10	PA20	EXTINT[4]	-	-	-	-	-	X14 / Y14	SERCOM5 / PAD[2]	SERCOM3 / PAD[2]	TC7 / WO[0]	TCC1 / WO[4]	TCC0 / WO[0]	-	-	SDHC1 / SDCMD	FS[0]	DATA[4]	GMDC	-	-	VDD	I/O, Hi-Z

.....continued

100-pin TOFP	100-pin TFBGA	Port Group:		A	B (2)					C (5)	D (5)	E	F (4)	G	H	I	J	K	L	M	N	Power Rail	Reset State
		Pad Name	EIC		ANAREF	ADCO	ADC1	AC	DAC														
71	F8	PA21	EXTINT[5]	-	-	-	-	-	X15 / Y15	SERCOM5 / PAD[3]	SERCOM3 / PAD[3]	TC7 / WO[1]	TCC1 / WO[5]	TCC0 / WO[1]	-	SDHC1 / SDCK	SDO	DATA[5]	GMDIO	-	-	VDD	I/O, Hi-Z
72	B10	PA22 (6)	EXTINT[6]	-	-	-	-	-	X16 / Y16	SERCOM3 / PAD[0]	SERCOM5 / PAD[1]	TC4 / WO[0]	TCC1 / WO[6]	TCC0 / WO[2]	-	CAN0 / TX	SDI	DATA[6]	-	-	IN[6]	VDD	I/O, Hi-Z
73	C9	PA23 (6)	EXTINT[7]	-	-	-	-	-	X17 / Y17	SERCOM3 / PAD[1]	SERCOM5 / PAD[0]	TC4 / WO[1]	TCC1 / WO[7]	TCC0 / WO[3]	USB / SOF_1KHZ	CAN0 / RX	FS[1]	DATA[7]	-	-	IN[7]	VDD	I/O, Hi-Z
74	D10	PA24	EXTINT[8]	-	-	-	-	-	-	SERCOM3 / PAD[2]	SERCOM5 / PAD[2]	TC5 / WO[0]	TCC2 / WO[2]	PDEC / QDI[0]	USB / DM	CAN0 / TX	-	-	-	-	IN[8]	VDD	I, PD
75	C10	PA25	EXTINT[9]	-	-	-	-	-	-	SERCOM3 / PAD[3]	SERCOM5 / PAD[3]	TC5 / WO[1]	-	PDEC / QDI[1]	USB / DP	CAN0 / RX	-	-	-	-	OUT[2]	VDD	I, PD
76	A8	VSS	-	-	-	-	-	-	-	-	-	-	-	-	-	-	-	-	-	-	-	-	-
77	A9	VDD	-	-	-	-	-	-	-	-	-	-	-	-	-	-	-	-	-	-	-	-	-
78	B9	PB22	EXTINT[6]	-	-	-	-	-	-	SERCOM1 / PAD[2]	SERCOM5 / PAD[2]	TC7 / WO[0]	-	PDEC / QDI[2]	USB / SOF_1KHZ	-	-	-	-	GCLK / IO[0]	IN[0]	VDD	I/O, Hi-Z
79	B8	PB23	EXTINT[7]	-	-	-	-	-	-	SERCOM1 / PAD[3]	SERCOM5 / PAD[3]	TC7 / WO[1]	-	PDEC / QDI[0]	-	-	-	-	-	GCLK / IO[1]	OUT[0]	VDD	I/O, Hi-Z
80	C8	PB24	EXTINT[8]	-	-	-	-	-	-	SERCOM0 / PAD[0]	SERCOM2 / PAD[1]	-	-	PDEC / QDI[1]	-	-	-	-	-	AC / CMP[0]	-	VDD	I/O, Hi-Z
81	D7	PB25	EXTINT[9]	-	-	-	-	-	-	SERCOM0 / PAD[1]	SERCOM2 / PAD[0]	-	-	PDEC / QDI[2]	-	-	-	-	-	AC / CMP[1]	-	VDD	I/O, Hi-Z
82	C7	PC24	EXTINT[8]	-	-	-	-	-	-	SERCOM0 / PAD[2]	SERCOM2 / PAD[2]	-	-	-	CORTEX_CM4 / TRACEDATA[3]	-	-	-	-	-	-	VDD	I/O, Hi-Z
83	B7	PC25	EXTINT[9]	-	-	-	-	-	-	SERCOM0 / PAD[3]	SERCOM2 / PAD[3]	-	-	-	CORTEX_CM4 / TRACEDATA[2]	-	-	-	-	-	-	VDD	I/O, Hi-Z
84	A7	PC26	EXTINT[10]	-	-	-	-	-	-	-	-	-	-	-	CORTEX_CM4 / TRACEDATA[1]	-	-	-	-	-	-	VDD	I/O, Hi-Z
85	A6	PC27	EXTINT[11]	-	-	-	-	-	-	SERCOM1 / PAD[0]	-	-	-	-	CORTEX_CM4 / TRACECLK	-	-	-	-	CORTEX_M4 / SWO	IN[4]	VDD	I/O, Hi-Z
86	B6	PC28	EXTINT[12]	-	-	-	-	-	-	SERCOM1 / PAD[1]	-	-	-	-	CORTEX_CM4 / TRACEDATA[0]	-	-	-	-	-	IN[5]	VDD	I/O, Hi-Z
87	C6	PA27	EXTINT[11]	-	-	-	-	-	X18 / Y18	-	-	-	-	-	-	-	-	-	-	GCLK / IO[1]	-	VDD	I/O, Hi-Z

.....continued

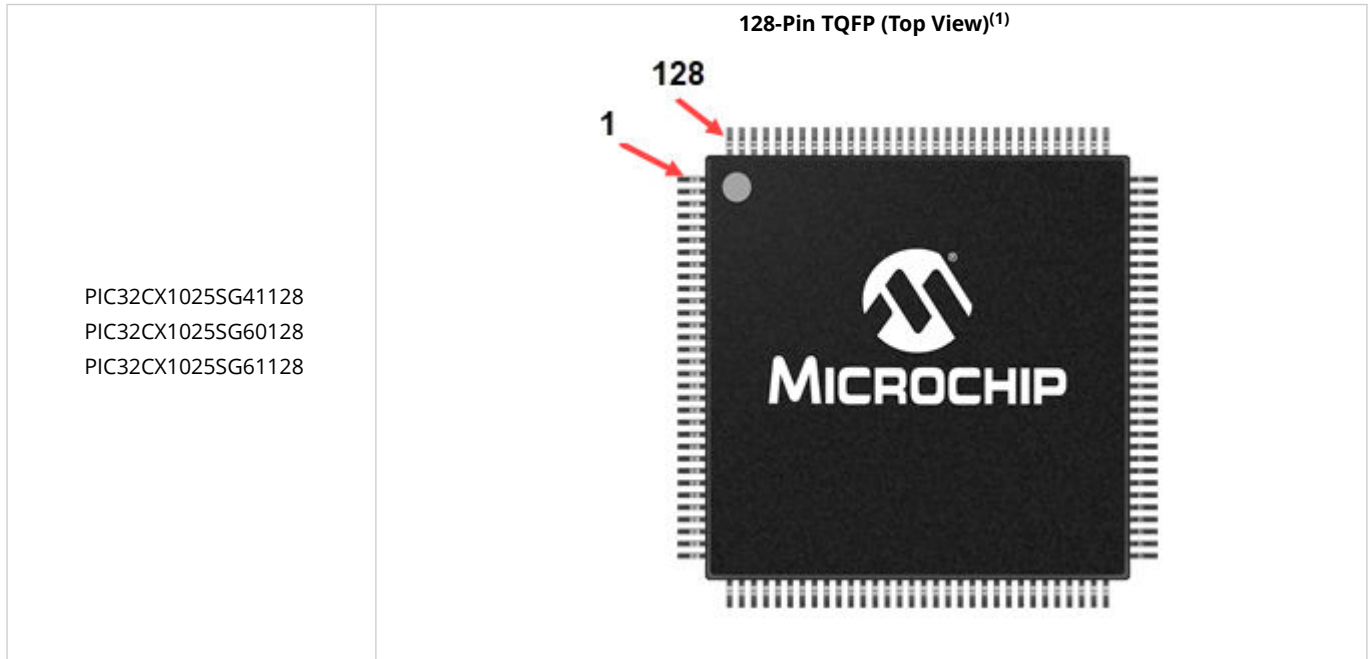
	100-pin TOFP	100-pin TFBGA	Port Group:		A	B (2)				C (5)	D (5)	E	F (4)	G	H	I	J	K	L	M	N	Power Rail	Reset State	
			Pad Name	EIC		ANAREF	ADCO	ADC1	AC															DAC
88	C5	RESET	-	-	-	-	-	-	-	-	-	-	-	-	-	-	-	-	-	-	-	-	VDD	-
89	A5	VDDCO RE	-	-	-	-	-	-	-	-	-	-	-	-	-	-	-	-	-	-	-	-	-	-
90	A2	VSS	-	-	-	-	-	-	-	-	-	-	-	-	-	-	-	-	-	-	-	-	-	-
91	A4	VSW	-	-	-	-	-	-	-	-	-	-	-	-	-	-	-	-	-	-	-	-	-	-
92	A3	VDD	-	-	-	-	-	-	-	-	-	-	-	-	-	-	-	-	-	-	-	-	-	-
93	B5	PA30	EXTINT[14]	-	-	-	-	-	X19 / Y19	SERCOM7 / PAD[2]	SERCOM1 / PAD[2]	TC6 / WO[0]	TCC2 / WO[0]	-	CORTEX_CM4 / SWCLK	-	-	-	-	GCLK / IO[0]	IN[3]	VDD	I, PU	
94	C4	PA31	EXTINT[15]	-	-	-	-	-	-	SERCOM7 / PAD[3]	SERCOM1 / PAD[3]	TC6 / WO[1]	TCC2 / WO[1]	-	CORTEX_CM4 / SWDIO	-	-	-	-	-	OUT[1]	VDD	I/O, Hi-Z	
95	A1	PB30	EXTINT[14]	-	-	-	-	-	-	SERCOM7 / PAD[0]	SERCOM5 / PAD[1]	TC0 / WO[0]	TCC4 / WO[0]	TCC0 / WO[6]	CORTEX_CM4 / SWO	-	-	-	-	-	-	VDD	I/O, Hi-Z	
96	C3	PB31	EXTINT[15]	-	-	-	-	-	-	SERCOM7 / PAD[1]	SERCOM5 / PAD[0]	TC0 / WO[1]	TCC4 / WO[1]	TCC0 / WO[7]	-	-	-	-	-	-	-	VDD	I/O, Hi-Z	
97	B4	PB00	EXTINT[0]	-	AIN[12]	-	-	-	X30 / Y30	-	SERCOM5 / PAD[2]	TC7 / WO[0]	-	-	-	-	-	-	-	-	IN[1]	VSWOUT	I/O, Hi-Z	
98	B3	PB01	EXTINT[1]	-	AIN[13]	-	-	-	X31 / Y31	-	SERCOM5 / PAD[3]	TC7 / WO[1]	-	-	-	-	-	-	-	-	IN[2]	VSWOUT	I/O, Hi-Z	
99	D4	PB02	EXTINT[2]	-	AIN[14]	-	-	-	X20 / Y20	-	SERCOM5 / PAD[0]	TC6 / WO[0]	TCC2 / WO[2]	-	-	-	-	-	-	-	OUT[0]	VSWOUT	I/O, Hi-Z	
100	B2	PB03	EXTINT[3]	-	AIN[15]	-	-	-	X21 / Y21	-	SERCOM5 / PAD[1]	TC6 / WO[1]	-	-	-	-	-	-	-	-	-	VSWOUT	I/O, Hi-Z	
(3)	(3)	PB26	-	-	-	-	-	-	-	SERCOM2 / PAD[0]	-	-	-	-	-	-	-	-	-	-	-	VDD	-	
(3)	(3)	PB27	-	-	-	-	-	-	-	SERCOM2 / PAD[1]	-	-	-	-	-	-	-	-	-	-	-	VDD	-	
(3)	(3)	PB28	-	-	-	-	-	-	-	SERCOM2 / PAD[2]	-	-	-	-	-	-	-	-	-	-	-	VDD	-	
(3)	(3)	PB29	-	-	-	-	-	-	-	-	-	-	-	-	-	-	-	-	-	-	-	VDD	-	
(3)	(3)	PC04	-	-	-	-	-	-	-	-	-	-	-	-	-	-	-	-	-	-	-	VDD	-	



**Notes:**

1. Package 4NB (100-pin TQFP) has an exposed pad that is an additional ground. This must be soldered to the board's ground plane to provide additional noise immunity and thermal dissipation.
2. All analog pin functions are on the peripheral function B. The peripheral function B must be selected to disable the digital control of the pin. The AC has analog signals on the peripheral function B and digital signals on the peripheral function M.
3. PIC32CX SG60/SG61 only: PB26, PB27, PB28, PB29 and PC04 are internal signals reserved for the HSM interconnection.
4. Refer to [TCC Configuration Summary](#) table for the list of supported features for each peripheral instance.
5. I<sup>2</sup>C is not supported on all SERCOM pins. Refer to [SERCOM I<sup>2</sup>C Pinout](#) table for the list of supported features for each peripheral instance.
6. The following High-Sink pins have different properties than the regular pins: PA08, PA09, PA12, PA13, PA16, PA17, PA22, and PA23.

### 4.3 128-pin TQFP



**Note:**

1. The XCB (128-pin TQFP) package has an exposed pad.

**Table 4-3. 128-pin TQFP I/O PINMUX (PIC32CX SG41)**

128-Pin TQFP	Port Group:	Pad Name	A	B (2)				C (4)	D (4)	E	F (2)	G	H	I	J	K	L	M	N	Power Rail	Reset State
				EIC	ANAREF	ADCO	ADC1														
1	PA00	EXTINT[0]	-	-	-	-	-	-	SERCOM1 / PAD[0]	TC2 / WO[0]	-	-	-	-	-	-	-	-	-	VSWOUT	I/O, Hi-Z
2	PA01	EXTINT[1]	-	-	-	-	-	-	SERCOM1 / PAD[1]	TC2 / WO[1]	-	-	-	-	-	-	-	-	-	VSWOUT	I/O, Hi-Z
3	PC00	EXTINT[0]	-	-	AIN[10]	-	-	-	-	-	-	-	-	-	-	-	-	-	-	VSWOUT	I/O, Hi-Z
4	PC01	EXTINT[1]	-	-	AIN[11]	-	-	-	-	-	-	-	-	-	-	-	-	-	-	VSWOUT	I/O, Hi-Z
5	AVSS	-	-	-	-	-	-	-	-	-	-	-	-	-	-	-	-	-	-	-	-
6	AVDD	-	-	-	-	-	-	-	-	-	-	-	-	-	-	-	-	-	-	-	-
7	PC02	EXTINT[2]	-	-	AIN[4]	-	-	-	-	-	-	-	-	-	-	-	-	-	-	AVDD	I/O, Hi-Z
8	PC03	EXTINT[3]	-	-	AIN[5]	-	-	-	-	-	-	-	-	-	-	-	-	-	-	AVDD	I/O, Hi-Z
9	PA02	EXTINT[2]	-	AIN[0]	-	-	VOUT[0]	-	-	-	-	-	-	-	-	-	-	-	-	AVDD	I/O, Hi-Z
10	PA03	EXTINT[3]	VREFA	AIN[1]	-	-	-	X0 / Y0	-	-	-	-	-	-	-	-	-	-	-	AVDD	I/O, Hi-Z
11	PB04	EXTINT[4]	-	-	AIN[6]	-	-	X22 / Y22	-	-	-	-	-	-	-	-	-	-	-	AVDD	I/O, Hi-Z
12	PB05	EXTINT[5]	-	-	AIN[7]	-	-	X23 / Y23	-	-	-	-	-	-	-	-	-	-	-	AVDD	I/O, Hi-Z
13	PD00	EXTINT[0]	-	-	AIN[14]	-	-	-	-	-	-	-	-	-	-	-	-	-	-	AVDD	I/O, Hi-Z
14	AVSS	-	-	-	-	-	-	-	-	-	-	-	-	-	-	-	-	-	-	-	-
15	AVDD	-	-	-	-	-	-	-	-	-	-	-	-	-	-	-	-	-	-	-	-
16	PD01	EXTINT[1]	-	-	AIN[15]	-	-	-	-	-	-	-	-	-	-	-	-	-	-	AVDD	I/O, Hi-Z
17	PB06	EXTINT[6]	-	-	AIN[8]	-	-	X24 / Y24	-	-	-	-	-	-	-	-	-	-	-	AVDD	I/O, Hi-Z
18	PB07	EXTINT[7]	-	-	AIN[9]	-	-	X25 / Y25	-	-	-	-	-	-	-	-	-	-	-	AVDD	I/O, Hi-Z
19	PB08	EXTINT[8]	-	AIN[2]	AIN[0]	-	-	X1 / Y1	-	SERCOM4 / PAD[0]	TC4 / WO[0]	-	-	-	-	-	-	-	-	AVDD	I/O, Hi-Z
20	PB09	EXTINT[9]	-	AIN[3]	AIN[1]	-	-	X2 / Y2	-	SERCOM4 / PAD[1]	TC4 / WO[1]	-	-	-	-	-	-	-	-	AVDD	I/O, Hi-Z
21	PA04	EXTINT[4]	VREFB	AIN[4]	-	AIN[0]	-	X3 / Y3	-	SERCOM0 / PAD[0]	TC0 / WO[0]	-	-	-	-	-	-	-	-	AVDD	I/O, Hi-Z

.....continued

128-Pin TOFP	Port Group:	A	B (2)						C (4)	D (4)	E	F (3)	G	H	I	J	K	L	M	N	Power Rail	Reset State
	Pad Name	EIC	ANAREF	ADC0	ADC1	AC	DAC	PTC	SERCOM	SERCOM	TC	TCC	TCC, PDEC	CAN1, QSPI, USB, CORTEX_GM4	CAN0, SDHC	I2S	PCC	GMAC	GCLK, AC	CCL		
22	PA05	EXTINT[5]	-	AIN[5]	-	AIN[1]	VOUT[1]	-	-	SERCOM0 / PAD[1]	TC0 / WO[1]	-	-	-	-	-	-	-	-	IN[1]	AVDD	I/O, Hi-Z
23	PA06	EXTINT[6]	VREFC	AIN[6]	-	AIN[2]	-	X4 / Y4	-	SERCOM0 / PAD[2]	TC1 / WO[0]	-	-	-	SDHC0 / SDCD	-	-	-	-	IN[2]	AVDD	I/O, Hi-Z
24	PA07	EXTINT[7]	-	AIN[7]	-	AIN[3]	-	X5 / Y5	-	SERCOM0 / PAD[3]	TC1 / WO[1]	-	-	-	SDHC0 / SDWP	-	-	-	-	OUT[0]	AVDD	I/O, Hi-Z
25	AVSS	-	-	-	-	-	-	-	-	-	-	-	-	-	-	-	-	-	-	-	-	-
26	AVDD	-	-	-	-	-	-	-	-	-	-	-	-	-	-	-	-	-	-	-	-	-
27	PC04	EXTINT[4]	-	-	-	-	-	-	-	SERCOM6 / PAD[0]	-	-	TCC0 / WO[0]	-	-	-	-	-	-	-	VDD	I/O, Hi-Z
28	PC05	EXTINT[5]	-	-	-	-	-	-	-	SERCOM6 / PAD[1]	-	-	-	-	-	-	-	-	-	-	VDD	I/O, Hi-Z
29	PC06	EXTINT[6]	-	-	-	-	-	-	-	SERCOM6 / PAD[2]	-	-	-	-	SDHC0 / SDCD	-	-	-	-	-	VDD	I/O, Hi-Z
30	PC07	EXTINT[9]	-	-	-	-	-	-	-	SERCOM6 / PAD[3]	-	-	-	-	SDHC0 / SDWP	-	-	-	-	-	VDD	I/O, Hi-Z
31	VSS	-	-	-	-	-	-	-	-	-	-	-	-	-	-	-	-	-	-	-	-	-
32	VDD	-	-	-	-	-	-	-	-	-	-	-	-	-	-	-	-	-	-	-	-	-
33	PA08 (5)	NMI	-	AIN[8]	AIN[2]	-	-	X6 / Y6	SERCOM0 / PAD[0]	SERCOM2 / PAD[1]	TC0 / WO[0]	TCC0 / WO[0]	TCC1 / WO[4]	QSPI / DATA[0]	SDHC0 / SDCMD	MCK[0]	-	-	-	IN[3]	VDD	I/O, Hi-Z
34	PA09 (5)	EXTINT[9]	-	AIN[9]	AIN[3]	-	-	X7 / Y7	SERCOM0 / PAD[1]	SERCOM2 / PAD[0]	TC0 / WO[1]	TCC0 / WO[1]	TCC1 / WO[5]	QSPI / DATA[1]	SDHC0 / SDDAT[0]	FS[0]	-	-	-	IN[4]	VDD	I/O, Hi-Z
35	PA10	EXTINT[10]	-	AIN[10]	-	-	-	X8 / Y8	SERCOM0 / PAD[2]	SERCOM2 / PAD[2]	TC1 / WO[0]	TCC0 / WO[2]	TCC1 / WO[6]	QSPI / DATA[2]	SDHC0 / SDDAT[1]	SCK[0]	-	-	GCLK / IO[4]	IN[5]	VDD	I/O, Hi-Z
36	PA11	EXTINT[11]	-	AIN[11]	-	-	-	X9 / Y9	SERCOM0 / PAD[3]	SERCOM2 / PAD[3]	TC1 / WO[1]	TCC0 / WO[3]	TCC1 / WO[7]	QSPI / DATA[3]	SDHC0 / SDDAT[2]	SDO	-	-	GCLK / IO[5]	OUT[1]	VDD	I/O, Hi-Z
37	VDD	-	-	-	-	-	-	-	-	-	-	-	-	-	-	-	-	-	-	-	-	-
38	VSS	-	-	-	-	-	-	-	-	-	-	-	-	-	-	-	-	-	-	-	-	-
39	PB10	EXTINT[10]	-	-	-	-	-	-	-	SERCOM4 / PAD[2]	TC5 / WO[0]	TCC0 / WO[4]	TCC1 / WO[0]	QSPI / SCK	SDHC0 / SDDAT[3]	SDI	-	-	GCLK / IO[4]	IN[11]	VDD	I/O, Hi-Z
40	PB11	EXTINT[11]	-	-	-	-	-	-	-	SERCOM4 / PAD[3]	TC5 / WO[1]	TCC0 / WO[5]	TCC1 / WO[1]	QSPI / CS	SDHC0 / SDCK	FS[1]	-	-	GCLK / IO[5]	OUT[1]	VDD	I/O, Hi-Z

.....continued

128-Pin TOFP	Port Group:	A	B (2)						C (4)	D (4)	E	F (3)	G	H	I	J	K	L	M	N	Power Rail	Reset State
	Pad Name	EIC	ANAREF	ADC0	ADC1	AC	DAC	PTC	SERCOM	SERCOM	TC	TCC	TCC, PDEC	CAN1, QSPI, USB, CORTEX_GM4	CAN0, SDHC	I2S	PCC	GMAC	GCLK, AC	CCL		
41	PB12	EXTINT[12]	-	-	-	-	-	X26 / Y26	SERCOM4 / PAD[0]	-	TC4 / WO[0]	TCC3 / WO[0]	TCC0 / WO[0]	CAN1 / TX	SDHC0 / SDCD	SCK[1]	-	-	GCLK / IO[6]	-	VDD	I/O, Hi-Z
42	PB13	EXTINT[13]	-	-	-	-	-	X27 / Y27	SERCOM4 / PAD[1]	-	TC4 / WO[1]	TCC3 / WO[1]	TCC0 / WO[1]	CAN1 / RX	SDHC0 / SDWP	MCK[1]	-	-	GCLK / IO[7]	-	VDD	I/O, Hi-Z
43	PB14	EXTINT[14]	-	-	-	-	-	X28 / Y28	SERCOM4 / PAD[2]	-	TC5 / WO[0]	TCC4 / WO[0]	TCC0 / WO[2]	CAN1 / TX	-	-	DATA[8]	GMDC	GCLK / IO[0]	IN[9]	VDD	I/O, Hi-Z
44	PB15	EXTINT[15]	-	-	-	-	-	X29 / Y29	SERCOM4 / PAD[3]	-	TC5 / WO[1]	TCC4 / WO[1]	TCC0 / WO[3]	CAN1 / RX	-	-	DATA[9]	GMDIO	GCLK / IO[1]	IN[10]	VDD	I/O, Hi-Z
45	VSS	-	-	-	-	-	-	-	-	-	-	-	-	-	-	-	-	-	-	-	-	-
46	VDD	-	-	-	-	-	-	-	-	-	-	-	-	-	-	-	-	-	-	-	-	-
47	PD08 (5)	EXTINT[3]	-	-	-	-	-	-	SERCOM7 / PAD[0]	SERCOM6 / PAD[1]	-	TCC0 / WO[1]	-	-	-	-	-	-	-	-	VDD	I/O, Hi-Z
48	PD09 (5)	EXTINT[4]	-	-	-	-	-	-	SERCOM7 / PAD[1]	SERCOM6 / PAD[0]	-	TCC0 / WO[2]	-	-	-	-	-	-	-	-	VDD	I/O, Hi-Z
49	PD10	EXTINT[5]	-	-	-	-	-	-	SERCOM7 / PAD[2]	SERCOM6 / PAD[2]	-	TCC0 / WO[3]	-	-	-	-	-	-	-	-	VDD	I/O, Hi-Z
50	PD11	EXTINT[6]	-	-	-	-	-	-	SERCOM7 / PAD[3]	SERCOM6 / PAD[3]	-	TCC0 / WO[4]	-	-	-	-	-	-	-	-	VDD	I/O, Hi-Z
51	PD12	EXTINT[7]	-	-	-	-	-	-	-	-	-	TCC0 / WO[5]	-	-	-	-	-	-	-	-	VDD	I/O, Hi-Z
52	PC10	EXTINT[10]	-	-	-	-	-	-	SERCOM6 / PAD[2]	SERCOM7 / PAD[2]	-	TCC0 / WO[0]	TCC1 / WO[4]	-	-	-	-	-	-	-	VDD	I/O, Hi-Z
53	VSS	-	-	-	-	-	-	-	-	-	-	-	-	-	-	-	-	-	-	-	-	-
54	VDD	-	-	-	-	-	-	-	-	-	-	-	-	-	-	-	-	-	-	-	-	-
55	PC11	EXTINT[11]	-	-	-	-	-	-	SERCOM6 / PAD[3]	SERCOM7 / PAD[3]	-	TCC0 / WO[1]	TCC1 / WO[5]	-	-	-	-	GMDC	-	-	VDD	I/O, Hi-Z
56	PC12	EXTINT[12]	-	-	-	-	-	-	SERCOM7 / PAD[0]	SERCOM6 / PAD[1]	-	TCC0 / WO[2]	TCC1 / WO[6]	-	-	-	DATA[10]	GMDIO	-	-	VDD	I/O, Hi-Z
57	PC13	EXTINT[13]	-	-	-	-	-	-	SERCOM7 / PAD[1]	SERCOM6 / PAD[0]	-	TCC0 / WO[3]	TCC1 / WO[7]	-	-	-	DATA[11]	-	-	-	VDD	I/O, Hi-Z
58	PC14	EXTINT[14]	-	-	-	-	-	-	SERCOM7 / PAD[2]	SERCOM6 / PAD[2]	-	TCC0 / WO[4]	TCC1 / WO[0]	-	-	-	DATA[12]	GRX[3]	-	-	VDD	I/O, Hi-Z

.....continued

128-Pin TOFP	Port Group:	A	B (2)						C (4)	D (4)	E	F (3)	G	H	I	J	K	L	M	N	Power Rail	Reset State
	Pad Name	EIC	ANAREF	ADC0	ADC1	AC	DAC	PTC	SERCOM	SERCOM	TC	TCC	TCC, PDEC	CAN1, QSPI, USB, CORTEX_DMA4	CAN0, SDHC	I2S	PCC	GMAC	GCLK, AC	CCL		
59	PC15	EXTINT[15]	-	-	-	-	-	-	SERCOM7 / PAD[3]	SERCOM6 / PAD[3]	-	TCC0 / WO[5]	TCC1 / WO[1]	-	-	-	DATA[13]	GRX[2]	-	-	VDD	I/O, Hi-Z
60	PA12 (5)	EXTINT[12]	-	-	-	-	-	-	SERCOM2 / PAD[0]	SERCOM4 / PAD[1]	TC2 / WO[0]	TCC0 / WO[6]	TCC1 / WO[2]	-	SDHC0 / SDCD	-	DEN1	GRX[1]	AC / CMP[0]	-	VDD	I/O, Hi-Z
61	PA13 (5)	EXTINT[13]	-	-	-	-	-	-	SERCOM2 / PAD[1]	SERCOM4 / PAD[0]	TC2 / WO[1]	TCC0 / WO[7]	TCC1 / WO[3]	-	SDHC0 / SDWP	-	DEN2	GRX[0]	AC / CMP[1]	-	VDD	I/O, Hi-Z
62	PA14	EXTINT[14]	-	-	-	-	-	-	SERCOM2 / PAD[2]	SERCOM4 / PAD[2]	TC3 / WO[0]	TCC2 / WO[0]	TCC1 / WO[2]	-	-	-	CLK	GTXCCK	GCLK / IO[0]	-	VDD	I/O, Hi-Z
63	PA15	EXTINT[15]	-	-	-	-	-	-	SERCOM2 / PAD[3]	SERCOM4 / PAD[3]	TC3 / WO[1]	TCC2 / WO[1]	TCC1 / WO[3]	-	-	-	-	GRXER	GCLK / IO[1]	-	VDD	I/O, Hi-Z
64	VSS	-	-	-	-	-	-	-	-	-	-	-	-	-	-	-	-	-	-	-	-	-
65	VDD	-	-	-	-	-	-	-	-	-	-	-	-	-	-	-	-	-	-	-	-	-
66	PA16 (5)	EXTINT[0]	-	-	-	-	-	X10 / Y10	SERCOM1 / PAD[0]	SERCOM3 / PAD[1]	TC2 / WO[0]	TCC1 / WO[0]	TCC0 / WO[4]	-	-	-	DATA[0]	GCRS	GCLK / IO[2]	IN[0]	VDD	I/O, Hi-Z
67	PA17 (5)	EXTINT[1]	-	-	-	-	-	X11 / Y11	SERCOM1 / PAD[1]	SERCOM3 / PAD[0]	TC2 / WO[1]	TCC1 / WO[1]	TCC0 / WO[5]	-	-	-	DATA[1]	GTXEN	GCLK / IO[3]	IN[1]	VDD	I/O, Hi-Z
68	PA18	EXTINT[2]	-	-	-	-	-	X12 / Y12	SERCOM1 / PAD[2]	SERCOM3 / PAD[2]	TC3 / WO[0]	TCC1 / WO[2]	TCC0 / WO[6]	-	-	-	DATA[2]	GTX[0]	AC / CMP[0]	IN[2]	VDD	I/O, Hi-Z
69	PA19	EXTINT[3]	-	-	-	-	-	X13 / Y13	SERCOM1 / PAD[3]	SERCOM3 / PAD[3]	TC3 / WO[1]	TCC1 / WO[3]	TCC0 / WO[7]	-	-	-	DATA[3]	GTX[1]	AC / CMP[1]	OUT[0]	VDD	I/O, Hi-Z
70	PC16	EXTINT[0]	-	-	-	-	-	-	SERCOM6 / PAD[0]	SERCOM0 / PAD[1]	-	TCC0 / WO[0]	PDEC / QDI[0]	-	-	-	-	GTX[2]	-	-	VDD	I/O, Hi-Z
71	PC17	EXTINT[1]	-	-	-	-	-	-	SERCOM6 / PAD[1]	SERCOM0 / PAD[0]	-	TCC0 / WO[1]	PDEC / QDI[1]	-	-	-	-	GTX[3]	-	-	VDD	I/O, Hi-Z
72	PC18	EXTINT[2]	-	-	-	-	-	-	SERCOM6 / PAD[2]	SERCOM0 / PAD[2]	-	TCC0 / WO[2]	PDEC / QDI[2]	-	-	-	-	GRXCCK	-	-	VDD	I/O, Hi-Z
73	PC19	EXTINT[3]	-	-	-	-	-	-	SERCOM6 / PAD[3]	SERCOM0 / PAD[3]	-	TCC0 / WO[3]	-	-	-	-	-	GTXER	-	-	VDD	I/O, Hi-Z
74	PC20	EXTINT[4]	-	-	-	-	-	-	-	-	-	TCC0 / WO[4]	-	SDHC1 / SDCD	-	-	-	GRXDV	-	IN[9]	VDD	I/O, Hi-Z
75	PC21	EXTINT[5]	-	-	-	-	-	-	-	-	-	TCC0 / WO[5]	-	SDHC1 / SDWP	-	-	-	GCOL	-	IN[10]	VDD	I/O, Hi-Z

.....continued

128-Pin TOFP	Port Group:	A	B (2)						C (4)	D (4)	E	F (3)	G	H	I	J	K	L	M	N	Power Rail	Reset State
	Pad Name	EIC	ANAREF	ADC0	ADC1	AC	DAC	PTC	SERCOM	SERCOM	TC	TCC	TCC, PDEC	CAN1, QSPI, USB, CORTEX_GM4	CAN0, SDHC	I2S	PCC	GMAC	GCLK, AC	CCL		
76	PC22	EXTINT[6]	-	-	-	-	-	-	SERCOM1 / PAD[0]	SERCOM3 / PAD[1]	-	TCC0 / WO[6]	-	-	-	-	-	GMDC	-	-	VDD	I/O, Hi-Z
77	PC23	EXTINT[7]	-	-	-	-	-	-	SERCOM1 / PAD[1]	SERCOM3 / PAD[0]	-	TCC0 / WO[7]	-	-	-	-	-	GMDIO	-	-	VDD	I/O, Hi-Z
78	VSS	-	-	-	-	-	-	-	-	-	-	-	-	-	-	-	-	-	-	-	-	-
79	VDD	-	-	-	-	-	-	-	-	-	-	-	-	-	-	-	-	-	-	-	-	-
80	PD20	EXTINT[10]	-	-	-	-	-	-	SERCOM1 / PAD[2]	SERCOM3 / PAD[2]	-	TCC1 / WO[0]	-	-	SDHC1 / SDCD	-	-	-	-	-	VDD	I/O, Hi-Z
81	PD21	EXTINT[11]	-	-	-	-	-	-	SERCOM1 / PAD[3]	SERCOM3 / PAD[3]	-	TCC1 / WO[1]	-	-	SDHC1 / SDWP	-	-	-	-	-	VDD	I/O, Hi-Z
82	PB16	EXTINT[0]	-	-	-	-	-	-	SERCOM5 / PAD[0]	-	TC6 / WO[0]	TCC3 / WO[0]	TCC0 / WO[4]	-	SDHC1 / SDCD	SCK[0]	-	-	GCLK / IO[2]	IN[11]	VDD	I/O, Hi-Z
83	PB17	EXTINT[1]	-	-	-	-	-	-	SERCOM5 / PAD[1]	-	TC6 / WO[1]	TCC3 / WO[1]	TCC0 / WO[5]	-	SDHC1 / SDWP	MCK[0]	-	-	GCLK / IO[3]	OUT[3]	VDD	I/O, Hi-Z
84	PB18	EXTINT[2]	-	-	-	-	-	-	SERCOM5 / PAD[2]	SERCOM7 / PAD[2]	-	TCC1 / WO[0]	PDEC / QDI[0]	-	SDHC1 / SDDAT[0]	-	-	-	GCLK / IO[4]	-	VDD	I/O, Hi-Z
85	PB19	EXTINT[3]	-	-	-	-	-	-	SERCOM5 / PAD[3]	SERCOM7 / PAD[3]	-	TCC1 / WO[1]	PDEC / QDI[1]	-	SDHC1 / SDDAT[1]	-	-	-	GCLK / IO[5]	-	VDD	I/O, Hi-Z
86	PB20	EXTINT[4]	-	-	-	-	-	-	SERCOM3 / PAD[0]	SERCOM7 / PAD[1]	-	TCC1 / WO[2]	PDEC / QDI[2]	-	SDHC1 / SDDAT[2]	-	-	-	GCLK / IO[6]	-	VDD	I/O, Hi-Z
87	PB21	EXTINT[5]	-	-	-	-	-	-	SERCOM3 / PAD[1]	SERCOM7 / PAD[0]	-	TCC1 / WO[3]	-	-	SDHC1 / SDDAT[3]	-	-	-	GCLK / IO[7]	-	VDD	I/O, Hi-Z
88	PA20	EXTINT[4]	-	-	-	-	-	X14 / Y14	SERCOM5 / PAD[2]	SERCOM3 / PAD[2]	TC7 / WO[0]	TCC1 / WO[4]	TCC0 / WO[0]	-	SDHC1 / SDCMD	FS[0]	DATA[4]	GMDC	-	-	VDD	I/O, Hi-Z
89	PA21	EXTINT[5]	-	-	-	-	-	X15 / Y15	SERCOM5 / PAD[3]	SERCOM3 / PAD[3]	TC7 / WO[1]	TCC1 / WO[5]	TCC0 / WO[1]	-	SDHC1 / SDCK	SDO	DATA[5]	GMDIO	-	-	VDD	I/O, Hi-Z
90	VSS	-	-	-	-	-	-	-	-	-	-	-	-	-	-	-	-	-	-	-	-	-
91	VDD	-	-	-	-	-	-	-	-	-	-	-	-	-	-	-	-	-	-	-	-	-
92	PA22 (5)	EXTINT[6]	-	-	-	-	-	X16 / Y16	SERCOM3 / PAD[0]	SERCOM5 / PAD[1]	TC4 / WO[0]	TCC1 / WO[6]	TCC0 / WO[2]	-	CAN0 / TX	SDI	DATA[6]	-	-	IN[6]	VDD	I/O, Hi-Z
93	PA23 (5)	EXTINT[7]	-	-	-	-	-	X17 / Y17	SERCOM3 / PAD[1]	SERCOM5 / PAD[0]	TC4 / WO[1]	TCC1 / WO[7]	TCC0 / WO[3]	USB / SOF_1KHZ	CAN0 / RX	FS[1]	DATA[7]	-	-	IN[7]	VDD	I/O, Hi-Z

.....continued

128-Pin TOFP	Port Group:	A	B (2)						C (4)	D (4)	E	F (3)	G	H	I	J	K	L	M	N	Power Rail	Reset State
	Pad Name	EIC	ANAREF	ADC0	ADC1	AC	DAC	PTC	SERCOM	SERCOM	TC	TCC	TCC, PDEC	CAN1, QSPI, USB, CORTEX_GM4	CAN0, SDHC	I2S	PCC	GMAC	GCLK, AC	CCL		
94	PA24	EXTINT[8]	-	-	-	-	-	-	SERCOM3 / PAD[2]	SERCOM5 / PAD[2]	TC5 / WO[0]	TCC2 / WO[2]	PDEC / QDI[0]	USB / DM	CAN0 / TX	-	-	-	-	IN[8]	VDD	I, PD
95	PA25	EXTINT[9]	-	-	-	-	-	-	SERCOM3 / PAD[3]	SERCOM5 / PAD[3]	TC5 / WO[1]	-	PDEC / QDI[1]	USB / DP	CAN0 / RX	-	-	-	-	OUT[2]	VDD	I, PD
96	VSS	-	-	-	-	-	-	-	-	-	-	-	-	-	-	-	-	-	-	-	-	-
97	VDD	-	-	-	-	-	-	-	-	-	-	-	-	-	-	-	-	-	-	-	-	-
98	PB22	EXTINT[6]	-	-	-	-	-	-	SERCOM1 / PAD[2]	SERCOM5 / PAD[2]	TC7 / WO[0]	-	PDEC / QDI[2]	USB / SOF_1KHZ	-	-	-	-	GCLK / IO[0]	IN[0]	VDD	I/O, Hi-Z
99	PB23	EXTINT[7]	-	-	-	-	-	-	SERCOM1 / PAD[3]	SERCOM5 / PAD[3]	TC7 / WO[1]	-	PDEC / QDI[0]	-	-	-	-	-	GCLK / IO[1]	OUT[0]	VDD	I/O, Hi-Z
100	PB24	EXTINT[8]	-	-	-	-	-	-	SERCOM0 / PAD[0]	SERCOM2 / PAD[1]	-	-	PDEC / QDI[1]	-	-	-	-	-	AC / CMP[0]	-	VDD	I/O, Hi-Z
101	PB25	EXTINT[9]	-	-	-	-	-	-	SERCOM0 / PAD[1]	SERCOM2 / PAD[0]	-	-	PDEC / QDI[2]	-	-	-	-	-	AC / CMP[1]	-	VDD	I/O, Hi-Z
102	PB26	EXTINT[12]	-	-	-	-	-	-	SERCOM2 / PAD[0]	SERCOM4 / PAD[1]	-	TCC1 / WO[2]	-	-	-	-	-	-	-	-	VDD	I/O, Hi-Z
103	PB27	EXTINT[13]	-	-	-	-	-	-	SERCOM2 / PAD[1]	SERCOM4 / PAD[0]	-	TCC1 / WO[3]	-	-	-	-	-	-	-	-	VDD	I/O, Hi-Z
104	PB28	EXTINT[14]	-	-	-	-	-	-	SERCOM2 / PAD[2]	SERCOM4 / PAD[2]	-	TCC1 / WO[4]	-	-	-	SCK[1]	-	-	-	-	VDD	I/O, Hi-Z
105	PB29	EXTINT[15]	-	-	-	-	-	-	SERCOM2 / PAD[3]	SERCOM4 / PAD[3]	-	TCC1 / WO[5]	-	-	-	MCK[1]	-	-	-	-	VDD	I/O, Hi-Z
106	VSS	-	-	-	-	-	-	-	-	-	-	-	-	-	-	-	-	-	-	-	-	-
107	VDD	-	-	-	-	-	-	-	-	-	-	-	-	-	-	-	-	-	-	-	-	-
108	PC24	EXTINT[8]	-	-	-	-	-	-	SERCOM0 / PAD[2]	SERCOM2 / PAD[2]	-	-	-	CORTEX_C M4 / TRACEDAT A[3]	-	-	-	-	-	-	VDD	I/O, Hi-Z
109	PC25	EXTINT[9]	-	-	-	-	-	-	SERCOM0 / PAD[3]	SERCOM2 / PAD[3]	-	-	-	CORTEX_C M4 / TRACEDAT A[2]	-	-	-	-	-	-	VDD	I/O, Hi-Z



.....continued

128-Pin TOFP	Port Group:	A	B (2)						C (4)	D (4)	E	F (3)	G	H	I	J	K	L	M	N	Power Rail	Reset State
	Pad Name	EIC	ANAREF	ADC0	ADC1	AC	DAC	PTC	SERCOM	SERCOM	TC	TCC	TCC, PDEC	CAN1, QSPI, USB, CORTEX_GM4	CAN0, SDHC	I2S	PCC	GMAC	GCLK, AC	CCL		
110	PC26	EXTINT[10]	-	-	-	-	-	-	-	-	-	-	-	CORTEX_C M4 / TRACEDAT A[1]	-	-	-	-	-	-	VDD	I/O, Hi-Z
111	PC27	EXTINT[11]	-	-	-	-	-	-	SERCOM1 / PAD[0]	-	-	-	-	CORTEX_C M4 / TRACECLK	-	-	-	-	CORTEX_ M4 / SWO	IN[4]	VDD	I/O, Hi-Z
112	PC28	EXTINT[12]	-	-	-	-	-	-	SERCOM1 / PAD[1]	-	-	-	-	CORTEX_C M4 / TRACEDAT A[0]	-	-	-	-	-	IN[5]	VDD	I/O, Hi-Z
113	PA27	EXTINT[11]	-	-	-	-	-	X18 / Y18	-	-	-	-	-	-	-	-	-	-	GCLK / IQ[1]	-	VDD	I/O, Hi-Z
114	RESET	-	-	-	-	-	-	-	-	-	-	-	-	-	-	-	-	-	-	-	VDD	-
115	VDDCOR E	-	-	-	-	-	-	-	-	-	-	-	-	-	-	-	-	-	-	-	-	-
116	VSS	-	-	-	-	-	-	-	-	-	-	-	-	-	-	-	-	-	-	-	-	-
117	VSW	-	-	-	-	-	-	-	-	-	-	-	-	-	-	-	-	-	-	-	-	-
118	VDD	-	-	-	-	-	-	-	-	-	-	-	-	-	-	-	-	-	-	-	-	-
119	PA30	EXTINT[14]	-	-	-	-	-	X19 / Y19	SERCOM7 / PAD[2]	SERCOM1 / PAD[2]	TC6 / WO[0]	TCC2 / WO[0]	-	CORTEX_C M4 / SWCLK	-	-	-	-	GCLK / IQ[0]	IN[3]	VDD	I, PU
120	PA31	EXTINT[15]	-	-	-	-	-	-	SERCOM7 / PAD[3]	SERCOM1 / PAD[3]	TC6 / WO[1]	TCC2 / WO[1]	-	CORTEX_C M4 / SWDIO	-	-	-	-	-	OUT[1]	VDD	I/O, Hi-Z
121	PB30	EXTINT[14]	-	-	-	-	-	-	SERCOM7 / PAD[0]	SERCOM5 / PAD[1]	TC0 / WO[0]	TCC4 / WO[0]	TCCO / WO[6]	CORTEX_C M4 / SWO	-	-	-	-	-	-	VDD	I/O, Hi-Z
122	PB31	EXTINT[15]	-	-	-	-	-	-	SERCOM7 / PAD[1]	SERCOM5 / PAD[0]	TC0 / WO[1]	TCC4 / WO[1]	TCCO / WO[7]	-	-	-	-	-	-	-	VDD	I/O, Hi-Z
123	PC30	EXTINT[14]	-	-	AIN[12]	-	-	-	-	-	-	-	-	-	-	-	-	-	-	-	VDD	I/O, Hi-Z
124	PC31	EXTINT[15]	-	-	AIN[13]	-	-	-	-	-	-	-	-	-	-	-	-	-	-	-	VDD	I/O, Hi-Z
125	PB00	EXTINT[0]	-	AIN[12]	-	-	-	X30 / Y30	-	SERCOM5 / PAD[2]	TC7 / WO[0]	-	-	-	-	-	-	-	-	IN[1]	VSWOUT	I/O, Hi-Z

.....continued

128-Pin TOFP	Port Group:	A	B (2)						C (4)	D (4)	E	F (3)	G	H	I	J	K	L	M	N	Power Rail	Reset State
	Pad Name	EIC	ANAREF	ADC0	ADC1	AC	DAC	PTC	SERCOM	SERCOM	TC	TCC	TCC, PDEC	CAN1, QSPI, USB, CORTEX_CM4	CAN0, SDHC	I2S	PCC	GMAC	GCLK, AC	CCL		
126	PB01	EXTINT[1]	-	AIN[13]	-	-	-	X31 / Y31	-	SERCOM5 / PAD[3]	TC7 / WO[1]	-	-	-	-	-	-	-	-	IN[2]	VSWOUT	I/O, Hi-Z
127	PB02	EXTINT[2]	-	AIN[14]	-	-	-	X20 / Y20	-	SERCOM5 / PAD[0]	TC6 / WO[0]	TCC2 / WO[2]	-	-	-	-	-	-	-	OUT[0]	VSWOUT	I/O, Hi-Z
128	PB03	EXTINT[3]	-	AIN[15]	-	-	-	X21 / Y21	-	SERCOM5 / PAD[1]	TC6 / WO[1]	-	-	-	-	-	-	-	-	-	VSWOUT	I/O, Hi-Z

**Notes:**

1. The package XCB (128-pin TQFP) has an exposed pad that is an additional ground. This must be soldered to the board's ground plane to provide additional noise immunity and thermal dissipation.
2. All analog pin functions are on the peripheral function B. The peripheral function B must be selected to disable the digital control of the pin. The AC has analog signals on the peripheral function B and digital signals on the peripheral function M.
3. Refer to the [TCC Configuration Summary](#) table for the list of supported features for each peripheral instance.
4. I<sup>2</sup>C is not supported on all SERCOM pins. Refer to the [SERCOM I<sup>2</sup>C Pinout](#) table for the list of supported features for each peripheral instance.
5. The following High-Sink pins have different properties than the regular pins: PA08, PA09, PA12, PA13, PA16, PA17, PA22, PA23, PD08, and PD09.

**Table 4-4. 128-pin TQFP I/O PINMUX (PIC32CX SG60/SG61)**

128-Pin TQFP	Port Group:		A	B (2)					C (5)	D (5)	E	F (4)	G	H	I	J	K	L	M	N	Power Rail	Reset State
	Pad Name	EIC	ANAREF	ADCO	ADC1	AC	DAC	PTC	SERCOM	SERCOM	TC	TCC	TCC, PDEC	CAN1, QSPI, USB, CORTEX_CM4	CAN0, SDHC	I2S	PCC	GMAC	GCLK, AC	CCL		
1	PA00	EXTINT[0]	-	-	-	-	-	-	-	SERCOM1 / PAD[0]	TC2 / WO[0]	-	-	-	-	-	-	-	-	-	VSWOUT	I/O, Hi-Z
2	PA01	EXTINT[1]	-	-	-	-	-	-	-	SERCOM1 / PAD[1]	TC2 / WO[1]	-	-	-	-	-	-	-	-	-	VSWOUT	I/O, Hi-Z
3	PC00	EXTINT[0]	-	-	AIN[10]	-	-	-	-	-	-	-	-	-	-	-	-	-	-	-	VSWOUT	I/O, Hi-Z
4	PC01	EXTINT[1]	-	-	AIN[11]	-	-	-	-	-	-	-	-	-	-	-	-	-	-	-	VSWOUT	I/O, Hi-Z
5	AVSS	-	-	-	-	-	-	-	-	-	-	-	-	-	-	-	-	-	-	-	-	-
6	AVDD	-	-	-	-	-	-	-	-	-	-	-	-	-	-	-	-	-	-	-	-	-
7	PC02	EXTINT[2]	-	-	AIN[4]	-	-	-	-	-	-	-	-	-	-	-	-	-	-	-	AVDD	I/O, Hi-Z
8	PC03	EXTINT[3]	-	-	AIN[5]	-	-	-	-	-	-	-	-	-	-	-	-	-	-	-	AVDD	I/O, Hi-Z
9	PA02	EXTINT[2]	-	AIN[0]	-	-	VOUT[0]	-	-	-	-	-	-	-	-	-	-	-	-	-	AVDD	I/O, Hi-Z
10	PA03	EXTINT[3]	VREFA	AIN[1]	-	-	-	X0 / Y0	-	-	-	-	-	-	-	-	-	-	-	-	AVDD	I/O, Hi-Z
11	PB04	EXTINT[4]	-	-	AIN[6]	-	-	X22 / Y22	-	-	-	-	-	-	-	-	-	-	-	-	AVDD	I/O, Hi-Z
12	PB05	EXTINT[5]	-	-	AIN[7]	-	-	X23 / Y23	-	-	-	-	-	-	-	-	-	-	-	-	AVDD	I/O, Hi-Z
13	PD00	EXTINT[0]	-	-	AIN[14]	-	-	-	-	-	-	-	-	-	-	-	-	-	-	-	AVDD	I/O, Hi-Z
14	AVSS	-	-	-	-	-	-	-	-	-	-	-	-	-	-	-	-	-	-	-	-	-
15	AVDD	-	-	-	-	-	-	-	-	-	-	-	-	-	-	-	-	-	-	-	-	-
16	PD01	EXTINT[1]	-	-	AIN[15]	-	-	-	-	-	-	-	-	-	-	-	-	-	-	-	AVDD	I/O, Hi-Z
17	PB06	EXTINT[6]	-	-	AIN[8]	-	-	X24 / Y24	-	-	-	-	-	-	-	-	-	-	-	-	AVDD	I/O, Hi-Z
18	PB07	EXTINT[7]	-	-	AIN[9]	-	-	X25 / Y25	-	-	-	-	-	-	-	-	-	-	-	-	AVDD	I/O, Hi-Z
19	PB08	EXTINT[8]	-	AIN[2]	AIN[0]	-	-	X1 / Y1	-	SERCOM4 / PAD[0]	TC4 / WO[0]	-	-	-	-	-	-	-	-	IN[8]	AVDD	I/O, Hi-Z
20	PB09	EXTINT[9]	-	AIN[3]	AIN[1]	-	-	X2 / Y2	-	SERCOM4 / PAD[1]	TC4 / WO[1]	-	-	-	-	-	-	-	-	OUT[2]	AVDD	I/O, Hi-Z
21	PA04	EXTINT[4]	VREFB	AIN[4]	-	AIN[0]	-	X3 / Y3	-	SERCOM0 / PAD[0]	TC0 / WO[0]	-	-	-	-	-	-	-	-	IN[0]	AVDD	I/O, Hi-Z

.....continued

128-Pin TQFP	Port Group:		A	B (2)				C (5)		D (5)	E	F (4)	G	H	I	J	K	L	M	N	Power Rail	Reset State
	Pad Name	EIC	ANAREF	ADCO	ADC1	AC	DAC	PTC	SERCOM	SERCOM	TC	TCC	TCC, PDEC	CAN1, QSPI, USB, CORTEX_CM4	CAN0, SDHC	I2S	PCC	GMAC	GCLK, AC	CCL		
22	PA05	EXTINT[5]	-	AIN[5]	-	AIN[1]	VOUT[1]	-	-	SERCOM0 / PAD[1]	TC0 / WO[1]	-	-	-	-	-	-	-	-	IN[1]	AVDD	I/O, Hi-Z
23	PA06	EXTINT[6]	VREFC	AIN[6]	-	AIN[2]	-	X4 / Y4	-	SERCOM0 / PAD[2]	TC1 / WO[0]	-	-	-	SDHC0 / SDCD	-	-	-	-	IN[2]	AVDD	I/O, Hi-Z
24	PA07	EXTINT[7]	-	AIN[7]	-	AIN[3]	-	X5 / Y5	-	SERCOM0 / PAD[3]	TC1 / WO[1]	-	-	-	SDHC0 / SDWP	-	-	-	-	OUT[0]	AVDD	I/O, Hi-Z
25	AVSS	-	-	-	-	-	-	-	-	-	-	-	-	-	-	-	-	-	-	-	-	-
26	AVDD	-	-	-	-	-	-	-	-	-	-	-	-	-	-	-	-	-	-	-	-	-
27 (NC)	PC04 (3)	-	-	-	-	-	-	-	-	-	-	-	-	-	-	-	-	-	-	-	VDD	I/O, Hi-Z
28	PC05	EXTINT[5]	-	-	-	-	-	-	-	SERCOM6 / PAD[1]	-	-	-	-	-	-	-	-	-	-	VDD	I/O, Hi-Z
29	PC06	EXTINT[6]	-	-	-	-	-	-	-	SERCOM6 / PAD[2]	-	-	-	-	SDHC0 / SDCD	-	-	-	-	-	VDD	I/O, Hi-Z
30	PC07	EXTINT[9]	-	-	-	-	-	-	-	SERCOM6 / PAD[3]	-	-	-	-	SDHC0 / SDWP	-	-	-	-	-	VDD	I/O, Hi-Z
31	VSS	-	-	-	-	-	-	-	-	-	-	-	-	-	-	-	-	-	-	-	-	-
32	VDD	-	-	-	-	-	-	-	-	-	-	-	-	-	-	-	-	-	-	-	-	-
33	PA08 (6)	NMI	-	AIN[8]	AIN[2]	-	-	X6 / Y6	SERCOM0 / PAD[0]	SERCOM2 / PAD[1]	TC0 / WO[0]	TCC0 / WO[0]	TCC1 / WO[4]	QSPI / DATA[0]	SDHC0 / SDCMD	MCK[0]	-	-	-	IN[3]	VDD	I/O, Hi-Z
34	PA09 (6)	EXTINT[9]	-	AIN[9]	AIN[3]	-	-	X7 / Y7	SERCOM0 / PAD[1]	SERCOM2 / PAD[0]	TC0 / WO[1]	TCC0 / WO[1]	TCC1 / WO[5]	QSPI / DATA[1]	SDHC0 / SDDAT[0]	FS[0]	-	-	-	IN[4]	VDD	I/O, Hi-Z
35	PA10	EXTINT[10]	-	AIN[10]	-	-	-	X8 / Y8	SERCOM0 / PAD[2]	SERCOM2 / PAD[2]	TC1 / WO[0]	TCC0 / WO[2]	TCC1 / WO[6]	QSPI / DATA[2]	SDHC0 / SDDAT[1]	SCK[0]	-	-	GCLK / IO[4]	IN[5]	VDD	I/O, Hi-Z
36	PA11	EXTINT[11]	-	AIN[11]	-	-	-	X9 / Y9	SERCOM0 / PAD[3]	SERCOM2 / PAD[3]	TC1 / WO[1]	TCC0 / WO[3]	TCC1 / WO[7]	QSPI / DATA[3]	SDHC0 / SDDAT[2]	SDO	-	-	GCLK / IO[5]	OUT[1]	VDD	I/O, Hi-Z
37	VDD	-	-	-	-	-	-	-	-	-	-	-	-	-	-	-	-	-	-	-	-	-
38	VSS	-	-	-	-	-	-	-	-	-	-	-	-	-	-	-	-	-	-	-	-	-
39	PB10	EXTINT[10]	-	-	-	-	-	-	-	SERCOM4 / PAD[2]	TC5 / WO[0]	TCC0 / WO[4]	TCC1 / WO[0]	QSPI / SCK	SDHC0 / SDDAT[3]	SDI	-	-	GCLK / IO[4]	IN[11]	VDD	I/O, Hi-Z
40	PB11	EXTINT[11]	-	-	-	-	-	-	-	SERCOM4 / PAD[3]	TC5 / WO[1]	TCC0 / WO[5]	TCC1 / WO[1]	QSPI / CS	SDHC0 / SDCK	FS[1]	-	-	GCLK / IO[5]	OUT[1]	VDD	I/O, Hi-Z

.....continued

125-Pin TQFP	Port Group:		A	B (2)				C (5)		D (5)	E	F (4)	G	H	I	J	K	L	M	N	Power Rail	Reset State
	Pad Name	EIC	ANAREF	ADCO	ADC1	AC	DAC	PTC	SERCOM	SERCOM	TC	TCC	TCC, PDEC	CAN1, QSPI, USB, CORTEX_CM4	CAN0, SDHC	I2S	PCC	GMAC	GCLK, AC	CCL		
41	PB12	EXTINT[12]	-	-	-	-	-	X26 / Y26	SERCOM4 / PAD[0]	-	TC4 / WO[0]	TCC3 / WO[0]	TCC0 / WO[0]	CAN1 / TX	SDHC0 / SDCD	SCK[1]	-	-	GCLK / IO[6]	-	VDD	I/O, Hi-Z
42	PB13	EXTINT[13]	-	-	-	-	-	X27 / Y27	SERCOM4 / PAD[1]	-	TC4 / WO[1]	TCC3 / WO[1]	TCC0 / WO[1]	CAN1 / RX	SDHC0 / SDWP	MCK[1]	-	-	GCLK / IO[7]	-	VDD	I/O, Hi-Z
43	PB14	EXTINT[14]	-	-	-	-	-	X28 / Y28	SERCOM4 / PAD[2]	-	TC5 / WO[0]	TCC4 / WO[0]	TCC0 / WO[2]	CAN1 / TX	-	-	DATA[8]	GMDC	GCLK / IO[0]	IN[9]	VDD	I/O, Hi-Z
44	PB15	EXTINT[15]	-	-	-	-	-	X29 / Y29	SERCOM4 / PAD[3]	-	TC5 / WO[1]	TCC4 / WO[1]	TCC0 / WO[3]	CAN1 / RX	-	-	DATA[9]	GMDIO	GCLK / IO[1]	IN[10]	VDD	I/O, Hi-Z
45	VSS	-	-	-	-	-	-	-	-	-	-	-	-	-	-	-	-	-	-	-	-	-
46	VDD	-	-	-	-	-	-	-	-	-	-	-	-	-	-	-	-	-	-	-	-	-
47	PD08 (6)	EXTINT[3]	-	-	-	-	-	-	SERCOM7 / PAD[0]	SERCOM6 / PAD[1]	-	TCC0 / WO[1]	-	-	-	-	-	-	-	-	VDD	I/O, Hi-Z
48	PD09 (6)	EXTINT[4]	-	-	-	-	-	-	SERCOM7 / PAD[1]	SERCOM6 / PAD[0]	-	TCC0 / WO[2]	-	-	-	-	-	-	-	-	VDD	I/O, Hi-Z
49	PD10	EXTINT[5]	-	-	-	-	-	-	SERCOM7 / PAD[2]	SERCOM6 / PAD[2]	-	TCC0 / WO[3]	-	-	-	-	-	-	-	-	VDD	I/O, Hi-Z
50	PD11	EXTINT[6]	-	-	-	-	-	-	SERCOM7 / PAD[3]	SERCOM6 / PAD[3]	-	TCC0 / WO[4]	-	-	-	-	-	-	-	-	VDD	I/O, Hi-Z
51	PD12	EXTINT[7]	-	-	-	-	-	-	-	-	-	TCC0 / WO[5]	-	-	-	-	-	-	-	-	VDD	I/O, Hi-Z
52	PC10	EXTINT[10]	-	-	-	-	-	-	SERCOM6 / PAD[2]	SERCOM7 / PAD[2]	-	TCC0 / WO[0]	TCC1 / WO[4]	-	-	-	-	-	-	-	VDD	I/O, Hi-Z
53	VSS	-	-	-	-	-	-	-	-	-	-	-	-	-	-	-	-	-	-	-	-	-
54	VDD	-	-	-	-	-	-	-	-	-	-	-	-	-	-	-	-	-	-	-	-	-
55	PC11	EXTINT[11]	-	-	-	-	-	-	SERCOM6 / PAD[3]	SERCOM7 / PAD[3]	-	TCC0 / WO[1]	TCC1 / WO[5]	-	-	-	-	GMDC	-	-	VDD	I/O, Hi-Z
56	PC12	EXTINT[12]	-	-	-	-	-	-	SERCOM7 / PAD[0]	SERCOM6 / PAD[1]	-	TCC0 / WO[2]	TCC1 / WO[6]	-	-	-	DATA[10]	GMDIO	-	-	VDD	I/O, Hi-Z
57	PC13	EXTINT[13]	-	-	-	-	-	-	SERCOM7 / PAD[1]	SERCOM6 / PAD[0]	-	TCC0 / WO[3]	TCC1 / WO[7]	-	-	-	DATA[11]	-	-	-	VDD	I/O, Hi-Z
58	PC14	EXTINT[14]	-	-	-	-	-	-	SERCOM7 / PAD[2]	SERCOM6 / PAD[2]	-	TCC0 / WO[4]	TCC1 / WO[0]	-	-	-	DATA[12]	GRX[3]	-	-	VDD	I/O, Hi-Z

.....continued

128-Pin TQFP	Port Group:		A	B (2)					C (5)	D (5)	E	F (4)	G	H	I	J	K	L	M	N	Power Rail	Reset State
	Pad Name	EIC	ANAREF	ADCO	ADC1	AC	DAC	PTC	SERCOM	SERCOM	TC	TCC	TCC, PDEC	CAN1, QSPI, USB, CORTEX_CM4	CAN0, SDHC	I2S	PCC	GMAC	GCLK, AC	CCL		
59	PC15	EXTINT[15]	-	-	-	-	-	-	SERCOM7 / PAD[3]	SERCOM6 / PAD[3]	-	TCC0 / WO[5]	TCC1 / WO[1]	-	-	-	DATA[13]	GRX[2]	-	-	VDD	I/O, Hi-Z
60	PA12 (6)	EXTINT[12]	-	-	-	-	-	-	SERCOM2 / PAD[0]	SERCOM4 / PAD[1]	TC2 / WO[0]	TCC0 / WO[6]	TCC1 / WO[2]	-	SDHC0 / SDCD	-	DEN1	GRX[1]	AC / CMP[0]	-	VDD	I/O, Hi-Z
61	PA13 (6)	EXTINT[13]	-	-	-	-	-	-	SERCOM2 / PAD[1]	SERCOM4 / PAD[0]	TC2 / WO[1]	TCC0 / WO[7]	TCC1 / WO[3]	-	SDHC0 / SDWP	-	DEN2	GRX[0]	AC / CMP[1]	-	VDD	I/O, Hi-Z
62	PA14	EXTINT[14]	-	-	-	-	-	-	SERCOM2 / PAD[2]	SERCOM4 / PAD[2]	TC3 / WO[0]	TCC2 / WO[0]	TCC1 / WO[2]	-	-	-	CLK	GTXCK	GCLK / IO[0]	-	VDD	I/O, Hi-Z
63	PA15	EXTINT[15]	-	-	-	-	-	-	SERCOM2 / PAD[3]	SERCOM4 / PAD[3]	TC3 / WO[1]	TCC2 / WO[1]	TCC1 / WO[3]	-	-	-	-	GRXER	GCLK / IO[1]	-	VDD	I/O, Hi-Z
64	VSS	-	-	-	-	-	-	-	-	-	-	-	-	-	-	-	-	-	-	-	-	-
65	VDD	-	-	-	-	-	-	-	-	-	-	-	-	-	-	-	-	-	-	-	-	-
66	PA16 (6)	EXTINT[0]	-	-	-	-	-	X10 / Y10	SERCOM1 / PAD[0]	SERCOM3 / PAD[1]	TC2 / WO[0]	TCC1 / WO[0]	TCC0 / WO[4]	-	-	-	DATA[0]	GCRS	GCLK / IO[2]	IN[0]	VDD	I/O, Hi-Z
67	PA17 (6)	EXTINT[1]	-	-	-	-	-	X11 / Y11	SERCOM1 / PAD[1]	SERCOM3 / PAD[0]	TC2 / WO[1]	TCC1 / WO[1]	TCC0 / WO[5]	-	-	-	DATA[1]	GTXEN	GCLK / IO[3]	IN[1]	VDD	I/O, Hi-Z
68	PA18	EXTINT[2]	-	-	-	-	-	X12 / Y12	SERCOM1 / PAD[2]	SERCOM3 / PAD[2]	TC3 / WO[0]	TCC1 / WO[2]	TCC0 / WO[6]	-	-	-	DATA[2]	GTX[0]	AC / CMP[0]	IN[2]	VDD	I/O, Hi-Z
69	PA19	EXTINT[3]	-	-	-	-	-	X13 / Y13	SERCOM1 / PAD[3]	SERCOM3 / PAD[3]	TC3 / WO[1]	TCC1 / WO[3]	TCC0 / WO[7]	-	-	-	DATA[3]	GTX[1]	AC / CMP[1]	OUT[0]	VDD	I/O, Hi-Z
70	PC16	EXTINT[0]	-	-	-	-	-	-	SERCOM6 / PAD[0]	SERCOM0 / PAD[1]	-	TCC0 / WO[0]	PDEC / QDI[0]	-	-	-	-	GTX[2]	-	-	VDD	I/O, Hi-Z
71	PC17	EXTINT[1]	-	-	-	-	-	-	SERCOM6 / PAD[1]	SERCOM0 / PAD[0]	-	TCC0 / WO[1]	PDEC / QDI[1]	-	-	-	-	GTX[3]	-	-	VDD	I/O, Hi-Z
72	PC18	EXTINT[2]	-	-	-	-	-	-	SERCOM6 / PAD[2]	SERCOM0 / PAD[2]	-	TCC0 / WO[2]	PDEC / QDI[2]	-	-	-	-	GRXCK	-	-	VDD	I/O, Hi-Z
73	PC19	EXTINT[3]	-	-	-	-	-	-	SERCOM6 / PAD[3]	SERCOM0 / PAD[3]	-	TCC0 / WO[3]	-	-	-	-	-	GTXER	-	-	VDD	I/O, Hi-Z
74	PC20	EXTINT[4]	-	-	-	-	-	-	-	-	-	TCC0 / WO[4]	-	SDHC1 / SDCD	-	-	-	GRXDV	-	IN[9]	VDD	I/O, Hi-Z
75	PC21	EXTINT[5]	-	-	-	-	-	-	-	-	-	TCC0 / WO[5]	-	SDHC1 / SDWP	-	-	-	GCOL	-	IN[10]	VDD	I/O, Hi-Z

.....continued

128-Pin TQFP	Port Group:		A	B (2)				C (5)	D (5)	E	F (4)	G	H	I	J	K	L	M	N	Power Rail	Reset State	
	Pad Name	EIC	ANAREF	ADCO	ADC1	AC	DAC	PTC	SERCOM	SERCOM	TC	TCC	TCC, PDEC	CAN1, QSPI, USB, CORTEX_CM4	CAN0, SDHC	I2S	PCC	GMAC	GCLK, AC			CCL
76	PC22	EXTINT[6]	-	-	-	-	-	-	SERCOM1 / PAD[0]	SERCOM3 / PAD[1]	-	TCC0 / WO[6]	-	-	-	-	GMDC	-	-	VDD	I/O, Hi-Z	
77	PC23	EXTINT[7]	-	-	-	-	-	-	SERCOM1 / PAD[1]	SERCOM3 / PAD[0]	-	TCC0 / WO[7]	-	-	-	-	GMDIO	-	-	VDD	I/O, Hi-Z	
78	VSS	-	-	-	-	-	-	-	-	-	-	-	-	-	-	-	-	-	-	-	-	
79	VDD	-	-	-	-	-	-	-	-	-	-	-	-	-	-	-	-	-	-	-	-	
80	PD20	EXTINT[10]	-	-	-	-	-	-	SERCOM1 / PAD[2]	SERCOM3 / PAD[2]	-	TCC1 / WO[0]	-	-	SDHC1 / SDCD	-	-	-	-	VDD	I/O, Hi-Z	
81	PD21	EXTINT[11]	-	-	-	-	-	-	SERCOM1 / PAD[3]	SERCOM3 / PAD[3]	-	TCC1 / WO[1]	-	-	SDHC1 / SDWP	-	-	-	-	VDD	I/O, Hi-Z	
82	PB16	EXTINT[0]	-	-	-	-	-	-	SERCOM5 / PAD[0]	-	TC6 / WO[0]	TCC3 / WO[0]	TCC0 / WO[4]	-	SDHC1 / SDCD	SCK[0]	-	-	GCLK / IO[2]	IN[11]	VDD	I/O, Hi-Z
83	PB17	EXTINT[1]	-	-	-	-	-	-	SERCOM5 / PAD[1]	-	TC6 / WO[1]	TCC3 / WO[1]	TCC0 / WO[5]	-	SDHC1 / SDWP	MCK[0]	-	-	GCLK / IO[3]	OUT[3]	VDD	I/O, Hi-Z
84	PB18	EXTINT[2]	-	-	-	-	-	-	SERCOM5 / PAD[2]	SERCOM7 / PAD[2]	-	TCC1 / WO[0]	PDEC / QDI[0]	-	SDHC1 / SDDAT[0]	-	-	-	GCLK / IO[4]	-	VDD	I/O, Hi-Z
85	PB19	EXTINT[3]	-	-	-	-	-	-	SERCOM5 / PAD[3]	SERCOM7 / PAD[3]	-	TCC1 / WO[1]	PDEC / QDI[1]	-	SDHC1 / SDDAT[1]	-	-	-	GCLK / IO[5]	-	VDD	I/O, Hi-Z
86	PB20	EXTINT[4]	-	-	-	-	-	-	SERCOM3 / PAD[0]	SERCOM7 / PAD[1]	-	TCC1 / WO[2]	PDEC / QDI[2]	-	SDHC1 / SDDAT[2]	-	-	-	GCLK / IO[6]	-	VDD	I/O, Hi-Z
87	PB21	EXTINT[5]	-	-	-	-	-	-	SERCOM3 / PAD[1]	SERCOM7 / PAD[0]	-	TCC1 / WO[3]	-	-	SDHC1 / SDDAT[3]	-	-	-	GCLK / IO[7]	-	VDD	I/O, Hi-Z
88	PA20	EXTINT[4]	-	-	-	-	-	X14 / Y14	SERCOM5 / PAD[2]	SERCOM3 / PAD[2]	TC7 / WO[0]	TCC1 / WO[4]	TCC0 / WO[0]	-	SDHC1 / SDCMD	FS[0]	DATA[4]	GMDC	-	-	VDD	I/O, Hi-Z
89	PA21	EXTINT[5]	-	-	-	-	-	X15 / Y15	SERCOM5 / PAD[3]	SERCOM3 / PAD[3]	TC7 / WO[1]	TCC1 / WO[5]	TCC0 / WO[1]	-	SDHC1 / SDCK	SDO	DATA[5]	GMDIO	-	-	VDD	I/O, Hi-Z
90	VSS	-	-	-	-	-	-	-	-	-	-	-	-	-	-	-	-	-	-	-	-	-
91	VDD	-	-	-	-	-	-	-	-	-	-	-	-	-	-	-	-	-	-	-	-	-
92	PA22 (6)	EXTINT[6]	-	-	-	-	-	X16 / Y16	SERCOM3 / PAD[0]	SERCOM5 / PAD[1]	TC4 / WO[0]	TCC1 / WO[6]	TCC0 / WO[2]	-	CAN0 / TX	SDI	DATA[6]	-	-	IN[6]	VDD	I/O, Hi-Z
93	PA23 (6)	EXTINT[7]	-	-	-	-	-	X17 / Y17	SERCOM3 / PAD[1]	SERCOM5 / PAD[0]	TC4 / WO[1]	TCC1 / WO[7]	TCC0 / WO[3]	USB / SOF_1KHZ	CAN0 / RX	FS[1]	DATA[7]	-	-	IN[7]	VDD	I/O, Hi-Z



.....continued

128-Pin TQFP	Port Group:		A	B (2)				C (5)	D (5)	E	F (4)	G	H	I	J	K	L	M	N	Power Rail	Reset State
	Pad Name	EIC	ANAREF	ADCO	ADC1	AC	DAC	PTC	SERCOM	SERCOM	TC	TCC	TCC, PDEC	CAN1, QSPI, USB, CORTEX_CM4	CAN0, SDHC	I2S	PCC	GMAC	GCLK, AC		
94	PA24	EXTINT[8]	-	-	-	-	-	SERCOM3 / PAD[2]	SERCOM5 / PAD[2]	TC5 / WO[0]	TCC2 / WO[2]	PDEC / QDI[0]	USB / DM	CAN0 / TX	-	-	-	-	IN[8]	VDD	I, PD
95	PA25	EXTINT[9]	-	-	-	-	-	SERCOM3 / PAD[3]	SERCOM5 / PAD[3]	TC5 / WO[1]	-	PDEC / QDI[1]	USB / DP	CAN0 / RX	-	-	-	-	OUT[2]	VDD	I, PD
96	VSS	-	-	-	-	-	-	-	-	-	-	-	-	-	-	-	-	-	-	-	-
97	VDD	-	-	-	-	-	-	-	-	-	-	-	-	-	-	-	-	-	-	-	-
98	PB22	EXTINT[6]	-	-	-	-	-	SERCOM1 / PAD[2]	SERCOM5 / PAD[2]	TC7 / WO[0]	-	PDEC / QDI[2]	USB / SOF_1KHZ	-	-	-	-	GCLK / IO[0]	IN[0]	VDD	I/O, Hi-Z
99	PB23	EXTINT[7]	-	-	-	-	-	SERCOM1 / PAD[3]	SERCOM5 / PAD[3]	TC7 / WO[1]	-	PDEC / QDI[0]	-	-	-	-	-	GCLK / IO[1]	OUT[0]	VDD	I/O, Hi-Z
100	PB24	EXTINT[8]	-	-	-	-	-	SERCOM0 / PAD[0]	SERCOM2 / PAD[1]	-	-	PDEC / QDI[1]	-	-	-	-	-	AC / CMP[0]	-	VDD	I/O, Hi-Z
101	PB25	EXTINT[9]	-	-	-	-	-	SERCOM0 / PAD[1]	SERCOM2 / PAD[0]	-	-	PDEC / QDI[2]	-	-	-	-	-	AC / CMP[1]	-	VDD	I/O, Hi-Z
102 (NC)	PB26 (3)	-	-	-	-	-	-	SERCOM2 / PAD[0]	-	-	-	-	-	-	-	-	-	-	-	VDD	I/O, Hi-Z
103 (NC)	PB27 (3)	-	-	-	-	-	-	SERCOM2 / PAD[1]	-	-	-	-	-	-	-	-	-	-	-	VDD	I/O, Hi-Z
104 (NC)	PB28 (3)	-	-	-	-	-	-	SERCOM2 / PAD[2]	-	-	-	-	-	-	-	-	-	-	-	VDD	I/O, Hi-Z
105 (NC)	PB29 (3)	-	-	-	-	-	-	-	-	-	-	-	-	-	-	-	-	-	-	VDD	I/O, Hi-Z
106	VSS	-	-	-	-	-	-	-	-	-	-	-	-	-	-	-	-	-	-	-	-
107	VDD	-	-	-	-	-	-	-	-	-	-	-	-	-	-	-	-	-	-	-	-
108	PC24	EXTINT[8]	-	-	-	-	-	SERCOM0 / PAD[2]	SERCOM2 / PAD[2]	-	-	-	CORTEX_C M4 / TRACEDAT A[3]	-	-	-	-	-	-	VDD	I/O, Hi-Z
109	PC25	EXTINT[9]	-	-	-	-	-	SERCOM0 / PAD[3]	SERCOM2 / PAD[3]	-	-	-	CORTEX_C M4 / TRACEDAT A[2]	-	-	-	-	-	-	VDD	I/O, Hi-Z

.....continued

128-Pin TQFP	Port Group:																Power Rail	Reset State				
	Pad Name	A	B (2)						C (5)		D (5)	E	F (4)		G	H			I	J	K	L
	EIC	ANAREF	ADCO	ADC1	AC	DAC	PTC	SERCOM	SERCOM	TC	TCC	TCC, PDEC	CAN1, QSPI, USB, CORTEX_CM4	CAN0, SDHC	I2S	PCC	GMAC	GCLK, AC	CCL			
110	PC26	EXTINT[10]	-	-	-	-	-	-	-	-	-	-	CORTEX_C M4 / TRACEDAT A[1]	-	-	-	-	-	-	-	VDD	I/O, Hi-Z
111	PC27	EXTINT[11]	-	-	-	-	-	SERCOM1 / PAD[0]	-	-	-	-	CORTEX_C M4 / TRACECLK	-	-	-	-	CORTEX_ M4 / SWO	IN[4]	-	VDD	I/O, Hi-Z
112	PC28	EXTINT[12]	-	-	-	-	-	SERCOM1 / PAD[1]	-	-	-	-	CORTEX_C M4 / TRACEDAT A[0]	-	-	-	-	-	IN[5]	-	VDD	I/O, Hi-Z
113	PA27	EXTINT[11]	-	-	-	-	-	X18 / Y18	-	-	-	-	-	-	-	-	-	GCLK / IO[1]	-	-	VDD	I/O, Hi-Z
114	RESET	-	-	-	-	-	-	-	-	-	-	-	-	-	-	-	-	-	-	-	VDD	-
115	VDDCOR E	-	-	-	-	-	-	-	-	-	-	-	-	-	-	-	-	-	-	-	-	-
116	VSS	-	-	-	-	-	-	-	-	-	-	-	-	-	-	-	-	-	-	-	-	-
117	VSW	-	-	-	-	-	-	-	-	-	-	-	-	-	-	-	-	-	-	-	-	-
118	VDD	-	-	-	-	-	-	-	-	-	-	-	-	-	-	-	-	-	-	-	-	-
119	PA30	EXTINT[14]	-	-	-	-	-	X19 / Y19	SERCOM7 / PAD[2]	SERCOM1 / PAD[2]	TC6 / WO[0]	TCC2 / WO[0]	-	CORTEX_C M4 / SWCLK	-	-	-	GCLK / IO[0]	IN[3]	-	VDD	I, PU
120	PA31	EXTINT[15]	-	-	-	-	-	-	SERCOM7 / PAD[3]	SERCOM1 / PAD[3]	TC6 / WO[1]	TCC2 / WO[1]	-	CORTEX_C M4 / SWDIO	-	-	-	-	OUT[1]	-	VDD	I/O, Hi-Z
121	PB30	EXTINT[14]	-	-	-	-	-	-	SERCOM7 / PAD[0]	SERCOM5 / PAD[1]	TC0 / WO[0]	TCC4 / WO[0]	TCC0 / WO[6]	CORTEX_C M4 / SWO	-	-	-	-	-	-	VDD	I/O, Hi-Z
122	PB31	EXTINT[15]	-	-	-	-	-	-	SERCOM7 / PAD[1]	SERCOM5 / PAD[0]	TC0 / WO[1]	TCC4 / WO[1]	TCC0 / WO[7]	-	-	-	-	-	-	-	VDD	I/O, Hi-Z
123	PC30	EXTINT[14]	-	-	AIN[12]	-	-	-	-	-	-	-	-	-	-	-	-	-	-	-	VDD	I/O, Hi-Z
124	PC31	EXTINT[15]	-	-	AIN[13]	-	-	-	-	-	-	-	-	-	-	-	-	-	-	-	VDD	I/O, Hi-Z
125	PB00	EXTINT[0]	-	AIN[12]	-	-	-	X30 / Y30	-	SERCOM5 / PAD[2]	TC7 / WO[0]	-	-	-	-	-	-	-	IN[1]	-	VSWOUT	I/O, Hi-Z

.....continued

128-Pin TQFP	Port Group:		A	B (2)				C (5)	D (5)	E	F (4)	G	H	I	J	K	L	M	N	Power Rail	Reset State
	Pad Name	EIC	ANAREF	ADCO	ADC1	AC	DAC	PTC	SERCOM	SERCOM	TC	TCC	TCC, PDEC	CAN1, QSPI, USB, CORTEX_CM4	CAN0, SDHC	I2S	PCC	GMAC	GCLK, AC		
126	PB01	EXTINT[1]	-	AIN[13]	-	-	-	X31 / Y31	-	SERCOM5 / PAD[3]	TC7 / WO[1]	-	-	-	-	-	-	-	IN[2]	VSWOUT	I/O, Hi-Z
127	PB02	EXTINT[2]	-	AIN[14]	-	-	-	X20 / Y20	-	SERCOM5 / PAD[0]	TC6 / WO[0]	TCC2 / WO[2]	-	-	-	-	-	-	OUT[0]	VSWOUT	I/O, Hi-Z
128	PB03	EXTINT[3]	-	AIN[15]	-	-	-	X21 / Y21	-	SERCOM5 / PAD[1]	TC6 / WO[1]	-	-	-	-	-	-	-	-	VSWOUT	I/O, Hi-Z

**Notes:**

1. The package XCB (128-pin TQFP) has an exposed pad that is an additional ground. This must be soldered to the board's ground plane to provide additional noise immunity and thermal dissipation.
2. All analog pin functions are on the peripheral function B. The peripheral function B must be selected to disable the digital control of the pin. The AC has analog signals on the peripheral function B and digital signals on the peripheral function M.
3. Five I/O pins (PB26, PB27, PB28, PB29 and PC04) are not connected as reserved for the HSM interconnection.
4. Refer to the [TCC Configuration Summary](#) table for the list of supported features for each peripheral instance.
5. I<sup>2</sup>C is not supported on all SERCOM pins. Refer to the [SERCOM I<sup>2</sup>C Pinout](#) table for the list of supported features for each peripheral instance.
6. The following High-Sink pins have different properties than the regular pins: PA08, PA09, PA12, PA13, PA16, PA17, PA22, PA23, PD08, and PD09.

## 4.4 IOSET Configurations

**CAUTION** I/Os for SERCOM, GMAC, I<sup>2</sup>S, TC, TCC and PDEC peripherals are grouped into I/O sets, listed in their 'IOSET' table. For these peripherals, it is mandatory to use I/Os that belong to the same I/O set. The peripheral's timings are not guaranteed when I/Os from different I/O sets are mixed.

### 4.4.1 SERCOM IOSET Configurations

The following tables lists each IOSET Pins for each SERCOM instance.

**Table 4-5.** SERCOM0 IOSET Configuration

SERCOM Signal	IOSET 1 Pins	IOSET 2 Pins	IOSET 3 Pins	IOSET 4 Pins
PAD0	PA08	PB24	PA04	PC17
PAD1	PA09	PB25	PA05	PC16
PAD2	PA10	PC24	PA06	PC18
PAD3	PA11	PC25	PA07	PC19

**Table 4-6.** SERCOM1 IOSET Configuration

SERCOM Signal	IOSET 1 Pins	IOSET 2 Pins	IOSET 3 Pins	IOSET 4 Pins
PAD0	PA16	PC22	PC27	PA00
PAD1	PA17	PC23	PC28	PA01
PAD2	PA18	PD20	PB22	PA30
PAD3	PA19	PD21	PB23	PA31

**Table 4-7.** SERCOM2 IOSET Configuration

SERCOM Signal	IOSET 1 Pins	IOSET 2 Pins	IOSET 3 Pins	IOSET 4 Pins
PAD0	PA12	PB26	PA09	PB25
PAD1	PA13	PB27	PA08	PB24
PAD2	PA14	PB28	PA10	PC24
PAD3	PA15	PB29	PA11	PC25

**Table 4-8.** SERCOM3 IOSET Configuration

SERCOM Signal	IOSET 1 Pins	IOSET 2 Pins	IOSET 3 Pins	IOSET 4 Pins
PAD0	PA22	PB20	PA17	PC23
PAD1	PA23	PB21	PA16	PC22
PAD2	PA24	PA20	PA18	PD20
PAD3	PA25	PA21	PA19	PD21

**Table 4-9.** SERCOM4 IOSET Configuration

SERCOM Signal	IOSET 1 Pins	IOSET 2 Pins	IOSET 3 Pins	IOSET 4 Pins
PAD0	PB12	PB08	PA13	PB27
PAD1	PB13	PB09	PA12	PB26
PAD2	PB14	PB10	PA14	PB28
PAD3	PB15	PB11	PA15	PB29

**Table 4-10.** SERCOM5 IOSET Configuration

SERCOM Signal	IOSET 1 Pins	IOSET 2 Pins	IOSET 3 Pins	IOSET 4 Pins	IOSET 5 Pins	IOSET 6 Pins
PAD0	PB16	PA23	PA23	PA23	PB31	PB02

.....continued

SERCOM Signal	IOSET 1 Pins	IOSET 2 Pins	IOSET 3 Pins	IOSET 4 Pins	IOSET 5 Pins	IOSET 6 Pins
PAD1	PB17	PA22	PA22	PA22	PB30	PB03
PAD2	PB18	PA20	PA24	PB22	PB00	PB00
PAD3	PB19	PA21	PA25	PB23	PB01	PB01

**Table 4-11. SERCOM6 IOSET Configuration**

SERCOM Signal	IOSET 1 Pins	IOSET 2 Pins	IOSET 3 Pins	IOSET 4 Pins	IOSET 5 Pins
PAD0	PC16	PC04	PD09	PC13	PC13
PAD1	PC17	PC05	PD08	PC12	PC12
PAD2	PC18	PC06	PD10	PC14	PC10
PAD3	PC19	PC07	PD11	PC15	PC11

**Table 4-12. SERCOM7 IOSET Configuration**

SERCOM Signal	IOSET 1 Pins	IOSET 2 Pins	IOSET 3 Pins	IOSET 4 Pins	IOSET 5 Pins
PAD0	PC12	PD08	PC12	PB21	PB30
PAD1	PC13	PD09	PC13	PB20	PB31
PAD2	PC14	PD10	PC10	PB18	PA30
PAD3	PC15	PD11	PC11	PB19	PA31

#### 4.4.2 GMAC IOSET Configurations

The following tables lists each IOSET pins for GMDIO and GMDC signals. All other GMAC signals can be used with all available IOSET configurations.

**Table 4-13. GMAC IOSET Configuration**

GMAC Signal	IOSET 1 Pins	IOSET 2 Pins	IOSET 3 Pins	IOSET 4 Pins
GMDC	PB14	PC11	PC22	PA20
GMDIO	PB15	PC12	PC23	PA21

#### 4.4.3 I<sup>2</sup>S IOSET Configurations

The following tables lists each IOSET Pins for I<sup>2</sup>S instance.

**Table 4-14. I<sup>2</sup>S IOSET Configuration**

I <sup>2</sup> S Signal	IOSET 1 Pins	IOSET 2 Pins
MCK0	PA08	PB17
FS0	PA09	PA20
SCK0	PA10	PB16
SDO	PA11	PA21
SDI	PB10	PA22
FS1	PB11	PA23
SCK1	PB12	PB28
MCK1	PB13	PB29

#### 4.4.4 TC IOSET Configurations

The following tables lists each IOSET Pins for each TC instance.

**Table 4-15. TC0 IOSET Configuration**

TC Signal	IOSET 1 Pins	IOSET 2 Pins	IOSET 3 Pins
WO0	PA04	PA08	PB30
WO1	PA05	PA09	PB31

**Table 4-16. TC1 IOSET Configuration**

TC Signal	IOSET 1 Pins	IOSET 2 Pins
WO0	PA06	PA10
WO1	PA07	PA11

**Table 4-17. TC2 IOSET Configuration**

TC Signal	IOSET 1 Pins	IOSET 2 Pins	IOSET 3 Pins
WO0	PA00	PA12	PA16
WO1	PA01	PA13	PA17

**Table 4-18. TC3 IOSET Configuration**

TC Signal	IOSET 1 Pins	IOSET 2 Pins
WO0	PA14	PA18
WO1	PA15	PA19

**Table 4-19. TC4 IOSET Configuration**

TC Signal	IOSET 1 Pins	IOSET 2 Pins	IOSET 3 Pins
WO0	PB08	PB12	PA22
WO1	PB09	PB13	PA23

**Table 4-20. TC5 IOSET Configuration**

TC Signal	IOSET 1 Pins	IOSET 2 Pins	IOSET 3 Pins
WO0	PB10	PB14	PA24
WO1	PB11	PB15	PA25

**Table 4-21. TC6 IOSET Configuration**

TC Signal	IOSET 1 Pins	IOSET 2 Pins	IOSET 3 Pins
WO0	PB16	PA30	PB02
WO1	PB03	PB17	PA31

**Table 4-22. TC7 IOSET Configuration**

TC Signal	IOSET 1 Pins	IOSET 2 Pins	IOSET 3 Pins
WO0	PA20	PB22	PB00
WO1	PA21	PB23	PB01

#### 4.4.5 TCC IOSET Configurations

The following tables lists each IOSET Pins for each TCC instance.

**Table 4-23. TCC0 IOSET Configuration**

TCC Signal	IOSET 1 Pins	IOSET 2 Pins	IOSET 3 Pins	IOSET 4 Pins	IOSET 5 Pins	IOSET 6 Pins
WO0	PA08	PC04	PC10	PC16	PB12	PA20
WO1	PA09	PD08	PC11	PC17	PB13	PA21
WO2	PA10	PD09	PC12	PC18	PB14	PA22
WO3	PA11	PD10	PC13	PC19	PB15	PA23
WO4	PB10	PD11	PC14	PC20	PA16	PB16
WO5	PB11	PD12	PC15	PC21	PA17	PB17
WO6	PA12	PC22	PA18	PB30	N/A <sup>(1)</sup>	N/A <sup>(1)</sup>
WO7	PA13	PC23	PA19	PB31	N/A <sup>(1)</sup>	N/A <sup>(1)</sup>

**Note:** 1. The signal is available, but the edges are not aligned with respect to the other signals as specified.

**Table 4-24. TCC1 IOSET Configuration**

TCC Signal	IOSET 1 Pins	IOSET 2 Pins	IOSET 3 Pins	IOSET 4 Pins	IOSET 5 Pins
WO0	PA16	PD20	PB18	PB10	PC14
WO1	PA17	PD21	PB19	PB11	PC15
WO2	PA18	PB20	PB26	PA12	PA14
WO3	PA19	PB21	PB27	PA13	PA15
WO4	PA20	PB28	PA08	PC10	N/A <sup>(1)</sup>
WO5	PA21	PB29	PA09	PC11	N/A <sup>(1)</sup>
WO6	PA22	PA10	PC12	N/A <sup>(1)</sup>	N/A <sup>(1)</sup>
WO7	PA23	PA11	PC13	N/A <sup>(1)</sup>	N/A <sup>(1)</sup>

**Note:** 1. The signal is available, but the edges are not aligned with respect to. the other signals as specified.

**Table 4-25. TCC2 IO SET Configuration**

TCC Signal	IOSET 1 Pins	IOSET 2 Pins
WO0	PA14	PA30
WO1	PA15	PA31
WO2	PA24	PB02

**Table 4-26. TCC3 IO SET Configuration**

TCC Signal	IOSET 1 Pins	IOSET 2 Pins
WO0	PB12	PB16
WO1	PB13	PB17

**Table 4-27. TCC4 IO SET Configuration**

TCC Signal	IOSET 1 Pins	IOSET 2 Pins
WO0	PB14	PB30
WO1	PB15	PB31

#### 4.4.6 PDEC IOSET Configurations

The following tables lists each IOSET Pins for PDEC instance.

**Table 4-28. PDEC IOSET Configuration**

PDEC Signal	IOSET 1 Pins	IOSET 2 Pins	IOSET 3 Pins	IOSET 4 Pins
QDI[0]	PC16	PB18	PA24	PB23
QDI[1]	PC17	PB19	PA25	PB24
QDI[2]	PC18	PB20	PB22	PB25

#### 4.5 Oscillator Pinout

The oscillators are not mapped to the normal PORT functions and their multiplexing is controlled by registers in the Oscillators Controller (OSCCTRL) and in the 32K Oscillators Controller (OSC32KCTRL).

**Table 4-29. Oscillator Pinout**

Oscillator	Supply	Signal	I/O pin
XOSC0	VDD	XIN	PA14
		XOUT	PA15
XOSC1	VDD	XIN	PB22
		XOUT	PB23



.....continued

Oscillator	Supply	Signal	I/O pin
XOSC32K	VSWOUT	XIN32	PA00
		XOUT32	PA01

**Note:** To guarantee the XOSC32K behavior in crystal mode, PC00 must be static.

**Table 4-30.** XOSC32K Jitter Minimization

Package Pin Count	Steady Signal Recommended
128	PB00, PB01, PB02, PB03, PC00, PC01
100	PB00, PB01, PB02, PB03, PC00, PC01
64	PB00, PB01, PB02, PB03

## 4.6 Supply Controller Pinout

The outputs of the Supply Controller (SUPC) are not mapped to the normal PORT functions. They are controlled by registers in the SUPC.

**Table 4-31.** SUPC Pinout

Signal	I/O pin
OUT0	PB01
OUT1	PB02



**Important:** If the RTC is enabled to use the pins shared with the SUPC, the RTC will have higher priority.

## 4.7 RTC Pinout

The pins used for Tamper Detection by the Real Time Counter (RTC) are not mapped to the normal PORT functions. These pins and their multiplexing is controlled by register settings of the RTC. If many pins of the tamper detection feature is not used by the RTC, then the pin could be used for other I/O functions, by ensuring the corresponding TAMPCTRL.INACT function is disabled.

**Table 4-32.** RTC Pinout

RTC Signal	I/O Pin
IN0	PB00
IN1	PB02
IN2	PA02
IN3	PC00
IN4	PC01
OUT	PB01



**Important:** If Supply Controller (SUPC) and RTC are configured to drive pin PB01 or pin PB02, then the RTC has priority.

## 4.8 Backup I/O Pins

These pins can be used when operating in Backup mode and are not mapped to the normal PORT functions, hence these pins are controlled by the related peripheral registers.

**Table 4-33.** Backup I/O Pins

Peripheral	Signal	I/O Pin
XOSC32K	XIN32	PA00
XOSC32K	XOUT32	PA01
RTC	IN0	PB00
SUPC (or RTC)	OUT0 (or OUT)	PB01
SUPC (or RTC)	OUT1 (or IN1)	PB02
SUPC	VBAT	PB03
RTC	IN3	PC00
RTC	IN4	PC01



**Important:** These I/Os have specific electrical characteristics. Refer to [I/O Pin Electrical Specifications](#).

## 5. Signal Descriptions List

The following table provides details on signal names classified by peripherals.

**Table 5-1.** Signal Descriptions List

Signal Name	Function	Type
<b>Device Service Unit (DSU)</b>		
SWCLK	Serial Wire Clock	Digital Input
SWDIO	Serial Wire Bidirectional Data Pin	Digital I/O
RESET	External Reset Pin (Active Level: LOW)	Digital Input
<b>Trace Port Interface Unit (TPIU)</b>		
TRACEDATA[3:0]	Trace Data Output	Digital Output
TRACECLK	Trace Clock	Digital Output
SWO	Serial Wire Output	Digital Output
<b>Analog Comparators (AC)</b>		
CMP[1:0]	AC Comparator Outputs	Digital Output
AIN[3:0]	AC Comparator Inputs	Analog Input
<b>Analog Digital Converter (ADC)</b>		
AIN[15:0]	ADC Input Channels	Analog Input
VREFA	ADC External Reference Voltage A	Analog Input
VREFB	ADC External Reference Voltage B	Analog Input
VREFC	ADC External Reference Voltage C	Analog Input
<b>Peripheral Touch Controller (PTC)</b>		
XY[31:0]	X-lines and Y-lines	Digital Output (X-line) /Analog I/O (Y-line)
<b>Digital Analog Converter (DAC)</b>		
VOUT[1:0]	DAC Voltage Outputs	Analog Output
VREFA	DAC External Reference Voltage	Analog Input
<b>External Interrupt Controller (EIC)</b>		
EXTINT[15:0]	External Interrupts Pins	Digital Input
NMI	Non-Maskable Interrupt Pin	Digital Input
<b>Generic Clock Generator (GCLK)</b>		
GCLK_IO[7:0]	Generators Clock Source (Input) or Generic Clock Signal (Output)	Digital I/O
<b>Custom Control Logic (CCL)</b>		
IN[11:0]	Inputs to lookup table	Digital Input
OUT[3:0]	Outputs from lookup table	Digital Output
<b>Supply Controller (SUPC)</b>		
VBAT (PB03)	External battery supply	Analog Input
OUT[1:0]	Logic Outputs	Digital Output
<b>Reset Controller (RSTC)</b>		
RESET	External Reset Pin (Active Level: LOW)	Digital Input
<b>Oscillators Control (OSCCTRL)</b>		
XIN	Crystal Oscillator or External Clock Input	Analog Input (Crystal Oscillator)/ Digital Input (External Clock)
XOUT	Crystal Oscillator Output	Analog Output
<b>32 kHz Oscillators Control (OSC32KCTRL)</b>		

.....continued		
Signal Name	Function	Type
XIN32	32.768 kHz Crystal Oscillator or External Clock Input	Analog Input (Crystal Oscillator)/ Digital Input (External Clock)
XOUT32	32.768 kHz Crystal Oscillator Output	Analog Output
<b>General Purpose I/O (PORT)</b>		
PA31 - PA30, PA27, PA25 - PA00	General Purpose I/O Pin in Port A	Digital I/O
PB31 - PB30, PB25-PB00	General Purpose I/O Pin in Port B	Digital I/O
PC31 - PC30, PC28 - PC10, PC07 - PC05, PC03-PC00	General Purpose I/O Pin in Port C	Digital I/O
PD21-PD20, PD12 - PD08, PD01 - PD00	General Purpose I/O Pin in Port D	Digital I/O
<b>Real-Time Counter (RTC)</b>		
IN[4:0]	Tamper Detection Inputs	Digital Input
OUT	Tamper Detection Outputs	Digital Output
<b>Timer Counter (TCx)</b>		
WO[1:0]	Capture Inputs or Waveform Outputs	Digital I/O
<b>Timer Counter (TCCx)</b>		
WO[7:0]	Capture Inputs or Waveform Outputs	Digital I/O
<b>Position Decoder (PDEC)</b>		
QDI[2:0]	Peripheral Decoder Inputs	Digital Input
<b>Parallel Capture Controller (PCC)</b>		
DEN1	Sensor Data Enable 1	Digital Input
DEN2	Sensor Data Enable 2	Digital Input
CLK	Sensor Clock	Digital Input
DATA[13:0]	Sensor Data	Digital Input
<b>Serial Communication Interface (SERCOMx)</b>		
PAD[3:0]	General SERCOM Pins	Digital I/O
<b>Quad Serial Peripheral Interface (QSPI)</b>		
SCK	Serial Clock	Digital Output
CS	Chip Select	Digital Output
DATA[3:0]	Data Input/Output	Digital I/O
<b>Ethernet MAC (GMAC)</b>		
GTXEN	Transmit Enable	Digital Output
GTXCK	Transmit Clock or Reference Clock	Digital I/O
GTX[3:0]	Transmit Data	Digital Output
GTXER	Transmit Coding Error	Digital I/O
GRXER	Receive Error	Digital I/O
GRXCK	Receive Clock	Digital I/O
GRX[3:0]	Receive Data	Digital I/O
GRXDV	Receive Data Valid	Digital I/O
GCOL	Collision Detect	Digital I/O
GCRS	Carrier Sense and Data Valid	Digital I/O
GTSUCOMP	TSU Timer Comparison Valid	Digital I/O
GMDIO	Management Data Input/Output	Digital I/O
GMDC	Management Data Clock	Digital Output
<b>Universal Serial Bus (USB)</b>		
DP	Differential Data Line + Port	Digital I/O

.....continued		
Signal Name	Function	Type
DM	Differential Data Line - Port	Digital I/O
SOF 1kHz	USB Start of Frame Output	Digital Output
<b>Control Area Network (CANx)</b>		
TX	CAN Transmit	Digital Output
RX	CAN Receive	Digital Input
<b>Inter-IC Sound Controller (I<sup>2</sup>S)</b>		
MCK1, MCK0	Host Clock Pins	Digital I/O
SCK1, SCK0	Serial Clock Pins	Digital I/O
FS1, FS0	I <sup>2</sup> S Word Select / TDM Frame Sync Pins	Digital I/O
SDO	Serial Data Output for Transmit Serializer	Digital Output
SDI	Serial Data Input for Receive Serializer	Digital Input
<b>SD/MMC Host Controller (SDHCx)</b>		
CD	SD Card / SDIO / e.MMC Card Detect	Digital Input
CMD	SD Card / SDIO / e.MMC Command/Response Line	Digital I/O
WP	SD Card Connector Write Protect Signal	Digital Input
CK	SD Card / SDIO / e.MMC Clock Signal	Digital Output
DAT[3:0]	SD Card / SDIO / e.MMC Data Lines	Digital I/O

## 6. Power Supplies

The PIC32CX SG41/SG60/SG61 has the following power supply pins:

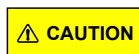
**Table 6-1.** PIC32CX SG41/SG60/SG61 Power Supplies

Name	Associated Ground	Description	Voltage Range (Electrical Characteristics Parameters Number)
VDD	VSS	Digital Supply Voltage	REG_37
AVDD	AVSS	Analog Supply Voltage	REG_39
VBAT (PB03)	-	Battery Supply Voltage which powers the Automatic Power Switch	REG_41
VDDCORE	VSS	Core Supply Voltage Output (LDO mode) Core Supply Voltage Input (BUCK mode) <b>Note:</b> VDDCORE is not an input for an external power supply.	REG_36
VSW	-	Switching Regulator Mode (BUCK) Output	-

**Note:** REG\_X values: refer to [Power Supply Electrical Specifications](#) from the “Electrical Characteristics” chapter.



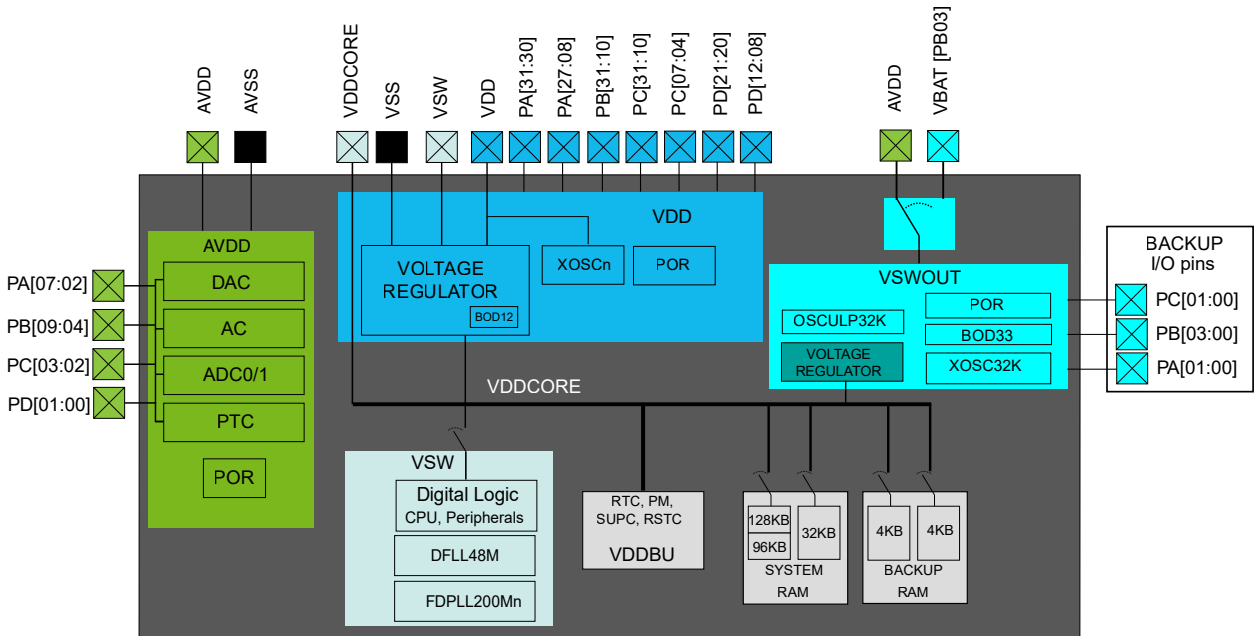
**Important:** The same voltage must be applied to VDD and AVDD. Refer to the [Power-up and Power-down Considerations](#) in the “Device Start-up” chapter for additional information.



Any and all I/O as well as digital alternate functions on AVDD analog cluster must be confined as inputs only. Refer to the I/O PINMUX tables from [Pinout and Packaging](#) chapter for the list per package of pins powered by AVDD.

**Note:**The IOSET configurations for the concerned digital alternate output functions must also be considered, refer to the [IOSET Configurations](#) in the Pinout and Packaging chapter.

Figure 6-1. Power Supplies Block Diagram



## 7. Device Start-Up

### 7.1 Power-Up Considerations

After power-up, the device is kept in reset until the power has stabilized throughout the device. VDD and AVDD must have the same supply sequence, and must be connected together.

Minimum and maximum VDD/AVDD rise and falling rates can be found in the [Power Supply Electrical Specifications](#) from the Electrical Characteristics chapter.

### 7.2 Clocks After Reset

Once the power has stabilized and the internal Reset is released, the device will use a 48 MHz clock by default. The clock source for this clock signal is DFLL48M running in Open-Loop mode, which is enabled after a reset by default. This is also the default time base for Generic Clock Generator 0. In turn, Generator 0 provides the main clock GCLK\_MAIN which is used by the Main Clock module (MCLK).

Some synchronous system clocks are active after Start-Up, allowing software execution. Refer to the “Clock Mask Registers” section in the MCLK-Main Clock documentation for the list of clocks that are running by default. Synchronous system clocks that are running receive the 48 MHz clock from Generic Clock Generator 0. Other generic clocks are disabled.

### 7.3 Initial Instructions Fetching

After Reset has been released, the CPU starts fetching PC and SP values from the Reset address, 0x00000000. This points to the first executable address in the internal Flash memory. The code read from the internal Flash can be used to configure the clock system and clock sources. Refer to the related peripheral documentation for details. Refer to the Arm “Architecture Reference Manual” for more information on CPU startup, which is available at ([www.arm.com](http://www.arm.com)).

### 7.4 I/O Pins

After power-up, the I/O pins are tri-stated except: PA24, PA25 and PA30. Pins PA24, PA25 are configured in input pull-down mode. PA30 is configured in input pull up mode in order to serve as part of the debug interface.

### 7.5 Power-on Reset and Brown-out Detector

The PIC32CX SG41/SG60/SG61 embeds the following features to monitor, warn, and/or reset the device:

- POR: Power-on Reset on the main supply (AVDD/VDD) and VSWOUT.
- BOD33: Brown-out Detector on VSWOUT or VBAT.
- Brown-out Detector internal to the voltage regulator for VDDCORE. BOD12 is calibrated in production and its calibration parameters are stored in the NVM User Row. This data should not be changed if the User Row is written to ensure correct behavior.

#### 7.5.1 Power-On Reset on VSWOUT

VSWOUT is monitored by POR. Monitoring is always activated, including at startup and during all sleep modes. If VSWOUT goes below the threshold voltage, the entire chip is reset.

#### 7.5.2 Power-On Reset on the main supply (AVDD/VDD)

The Main supply (AVDD/VDD) is monitored by POR. Monitoring is always activated, including at startup and during all sleep modes.

#### 7.5.3 Brown-Out Detector on VSWOUT/VBAT

BOD33 monitors VSWOUT or VBAT depending on configuration.

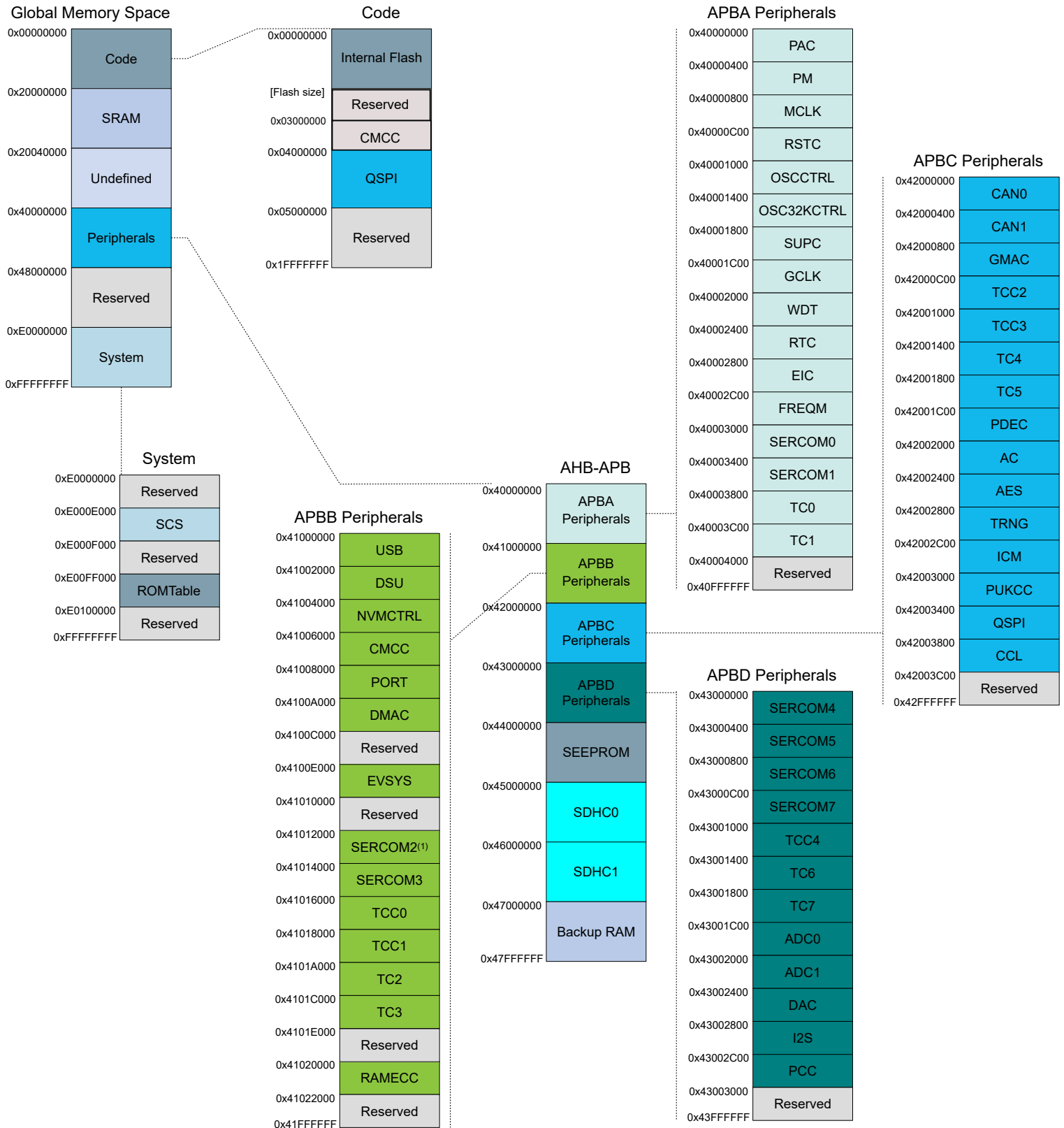


#### 7.5.4 Brown-Out Detector on VDDCORE

Once the device has started up, BOD12 monitors the internal VDDCORE.

## 8. Product Mapping

Figure 8-1. Product Mapping



**Note:**

1. SERCOM2 is assigned to the HSM interconnection (PIC32CX SG60/SG61 only).

## 9. Memories

### 9.1 Embedded Memories

- Internal high-speed Flash with Read-While-Write (RWW) capability on a section of the array
- Internal high-speed RAM, single-cycle access at full speed
- Internal backup RAM, single-cycle access at full speed

The 32-bit physical memory address space is mapped as follows:

**Table 9-1.** Memory Sizes

Memory	Start Address	Size in KB (unless otherwise stated)
Flash	0x00000000	1024
SRAM	0x20000000	256
Backup SRAM	0x47000000	8

#### 9.1.1 Flash Memory Parameters

A single page contains 512 Bytes, which is applicable to all the device part numbers listed in the [Configuration Summary](#).

**Equation 9-1.** Calculating Flash Memory

$$\text{Number of Pages} = \frac{\text{FlashSize(Bytes)}}{\text{PageSize(Bytes)}}$$

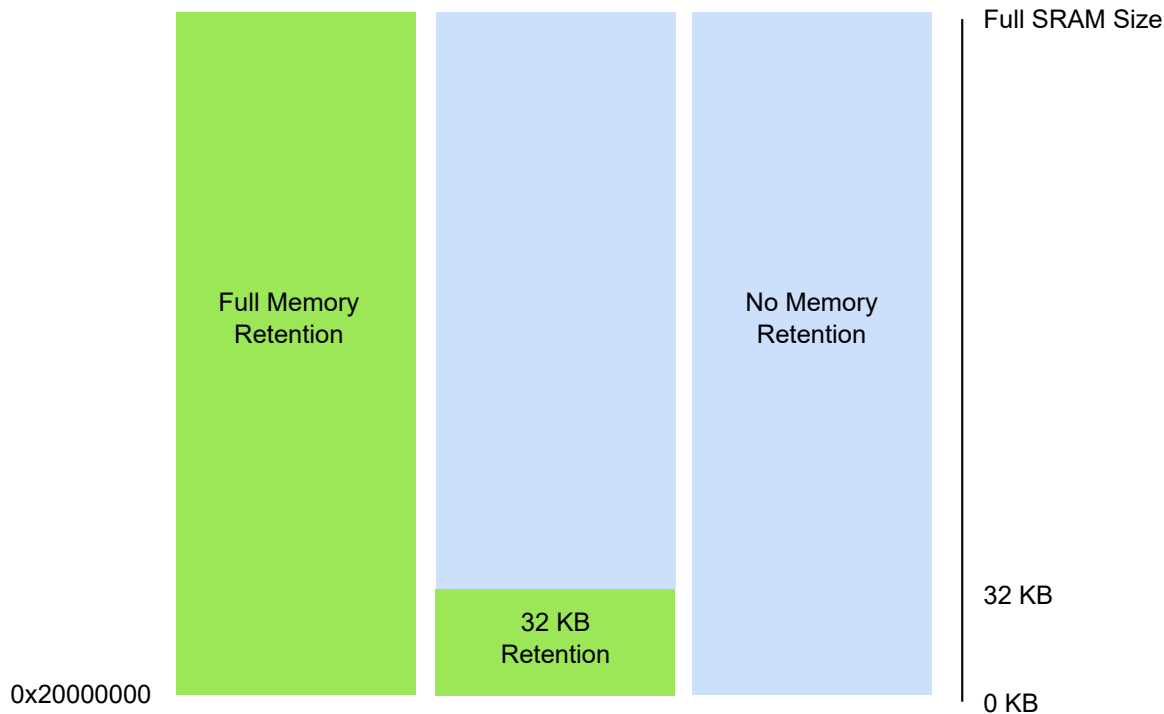
#### 9.1.2 SRAM Memory Configuration

##### Retention

Depending on the application and power budget needs, part of the system memory can be retained in Standby mode or Hibernate mode. The amount of the SRAM retained in this mode is software selectable, by writing the RAMCFG bits in the Power Manager Standby Configuration register and Hibernate Configuration register (STDBYCFG.RAMCFG and HIBCFG.RAMCFG).

By default, the entire system memory section is retained, but no retention or bottom 32 KB memory retention options are also available.

Figure 9-1. Retention Options

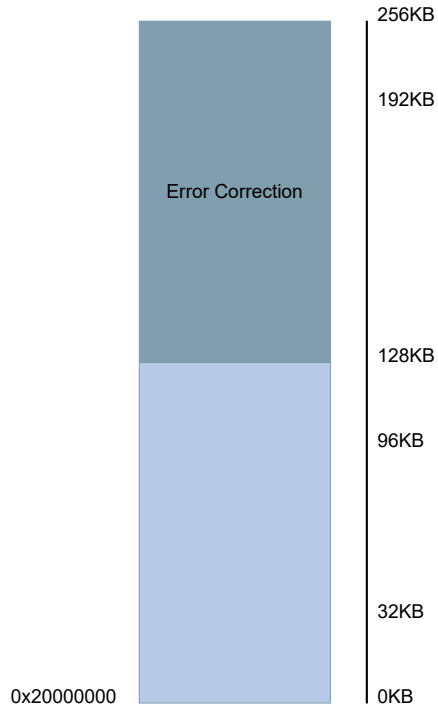


### RAM Error Correction

For safety applications, the PIC32CX SG41/SG60/SG61 family of devices embeds error correction codes (ECC) to detect and correct single bit errors, or to enable dual error detection for the system memory. The ECC is software selectable through the RAM ECCDIS bit in the NVM User Row. For additional information, refer to [Table 9-3](#).

When enabled, the top half system memory will be reserved to store the ECC, and will not be available for the application.

**Figure 9-2. Memory with RAM Error Correction**

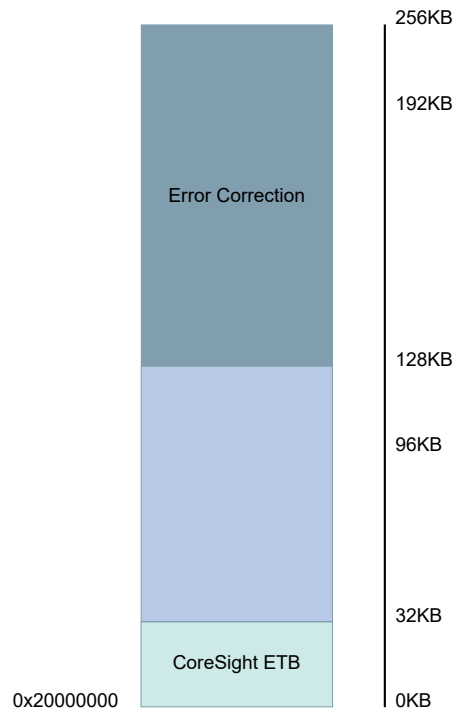


**Note:** If the ECC is used, full SRAM retention must be enabled.

**CoreSight ETB Connection**

When enabled, the bottom 32 KB system memory space is reserved for CoreSight ETB debug usage. The figure below shows an example where both ECC and CoreSight ETB are enabled.

**Figure 9-3. Memory with ECC and CoreSight ETB**



## 9.2 NVM Configuration Rows

PIC32CX SG41/SG60/SG61 have different Non Volatile Memory (NVM) Configuration rows which contain device configuration data that can be used by the system:

**Table 9-2.** NVM Configuration Rows Mapping

NVM Configuration Rows	Address
User Row (UROW)	0x00804000
Software Calibration Row (SW0)	0x00800080

### 9.2.1 NVM User Row (UROW)

The NVM User Row can be read at address 0x00804000. The size of the NVM User Row is 512 Bytes.

The first eight 32-bit words (32 Bytes) of the Non Volatile Memory (NVM) User Row contain calibration data that are automatically read at device power on. The remaining 480 Bytes can be used for storing custom parameters.

To write the NVM User Row, refer to the “NVMCTRL (Non-Volatile Memory Controller)” documentation.

When writing to the user pages, the new values do not get loaded by the other peripheral on the device until a device reset occurs.

**Note:** Before erasing the NVM User Row, ensure that the first 32 Bytes are read to a buffer and later written back to the same area unless a configuration change is intended.

**Table 9-3.** NVM User Row Mapping - Dedicated Entries

Bit Pos.	Name	Usage	Related Peripheral Register	Default Values
0	BOD33 Disable	BOD33 Disable at power-on.	SUPC.BOD33	0x0
8:1	BOD33 Level	BOD33 threshold level at power-on.	SUPC.BOD33	0x19
10:9	BOD33 Action	BOD33 Action at power-on.	SUPC.BOD33	0x1
14:11	BOD33 Hysteresis	BOD33 Hysteresis configuration at power-on.	SUPC.BOD33	0x0
25:15	BOD12 Calibration Parameters	Factory settings - do not change. <sup>(1)</sup>		-
29:26	NVM BOOTPROT	NVM Bootloader Size: (15-BOOTPROT)*8KB	NVMCTRL	0xF
31:30	Reserved	Factory settings - do not change.		-
35:32	SBLK	Number of NVM Blocks composing a SmartEEPROM sector	NVMCTRL.SEESTAT	0x0
38:36	PSZ	SmartEEPROM Page Size	NVMCTRL.SEESTAT	0x0
39	RAM ECCDIS	RAM ECC Disable	RAMECC	0x1
47:40	Reserved	Factory settings - do not change.		-
48	WDT Enable	WDT Enable at power-on.	WDT.CTRLA	0x0
49	WDT Always-On	WDT Always-On at power-on.	WDT.CTRLA	0x0
53:50	WDT Period	WDT Period at power-on.	WDT.CONFIG	0xB
57:54	WDT Window	WDT Window mode time-out at power-on.	WDT.CONFIG	0xB
61:58	WDT EWOFFSET	WDT Early Warning Interrupt Time Offset at power-on.	WDT.EWCTRL	0xB
62	WDT WEN	WDT Timer Window Mode Enable at power-on.	WDT.CTRLA	0x0
63	Reserved	Factory settings - do not change.		
95:64	NVM LOCKS	NVM Region Lock Bits.	NVMCTRL.RUNLOCK	0xFFFF FFFF
127:96	(fourth word)	User page		
159:128	Reserved	Factory settings - do not change.		

.....continued

Bit Pos.	Name	Usage	Related Peripheral Register	Default Values
Other	-	User pages		



1. BOD12 is calibrated in production, and the calibration parameters must not be changed to ensure the correct device behavior.

## 9.2.2 NVM Boot Configuration Row (BOCOR)

The NVM Boot Configuration can be read at address 0x00800030.

**Table 9-4.** NVM Boot Configuration Mapping

Bit Position	Name	Usage	Related Peripheral Register	Default Values
3:0	BOOTPROTLOCK	Boot Protection Lock	NVMCTRL.STATUS	0xF
4	DBPELOCK	Dual Boot Protection Enable Lock	NVMCTRL.STATUS	0x1
31:5	Reserved	Reserved	—	—

## 9.2.3 NVM Software Calibration Area Row (SW0)

The NVM Software Calibration Area contains calibration data that are determined and written during production test. These calibration values should be read by the application software and written back to the corresponding register.

The NVM Software Calibration Area can be read at address 0x00800080.

The NVM Software Calibration Area can not be written.

**Table 9-5.** NVM Software Calibration Area Mapping

Bit Position	Name	Description	Default Value
1:0	AC BIAS	AC Comparator 0/1 Bias Scaling. To be written to the AC CALIB register.	0x1
4:2	ADC0 BIASCOMP	Bias comparator scaling. To be written to the ADC0 CALIB register.	0x7
7:5	ADC0 BIASREFBUF	Bias reference buffer scaling. To be written to the ADC0 CALIB register.	0x7
10:8	ADC0 BIASR2R	Bias rail-to-rail amplifier scaling. To be written to the ADC0 CALIB register.	0x7
15:11	Reserved	Reserved	-
18:16	ADC1 BIASCOMP	Bias comparator scaling. To be written to the ADC1 CALIB register.	0x7
21:19	ADC1 BIASREFBUF	Bias reference buffer scaling. To be written to the ADC1 CALIB register.	0x7
24:22	ADC1 BIASR2R	Bias rail-to-rail amplifier scaling. To be written to the ADC1 CALIB register.	0x7
35:25	Reserved	Reserved	-
36:32	USB TRANSN	USB TRANSN calibration value. To be written to the USB PADCAL register.	0x09
41:37	USB TRANSP	USB TRANSP calibration value. To be written to the USB PADCAL register.	0x19
44:42	USB TRIM	USB TRIM calibration value. To be written to the USB PADCAL register.	0x6
45:63	Reserved	Reserved	-

## 9.3 Serial Number

Each device has a unique 128-bit serial number which is a concatenation of four 32-bit words contained at the following addresses:

Word 0: 0x008061FC

Word 1: 0x00806010



Word 2: 0x00806014

Word 3: 0x00806018

The uniqueness of the serial number is guaranteed only when using all 128 bits.

## 10. Processor and Architecture

### 10.1 Cortex M4 Processor

The Arm®Cortex™-M4 processor is a high performance 32-bit processor designed for the microcontroller market. It offers the following significant benefits to developers:

- Outstanding processing performance combined with fast interrupt handling
- Enhanced system debug with extensive breakpoint and trace capabilities
- Efficient processor core, system, and memories
- Ultra low-power consumption with integrated sleep modes
- Platform security robustness, with integrated memory protection unit (MPU).

The implemented Arm Cortex-M4 is revision r0p1

For additional information, refer to <http://www.arm.com>.

The Cortex-M4 processor is built on a high-performance processor core with a 3-stage pipeline Harvard architecture, making it ideal for demanding embedded applications. The processor delivers exceptional power efficiency through an efficient instruction set and extensively optimized design, providing high-end processing hardware including IEEE 754-compliant single-precision floating-point computation, a range of single-cycle and SIMD multiplication and multiply-with-accumulate capabilities, saturating arithmetic, and dedicated hardware division.

To facilitate the design of cost-sensitive devices, the Cortex-M4 processor implements tightly-coupled system components that reduce processor area while significantly improving interrupt handling and system debug capabilities. The Cortex-M4 processor implements a version of the Thumb instruction set based on Thumb®-2 technology, ensuring high code density and reduced program memory requirements. The Cortex-M4 instruction set provides the exceptional performance expected of a modern 32-bit architecture, with the high code density of 8-bit and 16-bit microcontrollers.

The Cortex-M4 processor closely integrates a configurable Nested Vector Interrupt Controller (NVIC), to deliver industry-leading interrupt performance. The NVIC includes a Non-Maskable interrupt (NMI), and provides up to 8 interrupt priority levels. The tight integration of the processor core and NVIC provides fast execution of Interrupt Service Routines (ISRs), dramatically reducing interrupt latency. This is achieved through the hardware stacking of registers, and the ability to suspend load-multiple and store-multiple operations. Interrupt handlers do not require wrapping in assembler code, removing any code overhead from the ISRs. A tail-chain optimization also significantly reduces the overhead when switching from one ISR to another.

To optimize low-power designs, the NVIC integrates with the sleep modes, that include a deep sleep function that enables the entire device to be rapidly powered down while still retaining program state.

#### 10.1.1 System Level Interface

The Cortex-M4 processor provides multiple interfaces using AMBA technology to provide high-speed, low-latency memory accesses. It supports unaligned data accesses and implements atomic bit manipulation that enables faster peripheral controls, system spinlocks, and thread-safe Boolean data handling.

The Cortex-M4 processor has a Memory Protection Unit (MPU) that provides fine grain memory control, enabling applications to utilize multiple privilege levels, separating and protecting code, data, and stack on a task-by-task basis. Such requirements are becoming critical in many embedded applications such as automotive.

### 10.1.2 Integrated Configurable Debug

The Cortex-M4 processor implements a complete hardware debug solution. This provides high system visibility of the processor and memory through a 2-pin Serial Wire Debug (SWD) port that is ideal for microcontrollers and other small package devices.

For system trace the processor integrates an Instrumentation Trace Macrocell (ITM) alongside data watchpoints and a profiling unit. The Embedded Trace Macrocell (ETM) delivers unrivaled instruction trace capture in an area far smaller than traditional trace units, enabling many low-cost MCUs to implement full instruction trace for the first time.

To enable simple and cost-effective profiling of the system events these generate, a stream of software-generated messages, data trace, and profiling information is exported over three different ways:

- Output off chip using the TPIU, through a single pin, called Serial Wire Viewer (SWV). Limited to ITM system trace
- Output off chip using the TPIU, through a 4-bit pin interface. Bandwidth is limited
- Internally stored in RAM, using the CoreSight ETB. Bandwidth is then optimal but capacity is limited

The Flash Patch and Breakpoint Unit (FPB) provides up to 8 hardware breakpoint comparators that debuggers can use. The comparators in the FPB also provide remap functions of up to 8 words in the program code in the Code memory region. This enables applications stored on a non-erasable, ROM-based microcontroller to be patched if a small programmable memory, for example Flash, is available in the device. During initialization, the application in ROM detects, from the programmable memory, whether a patch is required. If a patch is required, the application programs the FPB to remap a number of addresses. When those addresses are accessed, the accesses are redirected to a remap table specified in the FPB configuration, which means the program in the non-modifiable ROM can be patched.

### 10.1.3 Cortex-M4 Processor Features and Configuration

The following are key features and configuration of the Cortex-M4 Processor:

- Thumb® instruction set combines high code density with 32-bit performance
- IEEE 754-compliant single-precision Floating Point Unit (FPU)
- Integrated sleep modes for low power consumption
- Fast code execution permits slower processor clock or increases Sleep mode time
- Hardware division and fast digital-signal-processing orientated multiply accumulate
- Saturating arithmetic for signal processing
- Deterministic, high-performance interrupt handling for time-critical applications
- Memory Protection Unit (MPU) for safety-critical applications
- Extensive debug and trace capabilities: Serial Wire Debug and Serial Wire Trace reduce the number of pins required for debugging, tracing, and code profiling.

Features	Cortex-M4 Options	PIC32CX SG41/SG60/SG61 Configuration
Interrupts	1 to 240	138
Number of priority bits	3 to 8	3 = eight levels of priority
Data endianness	Little-endian or big-endian	Little-endian
SysTick Timer calibration value		0x80000000
MPU	Present or Not present	Present

.....continued		
Features	Cortex-M4 Options	PIC32CX SG41/SG60/SG61 Configuration
Debug support level	0 = No debug. No DAP, breakpoints, watchpoints, Flash patch, or halting debug. 1 = Minimum debug. Two breakpoints, one watchpoint, no Flash patch. 2 = Full debug minus DWT data matching. 3 = Full debug plus DWT data matching.	3 = Full debug plus DWT data matching.
Trace support level	0 = No trace. No ETM, ITM or DWT triggers and counters. 1 = Standard trace. ITM and DWT triggers and counters, but no ETM. 2 = Full trace. Standard trace plus ETM. 3 = Full trace plus HTM port.	2 = Full trace. ITM, TPIU, ETM, and DWT triggers and counters are present. HTM port is not present
JTAG	Present or Not present	Not present
Bit Banding	Present or Not present	Not present
FPU	Present or Not present	Present

### 10.1.4 Cortex-M4 Core Peripherals

<b>Nested Vectored Interrupt Controller</b>	The Nested Vector Interrupt Controller (NVIC) is an embedded interrupt controller that supports low latency interrupt processing.
<b>System Control Block</b>	The System Control Block (SCB) is the programmer's model interface to the processor. It provides system implementation information and system control, including configuration, control, and reporting of system exceptions. Refer to the Cortex-M4 Technical Reference Manual for details ( <a href="http://www.arm.com">http://www.arm.com</a> ).
<b>System Timer</b>	The system timer, SysTick, is a 24-bit count-down timer. Use this as a Real-Time Operating System (RTOS) tick timer or as a simple counter. The SysTick timer runs on the processor clock and it does not decrement when the processor is halted for debugging. Refer to the Cortex-M4 Technical Reference Manual for details ( <a href="http://www.arm.com">http://www.arm.com</a> ).
<b>Memory Protection Unit</b>	The Memory Protection Unit (MPU) improves system reliability by defining the memory attributes for different memory regions. It provides up to eight different regions, and an optional predefined background region. Refer to the Cortex-M4 Technical Reference Manual for details ( <a href="http://www.arm.com">http://www.arm.com</a> ).
<b>Floating-Point Unit</b>	The Floating Point Unit (FPU) provides IEEE 754-compliant operations on single-precision, 32-bit, floating-point values. Refer to the Cortex-M4 Technical Reference Manual for details ( <a href="http://www.arm.com">http://www.arm.com</a> ).

### 10.1.5 Cortex-M4 Address Map

Address	Core Peripheral
0xE000E008-0xE000E00F	System control block
0xE000E010-0xE000E01F	System timer
0xE000E100-0xE000E4EF	Nested Vectored Interrupt Controller
0xE000ED00-0xE000ED3F	System control block
0xE000ED90-0xE000ED93	MPU Type Register
0xE000ED90-0xE000EDB8	Memory Protection Unit
0xE000EF00-0xE000EF03	Nested Vectored Interrupt Controller
0xE000EF30-0xE000EF44	Floating Point Unit

## 10.2 Nested Vector Interrupt Controller

### 10.2.1 Overview

The Nested Vectored Interrupt Controller (NVIC) in the PIC32CX SG41/SG60/SG61 family of devices supports 138 interrupts with eight different priority levels. For additional information, refer to the "Cortex-M4 Technical Reference Manual", which is available for download at ([www.arm.com](http://www.arm.com)).

**Note:** Interrupts must be globally enabled using the `__enable_irq()` primitive before any interrupts will fire.

## 10.2.2 Interrupt Line Mapping

Each of the interrupt lines is connected to one peripheral instance, as shown in the table below. Each peripheral can have many interrupt flags, located in the peripheral's Interrupt Flag Status and Clear (INTFLAG) register.

An interrupt flag is set when the interrupt condition occurs. Each interrupt in the peripheral can be individually enabled by writing a '1' to the corresponding bit in the peripheral's Interrupt Enable Set (INTENSET) register, and disabled by writing '1' to the corresponding bit in the peripheral's Interrupt Enable Clear (INTENCLR) register.

An interrupt request is generated from the peripheral when the interrupt flag is set and the corresponding interrupt is enabled.

Depending on their criticality, the interrupt requests for one peripheral are either ORed together on system level, generating one interrupt or directly connected to an NVIC interrupt lines. This is described in the table below.

An interrupt request will set the corresponding interrupt pending bit in the NVIC interrupt pending registers (SETPEND/CLRPEND bits in ISPR/ICPR).

For the NVIC to activate the interrupt, it must be enabled in the NVIC interrupt enable register (SETENA/CLRENA bits in ISER/ICER). The NVIC interrupt priority registers IPR0-IPR7 provide a priority field for each interrupt.

Module	Source	Line
EIC NMI - External Interrupt Control	NMI	NMI
PM - Power Manager	SLEEPDY	0
MCLK - Main Clock	CKRDY	1
OSCCTRL - Oscillators Control	XOSCFail0	2
	XOSCRDY0	
	XOSCFail1	3
	XOSCRDY1	
	DFLLLOCKC	4
	DFLLLOCKF	
	DFLLOOB	
	DFLLRCS	
	DFLLRDY	
	DPLLCKF0	5
	DPLLCKR0	
	DPLLDRT00	
	DPLLLTO0	
	DPLLCKF1	6
DPLLCKR1		
DPLLDRT01		
DPLLLTO1		
OSC32KCTRL - 32 kHz Oscillators Control	XOSC32KFail	7
	XOSC32KRDY	

.....continued

Module	Source	Line
SUPC - Supply Controller	BOD33RDY	8
	B33SRDY	
	VCORERDY	
	VREGRDY	
	BOD33DET	
WDT - Watchdog Timer	EW	10
RTC - Real-Time Counter	CMP0	11
	CMP1	
	CMP2	
	CMP3	
	OVF	
	PER0	
	PER1	
	PER2	
	PER3	
	PER4	
	PER5	
	PER6	
	PER7	
	TAMPER	
	ALARM0	
ALARM1		
EIC - External Interrupt Controller	EXTINT 0	12
	EXTINT 1	13
	EXTINT 2	14
	EXTINT 3	15
	EXTINT 4	16
	EXTINT 5	17
	EXTINT 6	18
	EXTINT 7	19
	EXTINT 8	20
	EXTINT 9	21
	EXTINT 10	22
	EXTINT 11	23
	EXTINT 12	24
	EXTINT 13	25
	EXTINT 14	26
	EXTINT 15	27
FREQM - Frequency Meter	DONE	28

.....continued

Module	Source	Line	
NVMCTRL - Non-Volatile Memory Controller <sup>(1)</sup>	DONE	29	
	ADDRE		
	PROGE		
	LOCKE		
	ECCSE		
	ECCDE		
	NVME		
	SUSPE		
	SEESFULL		30
	SEESOVF		
SEEWRC			
DMAC - Direct Memory Access Controller	SUSP 0	31	
	TCMPL 0		
	TERR 0		
	SUSP 1	32	
	TCMPL 1		
	TERR 1		
	SUSP 2	33	
	TCMPL 2		
	TERR 2		
	SUSP 3	34	
	TCMPL 3		
	TERR 3		
	SUSP 4..31	35	
	TCMPL 4..31		
	TERR 4..31		
EVSYS - Event System Interface	EVD 0	36	
	OVR 0		
	EVD 1	37	
	OVR 1		
	EVD 2	38	
	OVR 2		
	EVD 3	39	
	OVR 3		
EVD 4..11	40		
OVR 4..11			
PAC - Peripheral Access Controller	ERR	41	
RAM ECC	SINGLEE	45	
	DUALE		

.....continued

Module	Source	Line
SERCOM0 - Serial Communication Interface 0 <sup>(1)</sup>	0	46
	1	47
	2	48
	3	49
	4	
	5	
	7	
SERCOM1 - Serial Communication Interface 1 <sup>(1)</sup>	0	50
	1	51
	2	52
	3	53
	4	
	5	
	7	
SERCOM2 - Serial Communication Interface 2 <sup>(1)</sup>	0	54
	1	55
	2	56
	3	57
	4	
	5	
	7	
SERCOM3 - Serial Communication Interface 3 <sup>(1)</sup>	0	58
	1	59
	2	60
	3	61
	4	
	5	
	7	
SERCOM4 - Serial Communication Interface 4 <sup>(1)</sup>	0	62
	1	63
	2	64
	3	65
	4	
	5	
	7	
SERCOM5 - Serial Communication Interface 5 <sup>(1)</sup>	0	66
	1	67
	2	68
	3	69
	4	
	5	
	7	



.....continued

Module	Source	Line	
SERCOM6 - Serial Communication Interface 6 <sup>(1)</sup>	0	70	
	1	71	
	2	72	
	3	73	
	4		
	5		
	7		
SERCOM7 - Serial Communication Interface 7 <sup>(1)</sup>	0	74	
	1	75	
	2	76	
	3	77	
	4		
	5		
	7		
CAN0 - Control Area Network 0	LINE 0	78	
	LINE 1		
CAN1 - Control Area Network 1	LINE 0	79	
	LINE 1		
USB - Universal Serial Bus	EORSM/DNRSM	80	
	EORST/RST		
	LPM/DCONN		
	LPMSUSP/DDISC		
	MSOF		
	RAMACER		
	RXSTP/TXSTP 0..7		
	STALLO STALL 0..7		
	STALL1 0..7		
	SUSPEND		
	TRFAIL0 TRFAIL 0..7		
	TRFAIL1 PERR 0..7		
	UPRSM		
	WAKEUP		
	SOF HSOFF		81
	TRCPT0 0..7		82
TRCPT1 0..7	83		
GMAC - Ethernet MAC	GMAC	84	
	WOL		

.....continued

Module	Source	Line	
TCC0 - Timer Counter Control 0	CNT	85	
	DFS		
	ERR		
	FAULTA		
	FAULTB		
	FAULT0		
	FAULT1		
	OVF		
	TRG		
	UFS		
	MC0		86
	MC1		87
	MC2		88
	MC3		89
	MC4		90
TCC1 - Timer Counter Control 1	MC5	91	
	CNT	92	
	DFS		
	ERR		
	FAULTA		
	FAULTB A		
	FAULT0		
	FAULT1		
	OVF		
	TRG		
	UFS		
	MC0		93
	MC1		94
	MC2		95
	MC3		96
TCC2 - Timer Counter Control 2	CNT		97
	DFS		
	ERR		
	FAULTA		
	FAULTB		
	FAULT0		
	FAULT1		
	OVF		
	TRG		
	UFS A		
	MC0	98	
	MC1	99	
	MC2	100	

.....continued			
Module	Source	Line	
TCC3 - Timer Counter Control 3	CNT	101	
	DFS		
	ERR		
	FAULTA		
	FAULTB		
	FAULT0		
	FAULT1		
	OVF		
	TRG		
	UFS A		
	MC0		102
	MC1		103
	TCC4 - Timer Counter Control 4		CNT
DFS			
ERR			
FAULTA			
FAULTB			
FAULT0			
FAULT1			
OVF			
TRG			
UFS			
MC0		105	
MC1		106	
TC0 - Basic Timer Counter 0		ERR A	107
	MC 0		
	MC 1		
	OVF		
TC1 - Basic Timer Counter 1	ERRA	108	
	MC0		
	MC1		
	OVF		
TC2 - Basic Timer Counter 2	ERR	109	
	MC0		
	MC1		
	OVF		
TC3 - Basic Timer Counter 3	ERR	110	
	MC0		
	MC1		
	OVF		
TC4 - Basic Timer Counter 4	ERR	111	
	MC0		
	MC1		
	OVF		

.....continued

Module	Source	Line
TC5 - Basic Timer Counter 5	ERR	112
	MC0	
	MC1	
	OVF	
TC6 - Basic Timer Counter 6	ERR	113
	MC0	
	MC1	
	OVF	
TC7 - Basic Timer Counter 7	ERR	114
	MC0	
	MC1	
	OVF	
PDEC - Position Decoder	DIR	115
	ERR	
	OVF	
	VLC	116
	MC0	
	MC1	
ADC0 - Analog Digital Converter 0	OVERRUN	118
	WINMON	
	RESRDY	119
ADC1 - Analog Digital Converter 1	OVERRUN	120
	WINMON	
	RESRDY	121
AC - Analog Comparators	COMP 0	122
	COMP 1	
	WIN 0	
DAC - Digital-to-Analog Converter	OVERRUN0	123
	OVERRUN1	
	UNDERRUN0	
	UNDERRUN1	
	EMPTY0	124
	EMPTY1	125
	RESRDY0	126
	RESRDY1	127
I2S - Inter-IC Sound Interface	RXOR0	128
	RXOR1	
	RXRDY0	
	RXRDY1	
	TXRDY0	
	TXRDY1	
	TXUR0	
	TXUR1	
PCC - Parallel Capture Controller	DRDY	129
	OVRE	

.....continued

Module	Source	Line
AES - Advanced Encryption Standard	ENCCMP	130
	GFMCMP	
TRNG - True Random Generator	DATARDY	131
ICM - Integrity Check Monitor	All ICM Interrupts	132
PUKCC - Public-Key Cryptography Controller	PUKCC	133
QSPI - Quad SPI interface	RXC	134
	DRC	
	TXC	
	ERROR	
	CSRISE	
	INSTREND	
SDHC0 - SD/MMC Host Controller 0	All SDHC0 Interrupts	135
SDHC1 - SD/MMC Host Controller 1	All SDHC1 Interrupts	136

**Note:**

1. The integer number specified in the source, refers to the respective bit position in the INTFLAG register of the respective peripheral.

## 10.3 High-Speed Bus System

### 10.3.1 Features

High-Speed Bus Matrix has the following features:

- Symmetric crossbar bus switch implementation
- Allows concurrent accesses from different Hosts to different Clients
- 32-bit data bus
- Operation at a one-to-one clock frequency with the bus Hosts

System SRAM Memory has the following features:

- Unified System Memory area
- Allows concurrent accesses from different Hosts
- Offers privileged accesses from specific Hosts

## 10.3.2 Configuration

Figure 10-1. Host-Client Relations High-Speed Bus Matrix

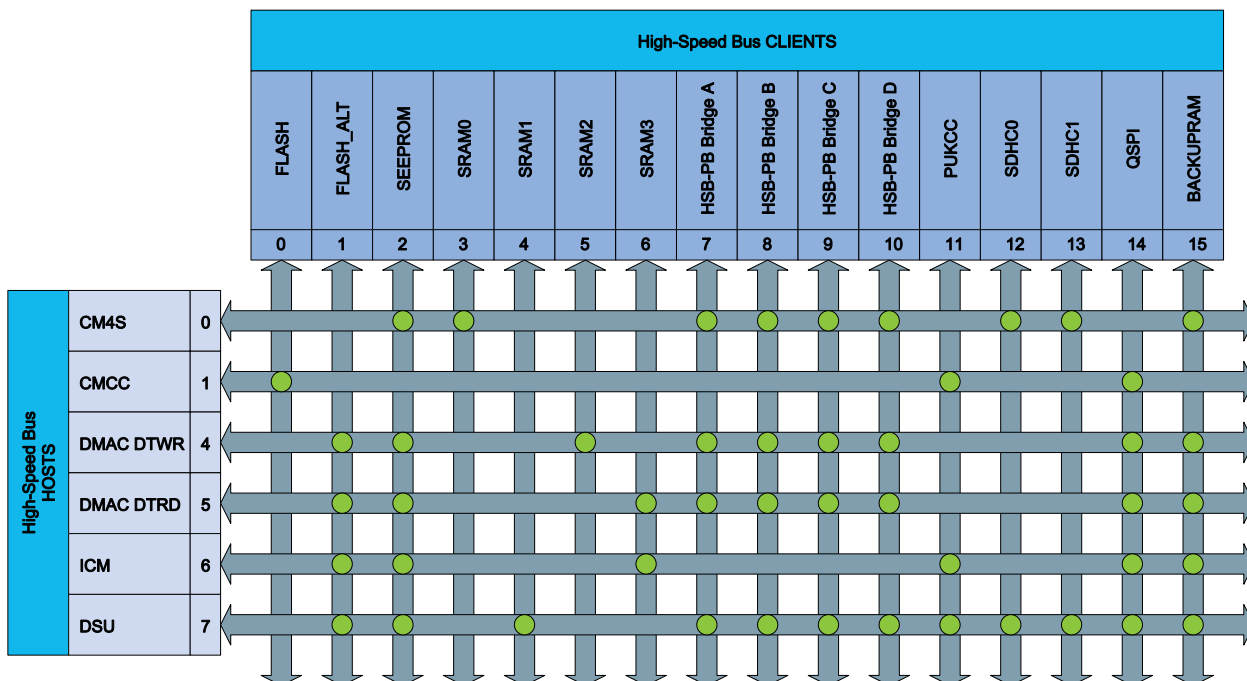


Table 10-1. High Speed Bus Matrix Hosts

High-Speed Bus Matrix Hosts	Host ID
CM4S - Cortex-M4 Processor	0
CMCC - Cortex-M Cache Controller (Cortex-M4F ICode and DCode Interfaces)	1
DMAC - Direct Memory Access Controller/Data Write Access	4
DMAC - Direct Memory Access Controller/Data Read Access	5
ICM - Integrity Check Monitor	6
DSU - Device Service Unit	7

Table 10-2. High-Speed Bus Matrix Clients

High-Speed Bus Matrix Clients	Client ID
Internal Flash Memory	0, 1
Smart EEPROM	2
SRAM Port 0 - CM4 Access	3
SRAM Port 1 - DSU Access	4
SRAM Port 2 - DMAC Data-Write Access	5
SRAM Port 3 - DMAC Data-Read and ICM Access	6
AHB-APB Bridge A	7
AHB-APB Bridge B	8
AHB-APB Bridge C	9
AHB-APB Bridge D	10
PUKCC	11
SDHC0	12
SDHC1	13
QSPI	14

.....continued

High-Speed Bus Matrix Clients	Client ID
BACKUP RAM Memory	15

### 10.3.3 SRAM Quality of Service

To ensure that Hosts with latency requirements get sufficient priority when accessing RAM, priority levels can be assigned to the Hosts for different types of access.

The Quality of Service (QoS) level is independently selected for each Host accessing the RAM. For any access to the RAM, the RAM also receives the QoS level. The QoS levels and their corresponding bit values for the QoS level configuration is shown in the table below.

**Table 10-3.** Quality of Service

Value	Name	Description
0x0	DISABLE	Background (no sensitive operation)
0x1	LOW	Sensitive Bandwidth
0x2	MEDIUM	Sensitive Latency
0x3	HIGH	Critical Latency

If a Host is configured with QoS level DISABLE (0x0) or LOW (0x1) there will be a minimum latency of one cycle for the RAM access.

The priority order for concurrent accesses are decided by two factors. First, the QoS level for the Host and second, a static priority given by the port ID. The lowest port ID has the highest static priority. See the tables below for details.

The CPU QoS level can be written/read, using 32-bit access only, at address 0x4100C11C, bits [1:0]. Its reset value is 0x3.

The ICM QoS level can be written/read, using 32-bit access only, at address 0x4100C128, bits [1:0]. Its reset value is 0x1.

Refer to different Host QoS control registers for configuring QoS for the other Hosts (DSU, DMAC, CAN, USB).

**Table 10-4.** SRAM Port Connections QoS

SRAM Port Connection	Port ID	Connection Type	QoS	default QoS
CM4 - Cortex M4 Processor	0	Bus Matrix	0x4100C11C, bits[1:0] <sup>(1)</sup>	0x3
DSU - Device Service Unit	1	Bus Matrix	IP-CFG.LQOS	0x2
DMAC - Direct Memory Access Controller - Data Access	2 (WR), 3 (RD)	Bus Matrix	IP-PRICTRL0.QOSn	0x2
ICM - Integrity Check Monitor	3	Bus Matrix	0x4100C128, bits[1:0] <sup>(1)</sup>	0x1
DMAC - Direct Memory Access Controller - Fetch Access	4, 5	Direct	IP-PRICTRL0.QOSn	0x2
DMAC - Direct Memory Access Controller - Write-Back Access	6, 7	Direct	IP-PRICTRL0.QOSn	0x2
SDHC0 - SD/MMC Host Controller	8	Direct	STATIC-1	0x1
SDHC1 - SD/MMC Host Controller	9	Direct	STATIC-1	0x1

.....continued

SRAM Port Connection	Port ID	Connection Type	QoS	default QoS
CAN0 - Control Area Network	10	Direct	IP-MRCFG.QOS	0x1
CAN1 - Control Area Network	11	Direct	IP-MRCFG.QOS	0x1
GMAC - Ethernet MAC	12	Direct	STATIC-2	0x2
USB - Universal Serial Bus - Configuration Access	13	Direct	IP-QOSCTRL.CQOS	0x3
USB - Universal Serial Bus - Data Access	13	Direct	IP-QOSCTRL.DQOS	0x3

**Note:** 1. Using 32-bit access only.



## 11. Cortex-M Cache Controller (CMCC)

### 11.1 Overview

The Cortex-M Cache Controller provides an L1 cache to the Cortex-M CPU. The CMCC sits transparently between the CPU and the cache leading to improved performance.

The CMCC interfaces with the CPU through the AHB and is connected to the APB bus interface for its configuration.

### 11.2 Features

The following are key features of the Cortex-M Cache Controller:

- Physically addressed and physically tagged
- L1 data and instruction cache set to 4 KB
- L1 cache line size set to 16 Bytes
- L1 cache integrates 32-bit bus host interface
- Unified 4-Way set associative cache architecture
- Lock-Down feature, which allows cached to be locked per way
- Write through cache operations, read allocate
- Configurable as data and instruction Tightly Coupled Memory (TCM)
- Round Robin victim selection policy
- Event Monitoring with one programmable 32-bit counter
- Cache Interface includes cache maintenance operations registers

### 11.3 Block Diagram

Figure 11-1. CMCC Block Diagram

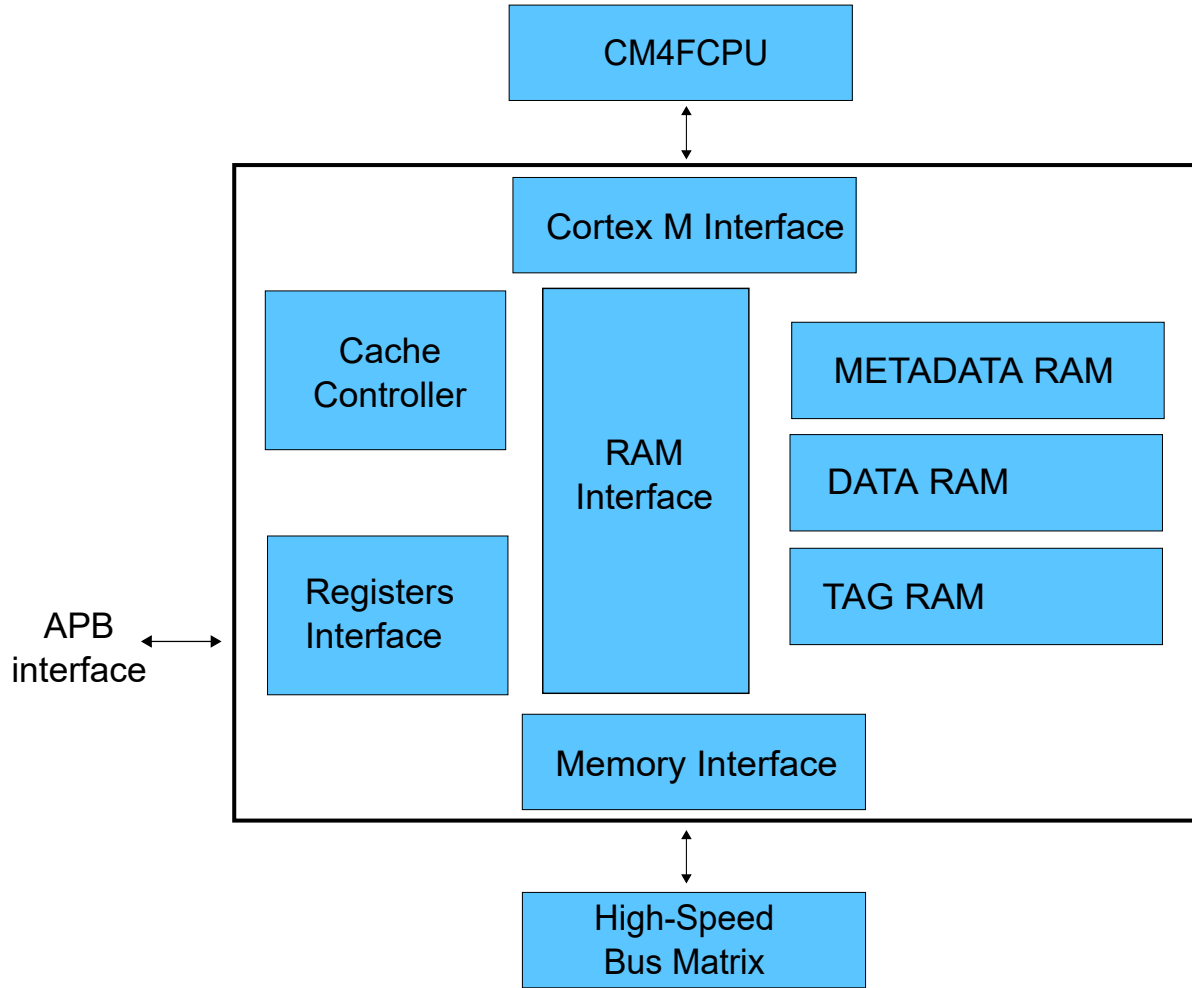
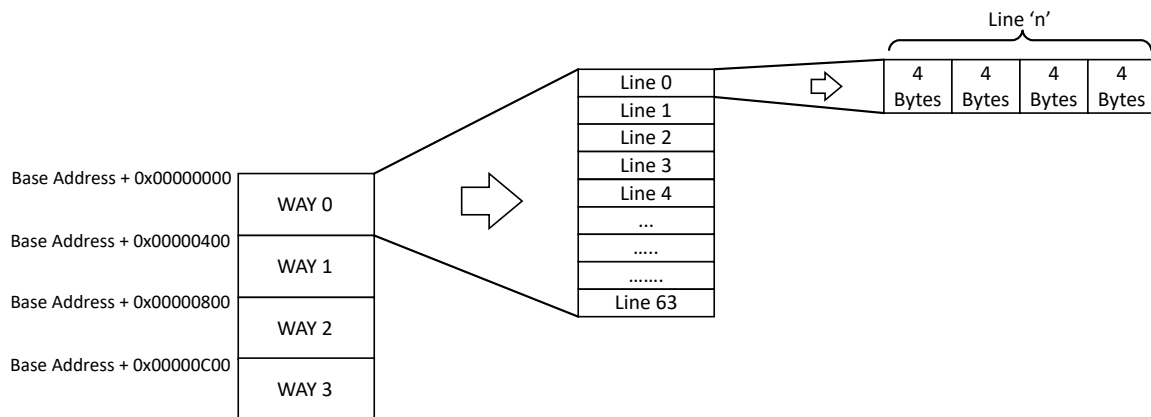


Figure 11-2. CMCC Organization



## 11.4 Peripheral Dependencies

<b>Peripheral Name</b>	CMCC - Cortex-M Cache Controller
<b>Base Address</b>	0x4100_6000 (Peripheral Bus B)
<b>MCLK APB Clock (1)</b>	CLK_CMCC_AHB, Enabled ,AHBMASK.CMCC
<b>GCLK Peripheral Channel Index:Clock Name</b>	n/a
<b>PAC Peripheral Identifier (PAC.WRCTRL)</b>	35
<b>Note:</b>	
1. Clock Name, Default State, Mask Field.	

### 11.4.1 Power Management

The CMCC will continue to function as long as the CPU is not sleeping and the CMCC is enabled.

### 11.4.2 Debug Operation

When the CPU is halted in debug mode, the CMCC is halted. Any read access by the debugger in cached zones are not cached.

## 11.5 Functional Description

### 11.5.1 Principle of Operation

### 11.5.2 Initialization and Normal Operation

On reset, the cache controller data entries are all invalidated, and the cache is disabled. The cache is transparent to processor operations. The cache controller is activated through the use of its configuration registers. The configuration interface is memory mapped in the APB bus.

Use the following sequence to enable the cache controller:

- Verify that the CMCC is disabled, reading the value of the SR.CSTS.
- Enable the CMCC by writing '1' in CTRL.CEN. The MODULE is disabled by writing a '0' in CTRL.CEN.

### 11.5.3 Change Cache Size

Users can change the cache size by writing to the Cache Size Configured By Software bits in the Cache Configuration register (CFG.CSIZESW).

Use the following sequence to change the cache size:

- Disable the CMCC controller by writing a zero to the Cache Controller Enable bit in the Cache Control register (CTRL.CEN = 0).
- Check the Cache Controller Status bit in the Cache Status register to verify that the CMCC is successfully disabled (SR.CSTS = 0).
- Change CFG.CSIZESW to its new value.
- Enable the CMCC by writing CTRL.CEN = 1.

### 11.5.4 Data Cache Disable

The Instructions alone can be cached by disabling the Data cache, as described in the following steps:

1. Disable the cache controller by writing a '0' to CTRL.CEN.
2. Check SR.CSTS to verify whether the CMCC is successfully disabled.
3. Write CFG.DCDIS = 1.
4. Enable the CMCC by writing CTRL.CEN = 1.

### 11.5.5 Instruction Cache Disable

The Data alone can be cached by disabling the Instruction cache, as described in the following steps:

1. Disable the cache controller by writing CTRL.CEN = 0.
2. Check SR.CSTS to verify that the CMCC is successfully disabled.
3. Write CFG.ICDIS = 1.
4. Enable the CMCC by writing CTRL.CEN = 1.

### 11.5.6 Cache Load and Lock

It is possible to lock a specific way for code optimization by writing the Lock Way register (LCKWAY.LCKWAY). The locked way will not be updated by the CMCC as part of cache operations.

The load and lock mechanism can be implemented to use cache memory in a deterministic way. Follow these steps to load and lock a way:

1. Disable cache controller by clearing the CTRL.CEN bit.
2. Invalidate the desired WAY line by line. This will reset the round robin algorithm of the invalidated line, that will become eligible for the next load operation.
3. Disable the Instruction cache, but keep the Data cache enabled.
4. Enable the cache by setting the CTRL.CEN bit.
5. Place the respective piece of code and/or data to the corresponding WAY due to simple LOAD operations. Loading the piece of code and/or data will force the cache to refill the previous invalidated line in the right way. No need to load all the bytes of the line, only the first byte. The cache will automatically refill the complete line.
6. Lock the specific WAY by setting LCKWAY.LCKWAY[3:0].
7. Re-enable the instruction cache. The locked WAY is now loaded and ready to operate. The remaining WAYS can be used as I-cache or D-cache as required.

### 11.5.7 Tightly Coupled Memory

Users can use a part of the cache as Tightly Coupled Memory (TCM). The cache size is determined by the Cache Size Configuration by Software bits in the Cache Configuration register (CFG.CSIZESW). The relation between cache and TCM is as given below:

TCM size = maximum Cache size - configured Cache size.

The TCM start address can be obtained from the product memory mapping. The cache memory starts first from the address followed by the TCM memory. Size of the Way is fixed and the number of ways varies according to the available size for the cache memory. For additional information, refer to the section [Product Memory Mapping](#).

**Table 11-1.** TCM Sizes

Max. Cache	Configured Cache	TCM Size
4 KB	4 KB	0 KB
4 KB	1 KB	3 KB
4 KB	2 KB	2 KB
4 KB	0 KB	4 KB

The TCM is also accessible in its maximum size when the CMCC is disabled. The TCM does not need to be locked in order to operate.

**Note:** Writing into the cache DATA RAM region through the CPU can overwrite the valid cache lines. This can result in data corruption when the cache controller is accessing the data for cache transactions. Access the DATA RAM region only after configuring it as TCM.

## 11.5.8 Cache Maintenance

### 11.5.8.1 Cache Invalidate by Line Operation

When an invalidate by line command is issued, the CMCC resets the valid bit information of the decoded cache line. As the line is no longer valid, the replacement counter points to that line.

- Disable the cache controller by writing a zero to the Cache Controller Enable bit in the Cache Control register (CTRL.CEN).
- Check SR.CSTS to verify that the CMCC is successfully disabled.
- Perform an invalidate by line by writing the set {index,way} in the Cache Maintenance 1 register (MAINT1.INDEX, MAINT1.WAY).
- Enable the CMCC by writing a '1' to CTRL.CEN.

### 11.5.8.2 Cache Invalidate All Operation

Use the following sequence to invalidate all cache entries.

- Disable the cache controller by writing a zero to the Cache Enable bit in the Cache Control register (CTRL.CEN).
- Check SR.CSTS to verify that the CMCC is successfully disabled.
- Perform a full invalidate operation by writing a '1' to the Cache Controller Invalidate All bit in the Cache Maintenance 0 register (MAINT0.INVALL).
- Enable the CMCC by writing a '1' to CTRL.CEN.

## 11.5.9 Cache Performance Monitoring

The Cortex M cache controller includes a programmable monitor/32-bit counter. The monitor can be configured to count the number of clock cycles, the number of data hit or the number of instruction hit.

It is important to know that the Cortex-M4 processor prefetches instructions ahead of execution. It performs only 32-bit read access on the Instruction Bus, which means:

- One arm instruction is fetched per bus access
- Two thumb instructions are fetched per bus access

As a consequence, two thumb instructions (e.g., `NOB`) need one bus access, which results in the HIT counter incrementing by 1.

Use the following sequence to activate the counter:

- Configure the monitor counter by writing the MCFG.MODE.
  - CYCLE\_COUNT is used to increment the counter along with the program counter, to count the number of cycles.
  - IHIT\_COUNT is the instruction Hit counter, which increments the counter when there is a hit for the instruction in the cache.
  - DHIT\_COUNT is the data Hit counter which increments the counter when there is a hit for the data in the cache.
- Enable the counter by writing a '1' to the Cache Controller Monitor Enable bit in the Cache Monitor Enable register (MEN.MENABLE).
- If required, reset the counter by writing a '1' to the Cache Controller Software Reset bit in the Cache Monitor Control register (MCTRL.SWRST).
- Check the value of the monitor counter by reading the MSR.EVENT\_CNT bit field.

## 11.6 DEBUG Mode

In Debug mode, TAG and METADATA RAM blocks content is read/written through the AHB bus interface if the CMCC is disabled. When the CMCC is enabled, the TAG and METADATA RAM blocks are non readable.

Debug access has the same R/W properties as the CPU access for the DATA RAM block.

The TAG, METADATA and DATA RAM blocks' R/W properties are summarized in [RAM Properties](#).

Use the following sequence to perform read access with the Debugger to the three RAM blocks:

- Disable the cache controller by writing a zero to the Cache Controller Enable bit in the Cache Control register (CTRL.CEN).
- Check the Cache Controller Status bit in the Cache Status register (SR.CSTS) to verify that the CMCC is successfully disabled.
- Perform a read or write access through Debugger:
  - @ CMCC\_AHB\_ADDR for DATA RAM,
  - @ CMCC\_AHB\_ADDR\_TAG for TAG RAM,
  - @ CMCC\_AHB\_ADDR\_MTDATA for METADATA RAM.
- If a write access has been performed in the TAG, METADATA, or DATA RAM in the cache section, an invalid operation must be performed before re-enabling the CMCC.

## 11.7 RAM Properties

The following table shows the different access properties of the three RAM blocks, according the different modes described in the previous chapters.

**Table 11-2.** Access to RAM

Access Condition	DATA RAM	TAG RAM	METADATARAM
CPU access when CMCC DISABLED	R/W	no R/W - hardfault	no R/W - hardfault
CPU access when CMCC ENABLED	CACHE section configured: R/W <sup>(1)</sup> TCM section configured: R/W	no R/W - hardfault	no R/W - hardfault
Debugger access when CMCC DISABLED	R/W	R/W	R/W
Debugger access when CMCC ENABLED	CACHE section configured: R/W <sup>(1)</sup> TCM section configured: R/W	no R/W	no R/W

**Note:**

1. A write operation in this zone can corrupt the coherency of the cache. An invalidate operation may be needed.

## 11.8 Register Summary

Offset	Name	Bit Pos.	7	6	5	4	3	2	1	0
0x00	TYPE	7:0	LCKDOWN	WAYNUM[1:0]		RRP			GCLK	
		15:8			CLSIZE[2:0]			CSIZE[2:0]		
		23:16								
		31:24								
0x04	CFG	7:0		CSIZESW[2:0]				DCDIS	ICDIS	
		15:8								
		23:16								
		31:24								
0x08	CTRL	7:0								CEN
		15:8								
		23:16								
		31:24								
0x0C	SR	7:0								CSTS
		15:8								
		23:16								
		31:24								
0x10	LCKWAY	7:0					LCKWAY[3:0]			
		15:8								
		23:16								
		31:24								
0x14 ... 0x1F	Reserved									
0x20	MAINT0	7:0								INVALL
		15:8								
		23:16								
		31:24								
0x24	MAINT1	7:0	INDEX[3:0]					INDEX[7:4]		
		15:8								
		23:16								
		31:24	WAY[3:0]							
0x28	MCFG	7:0							MODE[1:0]	
		15:8								
		23:16								
		31:24								
0x2C	MEN	7:0								MENABLE
		15:8								
		23:16								
		31:24								
0x30	MCTRL	7:0								SWRST
		15:8								
		23:16								
		31:24								
0x34	MSR	7:0				EVENT_CNT[7:0]				
		15:8				EVENT_CNT[15:8]				
		23:16				EVENT_CNT[23:16]				
		31:24				EVENT_CNT[31:24]				

## 11.8.1 Cache Type

**Name:** TYPE  
**Offset:** 0x00  
**Reset:** 0x000012D2  
**Property:** Read Only

Bit	31	30	29	28	27	26	25	24
Access								
Reset								
Bit	23	22	21	20	19	18	17	16
Access								
Reset								
Bit	15	14	13	12	11	10	9	8
Access			CLSIZE[2:0]			CSIZE[2:0]		
Reset			R	R	R	R	R	R
			0	1	0	0	1	0
Bit	7	6	5	4	3	2	1	0
Access	LCKDOWN	WAYNUM[1:0]		RRP			GCLK	
Reset	R	R	R	R			R	
	1	1	0	1			1	

### Bits 13:11 – CLSIZE[2:0] Cache Line Size

This field configures the Cache Line Size.

Value	Name	Description
0x0-0x1	-	Reserved
0x2	CLSIZE_16B	Cache Line Size is 16 bytes
0x3-0x7	-	Reserved

### Bits 10:8 – CSIZE[2:0] Cache Size

This bit field configures the cache size.

Value	Name	Description
0x0	CSIZE_1KB	Cache Size is 1 KB
0x1	CSIZE_2KB	Cache Size is 2 KB
0x2	CSIZE_4KB	Cache Size is 4 KB
0x3-0x7	-	Reserved

### Bit 7 – LCKDOWN Lock Down Supported

Writing a '0' to this bit disables the Lock Down feature.

Writing a '1' to this bit enables the Lock Down feature.

Value	Description
0	Lock Down feature is not supported.
1	Lock Down feature is supported.

### Bits 6:5 – WAYNUM[1:0] Number of Way

This bit field configures the mapping of the cache.

Value	Name	Description
0x0-0x1	-	Reserved
0x2	ARCH4WAY	4-WAY set associative



Value	Name	Description
0x3	-	Reserved

**Bit 4 – RRP** Round Robin Policy Supported

Writing a '0' to this bit disables Round Robin Policy.

Writing a '1' to this bit enables Round Robin Policy.

Value	Description
0	Round Robin Policy is disabled.
1	Round Robin Policy is enabled.

**Bit 1 – GCLK** Dynamic Clock Gating

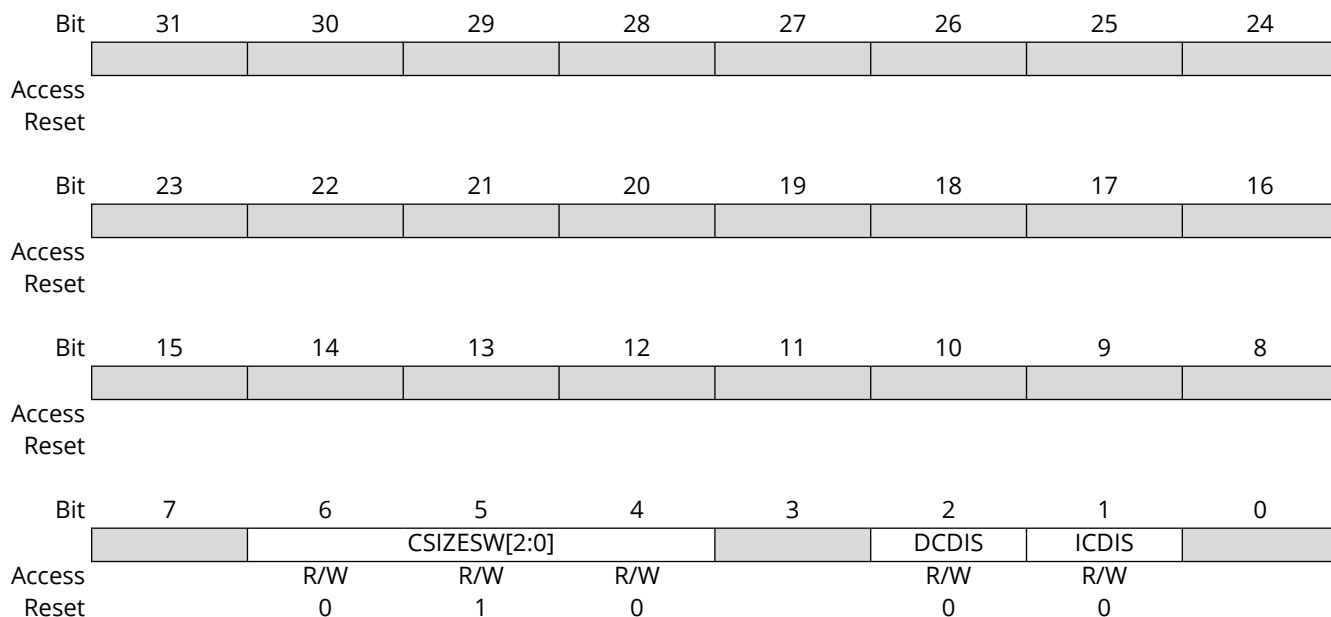
Writing a '0' to this bit disables the Dynamic Clock Gating feature.

Writing a '1' to this bit enables the Dynamic Clock Gating feature.

Value	Description
0	Dynamic Clock Gating is disabled.
1	Dynamic Clock Gating is enabled.

## 11.8.2 Cache Configuration

**Name:** CFG  
**Offset:** 0x04  
**Reset:** 0x00000020  
**Property:** R/W



### Bits 6:4 – CSIZESW[2:0] Cache Size Configured by Software

This field configures the cache size.

Value	Name	Description
0x0	CONF_CSIZ_1KB	The Cache Size is configured to 1KB
0x1	CONF_CSIZ_2KB	The Cache Size is configured to 2KB
0x2	CONF_CSIZ_4KB	The Cache Size is configured to 4KB
0x3–0x7	-	Reserved

### Bit 2 – DCDIS Data Cache Disable

Writing a '0' to this bit enables data caching.  
 Writing a '1' to this bit disables data caching.

Value	Description
0	Data caching is enabled.
1	Data caching is disabled.

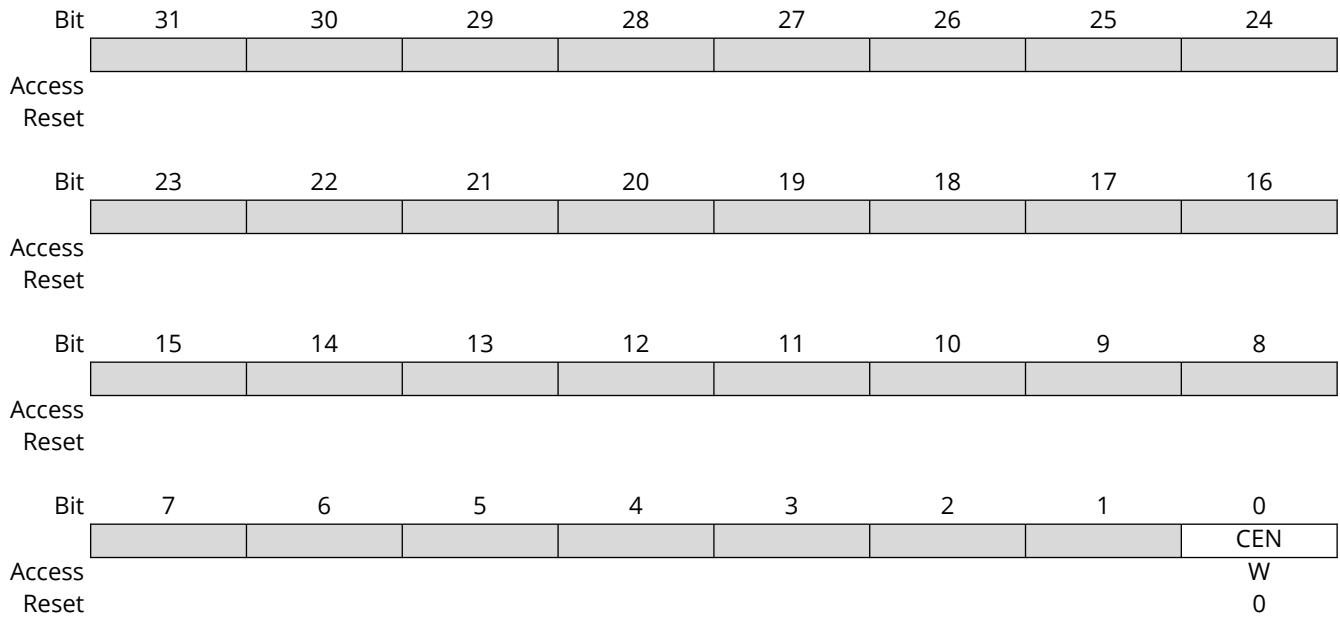
### Bit 1 – ICDIS Instruction Cache Disable

Writing a '0' to this bit enables instruction caching.  
 Writing a '1' to this bit disables instruction caching.

Value	Description
0	Instruction caching is enabled.
1	Instruction caching is disabled.

### 11.8.3 Cache Control

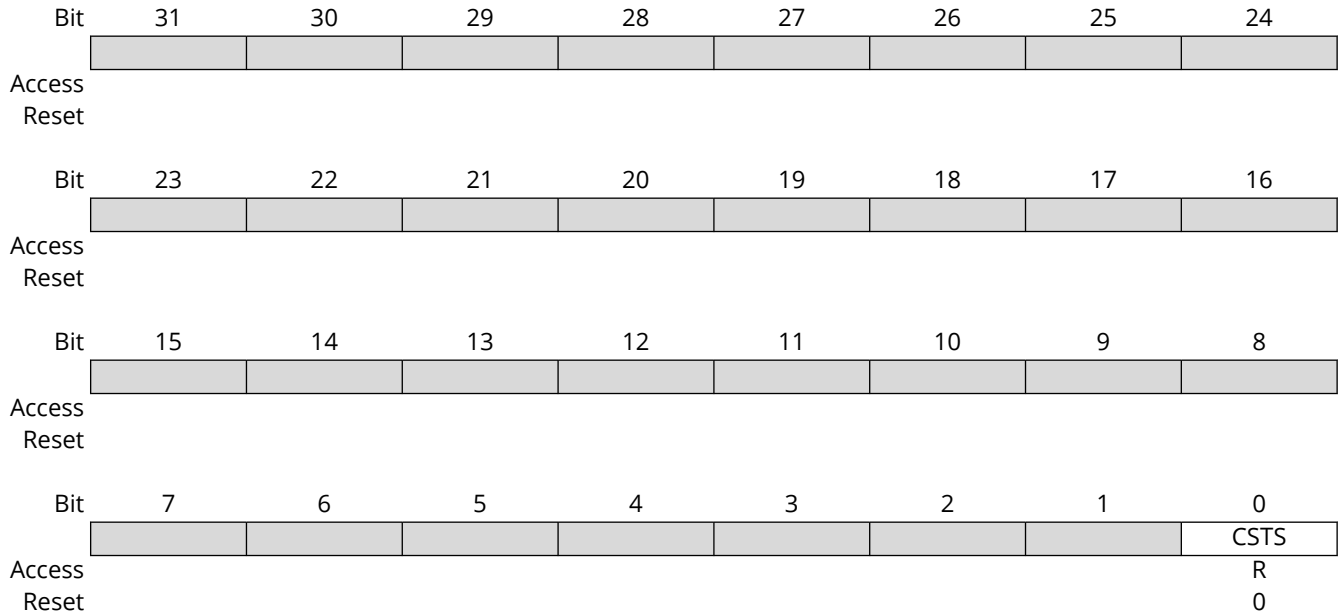
**Name:** CTRL  
**Offset:** 0x08  
**Reset:** 0x00000000  
**Property:** Write-only



**Bit 0 - CEN** Cache Controller Enable  
 Writing a '0' to this bit disables the CMCC.  
 Writing a '1' to this bit enables the CMCC.

### 11.8.4 Cache Status

**Name:** SR  
**Offset:** 0x0C  
**Reset:** 0x00000000  
**Property:** Read-only



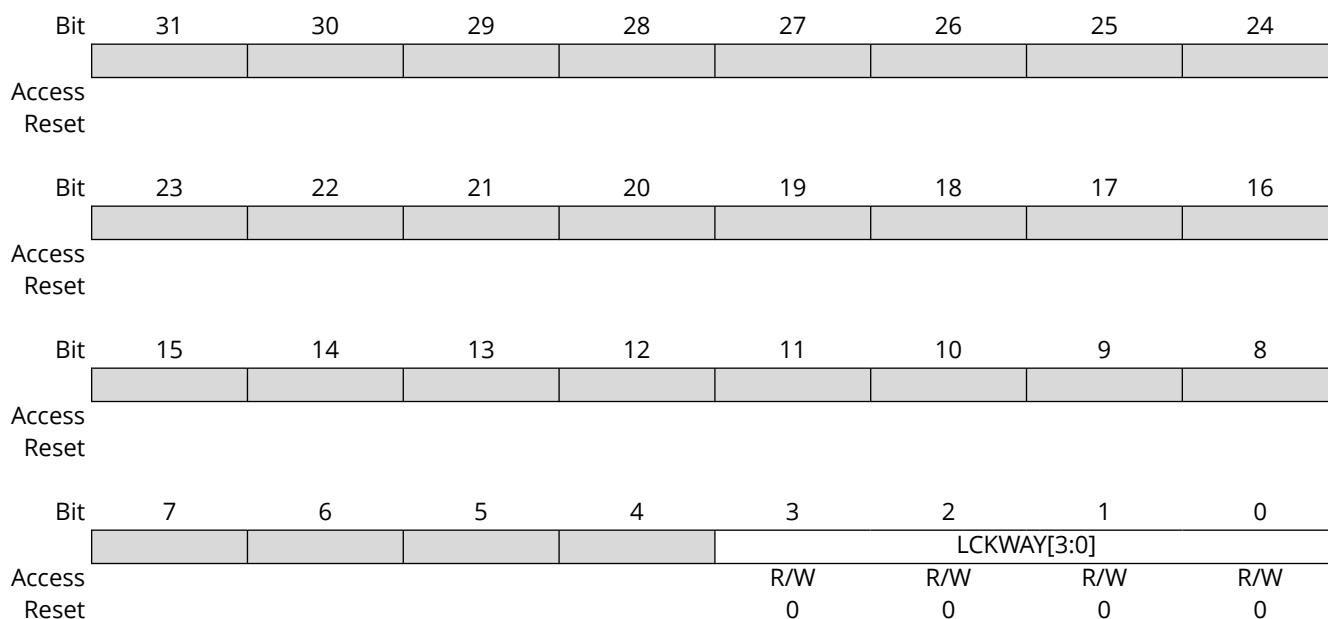
**Bit 0 - CSTS** Cache Controller Status  
 Writing to this bit has no effect.

### 11.8.5 Cache Lock per Way

**Name:** LCKWAY  
**Offset:** 0x10  
**Reset:** 0x00000000  
**Property:** Read/Write

**Table 11-3.** Register Bit Attribute Legend

Symbol	Description	Symbol	Description	Symbol	Description
<b>R</b>	Readable bit	<b>HC</b>	Cleared by Hardware	(Grey cell)	Unimplemented
<b>W</b>	Writable bit	<b>HS</b>	Set by Hardware	<b>X</b>	Bit is unknown at Reset
<b>K</b>	Write to clear	<b>S</b>	Software settable bit	—	—



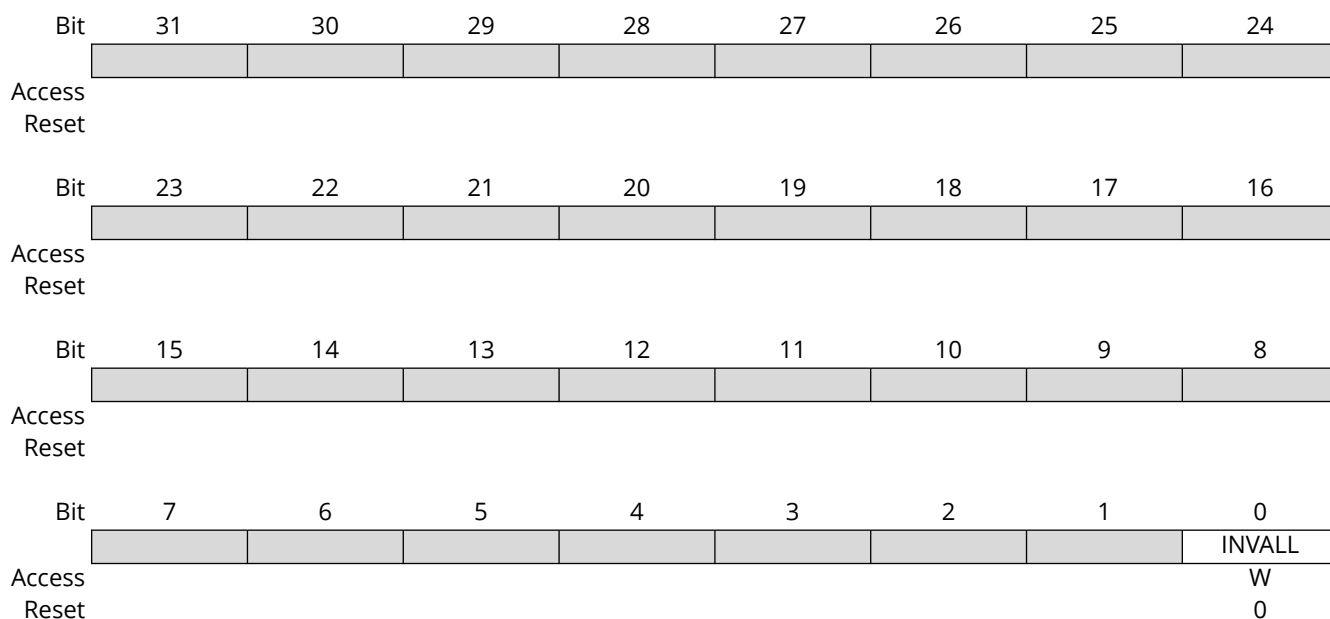
**Bits 3:0 - LCKWAY[3:0]** Lockdown Way Register  
 This field selects which way is locked.

## 11.8.6 Cache Maintenance 0

**Name:** MAINT0  
**Offset:** 0x20  
**Reset:** 0x00000000  
**Property:** Write-only

**Table 11-4.** Register Bit Attribute Legend

Symbol	Description	Symbol	Description	Symbol	Description
<b>R</b>	Readable bit	<b>HC</b>	Cleared by Hardware	(Grey cell)	Unimplemented
<b>W</b>	Writable bit	<b>HS</b>	Set by Hardware	<b>X</b>	Bit is unknown at Reset
<b>K</b>	Write to clear	<b>S</b>	Software settable bit	—	—



**Bit 0 – INVALL** Cache Controller Invalidate All  
 Writing a '0' to this bit has no effect.  
 Writing a '1' to this bit invalidates all cache entries.

## 11.8.7 Cache Maintenance 1

**Name:** MAINT1  
**Offset:** 0x24  
**Reset:** 0x00000000  
**Property:** Write-only

**Table 11-5. Register Bit Attribute Legend**

Symbol	Description	Symbol	Description	Symbol	Description
<b>R</b>	Readable bit	<b>HC</b>	Cleared by Hardware	(Grey cell)	Unimplemented
<b>W</b>	Writable bit	<b>HS</b>	Set by Hardware	<b>X</b>	Bit is unknown at Reset
<b>K</b>	Write to clear	<b>S</b>	Software settable bit	—	—

Bit	31	30	29	28	27	26	25	24
	WAY[3:0]							
Access	W	W	W	W				
Reset	0	0	0	0				
Bit	23	22	21	20	19	18	17	16
Access								
Reset								
Bit	15	14	13	12	11	10	9	8
					INDEX[7:4]			
Access					W	W	W	W
Reset					0	0	0	0
Bit	7	6	5	4	3	2	1	0
	INDEX[3:0]							
Access	W	W	W	W				
Reset	0	0	0	0				

### Bits 31:28 – WAY[3:0] Invalidate Way

Value	Name	Description
0x0	WAY0	Way 0 is selection for index invalidation
0x1	WAY1	Way 1 is selection for index invalidation
0x2	WAY2	Way 2 is selection for index invalidation
0x3	WAY3	Way 3 is selection for index invalidation
0x4–0xF		Reserved

### Bits 11:4 – INDEX[7:0] Invalidate Index

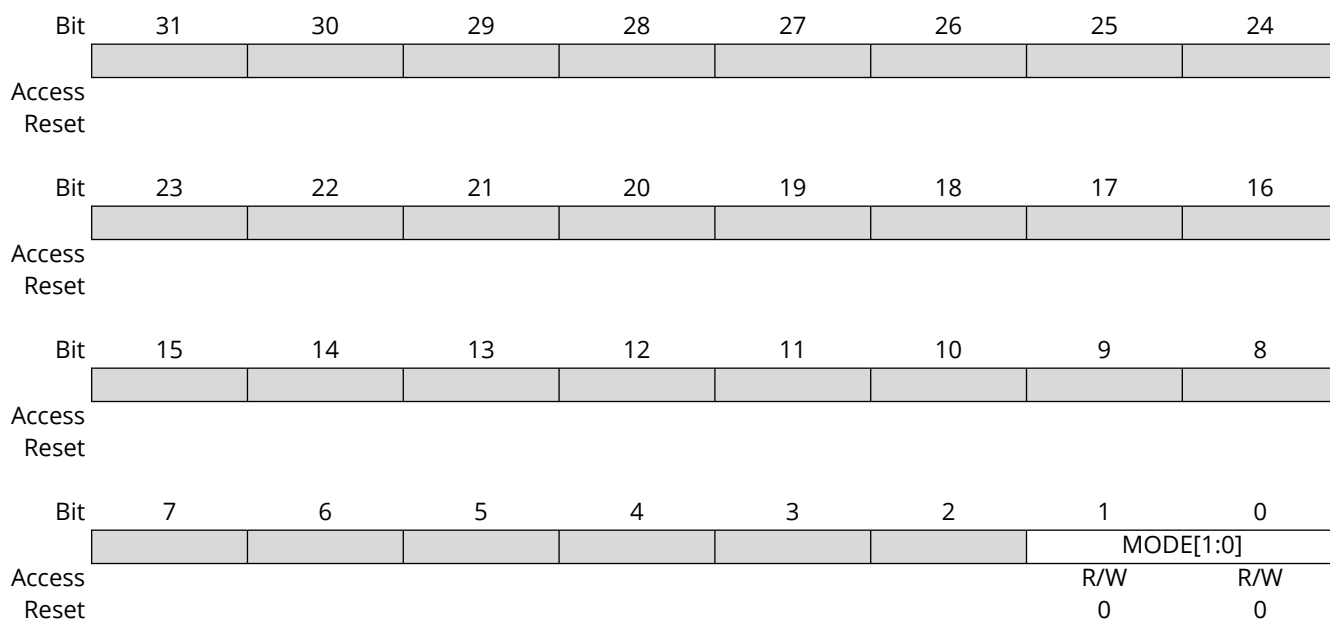
This field selects the index value for invalidation

## 11.8.8 Cache Monitor Configuration

**Name:** MCFG  
**Offset:** 0x28  
**Reset:** 0x00000000  
**Property:** Read/Write

**Table 11-6.** Register Bit Attribute Legend

Symbol	Description	Symbol	Description	Symbol	Description
<b>R</b>	Readable bit	<b>HC</b>	Cleared by Hardware	(Grey cell)	Unimplemented
<b>W</b>	Writable bit	<b>HS</b>	Set by Hardware	<b>X</b>	Bit is unknown at Reset
<b>K</b>	Write to clear	<b>S</b>	Software settable bit	—	—



### Bits 1:0 – MODE[1:0] Cache Controller Monitor Counter Mode

This field selects the type of data monitored.

Value	Name	Description
0x0	CYCLE_COUNT	Cycle counter
0x1	IHIT_COUNT	Instruction hit counter
0x2	DHIT_COUNT	Data hit counter
0x3		Reserved

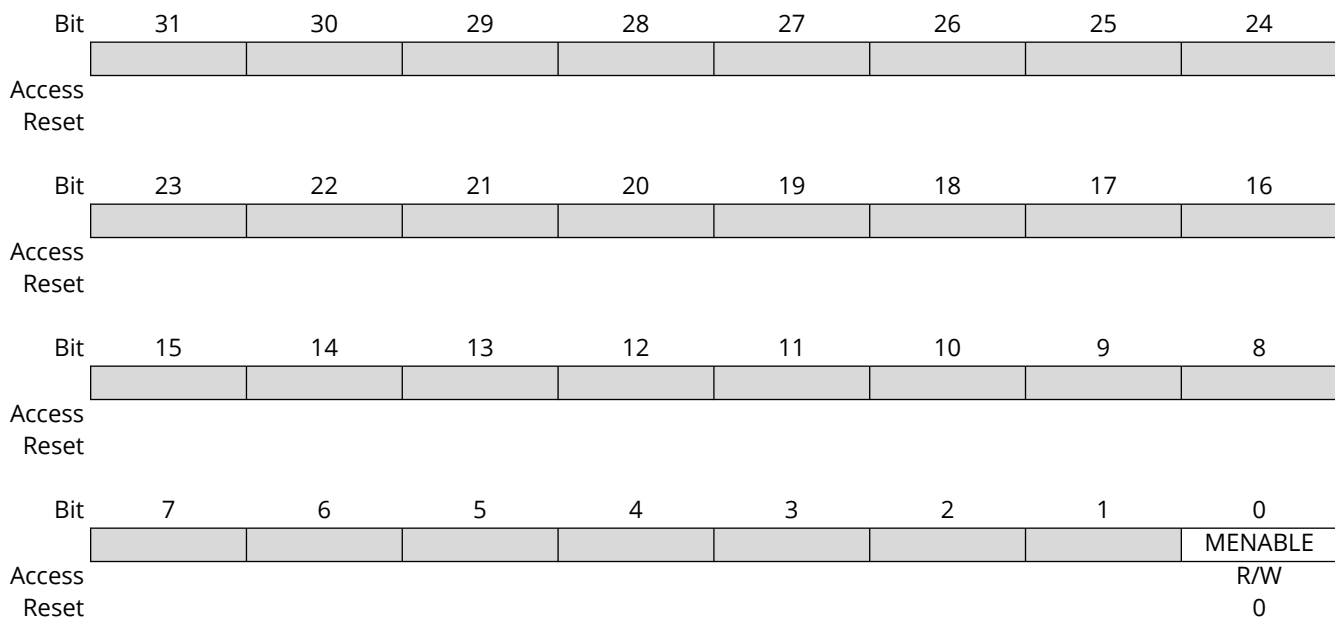


### 11.8.9 Cache Monitor Enable

**Name:** MEN  
**Offset:** 0x2C  
**Reset:** 0x00000000  
**Property:** Read/Write

**Table 11-7. Register Bit Attribute Legend**

Symbol	Description	Symbol	Description	Symbol	Description
<b>R</b>	Readable bit	<b>HC</b>	Cleared by Hardware	(Grey cell)	Unimplemented
<b>W</b>	Writable bit	<b>HS</b>	Set by Hardware	<b>X</b>	Bit is unknown at Reset
<b>K</b>	Write to clear	<b>S</b>	Software settable bit	—	—



**Bit 0 – MENABLE** Cache Controller Monitor Enable  
 Writing a '0' to this bit disables the monitor counter.  
 Writing a '1' to this bit enables the monitor counter.

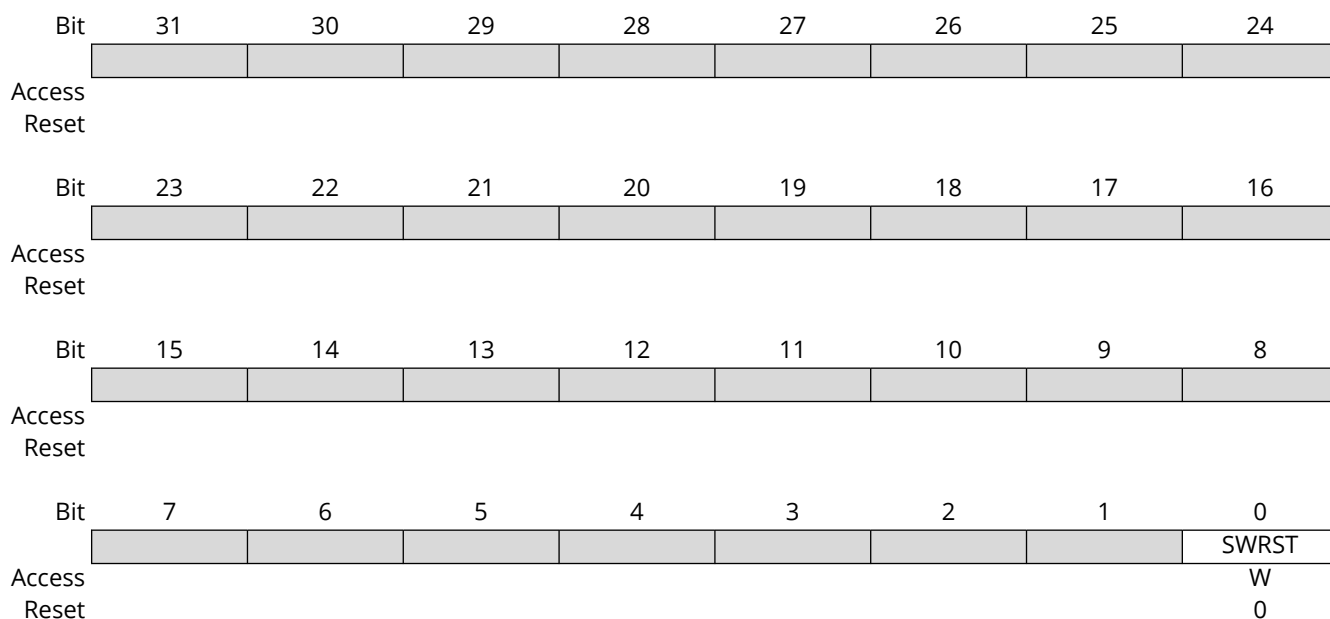
Value	Description
0	The Monitor counter is disabled.
1	The Monitor counter is enabled.

### 11.8.10 Cache Monitor Control

**Name:** MCTRL  
**Offset:** 0x30  
**Reset:** 0x00000000  
**Property:** Write-only

**Table 11-8.** Register Bit Attribute Legend

Symbol	Description	Symbol	Description	Symbol	Description
<b>R</b>	Readable bit	<b>HC</b>	Cleared by Hardware	(Grey cell)	Unimplemented
<b>W</b>	Writable bit	<b>HS</b>	Set by Hardware	<b>X</b>	Bit is unknown at Reset
<b>K</b>	Write to clear	<b>S</b>	Software settable bit	—	—



**Bit 0 – SWRST** Cache Controller Software Reset  
 Writing a '0' to this bit has no effect.  
 Writing a '1' to this bit resets the event counter register.

### 11.8.11 Cache Monitor Status

**Name:** MSR  
**Offset:** 0x34  
**Reset:** 0x00000000  
**Property:** Read-only

**Table 11-9.** Register Bit Attribute Legend

Symbol	Description	Symbol	Description	Symbol	Description
<b>R</b>	Readable bit	<b>HC</b>	Cleared by Hardware	(Grey cell)	Unimplemented
<b>W</b>	Writable bit	<b>HS</b>	Set by Hardware	<b>X</b>	Bit is unknown at Reset
<b>K</b>	Write to clear	<b>S</b>	Software settable bit	—	—

Bit	31	30	29	28	27	26	25	24
	EVENT_CNT[31:24]							
Access	R	R	R	R	R	R	R	R
Reset	0	0	0	0	0	0	0	0
Bit	23	22	21	20	19	18	17	16
	EVENT_CNT[23:16]							
Access	R	R	R	R	R	R	R	R
Reset	0	0	0	0	0	0	0	0
Bit	15	14	13	12	11	10	9	8
	EVENT_CNT[15:8]							
Access	R	R	R	R	R	R	R	R
Reset	0	0	0	0	0	0	0	0
Bit	7	6	5	4	3	2	1	0
	EVENT_CNT[7:0]							
Access	R	R	R	R	R	R	R	R
Reset	0	0	0	0	0	0	0	0

**Bits 31:0 – EVENT\_CNT[31:0]** Monitor Event Counter  
This field indicates the Monitor Event Counter value.

## 12. Peripheral Access Controller (PAC)

### 12.1 Overview

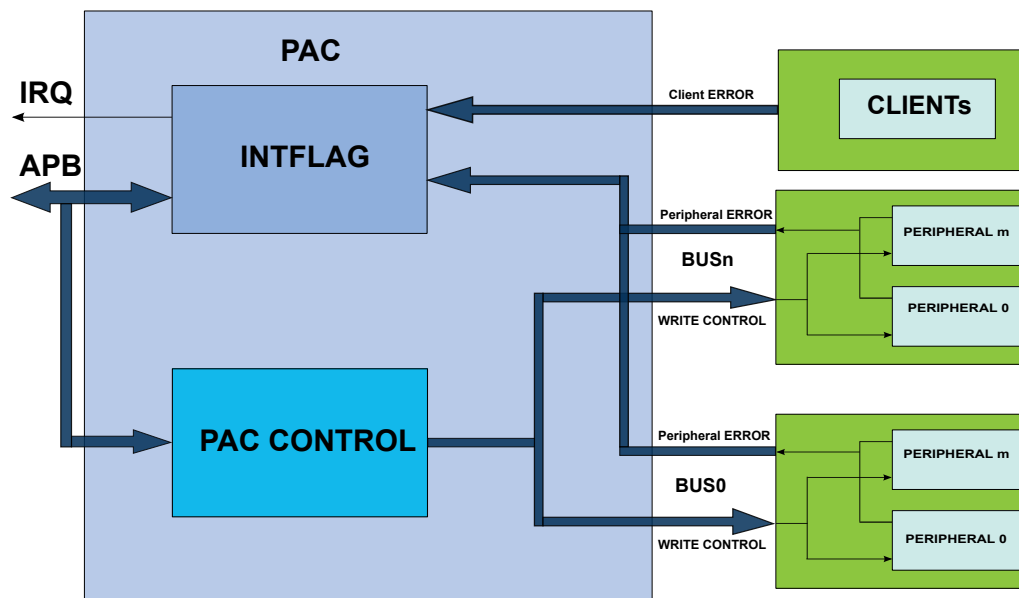
The Peripheral Access Controller provides an interface for the locking and unlocking of peripheral registers within the device. It reports all violations that could happen when accessing a peripheral: write protected access, illegal access, access when clock synchronization or software reset is on-going. These errors are reported in a unique interrupt flag for a peripheral. The PAC module also reports errors occurring at the Client bus level, when an access to a non-existing address is detected.

### 12.2 Features

The PAC module manages write protection access and reports access errors for the peripheral modules or bridges.

### 12.3 Block Diagram

Figure 12-1. PAC Block Diagram



### 12.4 Peripheral Dependencies

<b>Peripheral Name</b>	PAC - Peripheral Access Controller
<b>Base Address</b>	0x4000_0000 (Peripheral Bus A)
<b>NVIC IRQ Index:Source</b>	41 : ERR
<b>MCLK APB Clock(1)</b>	CLK_PAC_AHB, Enabled, AHBMASK.PAC CLK_PAC_APB, Enabled, APBAMASK.PAC
<b>GCLK Peripheral Channel Index:Clock Name</b>	n/a
<b>PAC Peripheral Identifier (PAC.WRCTRL)</b>	0
<b>EVSYS Users (EVSYS.USERm)</b>	n/a
<b>EVSYS Generators (EVSYS.CHANNELn)</b>	38 : PAC Access Error (PAC_ACCERR)
<b>Note:</b>	
1.	Clock Name, Default State, Mask Field.

### 12.4.1 Power Management

The PAC can continue to operate in any Sleep mode where the selected source clock is running. The PAC interrupts can be used to wake up the device from Sleep modes. The events can trigger other operations in the system without exiting sleep modes.

### 12.4.2 Clocks

The PAC bus clocks (CLK\_PAC\_APB and CLK\_PAC\_AHB) can be enabled and disabled in the [Main Clock module](#).

### 12.4.3 Debug Operation

When the CPU is halted in Debug mode, write protection of all peripherals is disabled and the PAC continues normal operation.

### 12.4.4 Register Access Protection

All registers with write access can be write-protected optionally by the Peripheral Access Controller (PAC), except for the following PAC registers:

- Write Control (WRCTRL) register
- AHB Client Bus Interrupt Flag Status and Clear (INTFLAGAHB) register
- Peripheral Interrupt Flag Status and Clear n (INTFLAG A/B/C...) registers

Optional write protection by the Peripheral Access Controller (PAC) is denoted by the "PAC Write Protection" property in each individual register description.

**Note:** PAC write protection does not apply to accesses through an external debugger.

## 12.5 Functional Description

### 12.5.1 Principle of Operation

The Peripheral Access Control module allows the user to set a write protection on peripheral modules and generate an interrupt in case of a peripheral access violation. The peripheral's protection can be set, cleared or locked at the user discretion. A set of Interrupt Flag and Status registers informs the user on the status of the violation in the peripherals. In addition, Client bus errors can be also reported in the cases where reserved area is accessed by the application.

### 12.5.2 Basic Operation

#### 12.5.2.1 Initialization, Enabling and Resetting

The PAC is always enabled after reset.

Only a hardware reset will reset the PAC module.

#### 12.5.2.2 Operations

The PAC module allows the user to set, clear or lock the write protection status of all peripherals on all Peripheral Bridges.

If a peripheral register violation occurs, the Peripheral Interrupt Flag n registers (INTFLAGn) are updated to inform the user on the status of the violation in the peripherals connected to the Peripheral Bridge n (n = A,B,C ...). The corresponding Peripheral Write Control Status n register (STATUSn) gives the state of the write protection for all peripherals connected to the corresponding Peripheral Bridge n. Refer to [12.5.2.3. Peripheral Access Errors](#) for details.

The PAC module also report the errors occurring at Client bus level when an access to reserved area is detected. AHB Client Bus Interrupt Flag register (INTFLAGAHB) informs the user on the status of the violation in the corresponding Client. Refer to the [12.5.2.6. AHB Client Bus Errors](#) for details.

#### 12.5.2.3 Peripheral Access Errors

The following events will generate a Peripheral Access Error:

- Protected write: To avoid unexpected writes to a peripheral's registers, each peripheral can be write protected. Only the registers denoted as "PAC Write-Protection" in the module's data sheet can be protected. If a peripheral is not write protected, write data accesses are performed normally. If a peripheral is write protected and if a write access is attempted, data will not be written and peripheral returns an access error. The corresponding interrupt flag bit in the INTFLAGn register will be set.
- Illegal access: Access to an unimplemented register within the module.
- Synchronized write error: For write-synchronized registers an error will be reported if the register is written while a synchronization is ongoing.

When any of the INTFLAGn registers bit are set, an interrupt will be requested if the PAC interrupt enable bit is set.

#### 12.5.2.4 Write Access Protection Management

Peripheral access control can be enabled or disabled by writing to the WRCTRL register.

The data written to the WRCTRL register is composed of two fields; WRCTRL.PERID and WRCTRL.KEY. The WRCTRL.PERID is an unique identifier corresponding to a peripheral. The WRCTRL.KEY is a key value that defines the operation to be done on the control access bit. These operations can be "clear protection", "set protection" and "set and lock protection bit".

The "clear protection" operation will remove the write access protection for the peripheral selected by WRCTRL.PERID. Write accesses are allowed for the registers in this peripheral.

The "set protection" operation will set the write access protection for the peripheral selected by WRCTRL.PERID. Write accesses are not allowed for the registers with write protection property in this peripheral.

The "set and lock protection" operation will set the write access protection for the peripheral selected by WRCTRL.PERID and locks the access rights of the selected peripheral registers. The write access protection will only be cleared by a hardware reset.

The peripheral access control status can be read from the corresponding STATUSn register.

#### 12.5.2.5 Write Access Protection Management Errors

Only word-wise writes to the WRCTRL register will effectively change the access protection. Other type of accesses will have no effect and will cause a PAC write access error. This error is reported in the INTFLAGx.PAC bit corresponding to the module.

PAC also offers an additional safety feature for correct program execution with an interrupt generated on double write clear protection or double write set protection. If a peripheral is write protected and a subsequent set protection operation is detected then the PAC returns an error, and similarly for a double clear protection operation.

In addition, an error is generated when writing a "set and lock" protection to a write-protected peripheral or when a write access is done to a locked set protection. This can be used to ensure that the application follows the intended program flow by always following a write protect with an unprotect and conversely. However in applications where a write protected peripheral is used in several contexts, e.g. interrupt, care should be taken so that either the interrupt can not happen while the main application or other interrupt levels manipulates the write protection status or when the interrupt handler needs to unprotect the peripheral based on the current protection status by reading the STATUS register.

The errors generated while accessing the PAC module registers (eg. key error, double protect error...) will set the INTFLAGx.PAC flag.

#### 12.5.2.6 AHB Client Bus Errors

The PAC module reports errors occurring at the AHB Client bus level. These errors are generated when an access is performed at an address where no Client (bridge or peripheral) is mapped . These errors are reported in the corresponding bits of the INTFLAGAHB register.

### 12.5.2.7 Generating Events

The PAC module can also generate an event when any of the Interrupt Flag registers bit are set. To enable the PAC event generation, the control bit EVCTRL.ERREO must be set a '1'.

### 12.5.3 Interrupts

The PAC has the following interrupt source:

- Error (ERR): Indicates that a peripheral access violation occurred in one of the peripherals controlled by the PAC module, or a bridge error occurred in one of the bridges reported by the PAC
  - This interrupt is a synchronous wake-up source

Each interrupt source has an interrupt flag associated with it. The interrupt flag in the Interrupt Flag Status and Clear (INTFLAGAHB and INTFLAGn) registers is set when the interrupt condition occurs. Each interrupt can be individually enabled by writing a '1' to the corresponding bit in the Interrupt Enable Set (INTENSET) register, and disabled by writing a '1' to the corresponding bit in the Interrupt Enable Clear (INTENCLR) register. The status of enabled interrupts can be read from either INTENSET or INTENCLR.

An interrupt request is generated when the interrupt flag is set and the corresponding interrupt is enabled. The interrupt request remains active until the interrupt flag is cleared, the interrupt is disabled, or the PAC is reset. All interrupt requests from the peripheral are ORed together on system level to generate one combined interrupt request to the [NVIC](#). The user must read the INTFLAGAHB and INTFLAGn registers to determine which interrupt condition is present.

Note that interrupts must be globally enabled for interrupt requests to be generated.

### 12.5.4 Events

The PAC can generate the following output event:

- Error (ERR): Generated when one of the interrupt flag registers bits is set

Writing a '1' to an Event Output bit in the Event Control Register (EVCTRL.ERREO) enables the corresponding output event. Writing a '0' to this bit disables the corresponding output event.

### 12.5.5 Sleep Mode Operation

In Sleep mode, the PAC is kept enabled if an available bus host (CPU, DMA) is running. The PAC will continue to catch access errors from the module and generate interrupts or events.

## 12.6 Register Summary

Offset	Name	Bit Pos.	7	6	5	4	3	2	1	0	
0x00	WRCTRL	7:0	PERID[7:0]								
		15:8	PERID[15:8]								
		23:16	KEY[7:0]								
		31:24									
0x04	EVCTRL	7:0								ERREO	
0x05 ... 0x07	Reserved										
0x08	INTENCLR	7:0								ERR	
0x09	INTENSET	7:0								ERR	
0x0A ... 0x0F	Reserved										
0x10	INTFLAGAHB	7:0	HPB0	RAMDMACIM	RAMDMAWR	RAMPDPSU	RAMCM4S	SEEPROM	FLASH_ALT	FLASH	
		15:8		QSPI	SDHC1	SDHC0	PUKCC	HPB3	HPB2	HPB1	
		23:16									
		31:24									
0x14	INTFLAGA	7:0	GCLK	SUPC	OSC32KCTRL	OSCCTRL	RSTC	MCLK	PM	PAC	
		15:8	TC1	TC0	SERCOM1	SERCOM0	FREQM	EIC	RTC	WDT	
		23:16									
		31:24									
0x18	INTFLAGB	7:0	EVSYS		DMAC	PORT	CMCC	NVMCTRL	DSU	USB	
		15:8		TC3	TC2	TCC1	TCC0	SERCOM3	SERCOM2		
		23:16									RAMECC
		31:24									
0x1C	INTFLAGC	7:0	PDEC	TC5	TC4	TCC3	TCC2	GMAC	CAN1	CAN0	
		15:8		CCL	QSPI	PUKCC	ICM	TRNG	AES	AC	
		23:16									
		31:24									
0x20	INTFLAGD	7:0	ADC0	TC7	TC6	TCC4	SERCOM7	SERCOM6	SERCOM5	SERCOM4	
		15:8					PCC	I2S	DAC	ADC1	
		23:16									
		31:24									
0x24 ... 0x33	Reserved										
0x34	STATUSA	7:0	GCLK	SUPC	OSC32KCTRL	OSCCTRL	RSTC	MCLK	PM	PAC	
		15:8	TC1	TC0	SERCOM1	SERCOM0	FREQM	EIC	RTC	WDT	
		23:16									
		31:24									
0x38	STATUSB	7:0	EVSYS		DMAC	PORT	CMCC	NVMCTRL	DSU	USB	
		15:8		TC3	TC2	TCC1	TCC0	SERCOM3	SERCOM2		
		23:16									RAMECC
		31:24									
0x3C	STATUSC	7:0	PDEC	TC5	TC4	TCC3	TCC2	GMAC	CAN1	CAN0	
		15:8		CCL	QSPI	PUKCC	ICM	TRNG	AES	AC	
		23:16									
		31:24									
0x40	STATUSD	7:0	ADC0	TC7	TC6	TCC4	SERCOM7	SERCOM6	SERCOM5	SERCOM4	
		15:8					PCC	I2S	DAC	ADC1	
		23:16									
		31:24									



## 12.6.1 Write Control

**Name:** WRCTRL  
**Offset:** 0x00  
**Reset:** 0x00000000  
**Property:** -

Bit	31	30	29	28	27	26	25	24
Access								
Reset								
Bit	23	22	21	20	19	18	17	16
	KEY[7:0]							
Access	RW	RW	RW	RW	RW	RW	RW	RW
Reset	0	0	0	0	0	0	0	0
Bit	15	14	13	12	11	10	9	8
	PERID[15:8]							
Access	RW	RW	RW	RW	RW	RW	RW	RW
Reset	0	0	0	0	0	0	0	0
Bit	7	6	5	4	3	2	1	0
	PERID[7:0]							
Access	RW	RW	RW	RW	RW	RW	RW	RW
Reset	0	0	0	0	0	0	0	0

### Bits 23:16 – KEY[7:0] Peripheral Access Control Key

These bits define the peripheral access control key:

Value	Name	Description
0x0	OFF	No action
0x1	CLR	Clear the peripheral write control
0x2	SET	Set the peripheral write control
0x3	SETLCK	Set and lock the peripheral write control until the next hardware reset

### Bits 15:0 – PERID[15:0] Peripheral Identifier

The PERID represents the peripheral whose control is changed using the WRCTRL.KEY. The Peripheral Identifier is calculated following formula:

$$PERID = 32 * BridgeNumber + N$$

Where BridgeNumber represents the Peripheral Bridge Number (0 for Peripheral Bridge A, 1 for Peripheral Bridge B, etc). N represents the peripheral index from the respective Bridge Number, which can be found in the tables of Section 12 Peripheral Configuration Summary in the "PAC, Index" column.

**Table 12-1.** PERID Values

Periph. Bridge Name	BridgeNumber	PERID Values
A	0	0+N
B	1	32+N
C	2	64+N
D	3	96+N

**Notes:**

1. The following peripherals are not supported by the PAC:
  - CAN0, CAN1
  - GMAC
  - ICM
  - PCC
  - SDHC0, SDHC1
2. PORT read/write attempts on non-implemented registers, including addresses beyond the last implemented register group do not generate a PAC protection error.
3. Writing the Frequency Meter Control B register (FREQM.CTRLB) will result in a PAC error.

## 12.6.2 Event Control

**Name:** EVCTRL  
**Offset:** 0x04  
**Reset:** 0x00  
**Property:** -

Bit	7	6	5	4	3	2	1	0
								ERREO
Access								RW
Reset								0

### Bit 0 – ERREO Peripheral Access Error Event Output

This bit indicates if the Peripheral Access Error Event Output is enabled or disabled. When enabled, an event will be generated when one of the interrupt flag registers bits (INTFLAGAHB, INTFLAGn) is set:

Value	Description
0	Peripheral Access Error Event Output is disabled.
1	Peripheral Access Error Event Output is enabled.

### 12.6.3 Interrupt Enable Clear

**Name:** INTENCLR  
**Offset:** 0x08  
**Reset:** 0x00  
**Property:** PAC Write-Protection

This register allows the user to disable an interrupt without doing a read-modify-write operation. Changes in this register will also be reflected in the Interrupt Enable Set register (INTENSET).

Bit	7	6	5	4	3	2	1	0
								ERR
Access								RW
Reset								0

#### Bit 0 – ERR Peripheral Access Error Interrupt Disable

This bit indicates that the Peripheral Access Error Interrupt is enabled and an interrupt request will be generated when one of the interrupt flag registers bits (INTFLAGAHB, INTFLAGn) is set:

Writing a '0' to this bit has no effect.

Writing a '1' to this bit will clear the Peripheral Access Error interrupt Enable bit and disables the corresponding interrupt request.

Value	Description
0	Peripheral Access Error interrupt is disabled.
1	Peripheral Access Error interrupt is enabled.

## 12.6.4 Interrupt Enable Set

**Name:** INTENSET  
**Offset:** 0x09  
**Reset:** 0x00  
**Property:** PAC Write-Protection

This register allows the user to enable an interrupt without doing a read-modify-write operation. Changes in this register will also be reflected in the Interrupt Enable Set register (INTENCLR).

Bit	7	6	5	4	3	2	1	0
								ERR
Access								RW
Reset								0

### Bit 0 – ERR Peripheral Access Error Interrupt Enable

This bit indicates that the Peripheral Access Error Interrupt is enabled and an interrupt request will be generated when one of the interrupt flag registers bits (INTFLAGAHB, INTFLAGn) is set:

Writing a '0' to this bit has no effect.

Writing a '1' to this bit will set the Peripheral Access Error interrupt Enable bit and enables the corresponding interrupt request.

Value	Description
0	Peripheral Access Error interrupt is disabled.
1	Peripheral Access Error interrupt is enabled.

## 12.6.5 Bridge Interrupt Flag Status

**Name:** INTFLAGAHB  
**Offset:** 0x10  
**Reset:** 0x00000000  
**Property:** -

These flags are cleared by writing a '1' to the corresponding bit.

These flags are set when an access error is detected by the corresponding AHB Client, and will generate an interrupt request if INTENCLR/SET.ERR is '1'.

Bit	31	30	29	28	27	26	25	24
Access								
Reset								
Bit	23	22	21	20	19	18	17	16
Access								
Reset								
Bit	15	14	13	12	11	10	9	8
Access		QSPI	SDHC1	SDHC0	PUKCC	HPB3	HPB2	HPB1
Reset		RW	RW	RW	RW	RW	RW	RW
Reset		0	0	0	0	0	0	0
Bit	7	6	5	4	3	2	1	0
Access	HPB0	RAMDMACIC	RAMDMAWR	RAMPPPDSU	RAMCM4S	SEEPROM	FLASH_ALT	FLASH
Reset	RW	RW	RW	RW	RW	RW	RW	RW
Reset	0	0	0	0	0	0	0	0

### Bit 14 – QSPI Interrupt Flag for QSPI

This flag is set when an access error is detected by the QSPI AHB Client, and will generate an interrupt request if INTENCLR/SET.ERR is '1'.

Writing a '0' has no effect.

Writing a '1' to this bit will clear the QSPI interrupt flag.

### Bit 13 – SDHC1 Interrupt Flag for SDHC1

This flag is set when an access error is detected by the SDHC1 AHB Client, and will generate an interrupt request if INTENCLR/SET.ERR is '1'.

Writing a '0' has no effect.

Writing a '1' to this bit will clear the SDHC1 interrupt flag.

### Bit 12 – SDHC0 Interrupt Flag for SDHC0

This flag is set when an access error is detected by the SDHC0 AHB Client, and will generate an interrupt request if INTENCLR/SET.ERR is '1'.

Writing a '0' has no effect.

Writing a '1' to this bit will clear the SDHC0 interrupt flag.

### Bit 11 – PUKCC Interrupt Flag for PUKCC

This flag is set when an access error is detected by the PUKCC AHB Client, and will generate an interrupt request if INTENCLR/SET.ERR is '1'.

Writing a '0' has no effect.

Writing a '1' to this bit will clear the PUKCC interrupt flag.

**Bit 10 – HPB3** Interrupt Flag for AHB-APB Bridge D

This flag is set when an access error is detected by the AHB-APB Bridge D Client, and will generate an interrupt request if INTENCLR/SET.ERR is '1'.

Writing a '0' has no effect.

Writing a '1' to this bit will clear the HPB3 interrupt flag.

**Bit 9 – HPB2** Interrupt Flag for AHB-APB Bridge C

This flag is set when an access error is detected by the AHB-APB Bridge C Client, and will generate an interrupt request if INTENCLR/SET.ERR is '1'.

Writing a '0' has no effect.

Writing a '1' to this bit will clear the HPB2 interrupt flag.

**Bit 8 – HPB1** Interrupt Flag for AHB-APB Bridge B

This flag is set when an access error is detected by the AHB-APB Bridge B Client, and will generate an interrupt request if INTENCLR/SET.ERR is '1'.

Writing a '0' has no effect.

Writing a '1' to this bit will clear the HPB1 interrupt flag.

**Bit 7 – HPB0** Interrupt Flag for AHB-APB Bridge A

This flag is set when an access error is detected by the AHB-APB Bridge A Client, and will generate an interrupt request if INTENCLR/SET.ERR is '1'.

Writing a '0' has no effect.

Writing a '1' to this bit will clear the HPB0 interrupt flag.

**Bit 6 – RAMDMACICM** Interrupt Flag for RAMDMACICM

This flag is set when an access error is detected by the RAMDMACICM AHB Client, and will generate an interrupt request if INTENCLR/SET.ERR is '1'.

Writing a '0' has no effect.

Writing a '1' to this bit will clear the RAMDMACICM interrupt flag.

**Bit 5 – RAMDMAWR** Interrupt Flag for RAMDMAWR

This flag is set when an access error is detected by the RAMDMAWR AHB Client, and will generate an interrupt request if INTENCLR/SET.ERR is '1'.

Writing a '0' has no effect.

Writing a '1' to this bit will clear the RAMDMAWR interrupt flag.

**Bit 4 – RAMPPDSU** Interrupt Flag for RAMPPDSU:

This flag is set when an access error is detected by the RAMPPDSU AHB Client, and will generate an interrupt request if INTENCLR/SET.ERR is '1'.

Writing a '0' has no effect.

Writing a '1' to this bit will clear the RAMPPDSU interrupt flag.

**Bit 3 – RAMCM4S** Interrupt Flag for RAMCM4S

This flag is set when an access error is detected by the RAMCM4S AHB Client, and will generate an interrupt request if INTENCLR/SET.ERR is '1'.

Writing a '0' has no effect.

Writing a '1' to this bit will clear the RAMCM4S interrupt flag.

**Bit 2 – SEEPROM** Interrupt Flag for SEEPROM

This flag is set when an access error is detected by the SEEPROM AHB Client, and will generate an interrupt request if INTENCLR/SET.ERR is '1'.

Writing a '0' has no effect.

Writing a '1' to this bit will clear the SEEPROM interrupt flag.

**Bit 1 – FLASH\_ALT** Interrupt Flag for FLASH\_ALT

This flag is set when an access error is detected by the FLASH\_ALT AHB Client, and will generate an interrupt request if INTENCLR/SET.ERR is '1'.

Writing a '0' has no effect.

Writing a '1' to this bit will clear the FLASH\_ALT interrupt flag.

**Bit 0 – FLASH** Interrupt Flag for FLASH

This flag is set when an access error is detected by the FLASH AHB Client, and will generate an interrupt request if INTENCLR/SET.ERR is '1'.

Writing a '0' has no effect.

Writing a '1' to this bit will clear the FLASH interrupt flag.



## 12.6.6 Peripheral Interrupt Flag Status - Bridge A

**Name:** INTFLAGA  
**Offset:** 0x14  
**Reset:** 0x00000000  
**Property:** -

These flags are set when a Peripheral Access Error occurs while accessing the peripheral associated with the respective INTFLAGx bit, and will generate an interrupt request if INTENCLR/SET.ERR is '1'.

Writing a '0' to these bits has no effect.

Writing a '1' to these bits will clear the corresponding INTFLAGx interrupt flag.

Bit	31	30	29	28	27	26	25	24
Access								
Reset								
Bit	23	22	21	20	19	18	17	16
Access								
Reset								
Bit	15	14	13	12	11	10	9	8
Access	TC1	TC0	SERCOM1	SERCOM0	FREQM	EIC	RTC	WDT
Reset	RW	RW	RW	RW	RW	RW	RW	RW
Reset	0	0	0	0	0	0	0	0
Bit	7	6	5	4	3	2	1	0
Access	GCLK	SUPC	OSC32KCTRL	OSCCTRL	RSTC	MCLK	PM	PAC
Reset	RW	RW	RW	RW	RW	RW	RW	RW
Reset	0	0	0	0	0	0	0	0

### Bit 15 – TC1 Interrupt Flag for TC1

This bit is set when a Peripheral Access Error occurs while accessing the TC1, and will generate an interrupt request if SET.ERR is '1'.

Writing a '0' to this bit has no effect.

Writing a '1' to this bit will clear the flag.

### Bit 14 – TC0 Interrupt Flag for TC0

This bit is set when a Peripheral Access Error occurs while accessing the TC0, and will generate an interrupt request if SET.ERR is '1'.

Writing a '0' to this bit has no effect.

Writing a '1' to this bit will clear the flag.

### Bit 13 – SERCOM1 Interrupt Flag for SERCOM1

This bit is set when a Peripheral Access Error occurs while accessing the SERCOM1, and will generate an interrupt request if SET.ERR is '1'.

Writing a '0' to this bit has no effect.

Writing a '1' to this bit will clear the flag.

### Bit 12 – SERCOM0 Interrupt Flag for SERCOM0

This bit is set when a Peripheral Access Error occurs while accessing the SERCOM0, and will generate an interrupt request if SET.ERR is '1'.

Writing a '0' to this bit has no effect.  
Writing a '1' to this bit will clear the flag.

**Bit 11 – FREQM** Interrupt Flag for FREQM

This bit is set when a Peripheral Access Error occurs while accessing the FREQM, and will generate an interrupt request if SET.ERR is '1'.  
Writing a '0' to this bit has no effect.  
Writing a '1' to this bit will clear the flag.

**Bit 10 – EIC** Interrupt Flag for EIC

This bit is set when a Peripheral Access Error occurs while accessing the EIC, and will generate an interrupt request if SET.ERR is '1'.  
Writing a '0' to this bit has no effect.  
Writing a '1' to this bit will clear the flag.

**Bit 9 – RTC** Interrupt Flag for RTC

This bit is set when a Peripheral Access Error occurs while accessing the RTC, and will generate an interrupt request if SET.ERR is '1'.  
Writing a '0' to this bit has no effect.  
Writing a '1' to this bit will clear the flag.

**Bit 8 – WDT** Interrupt Flag for WDT

This bit is set when a Peripheral Access Error occurs while accessing the WDT, and will generate an interrupt request if SET.ERR is '1'.  
Writing a '0' to this bit has no effect.  
Writing a '1' to this bit will clear the flag.

**Bit 7 – GCLK** Interrupt Flag for GCLK

This bit is set when a Peripheral Access Error occurs while accessing the GCLK, and will generate an interrupt request if SET.ERR is '1'.  
Writing a '0' to this bit has no effect.  
Writing a '1' to this bit will clear the flag.

**Bit 6 – SUPC** Interrupt Flag for SUPC

This bit is set when a Peripheral Access Error occurs while accessing the SUPC, and will generate an interrupt request if SET.ERR is '1'.  
Writing a '0' to this bit has no effect.  
Writing a '1' to this bit will clear the flag.

**Bit 5 – OSC32KCTRL** Interrupt Flag for OSC32KCTRL

This bit is set when a Peripheral Access Error occurs while accessing the OSC32KCTRL, and will generate an interrupt request if SET.ERR is '1'.  
Writing a '0' to this bit has no effect.  
Writing a '1' to this bit will clear the flag.

**Bit 4 – OSCCTRL** Interrupt Flag for OSCCTRL

This bit is set when a Peripheral Access Error occurs while accessing the OSCCTRL, and will generate an interrupt request if SET.ERR is '1'.  
Writing a '0' to this bit has no effect.  
Writing a '1' to this bit will clear the flag.

**Bit 3 – RSTC** Interrupt Flag for RSTC

This bit is set when a Peripheral Access Error occurs while accessing the RSTC, and will generate an interrupt request if SET.ERR is '1'.  
Writing a '0' to this bit has no effect.

Writing a '1' to this bit will clear the flag.

**Bit 2 – MCLK** Interrupt Flag for MCLK

This bit is set when a Peripheral Access Error occurs while accessing the MCLK, and will generate an interrupt request if SET.ERR is '1'.

Writing a '0' to this bit has no effect.

Writing a '1' to this bit will clear the flag.

**Bit 1 – PM** Interrupt Flag for PM

This bit is set when a Peripheral Access Error occurs while accessing the PM, and will generate an interrupt request if SET.ERR is '1'.

Writing a '0' to this bit has no effect.

Writing a '1' to this bit will clear the flag.

**Bit 0 – PAC** Interrupt Flag for PAC

This bit is set when a Peripheral Access Error occurs while accessing the PAC, and will generate an interrupt request if SET.ERR is '1'.

Writing a '0' to this bit has no effect.

Writing a '1' to this bit will clear the flag.

## 12.6.7 Peripheral Interrupt Flag Status - Bridge B

**Name:** INTFLAGB  
**Offset:** 0x18  
**Reset:** 0x00000000  
**Property:** -

These flags are set when a Peripheral Access Error occurs while accessing the peripheral associated with the respective INTFLAGx bit, and will generate an interrupt request if INTENCLR/SET.ERR is '1'.

Writing a '0' to these bits has no effect.

Writing a '1' to these bits will clear the corresponding INTFLAGx interrupt flag.

Bit	31	30	29	28	27	26	25	24
Access								
Reset								
Bit	23	22	21	20	19	18	17	16
Access								RAMECC
Reset								RW 0
Bit	15	14	13	12	11	10	9	8
Access		TC3	TC2	TCC1	TCC0	SERCOM3	SERCOM2	
Reset		RW 0	RW 0	RW 0	RW 0	RW 0	RW 0	
Bit	7	6	5	4	3	2	1	0
Access	EVSYS		DMAC	PORT	CMCC	NVMCTRL	DSU	USB
Reset	RW 0		RW 0	RW 0	RW 0	RW 0	RW 0	RW 0

### Bit 16 - RAMECC Interrupt Flag for RAMECC

This flag is set when a Peripheral Access Error occurs while accessing the RAMECC, and will generate an interrupt request if INTENCLR/SET.ERR is '1'.

Writing a '0' to this bit has no effect.

Writing a '1' to this bit will clear the RAMECC interrupt flag.

### Bit 14 - TC3 Interrupt Flag for TC3

This flag is set when a Peripheral Access Error occurs while accessing the TC3, and will generate an interrupt request if INTENCLR/SET.ERR is '1'.

Writing a '0' to this bit has no effect.

Writing a '1' to this bit will clear the TC3 interrupt flag.

### Bit 13 - TC2 Interrupt Flag for TC2

This flag is set when a Peripheral Access Error occurs while accessing the TC2, and will generate an interrupt request if INTENCLR/SET.ERR is '1'.

Writing a '0' to this bit has no effect.

Writing a '1' to this bit will clear the TC2 interrupt flag.

### Bit 12 - TCC1 Interrupt Flag for TCC1

This flag is set when a Peripheral Access Error occurs while accessing the TCC1, and will generate an interrupt request if INTENCLR/SET.ERR is '1'.

Writing a '0' to this bit has no effect.  
Writing a '1' to this bit will clear the TCC1 interrupt flag.

**Bit 11 – TCC0** Interrupt Flag for TCC0

This flag is set when a Peripheral Access Error occurs while accessing the TCC0, and will generate an interrupt request if INTENCLR/SET.ERR is '1'.  
Writing a '0' to this bit has no effect.  
Writing a '1' to this bit will clear the TCC0 interrupt flag.

**Bit 10 – SERCOM3** Interrupt Flag for SERCOM3

This flag is set when a Peripheral Access Error occurs while accessing the SERCOM3, and will generate an interrupt request if INTENCLR/SET.ERR is '1'.  
Writing a '0' to this bit has no effect.  
Writing a '1' to this bit will clear the SERCOM3 interrupt flag.

**Bit 9 – SERCOM2** Interrupt Flag for SERCOM2

This flag is set when a Peripheral Access Error occurs while accessing the SERCOM2, and will generate an interrupt request if INTENCLR/SET.ERR is '1'.  
Writing a '0' to this bit has no effect.  
Writing a '1' to this bit will clear the SERCOM2 interrupt flag.

**Bit 7 – EVSYS** Interrupt Flag for EVSYS

This flag is set when a Peripheral Access Error occurs while accessing the EVSYS, and will generate an interrupt request if INTENCLR/SET.ERR is '1'.  
Writing a '0' to this bit has no effect.  
Writing a '1' to this bit will clear the EVSYS interrupt flag.

**Bit 5 – DMAC** Interrupt Flag for DMAC

This flag is set when a Peripheral Access Error occurs while accessing the DMAC, and will generate an interrupt request if INTENCLR/SET.ERR is '1'.  
Writing a '0' to this bit has no effect.  
Writing a '1' to this bit will clear the DMAC interrupt flag.

**Bit 4 – PORT** Interrupt Flag for PORT

This flag is set when a Peripheral Access Error occurs while accessing the PORT, and will generate an interrupt request if INTENCLR/SET.ERR is '1'.  
Writing a '0' to this bit has no effect.  
Writing a '1' to this bit will clear the PORT interrupt flag.

**Bit 3 – CMCC** Interrupt Flag for CMCC

This flag is set when a Peripheral Access Error occurs while accessing the CMCC, and will generate an interrupt request if INTENCLR/SET.ERR is '1'.  
Writing a '0' to this bit has no effect.  
Writing a '1' to this bit will clear the CMCC interrupt flag.

**Bit 2 – NVMCTRL** Interrupt Flag for NVMCTRL

This flag is set when a Peripheral Access Error occurs while accessing the NVMCTRL, and will generate an interrupt request if INTENCLR/SET.ERR is '1'.  
Writing a '0' to this bit has no effect.  
Writing a '1' to this bit will clear the NVMCTRL interrupt flag.

**Bit 1 – DSU** Interrupt Flag for DSU

This flag is set when a Peripheral Access Error occurs while accessing the DSU, and will generate an interrupt request if INTENCLR/SET.ERR is '1'.  
Writing a '0' to this bit has no effect.

Writing a '1' to this bit will clear the DSU interrupt flag.

**Bit 0 – USB** Interrupt Flag for USB

This flag is set when a Peripheral Access Error occurs while accessing the USB, and will generate an interrupt request if INTENCLR/SET.ERR is '1'.

Writing a '0' to this bit has no effect.

Writing a '1' to this bit will clear the USB interrupt flag.

## 12.6.8 Peripheral Interrupt Flag Status - Bridge C

**Name:** INTFLAGC  
**Offset:** 0x1C  
**Reset:** 0x00000000  
**Property:** -

These flags are set when a Peripheral Access Error occurs while accessing the peripheral associated with the respective INTFLAGx bit, and will generate an interrupt request if INTENCLR/SET.ERR is '1'.

Writing a '0' to these bits has no effect.

Writing a '1' to these bits will clear the corresponding INTFLAGx interrupt flag.

Bit	31	30	29	28	27	26	25	24
Access								
Reset								
Bit	23	22	21	20	19	18	17	16
Access								
Reset								
Bit	15	14	13	12	11	10	9	8
Access		CCL	QSPI	PUKCC	ICM	TRNG	AES	AC
Reset		RW	RW	RW	RW	RW	RW	RW
		0	0	0	0	0	0	0
Bit	7	6	5	4	3	2	1	0
Access	PDEC	TC5	TC4	TCC3	TCC2	GMAC	CAN1	CAN0
Reset	RW	RW	RW	RW	RW	RW	RW	RW
	0	0	0	0	0	0	0	0

### Bit 14 – CCL Interrupt Flag for CCL

This flag is set when a Peripheral Access Error occurs while accessing the peripheral associated with the CCL, and will generate an interrupt request if INTENCLR/SET.ERR is '1'.

Writing a '0' to this bit has no effect.

Writing a '1' to this bit will clear the CCL interrupt flag.

### Bit 13 – QSPI Interrupt Flag for QSPI

This flag is set when a Peripheral Access Error occurs while accessing the peripheral associated with the QSPI, and will generate an interrupt request if INTENCLR/SET.ERR is '1'.

Writing a '0' to this bit has no effect.

Writing a '1' to this bit will clear the QSPI interrupt flag.

### Bit 12 – PUKCC Interrupt Flag for PUKCC

This flag is set when a Peripheral Access Error occurs while accessing the peripheral associated with the PUKCC, and will generate an interrupt request if INTENCLR/SET.ERR is '1'.

Writing a '0' to this bit has no effect.

Writing a '1' to this bit will clear the PUKCC interrupt flag.

### Bit 11 – ICM Interrupt Flag for ICM

This flag is set when a Peripheral Access Error occurs while accessing the peripheral associated with the ICM, and will generate an interrupt request if INTENCLR/SET.ERR is '1'.

Writing a '0' to this bit has no effect.  
Writing a '1' to this bit will clear the ICM interrupt flag.

**Bit 10 – TRNG** Interrupt Flag for TRNG

This flag is set when a Peripheral Access Error occurs while accessing the peripheral associated with the TRNG, and will generate an interrupt request if INTENCLR/SET.ERR is '1'.  
Writing a '0' to this bit has no effect.  
Writing a '1' to this bit will clear the TRNG interrupt flag.

**Bit 9 – AES** Interrupt Flag for AES

This flag is set when a Peripheral Access Error occurs while accessing the peripheral associated with the AES, and will generate an interrupt request if INTENCLR/SET.ERR is '1'.  
Writing a '0' to this bit has no effect.  
Writing a '1' to this bit will clear the AES interrupt flag.

**Bit 8 – AC** Interrupt Flag for AC

This flag is set when a Peripheral Access Error occurs while accessing the peripheral associated with the AC, and will generate an interrupt request if INTENCLR/SET.ERR is '1'.  
Writing a '0' to this bit has no effect.  
Writing a '1' to this bit will clear the AC interrupt flag.

**Bit 7 – PDEC** Interrupt Flag for PDEC

This flag is set when a Peripheral Access Error occurs while accessing the peripheral associated with the PDEC, and will generate an interrupt request if INTENCLR/SET.ERR is '1'.  
Writing a '0' to this bit has no effect.  
Writing a '1' to this bit will clear the PDEC interrupt flag.

**Bit 6 – TC5** Interrupt Flag for TC5

This flag is set when a Peripheral Access Error occurs while accessing the peripheral associated with the TC5, and will generate an interrupt request if INTENCLR/SET.ERR is '1'.  
Writing a '0' to this bit has no effect.  
Writing a '1' to this bit will clear the TC5 interrupt flag.

**Bit 5 – TC4** Interrupt Flag for TC4

This flag is set when a Peripheral Access Error occurs while accessing the peripheral associated with the TC4, and will generate an interrupt request if INTENCLR/SET.ERR is '1'.  
Writing a '0' to this bit has no effect.  
Writing a '1' to this bit will clear the TC4 interrupt flag.

**Bit 4 – TCC3** Interrupt Flag for TCC3

This flag is set when a Peripheral Access Error occurs while accessing the peripheral associated with the TCC3, and will generate an interrupt request if INTENCLR/SET.ERR is '1'.  
Writing a '0' to this bit has no effect.  
Writing a '1' to this bit will clear the TCC3 interrupt flag.

**Bit 3 – TCC2** Interrupt Flag for TCC2

This flag is set when a Peripheral Access Error occurs while accessing the peripheral associated with the TCC2, and will generate an interrupt request if INTENCLR/SET.ERR is '1'.  
Writing a '0' to this bit has no effect.  
Writing a '1' to this bit will clear the TCC2 interrupt flag.

**Bit 2 – GMAC** Interrupt Flag for GMAC

This flag is set when a Peripheral Access Error occurs while accessing the peripheral associated with the GMAC, and will generate an interrupt request if INTENCLR/SET.ERR is '1'.  
Writing a '0' to this bit has no effect.



Writing a '1' to this bit will clear the GMAC interrupt flag.

**Bit 1 – CAN1** Interrupt Flag for CAN1

This flag is set when a Peripheral Access Error occurs while accessing the peripheral associated with the CAN1, and will generate an interrupt request if INTENCLR/SET.ERR is '1'.

Writing a '0' to this bit has no effect.

Writing a '1' to this bit will clear the CAN1 interrupt flag.

**Bit 0 – CAN0** Interrupt Flag for CAN0

This flag is set when a Peripheral Access Error occurs while accessing the peripheral associated with the CAN0, and will generate an interrupt request if INTENCLR/SET.ERR is '1'.

Writing a '0' to this bit has no effect.

Writing a '1' to this bit will clear the CAN0 interrupt flag.

## 12.6.9 Peripheral Interrupt Flag Status - Bridge D

**Name:** INTFLAGD  
**Offset:** 0x20  
**Reset:** 0x00000000  
**Property:** -

These flags are set when a Peripheral Access Error occurs while accessing the peripheral associated with the respective INTFLAGx bit, and will generate an interrupt request if INTENCLR/SET.ERR is '1'.

Writing a '0' to these bits has no effect.

Writing a '1' to these bits will clear the corresponding INTFLAGx interrupt flag.

Bit	31	30	29	28	27	26	25	24
Access								
Reset								
Bit	23	22	21	20	19	18	17	16
Access								
Reset								
Bit	15	14	13	12	11	10	9	8
Access					PCC	I2S	DAC	ADC1
Reset					RW	RW	RW	RW
					0	0	0	0
Bit	7	6	5	4	3	2	1	0
Access	ADC0	TC7	TC6	TCC4	SERCOM7	SERCOM6	SERCOM5	SERCOM4
Reset	RW	RW	RW	RW	RW	RW	RW	RW
	0	0	0	0	0	0	0	0

### Bit 11 – PCC Interrupt Flag for PCC

This flag is set when a Peripheral Access Error occurs while accessing the PCC, and will generate an interrupt request if INTENCLR/SET.ERR is '1'.

Writing a '0' to these bits has no effect.

Writing a '1' to these bits will clear the PCC interrupt flag.

### Bit 10 – I2S Interrupt Flag for I2S

This flag is set when a Peripheral Access Error occurs while accessing the I2S, and will generate an interrupt request if INTENCLR/SET.ERR is '1'.

Writing a '0' to these bits has no effect.

Writing a '1' to these bits will clear the I2S interrupt flag.

### Bit 9 – DAC Interrupt Flag for DAC

This flag is set when a Peripheral Access Error occurs while accessing the DAC, and will generate an interrupt request if INTENCLR/SET.ERR is '1'.

Writing a '0' to these bits has no effect.

Writing a '1' to these bits will clear the DAC interrupt flag.

### Bit 8 – ADC1 Interrupt Flag for ADC1

This flag is set when a Peripheral Access Error occurs while accessing the ADC1, and will generate an interrupt request if INTENCLR/SET.ERR is '1'.

Writing a '0' to these bits has no effect.  
Writing a '1' to these bits will clear the ADC1 interrupt flag.

**Bit 7 – ADC0** Interrupt Flag for ADC0

This flag is set when a Peripheral Access Error occurs while accessing the ADC0, and will generate an interrupt request if INTENCLR/SET.ERR is '1'.  
Writing a '0' to these bits has no effect.  
Writing a '1' to these bits will clear the ADC0 interrupt flag.

**Bit 6 – TC7** Interrupt Flag for TC7

This flag is set when a Peripheral Access Error occurs while accessing the TC6, and will generate an interrupt request if INTENCLR/SET.ERR is '1'.  
Writing a '0' to these bits has no effect.  
Writing a '1' to these bits will clear the TC7 interrupt flag.

**Bit 5 – TC6** Interrupt Flag for TC6

This flag is set when a Peripheral Access Error occurs while accessing the TC6, and will generate an interrupt request if INTENCLR/SET.ERR is '1'.  
Writing a '0' to these bits has no effect.  
Writing a '1' to these bits will clear the TC6 interrupt flag.

**Bit 4 – TCC4** Interrupt Flag for TCC4

This flag is set when a Peripheral Access Error occurs while accessing the TCC4, and will generate an interrupt request if INTENCLR/SET.ERR is '1'.  
Writing a '0' to these bits has no effect.  
Writing a '1' to these bits will clear the TCC4 interrupt flag.

**Bit 3 – SERCOM7** Interrupt Flag for SERCOM7

This flag is set when a Peripheral Access Error occurs while accessing the SERCOM7, and will generate an interrupt request if INTENCLR/SET.ERR is '1'.  
Writing a '0' to these bits has no effect.  
Writing a '1' to these bits will clear the SERCOM7 interrupt flag.

**Bit 2 – SERCOM6** Interrupt Flag for SERCOM6

This flag is set when a Peripheral Access Error occurs while accessing the SERCOM6, and will generate an interrupt request if INTENCLR/SET.ERR is '1'.  
Writing a '0' to these bits has no effect.  
Writing a '1' to these bits will clear the SERCOM6 interrupt flag.

**Bit 1 – SERCOM5** Interrupt Flag for SERCOM5

This flag is set when a Peripheral Access Error occurs while accessing the SERCOM5, and will generate an interrupt request if INTENCLR/SET.ERR is '1'.  
Writing a '0' to these bits has no effect.  
Writing a '1' to these bits will clear the SERCOM5 interrupt flag.

**Bit 0 – SERCOM4** Interrupt Flag for SERCOM4

This flag is set when a Peripheral Access Error occurs while accessing the SERCOM4, and will generate an interrupt request if INTENCLR/SET.ERR is '1'.  
Writing a '0' to these bits has no effect.  
Writing a '1' to these bits will clear the SERCOM4 interrupt flag.

## 12.6.10 Peripheral Write Protection Status A

**Name:** STATUSA  
**Offset:** 0x34  
**Reset:** 0x00010000  
**Property:** PAC Write-Protection

Writing to this register has no effect.

Reading STATUS register returns peripheral write protection status:

Value	Description
0	Peripheral is not write protected.
1	Peripheral is write protected.

Bit	31	30	29	28	27	26	25	24

Access  
Reset

Bit	23	22	21	20	19	18	17	16

Access  
Reset

Bit	15	14	13	12	11	10	9	8
	TC1	TC0	SERCOM1	SERCOM0	FREQM	EIC	RTC	WDT
Access	R	R	R	R	R	R	R	R
Reset	0	0	0	0	0	0	0	0

Bit	7	6	5	4	3	2	1	0
	GCLK	SUPC	OSC32KCTRL	OSCCTRL	RSTC	MCLK	PM	PAC
Access	R	R	R	R	R	R	R	R
Reset	0	0	0	0	0	0	0	0

### Bit 15 – TC1 TC1 APB Protect Enable

Value	Description
0	TC1 is not write protected
1	TC1 is write protected

### Bit 14 – TC0 TC0 APB Protect Enable

Value	Description
0	TC0 is not write protected
1	TC0 is write protected

### Bit 13 – SERCOM1 SERCOM1 APB Protect Enable

Value	Description
0	SERCOM1 is not write protected
1	SERCOM1 is write protected

### Bit 12 – SERCOM0 SERCOM0 APB Protect Enable

Value	Description
0	SERCOM0 is not write protected
1	SERCOM0 is write protected

### Bit 11 – FREQM FREQM APB Protect Enable

Value	Description
0	FREQM is not write protected
1	FREQM is write protected

**Bit 10 – EIC** EIC APB Protect Enable

Value	Description
0	EIC is not write protected
1	EIC is write protected

**Bit 9 – RTC** RTC APB Protect Enable

Value	Description
0	RTC is not write protected
1	RTC is write protected

**Bit 8 – WDT** WDT APB Protect Enable

Value	Description
0	WDT is not write protected
1	WDT is write protected

**Bit 7 – GCLK** GCLK APB Protect Enable

Value	Description
0	GCLK is not write protected
1	GCLK is write protected

**Bit 6 – SUPC** SUPC APB Protect Enable

Value	Description
0	SUPC is not write protected
1	SUPC is write protected

**Bit 5 – OSC32KCTRL** OSC32KCTRL APB Protect Enable

Value	Description
0	OSC32KCTRL is not write protected
1	OSC32KCTRL is write protected

**Bit 4 – OSCCTRL** OSCCTRL APB Protect Enable

Value	Description
0	OSCCTRL is not write protected
1	OSCCTRL is write protected

**Bit 3 – RSTC** RSTC APB Protect Enable

Value	Description
0	RSTC is not write protected
1	RSTC is write protected

**Bit 2 – MCLK** MCLK APB Protect Enable

Value	Description
0	MCLK is not write protected
1	MCLK is write protected

**Bit 1 – PM** PM APB Protect Enable

Value	Description
0	PM is not write protected
1	PM is write protected

**Bit 0 – PAC** PAC APB Protect Enable

Value	Description
0	PAC is not write protected

Value	Description
1	PAC is write protected

## 12.6.11 Peripheral Write Protection Status - Bridge B

**Name:** STATUSB  
**Offset:** 0x38  
**Reset:** 0x00000002  
**Property:** PAC Write-Protection

Writing to this register has no effect.

Reading STATUS register returns peripheral write protection status:

Value	Description
0	Peripheral is not write protected.
1	Peripheral is write protected.

Bit	31	30	29	28	27	26	25	24
Access								
Reset								
Bit	23	22	21	20	19	18	17	16
Access								RAMECC
Reset								R 0
Bit	15	14	13	12	11	10	9	8
Access		TC3	TC2	TCC1	TCC0	SERCOM3	SERCOM2	
Reset		R 0	R 0	R 0	R 0	R 0	R 0	
Bit	7	6	5	4	3	2	1	0
Access	EVSYS		DMAC	PORT	CMCC	NVMCTRL	DSU	USB
Reset	R 0		R 0	R 0	R 0	R 0	R 1	R 0

### Bit 16 – RAMECC RAMECC APB Protect Enable

Value	Description
0	RAMECC peripheral is not write protected
1	RAMECC peripheral is write protected

### Bit 14 – TC3 TC3 APB Protect Enable

Value	Description
0	TC3 peripheral is not write protected
1	TC3 peripheral is write protected

### Bit 13 – TC2 TC2 APB Protect Enable

Value	Description
0	TC2 peripheral is not write protected
1	TC2 peripheral is write protected

### Bit 12 – TCC1 TCC1 APB Protect Enable

Value	Description
0	TCC1 peripheral is not write protected
1	TCC1 peripheral is write protected

### Bit 11 – TCC0 TCC0 APB Protect Enable

Value	Description
0	TCC0 peripheral is not write protected
1	TCC0 peripheral is write protected

**Bit 10 – SERCOM3** SERCOM3 APB Protect Enable

Value	Description
0	SERCOM3 peripheral is not write protected
1	SERCOM3 peripheral is write protected

**Bit 9 – SERCOM2** SERCOM2 APB Protect Enable

Value	Description
0	SERCOM2 peripheral is not write protected
1	SERCOM2 peripheral is write protected

**Bit 7 – EVSYS** EVSYS APB Protect Enable

Value	Description
0	EVSYS peripheral is not write protected
1	EVSYS peripheral is write protected

**Bit 5 – DMAC** DMAC APB Protect Enable

Value	Description
0	DMAC peripheral is not write protected
1	DMAC peripheral is write protected

**Bit 4 – PORT** PORT APB Protect Enable

Value	Description
0	PORT peripheral is not write protected
1	PORT peripheral is write protected

**Bit 3 – CMCC** CMCC APB Protect Enable

Value	Description
0	CMCC peripheral is not write protected
1	CMCC peripheral is write protected

**Bit 2 – NVMCTRL** NVMCTRL APB Protect Enable

Value	Description
0	NVMCTRL peripheral is not write protected
1	NVMCTRL peripheral is write protected

**Bit 1 – DSU** DSU APB Protect Enable

Value	Description
0	DSU peripheral is not write protected
1	DSU peripheral is write protected

**Bit 0 – USB** USB APB Protect Enable

Value	Description
0	USB peripheral is not write protected
1	USB peripheral is write protected



## 12.6.12 Peripheral Write Protection Status - Bridge C

**Name:** STATUSC  
**Offset:** 0x3C  
**Reset:** 0x00000000  
**Property:** PAC Write-Protection

Writing to this register has no effect.

Reading STATUS register returns peripheral write protection status:

Value	Description
0	Peripheral is not write protected.
1	Peripheral is write protected.

Bit	31	30	29	28	27	26	25	24
Access								
Reset								

Bit	23	22	21	20	19	18	17	16
Access								
Reset								

Bit	15	14	13	12	11	10	9	8
Access		CCL	QSPI	PUKCC	ICM	TRNG	AES	AC
Reset		R	R	R	R	R	R	R
Reset		0	0	0	0	0	0	0

Bit	7	6	5	4	3	2	1	0
Access	PDEC	TC5	TC4	TCC3	TCC2	GMAC	CAN1	CAN0
Reset	R	R	R	R	R	R	R	R
Reset	0	0	0	0	0	0	0	0

### Bit 14 - CCL CCL APB Protection Enable

Value	Description
0	Peripheral is not write protected
1	Peripheral is write protected

### Bit 13 - QSPI QSPI APB Protection Enable

Value	Description
0	Peripheral is not write protected
1	Peripheral is write protected

### Bit 12 - PUKCC PUKCC APB Protection Enable

Value	Description
0	Peripheral is not write protected
1	Peripheral is write protected

### Bit 11 - ICM ICM APB Protection Enable

Value	Description
0	Peripheral is not write protected
1	Peripheral is write protected

### Bit 10 - TRNG TRNG APB Protection Enable

Value	Description
0	Peripheral is not write protected
1	Peripheral is write protected

**Bit 9 – AES** AES APB Protection Enable

Value	Description
0	Peripheral is not write protected
1	Peripheral is write protected

**Bit 8 – AC** AC APB Protection Enable

Value	Description
0	Peripheral is not write protected
1	Peripheral is write protected

**Bit 7 – PDEC** PDEC APB Protection Enable

Value	Description
0	Peripheral is not write protected
1	Peripheral is write protected

**Bit 6 – TC5** TC5 APB Protection Enable

Value	Description
0	Peripheral is not write protected
1	Peripheral is write protected

**Bit 5 – TC4** TC4 APB Protection Enable

Value	Description
0	Peripheral is not write protected
1	Peripheral is write protected

**Bit 4 – TCC3** TCC3 APB Protection Enable

Value	Description
0	Peripheral is not write protected
1	Peripheral is write protected

**Bit 3 – TCC2** TCC2 APB Protection Enable

Value	Description
0	Peripheral is not write protected
1	Peripheral is write protected

**Bit 2 – GMAC** GMAC APB Protection Enable

Value	Description
0	Peripheral is not write protected
1	Peripheral is write protected

**Bit 1 – CAN1** CAN1 APB Protection Enable

Value	Description
0	Peripheral is not write protected
1	Peripheral is write protected

**Bit 0 – CAN0** CAN0 APB Protection Enable

Value	Description
0	Peripheral is not write protected
1	Peripheral is write protected

### 12.6.13 Peripheral Write Protection Status - Bridge D

**Name:** STATUSD  
**Offset:** 0x40  
**Reset:** 0x00000000  
**Property:** PAC Write-Protection, Read-Only

Writing to this register has no effect.

Reading STATUS register returns peripheral write protection status:

Value	Description
0	Peripheral is not write protected.
1	Peripheral is write protected.

Bit	31	30	29	28	27	26	25	24

Access  
Reset

Bit	23	22	21	20	19	18	17	16

Access  
Reset

Bit	15	14	13	12	11	10	9	8
					PCC	I2S	DAC	ADC1

Access  
Reset

Bit	7	6	5	4	3	2	1	0
	ADC0	TC7	TC6	TCC4	SERCOM7	SERCOM6	SERCOM5	SERCOM4

Access  
Reset

#### Bit 11 – PCC PCC APB Protect Enable

Value	Description
0	PCC is not write protected
1	PCC is write protected

#### Bit 10 – I2S I2S APB Protect Enable

Value	Description
0	I2S is not write protected
1	I2S is write protected

#### Bit 9 – DAC DAC APB Protect Enable

Value	Description
0	DAC is not write protected
1	DAC is write protected

#### Bit 8 – ADC1 ADC1 APB Protect Enable

Value	Description
0	ADC1 is not write protected
1	ADC1 is write protected

#### Bit 7 – ADC0 ADC0 APB Protect Enable

Value	Description
0	ADC0 is not write protected
1	ADC0 is write protected

**Bit 6 – TC7** TC7 APB Protect Enable

Value	Description
0	TC7 is not write protected
1	TC7 is write protected

**Bit 5 – TC6** TC6 APB Protect Enable

Value	Description
0	TC6 is not write protected
1	TC6 is write protected

**Bit 4 – TCC4** TCC4 APB Protect Enable

Value	Description
0	TCC4 is not write protected
1	TCC4 is write protected

**Bit 3 – SERCOM7** SERCOM7 APB Protect Enable

Value	Description
0	SERCOM7 is not write protected
1	SERCOM7 is write protected

**Bit 2 – SERCOM6** SERCOM6 APB Protect Enable

Value	Description
0	SERCOM6 is not write protected
1	SERCOM6 is write protected

**Bit 1 – SERCOM5** SERCOM5 APB Protect Enable

Value	Description
0	SERCOM5 is not write protected
1	SERCOM5 is write protected

**Bit 0 – SERCOM4** SERCOM4 APB Protect Enable

Value	Description
0	SERCOM4 is not write protected
1	SERCOM4 is write protected

## 13. Device Service Unit (DSU)

### 13.1 Overview

The Device Service Unit (DSU) provides a means of detecting debugger probes. It enables the Arm Debug Access Port (DAP) to have control over multiplexed debug pads and CPU Reset. The DSU also provides system-level services to debug adapters in an Arm debug system. It implements a CoreSight Debug ROM that provides device identification as well as identification of other debug components within the system. Hence, it complies with the ARM Peripheral Identification specification. The DSU also provides system services to applications that need memory testing, as required for IEC60730 Class B compliance, for example. The DSU can be accessed simultaneously by a debugger and the CPU, as it is connected on the High-Speed Bus Matrix. For security reasons, some of the DSU features will be limited or unavailable when the device is protected by the NVMCTRL security bit.

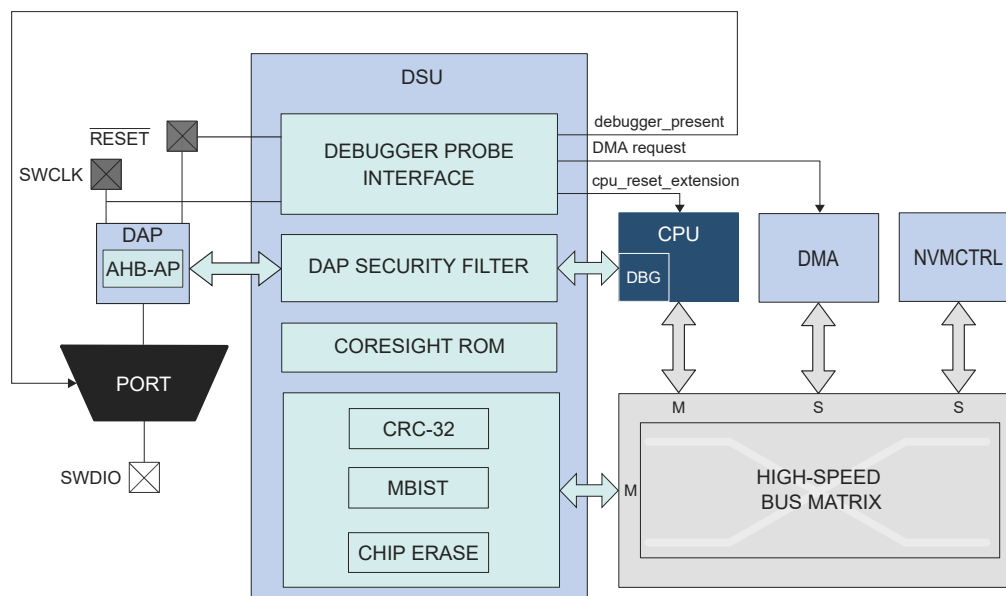
### 13.2 Features

The following are key features of the Device Service Unit (DSU):

- CPU Reset Extension
- Debugger Probe Detection (Cold- and Hot-Plugging)
- Chip-Erase Command and Status
- 32-Bit Cyclic Redundancy Check (CRC32) of any Memory Accessible through the Bus Matrix
- Arm® CoreSight™ Compliant Device Identification
- Two Debug Communications Channels with DMA Connection
- Debug Access Port Security Filter
- Onboard Memory Built-in Self-test (MBIST)

### 13.3 Block Diagram

Figure 13-1. DSU Block Diagram



### 13.4 Signal Description

The DSU uses three signals to function.

Signal Name	Type	Description
RESET	Digital Input	External Reset (RESET pin)
SWCLK	Digital Input	SW clock pin
SWDIO	Digital I/O	SW bidirectional data pin

## 13.5 Peripheral Dependencies

<b>Peripheral Name</b>	DSU - Device Service Unit
<b>Base Address</b>	0x4100_2000 (Peripheral Bus B)
<b>MCLK APB Clock (1)</b>	CLK_DSU_AHB, Enabled, AHBMASK.DSU
<b>GCLK Peripheral Channel Index:Clock Name</b>	n/a
<b>PAC Peripheral Identifier (PAC.WRCTRL)</b>	33
<b>DMA Trigger Index:Source (DMAC.CHCTRLAk,k=0,1,...31)</b>	2 : DCC0, 0x03 : DCC1
<b>Note:</b>	
1. Clock Name, Default State, Mask Field.	

### 13.5.1 I/O Lines

The SWCLK pin is by default assigned to the DSU module to allow debugger probe detection and to stretch the CPU Reset phase. For more information, refer to [13.6.3. Debugger Probe Detection](#). The Hot-Plugging feature depends on the PORT configuration. If the SWCLK pin function is changed in the port or if the PORT\_MUX is disabled, the Hot-Plugging feature is disabled until a power reset or an external Reset is performed.

### 13.5.2 Power Management

The DSU will continue to operate in Idle mode.

### 13.5.3 Clocks

The DSU bus clocks (CLK\_DSU\_APB and CLK\_DSU\_AHB) can be enabled and disabled by the Main Clock Controller.

### 13.5.4 DMA

The DMA request lines are connected to the DMA Controller (DMAC). In order to use DMA requests with this peripheral the DMAC must be configured first. Refer to [DMAC – Direct Memory Access Controller](#) for details.

### 13.5.5 Register Access Protection

Registers with write access can be optionally write-protected by the Peripheral Access Controller (PAC), except for the following:

- Debug Communication Channel 0 register (DCC0)
- Debug Communication Channel 1 register (DCC1)

**Note:** Optional write protection is indicated by the "PAC Write Protection" property in the register description.

Write protection does not apply for accesses through an external debugger.

## 13.6 Debug Operation

### 13.6.1 Principle of Operation

The DSU provides basic services to allow on-chip debug using the Arm Debug Access Port and the Arm processor debug resources:

- CPU Reset extension

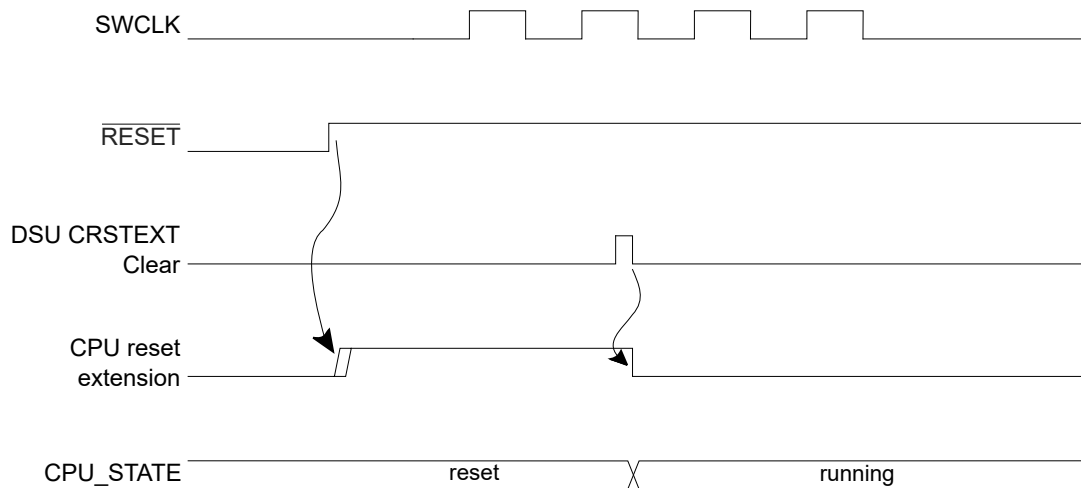
- Debugger probe detection

For more details on the Arm debug components, refer to the Arm “Debug Interface v5 Architecture Specification”.

### 13.6.2 CPU Reset Extension

CPU Reset extension refers to the extension of the Reset phase of the CPU core after the external Reset is released. This ensures that the CPU is not executing code at start-up while a debugger is connects to the system. The debugger is detected on a RESET release event when SWCLK is low. At start-up, SWCLK is internally pulled up to avoid false detection of a debugger if the SWCLK pin is left unconnected. When the CPU is held in the Reset extension phase, the CPU Reset Extension bit of the Status A register (STATUSA.CRSTEXT) is set. To release the CPU, write a '1' to STATUSA.CRSTEXT. STATUSA.CRSTEXT will then be set to '0'. Writing a '0' to STATUSA.CRSTEXT has no effect. For security reasons, it is not possible to release the CPU Reset extension when the device is protected by the NVMCTRL security bit (See NVMCTRL.CTRLB.COMD's Set Security Bit (SSB) command.). Trying to do so sets the Protection Error bit (PERR) of the Status A register (STATUSA.PERR).

**Figure 13-2.** Typical CPU Reset Extension Set and Clear Timing Diagram



### 13.6.3 Debugger Probe Detection

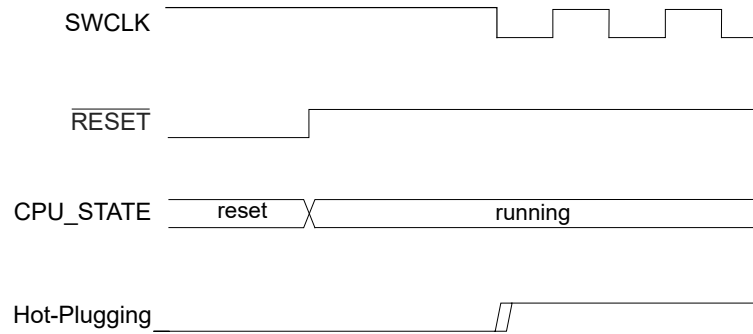
#### 13.6.3.1 Cold-Plugging

Cold-Plugging is the detection of a debugger when the system is in Reset. Cold-Plugging is detected when the CPU Reset extension is requested, as described above.

#### 13.6.3.2 Hot-Plugging

Hot-Plugging is the detection of a debugger probe when the system is not in Reset. Hot-Plugging is not possible under Reset because the detector is reset when POR or RESET are asserted. Hot-Plugging is active when a SWCLK falling edge is detected. The SWCLK pad is multiplexed with other functions and the user must ensure that its default function is assigned to the debug system. If the SWCLK function is changed, the Hot-Plugging feature is disabled until a power reset or external Reset occurs. Availability of the Hot-Plugging feature can be read from the Hot-Plugging Enable bit of the Status B register (STATUSB.HPE).

**Figure 13-3.** Hot-Plugging Detection Timing Diagram



The presence of a debugger probe is detected when either Hot-Plugging or Cold-Plugging is detected. Once detected, the Debugger Present bit of the Status B register (STATUSB.DBGPRES) is set. For security reasons, Hot-Plugging is not available when the device is protected by the NVMCTRL security bit.

This detection requires that pads are correctly powered. Thus, at cold start-up, this detection cannot be done until POR is released. If the device is protected, Cold-Plugging is the only way to detect a debugger probe, and so the external Reset timing must be longer than the POR timing. If external Reset is deasserted before POR release, the user must retry the procedure above until it gets connected to the device.

## 13.7 Chip Erase

Chip erase consists of removing all sensitive information stored in the chip and clearing the NVMCTRL security bit. Therefore, all volatile memories and the Flash memory (including the Smart EEPROM emulation area) will be erased.



**Important:** The Flash auxiliary rows (including the user row), and the BOOTPROT section will not be erased.

When the device is protected, the debugger must first reset the device in order to be detected. This ensures that internal registers are reset after the Protected state is removed.

The chip erase operation is triggered by writing a '1' to the chip erase bit in the Control register (CTRL.CE). This command will be discarded if the DSU is protected by the Peripheral Access Controller (PAC) or when the chip erase command is locked (STATUSB.CEHL = 1 or STATUSB.CELCK = 1).

Once issued, the module clears volatile memories prior to erasing the Flash array. To ensure that the chip erase operation is completed, check the Done bit of the Status A register (STATUSA.DONE).

The chip erase operation depends on clocks and power management features that can be altered by the CPU. For that reason, it is recommended to issue a chip erase after a Cold-Plugging procedure to ensure that the device is in a known and Safe state.

The recommended sequence is as follows:

1. Issue the Cold-Plugging procedure (refer to [13.6.3.1. Cold-Plugging](#)). The device then performs these actions:
  - a. Detects the debugger probe.
  - b. Holds the CPU in Reset.
2. Issue the chip erase command by writing a '1' to CTRL.CE. The device then performs these actions:



- a. Clears the system volatile memories.
  - b. Erases the whole Flash array (including the Smart EEPROM emulation area, not including auxiliary rows and BOOTPROT section).
  - c. Erases the lock row, removing the NVMCTRL security bit protection.
3. Check for completion by polling STATUSA.DONE (read as '1' when completed).
  4. Reset the device to let the NVMCTRL update the fuses.

## 13.8 Programming

Programming the Flash or RAM memories is only possible when the device is not protected by the NVMCTRL security bit. The programming procedure is as follows:

1. At power-up,  $\overline{\text{RESET}}$  is driven low by a debugger. The on-chip regulator holds the system in a POR state until the input supply is above the POR threshold, refer to “Power-on Reset (POR) characteristics”. The system continues to be held in this Static state until the internally regulated supplies have reached a safe Operating state.
2. The PM starts, clocks are switched to the slow clock (Core Clock, System Clock, Flash Clock and any Bus Clocks that do not have clock gate control). Internal Resets are maintained due to the external Reset.
3. The debugger maintains a low level on SWCLK.  $\overline{\text{RESET}}$  is released, resulting in a debugger Cold-Plugging procedure.
4. The debugger generates a clock signal on the SWCLK pin, the Debug Access Port (DAP) receives a clock.
5. The CPU remains in Reset due to the Cold-Plugging procedure; meanwhile, the rest of the system is released.
6. A chip erase is issued to ensure that the Flash is fully erased prior to programming.
7. Programming is available through the AHB-AP.
8. After the operation is completed, the chip can be restarted either by asserting  $\overline{\text{RESET}}$  or toggling power. Make sure that the SWCLK pin is high when releasing  $\overline{\text{RESET}}$  to prevent extending the CPU Reset.

## 13.9 Intellectual Property Protection

Intellectual property protection consists of restricting access to internal memories from external tools when the device is protected, and this is accomplished by setting the NVMCTRL security bit. This Protected state can be removed by issuing a chip erase (refer to [13.7. Chip Erase](#)). When the device is protected, read/write accesses using the AHB-AP are limited to the DSU address range and DSU commands are restricted. When issuing a chip erase, sensitive information is erased from volatile memory and Flash.

The DSU implements a security filter that monitors the AHB transactions inside the DAP. If the device is protected, then AHB-AP read/write accesses outside the DSU external address range are discarded, causing an error response that sets the ARM AHB-AP sticky error bits (refer to the ARM Debug Interface v5 Architecture Specification on [www.arm.com](http://www.arm.com)).

The DSU is intended to be accessed either:

- Internally from the CPU, without any limitation, even when the device is protected
- Externally from a debug adapter, with some restrictions when the device is protected

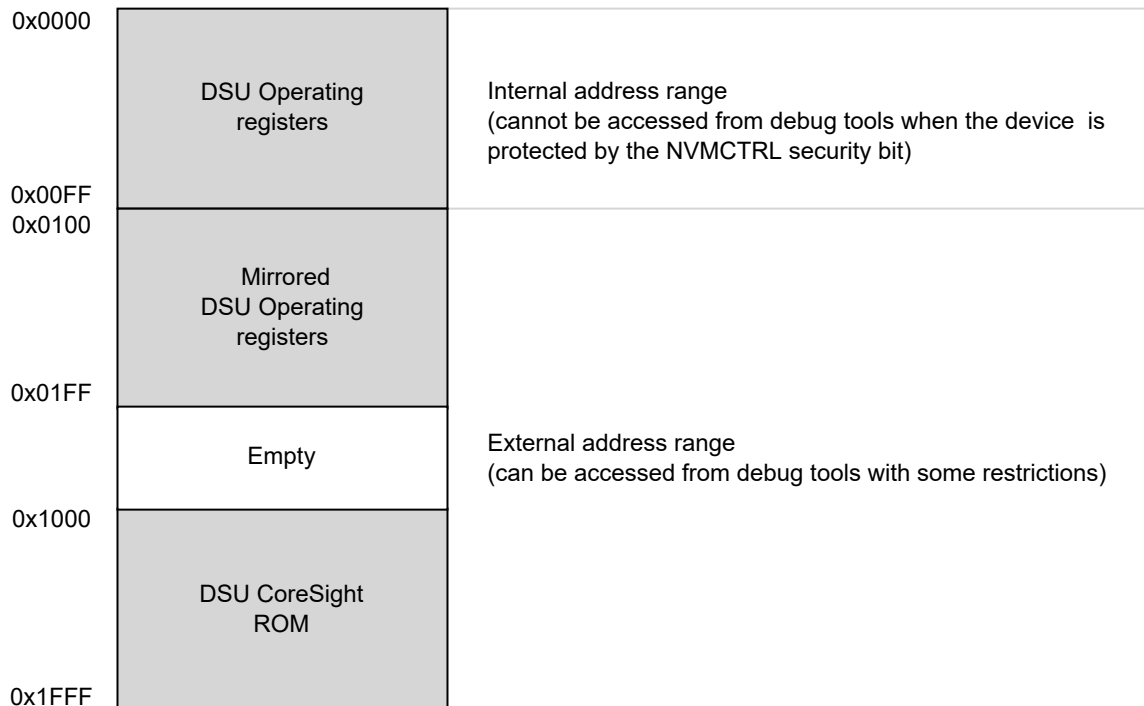
For security reasons, DSU features have limitations when used from a debug adapter. To differentiate external accesses from internal ones, the first 0x100 bytes of the DSU register map has been mirrored at offset 0x100:

- The first 0x100 bytes form the internal address range
- The next 0x100 bytes form the external address range

When the device is protected, the DAP can only issue MEM-AP accesses in the DSU range 0x0100-0x2000.

The DSU Operating registers are located in the 0x0000-0x00FF area and remapped in 0x0100-0x01FF to differentiate accesses coming from a debugger and the CPU. If the device is protected and an access is issued in the region 0x0100-0x01FF, it is subject to security restrictions. For more information, refer to the table “Feature Availability Under Protection”.

**Figure 13-4.** APB Memory Mapping



Some features not activated by APB transactions are not available when the device is protected:

**Table 13-1.** Feature Availability Under Protection

Features	Availability When the Device is Protected
CPU Reset Extension	Yes
Clear CPU Reset Extension	No
Debugger Cold-Plugging	Yes
Debugger Hot-Plugging	No

### 13.10 Device Identification

Device identification relies on the Arm CoreSight component identification scheme, which allows the chip to be identified as a SAM device implementing a DSU. The DSU contains identification registers to differentiate the device.

**Note:** During Coresight discovery (that allows a debugger to identify the available on-chip debug resources), the TPIU and ETB ROM table content (containing component and device IDs) read as 0. Debugger may conclude that TPIU and ETB are unavailable and indicate that trace is not available. A solution to that unexpected behavior is to set the TRCENA bit in the ARM Core Debug Exception and Monitor Control Register (DEMCR) before starting the Coresight discovery process.

### 13.10.1 CoreSight Identification

A system-level Arm® CoreSight™ ROM table is present in the device to identify the vendor and the chip identification method. Its address is provided in the MEM-AP BASE register inside the Arm Debug Access Port. The CoreSight ROM implements a 64-bit conceptual ID composed as follows from the PID0 to PID7 CoreSight ROM Table registers:

Figure 13-5. Conceptual 64-bit Peripheral ID

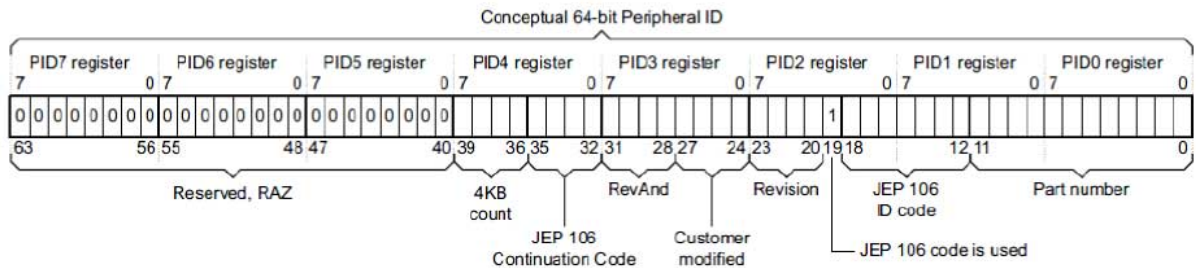


Table 13-2. Conceptual 64-Bit Peripheral ID Bit Descriptions

Field	Size	Description	Location
JEP-106 CC code	4	Continuation code: 0x0	PID4
JEP-106 ID code	7	Device ID: 0x1F	PID1+PID2
4KB count	4	Indicates that the CoreSight component is a ROM: 0x0	PID4
RevAnd	4	Not used; read as 0	PID3
CUSMOD	4	Not used; read as 0	PID3
PARTNUM	12	Contains 0xCD0 to indicate that DSU is present	PID0+PID1
REVISION	4	DSU revision (starts at 0x0 and increments by 1 at both major and minor revisions). Identifies DSU identification method variants. If 0x0, this indicates that device identification can be completed by reading the Device Identification register (DID)	PID2

For more information, refer to the Arm Debug Interface Version 5 Architecture Specification.

### 13.10.2 Chip Identification Method

The DSU DID register identifies the device by implementing the following information:

- Processor identification
- Product family identification
- Product series identification
- Device select

## 13.11 Functional Description

### 13.11.1 Principle of Operation

The DSU provides memory services, such as CRC32 or MBIST that require almost the same interface. Hence, the Address, Length and Data registers (ADDR, LENGTH, DATA) are shared. These shared registers must be configured first; then a command can be issued by writing the Control register. When a command is ongoing, other commands are discarded until the current operation is completed. Hence, the user must wait for the STATUSA.DONE bit to be set prior to issuing another one.

## 13.11.2 Basic Operation

### 13.11.2.1 Initialization

The module is enabled by enabling its clocks. For more details, refer to [13.5.3. Clocks](#). The DSU registers can be PAC write-protected.

### 13.11.2.2 Operation From a Debug Adapter

Debug adapters should access the DSU registers in the external address range 0x100 – 0x2000. If the device is protected by the NVMCTRL security bit, accessing the first 0x100 bytes causes the system to return an error. Refer to [13.9. Intellectual Property Protection](#).

### 13.11.2.3 Operation From the CPU

There are no restrictions when accessing DSU registers from the CPU. However, the user should access DSU registers in the internal address range (0x0 – 0x100) to avoid external security restrictions. Refer to [13.9. Intellectual Property Protection](#).

## 13.11.3 32-bit Cyclic Redundancy Check CRC32

The DSU unit provides support for calculating a cyclic redundancy check (CRC32) value for a memory area (including Flash and AHB RAM).

The algorithm employed is the industry standard CRC32 algorithm using the generator polynomial 0xEDB88320 (reversed representation).

When the CRC32 command is issued from:

- The internal range, the CRC32 can be operated at any memory location
- The external range, the CRC32 operation is restricted; DATA, ADDR, and LENGTH values are forced (see below)

**Table 13-3.** AMOD Bit Descriptions when Operating CRC32

AMOD[1:0]	Short name	External range restrictions
0	ARRAY	CRC32 is restricted to the full Flash array area (Smart EEPROM emulation area not included) DATA forced to 0xFFFFFFFF before calculation (no seed)
1	EEPROM	CRC32 of the whole Smart EEPROM emulation area DATA forced to 0xFFFFFFFF before calculation (no seed)
2-3	Reserved	



**Important:** The NVM Cache must be always enabled when performing a DSU CRC32 request targeting the NVM memory space (ARRAY and EEPROM).

### 13.11.3.1 Starting CRC32 Calculation

CRC32 calculation for a memory range is started after writing the start address into the Address register (ADDR) and the size of the memory range into the Length register (LENGTH). Both must be word-aligned.

The initial value used for the CRC32 calculation must be written to the Data register (DATA). This value will usually be 0xFFFFFFFF, but can be, for example, the result of a previous CRC32 calculation if generating a common CRC32 of separate memory blocks.

Once completed, the calculated CRC32 value can be read out of the Data register. The read value must be complemented to match standard CRC32 implementations or kept non-inverted if used as starting point for subsequent CRC32 calculations.

The actual test is started by writing a '1' in the 32-bit Cyclic Redundancy Check bit of the Control register (CTRL.CRC). A running CRC32 operation can be canceled by resetting the module (writing '1' to CTRL.SWRST).

### 13.11.3.2 Interpreting the Results

The user should monitor the Status A register. When the operation is completed, STATUSA.DONE is set. Then the Bus Error bit of the Status A register (STATUSA.BERR) must be read to ensure that no bus error occurred.

### 13.11.4 Debug Communication Channels

The Debug Communication Channels (DCC0 and DCC1) consist of a pair of registers with associated handshake logic, accessible by both CPU and debugger even if the device is protected by the NVMCTRL security bit. The registers can be used to exchange data between the CPU and the debugger, during run time as well as in Debug mode. This enables the user to build a custom debug protocol using only these registers.

The DCC0 and DCC1 registers are accessible when the Protected state is active. When the device is protected, however, it is not possible to connect a debugger while the CPU is running (STATUSA.CRSTEXT is not writable and the CPU is held under Reset).

Two Debug Communication Channel status bits in the Status B registers (STATUS.DCCDx) indicate whether a new value has been written in DCC0 or DCC1. These bits, DCC0D and DCC1D, are located in the STATUSB registers. They are automatically set on write and cleared on read.

**Note:** The DCC0 and DCC1 registers are shared with the on-board memory testing logic (MBIST). Accordingly, DCC0 and DCC1 must not be used while performing MBIST operations.

### 13.11.5 Debug Communication Channels DMA connection

The DCC0 and DCC1 registers can be used as a source or a destination of a DMA channel. The DSU generates one DMA request per Debug Communication Channels. The level of this DMA request is selectable writing the CFG.DCCDMALEVELx bit. Writing a 0 to this bit will configure the DMA request to trig on DCCx register empty. Writing a 1 to this bit will configure the DMA request to trig on DCCx register full.

### 13.11.6 Testing of On-Board Memories MBIST

The DSU implements a feature for automatic testing of memory, also known as MBIST (memory built-in self test). This is primarily intended for production test of on-board memories. MBIST cannot be operated from the external address range when the device is protected by the NVMCTRL security bit. If an MBIST command is issued when the device is protected, a protection error is reported in the Protection Error bit in the Status A register (STATUSA.PERR).

#### 1. Algorithm

The algorithm used for testing is a type of March algorithm called "March LR". This algorithm is able to detect a wide range of memory defects, while still keeping a linear run time. The algorithm is:

- a. Write entire memory to '0', in any order.
- b. Bit by bit read '0', write '1', in descending order.
- c. Bit by bit read '1', write '0', read '0', write '1', in ascending order.
- d. Bit by bit read '1', write '0', in ascending order.
- e. Bit by bit read '0', write '1', read '1', write '0', in ascending order.
- f. Read '0' from entire memory, in ascending order.

The specific implementation used as a run time which depends on the CPU clock frequency and the number of bytes tested in the RAM. The detected faults are:

- Address decoder faults
- Stuck-at faults
- Transition faults

- Coupling faults
- Linked Coupling faults

## 2. Starting MBIST

To test a memory, you need to write the start address of the memory to the ADDR.ADDR bit field, and the size of the memory into the Length register.

For best test coverage, an entire physical memory block should be tested at once. It is possible to test only a subset of a memory, but the test coverage will then be somewhat lower.

The actual test is started by writing a '1' to CTRL.MBIST. A running MBIST operation can be canceled by writing a '1' to CTRL.SWRST.

## 3. Interpreting the Results

The tester should monitor the STATUSA register. When the operation is completed, STATUSA.DONE is set. There are two different modes:

- ADDR.AMOD = 0: exit-on-error (default)

In this mode, the algorithm terminates either when a fault is detected or on successful completion. In both cases, STATUSA.DONE is set. If an error was detected, STATUSA.FAIL will be set. User then can read the DATA and ADDR registers to locate the fault.

- ADDR.AMOD = 1: pause-on-error

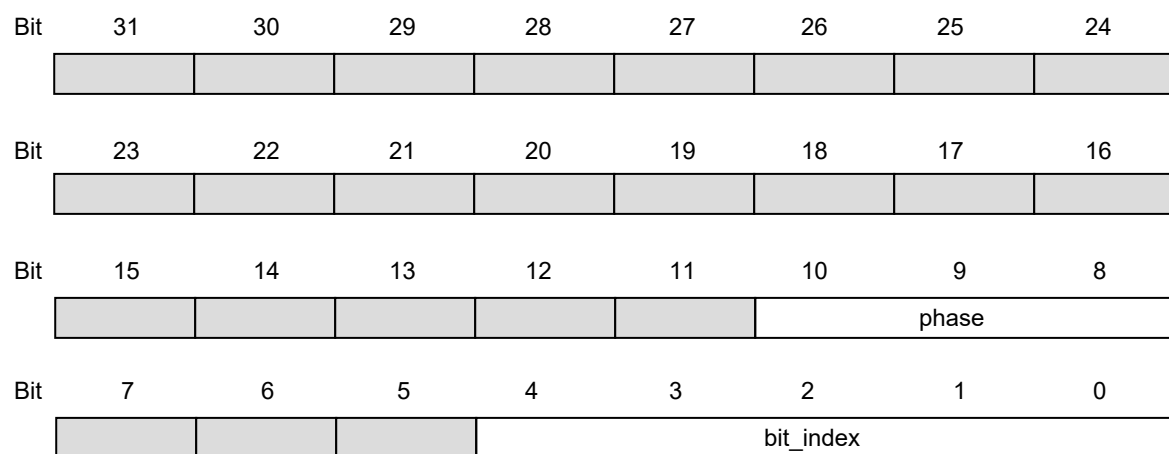
In this mode, the MBIST algorithm is paused when an error is detected. In such a situation, only STATUSA.FAIL is asserted. The state machine waits for user to clear STATUSA.FAIL by writing a '1' in STATUSA.FAIL to resume. Prior to resuming, user can read the DATA and ADDR registers to locate the fault.

## 4. Locating Faults

If the test stops with STATUSA.FAIL set, one or more bits failed the test. The test stops at the first detected error. The position of the failing bit can be found by reading the following registers:

- ADDR: Address of the word containing the failing bit
- DATA: contains data to identify which bit failed, and during which phase of the test it failed. The DATA register will in this case contains the following bit groups:

**Figure 13-6.** DATA bits Description When MBIST Operation Returns an Error



- bit\_index: contains the bit number of the failing bit
- phase: indicates which phase of the test failed and the cause of the error, as listed in the following table.

**Table 13-4. MBIST Operation Phases**

Phase	Test actions
0	Write all bits to zero. This phase cannot fail.
1	Read '0', write '1', increment address
2	Read '1', write '0'
3	Read '0', write '1', decrement address
4	Read '1', write '0', decrement address
5	Read '0', write '1'
6	Read '1', write '0', decrement address
7	Read all zeros. bit_index is not used

**Table 13-5. AMOD Bit Descriptions for MBIST**

AMOD[1:0]	Description
0x0	Exit on Error
0x1	Pause on Error
0x2, 0x3	Reserved

### 13.11.7 System Services Availability when Accessed Externally and Device is Protected

External access: Access performed in the DSU address offset 0x200-0x1FFF range.

Internal access: Access performed in the DSU address offset 0x000-0x100 range.

**Table 13-6. Available Features when Operated From The External Address Range and Device is Protected**

Features	Availability From The External Address Range and Device is Protected
Chip erase command and status	Yes
CRC32	Yes, only full array or full Smart EEPROM
CoreSight Compliant Device identification	Yes
Debug communication channels	Yes
Testing of onboard memories (MBIST)	No
STATUSA.CRSTEXT clearing	No (STATUSA.PERR is set when attempting to do so)

## 13.12 Register Summary

Offset	Name	Bit Pos.	7	6	5	4	3	2	1	0	
0x00	CTRL	7:0				CE	MBIST	CRC		SWRST	
0x01	STATUSA	7:0				PERR	FAIL	BERR	CRSTEXT	DONE	
0x02	STATUSB	7:0		CEHL	CELCK	HPE	DCCD1	DCCD0	DBGPRES	PROT	
0x03	Reserved										
0x04	ADDR	7:0	ADDR[5:0]					AMOD[1:0]			
		15:8					ADDR[13:6]				
		23:16					ADDR[21:14]				
		31:24					ADDR[29:22]				
0x08	LENGTH	7:0	LENGTH[5:0]								
		15:8					LENGTH[13:6]				
		23:16					LENGTH[21:14]				
		31:24					LENGTH[29:22]				
0x0C	DATA	7:0					DATA[7:0]				
		15:8					DATA[15:8]				
		23:16					DATA[23:16]				
		31:24					DATA[31:24]				
0x10	DCC0	7:0					DATA[7:0]				
		15:8					DATA[15:8]				
		23:16					DATA[23:16]				
		31:24					DATA[31:24]				
0x14	DCC1	7:0					DATA[7:0]				
		15:8					DATA[15:8]				
		23:16					DATA[23:16]				
		31:24					DATA[31:24]				
0x18	DID	7:0					DEVSEL[7:0]				
		15:8	DIE[3:0]			REVISION[3:0]					
		23:16	FAMILY[0]				SERIES[5:0]				
		31:24	PROCESSOR[3:0]			FAMILY[4:1]					
0x1C	CFG	7:0					ETBRAMEN	DCCDMALEVEL[1:0]		LQOS[1:0]	
		15:8									
		23:16									
		31:24									
0x20 ... 0xEF	Reserved										
0xF0	DCFG0	7:0					DCFG[7:0]				
		15:8					DCFG[15:8]				
		23:16					DCFG[23:16]				
		31:24					DCFG[31:24]				
0xF4	DCFG1	7:0					DCFG[7:0]				
		15:8					DCFG[15:8]				
		23:16					DCFG[23:16]				
		31:24					DCFG[31:24]				
0xF8 ... 0xFFFF	Reserved										
0x1000	ENTRY0	7:0					FMT		EPRES		
		15:8	ADDOFF[3:0]								
		23:16					ADDOFF[11:4]				
		31:24					ADDOFF[19:12]				
0x1004	ENTRY1	7:0					Reserved		Reserved		
		15:8	Reserved[3:0]								
		23:16					Reserved[11:4]				
		31:24					Reserved[19:12]				
0x1008	END	7:0					END[7:0]				
		15:8					END[15:8]				
		23:16					END[23:16]				
		31:24					END[31:24]				



.....continued

Offset	Name	Bit Pos.	7	6	5	4	3	2	1	0	
0x100C ... 0x1FCB	Reserved										
0x1FCC	MEMTYPE	7:0								SMEMP	
		15:8									
		23:16									
		31:24									
0x1FD0	PID4	7:0	FKBC[3:0]			JEPCC[3:0]					
		15:8									
		23:16									
		31:24									
0x1FD4	PID5	7:0									
		15:8									
		23:16									
		31:24									
0x1FD8	PID6	7:0									
		15:8									
		23:16									
		31:24									
0x1FDC	PID7	7:0									
		15:8									
		23:16									
		31:24									
0x1FE0	PID0	7:0	PARTNBL[7:0]								
		15:8									
		23:16									
		31:24									
0x1FE4	PID1	7:0	JEPIDCL[3:0]			PARTNBH[3:0]					
		15:8									
		23:16									
		31:24									
0x1FE8	PID2	7:0	REVISION[3:0]			JEPU	JEPIDCH[2:0]				
		15:8									
		23:16									
		31:24									
0x1FEC	PID3	7:0	REVAND[3:0]			CUSMOD[3:0]					
		15:8									
		23:16									
		31:24									
0x1FF0	CID0	7:0	PREAMBLEB0[7:0]								
		15:8									
		23:16									
		31:24									
0x1FF4	CID1	7:0	CCLASS[3:0]			PREAMBLE[3:0]					
		15:8									
		23:16									
		31:24									
0x1FF8	CID2	7:0	PREAMBLEB2[7:0]								
		15:8									
		23:16									
		31:24									
0x1FFC	CID3	7:0	PREAMBLEB3[7:0]								
		15:8									
		23:16									
		31:24									

### 13.12.1 Control

**Name:** CTRL  
**Offset:** 0x0000  
**Reset:** 0x00  
**Property:** PAC Write-Protection

Bit	7	6	5	4	3	2	1	0
				CE	MBIST	CRC		SWRST
Access				W	W	W		W
Reset				0	0	0		0

#### Bit 4 – CE Chip-Erase

Writing a '0' to this bit has no effect.  
 Writing a '1' to this bit starts the Chip-Erase operation.

#### Bit 3 – MBIST Memory Built-In Self-Test

Writing a '0' to this bit has no effect.  
 Writing a '1' to this bit starts the memory BIST algorithm.

#### Bit 2 – CRC 32-bit Cyclic Redundancy Check

Writing a '0' to this bit has no effect.  
 Writing a '1' to this bit starts the cyclic redundancy check algorithm.

#### Bit 0 – SWRST Software Reset

Writing a '0' to this bit has no effect.  
 Writing a '1' to this bit resets the module.

## 13.12.2 Status A

**Name:** STATUSA  
**Offset:** 0x0001  
**Reset:** 0x00  
**Property:** PAC Write Protection

Bit	7	6	5	4	3	2	1	0
Access				PERR	FAIL	BERR	CRSTEXT	DONE
Reset				R/W	R/W	R/W	R/W	R/W
				0	0	0	0	0

### Bit 4 – PERR Protection Error

Writing a '0' to this bit has no effect.

Writing a '1' to this bit clears the Protection Error bit.

This bit is set when a command that is not allowed in Protected state is issued.

### Bit 3 – FAIL Failure

Writing a '0' to this bit has no effect.

Writing a '1' to this bit clears the Failure bit.

This bit is set when a DSU operation failure is detected.

### Bit 2 – BERR Bus Error

Writing a '0' to this bit has no effect.

Writing a '1' to this bit clears the Bus Error bit.

This bit is set when a bus error is detected.

### Bit 1 – CRSTEXT CPU Reset Phase Extension

Writing a '0' to this bit has no effect.

Writing a '1' to this bit clears the CPU Reset Phase Extension bit.

This bit is set when a debug adapter Cold-Plugging is detected, which extends the CPU Reset phase.

### Bit 0 – DONE Done

Writing a '0' to this bit has no effect.

Writing a '1' to this bit clears the Done bit.

This bit is set when a DSU operation is completed.

### 13.12.3 Status B

**Name:** STATUSB  
**Offset:** 0x0002  
**Reset:** 0x0x  
**Property:** -

Bit	7	6	5	4	3	2	1	0
		CEHL	CELCK	HPE	DCCD1	DCCD0	DBGPRES	PROT
Access		R	R	R	R	R	R	R
Reset		0	0	0	0	0	x	x

#### Bit 6 – CEHL Chip Erase Hard Locked

Writing a '0' to this bit has no effect.  
Writing a '1' to this bit has no effect.  
This bit is set when Chip Erase is hard locked.



Once set, this bit cannot be cleared and the chip erase command is permanently disabled.

#### Bit 5 – CELCK Chip Erase Locked

Writing a '0' to this bit has no effect.  
Writing a '1' to this bit has no effect.  
This bit is set when Chip Erase is locked.  
This bit is cleared when Chip Erase is unlocked.

#### Bit 4 – HPE Hot-Plugging Enable

Writing a '0' to this bit has no effect.  
Writing a '1' to this bit has no effect.  
This bit is set when Hot-Plugging is enabled.  
This bit is cleared when Hot-Plugging is disabled. This is the case when the SWCLK function is changed. Only a power-reset or a external reset can set it again.

#### Bits 2, 3 – DCCD Debug Communication Channel x Dirty

Writing a '0' to this bit has no effect.  
Writing a '1' to this bit has no effect.  
This bit is set when DCC is written.  
This bit is cleared when DCC is read.

#### Bit 1 – DBGPRES Debugger Present

Writing a '0' to this bit has no effect.  
Writing a '1' to this bit has no effect.  
This bit is set when a debugger probe is detected.  
This bit is never cleared.

#### Bit 0 – PROT Protected

Writing a '0' to this bit has no effect.  
Writing a '1' to this bit has no effect.  
This bit is set at power-up when the device is protected (i.e., the Security Bit is set).  
This bit is reset at power-up when the device is not protected.

### 13.12.4 Address

**Name:** ADDR  
**Offset:** 0x0004  
**Reset:** 0x00000000  
**Property:** PAC Write Protection

Bit	31	30	29	28	27	26	25	24
	ADDR[29:22]							
Access	R/W	R/W	R/W	R/W	R/W	R/W	R/W	R/W
Reset	0	0	0	0	0	0	0	0
Bit	23	22	21	20	19	18	17	16
	ADDR[21:14]							
Access	R/W	R/W	R/W	R/W	R/W	R/W	R/W	R/W
Reset	0	0	0	0	0	0	0	0
Bit	15	14	13	12	11	10	9	8
	ADDR[13:6]							
Access	R/W	R/W	R/W	R/W	R/W	R/W	R/W	R/W
Reset	0	0	0	0	0	0	0	0
Bit	7	6	5	4	3	2	1	0
	ADDR[5:0]						AMOD[1:0]	
Access	R/W	R/W	R/W	R/W	R/W	R/W	R/W	R/W
Reset	0	0	0	0	0	0	0	0

**Bits 31:2 – ADDR[29:0]** Address  
Initial word start address needed for memory operations.

**Bits 1:0 – AMOD[1:0]** Access Mode  
The functionality of these bits is dependent on the operation mode.  
Bit description when operating CRC32: refer to [13.11.3. 32-bit Cyclic Redundancy Check CRC32](#)  
Bit description when testing onboard memories (MBIST): refer to [13.11.6. Testing of On-Board Memories MBIST](#)

### 13.12.5 Length

**Name:** LENGTH  
**Offset:** 0x0008  
**Reset:** 0x00000000  
**Property:** PAC Write Protection

Bit	31	30	29	28	27	26	25	24	
	LENGTH[29:22]								
Access	R/W	R/W	R/W	R/W	R/W	R/W	R/W	R/W	
Reset	0	0	0	0	0	0	0	0	
Bit	23	22	21	20	19	18	17	16	
	LENGTH[21:14]								
Access	R/W	R/W	R/W	R/W	R/W	R/W	R/W	R/W	
Reset	0	0	0	0	0	0	0	0	
Bit	15	14	13	12	11	10	9	8	
	LENGTH[13:6]								
Access	R/W	R/W	R/W	R/W	R/W	R/W	R/W	R/W	
Reset	0	0	0	0	0	0	0	0	
Bit	7	6	5	4	3	2	1	0	
	LENGTH[5:0]								
Access	R/W	R/W	R/W	R/W	R/W	R/W			
Reset	0	0	0	0	0	0			

**Bits 31:2 - LENGTH[29:0]** Length  
 Length in words needed for memory operations.

### 13.12.6 Data

**Name:** DATA  
**Offset:** 0x000C  
**Reset:** 0x00000000  
**Property:** PAC Write Protection

Bit	31	30	29	28	27	26	25	24
	DATA[31:24]							
Access	R/W	R/W	R/W	R/W	R/W	R/W	R/W	R/W
Reset	0	0	0	0	0	0	0	0
Bit	23	22	21	20	19	18	17	16
	DATA[23:16]							
Access	R/W	R/W	R/W	R/W	R/W	R/W	R/W	R/W
Reset	0	0	0	0	0	0	0	0
Bit	15	14	13	12	11	10	9	8
	DATA[15:8]							
Access	R/W	R/W	R/W	R/W	R/W	R/W	R/W	R/W
Reset	0	0	0	0	0	0	0	0
Bit	7	6	5	4	3	2	1	0
	DATA[7:0]							
Access	R/W	R/W	R/W	R/W	R/W	R/W	R/W	R/W
Reset	0	0	0	0	0	0	0	0

**Bits 31:0 – DATA[31:0]** Data  
Memory operation initial value or result value.

### 13.12.7 Debug Communication Channel x

**Name:** DCC  
**Offset:** 0x10 + n\*0x04 [n=0..1]  
**Reset:** 0x00000000  
**Property:** -

Bit	31	30	29	28	27	26	25	24
	DATA[31:24]							
Access	R/W	R/W	R/W	R/W	R/W	R/W	R/W	R/W
Reset	0	0	0	0	0	0	0	0
Bit	23	22	21	20	19	18	17	16
	DATA[23:16]							
Access	R/W	R/W	R/W	R/W	R/W	R/W	R/W	R/W
Reset	0	0	0	0	0	0	0	0
Bit	15	14	13	12	11	10	9	8
	DATA[15:8]							
Access	R/W	R/W	R/W	R/W	R/W	R/W	R/W	R/W
Reset	0	0	0	0	0	0	0	0
Bit	7	6	5	4	3	2	1	0
	DATA[7:0]							
Access	R/W	R/W	R/W	R/W	R/W	R/W	R/W	R/W
Reset	0	0	0	0	0	0	0	0

**Bits 31:0 - DATA[31:0]** Data  
Data register.



## 13.12.8 Device Identification

**Name:** DID  
**Offset:** 0x0018  
**Property:** -

The information in this register is related to the [2. Ordering Information](#).

Bit	31	30	29	28	27	26	25	24
	PROCESSOR[3:0]				FAMILY[4:1]			
Access	R	R	R	R	R	R	R	R
Reset	p	p	p	p	f	f	f	f
Bit	23	22	21	20	19	18	17	16
	FAMILY[0]		SERIES[5:0]					
Access	R		R	R	R	R	R	R
Reset	f		s	s	s	s	s	s
Bit	15	14	13	12	11	10	9	8
	DIE[3:0]				REVISION[3:0]			
Access	R	R	R	R	R	R	R	R
Reset	d	d	d	d	r	r	r	r
Bit	7	6	5	4	3	2	1	0
	DEVSEL[7:0]							
Access	R	R	R	R	R	R	R	R
Reset	x	x	x	x	x	x	x	x

### Bits 31:28 – PROCESSOR[3:0] Processor

The value of this field defines the processor used on the device.

**Note:** For this device, the value of this field is 0x6, corresponding to the Arm Cortex-M4F processor.

### Bits 27:23 – FAMILY[4:0] Product Family

The value of this field corresponds to the product family part of the ordering code.

**Note:** For this device, the value of this field is 0x3, corresponding to the PIC32CX Family of base line microcontrollers.

### Bits 21:16 – SERIES[5:0] Product Series

The value of this field corresponds to the Key Feature Set and Family Variant part of the ordering code.

Value	Description
0x00	PIC32CX SG60
0x01	Reserved
0x02	PIC32CX SG61
0x03-0x06	Reserved
0x07	PIC32CX SG41
0x08-0x3F	Reserved

### Bits 15:12 – DIE[3:0] Die Number

Identifies the die family.

**Note:** For this device, the value of this field is 0x0.

### Bits 11:8 – REVISION[3:0] Revision Number

Identifies the die revision number.

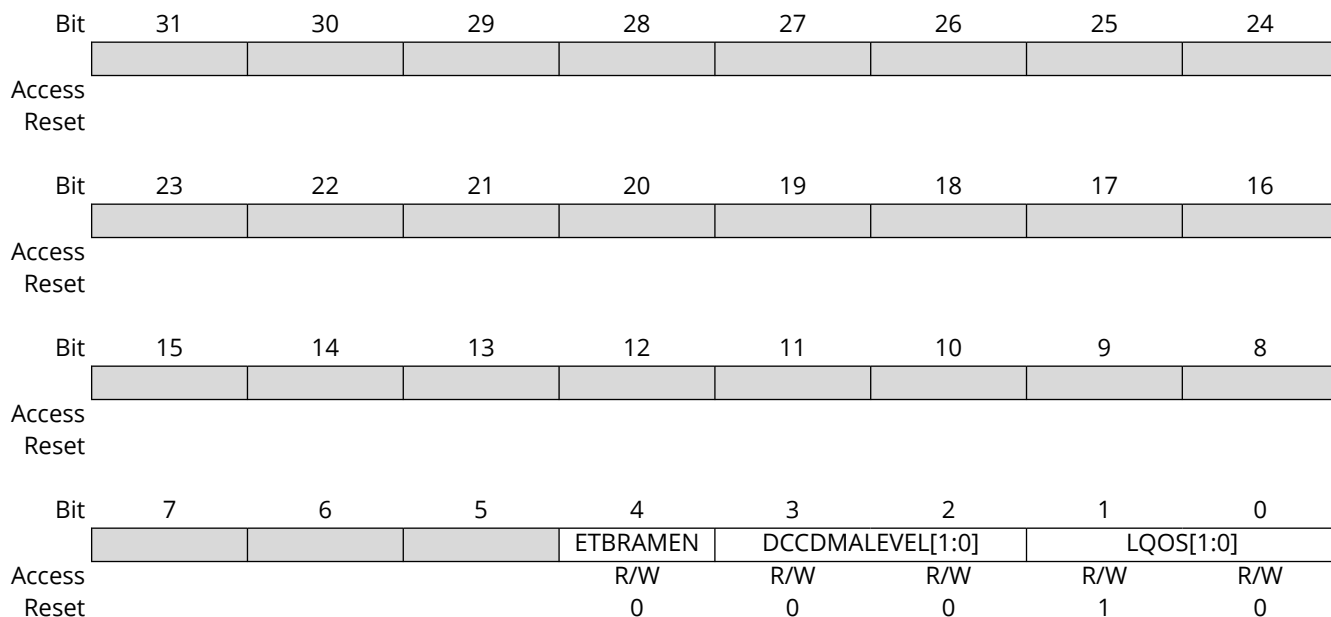
**Bits 7:0 – DEVSEL[7:0]** Device Selection

This bit field identifies a device within a product family and product series. Refer to [2. Ordering Information](#) for device configurations and corresponding values for Flash memory density and pin count.

Value	Description
0x00	1 MB Flash / 256 KB SRAM / 128-pin
0x01	1 MB Flash / 256 KB SRAM / 100-pin
0x04	1 MB Flash / 256 KB SRAM / 64-pin
0x02, 0x03, 0x05 - 0xFF	Reserved

### 13.12.9 Configuration

**Name:** CFG  
**Offset:** 0x1C  
**Reset:** 0x00000002  
**Property:** PAC Write-Protection



#### Bit 4 - ETBRAMEN Trace Control

ETB Ram Enable Writing a one to this bit will reserve the first 32KB of the RAM for the Trace ETB ram buffer. Refer to *Memories / SRAM Memory Configuration* section for details.

#### Bits 3:2 - DCCDMALEVEL[1:0] DMA Trigger Level

Value	Description
0x0	DMA Trigger rises when DCC is empty.
0x1	DMA Trigger rises when DCC is full.
0x2 - 0x3	Reserved

#### Bits 1:0 - LQOS[1:0] Latency Quality Of Service

These bits define the priority access during the memory access. Refer to *SRAM Quality of Service*.

### 13.12.10 Device Configuration

**Name:** DCFG  
**Offset:** 0xF0 + n\*0x04 [n=0..1]  
**Reset:** 0x00000000  
**Property:** PAC Write-Protection

Bit	31	30	29	28	27	26	25	24
	DCFG[31:24]							
Access	R/W	R/W	R/W	R/W	R/W	R/W	R/W	R/W
Reset	0	0	0	0	0	0	0	0
Bit	23	22	21	20	19	18	17	16
	DCFG[23:16]							
Access	R/W	R/W	R/W	R/W	R/W	R/W	R/W	R/W
Reset	0	0	0	0	0	0	0	0
Bit	15	14	13	12	11	10	9	8
	DCFG[15:8]							
Access	R/W	R/W	R/W	R/W	R/W	R/W	R/W	R/W
Reset	0	0	0	0	0	0	0	0
Bit	7	6	5	4	3	2	1	0
	DCFG[7:0]							
Access	R/W	R/W	R/W	R/W	R/W	R/W	R/W	R/W
Reset	0	0	0	0	0	0	0	0

#### Bits 31:0 - DCFG[31:0] Device Configuration

### 13.12.11 CoreSight ROM Table Entry0

**Name:** ENTRY0  
**Offset:** 0x1000  
**Reset:** 0x9F0FC002  
**Property:** -

Bit	31	30	29	28	27	26	25	24
	ADDOFF[19:12]							
Access	R	R	R	R	R	R	R	R
Reset	x	x	x	x	x	x	x	x
Bit	23	22	21	20	19	18	17	16
	ADDOFF[11:4]							
Access	R	R	R	R	R	R	R	R
Reset	x	x	x	x	x	x	x	x
Bit	15	14	13	12	11	10	9	8
	ADDOFF[3:0]							
Access	R	R	R	R				
Reset	x	x	x	x				
Bit	7	6	5	4	3	2	1	0
							FMT	EPRES
Access							R	R
Reset							1	x

#### Bits 31:12 – ADDOFF[19:0] Address Offset

The base address of the component, relative to the base address of this ROM table.

#### Bit 1 – FMT Format

Always reads as '1', indicating a 32-bit ROM table.

#### Bit 0 – EPRES Entry Present

This bit indicates whether an entry is present at this location in the ROM table.

This bit is set at power-up if the device is not protected indicating that the entry is not present.

This bit is cleared at power-up if the device is not protected indicating that the entry is present.

### 13.12.12 CoreSight ROM Table Entry1

**Name:** ENTRY1  
**Offset:** 0x1004  
**Reset:** -  
**Property:** -

Bit	31	30	29	28	27	26	25	24
	Reserved[19:12]							
Access	R	R	R	R	R	R	R	R
Reset	x	x	x	x	x	x	x	x
Bit	23	22	21	20	19	18	17	16
	Reserved[11:4]							
Access	R	R	R	R	R	R	R	R
Reset	x	x	x	x	x	x	x	x
Bit	15	14	13	12	11	10	9	8
	Reserved[3:0]							
Access	R	R	R	R				
Reset	x	x	x	x				
Bit	7	6	5	4	3	2	1	0
							Reserved	Reserved
Access							R	R
Reset							x	x

**Bits 31:12 - Reserved[19:0]**

**Bit 1 - Reserved**

**Bit 0 - Reserved**

### 13.12.13 CoreSight ROM Table End

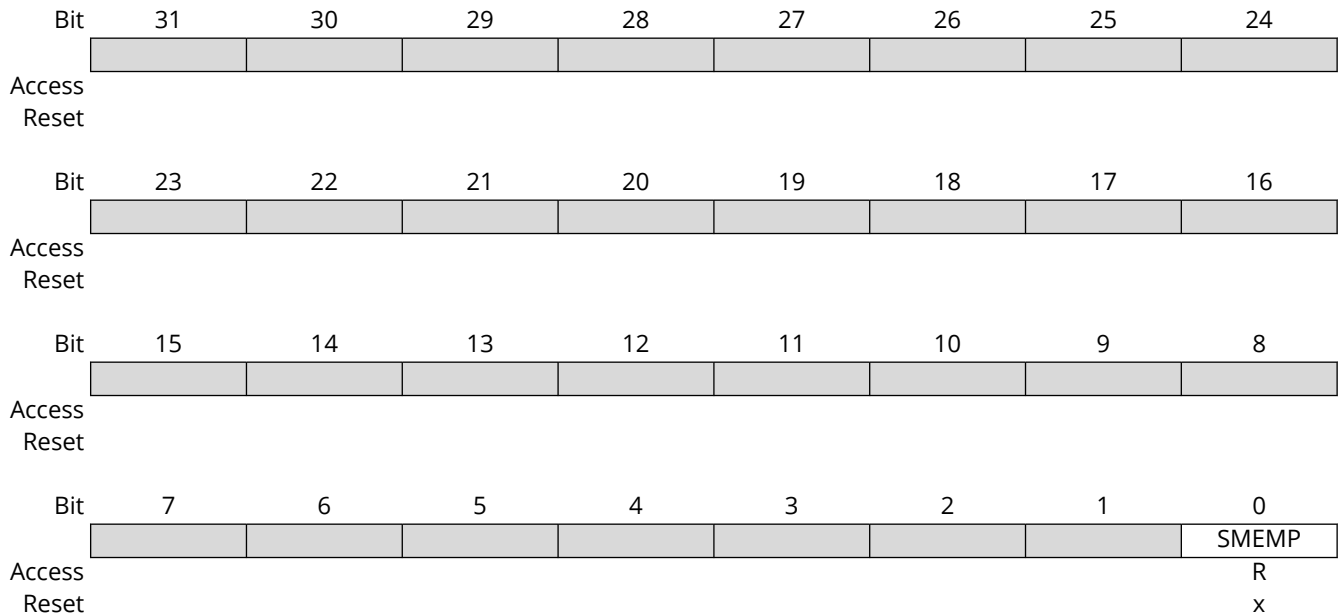
**Name:** END  
**Offset:** 0x1008  
**Reset:** 0x00000000  
**Property:** -

Bit	31	30	29	28	27	26	25	24
	END[31:24]							
Access	R	R	R	R	R	R	R	R
Reset	0	0	0	0	0	0	0	0
Bit	23	22	21	20	19	18	17	16
	END[23:16]							
Access	R	R	R	R	R	R	R	R
Reset	0	0	0	0	0	0	0	0
Bit	15	14	13	12	11	10	9	8
	END[15:8]							
Access	R	R	R	R	R	R	R	R
Reset	0	0	0	0	0	0	0	0
Bit	7	6	5	4	3	2	1	0
	END[7:0]							
Access	R	R	R	R	R	R	R	R
Reset	0	0	0	0	0	0	0	0

**Bits 31:0 – END[31:0]** End Marker  
 Indicates the end of the CoreSight ROM table entries.

### 13.12.14 CoreSight ROM Table Memory Type

**Name:** MEMTYPE  
**Offset:** 0x1FCC  
**Reset:** 0x0000000X  
**Property:** -



#### Bit 0 - SMEMP System Memory Present

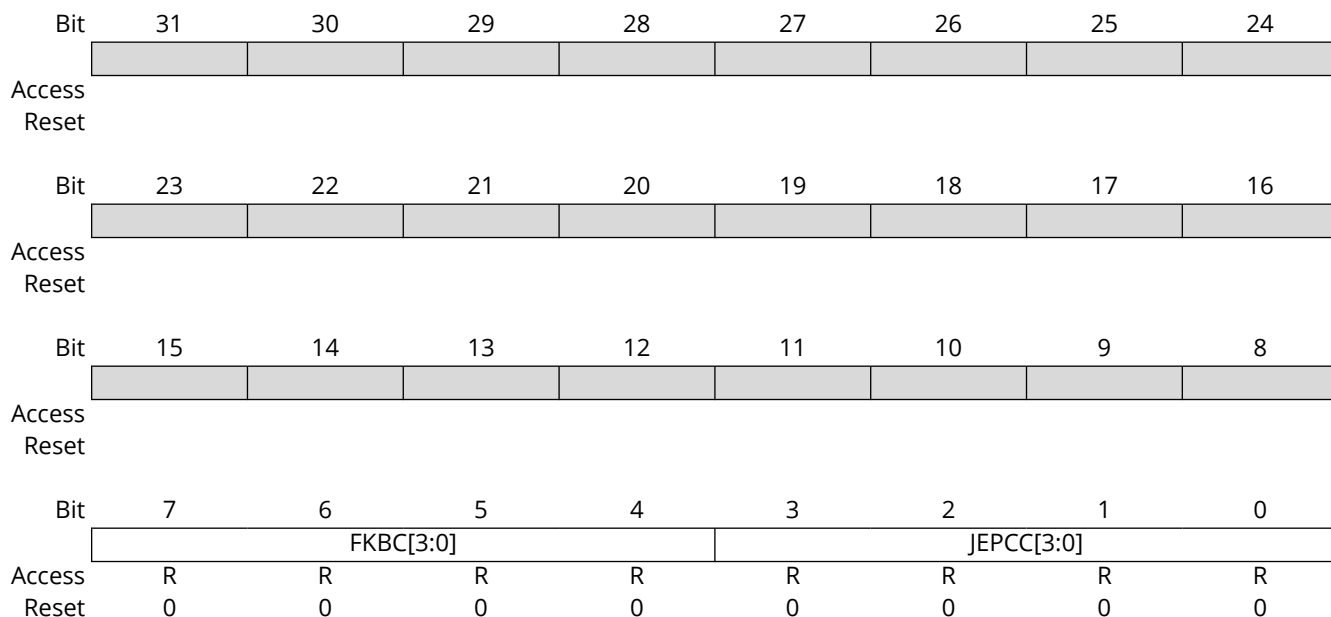
This bit indicates whether system memory is present on the bus that connects to the ROM table. This bit is set at power-up if the device is not protected, indicating that the system memory is accessible from a debug adapter.

This bit is cleared at power-up if the device is protected, indicating that the system memory is not accessible from a debug adapter.



### 13.12.15 Peripheral Identification 4

**Name:** PID4  
**Offset:** 0x1FD0  
**Reset:** 0x00000000  
**Property:** -



**Bits 7:4 – FKBC[3:0]** 4KB Count

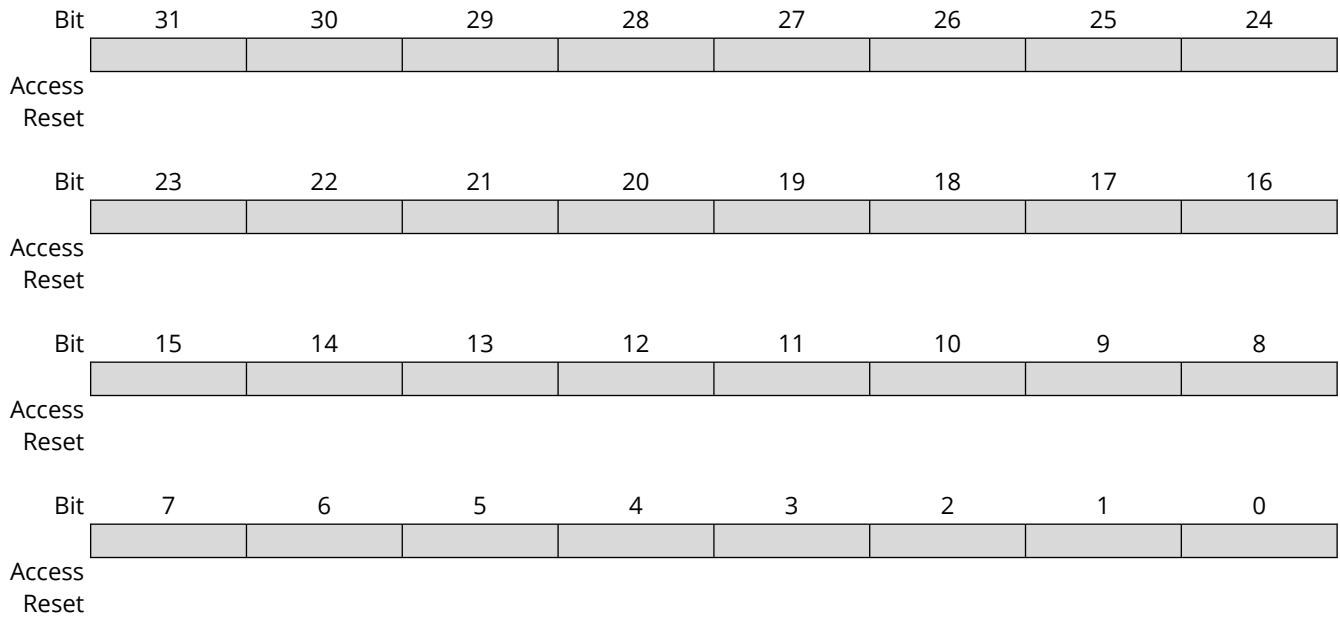
These bits will always return zero when read, indicating that this debug component occupies one 4KB block.

**Bits 3:0 – JEPCC[3:0]** JEP-106 Continuation Code

These bits will always return zero when read.

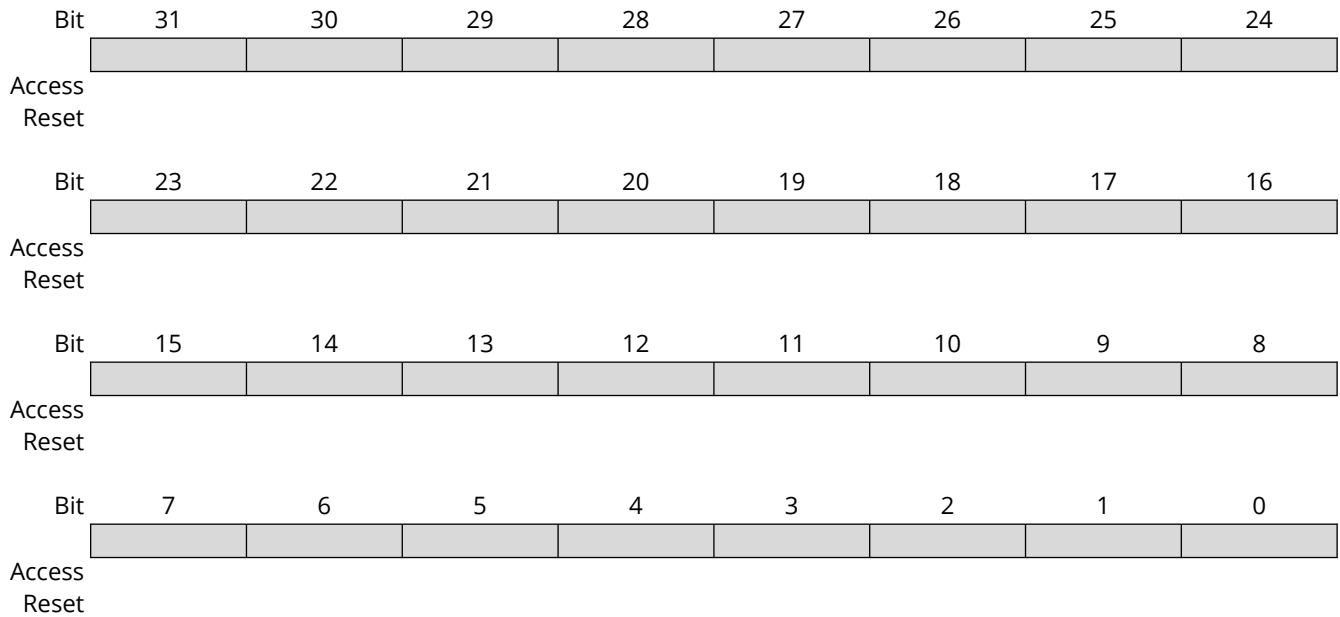
### 13.12.16 Peripheral Identification 7

**Name:** PID7  
**Offset:** 0x1FDC  
**Reset:** 0x00000000  
**Property:** Read-Only



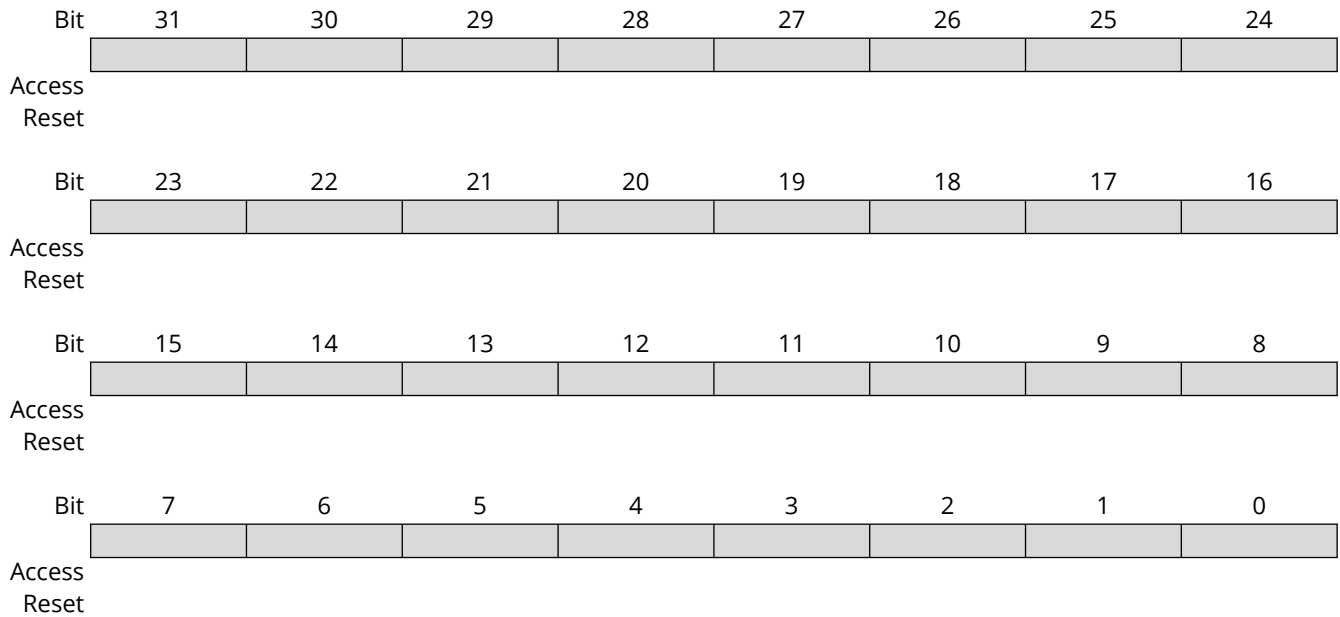
### 13.12.17 Peripheral Identification 6

**Name:** PID6  
**Offset:** 0x1FD8  
**Reset:** 0x00000000  
**Property:** Read-Only



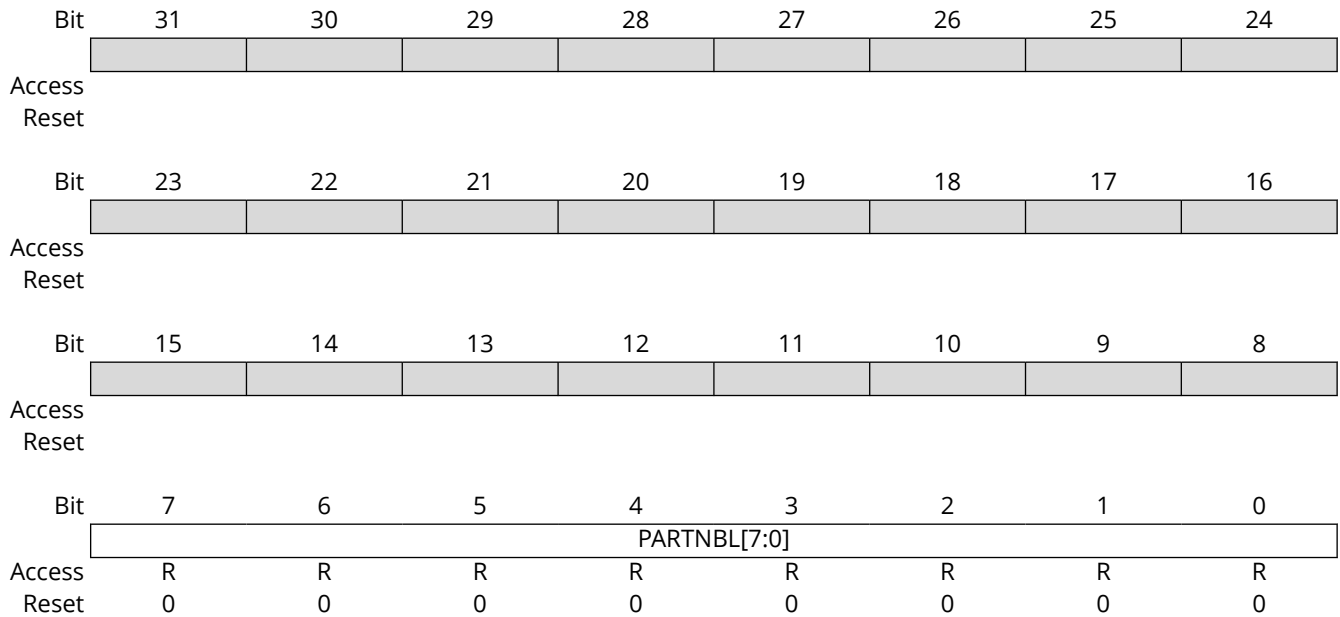
### 13.12.18 Peripheral Identification 5

**Name:** PID5  
**Offset:** 0x1FD4  
**Reset:** 0x00000000  
**Property:** Read-Only



### 13.12.19 Peripheral Identification 0

**Name:** PID0  
**Offset:** 0x1FE0  
**Reset:** 0x000000D0  
**Property:** -

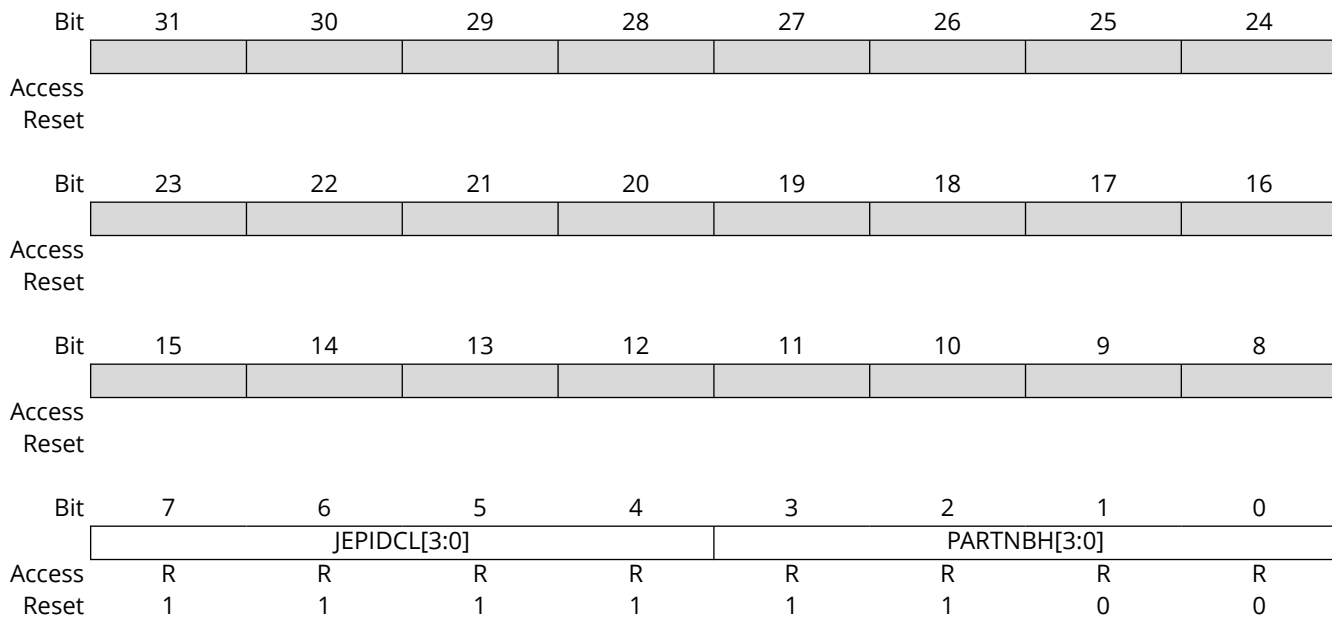


**Bits 7:0 – PARTNBL[7:0] Part Number Low**

These bits will always return 0xD0 when read, indicating that this device implements a DSU module instance.

### 13.12.20 Peripheral Identification 1

**Name:** PID1  
**Offset:** 0x1FE4  
**Reset:** 0x000000FC  
**Property:** -

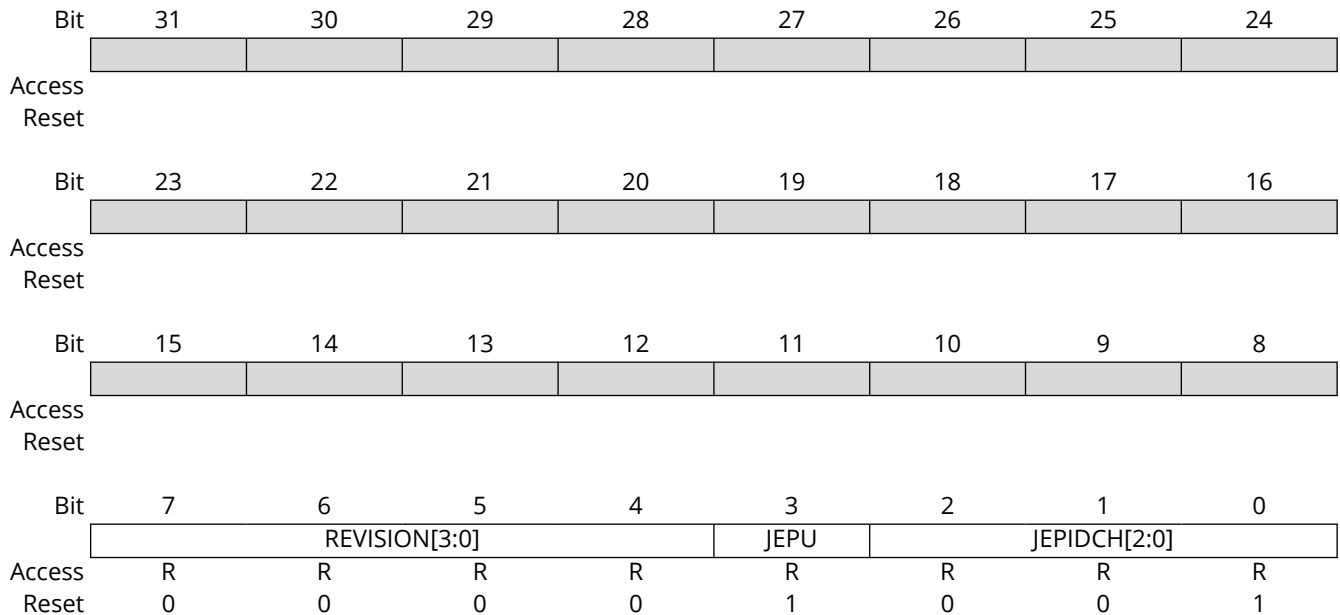


**Bits 7:4 – JEPIDCL[3:0]** Low Part of the JEP-106 Identity Code  
 These bits will always return 0xF when read (JEP-106 identity code is 0x1F).

**Bits 3:0 – PARTNBH[3:0]** Part Number High  
 These bits will always return 0xC when read, indicating that this device implements a DSU module instance.

### 13.12.21 Peripheral Identification 2

**Name:** PID2  
**Offset:** 0x1FE8  
**Reset:** 0x00000009  
**Property:** -



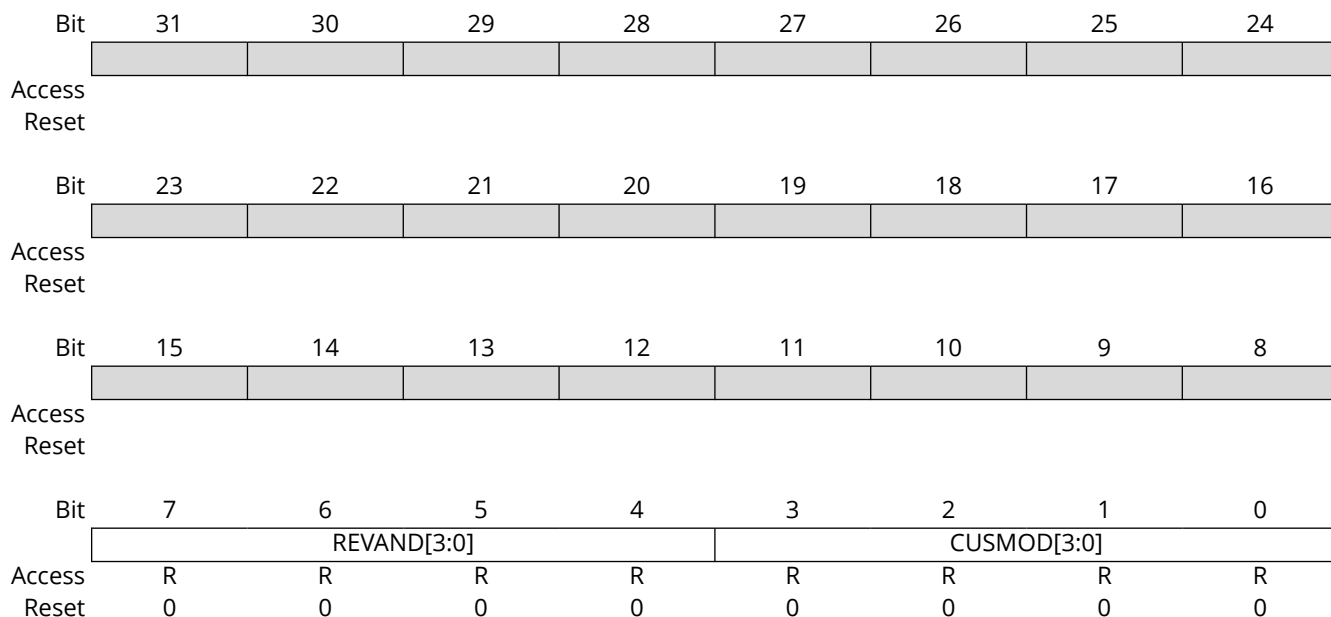
**Bits 7:4 – REVISION[3:0]** Revision Number  
Revision of the peripheral. Starts at 0x0 and increments by one at both major and minor revisions.

**Bit 3 – JEPU** JEP-106 Identity Code is Used  
This bit will always return one when read, indicating that JEP-106 code is used.

**Bits 2:0 – JEPIDCH[2:0]** JEP-106 Identity Code High  
These bits will always return 0x1 when read, (JEP-106 identity code is 0x1F).

### 13.12.22 Peripheral Identification 3

**Name:** PID3  
**Offset:** 0x1FEC  
**Reset:** 0x00000000  
**Property:** -



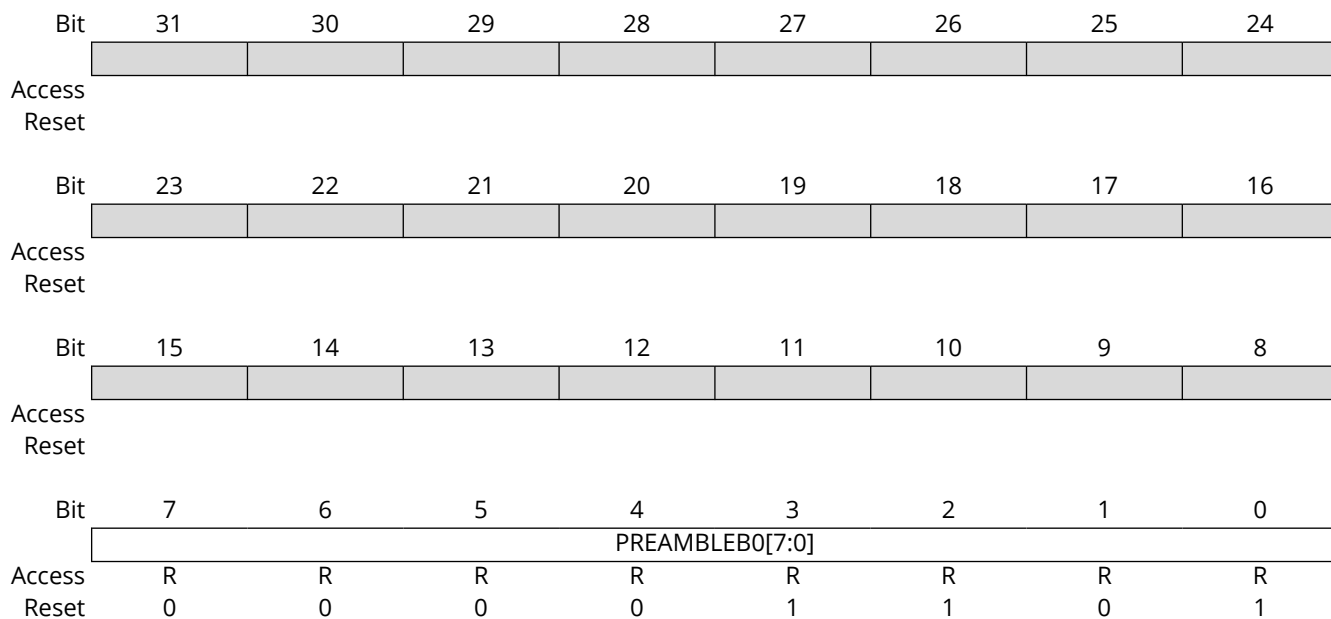
**Bits 7:4 – REVAND[3:0]** Revision Number  
 These bits will always return 0x0 when read.

**Bits 3:0 – CUSMOD[3:0]** ARM CUSMOD  
 These bits will always return 0x0 when read.



### 13.12.23 Component Identification 0

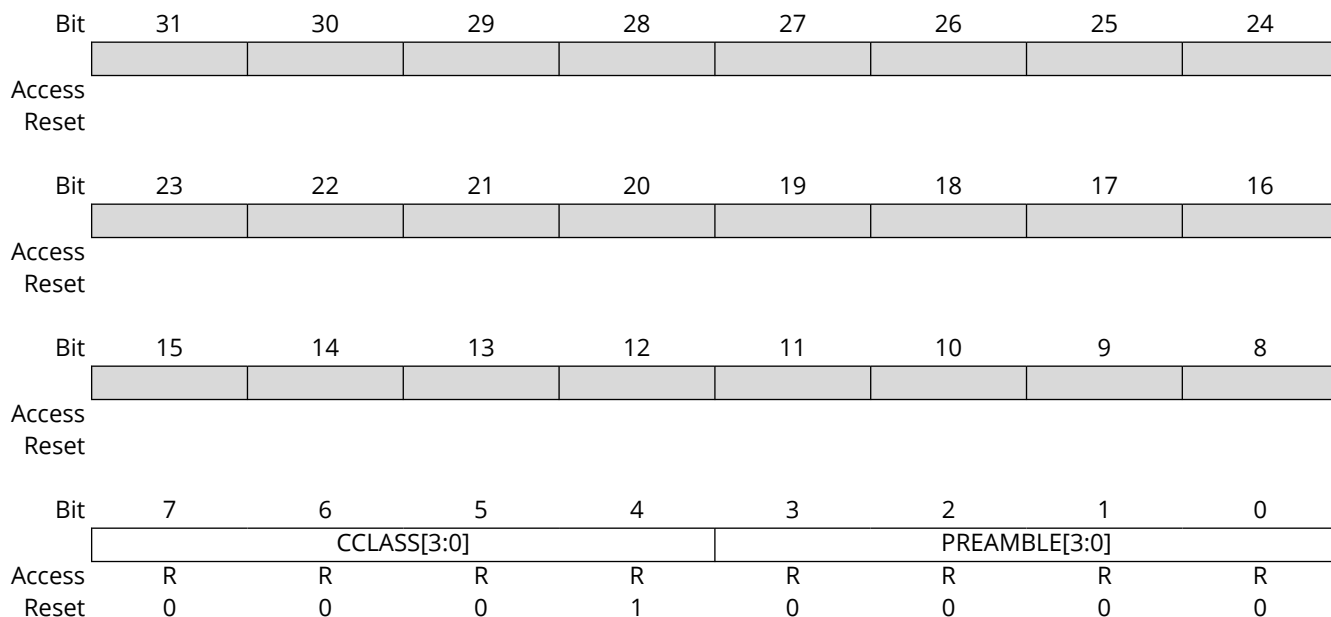
**Name:** CID0  
**Offset:** 0x1FF0  
**Reset:** 0x0000000D  
**Property:** -



**Bits 7:0 – PREAMBLEB0[7:0]** Preamble Byte 0  
 These bits will always return 0x0000000D when read.

### 13.12.24 Component Identification 1

**Name:** CID1  
**Offset:** 0x1FF4  
**Reset:** 0x00000010  
**Property:** -



#### Bits 7:4 - CCLASS[3:0] Component Class

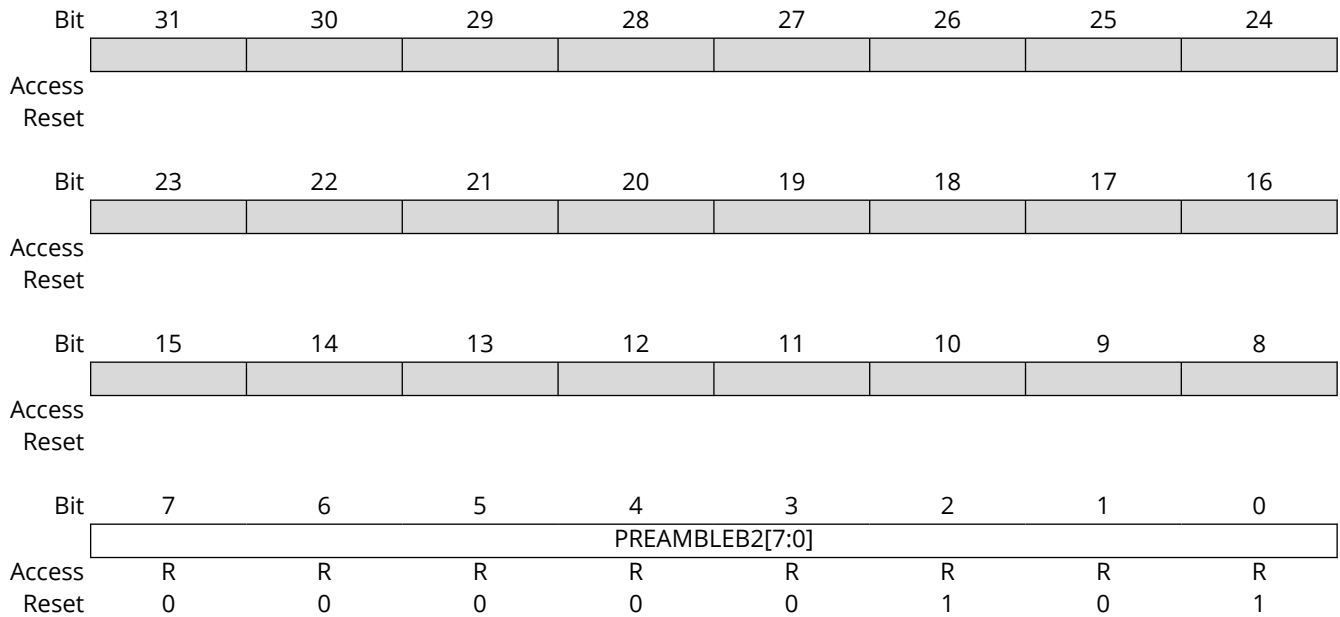
These bits will always return 0x1 when read indicating that this ARM CoreSight component is ROM table (refer to the ARM Debug Interface v5 Architecture Specification at <http://www.arm.com>).

#### Bits 3:0 - PREAMBLE[3:0] Preamble

These bits will always return 0x00 when read.

### 13.12.25 Component Identification 2

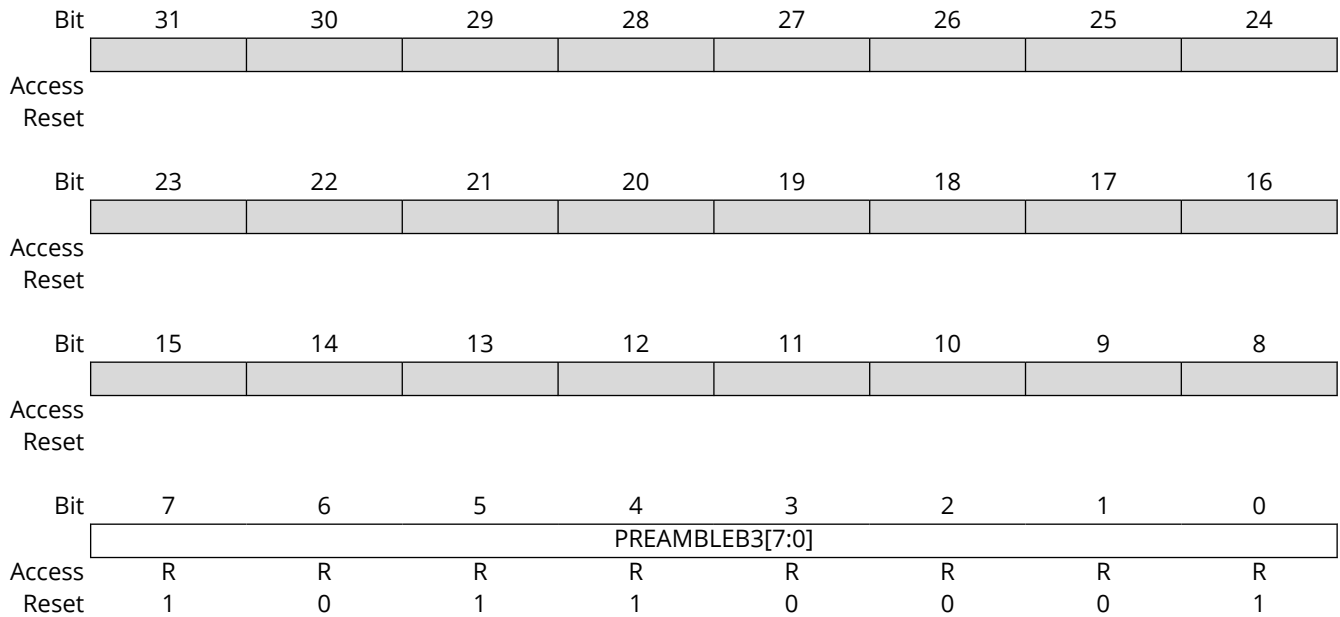
**Name:** CID2  
**Offset:** 0x1FF8  
**Reset:** 0x00000005  
**Property:** -



**Bits 7:0 – PREAMBLEB2[7:0]** Preamble Byte 2  
 These bits will always return 0x00000005 when read.

### 13.12.26 Component Identification 3

**Name:** CID3  
**Offset:** 0x1FFC  
**Reset:** 0x000000B1  
**Property:** -



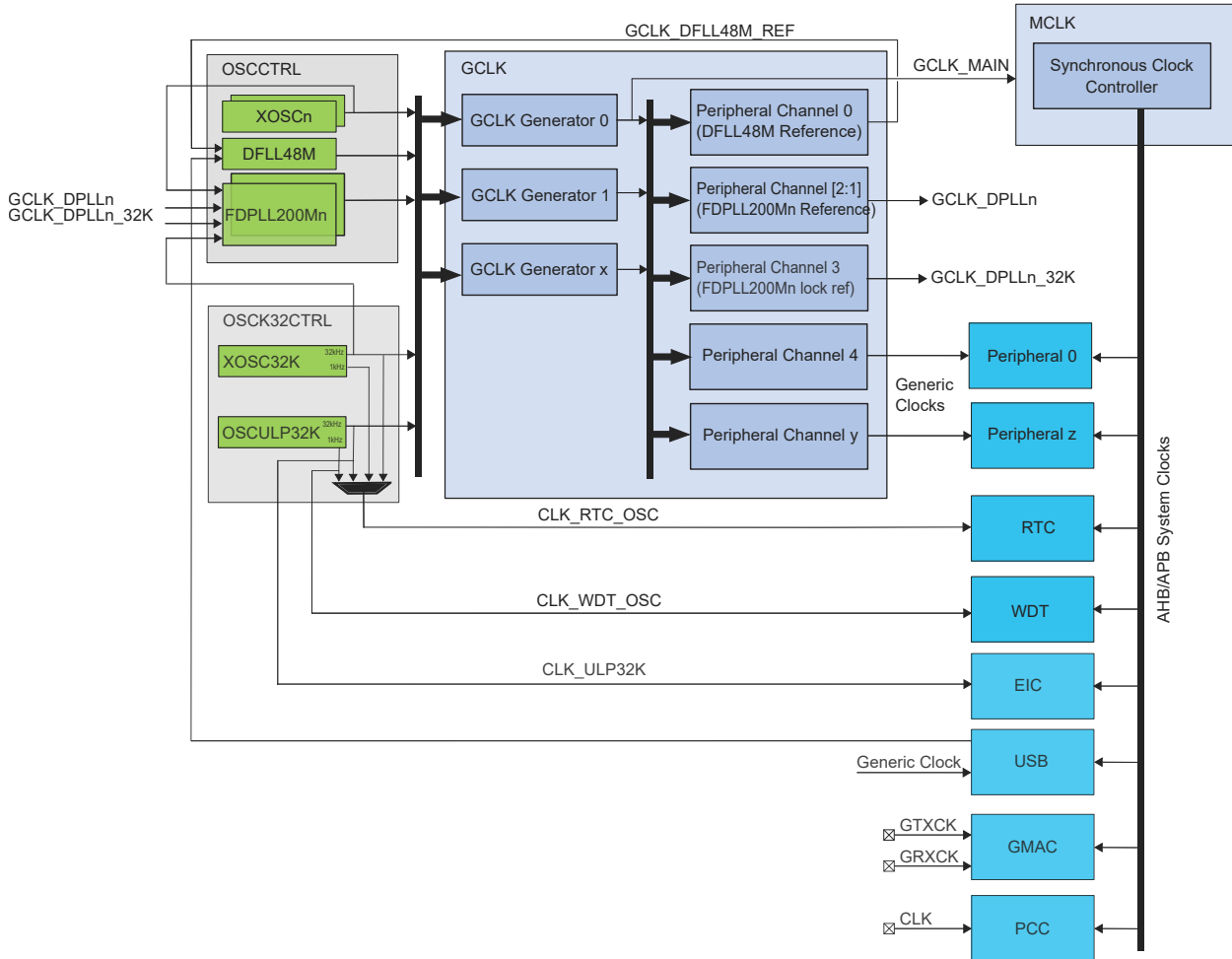
**Bits 7:0 – PREAMBLEB3[7:0]** Preamble Byte 3  
 These bits will always return 0x000000B1 when read.

## 14. Clock System

This chapter summarizes the clock distribution and terminology in the PIC32CX SG41/SG60/SG61 device. It does not explain every detail of its configuration. For in-depth documentation, see the respective peripherals descriptions and the *Generic Clock* documentation.

### 14.1 Clock Distribution

Figure 14-1. Clock Distribution



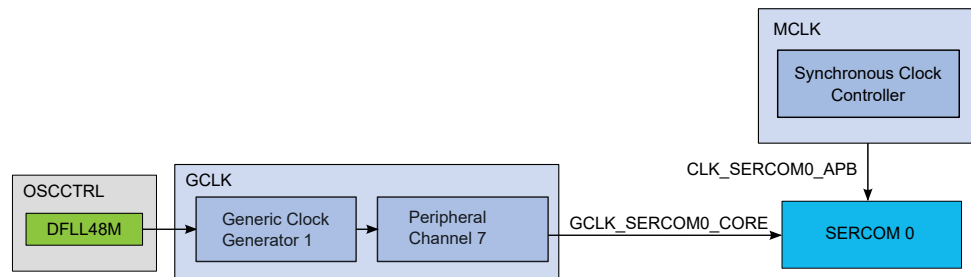
The PIC32CX SG41/SG60/SG61 clock system consists of:

- *Clock sources*, that is, oscillators controlled by OSCCTRL and OSC32KCTRL
  - A clock source provides a time base that is used by other components, such as Generic Clock Generators. Example clock sources are the external crystal oscillator (XOSC0 and XOSC1) and the Digital Frequency Locked Loop (DFLL48M).
- *Generic Clock Controller (GCLK)*, which generates, controls and distributes asynchronous clocks consisting of:
  - *Generic Clock Generators*: These are programmable prescalers that can use any of the system clock sources as a time base. The Generic Clock Generator 0 generates the clock signal GCLK\_MAIN, which is used by the Power Manager and the Main Clock (MCLK) module, which in turn generates synchronous clocks.

- *Generic Clocks:* These are clock signals generated by Generic Clock Generators and output by the Peripheral Channels, and serve as clocks for the peripherals of the system. Multiple instances of a peripheral will typically have a separate Generic Clock for each instance. Generic Clock 0 serves as the clock source for the DFLL48M clock input (when multiplying another clock source).
- *Main Clock Controller (MCLK)*
  - The MCLK generates and controls the synchronous clocks on the system. This includes the CPU, bus clocks (APB, AHB) as well as the synchronous (to the CPU) user interfaces of the peripherals. It contains clock masks that can turn on/off the user interface of a peripheral as well as prescalers for the CPU and bus clocks.

The figure below shows an example where SERCOM0 is clocked by the DFLL48M in open loop mode. The DFLL48M is enabled, the Generic Clock Generator 1 uses the DFLL48M as its clock source and feeds into Peripheral Channel 7. The Generic Clock 7, also called GCLK\_SERCOM0\_CORE, is connected to SERCOM0. The SERCOM0 interface, clocked by CLK\_SERCOM0\_APB, has been unmasked in the APBC Mask register in the MCLK.

**Figure 14-2.** Example of SERCOM Clock



To customize the clock distribution, refer to these registers and bit fields:

- The source oscillator for a Generic Clock Generator  $n$  is selected by writing to the Source bit field in the Generator Control  $n$  register (GCLK.GENCTRL $n$ .SRC).
- A Peripheral Channel  $m$  can be configured to use a specific Generic Clock Generator by writing to the Generic Clock Generator bit field in the respective Peripheral Channel  $m$  register (GCLK.PCHCTRL $m$ .GEN)
- The Peripheral Channel number,  $m$ , is fixed for a given peripheral. See the PCHCTRL $m$  Mapping table in the description of GCLK.PCHCTRL $m$ .
- The AHB clocks are enabled and disabled by writing to the respective bit in the AHB Mask register (MCLK.AHBMASK).
- The APB clocks are enabled and disabled by writing to the respective bit in the APB  $x$  Mask registers (MCLK.APB $x$ MASK).

## 14.2 Synchronous and Asynchronous Clocks

As the CPU and the peripherals can be in different clock domains, i.e. they are clocked from different clock sources and/or with different clock speeds, some peripheral accesses by the CPU need to be synchronized. In this case the peripheral includes a Synchronization Busy (SYNCBUSY) register that can be used to check if a sync operation is in progress.

For a general description, see [14.3. Register Synchronization](#). Some peripherals have specific properties described in their individual sub-chapter “Synchronization”.

In the data sheet, references to Synchronous Clocks are referring to the CPU and bus clocks (MCLK), while asynchronous clocks are generated by the Generic Clock Controller (GCLK).

## 14.3 Register Synchronization

### 14.3.1 Overview

All peripherals are composed of one digital bus interface connected to the APB or AHB bus and running from a corresponding clock in the Main Clock domain, and one peripheral core running from the peripheral Generic Clock (GCLK).

Communication between these clock domains must be synchronized. This mechanism is implemented in hardware, so the synchronization process takes place even if the peripheral generic clock is running from the same clock source and on the same frequency as the bus interface.

All registers in the bus interface are accessible without synchronization.

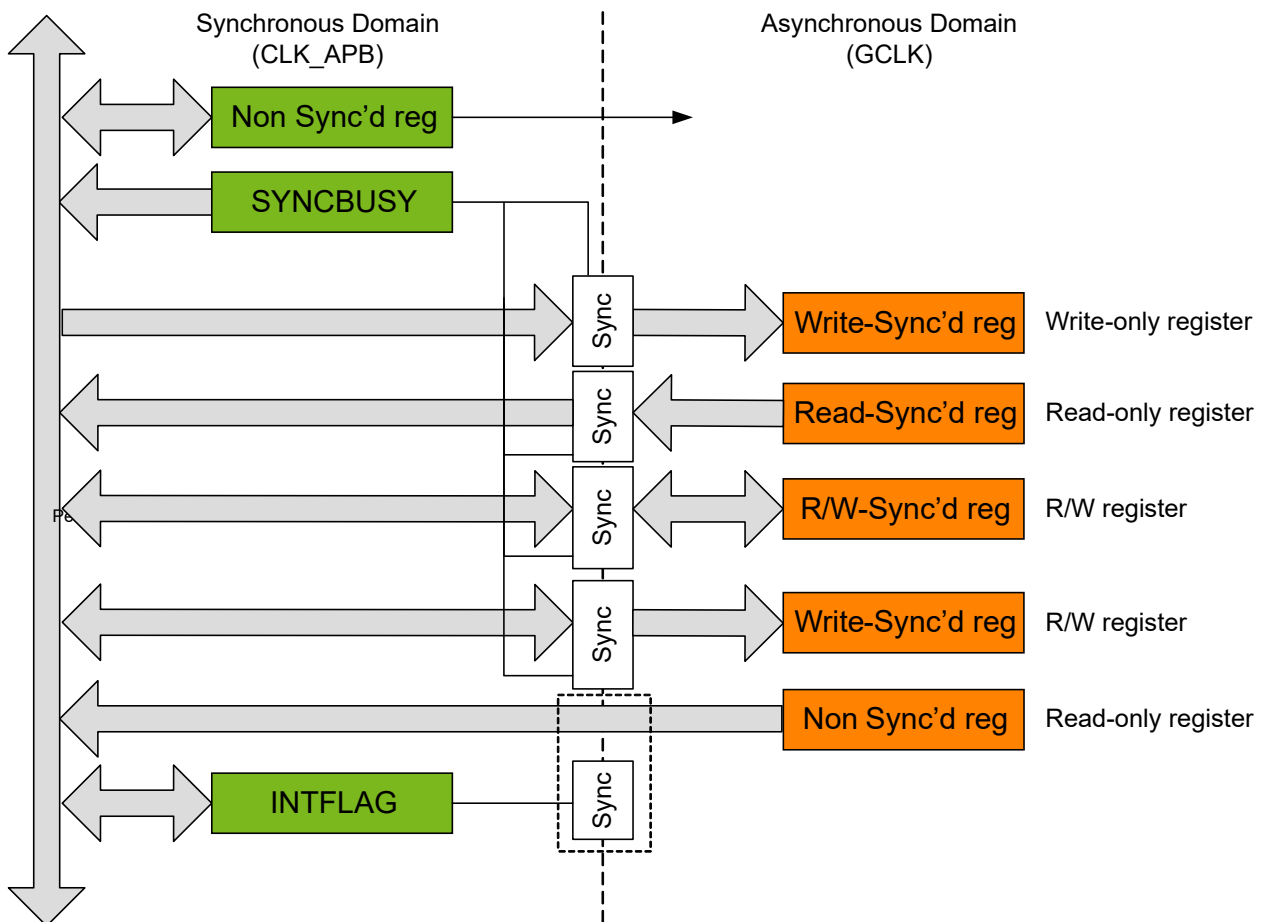
All registers in the peripheral core are synchronized when written. Some registers in the peripheral core are synchronized when read.

Each individual register description will have the properties "Read-Synchronized" and/or "Write-Synchronized" if a register is synchronized.

As shown in the figure below, each register that requires synchronization has its individual synchronizer and its individual synchronization status bit in the Synchronization Busy register (SYNCBUSY).

**Note:** For registers requiring both read- and write-synchronization, the corresponding bit in SYNCBUSY is shared.

**Figure 14-3.** Register Synchronization Overview



### 14.3.2 General Write Synchronization

Write-Synchronization is triggered by writing to a register in the peripheral clock domain (GCLK). The respective bit in the Synchronization Busy register (SYNCBUSY) will be set when the write-synchronization starts and cleared when the write-synchronization is complete. Refer also to [14.3.7. Synchronization Delay](#).

When write-synchronization is ongoing for a register, any subsequent write attempts to this register will be discarded, and an error will be reported through the Peripheral Access Controller (PAC).

#### Example:

REGA, REGB are 8-bit core registers. REGC is a 16-bit core register.

Offset	Register
0x00	REGA
0x01	REGB
0x02	REGC
0x03	

Synchronization is per register, so multiple registers can be synchronized in parallel. Consequently, after REGA (8-bit access) was written, REGB (8-bit access) can be written immediately without error.

REGC (16-bit access) can be written without affecting REGA or REGB. If REGC is written to in two consecutive 8-bit accesses without waiting for synchronization, the second write attempt will be discarded and an error is generated through the PAC.

A 32-bit access to offset 0x00 will write all three registers. Note that REGA, REGB and REGC can be updated at different times because of independent write synchronization.

### 14.3.3 General Read Synchronization

Read-synchronized registers are synchronized each time the register value is updated but the corresponding SYNCBUSY bits are not set. Reading a read-synchronized register does not start a new synchronization, it returns the last synchronized value.

**Note:** The corresponding bits in SYNCBUSY will automatically be set when the device wakes up from sleep because read-synchronized registers need to be synchronized. Therefore reading a read-synchronized register before its corresponding SYNCBUSY bit is cleared will return the last synchronized value before sleep mode.

However, if a register is also write-synchronized, any write access while the SYNCBUSY bit is set will be executed successfully. If concurrent read and write access is detected, the read is discarded and a new synchronization will start.

### 14.3.4 Completion of Synchronization

In order to check if synchronization is complete, the user can either poll the relevant bits in SYNCBUSY or use the Synchronisation Ready interrupt (if available). The Synchronization Ready interrupt flag will be set when all ongoing synchronizations are complete, i.e. when all bits in SYNCBUSY are '0'.

### 14.3.5 Write Synchronization for CTRLA.ENABLE

Setting the Enable bit in a module's Control A register (CTRLA.ENABLE) will trigger write-synchronization and set SYNCBUSY.ENABLE.

CTRLA.ENABLE will read its new value immediately after being written.

SYNCBUSY.ENABLE will be cleared by hardware when the operation is complete.

The Synchronization Ready interrupt (if available) cannot be used to enable write-synchronization.



### 14.3.6 Write-Synchronization for Software Reset Bit

Setting the Software Reset bit in CTRLA (CTRLA.SWRST=1) will trigger write-synchronization and set SYNCBUSY.SWRST. When writing a '1' to the CTRLA.SWRST bit it will immediately read as '1'.

CTRL.SWRST and SYNCBUSY.SWRST will be cleared by hardware when the peripheral has been reset.

Writing a '0' to the CTRL.SWRST bit has no effect.

The Ready interrupt (if available) cannot be used for Software Reset write-synchronization.

**Note:** Not all peripherals have the SWRST bit in the respective CTRLA register.

### 14.3.7 Synchronization Delay

The synchronization will delay write and read accesses by a certain amount. This delay  $D$  is within the range of:

$$5 \times P_{GCLK} + 2 \times P_{APB} < D < 6 \times P_{GCLK} + 3 \times P_{APB}$$

Where  $P_{GCLK}$  is the period of the generic clock and  $P_{APB}$  is the period of the peripheral bus clock. A normal peripheral bus register access duration is  $2 \times P_{APB}$ .

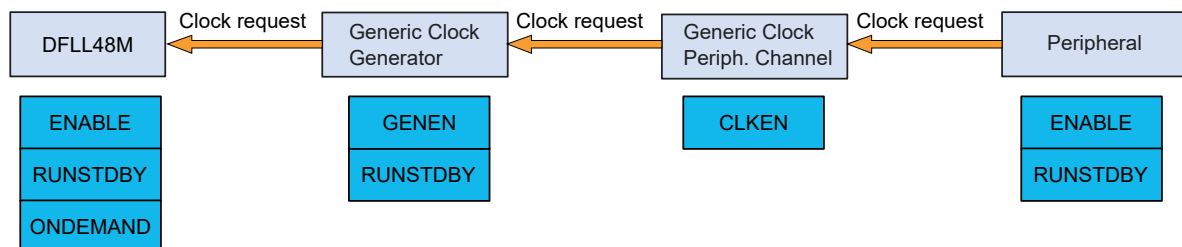
## 14.4 Enabling a Peripheral

In order to enable a peripheral that is clocked by a Generic Clock, the following parts of the system needs to be configured:

- A running Clock Source
- A clock from the Generic Clock Generator must be configured to use one of the running Clock Sources, and the Generator must be enabled.
- The Peripheral Channel that provides the Generic Clock signal to the peripheral must be configured to use a running Generic Clock Generator, and the Generic Clock must be enabled.
- The user interface of the peripheral needs to be unmasked in the PM. If this is not done the peripheral registers will read all 0's and any writing attempts to the peripheral will be discarded.

## 14.5 On Demand Clock Requests

Figure 14-4. Clock Request Routing



All clock sources in the system can be run in an on-demand mode: the clock source is in a stopped state unless a peripheral is requesting the clock source. Clock requests propagate from the peripheral, via the GCLK, to the clock source. If one or more peripheral is using a clock source, the clock source will be started/kept running. As soon as the clock source is no longer needed and no peripheral has an active request, the clock source will be stopped until requested again.

The clock request can reach the clock source only if the peripheral, the generic clock and the clock from the Generic Clock Generator in-between are enabled. The time taken from a clock request being asserted to the clock source being ready is dependent on the clock source startup time, clock source frequency as well as the divider used in the Generic Clock Generator. The total startup time  $T_{start}$  from a clock request until the clock is available for the peripheral is between:

$$T_{start\_max} = \text{Clock source startup time} + 2 \times \text{clock source periods} + 2 \times \text{divided clock source periods}$$

$T_{\text{start\_min}}$  = Clock source startup time + 1 × clock source period + 1 × divided clock source period

The time between the last active clock request stopped and the clock is shut down,  $T_{\text{stop}}$ , is between:

$T_{\text{stop\_min}}$  = 1 × divided clock source period + 1 × clock source period

$T_{\text{stop\_max}}$  = 2 × divided clock source periods + 2 × clock source periods

The On-Demand function can be disabled individually for each clock source by clearing the ONDEMAND bit located in each clock source controller. Consequently, the clock will always run whatever the clock request status is. This has the effect of removing the clock source startup time at the cost of power consumption.

The clock request mechanism can be configured to work in standby mode by setting the RUNSDTBY bits of the modules.

## 14.6 Power Consumption vs. Speed

When targeting for either a low-power or a fast acting system, some considerations have to be taken into account due to the nature of the asynchronous clocking of the peripherals:

If clocking a peripheral with a very low clock, the active power consumption of the peripheral will be lower. At the same time the synchronization to the synchronous (CPU) clock domain is dependent on the peripheral clock speed, and will take longer with a slower peripheral clock. This will cause worse response times and longer synchronization delays.

## 14.7 Clocks after Reset

On any Reset the synchronous clocks start to their initial state:

- DFLL48M is enabled and configured to run at 48MHz
- Generic Generator 0 uses DFLL48M as source and generates GCLK\_MAIN
- CPU and BUS clocks are undivided

On a Power-on Reset, the 32KHz clock sources are reset and the GCLK module starts to its initial state:

- All Generic Clock Generators are disabled except
  - Generator 0 is using DFLL48M at 48MHz as source and generates GCLK\_MAIN
- All Peripheral Channels in GCLK are disabled.

On a User Reset the GCLK module starts to its initial state, except for:

- Generic Clocks that are write-locked, i.e., the according WRTLOCK is set to 1 prior to Reset

## 15. Generic Clock Controller (GCLK)

### 15.1 Overview

Depending on the application, peripherals may require specific clock frequencies to operate correctly. The Generic Clock controller (GCLK) features 12 Generic Clock Generators [11:0] that can provide a wide range of clock frequencies.

Generators can be set to use different external and internal oscillators as source. The clock of each Generator can be divided. The outputs from the Generators are used as sources for the Peripheral Channels, which provide the Generic Clocks (GCLK\_PERIPH) to the peripheral modules, as shown in Figure 15-2. The number of peripheral clocks depends on how many peripherals the device has.

**Note:** The Generic Clock Generator 0 is always the direct source of the GCLK\_MAIN signal.

### 15.2 Features

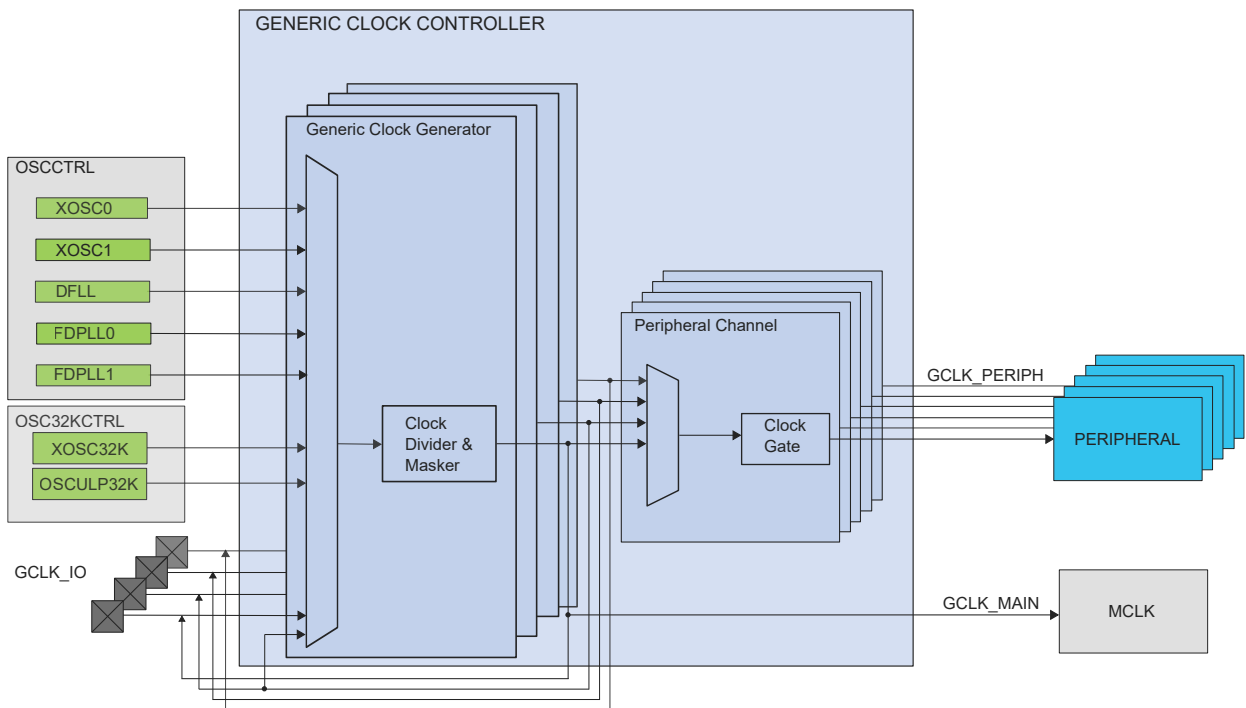
The following are key features of the GCLK module:

- Provides a device-defined, configurable number of Peripheral Channel clocks
- Wide frequency range:
  - Various clock sources
  - Embedded dividers

### 15.3 Block Diagram

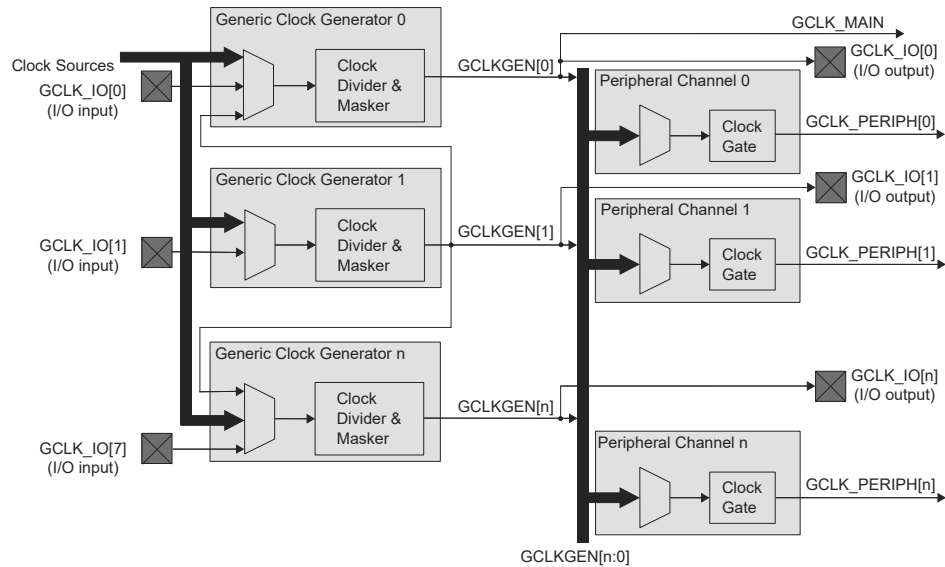
The generation of Peripheral Clock signals (GCLK\_PERIPH) and the Main Clock (GCLK\_MAIN) can be seen in the following figure.

Figure 15-1. Device Clocking Diagram



The GCLK block diagram is shown below:

Figure 15-2. Generic Clock Controller Block Diagram



## 15.4 Signal Description

Table 15-1. GCLK Signal Description

Signal Name	Type	Description
GCLK_IO[7:0]	Digital I/O	Clock source for Generators when input Generic Clock signal when output

### Notes:

- One signal can be mapped on several pins.
- Each GCLK\_IO[x] signal is connected to the related Generic Clock Generator x, for x in [7:0]. However, GCLK\_IO[8] does not exist, so the Generic Clock Generator 8 is not connected to an external pin.

## 15.5 Peripheral Dependencies

<b>Peripheral Name</b>	GCLK - Generic Clock Controller
<b>Base Address</b>	0x4000_1C00 (Peripheral Bus A)
<b>MCLK APB Clock (1)</b>	CLK_GCLK_APB, Enabled, APBAMASK.GCLK
<b>GCLK Peripheral Channel Index:Clock Name (2)</b>	n/a
<b>PAC Peripheral Peripheral Identifier (PAC.WRCTRL)</b>	7
<b>Notes:</b>	
1. Clock Name, Default State, Mask Field.	
2. See GCLK.PCHCTRLm Register, where m = Index.	

### 15.5.1 Power Management

The GCLK can operate in sleep modes, if required. Refer to the Sleep mode description in the Power Manager (PM) section.

### 15.5.2 Debug Operation

When the CPU is halted in debug mode the GCLK continues normal operation. If the GCLK is configured in a way that requires it to be periodically serviced by the CPU through interrupts or similar, improper operation or data loss may result during debugging.

### 15.5.3 Register Access Protection

All registers with write access can be optionally write-protected by the Peripheral Access Controller (PAC).

**Note:** Optional write protection is indicated by the "PAC Write Protection" property in the register description.

Write protection does not apply for accesses through an external debugger.

## 15.6 Functional Description

### 15.6.1 Principle of Operation

The GCLK module is comprised of twelve Generic Clock Generators (Generators) sourcing up to 46 Peripheral Channels and the Main Clock signal GCLK\_MAIN.

A clock source selected as input to a Generator can either be used directly or it can be prescaled in the Generator. A generator output is used by one or more Peripheral Channels to provide a peripheral generic clock signal (GCLK\_PERIPH[m]) to the peripherals.

#### 15.6.1.1 Basic Operation

##### 15.6.1.1.1 Initialization

Before a Generator is enabled, the corresponding clock source must be enabled. The Peripheral clock must be configured as outlined by the following steps:

1. The Generator must be enabled (GENCTRLn.GENEN=1) and the division factor must be set (GENTRLn.DIVSEL and GENCTRLn.DIV) by performing a single 32-bit write to the Generator Control register (GENCTRLn).
2. The Generic Clock for a peripheral must be configured by writing to the Peripheral Channel Control register (PCHCTRLm) belonging to the peripheral. The Generator used as the source for the Peripheral Clock must be written to the GEN bit field in the Peripheral Channel Control register (PCHCTRLm.GEN).

**Note:** Each Generator n is configured by one dedicated register GENCTRLn.

**Note:** Each Peripheral Channel m is configured by one dedicated register PCHCTRLm. See [PCHCTRLm Mapping](#) for the mapping of the peripheral to index m.

##### 15.6.1.1.2 Enabling, Disabling, and Resetting

The GCLK module has no enable/disable bit to enable or disable the whole module.

The GCLK is reset by setting the Software Reset bit in the Control A register (CTRLA.SWRST) to 1. All registers in the GCLK will be reset to their initial state, except for Peripheral Channels and associated Generators that have their Write Lock bit set to 1 (PCHCTRLm.WRTLOCK). For further details, refer to [15.6.1.2.4. Configuration Lock](#).

##### 15.6.1.1.3 Generic Clock Generator

Each Generator (GCLK\_GEN) can be set to run from one of eight different clock sources except GCLK\_GEN[1], which can be set to run from one of seven sources. GCLK\_GEN[1] is the only Generator that can be selected as source to others Generators.

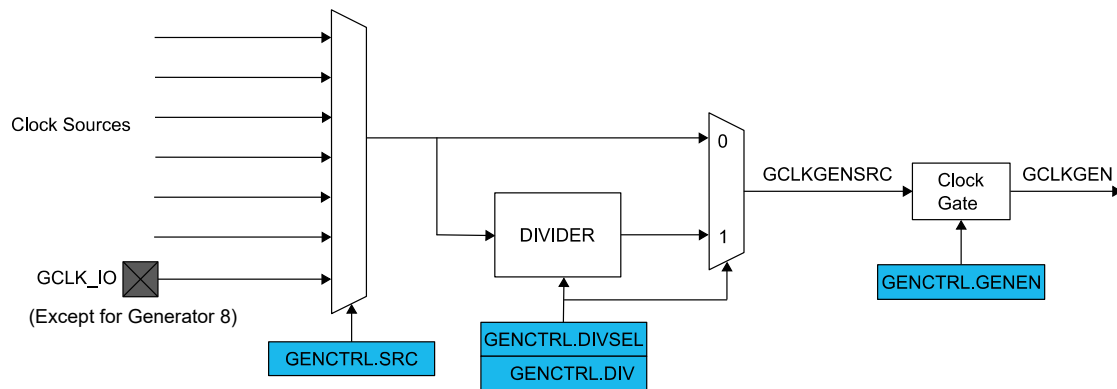
Each generator GCLK\_GEN[x] (except GCLK\_GEN[8]) can be connected to one specific pin GCLK\_IO[x]. A pin GCLK\_IO[x] can be set either to act as source to GCLK\_GEN[x] or to output the clock signal generated by GCLK\_GEN[x].

The selected source can be divided. Each Generator can be enabled or disabled independently.

Each GCLK\_GEN clock signal can then be used as clock source for one or more Peripheral Channels. Each Generator output can be allocated to one or more Peripherals.

GCLK\_GEN[0] is used as GCLK\_MAIN for the synchronous clock controller inside the Main Clock Controller. Refer to the Main Clock Controller description for details on the synchronous clock generation.

**Figure 15-3.** Generic Clock Generator



#### 15.6.1.1.4 Enabling a Generator

A Generator is enabled by writing a '1' to the Generator Enable bit in the Generator Control register (GENCTRLn.GENEN=1).

#### 15.6.1.1.5 Disabling a Generator

A Generator is disabled by writing a '0' to GENCTRLn.GENEN. When GENCTRLn.GENEN=0, the GCLK\_GEN[n] clock is disabled and gated.

#### 15.6.1.1.6 Selecting a Clock Source for the Generator

Each Generator can individually select a clock source by setting the Source Select bit group in the Generator Control register (GENCTRLn.SRC).

Changing from one clock source, for example A, to another clock source, B, can be done on the fly: If clock source B is not ready, the Generator will continue using clock source A. As soon as source B is ready, the Generator will switch to it. During the switching operation, the Generator maintains clock requests to both clock sources A and B, and will release source A as soon as the switch is done. The according bit in SYNCBUSY register (SYNCBUSY.GENCTRLn) will remain '1' until the switch operation is completed.

The available clock sources are device dependent (usually the oscillators, RC oscillators, DPLL). Only Generator 1 can be used as a common source for all other generators.

#### 15.6.1.1.7 Changing the Clock Frequency

The selected source for a Generator can be divided by writing a division value in the Division Factor bit field of the Generator Control register (GENCTRLn.DIV). How the actual division factor is calculated is depending on the Divide Selection bit (GENCTRLn.DIVSEL).

If GENCTRLn.DIVSEL=0 and GENCTRLn.DIV is either 0 or 1, the output clock will be undivided.

**Note:** The number of available DIV bits may vary from Generator to Generator.

#### 15.6.1.1.8 Duty Cycle

When dividing a clock with an odd division factor, the duty-cycle will not be 50/50. Setting the Improve Duty Cycle bit of the Generator Control register (GENCTRLn.IDC) will result in a 50/50 duty cycle.

#### 15.6.1.1.9 External Clock

The output clock (GCLK\_GEN) of each Generator can be sent to I/O pins (GCLK\_IO).

If the Output Enable bit in the Generator Control register is set ( $GENCTRLn.OE = 1$ ) and the generator is enabled ( $GENCTRLn.GENEN=1$ ), the Generator requests its clock source and the  $GCLK\_GEN$  clock is output to an I/O pin.

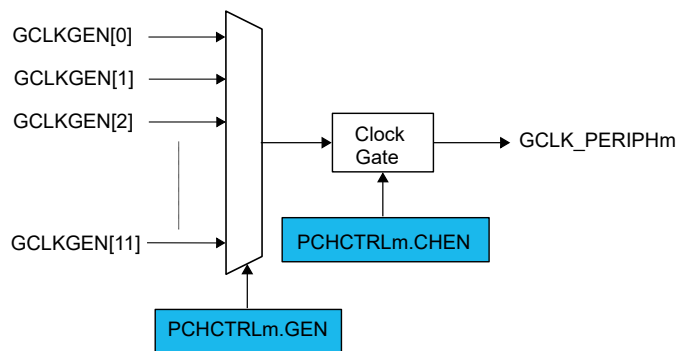
**Note:** The I/O pin ( $GCLK/IO[n]$ ) must first be configured as output by writing the corresponding PORT registers.

If  $GENCTRLn.OE$  is 0, the according I/O pin is set to an Output Off Value, which is selected by  $GENCTRLn.OOV$ : If  $GENCTRLn.OOV$  is '0', the output clock will be low. If this bit is '1', the output clock will be high.

In Standby mode, if the clock is output ( $GENCTRLn.OE=1$ ), the clock on the I/O pin is frozen to the OOV value if the Run In Standby bit of the Generic Control register ( $GENCTRLn.RUNSTDBY$ ) is zero. If  $GENCTRLn.RUNSTDBY$  is '1', the  $GCLKGEN$  clock is kept running and output to the I/O pin.

### 15.6.1.2 Peripheral Clock

Figure 15-4. Peripheral Clock



#### 15.6.1.2.1 Enabling a Peripheral Clock

Before a Peripheral Clock is enabled, one of the Generators must be enabled ( $GENCTRLn.GENEN$ ) and selected as source for the Peripheral Channel by setting the Generator Selection bits in the Peripheral Channel Control register ( $PCHCTRLm.GEN$ ). Any available Generator can be selected as clock source for each Peripheral Channel. (See [PCHCTRLm Mapping](#) for the mapping of the peripheral to index  $m$ .)

When a Generator has been selected, the peripheral clock is enabled by setting the Channel Enable bit in the Peripheral Channel Control register,  $PCHCTRLm.CHEN = 1$ . The  $PCHCTRLm.CHEN$  bit must be synchronized to the generic clock domain.  $PCHCTRLm.CHEN$  will continue to read as its previous state until the synchronization is complete.

#### 15.6.1.2.2 Disabling a Peripheral Clock

A Peripheral Clock is disabled by writing  $PCHCTRLm.CHEN=0$ . The  $PCHCTRLm.CHEN$  bit must be synchronized to the Generic Clock domain.  $PCHCTRLm.CHEN$  will stay in its previous state until the synchronization is complete. The Peripheral Clock is gated when disabled.

#### 15.6.1.2.3 Selecting the Clock Source for a Peripheral

When changing a peripheral clock source by writing to  $PCHCTRLm.GEN$ , the peripheral clock must be disabled before re-enabling it with the new clock source setting. This prevents glitches during the transition:

1. Disable the Peripheral Channel by writing  $PCHCTRLm.CHEN=0$ .
2. Verify that  $PCHCTRLm.CHEN$  reads '0'.
3. Change the source of the Peripheral Channel by writing  $PCHCTRLm.GEN$ .
4. Re-enable the Peripheral Channel by writing  $PCHCTRLm.CHEN=1$ .
5. Assert that  $PCHCTRLm.CHEN$  reads '1'.

### 15.6.1.2.4 Configuration Lock

The peripheral clock configuration can be locked for further write accesses by setting the Write Lock bit in the Peripheral Channel Control register PCHCTRLm.WRTLOCK=1). After this, all writing to the PCHCTRLm register will be ignored. It can only be unlocked by a Power Reset.

The Generator source of a locked Peripheral Channel will be locked, too: The corresponding GENCTRLn register is locked, and can be unlocked only by a Power Reset.

The Generator 0 is one exception concerning the configuration lock. As it is used as GCLK\_MAIN, it cannot be locked. It is reset by any Reset and will start up in a known configuration. The software reset (CTRLA.SWRST) can not unlock the registers.

In case of an external Reset, the Generator source will be disabled. Even if the WRTLOCK bit is written to '1' the peripheral channels are disabled (PCHCTRLm.CHEN set to '0') until the Generator source is enabled again. Then, the PCHCTRLm.CHEN are set to '1' again.

## 15.6.2 Additional Features

### 15.6.2.1 Peripheral Clock Enable after Reset

The Generic Clock Controller must be able to provide a generic clock to some specific peripherals after a Reset. That means that the configuration of the Generators and Peripheral Channels after Reset is device-dependent.

Refer to GENCTRLn.SRC for details on GENCTRLn reset.

Refer to PCHCTRLm.SRC for details on PCHCTRLm reset.

## 15.6.3 Sleep Mode Operation

### 15.6.3.1 SleepWalking

The GCLK module supports the SleepWalking feature.

If the system is in a sleep mode where the Generic Clocks are stopped, a peripheral that needs its clock in order to execute a process must first request it from the Generic Clock Controller.

The Generic Clock Controller receives this request, determines which Generic Clock Generator is involved and which clock source needs to be awakened. It then wakes up the respective clock source, enables the Generator and Peripheral Channel stages successively, and delivers the clock to the peripheral.

The RUNSTDBY bit in the Generator Control register controls clock output to pin during standby sleep mode. If the bit is cleared, the Generator output is not available on pin. When set, the GCLK can continuously output the generator output to the GCLK\_IO[n] pin. Refer to [15.6.1.1.9. External Clock](#) for details.

### 15.6.3.2 Minimize Power Consumption in Standby

The following table identifies when a Clock Generator is off in Standby Mode, minimizing the power consumption:

**Table 15-2.** Clock Generator n Activity in Standby Mode

Request for Clock n present	GENCTRLn.RUNSTDBY	GENCTRLn.OE	Clock Generator n
yes	-	-	active
no	1	1	active
no	1	0	OFF
no	0	1	OFF
no	0	0	OFF

### 15.6.3.3 Entering Standby Mode

There may occur a delay when the device is put into Standby before the power is turned off. This delay is caused by running Clock Generators: if the Run in Standby bit in the Generator Control



register (GENCTRLn.RUNSTDBY) is '0', GCLK must verify that the clock is turned off properly. The duration of this verification is frequency-dependent.

#### 15.6.4 Synchronization

Due to asynchronicity between the main clock domain and the peripheral clock domains, some registers need to be synchronized when written or read.

An exception is the Channel Enable bit in the Peripheral Channel Control registers (PCHCTRLm.CHEN). When changing this bit, the bit value must be read-back to ensure the synchronization is complete (polling method) and to assert glitch free internal operation. Note that changing the bit value under ongoing synchronization will *not* generate an error.

The following registers are synchronized when written:

- Generic Clock Generator Control register (GENCTRLn)
- Control A register (CTRLA)

Required write synchronization is denoted by the "Write-Synchronized" property in the register description.

## 15.7 Register Summary

Offset	Name	Bit Pos.	7	6	5	4	3	2	1	0
0x00	CTRLA	7:0								SWRST
0x01 ... 0x03	Reserved									
0x04	SYNCBUSY	7:0	GENCTRL5	GENCTRL4	GENCTRL3	GENCTRL2	GENCTRL1	GENCTRL0		SWRST
		15:8			GENCTRL11	GENCTRL10	GENCTRL9	GENCTRL8	GENCTRL7	GENCTRL6
		23:16								
		31:24								
0x08 ... 0x1F	Reserved									
0x20	GENCTRL0	7:0					SRC[3:0]			
		15:8			RUNSTDBY	DIVSEL	OE	OOV	IDC	GENEN
		23:16	DIV[7:0]							
		31:24	DIV[15:8]							
...										
0x4C	GENCTRL11	7:0					SRC[3:0]			
		15:8			RUNSTDBY	DIVSEL	OE	OOV	IDC	GENEN
		23:16	DIV[7:0]							
		31:24	DIV[15:8]							
0x50 ... 0x7F	Reserved									
0x80	PCHCTRL0	7:0	WRTLOCK	CHEN			GEN[3:0]			
		15:8								
		23:16								
		31:24								
...										
0x013C	PCHCTRL47	7:0	WRTLOCK	CHEN			GEN[3:0]			
		15:8								
		23:16								
		31:24								

### 15.7.1 Control A

**Name:** CTRLA  
**Offset:** 0x00  
**Reset:** 0x00  
**Property:** PAC Write-Protection, Write-Synchronized bit(s)

Bit	7	6	5	4	3	2	1	0
								SWRST
Access								R/W
Reset								0

#### Bit 0 – SWRST Software Reset

Writing a zero to this bit has no effect.

Setting this bit to 1 will reset all registers in the GCLK to their initial state after a Power Reset, except for generic clocks and associated Generators that have their WRTLOCK bit in PCHCTRLm set to 1.

Refer to GENCTRL Reset Value for details on GENCTRLn register reset.

Refer to PCHCTRL Reset Value for details on PCHCTRLm register reset.

Due to synchronization, there is a waiting period between setting CTRLA.SWRST and a completed Reset. CTRLA.SWRST and SYNCBUSY.SWRST will both be cleared when the reset is complete.

**Notes:**

1. When the CTRLA.SWRST is written, the user must poll the SYNCBUSY.SWRST bit to know when the reset operation is complete.
2. During a SWRST, access to registers or bits without SWRST are disallowed until the SYNCBUSY.SWRST bit is cleared by hardware.

Value	Description
0	There is no Reset operation ongoing.
1	A Reset operation is ongoing.

## 15.7.2 Synchronization Busy

**Name:** SYNCBUSY  
**Offset:** 0x04  
**Reset:** 0x00000000  
**Property:** -

Bit	31	30	29	28	27	26	25	24
Access								
Reset								
Bit	23	22	21	20	19	18	17	16
Access								
Reset								
Bit	15	14	13	12	11	10	9	8
Access			GENCTRL11	GENCTRL10	GENCTRL9	GENCTRL8	GENCTRL7	GENCTRL6
Reset			R	R	R	R	R	R
Reset			0	0	0	0	0	0
Bit	7	6	5	4	3	2	1	0
Access	GENCTRL5	GENCTRL4	GENCTRL3	GENCTRL2	GENCTRL1	GENCTRL0		SWRST
Reset	R	R	R	R	R	R		R
Reset	0	0	0	0	0	0		0

### Bits 2, 3, 4, 5, 6, 7, 8, 9, 10, 11, 12, 13 - GENCTRLn Generator Control n Synchronization Busy

This bit is cleared when the synchronization of the Generator Control n register (GENCTRLn) between clock domains is complete, or when clock switching operation is complete.

This bit is set when the synchronization of the Generator Control n register (GENCTRLn) between clock domains is started.

### Bit 0 - SWRST Software Reset Synchronization Busy

This bit is cleared when the synchronization of the CTRLA.SWRST register bit between clock domains is complete.

This bit is set when the synchronization of the CTRLA.SWRST register bit between clock domains is started.

### 15.7.3 Generator Control

**Name:** GENCTRLn  
**Offset:** 0x20 + n\*0x04 [n=0..11]  
**Reset:** 0x00000106  
**Property:** PAC Write-Protection, Write-Synchronized

GENCTRLn controls the settings of Generic Generator n (n=[11:0]). The reset value is 0x00000106 for Generator n=0, else 0x00000000

**Note:** GENCTRLn is a write-synchronized register: SYNCBUSY.GENCTRLn must be checked to ensure the GENCTRLn synchronization is complete.

Bit	31	30	29	28	27	26	25	24
	DIV[15:8]							
Access	R/W	R/W	R/W	R/W	R/W	R/W	R/W	R/W
Reset	0	0	0	0	0	0	0	0
Bit	23	22	21	20	19	18	17	16
	DIV[7:0]							
Access	R/W	R/W	R/W	R/W	R/W	R/W	R/W	R/W
Reset	0	0	0	0	0	0	0	0
Bit	15	14	13	12	11	10	9	8
			RUNSTDBY	DIVSEL	OE	OOV	IDC	GENEN
Access			R/W	R/W	R/W	R/W	R/W	R/W
Reset			0	0	0	0	0	1
Bit	7	6	5	4	3	2	1	0
					SRC[3:0]			
Access					R/W	R/W	R/W	R/W
Reset					0	0	0	0

#### Bits 31:16 – DIV[15:0] Division Factor

These bits represent a division value for the corresponding Generator. The actual division factor is dependent on the state of DIVSEL. The number of relevant DIV bits for each Generator can be seen in this table. Written bits outside of the specified range will be ignored.

**Table 15-3.** Division Factor Bits

Generic Clock Generator	Division Factor Bits	Maximum Division Factor
Generator 0	8 division factor bits - DIV[7:0]	512
Generator 1	16 division factor bits - DIV[15:0]	131072
Generator 2 - 11	8 division factor bits - DIV[7:0]	512

#### Bit 13 – RUNSTDBY Run in Standby

This bit is used to keep the Generator running in Standby as long as it is configured to output to a dedicated GCLK\_IOn pin. If GENCTRLn.OE is zero, this bit has no effect and the generator will only be running if a peripheral requires the clock.

Value	Description
0	The Generator is stopped in Standby and the GCLK_IOn pin state (one or zero) will be dependent on the setting in GENCTRL.OOV.
1	The Generator is kept running and output to its dedicated GCLK_IOn pin during Standby mode.

### Bit 12 – DIVSEL Divide Selection

This bit determines how the division factor of the clock source of the Generator will be calculated from DIV. If the clock source should not be divided, DIVSEL must be 0 and the GENCTRLn.DIV value must be either 0 or 1.

Value	Description
0	The Generator clock frequency equals the clock source frequency divided by GENCTRLn.DIV.
1	The Generator clock frequency equals the clock source frequency divided by $2^{(N+1)}$ , where N is the Division Factor Bits for the selected generator (refer to GENCTRLn.DIV).

### Bit 11 – OE Output Enable

This bit is used to output the Generator clock output to the corresponding pin (GCLK\_IO[7..0]), as long as GCLK\_IOn is not defined as the Generator source in the GENCTRLn.SRC bit field.

Value	Description
0	No Generator clock signal on pin GCLK_IOn.
1	The Generator clock signal is output on the corresponding GCLK_IOn, unless GCLK_IOn is selected as a generator source in the GENCTRLn.SRC bit field.

### Bit 10 – OOV Output Off Value

This bit is used to control the clock output value on pin (GCLK\_IO[7..0]) when the Generator is turned off or the OE bit is zero, as long as GCLK\_IOn is not defined as the Generator source in the GENCTRLn.SRC bit field.

Value	Description
0	The GCLK_IOn will be LOW when generator is turned off or when the OE bit is zero.
1	The GCLK_IOn will be HIGH when generator is turned off or when the OE bit is zero.

### Bit 9 – IDC Improve Duty Cycle

This bit is used to improve the duty cycle of the Generator output to 50/50 for odd division factors.

Value	Description
0	Generator output clock duty cycle is not balanced to 50/50 for odd division factors.
1	Generator output clock duty cycle is 50/50.

### Bit 8 – GENEN Generator Enable

This bit is used to enable and disable the Generator.

Value	Description
0	Generator is disabled.
1	Generator is enabled.

### Bits 3:0 – SRC[3:0] Generator Clock Source Selection

These bits select the Generator clock source, as shown in this table.

**Table 15-4.** Generator Clock Source Selection

Value	Name	Description
0x00	XOSC0	XOSC 0 oscillator output
0x01	XOSC1	XOSC 1 oscillator output
0x02	GCLK_IN	Generator input pad (GCLK_IO)
0x03	GCLK_GEN1	Generic clock generator 1 output
0x04	OSCULP32K	OSCULP32K oscillator output
0x05	XOSC32K	XOSC32K oscillator output
0x06	DFLL	DFLL48M oscillator output
0x07	DPLL0	FDPLL200M0 output
0x08	DPLL1	FDPLL200M1 output
0x09-0x1F	Reserved	Reserved

A Power Reset will reset all GENCTRLn registers. the Reset values of the GENCTRLn registers are shown in table below.

**Table 15-5.** GENCTRLn Reset Value after a Power Reset

GCLK Generator	Reset Value after a Power Reset
0	0x00000106
others	0x00000000

A User Reset will reset the associated GENCTRL register unless the Generator is the source of a locked Peripheral Channel (PCHCTRLm.WRTLOCK=1). The reset values of the GENCTRL register are as shown in the table below.

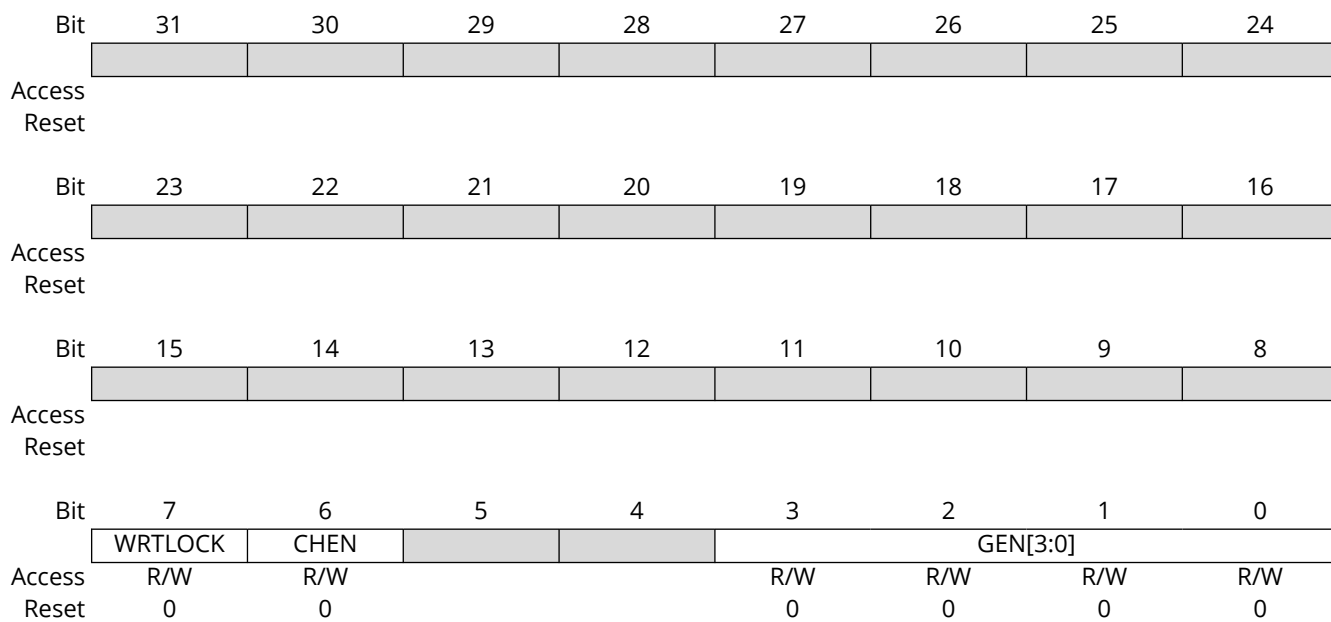
**Table 15-6.** GENCTRLn Reset Value after a User Reset

GCLK Generator	Reset Value after a User Reset
0	0x00000106
others	No change if the generator is used by a Peripheral Channel m with PCHCTRLm.WRTLOCK=1 else 0x00000000

## 15.7.4 Peripheral Channel Control

**Name:** PCHCTRLm  
**Offset:** 0x80 + m\*0x04 [m=0..47]  
**Reset:** 0x00000000  
**Property:** PAC Write-Protection

PCHCTRLm controls the settings of Peripheral Channel number m (m=[47:0]).



### Bit 7 - WRTLOCK Write Lock

After this bit is set to '1', further writes to the PCHCTRLm register will be discarded. The control register of the corresponding Generator n (GENCTRLn), as assigned in PCHCTRLm.GEN, will also be locked. It can only be unlocked by a Power Reset.

Note that Generator 0 cannot be locked.

Value	Description
0	The Peripheral Channel register and the associated Generator register are not locked
1	The Peripheral Channel register and the associated Generator register are locked

### Bit 6 - CHEN Channel Enable

This bit is used to enable and disable a Peripheral Channel.

Value	Description
0	The Peripheral Channel is disabled
1	The Peripheral Channel is enabled

### Bits 3:0 - GEN[3:0] Generator Selection

This bit field selects the Generator to be used as the source of a peripheral clock, as shown in the table below:

**Table 15-7. Generator Selection**

Value	Description
0x0	Generic Clock Generator 0
0x1	Generic Clock Generator 1
0x2	Generic Clock Generator 2
0x3	Generic Clock Generator 3
0x4	Generic Clock Generator 4



**Table 15-8.** Reset Value after a User Reset or a Power Reset

Reset	PCHCTRLm.GEN	PCHCTRLm.CHEN	PCHCTRLm.WRTLOCK
Power Reset	0x0	0x0	0x0
User Reset	If WRTLOCK= 0 : 0x0 If WRTLOCK = 1: no change	If WRTLOCK= 0 : 0x0 If WRTLOCK = 1: no change	No change

A Power Reset will reset all the PCHCTRLm registers.

A User Reset will reset a PCHCTRL if WRTLOCK=0, or else, the content of that PCHCTRL remains unchanged.

PCHCTRL register Reset values are shown in the table PCHCTRLm Mapping.

**Table 15-9.** PCHCTRLm Mapping

index(m)	Name	Description
0	GCLK_OSCCTRL_DFLL48	DFLL48 input clock source
1	GCLK_OSCCTRL_FDPLL0	Reference clock for FDPLL0
2	GCLK_OSCCTRL_FDPLL1	Reference clock for FDPLL1
3	GCLK_OSCCTRL_FDPLL0_32K GCLK_OSCCTRL_FDPLL1_32K GCLK_SDHC0_SLOW GCLK_SDHC1_SLOW GCLK_SERCOM[0..7]_SLOW	FDPLL0 32KHz clock for internal lock timer FDPLL1 32KHz clock for internal lock timer SDHC0 Slow SDHC1 Slow SERCOM[0..7] Slow
4	GCLK_EIC	EIC
5	GCLK_FREQM_MSR	FREQM Measure
6	GCLK_FREQM_REF	FREQM Reference
7	GCLK_SERCOM0_CORE	SERCOM0 Core
8	GCLK_SERCOM1_CORE	SERCOM1 Core
9	GCLK_TC0, GCLK_TC1	TC0, TC1
10	GCLK_USB	USB
22:11	GCLK_EVSYS[0..11]	EVSYS[0..11]
23	GCLK_SERCOM2_CORE	SERCOM2 Core
24	GCLK_SERCOM3_CORE	SERCOM3 Core
25	GCLK_TCC0, GCLK_TCC1	TCC0, TCC1
26	GCLK_TC2, GCLK_TC3	TC2, TC3
27	GCLK_CAN0	CAN0
28	GCLK_CAN1	CAN1
29	GCLK_TCC2, GCLK_TCC3	TCC2, TCC3
30	GCLK_TC4, GCLK_TC5	TC4, TC5
31	GCLK_PDEC	PDEC
32	GCLK_AC	AC
33	GCLK_CCL	CCL
34	GCLK_SERCOM4_CORE	SERCOM4 Core
35	GCLK_SERCOM5_CORE	SERCOM5 Core
36	GCLK_SERCOM6_CORE	SERCOM6 Core
37	GCLK_SERCOM7_CORE	SERCOM7 Core
38	GCLK_TCC4	TCC4
39	GCLK_TC6, GCLK_TC7	TC6, TC7
40	GCLK_ADC0	ADC0
41	GCLK_ADC1	ADC1
42	GCLK_DAC	DAC
44:43	GCLK_I2S	I2S
45	GCLK_SDHC0	SDHC0
46	GCLK_SDHC1	SDHC1
47	GCLK_CM4_TRACE	CM4 Trace

## 16. Main Clock (MCLK)

### 16.1 Overview

The Main Clock (MCLK) controls the synchronous clock generation of the device.

Using a clock provided by the Generic Clock Module (GCLK\_MAIN), the Main Clock Controller provides synchronous system clocks to the CPU and the modules connected to the AHBx and the APBx buses. The synchronous system clocks are divided into a number of clock domains. Each clock domain can run at different frequencies, enabling the user to save power by running peripherals at a relatively low clock frequency, while maintaining high CPU performance or vice versa. In addition, the clock can be masked for individual modules, enabling the user to minimize power consumption by disabling individual modules.

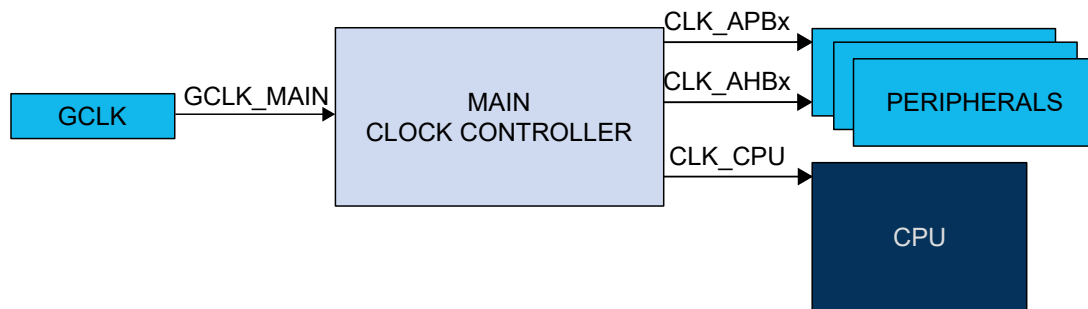
### 16.2 Features

The following are key features of the MCLK:

- Generates CPU, AHB, and APB system clocks
  - Clock source and division factor from GCLK
  - Clock prescaler with 1x to 128x division
- Safe run-time clock switching from GCLK
- Module-level clock gating through maskable peripheral clocks

### 16.3 Block Diagram

Figure 16-1. MCLK Block Diagram



**Note:** x = A, B, C or D.

### 16.4 Peripheral Dependencies

Peripheral Name	MCLK – Main Clock
Base Address	0x4000_0800 (Peripheral Bus A)
NVIC IRQ Index:Source	1 : CKRDY
MCLK APB Clock (1)	CLK_MCLK_APB, Enabled, APBAMASK.MCLK
GCLK Peripheral Channel Index:Clock Name	n/a
PAC Peripheral Identifier (PAC.WRCTRL)	2

**Note:**

1. Clock Name, Default State, Mask Field.

**16.4.1 Power Management**

The MCLK will operate in all sleep modes if a synchronous clock is required in these modes.

**16.4.2 Clocks**

The MCLK bus clock (CLK\_MCLK\_APB) can be enabled and disabled in the Main Clock module, and the default state of CLK\_MCLK\_APB can be found in the Peripheral Clock Masking section. If this clock is disabled, it can only be re-enabled by a reset.

The Generic Clock GCLK\_MAIN is required to generate the Main Clocks. GCLK\_MAIN is configured in the Generic Clock Controller, and can be re-configured by the user if needed.

**16.4.2.1 Main Clock**

The main clock CLK\_MAIN is the common source for the synchronous clocks. This is fed into the common 8-bit prescaler that is used to generate synchronous clocks to the CPU, AHBx, and APBx modules.

**16.4.2.2 CPU Clock**

The CPU clock (CLK\_CPU) is routed to the CPU. Halting the CPU clock inhibits the CPU from executing instructions.

**16.4.2.3 APBx and AHBx Clock**

The APBx clocks (CLK\_APBx) and the AHBx clocks (CLK\_AHBx) are the root clock sources used by modules requiring a clock on the APBx and the AHBx buses. These clocks are always synchronous to the CPU clock, and can run even when the CPU clock is turned off in sleep mode. A clock gater is inserted after the common APB clock to gate any APBx clock of a module on APBx bus, as well as the AHBx clock serving that module.

**16.4.2.4 Clock Domains**

The device has these synchronous clock domains:

- High-Speed synchronous clock domain (HS Clock Domain). Frequency is  $f_{HS}$ .
- CPU synchronous clock domain (CPU Clock Domain). Frequency is  $f_{CPU}$ .

**16.4.3 Interrupts**

The interrupt request line is connected to the Interrupt Controller. Using the MCLK interrupt requires the Interrupt Controller to be configured first.

**16.4.4 Debug Operation**

When the CPU is halted in debug mode, the MCLK continues normal operation. In sleep mode, the clocks generated from the MCLK are kept running to allow the debugger accessing any module. As a consequence, power measurements are incorrect in debug mode.

**16.4.5 Register Access Protection**

All registers with write access can be write-protected optionally by the Peripheral Access Controller (PAC), except for the following registers:

- Interrupt Flag register (INTFLAG)

Optional write protection by the Peripheral Access Controller (PAC) is denoted by the "PAC Write Protection" property in each individual register description.

PAC write protection does not apply to accesses through an external debugger.

## 16.5 Functional Description

### 16.5.1 Principle of Operation

The CLK\_MAIN clock signal from the GCLK module is the source for the main clock, which in turn is the common root for the synchronous clocks for the CPU, APBx, and AHBx modules. The CLK\_MAIN is divided by an 8-bit prescaler. Each of the derived clocks can run from any divided or undivided main clock, ensuring synchronous clock sources for each clock domain. The clock domain (CPU) can be changed on the fly to respond to variable load in the application. The clocks for each module in a clock domain can be masked individually to avoid power consumption in inactive modules. Depending on the sleep mode, some clock domains can be turned off.

### 16.5.2 Basic Operation

#### 16.5.2.1 Initialization

After a Reset, the default clock source of the CLK\_MAIN clock (GCLK\_MAIN) is started and calibrated before the CPU starts running. The GCLK\_MAIN clock is selected as the main clock without any prescaler division.

By default, only the necessary clocks are enabled.

#### 16.5.2.2 Enabling, Disabling, and Resetting

The MCLK module is always enabled and cannot be reset.

#### 16.5.2.3 Selecting the Main Clock Source

Refer to the [Generic Clock Controller](#) description for details on how to configure the clock source of the GCLK\_MAIN clock.

#### 16.5.2.4 Selecting the Synchronous Clock Division Ratio

The main clock GCLK\_MAIN feeds an 8-bit prescaler, which can be used to generate the synchronous clocks. By default, the synchronous clocks run on the undivided main clock. The user can select a prescaler division for the CPU clock domain by writing the Division (DIV) bits in the CPU Clock Division register CPUDIV, resulting in a CPU clock domain frequency determined by this equation:

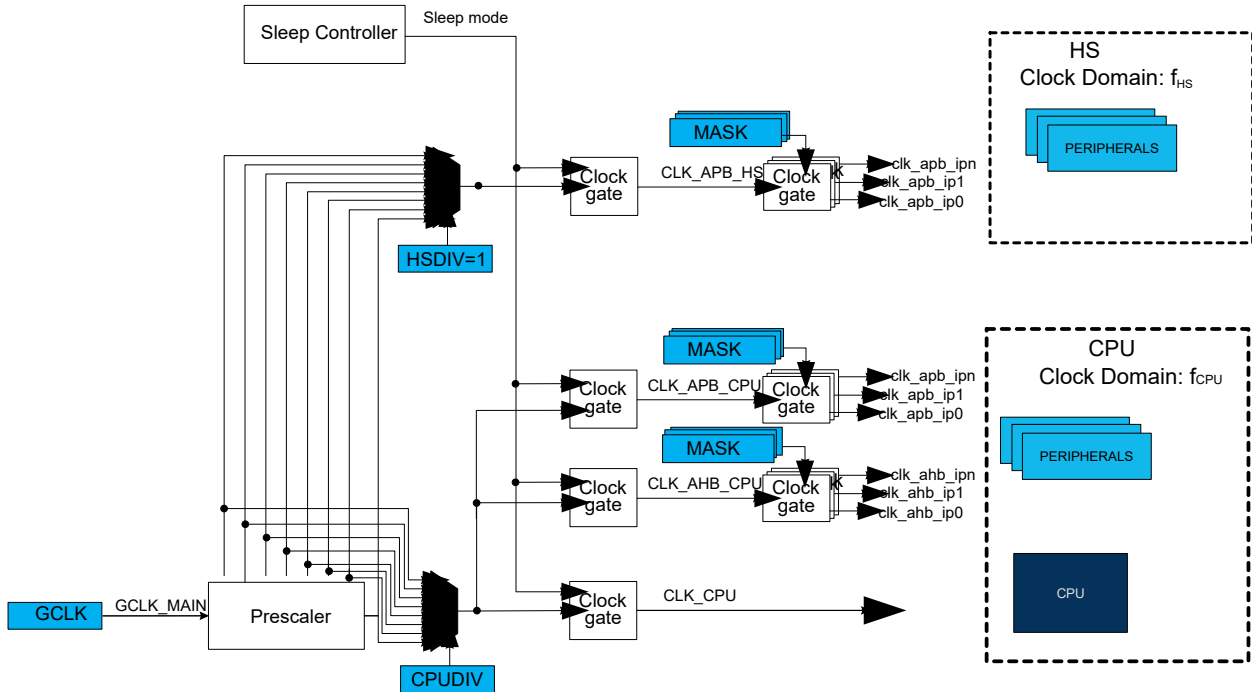
$$f_{CPU} = \frac{f_{main}}{CPUDIV}$$

Frequencies must never exceed the specified maximum frequency for each clock domain given in the electrical characteristics specifications.

If the application attempts to write forbidden values in CPUDIV register, register is written but these bad values are not used and a violation is reported to the PAC module.

Division bits (DIV) can be written without halting or disabling peripheral modules. Writing DIV bits allows a new clock setting to be written to all synchronous clocks belonging to the corresponding clock domain at the same time.

Figure 16-2. Synchronous Clock Selection and Prescaler



**Note:** A FAST clock for QSPI (CLK\_QSPI2X\_AHB) is derived from high-speed synchronous  $f_{HS}$ .

### 16.5.2.5 Clock Ready Flag

There is a slight delay between writing to CPUDIV until the new clock settings become effective.

During this interval, the Clock Ready flag in the Interrupt Flag Status and Clear register (**INTFLAG.CKRDY**) will return zero when read. If **CKRDY** in the **INTENSET** register is set to '1', the Clock Ready interrupt will be triggered when the new clock setting is effective. The new CPUDIV value must not be re-written while **INTFLAG.CKRDY** reads '0'. The system may become unstable or hang, and a violation is reported to the PAC module.

### 16.5.2.6 Peripheral Clock Masking

The user can disable or enable the AHB or APB clock for a peripheral by writing the corresponding bit in the Clock Mask registers (APBxMASK) to '0' or '1'. The default state of the peripheral clocks is shown in the following table.

Table 16-1. Peripheral Clock Default State

CPU Clock Domain	
Peripheral Clock	Default State
CLK_AC_APB	Disabled
CLK_ADC0_APB	Disabled
CLK_ADC1_APB	Disabled
CLK_AES_APB	Disabled
CLK_BRIDGE_A_AHB	Enabled
CLK_BRIDGE_B_AHB	Enabled
CLK_BRIDGE_C_AHB	Enabled
CLK_BRIDGE_D_AHB	Enabled
CLK_CAN0_AHB	Enabled
CLK_CAN1_AHB	Enabled

.....continued

CPU Clock Domain	
Peripheral Clock	Default State
CLK_CMCC_AHB	Enabled
CLK_DMACE_AHB	Enabled
CLK_DSU_AHB	Enabled
CLK_EIC_APB	Enabled
CLK_EVSYN_APB	Disabled
CLK_FREQM_APB	Disabled
CLK_GCLK_APB	Enabled
CLK_GMAC_AHB	Enabled
CLK_GMAC_APB	Disabled
CLK_ICM_AHB	Enabled
CLK_I2S_AHB	Disabled
CLK_MCLK_APB	Enabled
CLK_NVMCTRL_AHB	Enabled
CLK_NVMCTRL_APB	Enabled
CLK_NVMCTRL_CACHE	Enabled
CLK_NVMCTRL_SMEEPROM	Enabled
CLK_OSCCTRL_APB	Enabled
CLK_PAC_AHB	Enabled
CLK_PAC_APB	Enabled
CLK_PDEC_APB	Disabled
CLK_PORT_APB	Enabled
CLK_PUKCC_AHB	Enabled
CLK_QSPI_AHB	Enabled
CLK_QSPI2X_AHB	Enabled
CLK_SDHC0_AHB	Enabled
CLK_SDHC1_AHB	Enabled
CLK_SERCOM0_APB	Disabled
CLK_SERCOM1_APB	Disabled
CLK_SERCOM2_APB	Disabled
CLK_SERCOM3_APB	Disabled
CLK_SERCOM4_APB	Disabled
CLK_SERCOM5_APB	Disabled
CLK_SERCOM6_APB	Disabled
CLK_SERCOM7_APB	Disabled
CLK_TC0_APB	Disabled
CLK_TC1_APB	Disabled
CLK_TC2_APB	Disabled
CLK_TC3_APB	Disabled
CLK_TC4_APB	Disabled
CLK_TC5_APB	Disabled
CLK_TC6_APB	Disabled
CLK_TC7_APB	Disabled
CLK_TCC0_APB	Disabled
CLK_TCC1_APB	Disabled

.....continued

CPU Clock Domain	
Peripheral Clock	Default State
CLK_TCC2_APB	Disabled
CLK_TCC3_APB	Disabled
CLK_TCC4_APB	Disabled
CLK_USB_AHB	Enabled
CLK_USB_APB	Disabled
CLK_WDT_APB	Enabled
CLK_DAC_APB	Disabled
CLK_DSU_APB	Enabled
CLK_CCL_APB	Disabled
CLK_QSPI_APB	Enabled
CLK_ICM_APB	Disabled
CLK_TRNG_APB	Disabled

Backup Clock Domain	
Peripheral Clock	Default State
CLK_OSC32KCTRL_APB	Enabled
CLK_PM_APB	Enabled
CLK_SUPC_APB	Enabled
CLK_RSTC_APB	Enabled
CLK_RTC_APB	Enabled

**Note:** 1. SERCOM2 Peripheral Clock is disabled for all 24-pin packages as SERCOM2 is not present.

When the APB clock is not provided to a module, its registers cannot be read or written. The module can be re-enabled later by writing the corresponding mask bit to '1'.

A module may be connected to several clock domains (for example, AHB and APB), in which case it will have several mask bits.

The clocks must be switched off if it is certain that the module will not be used: Switching off the clock for the NVM Controller (NVMCTRL) will cause a problem if the CPU needs to read from the Flash memory. Switching off the clock to the MCLK module (which contains the mask registers) or the corresponding APBx bridge will make it impossible to write the mask registers again. In this case, they can only be re-enabled by a system reset.

### 16.5.3 Interrupts

The peripheral has the following interrupt sources:

- Clock Ready (CKRDY): indicates that CPU clocks are ready. This interrupt is a synchronous wake-up source.

Each interrupt source has an interrupt flag associated with it. The interrupt flag in the Interrupt Flag Status and Clear (INTFLAG) register is set when the interrupt condition occurs. Each interrupt can be enabled individually by writing a '1' to the corresponding enabling bit in the Interrupt Enable Set (INTENSET) register, and disabled by writing a '1' to the corresponding clearing bit in the Interrupt Enable Clear (INTENCLR) register. The status of enabled interrupts can be read from either INTENSET or INTENCLR.

An interrupt request is generated when the interrupt flag is set and the corresponding interrupt is enabled. The interrupt request remains active until the interrupt flag is cleared, the interrupt is disabled or the peripheral is reset. An interrupt flag is cleared by writing a '1' to the corresponding bit in the INTFLAG register. Each peripheral can have one interrupt request line per interrupt

source or one common interrupt request line for all the interrupt sources. If the peripheral has one common interrupt request line for all the interrupt sources, the user must read the [INTFLAG](#) register to determine which interrupt condition is present.

#### 16.5.4 Sleep Mode Operation

In Idle mode, the MCLK is still running on the selected main clock.

In Standby mode, the MCLK is frozen if no synchronous clock is required.



## 16.6 Register Summary

Offset	Name	Bit Pos.	7	6	5	4	3	2	1	0
0x00	Reserved									
0x01	INTENCLR	7:0								CKRDY
0x02	INTENSET	7:0								CKRDY
0x03	INTFLAG	7:0								CKRDY
0x04	HSDIV	7:0	DIV[7:0]							
0x05	CPUDIV	7:0	DIV[7:0]							
0x06	Reserved									
...	Reserved									
0x0F	Reserved									
0x10	AHBMASK	7:0	Reserved	NVMCTRL	Reserved	DSU	HPB3	HPB2	HPB1	HPB0
		15:8	SDHC0	GMAC	QSPI	PAC	Reserved	USB	DMAC	CMCC
		23:16	NVMCTRL_CHE	NVMCTRL_SMEEPROM	QSPI_2X	PUKCC	ICM	CAN1	CAN0	SDHC1
		31:24								
0x14	APBAMASK	7:0	GCLK	SUPC	OSC32KCTRL	OSCCTRL	RSTC	MCLK	PM	PAC
		15:8	TC1	TC0	SERCOM1	SERCOM0	FREQM	EIC	RTC	WDT
		23:16								
		31:24								
0x18	APBBMASK	7:0	EVSYS			PORT		NVMCTRL	DSU	USB
		15:8		TC3	TC2	TCC1	TCC0	SERCOM3	SERCOM2	
		23:16								RAMECC
		31:24								
0x1C	APBCMASK	7:0	PDEC	TC5	TC4	TCC3	TCC2	GMAC		
		15:8		CCL	QSPI		ICM	TRNG	AES	AC
		23:16								
		31:24								
0x20	APBDMASK	7:0	ADC0	TC7	TC6	TCC4	SERCOM7	SERCOM6	SERCOM5	SERCOM4
		15:8					PCC	I2S	DAC	ADC1
		23:16								
		31:24								

### 16.6.1 Interrupt Enable Clear

**Name:** INTENCLR  
**Offset:** 0x01  
**Reset:** 0x00  
**Property:** PAC Write-Protection

This register allows the user to disable an interrupt without doing a read-modify-write operation. Changes in this register will also be reflected in the Interrupt Enable Set (INTENSET) register.

Bit	7	6	5	4	3	2	1	0
								CKRDY
Access								R/W
Reset								0

#### Bit 0 – CKRDY Clock Ready Interrupt Enable

Writing a '0' to this bit has no effect.

Writing a '1' to this bit will clear the Clock Ready Interrupt Enable bit and the corresponding interrupt request.

Value	Description
0	The Clock Ready interrupt is disabled.
1	The Clock Ready interrupt is enabled.

## 16.6.2 Interrupt Enable Set

**Name:** INTENSET  
**Offset:** 0x02  
**Reset:** 0x00  
**Property:** PAC Write-Protection

This register allows the user to enable an interrupt without doing a read-modify-write operation. Changes in this register will also be reflected in the Interrupt Enable Clear (INTENCLR) register.

Bit	7	6	5	4	3	2	1	0
								CKRDY
Access								R/W
Reset								0

### Bit 0 – CKRDY Clock Ready Interrupt Enable

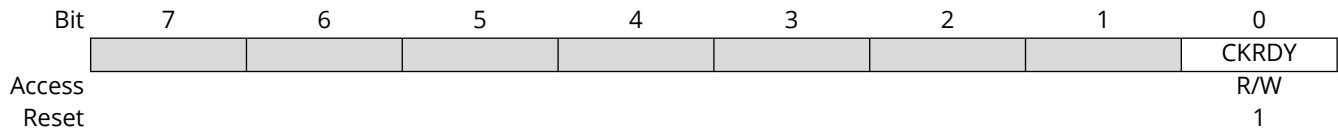
Writing a '0' to this bit has no effect.

Writing a '1' to this bit will set the Clock Ready Interrupt Enable bit and enable the Clock Ready interrupt.

Value	Description
0	The Clock Ready interrupt is disabled.
1	The Clock Ready interrupt is enabled.

### 16.6.3 Interrupt Flag Status and Clear

**Name:** INTFLAG  
**Offset:** 0x03  
**Reset:** 0x01  
**Property:** -



#### Bit 0 – CKRDY Clock Ready

This flag is cleared by writing a '1' to the flag.

This flag is set when the synchronous CPU, APBx, and AHBx clocks have frequencies as indicated in the CLKCFG registers and will generate an interrupt if [INTENCLR/SET.CKRDY](#) is '1'.

Writing a '0' to this bit has no effect.

Writing a '1' to this bit clears the Clock Ready interrupt flag.

## 16.6.4 High-Speed Clock Division

**Name:** HSDIV  
**Offset:** 0x04  
**Reset:** 0x01

Bit	7	6	5	4	3	2	1	0
	DIV[7:0]							
Access	R	R	R	R	R	R	R	R
Reset	0	0	0	0	0	0	0	1

### Bits 7:0 – DIV[7:0] HS Clock Division Factor

These bits define the division ratio of the main clock prescaler related to the HS clock domain (HSDIV).

Value	Name	Description
0x01	DIV1	Divide by 1
others	-	Reserved

### 16.6.5 CPU Clock Division

**Name:** CPUDIV  
**Offset:** 0x05  
**Reset:** 0x01  
**Property:** PAC Write-Protection

Bit	7	6	5	4	3	2	1	0
	DIV[7:0]							
Access	R/W	R/W	R/W	R/W	R/W	R/W	R/W	R/W
Reset	0	0	0	0	0	0	0	1

#### Bits 7:0 – DIV[7:0] CPU Clock Division Factor

These bits define the division ratio of the main clock prescaler related to the CPU clock domain (CPUDIV).

To ensure correct operation, frequencies must be selected so that  $f_{HS} \geq f_{CPU}$  (i.e.  $CPUDIV \geq HSDIV$ ). Frequencies must never exceed the specified maximum frequency for each clock domain.

Value	Name	Description
0x01	DIV1	Divide by 1
0x02	DIV2	Divide by 2
0x04	DIV4	Divide by 4
0x08	DIV8	Divide by 8
0x10	DIV16	Divide by 16
0x20	DIV32	Divide by 32
0x40	DIV64	Divide by 64
0x80	DIV128	Divide by 128
others	-	Reserved

## 16.6.6 AHB Mask

**Name:** AHBMASK  
**Offset:** 0x10  
**Reset:** 0x00FFFFFF  
**Property:** PAC Write-Protection

**Note:** All "Reserved" bits should be set to 1.

Bit	31	30	29	28	27	26	25	24
Access								
Reset								
Bit	23	22	21	20	19	18	17	16
Access	NVMCTRL_CACHE	NVMCTRL_SMEEPROM	QSPI_2X	PUKCC	ICM	CAN1	CAN0	SDHC1
Reset	1	1	1	1	1	1	1	1
Bit	15	14	13	12	11	10	9	8
Access	SDHC0	GMAC	QSPI	PAC	Reserved	USB	DMAC	CMCC
Reset	1	1	1	1	1	1	1	1
Bit	7	6	5	4	3	2	1	0
Access	Reserved	NVMCTRL	Reserved	DSU	HPB3	HPB2	HPB1	HPB0
Reset	1	1	1	1	1	1	1	1

### Bit 23 – NVMCTRL\_CACHE NVMCTRL\_CACHE AHB Clock Enable

Value	Description
0	The AHB clock for the NVMCTRL_CACHE is stopped.
1	The AHB clock for the NVMCTRL_CACHE is enabled.

### Bit 22 – NVMCTRL\_SMEEPROM NVMCTRL\_SMEEPROM AHB Clock Enable

Value	Description
0	The AHB clock for the NVMCTRL_SMEEPROM is stopped.
1	The AHB clock for the NVMCTRL_SMEEPROM is enabled.

### Bit 21 – QSPI\_2X QSPI\_2X AHB Clock Enable

Value	Description
0	The AHB clock for the QSPI_2X is stopped.
1	The AHB clock for the QSPI_2X is enabled.

### Bit 20 – PUKCC PUKCC AHB Clock Enable

Value	Description
0	The AHB clock for the PUKCC is stopped.
1	The AHB clock for the PUKCC is enabled.

### Bit 19 – ICM ICM AHB Clock Enable

Value	Description
0	The AHB clock for the ICM is stopped.
1	The AHB clock for the ICM is enabled.

**Bits 17, 18 – CANn** CANn AHB Clock Enable

Value	Description
0	The AHB clock for the CANn is stopped.
1	The AHB clock for the CANn is enabled.

**Bits 15, 16 – SDHCn** SDHCn AHB Clock Enable

Value	Description
0	The AHB clock for the SDHCn is stopped.
1	The AHB clock for the SDHCn is enabled.

**Bit 14 – GMAC** GMAC AHB Clock Enable

Value	Description
0	The AHB clock for the GMAC is stopped.
1	The AHB clock for the GMAC is enabled.

**Bit 13 – QSPI** QSPI AHB Clock Enable

Value	Description
0	The AHB clock for the QSPI is stopped.
1	The AHB clock for the QSPI is enabled.

**Bit 12 – PAC** PAC AHB Clock Enable

Value	Description
0	The AHB clock for the PAC is stopped.
1	The AHB clock for the PAC is enabled.

**Bits 11,7,5 – Reserved** Reserved bits

Reserved bits are unused and reserved for future use. For compatibility with future devices, always write reserved bits to their reset value. If no reset value is given, write 0.

**Bit 10 – USB** USB AHB Clock Enable

Value	Description
0	The AHB clock for the USB is stopped.
1	The AHB clock for the USB is enabled.

**Bit 9 – DMAC** DMAC AHB Clock Enable

Value	Description
0	The AHB clock for the DMAC is stopped.
1	The AHB clock for the DMAC is enabled.

**Bit 8 – CMCC** CMCC AHB Clock Enable

Value	Description
0	The AHB clock for the CMCC is stopped.
1	The AHB clock for the CMCC is enabled.

**Bit 6 – NVMCTRL** NVMCTRL AHB Clock Enable

Value	Description
0	The AHB clock for the NVMCTRL is stopped.
1	The AHB clock for the NVMCTRL is enabled.

**Bit 4 – DSU** DSU AHB Clock Enable

Value	Description
0	The AHB clock for the DSU is stopped.
1	The AHB clock for the DSU is enabled.

**Bits 0, 1, 2, 3 – HPBn** HPBn AHB Clock Enable

Value	Description
0	The AHB clock for the HPBn is stopped.



Value	Description
1	The AHB clock for the APBn is enabled.

## 16.6.7 APBA Mask

**Name:** APBAMASK  
**Offset:** 0x14  
**Reset:** 0x000007FF  
**Property:** PAC Write-Protection

Bit	31	30	29	28	27	26	25	24
Access								
Reset								
Bit	23	22	21	20	19	18	17	16
Access								
Reset								
Bit	15	14	13	12	11	10	9	8
Access	TC1	TC0	SERCOM1	SERCOM0	FREQM	EIC	RTC	WDT
Reset	R/W	R/W	R/W	R/W	R/W	R/W	R/W	R/W
Reset	0	0	0	0	0	1	1	1
Bit	7	6	5	4	3	2	1	0
Access	GCLK	SUPC	OSC32KCTRL	OSCCTRL	RSTC	MCLK	PM	PAC
Reset	R/W	R/W	R/W	R/W	R/W	R/W	R/W	R/W
Reset	1	1	1	1	1	1	1	1

### Bits 14, 15 – TCn TCn APBA Clock Enable

Value	Description
0	The APBA clock for the TCn is stopped.
1	The APBA clock for the TCn is enabled.

### Bits 12, 13 – SERCOM SERCOMn APBA Clock Enable

Value	Description
0	The APBA clock for the SERCOMn is stopped.
1	The APBA clock for the SERCOMn is enabled.

### Bit 11 – FREQM FREQM APBA Clock Enable

Value	Description
0	The APBA clock for the FREQM is stopped.
1	The APBA clock for the FREQM is enabled.

### Bit 10 – EIC EIC APBA Clock Enable

Value	Description
0	The APBA clock for the EIC is stopped.
1	The APBA clock for the EIC is enabled.

### Bit 9 – RTC RTC APBA Clock Enable

Value	Description
0	The APBA clock for the RTC is stopped.
1	The APBA clock for the RTC is enabled.

### Bit 8 – WDT WDT APBA Clock Enable

Value	Description
0	The APBA clock for the WDT is stopped.
1	The APBA clock for the WDT is enabled.

**Bit 7 – GCLK** GCLK APBA Clock Enable

Value	Description
0	The APBA clock for the GCLK is stopped.
1	The APBA clock for the GCLK is enabled.

**Bit 6 – SUPC** SUPC APBA Clock Enable

Value	Description
0	The APBA clock for the SUPC is stopped.
1	The APBA clock for the SUPC is enabled.

**Bit 5 – OSC32KCTRL** OSC32KCTRL APBA Clock Enable

Value	Description
0	The APBA clock for the OSC32KCTRL is stopped.
1	The APBA clock for the OSC32KCTRL is enabled.

**Bit 4 – OSCCTRL** OSCCTRL APBA Clock Enable

Value	Description
0	The APBA clock for the OSCCTRL is stopped.
1	The APBA clock for the OSCCTRL is enabled.

**Bit 3 – RSTC** RSTC APBA Clock Enable

Value	Description
0	The APBA clock for the RSTC is stopped.
1	The APBA clock for the RSTC is enabled.

**Bit 2 – MCLK** MCLK APBA Clock Enable

Value	Description
0	The APBA clock for the MCLK is stopped.
1	The APBA clock for the MCLK is enabled.

**Bit 1 – PM** PM APBA Clock Enable

Value	Description
0	The APBA clock for the PM is stopped.
1	The APBA clock for the PM is enabled.

**Bit 0 – PAC** PAC APBA Clock Enable

Value	Description
0	The APBA clock for the PAC is stopped.
1	The APBA clock for the PAC is enabled.

## 16.6.8 APBB Mask

**Name:** APBBMASK  
**Offset:** 0x18  
**Reset:** 0x00018056  
**Property:** PAC Write-Protection

Bit	31	30	29	28	27	26	25	24
Access								
Reset								
Bit	23	22	21	20	19	18	17	16
Access								RAMECC
Reset								R/W 1
Bit	15	14	13	12	11	10	9	8
Access		TC3	TC2	TCC1	TCC0	SERCOM3	SERCOM2	
Reset		R/W 0	R/W 0	R/W 0	R/W 0	R/W 0	R/W 0	
Bit	7	6	5	4	3	2	1	0
Access	EVSYS			PORT		NVMCTRL	DSU	USB
Reset	R/W 0			R/W 1		R/W 1	R/W 1	R/W 0

### Bit 16 – RAMECC RAMECC APBB Clock Enable

Value	Description
0	The APBB clock for the RAMECC is stopped.
1	The APBB clock for the RAMECC is enabled.

### Bits 13, 14 – TCn TCn APBB Clock Enable

Value	Description
0	The APBB clock for the TCn is stopped.
1	The APBB clock for the TCn is enabled.

### Bits 11, 12 – TCCn TCCn APBB Clock Enable

Value	Description
0	The APBB clock for the TCCn is stopped.
1	The APBB clock for the TCCn is enabled.

### Bits 9, 10 – SERCOMn SERCOMn APBB Clock Enable

Value	Description
0	The APBB clock for the SERCOMn is stopped.
1	The APBB clock for the SERCOMn is enabled.

### Bit 7 – EVSYS EVSYS APBB Clock Enable

Value	Description
0	The APBB clock for the EVSYS is stopped.
1	The APBB clock for the EVSYS is enabled.

### Bit 4 – PORT PORT APBB Clock Enable

Value	Description
0	The APBB clock for the PORT is stopped.
1	The APBB clock for the PORT is enabled.

**Bit 2 - NVMCTRL** NVMCTRL APBB Clock Enable

Value	Description
0	The APBB clock for the NVMCTRL is stopped.
1	The APBB clock for the NVMCTRL is enabled.

**Bit 1 - DSU** DSU APBB Clock Enable

Value	Description
0	The APBB clock for the DSU is stopped.
1	The APBB clock for the DSU is enabled.

**Bit 0 - USB** USB APBB Clock Enable

Value	Description
0	The APBB clock for the USB is stopped.
1	The APBB clock for the USB is enabled.

## 16.6.9 APBC Mask

**Name:** APBCMASK  
**Offset:** 0x1C  
**Reset:** 0x00002000  
**Property:** PAC Write-Protection

Bit	31	30	29	28	27	26	25	24
Access								
Reset								
Bit	23	22	21	20	19	18	17	16
Access								
Reset								
Bit	15	14	13	12	11	10	9	8
Access		CCL	QSPI		ICM	TRNG	AES	AC
Reset		R/W	R/W		R/W	R/W	R/W	R/W
Reset		0	1		0	0	0	0
Bit	7	6	5	4	3	2	1	0
Access	PDEC	TC5	TC4	TCC3	TCC2	GMAC		
Reset	R/W	R/W	R/W	R/W	R/W	R/W		
Reset	0	0	0	0	0	0		

### Bit 14 – CCL CCL APBC Mask Clock Enable

Value	Description
0	The APBC clock for the CCL is stopped.
1	The APBC clock for the CCL is enabled.

### Bit 13 – QSPI QSPI APBC Mask Clock Enable

Value	Description
0	The APBC clock for the QSPI is stopped.
1	The APBC clock for the QSPI is enabled.

### Bit 11 – ICM ICM APBC Mask Clock Enable

Value	Description
0	The APBC clock for the ICM is stopped.
1	The APBC clock for the ICM is enabled.

### Bit 10 – TRNG TRNG APBC Mask Clock Enable

Value	Description
0	The APBC clock for the TRNG is stopped.
1	The APBC clock for the TRNG is enabled.

### Bit 9 – AES AES APBC Mask Clock Enable

Value	Description
0	The APBC clock for the AES is stopped.
1	The APBC clock for the AES is enabled.

### Bit 8 – AC AC APBC Mask Clock Enable

Value	Description
0	The APBC clock for the AC is stopped.
1	The APBC clock for the AC is enabled.

**Bit 7 - PDEC** PDEC APBC Mask Clock Enable

Value	Description
0	The APBC clock for the PDEC is stopped.
1	The APBC clock for the PDEC is enabled.

**Bits 5, 6 - TCn** TCn APBC Mask Clock Enable

Value	Description
0	The APBC clock for the TCn is stopped.
1	The APBC clock for the TCn is enabled.

**Bits 3, 4 - TCCn** TCCn APBC Mask Clock Enable

Value	Description
0	The APBC clock for the TCCn is stopped.
1	The APBC clock for the TCCn is enabled.

**Bit 2 - GMAC** GMAC APBC Mask Clock Enable

Value	Description
0	The APBC clock for the GMAC is stopped.
1	The APBC clock for the GMAC is enabled.

## 16.6.10 APBD Mask

**Name:** APBDMASK  
**Offset:** 0x20  
**Reset:** 0x00000000  
**Property:** PAC Write-Protection

Bit	31	30	29	28	27	26	25	24
Access								
Reset								
Bit	23	22	21	20	19	18	17	16
Access								
Reset								
Bit	15	14	13	12	11	10	9	8
Access					PCC	I2S	DAC	ADC1
Reset					R/W	R/W	R/W	R/W
					0	0	0	0
Bit	7	6	5	4	3	2	1	0
Access	ADC0	TC7	TC6	TCC4	SERCOM7	SERCOM6	SERCOM5	SERCOM4
Reset	R/W	R/W	R/W	R/W	R/W	R/W	R/W	R/W
	0	0	0	0	0	0	0	0

### Bit 11 – PCC PCC APBD Mask Clock Enable

Value	Description
0	The APBD clock for the PCC is stopped.
1	The APBD clock for the PCC is enabled.

### Bit 10 – I2S I2S APBD Mask Clock Enable

Value	Description
0	The APBD clock for the I2S is stopped.
1	The APBD clock for the I2S is enabled.

### Bit 9 – DAC DAC APBD Mask Clock Enable

Value	Description
0	The APBD clock for the DAC is stopped.
1	The APBD clock for the DAC is enabled.

### Bits 7, 8 – ADCn ADCn APBD Mask Clock Enable

Value	Description
0	The APBD clock for the ADCn is stopped.
1	The APBD clock for the ADCn is enabled.

### Bits 5, 6 – TC TCn APBD Mask Clock Enable

Value	Description
0	The APBD clock for the TCn is stopped.
1	The APBD clock for the TCn is enabled.

### Bit 4 – TCC4 TCC4 APBD Mask Clock Enable



Value	Description
0	The APBD clock for the TCC4 is stopped.
1	The APBD clock for the TCC4 is enabled.

**Bits 0, 1, 2, 3 – SERCOMn SERCOMn APBD Mask Clock Enable**

Value	Description
0	The APBD clock for the SERCOMn is stopped.
1	The APBD clock for the SERCOMn is enabled.

## 17. 32.768 kHz Oscillators Controller (OSC32KCTRL)

### 17.1 Overview

The 32 kHz Oscillators Controller (OSC32KCTRL) provides a user interface to the 32.768 kHz oscillators: XOSC32K and OSCULP32K.

The OSC32KCTRL sub-peripherals can be enabled, disabled, calibrated, and monitored through interface registers.

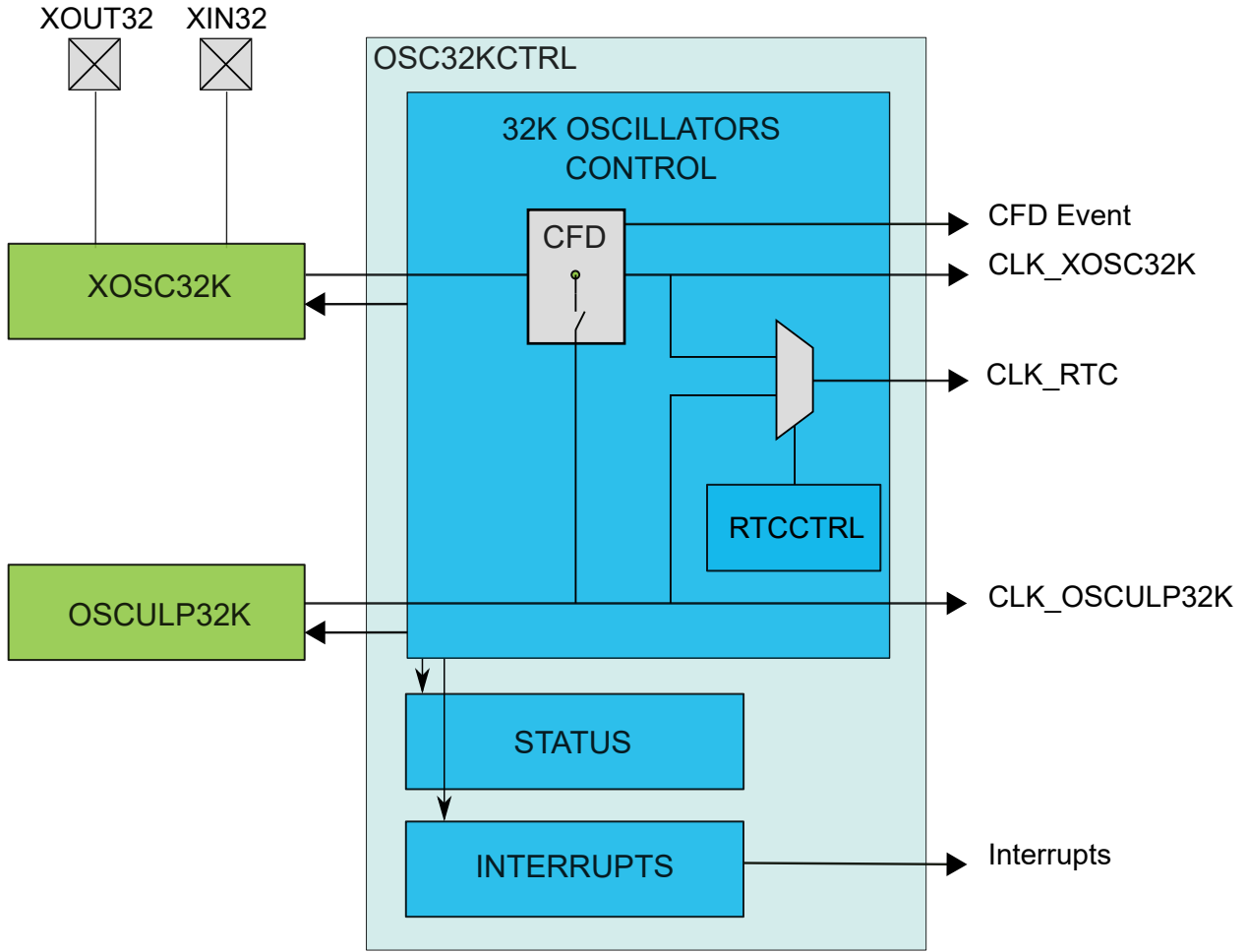
All sub-peripheral statuses are collected in the Status register (STATUS). They can additionally trigger interrupts upon status changes through the INTENSET, INTENCLR, and INTFLAG registers.

### 17.2 Features

The following are key features of the OSC32KCTRL:

- 32.768 kHz Crystal Oscillator (XOSC32K)
  - Programmable start-up time
  - Crystal or external input clock on XIN32 I/O
  - Clock failure detection with safe clock switch
  - Clock failure event output
- 32.768 kHz Ultra Low-Power Internal Oscillator (OSCULP32K)
  - Ultra low-power, always-on oscillator
  - Frequency fine tuning
- Calibration value loaded from Flash factory calibration at Reset
- 1.024 kHz clock outputs available

### 17.3 Block Diagram



### 17.4 Signal Description

Signal	Description	Type
XIN32	Analog Input	32.768 kHz Crystal Oscillator or external clock input
XOUT32	Analog Output	32.768 kHz Crystal Oscillator output

The I/O lines are automatically selected when XOSC32K is enabled.

**Note:** The signal of the external crystal oscillator may affect the jitter of neighboring pads.

### 17.5 Peripheral Dependencies

<b>Peripheral Name</b>	OSC32KCTRL – 32768 kHz Oscillators Controller
<b>Base Address</b>	0x4000_1400 (Peripheral Bus A)
<b>NVIC IRQ Index:Source</b>	7 : XOSC32KFAIL, XOSC32KRDY
<b>MCLK APB Clock (1)</b>	CLK_OSC32KCTRL_APB, Enabled, APBAMASK.OSC32KCTRL
<b>GCLK Peripheral Channel Index:Clock Name</b>	n/a
<b>PAC Peripheral Identifier (PAC.WRCTRL)</b>	5
<b>Note:</b>	
1. Clock Name, Default State, Mask Field.	

### 17.5.1 I/O Lines

I/O lines are configured by OSC32KCTRL when XOSC32K is enabled and need no user configuration.

### 17.5.2 Power Management

The OSC32KCTRL will continue to operate in any sleep mode where a 32.768 kHz oscillator is running as source clock. The OSC32KCTRL interrupts can be used to wake up the device from sleep modes.

### 17.5.3 Clocks

The OSC32KCTRL gathers controls for both 32.768 kHz oscillators and provides clock sources to the [Generic Clock Controller \(GCLK\)](#), [Real-Time Counter \(RTC\)](#), and [Watchdog Timer \(WDT\)](#).

The available clock sources are: XOSC32K and OSCULP32K.

The OSC32KCTRL bus clock (CLK\_OSC32KCTRL\_APB) can be enabled and disabled in the [Main Clock module \(MCLK\)](#).

### 17.5.4 Debug Operation

When the CPU is halted in debug mode, OSC32KCTRL will continue normal operation. If OSC32KCTRL is configured in a way that requires it to be periodically serviced by the CPU through interrupts or similar, improper operation or data loss may result during debugging.

### 17.5.5 Register Access Protection

All registers with write access can be write-protected optionally by the [Peripheral Access Controller \(PAC\)](#), except for the following registers:

- Interrupt Flag Status and Clear (INTFLAG) register

Optional write protection by the [Peripheral Access Controller \(PAC\)](#) is denoted by the "PAC Write Protection" property in each individual register description.

PAC write protection does not apply to accesses through an external debugger.

### 17.5.6 Analog Connections

The external 32.768 kHz crystal must be connected between the XIN32 and XOUT32 pins, along with any required load capacitors. For details on recommended oscillator characteristics and capacitor load, refer to the Electrical Specifications.

## 17.6 Functional Description

### 17.6.1 Principle of Operation

XOSC32K and OSCULP32K are configured through OSC32KCTRL control registers. Through this interface, the sub-peripherals are enabled, disabled, or have their calibration values updated.

The STATUS register gathers different status signals coming from the sub-peripherals of OSC32KCTRL. The status signals can be used to generate system interrupts, and in some cases wake up the system from standby mode, provided the corresponding interrupt is enabled.

### 17.6.2 32 kHz External Crystal Oscillator (XOSC32K) Operation

The XOSC32K can operate in two different modes:

- External clock, with an external clock signal connected to XIN32
- Crystal oscillator, with an external 32.768 kHz crystal connected between XIN32 and XOUT32

At reset, the XOSC32K is disabled, and the XIN32/XOUT32 pins can either be used as General Purpose I/O (GPIO) pins or by other peripherals in the system.

When XOSC32K is enabled, the operating mode determines the GPIO usage. When in crystal oscillator mode, the XIN32 and XOUT32 pins are controlled by the OSC32KCTRL, and GPIO functions are overridden on both pins. When in external clock mode, only the XIN32 pin will be overridden and controlled by the OSC32KCTRL, while the XOUT32 pin can still be used as a GPIO pin.

<b>Enabling, Disabling</b>	The XOSC32K is enabled by writing a '1' to the Enable bit in the 32 kHz External Crystal Oscillator Control register (XOSC32K.ENABLE = 1). The XOSC32K is disabled by writing a '0' to the Enable bit in the 32 kHz External Crystal Oscillator Control register (XOSC32K.ENABLE = 0).
<b>Mode Selection</b>	To enable the XOSC32K in Crystal Oscillator mode, the XTALLEN bit in the 32 kHz External Crystal Oscillator Control register must be written (XOSC32K.XTALLEN = 1). If XOSC32K.XTALLEN is '0', the External Clock Input mode will be enabled.
<b>Gain Selection</b>	When a crystal oscillator is selected, a controllable gain is provided. Writing to the Control Gain Mode bit field (XOSC32K.CGM) will select a gain setting appropriate for the desired trade-off between low power and high speed.
<b>32KHz and 1KHz Output</b>	The XOSC32K 32.768 kHz output is enabled by setting the 32 kHz Output Enable bit in the 32 kHz External Crystal Oscillator Control register (XOSC32K.EN32K = 1). The XOSC32K also has a 1.024 kHz clock output. This is enabled by setting the 1 kHz Output Enable bit in the 32 kHz External Crystal Oscillator Control register (XOSC32K.EN1K = 1).
<b>Configuration Lock</b>	It is also possible to lock the XOSC32K configuration by setting the Write Lock bit in the 32 kHz External Crystal Oscillator Control register (XOSC32K.WRTLOCK = 1). If set, the XOSC32K configuration is locked until a Power-on Reset (POR) is detected.

The XOSC32K will behave differently in different sleep modes based on the settings of XOSC32K.RUNSTDBY, XOSC32K.ONDEMAND, and XOSC32K.ENABLE. If XOSC32KCTRL.ENABLE = 0, the XOSC32K will be always stopped. For XOSC32KCTRL.ENABLE = 1, this table is valid:

**Table 17-1. XOSC32K Sleep Behavior**

CPU Mode	XOSC32K. RUNSTDBY	XOSC32K. ONDEMAND	Sleep Behavior of XOSC32K and CFD
Active or Idle	-	0	Always run
Active or Idle	-	1	Run if requested by peripheral
Standby	1	0	Always run
Standby	1	1	Run if requested by peripheral
Standby	0	-	Run if requested by peripheral

As a crystal oscillator usually requires a very long start-up time, the 32 kHz External Crystal Oscillator will keep running across resets when XOSC32K.ONDEMAND = 0, except for Power-on Reset (POR). After a reset or when waking up from a Sleep mode where the XOSC32K was disabled, the XOSC32K will need time to stabilize on the correct frequency. This start-up time can be configured by changing the Oscillator Start-Up Time bit group (XOSC32K.STARTUP) in the 32 kHz External Crystal Oscillator Control register. During the start-up time, the oscillator output is masked to ensure that no unstable clock propagates to the digital logic.

Once the external clock or crystal oscillator is stable and ready to be used as a clock source, the XOSC32K Ready bit in the Status register is set (STATUS.XOSC32KRDY = 1). The transition of STATUS.XOSC32KRDY from '0' to '1' generates an interrupt if the XOSC32K Ready bit in the Interrupt Enable Set register is set (INTENSET.XOSC32KRDY = 1).

The XOSC32K can be used as a source for [Generic Clock Generators \(GCLK\)](#) or for the [Real-Time Counter \(RTC\)](#). Before enabling the GCLK or the RTC module, the corresponding oscillator output must be enabled (XOSC32K.EN32K or XOSC32K.EN1K) in order to ensure proper operation. In the same way, the GCLK or RTC modules must be disabled before the clock selection is changed. For details on RTC clock configuration, refer to [17.6.6. Real-Time Counter Clock Selection](#).

### 17.6.3 Clock Failure Detection Operation

The Clock Failure Detector (CFD) allows the user to monitor the external clock or crystal oscillator signal provided by the external oscillator (XOSC32K). The CFD detects failing operation of the XOSC32K clock with reduced latency, and supports switching to a safe clock source in case of clock failure. The user can also switch from the safe clock back to XOSC32K in case of recovery. The safe clock is derived from the OSCULP32K oscillator with a configurable prescaler. This supports configuring the safe clock to fulfill the operative conditions of the microcontroller.

In sleep modes, CFD operation is automatically disabled when the external oscillator is not requested by a peripheral. Refer to the Sleep Behavior table above when this is the case.

The user interface registers allow to enable, disable, and configure the CFD. The Status register provides status flags on failure and clock switch conditions. The CFD can optionally trigger an interrupt or an event when a failure is detected.

#### Clock Failure Detection

The CFD is reset only at Power-on Reset (POR). The CFD does not monitor the XOSC32K clock when the oscillator is disabled (XOSC32K.ENABLE = 0).

Before starting the CFD operation, the user must start and enable the safe clock source (OSCULP32K oscillator).

The CFD operation is started by writing a '1' to the CFD Enable bit in the External Oscillator Control register (CFDCTRL.CFDEN).

**Notes:** Disabling then re-enabling the Clock Failure Detector must be done as follows:

1. Disable the XOSC32K (XOSC32K.ENABLE = 0).
2. Disable the Clock Failure Detector (CFDCTRL.CFDEN = 0).
3. Re-enable the Clock Failure Detector (CFDCTRL.CFDEN = 1).
4. Re-enable the XOSC32K (XOSC32K.ENABLE = 1).

After starting or restarting the XOSC32K, the CFD does not detect failure until the start-up time has elapsed. The start-up time is configured by the Oscillator Start-Up Time in the External Multipurpose Crystal Oscillator Control register (XOSC32K.STARTUP). Once the XOSC32K Start-Up Time is elapsed, the XOSC32K clock is constantly monitored.

During a period of 4 safe clocks (monitor period), the CFD watches for a clock activity from the XOSC32K. There must be at least one rising and one falling XOSC32K clock edge during 4 safe clock periods to meet non-failure conditions. If no or insufficient activity is detected, the failure status is asserted: The Clock Failure Detector status bit in the Status register (STATUS.XOSC32KFAIL) and the Clock Failure Detector interrupt flag bit in the Interrupt Flag register (INTFLAG.XOSC32KFAIL) are set. If the XOSC32KFAIL bit in the Interrupt Enable Set register (INTENSET.XOSC32KFAIL) is set, an interrupt is generated as well. If the Event Output enable bit in the Event Control register (EVCTRL.CFDEO) is set, an output event is generated, too.

After a clock failure was issued the monitoring of the XOSC32K clock is continued, and the Clock Failure Detector status bit in the Status register (STATUS.XOSC32KFAIL) reflects the current XOSC32K activity.

#### Clock Switch

When a clock failure is detected, the XOSC32K clock is replaced by the safe clock in order to maintain an active clock during the XOSC32K clock failure. The safe clock source is the OSCULP32K oscillator clock. Both 32 kHz and 1 kHz outputs of the XOSC32K are replaced by the respective OSCULP32K 32 kHz and 1 kHz outputs. The safe clock source can be scaled down by a configurable prescaler to ensure that the safe clock frequency does not exceed the operating conditions selected by the application. When the XOSC32K clock is switched to the safe clock, the Clock Switch bit in the Status register (STATUS.XOSC32KSW) is set.

When the CFD has switched to the safe clock, the XOSC32K is not disabled. If desired, the application must take the necessary actions to disable the oscillator. The application must also take the necessary actions to configure the system clocks to continue normal operations. In the case the application can recover the XOSC32K, the application can switch back to the XOSC32K clock by writing a '1' to Switch Back Enable bit in the Clock Failure Control register (CFDCTRL.SWBACK). Once the XOSC32K clock is switched back, the Switch Back bit (CFDCTRL.SWBACK) is cleared by hardware.

**Note:** Entering Low-Power Sleep mode will not be possible if the clock switch back cannot complete due to a persistent failure. In this specific situation, disable the Clock Failure Detector (CFDCTRL.CFDEN = 0), which will also clear the CFDCTRL.SWBACK bit.

### Prescaler

The CFD has an internal configurable prescaler to generate the safe clock from the OSCULP32K oscillator. The prescaler size allows to scale down the OSCULP32K oscillator so the safe clock frequency is not higher than the XOSC32K clock frequency monitored by the CFD. The maximum division factor is 2.

The prescaler is applied on both outputs (32 kHz and 1 kHz) of the safe clock.

#### Example 17-1. Example

For an external crystal oscillator at 32 kHz and the OSCULP32K frequency is 32 kHz, the XOSC32K.CFDPRESC should be set to 0 for a safe clock of equal frequency.

### Event

If the Event Output Enable bit in the Event Control register (EVCTRL.CFDEO) is set, the CFD clock failure will be output on the Event Output. When the CFD is switched to the safe clock, the CFD clock failure will not be output on the Event Output.

### Sleep Mode

The CFD is halted depending on configuration of the XOSC32K and the peripheral clock request. For additional information, refer to the Sleep Behavior table above. The CFD interrupt can be used to wake up the device from sleep modes.

## 17.6.4 32.768 kHz Ultra Low-Power Internal Oscillator (OSCULP32K) Operation

The OSCULP32K provides a tunable, low-speed, and ultra low-power clock source.

**Note:** The OSCULP32K is factory calibrated under typical voltage and temperature conditions.

The OSCULP32K is enabled by default after a Power-on Reset (POR) and will always run except during POR.

Users can lock the OSCULP32K configuration by setting the Write Lock bit in the 32 kHz Ultra Low-Power Internal Oscillator Control register (OSCULP32K.WRTLOCK = 1). If set, the OSCULP32K configuration is locked until POR is detected.

The OSCULP32K can be used as a source for [Generic Clock Generators \(GCLK\)](#) or for the [Real-Time Counter \(RTC\)](#). To ensure proper operation, the GCLK or RTC modules must be disabled before the clock selection is changed.

## 17.6.5 Watchdog Timer Clock Selection

The [Watchdog Timer \(WDT\)](#) uses the internal 1.024 kHz OSCULP32K output clock. This clock is running all the time and internally enabled when requested by the WDT module.

## 17.6.6 Real-Time Counter Clock Selection

Before enabling the [RTC module](#), the RTC clock must be selected first. All oscillator outputs are valid as RTC clock. The selection is done in the RTC Control register (RTCCTRL). To ensure a proper operation, it is highly recommended to disable the RTC module first, before the RTC clock source selection is changed.

### 17.6.7 Interrupts

The OSC32KCTRL has the following interrupt sources:

- XOSC32KRDY - 32 kHz Crystal Oscillator Ready: A 0-to-1 transition on the STATUS.XOSC32KRDY bit is detected
- XOSC32KFAIL - Clock Failure Detector: A 0-to-1 transition on the STATUS.XOSC32KFAIL bit is detected

All these interrupts are synchronous wake-up source.

Each interrupt source has an interrupt flag associated with it. The interrupt flag in the Interrupt Flag Status and Clear register ([INTFLAG](#)) is set when the interrupt condition occurs. Each interrupt can be enabled individually by setting the corresponding bit in the Interrupt Enable Set register ([INTENSET](#)), and disabled by setting the corresponding bit in the Interrupt Enable Clear register ([INTENCLR](#)). An interrupt request is generated when the interrupt flag is set and the corresponding interrupt is enabled. The interrupt request remains active until the interrupt flag is cleared, the interrupt is disabled or the OSC32KCTRL is reset. Refer to the [INTFLAG](#) register for details on how to clear interrupt flags.

The OSC32KCTRL has one common interrupt request line for all the interrupt sources. The user must read the INTFLAG register to determine which interrupt condition is present. Refer to the [INTFLAG](#) register for details.

**Note:** Interrupts must be globally enabled for interrupt requests to be generated.

### 17.6.8 Events

The CFD can generate the following output event:

- Clock Failure Detector (XOSC32KFAIL): Generated when the Clock Failure Detector status bit is set in the Status register (STATUS.XOSC32KFAIL). The CFD event is not generated when the Clock Switch bit (STATUS.SWBACK) in the Status register is set.

Writing a '1' to an Event Output bit in the Event Control register (EVCTRL.CFDEO) enables the CFD output event. Writing a '0' to this bit disables the CFD output event. Refer to the Event System chapter for details on configuring the event system.



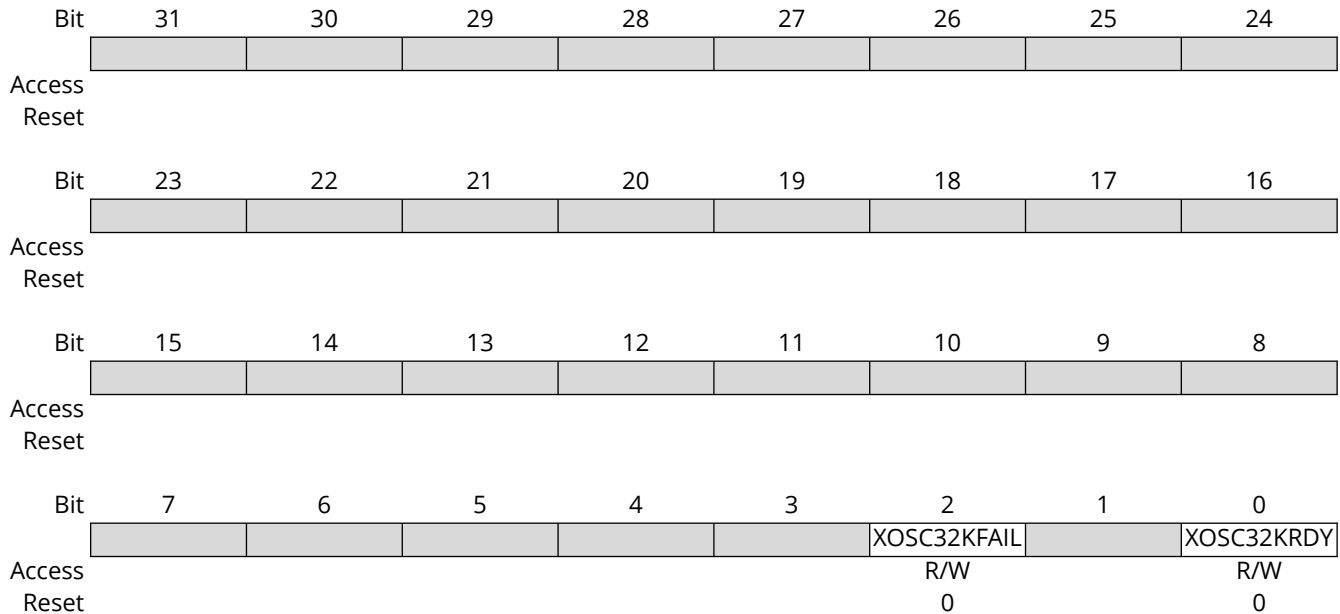
## 17.7 Register Summary

Offset	Name	Bit Pos.	7	6	5	4	3	2	1	0
0x00	INTENCLR	7:0						XOSC32KFAIL		XOSC32KRDY
		15:8								
		23:16								
		31:24								
0x04	INTENSET	7:0						XOSC32KFAIL		XOSC32KRDY
		15:8								
		23:16								
		31:24								
0x08	INTFLAG	7:0						XOSC32KFAIL		XOSC32KRDY
		15:8								
		23:16								
		31:24								
0x0C	STATUS	7:0					XOSC32KSW	XOSC32KFAIL		XOSC32KRDY
		15:8								
		23:16								
		31:24								
0x10	RTCCTRL	7:0						RTCSEL[2:0]		
0x11 ... 0x13	Reserved									
0x14	XOSC32K	7:0	ONDEMAND	RUNSTDBY		EN1K	EN32K	XTALEN	ENABLE	
		15:8		CGM[1:0]		WRTLOCK		STARTUP[2:0]		
0x16	CFDCTRL	7:0					CFDPRESC	SWBACK	CFDEN	
0x17	EVCTRL	7:0								CFDEO
0x18 ... 0x1B	Reserved									
0x1C	OSCULP32K	7:0						EN1K	EN32K	
		15:8	WRTLOCK		Reserved[5:0]					
		23:16								
		31:24								

### 17.7.1 Interrupt Enable Clear

**Name:** INTENCLR  
**Offset:** 0x00  
**Reset:** 0x00000000  
**Property:** PAC Write-Protection

This register allows the user to disable an interrupt without doing a read-modify-write operation. Changes in this register will also be reflected in the Interrupt Enable Set register (INTENSET).



#### Bit 2 – XOSC32KFAIL XOSC32K Clock Failure Detector Interrupt Enable

Writing a '0' to this bit has no effect.

Writing a '1' to this bit will clear the XOSC32K Clock Failure Interrupt Enable bit, which disables the XOSC32K Clock Failure interrupt.

Value	Description
0	The XOSC32K Clock Failure Detection is disabled.
1	The XOSC32K Clock Failure Detection is enabled. An interrupt request will be generated when the XOSC32K Clock Failure Detection interrupt flag is set.

#### Bit 0 – XOSC32KRDY XOSC32K Ready Interrupt Enable

Writing a '0' to this bit has no effect.

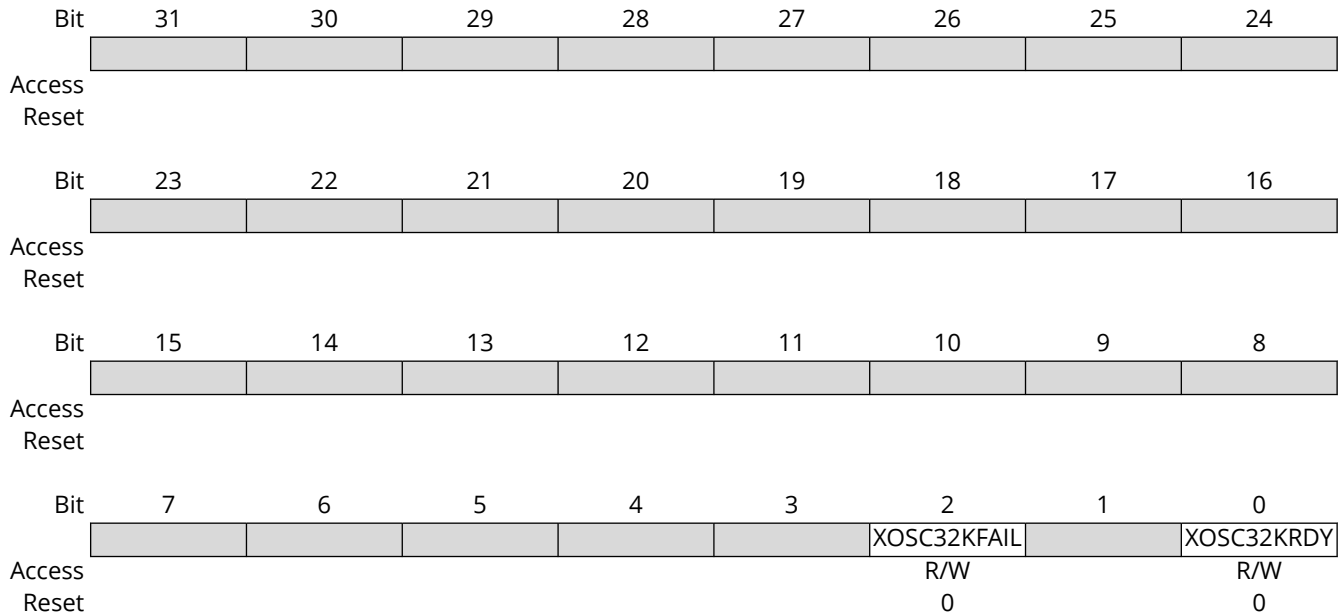
Writing a '1' to this bit will clear the XOSC32K Ready Interrupt Enable bit, which disables the XOSC32K Ready interrupt.

Value	Description
0	The XOSC32K Ready interrupt is disabled.
1	The XOSC32K Ready interrupt is enabled.

## 17.7.2 Interrupt Enable Set

**Name:** INTENSET  
**Offset:** 0x04  
**Reset:** 0x00000000  
**Property:** PAC Write-Protection

This register allows the user to disable an interrupt without doing a read-modify-write operation. Changes in this register will also be reflected in the Interrupt Enable Clear register (INTENCLR).



### Bit 2 – XOSC32KFAIL XOSC32K Clock Failure Detector Interrupt Enable

Writing a '0' to this bit has no effect.

Writing a '1' to this bit will set the XOSC32K Clock Failure Interrupt Enable bit, which enables the XOSC32K Clock Failure interrupt.

Value	Description
0	The XOSC32K Clock Failure Detection is disabled.
1	The XOSC32K Clock Failure Detection is enabled. An interrupt request will be generated when the XOSC32K Clock Failure Detection interrupt flag is set.

### Bit 0 – XOSC32KRDY XOSC32K Ready Interrupt Enable

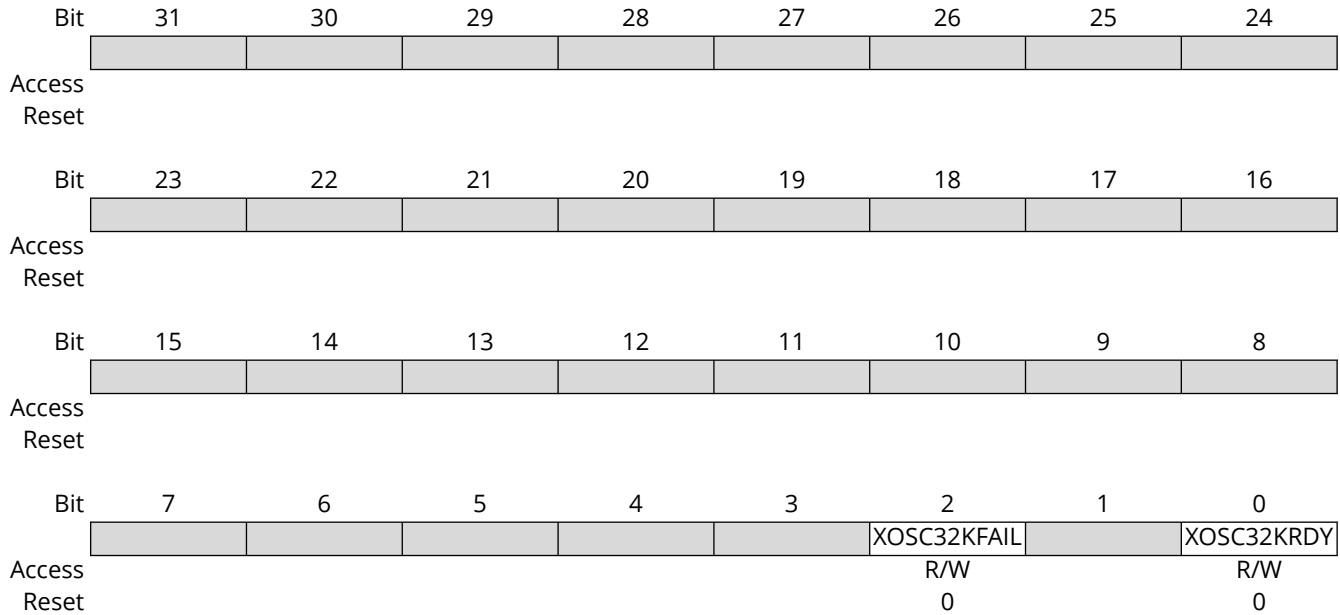
Writing a '0' to this bit has no effect.

Writing a '1' to this bit will set the XOSC32K Ready Interrupt Enable bit, which enables the XOSC32K Ready interrupt.

Value	Description
0	The XOSC32K Ready interrupt is disabled.
1	The XOSC32K Ready interrupt is enabled.

### 17.7.3 Interrupt Flag Status and Clear

**Name:** INTFLAG  
**Offset:** 0x08  
**Reset:** 0x00000000  
**Property:** -



#### Bit 2 - XOSC32KFAIL XOSC32K Clock Failure Detector

This flag is cleared by writing a '1' to it.

This flag is set on a zero-to-one transition of the XOSC32K Clock Failure Detection bit in the Status register (STATUS.XOSC32KFAIL) and will generate an interrupt request if INTENSET.XOSC32KFAIL is '1'.

Writing a '0' to this bit has no effect.

Writing a '1' to this bit will clear the XOSC32K Clock Failure Detection flag.

#### Bit 0 - XOSC32KRDY XOSC32K Ready

This flag is cleared by writing a '1' to it.

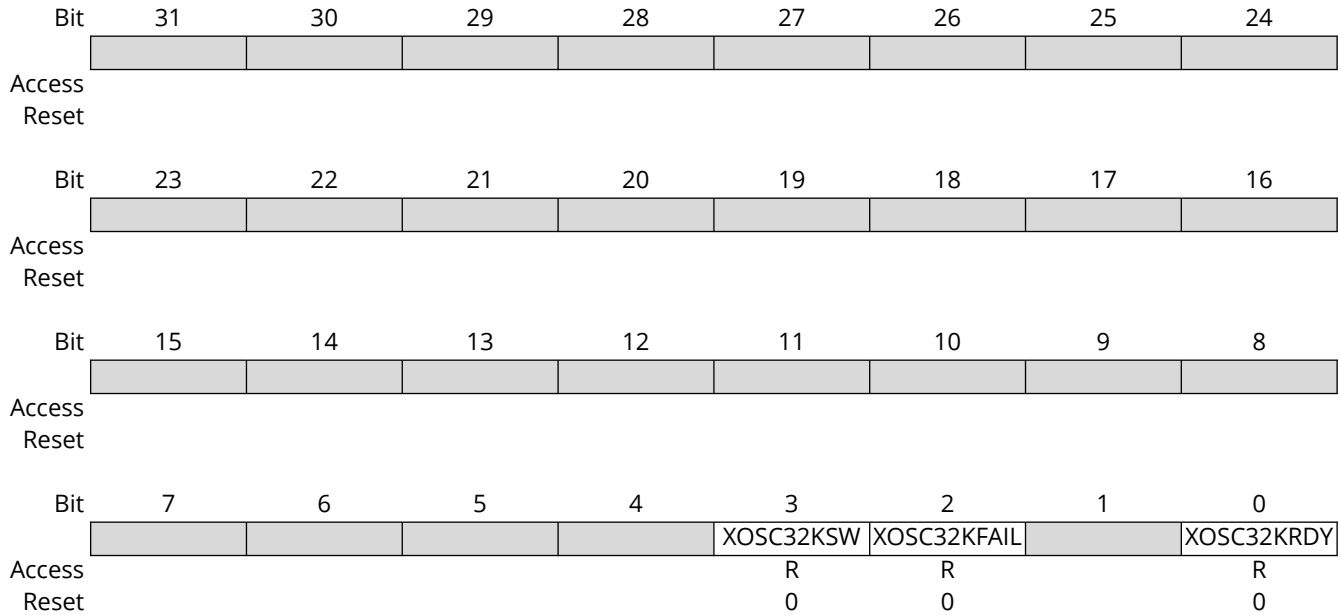
This flag is set by a zero-to-one transition of the XOSC32K Ready bit in the Status register (STATUS.XOSC32KRDY), and will generate an interrupt request if INTENSET.XOSC32KRDY=1.

Writing a '0' to this bit has no effect.

Writing a '1' to this bit clears the XOSC32K Ready interrupt flag.

## 17.7.4 Status

**Name:** STATUS  
**Offset:** 0x0C  
**Reset:** 0x00000000  
**Property:** -



### Bit 3 - XOSC32KSW XOSC32K Clock Switch

Value	Description
0	XOSC32K is not switched and provided the crystal oscillator.
1	XOSC32K is switched to be provided by the safe clock.

### Bit 2 - XOSC32KFAIL XOSC32K Clock Failure Detector

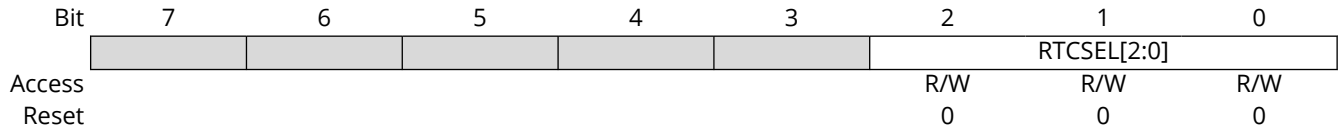
Value	Description
0	XOSC32K is passing failure detection.
1	XOSC32K is not passing failure detection.

### Bit 0 - XOSC32KRDY XOSC32K Ready

Value	Description
0	XOSC32K is not ready.
1	XOSC32K is stable and ready to be used as a clock source.

### 17.7.5 RTC Clock Selection Control

**Name:** RTCCTRL  
**Offset:** 0x10  
**Reset:** 0x00  
**Property:** PAC Write-Protection



**Bits 2:0 – RTCSEL[2:0]** RTC Clock Selection  
 These bits select the source for the RTC.

Value	Name	Description
0x0	ULP1K	1.024 kHz from 32 kHz internal ULP oscillator
0x1	ULP32K	32.768 kHz from 32 kHz internal ULP oscillator
0x2, 0x3	Reserved	-
0x4	XOSC1K	1.024 kHz from 32 kHz external oscillator
0x5	XOSC32K	32.768 kHz from 32 kHz external crystal oscillator
0x6	Reserved	
0x7	Reserved	

## 17.7.6 32 kHz External Crystal Oscillator (XOSC32K) Control

**Name:** XOSC32K  
**Offset:** 0x14  
**Reset:** 0x2080  
**Property:** PAC Write-Protection

Bit	15	14	13	12	11	10	9	8
		CGM[1:0]		WRTLOCK		STARTUP[2:0]		
Access		R/W	R/W	R/W		R/W	R/W	R/W
Reset		0	1	0		0	0	0
Bit	7	6	5	4	3	2	1	0
	ONDEMAND	RUNSTDBY		EN1K	EN32K	XTALEN	ENABLE	
Access	R/W	R/W		R/W	R/W	R/W	R/W	
Reset	1	0		0	0	0	0	

### Bits 14:13 – CGM[1:0] Control Gain Mode

These bits control the gain of the external crystal oscillator.

Value	Name	Description
0x1	XT	Standard mode
0x2	HS	High Speed mode

### Bit 12 – WRTLOCK Write Lock

This bit locks the XOSC32K register for future writes, effectively freezing the XOSC32K configuration.

Value	Description
0	The XOSC32K configuration is not locked.
1	The XOSC32K configuration is locked.

### Bits 10:8 – STARTUP[2:0] Oscillator Start-Up Time

These bits select the start-up time for the oscillator.

The OSCULP32K oscillator is used to clock the start-up counter.

**Table 17-2.** Start-Up Time for 32 kHz External Crystal Oscillator

STARTUP[2:0]	Number of OSCULP32K Clock Cycles	Number of XOSC32K Clock Cycles	Approximate Equivalent Time [ms]
0x0	2048	3	62.592
0x1	4096	3	125.092
0x2	16384	3	500.092
0x3	32768	3	1000.0092
0x4	65536	3	2000.0092
0x5	131072	3	4000.0092
0x6	262144	3	8000.0092
0x7	-	-	Reserved

#### Notes:

- Actual Start-Up time is 1 OSCULP32K cycle + 3 XOSC32K cycles.
- The given time assumes an XTAL frequency of 32.768 kHz.

### Bit 7 – ONDEMAND On Demand Control

This bit controls how the XOSC32K behaves when a peripheral clock request is detected. For details, refer to [Table 17-1](#).

**Bit 6 – RUNSTDBY** Run in Standby

This bit controls how the XOSC32K behaves during standby sleep mode. For details, refer to [Table 17-1](#).

**Bit 4 – EN1K** 1 kHz Output Enable

Value	Description
0	The 1.024 kHz output is disabled.
1	The 1.024 kHz output is enabled.

**Bit 3 – EN32K** 32 kHz Output Enable

Value	Description
0	The 32.768 kHz output is disabled.
1	The 32.768 kHz output is enabled.

**Bit 2 – XTALEN** Crystal Oscillator Enable

This bit controls the connections between the I/O pads and the external clock or crystal oscillator.

Value	Description
0	External clock connected on XIN32. XOUT32 can be used as general-purpose I/O.
1	Crystal connected to XIN32/XOUT32.

**Bit 1 – ENABLE** Oscillator Enable

Value	Description
0	The oscillator is disabled.
1	The oscillator is enabled.



### 17.7.7 Clock Failure Detector Control

**Name:** CFDCTRL  
**Offset:** 0x16  
**Reset:** 0x00  
**Property:** PAC Write-Protection

Bit	7	6	5	4	3	2	1	0
						CFDPRESC	SWBACK	CFDEN
Access						R/W	R/W	R/W
Reset						0	0	0

#### Bit 2 – CFDPRESC Clock Failure Detector Prescaler

This bit selects the prescaler for the Clock Failure Detector.

Value	Description
0	The CFD safe clock frequency is the OSCULP32K frequency
1	The CFD safe clock frequency is the OSCULP32K frequency divided by 2

#### Bit 1 – SWBACK Clock Switch Back

This bit controls the XOSC32K output switch back to the external clock or crystal scillator in case of clock recovery.

Value	Description
0	The clock switch is disabled.
1	The clock switch is enabled. This bit is reset when the XOSC32K output is switched back to the external clock or crystal oscillator.

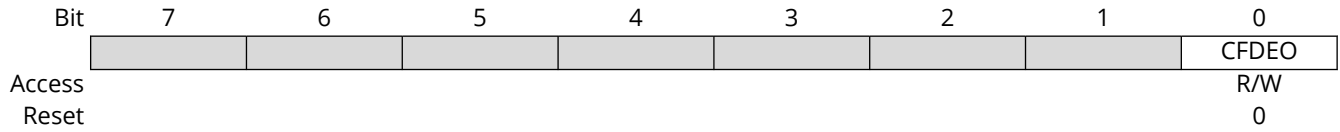
#### Bit 0 – CFDEN Clock Failure Detector Enable

This bit selects the Clock Failure Detector state.

Value	Description
0	The CFD is disabled.
1	The CFD is enabled.

### 17.7.8 Event Control

**Name:** EVCTRL  
**Offset:** 0x17  
**Reset:** 0x00  
**Property:** PAC Write-Protection



#### Bit 0 – CFDEO Clock Failure Detector Event Out Enable

This bit controls whether the Clock Failure Detector event output is enabled and an event will be generated when the CFD detects a clock failure.

Value	Description
0	Clock Failure Detector Event output is disabled, no event will be generated.
1	Clock Failure Detector Event output is enabled, an event will be generated.

### 17.7.9 32KHz Ultra Low Power Internal Oscillator (OSCULP32K) Control

**Name:** OSCULP32K  
**Offset:** 0x1C  
**Reset:** 0x00000000  
**Property:** PAC Write-Protection

Bit	31	30	29	28	27	26	25	24	
Access									
Reset									
Bit	23	22	21	20	19	18	17	16	
Access									
Reset									
Bit	15	14	13	12	11	10	9	8	
Access	R/W		Reserved[5:0]						
Reset	0		R/W	R/W	R/W	R/W	R/W	R/W	
Reset	0		0	0	0	0	0	0	
Bit	7	6	5	4	3	2	1	0	
Access						EN1K	EN32K		
Reset						R/W	R/W		
Reset						1	1		

#### Bit 15 – WRTLOCK Write Lock

This bit locks the OSCULP32K register for future writes to fix the OSCULP32K configuration.

Value	Description
0	The OSCULP32K configuration is not locked.
1	The OSCULP32K configuration is locked.

#### Bits 13:8 – Reserved[5:0]

These bits must not be changed to ensure correct OSCULP32K behavior.

#### Bit 2 – EN1K 1kHz Output Enable

Value	Description
0	The 1.024 kHz output is disabled
1	The 1.024 kHz output is enabled.

#### Bit 1 – EN32K

Value	Description
0	The 32.768 kHz output is disabled.
1	The 32.768 kHz output is enabled.

## 18. Oscillators Controller (OSCCTRL)

### 18.1 Overview

The Oscillators Controller (OSCCTRL) provides a user interface to the XOSCn, DFLL48M, and two FDPLL200Mn. Another clock controller (OSC32KCTRL) provides a user interface to 32.768 kHz oscillators.

Through the interface registers, it is possible to enable, disable, calibrate, and monitor the oscillators.

The status of all oscillators are collected in the Status register (STATUS). They can additionally trigger interrupts upon status changes via the INTENSET, INTENCLR, and INTFLAG registers.

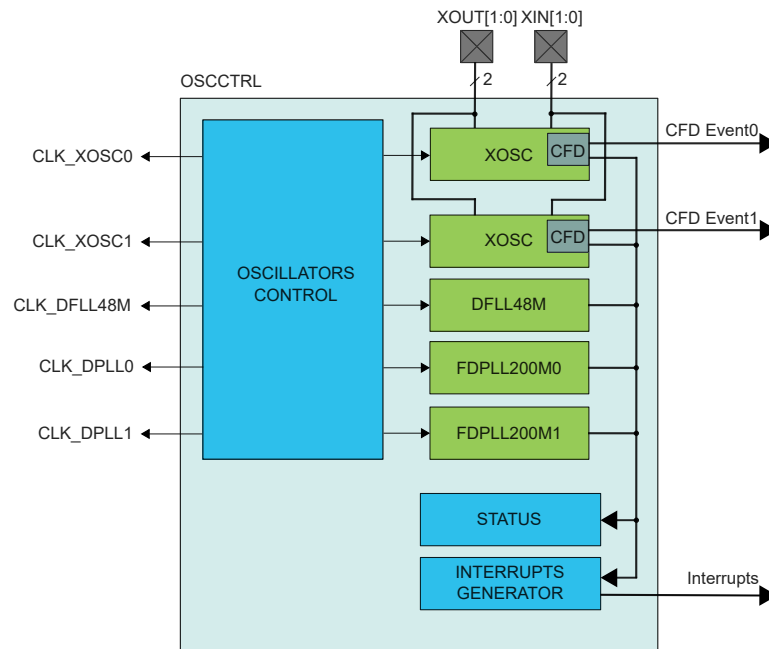
### 18.2 Features

The following are key features of the OSCCTRL:

- Digital Frequency-Locked Loop (DFLL48M)
  - Internal oscillator with no external components
  - 48 MHz output frequency
  - Operates stand-alone as a high-frequency programmable oscillator in Open-Loop mode
  - Operates as an accurate frequency multiplier against a known frequency in Closed-Loop mode
- Two 8-48 MHz Crystal Oscillators (XOSCn)
  - Tunable gain control
  - Programmable start-up time
  - Crystal or external input clock on XIN I/O
  - Clock failure detection with safe clock switch
  - Clock failure event output
- Two Digital Phase-Locked Loop (FDPLL200Mn)
  - 96 MHz to 200 MHz output frequency from a 32 kHz to 3.2 MHz reference clock
  - Two DPLLs, each with four selectable reference clocks
  - Adjustable digital filter for jitter optimization
  - Adjustable DCO filter for a 4-stages differential ring oscillator
  - Fractional part used to achieve 1/32th of reference clock step
  - Embedded test mode controller

## 18.3 Block Diagram

Figure 18-1. OSCCTRL Block Diagram



## 18.4 Signal Description

Signal	Description	Type
XIN[1:0]	Multipurpose Crystal Oscillator or external clock generator input	Analog input
XOUT[1:0]	Multipurpose Crystal Oscillator output	Analog output

The I/O lines are automatically selected when XOSCn is enabled.

## 18.5 Peripheral Dependencies

<b>Peripheral Name</b>	OSCCTRL – Oscillators Controller
<b>Base Address</b>	0x4000_1000 (Peripheral Bus A)
<b>NVIC IRQ Index:Source</b>	2 : XOSCFAIL0, XOSCRDY0 3 : XOSCFAIL1, XOSCRDY1 4 : DFLLLCKC, DFLLLCKF, DFLLLOOB, DFLLRCS, DFLLRDY 5 : DPLL0LCKF, DPLL0LCKR, DPLL0LDRTO, DPLL0LTO 6 : DPLL1LCKF, DPLL1LCKR, DPLL1LDRTO, DPLL1LTO
<b>MCLK APB Clock (1)</b>	CLK_OSCCTRL_APB, Enabled, APBAMASK.OSCCTRL
<b>GCLK Peripheral Channel Index:Clock Name</b>	n/a
<b>PAC Peripheral Identifier (PAC.WRCTRL)</b>	4
<b>Note:</b>	
1.	Clock Name, Default State, Mask Field.

### 18.5.1 I/O Lines

I/O lines are configured by OSCCTRL when XOSCn is enabled, and need no user configuration.

## 18.5.2 Power Management

The OSCCTRL can continue to operate in any sleep mode where the selected source clock is running. The OSCCTRL interrupts can be used to wake up the device from sleep modes. The events can trigger other operations in the system without exiting sleep modes.

## 18.5.3 Clocks

The OSCCTRL gathers controls for all device oscillators and provides clock sources to the Generic Clock Controller (GCLK). The available clock sources are: XOSCn, DFLL48M, and FDPLL200Mn.

The DFLL48M requires a reference clock (GCLK\_DFLL48M\_REF) from the GCLK. The control logic uses the oscillator output, which is also asynchronous to the user interface clock (CLK\_OSCCTRL\_APB). Due to this asynchronicity, writes to certain registers will require synchronization between the clock domains. Refer to [Synchronization](#) for further details.

The FDPLL200Mn require a reference clock (GCLK\_DPLL) for the FDPLL output. When the optional lock timer timeout function is used, a 32KHz reference clock (GCLK\_DPLL\_32K) is also required. Both reference clocks can either stem from the GCLK and/or from external oscillators.

## 18.5.4 Debug Operation

When the CPU is halted in debug mode the OSCCTRL continues normal operation. If the OSCCTRL is configured in a way that requires it to be periodically serviced by the CPU through interrupts or similar, improper operation or data loss may result during debugging.

## 18.5.5 Register Access Protection

All registers with write access can be write-protected optionally by the [Peripheral Access Controller \(PAC\)](#), except for the following registers:

- Interrupt Flag Status and Clear register (INTFLAG)
- DFLLULP Read Request register (DFLLULPRREQ)

**Note:** Optional write protection is indicated by the "PAC Write Protection" property in the register description.

Write protection does not apply for accesses through an external debugger.

## 18.5.6 Analog Connections

The 8-48 MHz crystal must be connected between the XIN and XOUT pins, along with any required load capacitors.

**Note:** Refer to the Electrical Characteristics for more information about load capacitors.

## 18.6 Functional Description

### 18.6.1 Principle of Operation

XOSC, DFLL48M, and FDPLL200Mn are configured through the OSCCTRL control registers. Through this interface, these oscillators are enabled, disabled, or have their calibration values updated.

The Status register gathers different status signals coming from the oscillators controlled by the OSCCTRL register. The status signals can be used to generate system interrupts, and in some cases wake up the system from Sleep mode, provided the corresponding interrupt is enabled.

### 18.6.2 External Multipurpose Crystal Oscillator (XOSCn) Operation

The XOSCn can operate in two different modes:

- External clock, with an external clock signal connected to the XIN pin
- Crystal oscillator, with an external 8-48 MHz crystal connected to the XIN and XOUT pins

The XOSCn can be used as a clock source for generic clock generators. This is configured by the [Generic Clock Controller\(GCLK\)](#).

At reset, the XOSCn is disabled, and the XINn/XOUTn pins can be used as General Purpose I/O (GPIO) pins or by other peripherals in the system. When XOSCn is enabled, the operating mode determines the GPIO usage. When in crystal oscillator mode, the XINn and XOUTn pins are controlled by the OSCCTRL, and GPIO functions are overridden on both pins. When in external clock mode, only the XINn pins will be overridden and controlled by the OSCCTRL, while the XOUTn pins can still be used as GPIO pins.

The XOSCn is enabled by writing a '1' to the Enable bit in the External Multipurpose Crystal Oscillator Control register (XOSCCTRLn.ENABLE). To enable XOSCn as an external crystal oscillator, the XTAL Enable bit (XOSCCTRLn.XTALEN) must be written to '1'. If XOSCCTRLn.XTALEN is zero, the external clock input on XIN will be enabled.

When in crystal oscillator mode (XOSCCTRLn.XTALEN=1), the External Multipurpose Crystal Oscillator Current Control (XOSCCTRLn.IPTAT, XOSCCTRLn.IMULT) must be set to match the external crystal oscillator frequency. If the External Multipurpose Crystal Oscillator Enable Amplitude Loop Control (XOSCCTRLn.ENALC) is '1', the oscillator amplitude will be automatically adjusted, and in most cases result in lower power consumption.

The bias current of the Crystal Oscillator can be adjusted to the desired value for a proper oscillation by setting the bit fields XOSCCTRLn.IPTAT and XOSCCTRLn.IMULT. See the recommended settings in [Table 18-7](#).

The low buffer gain is used to adjust the oscillator's amplitude in automatic loop control (XOSCCTRLn.ENALC=1). The default value of LOWBUFGAIN=0 should be used to allow operating with a low amplitude oscillator. The setting LOWBUFGAIN=1 can be used to solve stability issues. If set, the oscillator's amplitude is increased by a factor of approximately 2.

The XOSCn will behave differently in different sleep modes, based on the settings of XOSCCTRLn.RUNSTDBY, XOSCCTRLn.ONDEMAND, and XOSCCTRLn.ENABLE

**Table 18-1. XOSC Sleep Behavior**

XOSCCTRLn.RUNSTDBY	XOSCCTRLn.ONDEMAND	XOSCCTRLn.ENABLE	Sleep Behavior
-	-	0	Disabled
0	0	1	Always run in Idle Sleep modes. Run in Standby Sleep mode if requested by a peripheral.
0	1	1	Only run in Idle or Standby Sleep modes if requested by a peripheral.
1	0	1	Always run in Idle and Standby Sleep modes.
1	1	1	Only run in Idle or Standby Sleep modes if requested by a peripheral.

After a hard reset, or when waking up from a sleep mode where the XOSCn was disabled, the XOSCn will need a certain amount of time to stabilize on the correct frequency. This start-up time can be configured by changing the Oscillator Start-Up Time bit group (XOSCCTRLn.STARTUP) in the External Multipurpose Crystal Oscillator Control register. During the start-up time, the oscillator output is masked to ensure that no unstable clock propagates to the digital logic. The External Multipurpose Crystal Oscillator Ready bit in the Status register (STATUS.XOSCRDYn) is set when the external clock or crystal oscillator is stable and ready to be used as a clock source. An interrupt is generated on a zero-to-one transition on STATUS.XOSCRDYn if the External Multipurpose Crystal Oscillator Ready bit in the Interrupt Enable Set register (INTENSET.XOSCRDYn) is set.

### 18.6.3 Clock Failure Detection Operation

The Clock Failure Detector (CFD) allows the user to monitor the external clock or crystal oscillator clock signal provided by the External Multipurpose Crystal Oscillator (XOSCn). It detects failing operation of the XOSCn clock, and supports switching to a safe clock in case of clock failure. The user can also switch from the safe clock to the XOSCn clock in case of clock recovery. The safe clock is derived from the DFLL48M with a configurable prescaler. This supports configuring the safe clock in order to fulfill the operative conditions of the microcontroller. The CFD operation is automatically suspended when the XOSCn clock is not requested in ONDEMAND mode or halted in STANDBY.

The user interface registers allow to enable, disable and configure the CFD. The Status register gives status on failure and clock switch conditions. The Clock Failure Detector can optionally trigger an interrupt or an event when a failure is detected.

#### Clock Failure Detection

At reset, the CFD is disabled. The CFD does not monitor the XOSCn clock when the oscillator is disabled (XOSCCTRLn.ENABLE = 0).

Before starting the CFD operation, the user must start and enable the safe clock source (DFLL48M). To start the CFD operation, the user must write a one to the CFD Enable bit in the External Oscillator Control register (XOSCCTRLn.CFDEN).

**Notes:** Disabling then re-enabling the Clock Failure Detector must be done as follows:

1. Disable the XOSC (XOSCCTRLn.ENABLE = 0).
2. Disable the Clock Failure Detector (XOSCCTRLn.CFDEN = 0).
3. Re-enable the Clock Failure Detector (XOSCCTRLn.CFDEN = 1).
4. Re-enable the XOSC (XOSCCTRLn.ENABLE = 1).

After the start or restart of the XOSCn, the CFD does not detect failure until the start-up time, as configured by the Oscillator Start-Up Time (XOSCCTRLn.STARTUP) in the External Multipurpose Crystal Oscillator Control register, is elapsed. Once the XOSCn Start-Up Time is elapsed, the XOSCn clock is constantly monitored.

During a period of 4 safe clocks, the CFD watches for a clock activity from the XOSCn. There must be one rising and one falling XOSCn clock edges during a 4 safe clock periods to meet a non failure status. If no activity is detected, the failure status is asserted. The Clock Failure status bit in the Status register (STATUS.XOSCFAILn) is set. The Clock Failure interrupt flag bit in the Interrupt Flag register (INTFLAG.XOSCFAILn) is set. If the XOSCFAILn bit in the Interrupt Enable Set register (INTENSET.XOSCFAILn) is set, an interrupt is generated. An output event is generated as well, if the Event Output enable bit in the Event Control register (EVCTRL.CFDEOn) is set.

The XOSCn clock continues to be monitored after a clock failure. The Clock Failure status bit in the Status register (STATUS.XOSCFAILn) reflects the current XOSCn clock activity.

**Note:** The XOSC Ready bit (STATUS.XOSCRDY) must be ignored when a clock failure is detected: STATUS.XOSCFAIL must always be checked before STATUS.XOSCRDY, and STATUS.XOSCRDY must always be ignored when STATUS.XOSCFAIL=1.

#### Clock Switch

When a clock failure is detected, the XOSCn clock is replaced by the safe clock in order to maintain an active clock during the XOSCn clock failure. The safe clock source is the DFLL48M oscillator clock. The safe clock source can be downscaled with a configurable prescaler to ensure that the safe clock frequency does not exceed the operating conditions selected by the application. When the XOSCn clock is switched to the safe clock, the Clock Switch bit (STATUS.XOSCCKSWn) in the Status register is set.

When the CFD has switched to the safe clock, the XOSCn is not disabled. The application must take the necessary actions to disable the oscillator N. The application must also take the necessary actions to configure the system clocks to continue normal operations.



In the case the application can recover the XOSCn , it can switch back to the XOSCn clock by writing a one to Switch Back bit (XOSCCTRLn.SWBEN) in the External Oscillator Control register. Once the XOSCn clock is switched back, the Switch Back bit (XOSCCTRLn.SWBEN) is cleared by the hardware.

**Note:** Entering Low-Power Sleep mode will not be possible if the clock switch back cannot complete due to a persistent failure. In this specific situation, disable the Clock Failure Detector (XOSCCTRL.CFDEN = 0) which will also clear the XOSCCTRL.SWBEN bit.

### Prescaler

The CFD has an internal configurable prescaler (XOSCCTRLn.CFDPRESC) to generate the safe clock from the DFLL48M clock. The prescaler size allows to scale down the DFLL48M clock such that the safe clock is not higher than the XOSCn clock frequency monitored by the CFD. The frequency divider is  $2^{CFDPRESC}$  where CFDPRESC range from 0 to 15.

Example: for an external crystal oscillator at 8 mHz and the DFLL48M internal oscillator configured to generate a 48 mHz clock, the prescaler should select a downscale value above 6 (48/8), eg. 8, thus CFDPRESC=3.

### Event

If the Event Output enable bit in the Event Control register (EVCTRL.CFDEOn) is set, the CFD clock failure will be output on the Event Output. When the CFD is switched to the safe clock, the CFD clock failure will not be output on the Event Output.

### Sleep Mode

The CFD is halted depending on configuration of the XOSCn and the peripheral clock request. For further details, refer to the Sleep Behavior table above. The CFD interrupt can be used to wake up the device from sleep modes.

## 18.6.4 Digital Frequency Locked Loop (DFLL48M) Operation

The DFLL48M can operate in both open-loop mode and closed-loop mode. In closed-loop mode, a low-frequency clock with high accuracy should be used as the DFLL48M reference clock to get high accuracy on the output clock (CLK\_DFLL48M).



**Important:** The DFLL48M can only be used with LDO regulator.

The DFLL48M's output can be used as a source for the generic clock generators (GCLK.GENCTRLn.SRC = DFLL).

### 18.6.4.1 Basic Operation

#### Operating modes

The DFLL48M will behave differently in different sleep modes based on the settings of DFLLCTRLA.RUNSTDBY, DFLLCTRLA.ONDEMAND and DFLLCTRLA.ENABLE, as shown in the following table.

**Table 18-2.** DFLL48M Sleep Behavior

DFLLCTRLA.RUNSTDBY	DFLLCTRLA.ONDEMAND	DFLLCTRLA.ENABLE	Sleep Behavior
-	-	0	Disabled
0	0	1	Always run in Idle mode. Run in Standby mode if requested by a peripheral.
0	1	1	Only run in Idle or Standby mode if requested by a peripheral.

.....continued

DFLLCTRLA.RUNSTDBY	DFLLCTRLA.ONDEMAND	DFLLCTRLA.ENABLE	Sleep Behavior
1	0	1	Always run in Idle and Standby modes.
1	1	1	Only run in Idle or Standby mode if requested by a peripheral.

**Notes:**

1. Clear all DFLL48M INTFLAG Status flags before and after enabling the DFLL48M (DFLLCTRLA.ENABLE = 1).
2. When the DFLL48M is disabled (DFLLCTRLA.ENABLE = 0), clear the DFLLCTRLB.MODE bit to reset properly the lock bits of the DFLLSTATUS register.

The DFLL48M is used as a clock source for the generic clock generators, as described in the [GCLK](#) chapter.

The DFLL48M is factory-calibrated to provide 48 MHz in open loop mode. Registers DFLLVAL.COARSE and DFLLVAL.FINE store the factory frequency calibration values after reset.

**Open-Loop Operation**

After any reset, the Open-Loop mode is selected. When operating in Open-Loop mode, the output frequency of the DFLL48M will be determined by the values written to the DFLL Coarse Value bit group and the DFLL Fine Value bit group (DFLLVAL.COARSE and DFLLVAL.FINE) in the DFLL Value register.

It is possible to change the values of DFLLVAL.COARSE and DFLLVAL.FINE and thereby the output frequency of the DFLL48M output clock, CLK\_DFLL48M, while the DFLL48M is enabled and in use. CLK\_DFLL48M is ready to be used when STATUS.DFLLRDY is set after enabling the DFLL48M.

**Closed-Loop Operation**

In closed-loop operation, the output frequency is continuously regulated against a reference clock. Once the multiplication factor is set, the oscillator fine tuning is automatically adjusted. The DFLL48M must be configured before closed-loop operation can be enabled. After enabling the DFLL48M, it must be configured in the following way:

1. The output of Peripheral Channel 0 provides the input reference clock to DFLL48M (GCLK\_DFLL48M\_REF). Set GCLK.PCHCTRL0.GEN = 0 to select Generic Clock Channel 0 output as the input to this peripheral channel. Select the clock input to GCLK0 via GCLK.GENCTRL0.SRC.
2. Select the maximum step size allowed in finding the Coarse and Fine values by writing the appropriate values to the DFLL Coarse Maximum Step and DFLL Fine Maximum Step bit groups (DFLLMUL.CSTEP and DFLLMUL.FSTEP) in the DFLL Multiplier register. A small step size will ensure low overshoot on the output frequency, but will typically result in longer lock times. A high value might give a large overshoot, but will typically provide faster locking. DFLLMUL.CSTEP and DFLLMUL.FSTEP should not be higher than 50% of the maximum value of DFLLVAL.COARSE and DFLLVAL.FINE, respectively.
3. Select the multiplication factor in the DFLL Multiply Factor bit group (DFLLMUL.MUL) in the DFLL Multiplier register. Care must be taken when choosing DFLLMUL.MUL so that the output frequency does not exceed the maximum frequency of the device.
4. Start the Closed-Loop mode by writing a one to the DFLL Mode Selection bit (DFLLCTRLA.MODE) in the DFLL Control register.

The frequency of CLK\_DFLL48M (Fclkdfll48m) is given by:

$$F_{\text{clkdfll48m}} = \text{DFLLMUL.MUL} \times F_{\text{clkdfll48mref}}$$

where `Fckdfll48mref` is the frequency of the reference clock (`CLK_DFLL48M_REF`). `DFLLVAL.COARSE` and `DFLLVAL.FINE` are read-only in closed-loop mode, and are controlled by the frequency tuner to meet user specified frequency. In closed-loop mode, the value in `DFLLVAL.COARSE` is used by the frequency tuner as a starting point for Coarse. Writing `DFLLVAL.COARSE` to a value close to the final value before entering closed-loop mode will reduce the time needed to get a lock on Coarse.

### Frequency Locking

The locking of the frequency in closed-loop mode is divided into two stages. In the first, coarse stage, the control logic quickly finds the correct value for `DFLLVAL.COARSE` and sets the output frequency to a value close to the correct frequency. On coarse lock, the DPLL Locked on Coarse Value bit (`STATUS.DFLLCKC`) in the Status register will be set.

In the second, fine stage, the control logic tunes the value in `DFLLVAL.FINE` so that the output frequency is very close to the desired frequency. On fine lock, the DPLL Locked on Fine Value bit (`STATUS.DFLLCKF`) in the Status register will be set.

If the ByPass Lock bit (`DFLLCTRLB.BPLCKC`) in the DPLL Control register is set, the coarse stage is by-passed, the `DFLLVAL.COARSE` keeps its value and the DPLL Coarse Value bit (`STATUS.DFLLCKC`) is immediately set.

Interrupts are generated by both `STATUS.DFLLCKC` and `STATUS.DFLLCKF` if `INTENSET.DFLLCKC` or `INTENSET.DFLLCKF` are written to '1'.

`CLK_DFLL48M` is ready to be used when the DPLL Ready bit (`STATUS.DFLLRDY`) in the Status register is set, but the accuracy of the output frequency depends on which locks are set. For lock times, refer to the Electrical Characteristics.

**Note:** If `DFLLCTRLB.WAITLOCK = 1`, the `STATUS.DFLLRDY` will raise only when the fine lock bit (`STATUS.DFLLCKF`) has risen.

### Frequency Error Measurement

The ratio between `CLK_DFLL48M_REF` and `CLK48M_DFLL` is measured automatically when the DPLL48M is in closed loop mode. The difference between this ratio and the value in `DFLLMUL.MUL` is stored in the DPLL Multiplication Ratio Difference bit group (`DFLLVAL.DIFF`) in the DPLL Value register. The relative error on `CLK_DFLL48M` compared to the target frequency is calculated as follows:

$$\text{ERROR} = \frac{\text{DIFF}}{\text{MUL}}$$

### Drift Compensation

If the Stable DPLL Frequency bit (`DFLLCTRLB.STABLE`) in the DPLL Control register is zero, the frequency tuner will automatically compensate for drift in the `CLK_DFLL48M` without losing either of the locks. This means that `DFLLVAL.FINE` can change after every measurement of `CLK_DFLL48M`. If the `DFLLVAL.FINE` value overflows or underflows due to large drift in temperature and/or voltage, the DPLL Out Of Bounds bit (`STATUS.DFLLLOOB`) in the Status register will be set. After an Out of Bounds error condition, the user must rewrite `DFLLMUL.MUL` to ensure correct `CLK_DFLL48M` frequency. An interrupt is generated on a zero-to-one transition on `STATUS.DFLLLOOB` if the DPLL Out Of Bounds bit (`INTENSET.DFLLLOOB`) in the Interrupt Enable Set register is set. This interrupt will also be set if the tuner is not able to lock on the correct Coarse value. If the Stable DPLL Frequency bit (`DFLLCTRLB.STABLE`) in the DPLL Control register is one, the `DFLLVAL.COARSE` and `DFLLVAL.FINE` values will stay constant after the lock. The user can check for a possible drift by reading the frequency error in the DPLL Multiplication Ratio Difference bit group (`DFLLVAL.DIFF`).

### Reference Clock Stop Detection

If `CLK_DFLL48M_REF` stops or is running at a very low frequency (slower than  $\text{CLK\_DFLL48M}/(2 * \text{MULMAX})$ ), the DPLL Reference Clock Stopped bit (`STATUS.DFLLRCS`) in the Status register will be set. Detecting a stopped reference clock can take a long time, on the order of  $2^{17}$  `CLK_DFLL48M` cycles. When the reference clock is stopped, the DPLL48M will operate as if in open-loop mode. Closed-loop

mode operation will automatically resume if the CLK\_DFLL48M\_REF is restarted. An interrupt is generated on a zero-to-one transition on STATUS.DFLLRCS if the DFLL Reference Clock Stopped bit (INTENSET.DFLLRCS) in the Interrupt Enable Set register is set.

#### 18.6.4.2 Additional Features

##### Dealing with Delay in the DFLL in Closed-Loop Mode

The time from selecting a new CLK\_DFLL48M frequency until this frequency is output by the DFLL48M can be up to several microseconds. If the value in DFLLMUL.MUL is small, this can lead to instability in the DFLL48M locking mechanism, which can prevent the DFLL48M from achieving locks. To avoid this, a chill cycle, during which the CLK\_DFLL48M frequency is not measured, can be enabled. The chill cycle is enabled by default, but can be disabled by writing a one to the DFLL Chill Cycle Disable bit (DFLLCTRLB.CCDIS) in the DFLL Control register. Enabling chill cycles might double the lock time.

Another solution to this problem consists of using less strict lock requirements. This is called Quick Lock (QL), which is also enabled by default, but it can be disabled by writing a one to the Quick Lock Disable bit (DFLLCTRLB.QLDIS) in the DFLL Control register. The Quick Lock might lead to a larger spread in the output frequency than chill cycles, but the average output frequency is the same.

**Note:** During a maximum 30 cycles of the reference clock period, between lock flag asserted and frequency stabilization, DFLL accuracy will be limited. To minimize the cycle-to-cycle jitter during lock search, in addition to selecting a low step value (DFLLMUL.FSTEP, DFLLMUL.CSTEP), it is recommended to disable the Quick Lock feature.

##### USB Clock Recovery Mode

USB Clock Recovery mode can be used to create the 48 MHz USB clock from the USB Start Of Frame (SOF). This mode is enabled by writing a '1' to both the USB Clock Recovery Mode bit and the Mode bit in the DFLL Control register (DFLLCTRLB.USBCRM and DFLLCTRLB.MODE).

**Note:** The DFLLCTRLB.USBCRM register must not be set if the USB is disabled.

Changing the reference clock source (CLK\_DFLL\_REF) must be done as follows:

- Disable USB
- Switch the DFLL48M in open loop mode
- Change the reference clock (DFLLCTRLB.USBCRM)
- Switch the DFLL48M in close loop mode
- Enable USB

**Note:** When USB Clock Recovery mode is enabled, the GCLK DFLL48M reference clock (GCLK\_DFLL48M\_REF) must be disabled.

In USB Clock Recovery mode, the status bits of the DFLL in OSCCTRL.STATUS are determined by the USB bus activity, and have no valid meaning. The SOF signal from USB device will be used as reference clock (CLK\_DFLL\_REF), ignoring the selected generic clock reference. When the USB device is connected, a SOF will be sent every 1ms, thus DFLLVAL.MUX bits should be written to 0xBB80 to obtain a 48MHz clock. In USB clock recovery mode, the DFLLCTRLB.BPLCKC bit state is ignored, and the value stored in the DFLLVAL.COARSE will be used as final Coarse value.

The COARSE value for a calibrated 48 MHz frequency is loaded from NVM after any system reset and may vary in operating modes different of the USB Clock Recovery Mode. The initial COARSE value can be saved and restored by the software if necessary.

The locking procedure will also go instantaneously to the fine lock search.

The DFLLCTRLB.QLDIS bit must be cleared and DFLLCTRLB.CCDIS should be set to speed up the lock phase. The DFLLCTRLB.STABLE bit state is ignored, an auto jitter reduction mechanism is used instead.

## Wake from Sleep Modes

DFLL48M can optionally reset its lock bits when it is disabled. This is configured by the Lose Lock After Wake bit (DFLLCTRLB.LLAW) in the DFLL Control register.

If DFLLCTRLB.LLAW is zero, the DFLL48M will be re-enabled and start running with the same configuration as before being disabled, even if the reference clock is not available. The locks will not be lost. Thus it is important that the user checks that the DFLL48M has reached the COARSE and FINE lock stage before entering a sleep mode. When the reference clock has restarted, the Fine tracking will quickly compensate for any frequency drift during sleep if DFLLCTRLB.STABLE is zero.

If DFLLCTRLB.LLAW is one when disabling the DFLL48M, the DFLL48M will lose all its locks, and needs to regain these through the full lock sequence.

**Note:** When reconfiguring the DFLL, wait for the lock status to set to '0' (STATUS.DFLLLOCK = 0) after disabling the DFLL (DFLLCTRLA.ENABLE = 0).

The DFLLCTRLB.LLAW bit update must be done as follows:

1. Disable the DFLL (DFLLCTRLA.ENABLE = 0).
2. Wait for synchronization (DFLLSYNC.ENABLE = 0).
3. Wait for STATUS.DFLLRDY = 0.
4. Update the DFLLCTRLB.LLAW bit.

## Wait for Lock

DFLL48M can optionally control the issued clock. This is configured by the Wait For Lock bit (DFLLCTRLB.WAITLOCK) in the DFLL Control register. If DFLLCTRLB.WAITLOCK is zero, the DFLL48M will issue a clock immediately after the ready bit (STATUS.DFLLRDY) has risen. If DFLLCTRLB.WAITLOCK is one, the DFLL48M will issue a clock immediately after the fine lock bit (STATUS.DFLLCKF) has risen. Using the wait for lock feature allows a better accuracy of the issued DFLL48M clock, conversely it increases the startup time of the DFLL48M clock.

## Accuracy

There are two main factors that determine the accuracy of Fclkdfll48m. These can be tuned to obtain maximum accuracy when fine lock is achieved.

- Fine resolution: The frequency step between two Fine values.
- The accuracy of the reference clock.

### 18.6.5 Digital Phase Locked Loop (FDPLL200Mn) Operation

The task of the DPLL is to maintain coherence between the input (reference) signal and the respective output frequency CLK\_DPLL through phase comparison.



**Important:** The FDPLL200Mn can only be used with LDO regulator.

The DPLL controller supports four independent sources of reference clocks:

- **XOSC32K:** This clock is provided by the 32K External Crystal Oscillator (XOSC32K)
- **XOSC0 and XOSC1:** These clocks are provided by the External Multipurpose Crystal Oscillator (XOSC)
- **GCLK:** This clock is provided by the [Generic Clock Controller](#)

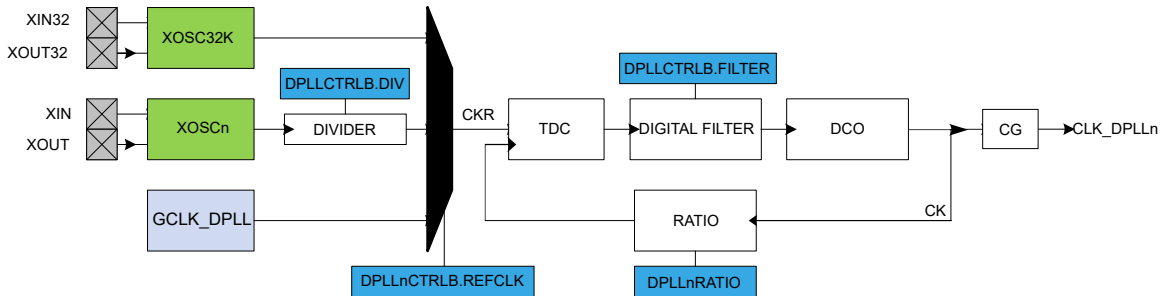
When the controller is enabled, the relationship between the reference clock frequency and the output clock frequency is as shown below:

$$f_{CLK\_DPLLn} = f_{CKR} \times \left( LDR + 1 + \frac{LDRFRAC}{32} \right)$$

Where:

$f_{CLK\_DPLLn}$  is the frequency of the DPLLn output clock, LDR is the loop divider ratio integer part and LDRFRAC is the loop divider ratio fractional part,  $f_{CKR}$  is the frequency of the selected reference clock.

**Figure 18-2.** DPLL Block Diagram



When the controller is disabled, the output clock is low. If the Loop Divider Ratio Fractional part bit field in the DPLL Ratio register (DPLLnRATIO.LDRFRAC) is zero, the DPLL works in Integer mode. Otherwise, the fractional mode is activated. The fractional part has a negative impact on the jitter of the DPLL.

For example (Integer mode only): Assuming  $f_{CKR} = 32$  kHz and  $f_{CLK\_DPLLn} = 112$  MHz, the multiplication ratio is 3500. It means that LDR must be set to 3499.

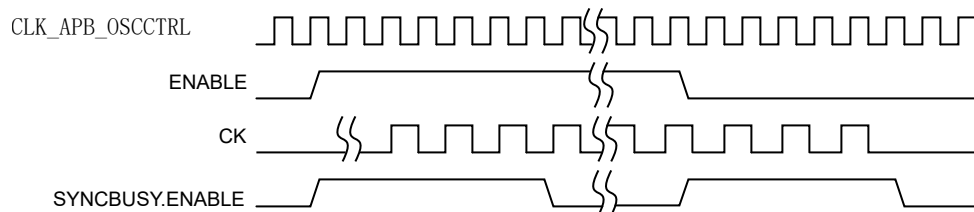
For example (Fractional mode): Assuming  $f_{CKR} = 32$  kHz and  $f_{CLK\_DPLLn} = 112.003000$  MHz, the multiplication ratio is 3500.9375 (3500 + 3/32). Thus LDR is set to 3499 and LDRFRAC to 3.

### 18.6.5.1 Basic Operation

#### Initialization, Enabling, Disabling, and Resetting

The DPLLn is enabled by writing a '1' to the Enable bit in the Control register (DPLLnCTRLA.ENABLE). The DPLLn is disabled by writing a '0' to DPLLnCTRLA.ENABLE. The DPLLnSYNCBUSY.ENABLE is set when the DPLLnCTRLA.ENABLE bit is modified. It is cleared when the DPLLn output clock CLK\_DPLLn has sampled the bit at the high level, or cleared when the output clock is no longer running (for disable operation).

**Figure 18-3.** Enable Synchronization Busy Operation



The frequency of the DPLLn output clock CLK\_DPLLn is stable when the module is enabled and when the LOCK bit is set. When DPLLnCTRLB.LTIME is different from 0, a user defined lock time is used to validate the lock operation. In that case the lock time is constant. If DPLLnCTRLB.LTIME is zero, the lock signal is linked with the status bit of the DPLLn (DPLLnSTATUS.LOCK), the lock time vary depending on the filter selection and final target frequency. When DPLLnCTRLB.WUF is set the

wake up fast mode is activated. In that mode the clock gating cell is enabled at the end of the startup time. At that time the final frequency is not stable as it is still the acquisition period, but it allows to save hundreds of microseconds. After the first acquisition, DPLLnCTRLB.LBYPASS indicates if the Lock signal is discarded from the control of the clock gater (CG) generating the output clock CLK\_DPLLn.

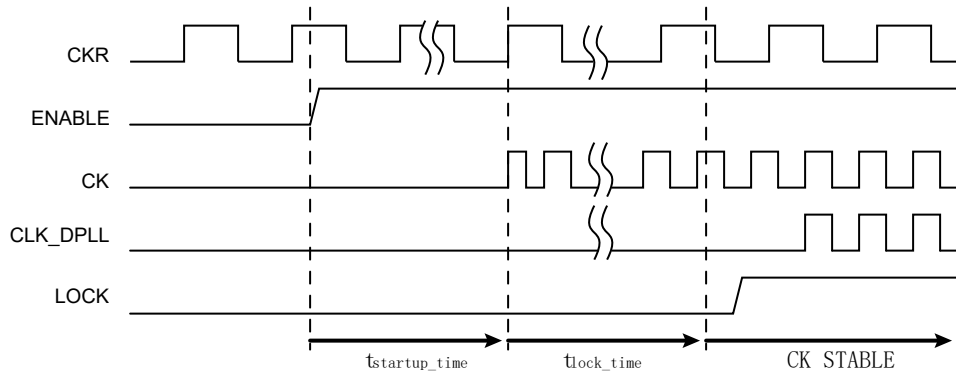
**Table 18-3.** CLK\_DPLLn Behavior from Startup to First Edge Detection.

WUF	LTIME	CLK_DPLLn Behavior
0	0	Normal Mode: First Edge when lock is asserted
0	Not Equal To Zero	Lock Timer Timeout mode: First Edge when the timer down-counts to 0.
1	X	Wake Up Fast Mode: First Edge when CK is active (startup time)

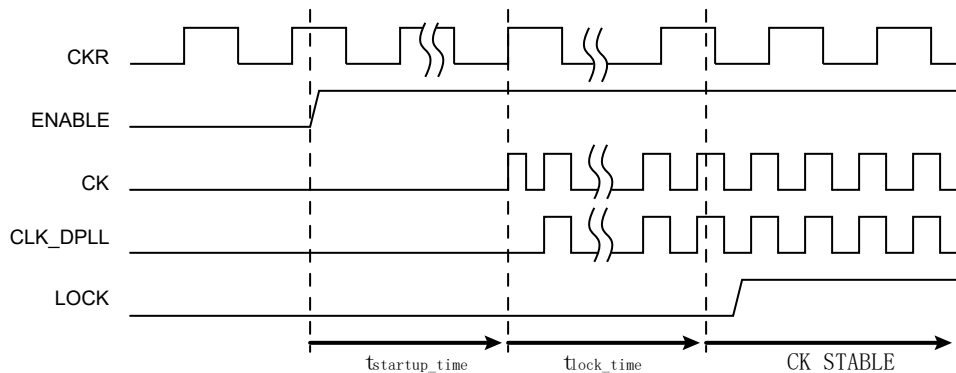
**Table 18-4.** CLK\_DPLLn Behavior After First Edge Detection.

LBYPASS	CLK_DPLLn Behavior
0	Normal Mode: the CLK_DPLLn is turned off when lock signal is low.
1	Lock Bypass Mode: the CLK_DPLLn is always running, lock is irrelevant.

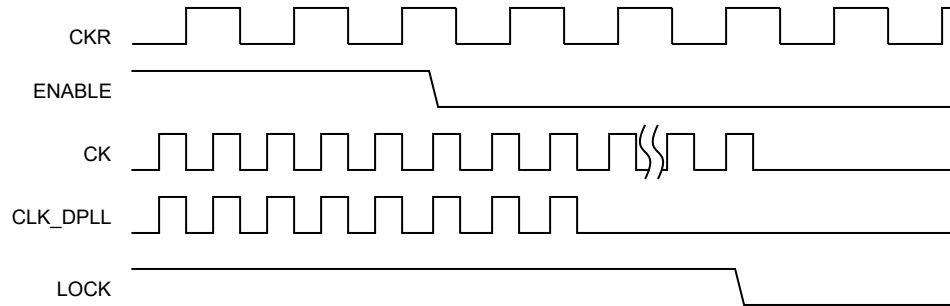
**Figure 18-4.** CK and CLK\_DPLL Output from DPLL Off Mode to Running Mode



**Figure 18-5.** CK and CLK\_DPLL Output from DPLL Off Mode to Running Mode When Wake Up Fast is Activated



**Figure 18-6.** CK and CLK\_DPLL Output from Running Mode to DPLL Off Mode.



### Operating Modes

The DPLL<sub>n</sub> will behave differently in different sleep modes based on the settings of DPLL<sub>n</sub>CTRLA.RUNSTDBY, DPLL<sub>n</sub>CTRLA.ONDEMAND and DPLL<sub>n</sub>CTRLA.ENABLE.

**Table 18-5.** DPLL Sleep Behavior

DPLLCTRLA.RUNSTDBY	DPLLCTRLA.ONDEMAND	DPLLCTRLA.ENABLE	Sleep Behavior
-	-	0	Disabled
0	0	1	Always run in Idle Sleep modes. Run in Standby Sleep mode if requested by a peripheral.
0	1	1	Only run in Idle or Standby Sleep modes if requested by a peripheral.
1	0	1	Always run in Idle and Standby Sleep modes.
1	1	1	Only run in Idle or Standby Sleep modes if requested by a peripheral.

### Reference Clock Switching

When a software operation requires reference clock switching, the normal operation is to disable the DPLL<sub>n</sub>, modify the DPLL<sub>n</sub>CTRLB.REFCLK to select the desired reference clock source and activate the DPLL<sub>n</sub> again. The CLK\_DPLL<sub>n</sub> output clock is ready when DPLL<sub>n</sub>STATUS.CLKRDY bit is set.

### XOSC Reference Clock Divider

DPLL<sub>n</sub>CTRLB.DIV[10:0] bits are used to set the XOSC clock division factor and can be calculated with following formula:

$$f_{DIV} = \frac{f_{XOSC}}{2 \times (DIV + 1)}$$

For more information, refer to DPLL<sub>n</sub>CTRLB.

### Loop Divider Ratio Updates

The DPLL<sub>n</sub> Controller supports on-the-fly update of the DPLL<sub>n</sub>RATIO register, so it is allowed to modify the loop divider ratio and the loop divider ratio fractional part when the DPLL<sub>n</sub> is enabled. Ensure the following conditions, or else the on-the-fly updating of the divider ratio will fail:

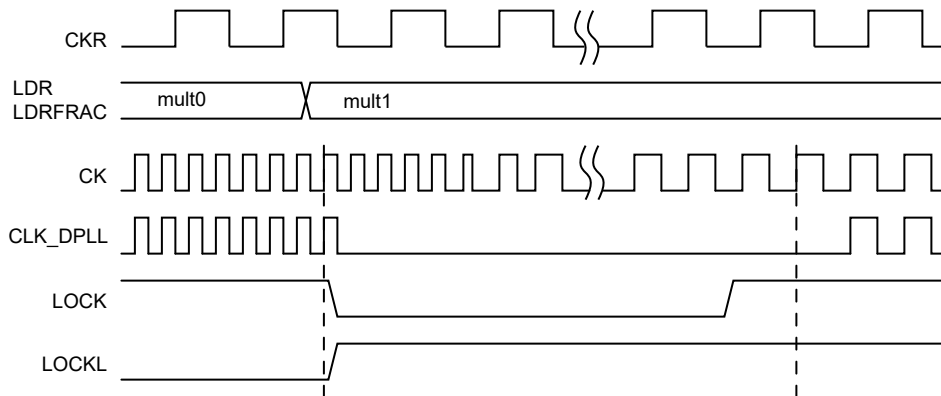
- DPLL<sub>n</sub>CTRLB.LBYPASS must be '0' (normal mode).
- DPLL<sub>n</sub>CTRLB.LTIME must not be 0x0, which is the default value.
- A DPLL<sub>n</sub> 32KHz clock (GCLK\_DPLL<sub>n</sub>\_32K) is configured in the GCLK peripheral as the internal lock timer.

Write DPLL<sub>n</sub>RATIO.LDR[12:0] bits to set the integer part of the frequency multiplier, and write DPLL<sub>n</sub>RATIO.LDRFRAC[4:0] bits to set the fractional part of the frequency multiplier.



Due to synchronization there is a delay between writing to `DPLLnRATIO.LDRFRAC[4:0]` or `DPLLnRATIO.LDR[12:0]` and the effect on the `DPLLn` output clock. The value written `DPLLnRATIO.LDRFAC[4:0]` or `DPLLnRATIO.LDR[12:0]` will be read back immediately, and the `DPLLnRATIO` bit in the synchronization busy register `DPLLnSYNCBUSY.DPLLnRATIO`, will be set. `DPLLnSYNCBUSY.DPLLnRATIO` will be cleared when the operation is completed. At that time the `DPLLnSTATUS.LOCK` bit is cleared and set again by hardware when the output frequency reached a stable state. Note that if only the fractional part of loop divider ratio (`DPLLnRATIO.LDRFRAC`) is updated, the lock status (`DPLLnSTATUS.LOCK`) will not be cleared.

**Figure 18-7.** RATIOCTRL Register Update Operation



### Digital Filter Selection

The digital filter selection can be changed from the filter selection register `DPLLnCTRLB.FILTER`. The `DPLL` digital filter coefficients are automatically adjusted in order to provide a good compromise between stability and jitter. For more information, refer to `DPLLnCTRLB`.

### Sigma-Delta DCO Filter Selection

The sigma-delta DAC low pass filter can be controlled and adjusted from the DCO filter selection register `DPLLnCTRLB.DCOFILTER[2:0]`. For more information, refer to `DPLLnCTRLB`.

## 18.6.6 Interrupts

The `OSCCTRL` has the following interrupt sources:

- `XOSCRDYN` - Multipurpose Crystal Oscillator Ready: A "0-to-1" transition on the `STATUS.XOSCRDY` bit is detected
- `XOSCFAILN` - Clock Failure . A "0-to-1" transition on the `STATUS.XOSCFAILN` bit is detected
- `DFLLRDY` - `DFLL48m` Ready: A "0-to-1" transition on the `STATUS.DFLLRDY` bit is detected
- `DFLLOOB` - `DFLL` Out of Bounds: A "0-to-1" transition on `STATUS.DFLLOOB` detected
- `DFLLCKF` - `DFLL` Lock Fine: A "0-to-1" transition on `STATUS.DFLLCKF` detected
- `DFLLCKC` - `DFLL` Lock Coarse: A "0-to-1" transition on `STATUS.DFLLCKC` detected
- `DPLLnLCKR` - `DPLLn` Lock Rise: A "0-to-1" transition on the `STATUS.DPLLnLCKR` bit is detected
- `DPLLnLCKF` - `DPLLn` Lock Fall: A "0-to-1" transition on the `STATUS.DPLLnLCKF` bit is detected
- `DPLLnLTTO` - `DPLLn` Lock Timer Time-out: A "0-to-1" transition on the `STATUS.DPLLnLTTO` bit is detected
- `DPLLnLDRTO` - `DPLLn` Loop Divider Ratio Update Complete

Each interrupt source has an interrupt flag associated with it. The interrupt flag in the Interrupt Flag Status and Clear register (`INTFLAG`) is set when the interrupt condition occurs. Each interrupt can be individually enabled by writing a one to the corresponding bit in the Interrupt Enable Set register (`INTENSET`), and disabled by writing a one to the corresponding bit in the Interrupt Enable

Clear register (INTENCLR). An interrupt request is generated when the interrupt flag is set and the corresponding interrupt is enabled. The interrupt request remains active until the interrupt flag is cleared, the interrupt is disabled, or the OSCCTRL is reset. INTFLAG register for details on how to clear interrupt flags.

The OSCCTRL has one common interrupt request line for all the interrupt sources. The user must read the INTFLAG register to determine which interrupt condition is present.

Note that interrupts must be globally enabled for interrupt requests to be generated.

### 18.6.7 Events

The Clock Failure Detector (CFD) can generate the following output event:

- Clock Failure (XOSCFAILn): Generated when the Clock Failure status bit is set in the Status register (STATUS.XOSCFAILn). The CFD event is not generated when a Clock Switch bit (STATUS.XOSCCKSWn) in the Status register is set.

Writing a '1' to an Event Output bit in the Event Control register (EVCTRL.CFDEOn) enables the CFD output event for XOSCn. Writing a '0' to this bit disables the CFD output event. Refer to the [Event System](#) chapter for details on configuring the event system.

### 18.6.8 Synchronization

Due to the multiple clock domains, some registers in the DFLL48M must be synchronized when accessed. A register can require:

- Synchronization when written
- Synchronization when read
- No synchronization

When executing an operation that requires synchronization, the relevant synchronization bit in the Synchronization Busy register (DFLLSYNC) will be set immediately, and cleared when synchronization is complete.

The following registers need synchronization:

- ENABLE bit in DFLLCTRLA register - write-synchronized
- DFLLCTRLB register - read-synchronized
- DFLLVAL register - read- and write-synchronized
- DFLLMUL register - write-synchronized

Due to the multiple clock domains (XOSC32K, XOSC, GCLK and CK), some registers in the DPLL must be synchronized when accessed. A register can require:

- Synchronization when written
- No synchronization

When executing an operation that requires synchronization, the relevant synchronization bit in the Synchronization Busy register (DPLLnSYNCBUSY) will be set immediately, and cleared when synchronization is complete.

The following bits need synchronization when written:

- Enable bit in control register A (DPLLnCTRLA.ENABLE)
- DPLLn Ratio register (DPLLnRATIO)

## 18.7 Register Summary

Offset	Name	Bit Pos.	7	6	5	4	3	2	1	0	
0x00	EVCTRL	7:0							CFDEO1	CFDEO0	
0x01	Reserved										
...											
0x03											
0x04	INTENCLR	7:0					XOSCFAIL1	XOSCFAIL0	XOSCRDY1	XOSCRDY0	
		15:8				DFLLRCS	DFLLLCKC	DFLLLCKF	DFLLOOB	DFLLRDY	
		23:16					DPLL0LDRTO	DPLL0LTO	DPLL0LCKF	DPLL0LCKR	
		31:24					DPLL1LDRTO	DPLL1LTO	DPLL1LCKF	DPLL1LCKR	
0x08	INTENSET	7:0					XOSCFAIL1	XOSCFAIL0	XOSCRDY1	XOSCRDY0	
		15:8				DFLLRCS	DFLLLCKC	DFLLLCKF	DFLLOOB	DFLLRDY	
		23:16					DPLL0LDRTO	DPLL0LTO	DPLL0LCKF	DPLL0LCKR	
		31:24					DPLL1LDRTO	DPLL1LTO	DPLL1LCKF	DPLL1LCKR	
0x0C	INTFLAG	7:0					XOSCFAIL1	XOSCFAIL0	XOSCRDY1	XOSCRDY0	
		15:8				DFLLRCS	DFLLLCKC	DFLLLCKF	DFLLOOB	DFLLRDY	
		23:16					DPLL0LDRTO	DPLL0LTO	DPLL0LCKF	DPLL0LCKR	
		31:24					DPLL1LDRTO	DPLL1LTO	DPLL1LCKF	DPLL1LCKR	
0x10	STATUS	7:0			XOSCKSW1	XOSCKSW0	XOSCFAIL1	XOSCFAIL0	XOSCRDY1	XOSCRDY0	
		15:8				DFLLRCS	DFLLLCKC	DFLLLCKF	DFLLOOB	DFLLRDY	
		23:16					DPLL0TO	DPLL0LCKF	DPLL0LCKR		
		31:24					DPLL1TO	DPLL1LCKF	DPLL1LCKR		
0x14	XOSCCTRL0	7:0	ONDEMAND	RUNSTDBY				XTALEN	ENABLE		
		15:8	ENALC		IMULT[3:0]				IPTAT[1:0]		LOWBUFGAIN
		23:16	STARTUP[3:0]						SWBEN	CFDEN	
		31:24						CFDPRESC[3:0]			
0x18	XOSCCTRL1	7:0	ONDEMAND	RUNSTDBY				XTALEN	ENABLE		
		15:8	ENALC		IMULT[3:0]				IPTAT[1:0]		LOWBUFGAIN
		23:16	STARTUP[3:0]						SWBEN	CFDEN	
		31:24						CFDPRESC[3:0]			
0x1C	DFLLCTRLA	7:0	ONDEMAND	RUNSTDBY				ENABLE			
0x1D	Reserved										
...											
0x1F											
0x20	DFLLCTRLB	7:0	WAITLOCK	BPLCKC	QLDIS	CCDIS	USBCRM	LLAW	STABLE	MODE	
0x21	Reserved										
...											
0x23											
0x24	DFLLVAL	7:0	FINE[7:0]								
		15:8	COARSE[5:0]								
		23:16	DIFF[7:0]								
		31:24	DIFF[15:8]								
0x28	DFLLMUL	7:0	MUL[7:0]								
		15:8	MUL[15:8]								
		23:16	FSTEP[7:0]								
		31:24	CSTEP[5:0]								
0x2C	DFLLSYNC	7:0				DFLLMUL	DFLLVAL	DFLLCTRLB	ENABLE		
0x2D	Reserved										
...											
0x2F											
0x30	DPLL0CTRLA	7:0	ONDEMAND	RUNSTDBY				ENABLE			
0x31	Reserved										
...											
0x33											
0x34	DPLLORATIO	7:0	LDR[7:0]								
		15:8						LDR[12:8]			
		23:16						LDRFRAC[4:0]			
		31:24									

.....continued

Offset	Name	Bit Pos.	7	6	5	4	3	2	1	0	
0x38	DPLL0CTRLB	7:0	REFCLK[2:0]			WUF	FILTER[3:0]				
		15:8	DCOEN	DCOFILTER[2:0]			LBYPASS	LTIME[2:0]			
		23:16	DIV[7:0]								
		31:24	DIV[10:8]								
0x3C	DPLL0SYNCBUSY	7:0						DPLL0RATIO	ENABLE		
		15:8									
		23:16									
		31:24									
0x40	DPLL0STATUS	7:0							CLKRDY	LOCK	
		15:8									
		23:16									
		31:24									
0x44	DPLL1CTRLA	7:0	ONDEMAND	RUNSTDBY					ENABLE		
0x45	Reserved										
...											
0x47											
0x48	DPLL1RATIO	7:0	LDR[7:0]								
		15:8							LDR[12:8]		
		23:16							LDRFRAC[4:0]		
		31:24									
0x4C	DPLL1CTRLB	7:0	REFCLK[2:0]			WUF	FILTER[3:0]				
		15:8	DCOEN	DCOFILTER[2:0]			LBYPASS	LTIME[2:0]			
		23:16	DIV[7:0]								
		31:24	DIV[10:8]								
0x50	DPLL1SYNCBUSY	7:0						DPLL1RATIO	ENABLE		
		15:8									
		23:16									
		31:24									
0x54	DPLL1STATUS	7:0							CLKRDY	LOCK	
		15:8									
		23:16									
		31:24									

### 18.7.1 Event Control

**Name:** EVCTRL  
**Offset:** 0x00  
**Reset:** 0x00  
**Property:** PAC Write-Protection

Bit	7	6	5	4	3	2	1	0
Access	R	R	R	R	R	R	R/W	R/W
Reset	0	0	0	0	0	0	0	0

#### Bits 0, 1 – CFDEO Clock n Failure Detector Event Output Enable [n=0,1]

This bit indicates whether the XOSC Clock Failure detector event output is enabled or not and an output event will be generated when the XOSC Clock Failure detector detects a clock failure.

0: Clock Failure detector event output is disabled and an event will not be generated.

1: Clock Failure detector event output is enabled and an event will be generated.

To prevent false event generation, the bit CFDEOn must be set or cleared only when the XOSCN is disabled (XOSCCTRLn.ENABLE=0).

## 18.7.2 Interrupt Enable Clear

**Name:** INTENCLR  
**Offset:** 0x04  
**Reset:** 0x00000000  
**Property:** PAC Write-Protection

This register allows the user to disable an interrupt without doing a read-modify-write operation. Changes in this register will also be reflected in the Interrupt Enable Set register (INTENSET).

Bit	31	30	29	28	27	26	25	24
					DPLL1LDRTO	DPLL1LTO	DPLL1LCKF	DPLL1LCKR
Access					R/W	R/W	R/W	R/W
Reset					0	0	0	0
Bit	23	22	21	20	19	18	17	16
					DPLL0LDRTO	DPLL0LTO	DPLL0LCKF	DPLL0LCKR
Access					R/W	R/W	R/W	R/W
Reset					0	0	0	0
Bit	15	14	13	12	11	10	9	8
				DFLLRCS	DFLLLCKC	DFLLLCKF	DFLLOOB	DFLLRDY
Access				R/W	R/W	R/W	R/W	R/W
Reset				0	0	0	0	0
Bit	7	6	5	4	3	2	1	0
					XOSCFAIL1	XOSCFAIL0	XOSCRDY1	XOSCRDY0
Access					R/W	R/W	R/W	R/W
Reset					0	0	0	0

### Bit 27 – DPLL1LDRTO DPLL1 Loop Divider Ratio Update Complete Interrupt Enable

0: The DPLL1 Loop Divider Ratio Update Complete interrupt is disabled.

1: The DPLL1 Loop Divider Ratio Update Complete interrupt is enabled, and an interrupt request will be generated when the DPLL1 Loop Divider Ratio Update Complete Interrupt flag is set.

Writing a zero to this bit has no effect.

Writing a '1' to this bit will clear the DPLL1 Loop Divider Ratio Update Complete Interrupt Enable bit, which disables the DPLL1 Loop Divider Ratio Update Complete interrupt.

### Bit 26 – DPLL1LTO DPLL1 Lock Timeout Interrupt Enable

0: The DPLL1 Lock Timeout interrupt is disabled.

1: The DPLL1 Lock Timeout interrupt is enabled, and an interrupt request will be generated when the DPLL1 Lock Timeout Interrupt flag is set.

Writing a zero to this bit has no effect.

Writing a '1' to this bit will clear the DPLL1 Lock Timeout Interrupt Enable bit, which disables the DPLL1 Lock Timeout interrupt.

### Bit 25 – DPLL1LCKF DPLL1 Lock Fall Interrupt Enable

0: The DPLL1 Lock Fall interrupt is disabled.

1: The DPLL1 Lock Fall interrupt is enabled, and an interrupt request will be generated when the DPLL1 Lock Fall Interrupt flag is set.

Writing a zero to this bit has no effect.

Writing a '1' to this bit will clear the DPLL1 Lock Fall Interrupt Enable bit, which disables the DPLL1 Lock Fall interrupt.

**Bit 24 – DPPLL1LCKR** DPPLL1 Lock Rise Interrupt Enable

0: The DPPLL1 Lock Rise interrupt is disabled.

1: The DPPLL1 Lock Rise interrupt is enabled, and an interrupt request will be generated when the DPPLL1 Lock Rise Interrupt flag is set.

Writing a zero to this bit has no effect.

Writing a '1' to this bit will clear the DPPLL1 Lock Rise Interrupt Enable bit, which disables the DPPLL1 Lock Rise interrupt.

**Bit 19 – DPPLL0LDRTO** DPPLL0 Loop Divider Ratio Update Complete Interrupt Enable

0: The DPPLL0 Loop Divider Ratio Update Complete interrupt is disabled.

1: The DPPLL0 Loop Divider Ratio Update Complete interrupt is enabled, and an interrupt request will be generated when the DPPLL0 Loop Divider Ratio Update Complete Interrupt flag is set.

Writing a zero to this bit has no effect.

Writing a '1' to this bit will clear the DPPLL0 Loop Divider Ratio Update Complete Interrupt Enable bit, which disables the DPPLL0 Loop Divider Ratio Update Complete interrupt.

**Bit 18 – DPPLL0LTO** DPPLL0 Lock Timeout Interrupt Enable

0: The DPPLL0 Lock Timeout interrupt is disabled.

1: The DPPLL0 Lock Timeout interrupt is enabled, and an interrupt request will be generated when the DPPLL0 Lock Timeout Interrupt flag is set.

Writing a zero to this bit has no effect.

Writing a '1' to this bit will clear the DPPLL0 Lock Timeout Interrupt Enable bit, which disables the DPPLL0 Lock Timeout interrupt.

**Bit 17 – DPPLL0LCKF** DPPLL0 Lock Fall Interrupt Enable

0: The DPPLL0 Lock Fall interrupt is disabled.

1: The DPPLL0 Lock Fall interrupt is enabled, and an interrupt request will be generated when the DPPLL0 Lock Fall Interrupt flag is set.

Writing a zero to this bit has no effect.

Writing a '1' to this bit will clear the DPPLL0 Lock Fall Interrupt Enable bit, which disables the DPPLL0 Lock Fall interrupt.

**Bit 16 – DPPLL0LCKR** DPPLL0 Lock Rise Interrupt Enable

0: The DPPLL0 Lock Rise interrupt is disabled.

1: The DPPLL0 Lock Rise interrupt is enabled, and an interrupt request will be generated when the DPPLL0 Lock Rise Interrupt flag is set.

Writing a zero to this bit has no effect.

Writing a '1' to this bit will clear the DPPLL0 Lock Rise Interrupt Enable bit, which disables the DPPLL0 Lock Rise interrupt.

**Bit 12 – DFLLRCS** DFLL Reference Clock Stopped Interrupt Enable

0: The DFLL Reference Clock Stopped interrupt is disabled.

1: The DFLL Reference Clock Stopped interrupt is enabled, and an interrupt request will be generated when the DFLL Reference Clock Stopped Interrupt flag is set.

Writing a zero to this bit has no effect.

Writing a '1' to this bit will clear the DFLL Reference Clock Stopped Interrupt Enable bit, which disables the DFLL Reference Clock Stopped interrupt.

**Bit 11 – DFLLLCKC** DFLL Lock Coarse Interrupt Enable

0: The DFLL Lock Coarse interrupt is disabled.

1: The DFLL Lock Coarse interrupt is enabled, and an interrupt request will be generated when the DFLL Lock Coarse Interrupt flag is set.

Writing a zero to this bit has no effect.

Writing a '1' to this bit will clear the DFLL Lock Coarse Interrupt Enable bit, which disables the DFLL Lock Coarse interrupt.

**Bit 10 – DFLLCKF** DFLL Lock Fine Interrupt Enable

0: The DFLL Lock Fine interrupt is disabled.

1: The DFLL Lock Fine interrupt is enabled, and an interrupt request will be generated when the DFLL Lock Fine Interrupt flag is set.

Writing a zero to this bit has no effect.

Writing a '1' to this bit will clear the DFLL Lock Fine Interrupt Enable bit, which disables the DFLL Lock Fine interrupt.

**Bit 9 – DFLOOB** DFLL Out Of Bounds Interrupt Enable

0: The DFLL Out Of Bounds interrupt is disabled.

1: The DFLL Out Of Bounds interrupt is enabled, and an interrupt request will be generated when the DFLL Out Of Bounds Interrupt flag is set.

Writing a zero to this bit has no effect.

Writing a '1' to this bit will clear the DFLL Out Of Bounds Interrupt Enable bit, which disables the DFLL Out Of Bounds interrupt.

**Note:** Check that lock bits, INTFLAG.DFLLCKC and INTFLAG.DFLLCKF are both set before enabling the DFLOOB interrupt.

**Bit 8 – DFLLRDY** DFLL Ready Interrupt Enable

0: The DFLL Ready interrupt is disabled.

1: The DFLL Ready interrupt is enabled, and an interrupt request will be generated when the DFLL Ready Interrupt flag is set.

Writing a zero to this bit has no effect.

Writing a '1' to this bit will clear the DFLL Ready Interrupt Enable bit, which disables the DFLL Ready interrupt.

**Bits 2, 3 – XOSCFAIL** XOSC n Clock Failure Interrupt Enable

0: The XOSC n Clock Failure interrupt is disabled.

1: The XOSC0 Clock Failure interrupt is enabled, and an interrupt request will be generated when the XOSC0 Clock Failure Interrupt flag is set.

Writing a zero to this bit has no effect.

Writing a '1' to this bit will clear the XOSC n Clock Failure Interrupt Enable bit, which disables the XOSC n Clock Failure interrupt.

**Bits 0, 1 – XOSCRDY** XOSC n Ready Interrupt Enable

0: The XOSC n Ready interrupt is disabled.

1: The XOSC0 Ready interrupt is enabled, and an interrupt request will be generated when the XOSC n Ready Interrupt flag is set.

Writing a zero to this bit has no effect.

Writing a '1' to this bit will clear the XOSC n Ready Interrupt Enable bit, which disables the XOSC n Ready interrupt.



### 18.7.3 Interrupt Enable Set

**Name:** INTENSET  
**Offset:** 0x08  
**Reset:** 0x00000000  
**Property:** PAC Write-Protection

This register allows the user to enable an interrupt without doing a read-modify-write operation. Changes in this register will also be reflected in the Interrupt Enable Clear register (INTENCLR).

Bit	31	30	29	28	27	26	25	24
					DPLL1LDRTO	DPLL1LTO	DPLL1LCKF	DPLL1LCKR
Access					R/W	R/W	R/W	R/W
Reset					0	0	0	0
Bit	23	22	21	20	19	18	17	16
					DPLL0LDRTO	DPLL0LTO	DPLL0LCKF	DPLL0LCKR
Access					R/W	R/W	R/W	R/W
Reset					0	0	0	0
Bit	15	14	13	12	11	10	9	8
				DFLLRCS	DFLLLCKC	DFLLLCKF	DFLLOOB	DFLLRDY
Access				R/W	R/W	R/W	R/W	R/W
Reset				0	0	0	0	0
Bit	7	6	5	4	3	2	1	0
					XOSCFAIL1	XOSCFAIL0	XOSCRDY1	XOSCRDY0
Access					R/W	R/W	R/W	R/W
Reset					0	0	0	0

**Bit 27 – DPLL1LDRTO** DPLL1 Loop Divider Ratio Update Complete Interrupt Enable  
 0: The DPLL1 Loop Divider Ratio Update Complete interrupt is disabled.  
 1: The DPLL1 Loop Divider Ratio Update Complete interrupt is enabled, and an interrupt request will be generated when the DPLL1 Loop Divider Ratio Update Complete Interrupt flag is set.  
 Writing a zero to this bit has no effect.  
 Writing a '1' to this bit will set the DPLL1 Loop Divider Ratio Update Complete Interrupt Enable bit, which enables the DPLL1 Loop Divider Ratio Update Complete interrupt.

**Bit 26 – DPLL1LTO** DPLL1 Lock Timeout Interrupt Enable  
 0: The DPLL1 Lock Timeout interrupt is disabled.  
 1: The DPLL1 Lock Timeout interrupt is enabled, and an interrupt request will be generated when the DPLL1 Lock Timeout Interrupt flag is set.  
 Writing a zero to this bit has no effect.  
 Writing a '1' to this bit will set the DPLL1 Lock Timeout Interrupt Enable bit, which enables the DPLL1 Lock Timeout interrupt.

**Bit 25 – DPLL1LCKF** DPLL1 Lock Fall Interrupt Enable  
 0: The DPLL1 Lock Fall interrupt is disabled.  
 1: The DPLL1 Lock Fall interrupt is enabled, and an interrupt request will be generated when the DPLL1 Lock Fall Interrupt flag is set.  
 Writing a zero to this bit has no effect.  
 Writing a '1' to this bit will set the DPLL1 Lock Fall Interrupt Enable bit, which enables the DPLL1 Lock Fall interrupt.

**Bit 24 – DPLL1LCKR** DPLL1 Lock Rise Interrupt Enable

0: The DPLL1 Lock Rise interrupt is disabled.

1: The DPLL1 Lock Rise interrupt is enabled, and an interrupt request will be generated when the DPLL1 Lock Rise Interrupt flag is set.

Writing a zero to this bit has no effect.

Writing a '1' to this bit will set the DPLL1 Lock Rise Interrupt Enable bit, which enables the DPLL1 Lock Rise interrupt.

**Bit 19 – DPLL0LDRTO** DPLL0 Loop Divider Ratio Update Complete Interrupt Enable

0: The DPLL0 Loop Divider Ratio Update Complete interrupt is disabled.

1: The DPLL0 Loop Divider Ratio Update Complete interrupt is enabled, and an interrupt request will be generated when the DPLL0 Loop Divider Ratio Update Complete Interrupt flag is set.

Writing a zero to this bit has no effect.

Writing a '1' to this bit will set the DPLL0 Loop Divider Ratio Update Complete Interrupt Enable bit, which enables the DPLL0 Loop Divider Ratio Update Complete interrupt.

**Bit 18 – DPLL0LTO** DPLL0 Lock Timeout Interrupt Enable

0: The DPLL0 Lock Timeout interrupt is disabled.

1: The DPLL0 Lock Timeout interrupt is enabled, and an interrupt request will be generated when the DPLL0 Lock Timeout Interrupt flag is set.

Writing a zero to this bit has no effect.

Writing a '1' to this bit will set the DPLL0 Lock Timeout Interrupt Enable bit, which enables the DPLL0 Lock Timeout interrupt.

**Bit 17 – DPLL0LCKF** DPLL0 Lock Fall Interrupt Enable

0: The DPLL0 Lock Fall interrupt is disabled.

1: The DPLL0 Lock Fall interrupt is enabled, and an interrupt request will be generated when the DPLL0 Lock Fall Interrupt flag is set.

Writing a zero to this bit has no effect.

Writing a '1' to this bit will set the DPLL0 Lock Fall Interrupt Enable bit, which enables the DPLL0 Lock Fall interrupt.

**Bit 16 – DPLL0LCKR** DPLL0 Lock Rise Interrupt Enable

0: The DPLL0 Lock Rise interrupt is disabled.

1: The DPLL0 Lock Rise interrupt is enabled, and an interrupt request will be generated when the DPLL0 Lock Rise Interrupt flag is set.

Writing a zero to this bit has no effect.

Writing a '1' to this bit will set the DPLL0 Lock Rise Interrupt Enable bit, which enables the DPLL0 Lock Rise interrupt.

**Bit 12 – DFLLRCS** DFLL Reference Clock Stopped Interrupt Enable

0: The DFLL Reference Clock Stopped interrupt is disabled.

1: The DFLL Reference Clock Stopped interrupt is enabled, and an interrupt request will be generated when the DFLL Reference Clock Stopped Interrupt flag is set.

Writing a zero to this bit has no effect.

Writing a '1' to this bit will set the DFLL Reference Clock Stopped Interrupt Enable bit, which enables the DFLL Reference Clock Stopped interrupt.

**Bit 11 – DFLLLCKC** DFLL Lock Coarse Interrupt Enable

0: The DFLL Lock Coarse interrupt is disabled.

1: The DFLL Lock Coarse interrupt is enabled, and an interrupt request will be generated when the DFLL Lock Coarse Interrupt flag is set.

Writing a zero to this bit has no effect.

Writing a '1' to this bit will set the DFLL Lock Coarse Interrupt Enable bit, which enables the DFLL Lock Coarse interrupt.

**Bit 10 – DFLLCKF** DFLL Lock Fine Interrupt Enable

0: The DFLL Lock Fine interrupt is disabled.

1: The DFLL Lock Fine interrupt is enabled, and an interrupt request will be generated when the DFLL Lock Fine Interrupt flag is set.

Writing a zero to this bit has no effect.

Writing a '1' to this bit will set the DFLL Lock Fine Interrupt Disable/Enable bit, disable the DFLL Lock Fine interrupt and set the corresponding interrupt request.

**Bit 9 – DFLOOB** DFLL Out Of Bounds Interrupt Enable

0: The DFLL Out Of Bounds interrupt is disabled.

1: The DFLL Out Of Bounds interrupt is enabled, and an interrupt request will be generated when the DFLL Out Of Bounds Interrupt flag is set.

Writing a zero to this bit has no effect.

Writing a '1' to this bit will set the DFLL Out Of Bounds Interrupt Enable bit, which enables the DFLL Out Of Bounds interrupt.

**Note:** Check that lock bits, INTFLAG.DFLLCKC and INTFLAG.DFLLCKF are both set before enabling the DFLOOB interrupt.

**Bit 8 – DFLLRDY** DFLL Ready Interrupt Enable

0: The DFLL Ready interrupt is disabled.

1: The DFLL Ready interrupt is enabled, and an interrupt request will be generated when the DFLL Ready Interrupt flag is set.

Writing a zero to this bit has no effect.

Writing a '1' to this bit will set the DFLL Ready Interrupt Enable bit, which enables the DFLL Ready interrupt.

**Bits 2, 3 – XOSCFAIL** XOSCn Clock Failure Interrupt Enable

0: The XOSCn Clock Failure interrupt is disabled.

1: The XOSCn Clock Failure interrupt is enabled, and an interrupt request will be generated when the XOSCn Clock Failure Interrupt flag is set.

Writing a zero to this bit has no effect.

Writing a '1' to this bit will set the XOSCn Clock Failure Interrupt Enable bit, which enables the XOSCn Clock Failure interrupt.

**Bits 0, 1 – XOSCRDY** XOSCn Ready Interrupt Enable

0: The XOSCn Ready interrupt is disabled.

1: The XOSCn Ready interrupt is enabled, and an interrupt request will be generated when the XOSC0 Ready Interrupt flag is set.

Writing a zero to this bit has no effect.

Writing a '1' to this bit will set the XOSCn Ready Interrupt Enable bit, which enables the XOSCn Ready interrupt.

## 18.7.4 Interrupt Flag Status and Clear

**Name:** INTFLAG  
**Offset:** 0x0C  
**Reset:** 0x00000000

Bit	31	30	29	28	27	26	25	24
					DPLL1LDRTO	DPLL1LTO	DPLL1LCKF	DPLL1LCKR
Access					R/W	R/W	R/W	R/W
Reset					0	0	0	0
Bit	23	22	21	20	19	18	17	16
					DPLL0LDRTO	DPLL0LTO	DPLL0LCKF	DPLL0LCKR
Access					R/W	R/W	R/W	R/W
Reset					0	0	0	0
Bit	15	14	13	12	11	10	9	8
				DFLLRCS	DFLLLCKC	DFLLLCKF	DFLLOOB	DFLLRDY
Access				R/W	R/W	R/W	R/W	R/W
Reset				0	0	0	0	0
Bit	7	6	5	4	3	2	1	0
					XOSCFAIL1	XOSCFAIL0	XOSCRDY1	XOSCRDY0
Access					R/W	R/W	R/W	R/W
Reset					0	0	0	0

### Bit 27 – DPLL1LDRTO DPLL1 Loop Divider Ratio Update Complete

This flag is cleared by writing a '1' to it.

This flag is set when the DPLL1 Loop Divider Ratio Update is Completed and will generate an interrupt request if INTENSET.DPLL1LDRTO is '1'.

Writing a zero to this bit has no effect.

Writing a '1' to this bit clears the DPLL1 Loop Divider Ratio Update Complete interrupt flag.

### Bit 26 – DPLL1LTO DPLL1 Lock Timeout

This flag is cleared by writing a '1' to it.

This flag is set on a zero-to-one transition of the DPLL1 Lock Timeout bit in the Status register (STATUS.DPLL1LTO) and will generate an interrupt request if INTENSET.DPLL1LTO is '1'.

Writing a zero to this bit has no effect.

Writing a '1' to this bit clears the DPLL1 Lock Timeout interrupt flag.

### Bit 25 – DPLL1LCKF DPLL1 Lock Fall

This flag is cleared by writing a '1' to it.

This flag is set on a zero-to-one transition of the DPLL1 Lock Fall bit in the Status register (STATUS.DPLL1LCKF) and will generate an interrupt request if INTENSET.DPLL1LCKF is '1'.

Writing a zero to this bit has no effect.

Writing a '1' to this bit clears the DPLL1 Lock Fall interrupt flag.

### Bit 24 – DPLL1LCKR DPLL1 Lock Rise

This flag is cleared by writing a '1' to it.

This flag is set on a zero-to-one transition of the DPLL1 Lock Rise bit in the Status register (STATUS.DPLL1LCKR) and will generate an interrupt request if INTENSET.DPLL1LCKR is '1'.

Writing a zero to this bit has no effect.

Writing a '1' to this bit clears the DPLL1 Lock Rise interrupt flag.

**Bit 19 – DPLL0LDRTO** DPLL0 Loop Divider Ratio Update Complete

This flag is cleared by writing a '1' to it.

This flag is set when the DPLL0 Loop Divider Ratio Update is Completed and will generate an interrupt request if INTENSET.DPLL0LDRTO is '1'.

Writing a zero to this bit has no effect.

Writing a '1' to this bit clears the DPLL0 Loop Divider Ratio Update Complete interrupt flag.

**Bit 18 – DPLL0LTO** DPLL0 Lock Timeout

This flag is cleared by writing a '1' to it.

This flag is set on a zero-to-one transition of the DPLL0 Lock Timeout bit in the Status register (STATUS.DPLL0LTO) and will generate an interrupt request if INTENSET.DPLL0LTO is '1'.

Writing a zero to this bit has no effect.

Writing a '1' to this bit clears the DPLL0 Lock Timeout interrupt flag.

**Bit 17 – DPLL0LCKF** DPLL0 Lock Fall

This flag is cleared by writing a '1' to it.

This flag is set on a zero-to-one transition of the DPLL0 Lock Fall bit in the Status register (STATUS.DPLL0LCKF) and will generate an interrupt request if INTENSET.DPLL0LCKF is '1'.

Writing a zero to this bit has no effect.

Writing a '1' to this bit clears the DPLL0 Lock Fall interrupt flag.

**Bit 16 – DPLL0LCKR** DPLL0 Lock Rise

This flag is cleared by writing a '1' to it.

This flag is set on a zero-to-one transition of the DPLL0 Lock Rise bit in the Status register (STATUS.DPLL0LCKR) and will generate an interrupt request if INTENSET.DPLL0LCKR is '1'.

Writing a zero to this bit has no effect.

Writing a '1' to this bit clears the DPLL0 Lock Rise interrupt flag.

**Bit 12 – DFLLRCS** DFLL Reference Clock Stopped

This flag is cleared by writing a '1' to it.

This flag is set on a zero-to-one transition of the DFLL Reference Clock Stopped bit in the Status register (STATUS.DFLLRCS) and will generate an interrupt request if INTENSET.DFLLRCS is '1'.

Writing a zero to this bit has no effect.

Writing a '1' to this bit clears the DFLL Reference Clock Stopped interrupt flag.

**Bit 11 – DFLLLCKC** DFLL Lock Coarse

This flag is cleared by writing a '1' to it.

This flag is set on a zero-to-one transition of the DFLL Lock Coarse bit in the Status register (STATUS.DFLLLCKC) and will generate an interrupt request if INTENSET.DFLLLCKC is '1'.

Writing a zero to this bit has no effect.

Writing a '1' to this bit clears the DFLL Lock Coarse interrupt flag.

**Bit 10 – DFLLLCKF** DFLL Lock Fine

This flag is cleared by writing a '1' to it.

This flag is set on a zero-to-one transition of the DFLL Lock Fine bit in the Status register (STATUS.DFLLLCKF) and will generate an interrupt request if INTENSET.DFLLLCKF is '1'.

Writing a zero to this bit has no effect.

Writing a '1' to this bit clears the DFLL Lock Fine interrupt flag.

**Bit 9 – DFLL0OB** DFLL Out Of Bounds

This flag is cleared by writing a '1' to it.

This flag is set on a zero-to-one transition of the DFLL Out Of Bounds bit in the Status register (STATUS.DFLL0OB) and will generate an interrupt request if INTENSET.DFLL0OB is '1'.

Writing a zero to this bit has no effect.

Writing a '1' to this bit clears the DFLL Out Of Bounds interrupt flag.

**Bit 8 – DFLLRDY** DFLL Ready

This flag is cleared by writing a '1' to it.

This flag is set on a zero-to-one transition of the DFLL Ready bit in the Status register (STATUS.DFLLRDY) and will generate an interrupt request if INTENSET.DFLLRDY is '1'.

Writing a zero to this bit has no effect.

Writing a '1' to this bit clears the DFLL Ready interrupt flag.

**Bits 2, 3 – XOSCFAIL** XOSCn Clock Failure

This flag is cleared by writing a '1' to it.

This flag is set on a zero-to-one transition of the XOSCn Clock Failure bit in the Status register (STATUS.XOSCFAILn) and will generate an interrupt request if INTENSET.XOSCFAILn is '1'.

Writing a zero to this bit has no effect.

Writing a '1' to this bit clears the XOSCn Clock Failure interrupt flag.

**Bits 0, 1 – XOSCRDY** XOSCn Ready

This flag is cleared by writing a '1' to it.

This flag is set on a zero-to-one transition of the XOSC0 Ready bit in the Status register (STATUS.XOSCRDYn) and will generate an interrupt request if INTENSET.XOSCRDYn is '1'.

Writing a zero to this bit has no effect.

Writing a '1' to this bit clears the XOSCn Ready interrupt flag.

## 18.7.5 Status

**Name:** STATUS  
**Offset:** 0x10  
**Reset:** 0x00000000

Bit	31	30	29	28	27	26	25	24
						DPLL1TO	DPLL1LCKF	DPLL1LCKR
Access						R	R	R
Reset						0	0	0
Bit	23	22	21	20	19	18	17	16
						DPLL0TO	DPLL0LCKF	DPLL0LCKR
Access						R	R	R
Reset						0	0	0
Bit	15	14	13	12	11	10	9	8
				DFLLRCS	DFLLLCKC	DFLLLCKF	DFLLOOB	DFLLRDY
Access				R	R	R	R	R
Reset				0	0	0	0	0
Bit	7	6	5	4	3	2	1	0
			XOSCCKSW1	XOSCCKSW0	XOSCFAIL1	XOSCFAIL0	XOSCRDY1	XOSCRDY0
Access			R	R	R	R	R	R/W
Reset			0	0	0	0	0	0

**Bit 26 – DPLL1TO** DPLL1 Lock Timeout  
0: DPLL1 Lock time-out not detected.  
1: DPLL1 Lock time-out detected.

**Bit 25 – DPLL1LCKF** DPLL1 Lock Fall  
0: DPLL1 Lock fall edge not detected.  
1: DPLL1 Lock fall edge detected.

**Bit 24 – DPLL1LCKR** DPLL1 Lock Rise  
0: DPLL1 Lock rise edge not detected.  
1: DPLL1 Lock rise edge detected.

**Bit 18 – DPLL0TO** DPLL0 Lock Timeout  
0: DPLL0 Lock time-out not detected.  
1: DPLL0 Lock time-out detected.

**Bit 17 – DPLL0LCKF** DPLL0 Lock Fall  
0: DPLL0 Lock fall edge not detected.  
1: DPLL0 Lock fall edge detected.

**Bit 16 – DPLL0LCKR** DPLL0 Lock Rise  
0: DPLL0 Lock rise edge not detected.  
1: DPLL0 Lock rise edge detected.

**Bit 12 – DFLLRCS** DFLL Reference Clock Stopped  
0: DFLL reference clock is running.  
1: DFLL reference clock has stopped.

**Bit 11 – DFLLCKC** DFLL Lock Coarse  
0: No DFLL coarse lock detected.  
1: DFLL coarse lock detected.

**Bit 10 – DFLLCKF** DFLL Lock Fine  
0: No DFLL fine lock detected.  
1: DFLL fine lock detected.

**Bit 9 – DFLLCOB** DFLL Out Of Bounds  
0: No DFLL Out Of Bounds detected.  
1: DFLL Out Of Bounds detected.

**Bit 8 – DFLLRDY** DFLL Ready  
0: DFLL is not ready.  
1: DFLL is stable and ready to be used as a clock source.

**Bit 5 – XOSCCKSW1** XOSC1 Clock Switch  
0: XOSC1 is not switched and provides the external clock or crystal oscillator clock.  
1: XOSC is switched and provides the safe clock.

**Bit 4 – XOSCCKSW0** XOSC0 Clock Switch  
0: XOSC0 is not switched and provides the external clock or crystal oscillator clock.  
1: XOSC0 is switched and provides the safe clock.

**Bit 3 – XOSCFAIL1** XOSC1 Clock Failure  
0: XOSC1 failure not detected.  
1: XOSC1 failure detected.

**Bit 2 – XOSCFAIL0** XOSC0 Clock Failure  
0: XOSC0 failure not detected.  
1: XOSC0 failure detected.

**Bit 1 – XOSCRDY1** XOSC1 Ready  
0: XOSC1 is not ready.  
1: XOSC1 is stable and ready to be used as a clock source.

**Bit 0 – XOSCRDY0** XOSC0 Ready  
0: XOSC0 is not ready.  
1: XOSC0 is stable and ready to be used as a clock source.



### 18.7.6 External Multipurpose Crystal Oscillator Control

**Name:** XOSCCTRL  
**Offset:** 0x14 + n\*0x04 [n=0..1]  
**Reset:** 0x00000080  
**Property:** PAC Write-Protection

Bit	31	30	29	28	27	26	25	24
	CFDPRESC[3:0]							
Access					R/W	R/W	R/W	R/W
Reset					0	0	0	0
Bit	23	22	21	20	19	18	17	16
	STARTUP[3:0]						SWBEN	CFDEN
Access	R/W	R/W	R/W	R/W			R/W	R/W
Reset	0	0	0	0			0	0
Bit	15	14	13	12	11	10	9	8
	ENALC	IMULT[3:0]				IPTAT[1:0]		LOWBUFGAI N
Access	R/W	R/W	R/W	R/W	R/W	R/W	R/W	R/W
Reset	0	0	0	0	0	0	0	0
Bit	7	6	5	4	3	2	1	0
	ONDEMAND	RUNSTDBY				XTALEN	ENABLE	
Access	R/W	R/W				R/W	R/W	
Reset	1	0				0	0	

#### Bits 27:24 – CFDPRESC[3:0] Clock Failure Detector Prescaler

These bits select the prescaler for the clock failure detector.  
 The DFLL48 oscillator is used to clock the CFD prescaler.  
 The CFD safe clock frequency is the DFLL48 frequency divided by  $2^{CFDPRESC}$ .

#### Bits 23:20 – STARTUP[3:0] Start-Up Time

These bits select start-up time for the oscillator XOSCn according to the table below.  
 The OSCULP32K oscillator is used to clock the start-up counter.

**Table 18-6.** Start-UpTime for External Multipurpose Crystal Oscillator

STARTUP[3:0]	Number of OSCULP32K Clock Cycles	Number of XOSC Clock Cycles	Approximate Equivalent Time(
0x0	1	3	31µs
0x1	2	3	61µs
0x2	4	3	122µs
0x3	8	3	244µs
0x4	16	3	488µs
0x5	32	3	977µs
0x6	64	3	1953µs
0x7	128	3	3906µs
0x8	256	3	7813µs
0x9	512	3	15625µs
0xA	1024	3	31250µs
0xB	2048	3	62500µs
0xC	4096	3	125000µs

.....continued

STARTUP[3:0]	Number of OSCULP32K Clock Cycles	Number of XOSC Clock Cycles	Approximate Equivalent Time(
0xD	8192	3	250000µs
0xE	16384	3	500000µs
0xF	32768	3	1000000µs

**Bit 17 – SWBEN** Xosc Clock Switch Enable

This bit controls the XOSCn output clock switch back to the external clock or crystal oscillator in case of clock recovery :

0: The clock switch back is disabled.

1: The clock switch back is enabled. This bit is reset once the XOSCn output clock is switched back to the external clock or crystal oscillator.

**Bit 16 – CFDEN** Clock Failure Detector Enable

This bit controls the XOSCn clock failure detector :

0: the Clock Failure Detector is disabled.

1: the Clock Failure Detector is enabled.

**Bit 15 – ENALC** Automatic Loop Control Enable

This bit controls the XOSCn automatic loop control :

0: the automatic loop control is disabled.

1: the automatic loop control is enabled. Oscillator's amplitude will be automatically adjusted during Crystal Oscillator operation.

**Bits 14:11 – IMULT[3:0]** Oscillator Current Multiplier

These bits select the current multiplier for the oscillator XOSCn, given in table [External Multipurpose Crystal Oscillator Current Settings](#).

**Bits 10:9 – IPTAT[1:0]** Oscillator Current Reference

These bits select the current reference for the oscillator XOSCn, given in table below.

**Table 18-7.** External Multipurpose Crystal Oscillator Current Settings

Frequency Range	Current Setting	
	IMULT[3:0]	IPTAT[1:0]
>24MHz to 48MHz	6	3
>16MHz to 24MHz	5	3
>8MHz to 16MHz	4	3
8MHz	3	2

For relatively small CLOAD in a frequency range, the setting for the lower frequency range can be used to preserve current consumption.

**Bit 8 – LOWBUFGAIN** Low Buffer Gain Enable

0: The low buffer gain of oscillator XOSCn is disabled.

1: The low buffer gain of oscillator XOSCn is enabled.

When XOSCCTRLn.ENALC=0 this bit has no effect.

When XOSCCTRLn.ENALC=1, this bit is used to adjust the oscillator's amplitude in automatic loop control.

The default value of LOWBUFGAIN=0 should be used to allow operating with a low amplitude oscillator. Use this setting except to solve stability issues.

Setting LOWBUFGAIN=1 will increase the oscillator's amplitude by a factor of approximately 2. Use this setting to solve stability issues.

**Bit 7 – ONDEMAND** On Demand Control

The On Demand operation mode allows the oscillator XOSCn to be enabled or disabled, depending on peripheral clock requests.

If On Demand is set, the oscillator will be running only when requested by a peripheral and enabled (XOSCCTRLn. ENABLE=1). If there is no peripheral requesting the oscillator's clock source, the oscillator will be in a disabled state.

If On Demand is cleared, the oscillator will always be running when enabled (XOSCCTRLn.ENABLE=1). In standby sleep mode, the On Demand operation is still active.

0: The oscillator is always on.

1: The oscillator is running when a peripheral is requesting the oscillator to be used as a clock source. The oscillator is not running if no peripheral is requesting the clock source.

**Bit 6 – RUNSTDBY** Run in Standby

This bit controls how the XOSCn behaves during standby sleep mode:

0: The XOSCn is not running in standby sleep mode if no peripheral requests the clock.

1: The XOSCn is running in standby sleep mode. If ONDEMAND is one, the XOSCn will be running when a peripheral is requesting the clock. If ONDEMAND is zero, the clock source will always be running in standby sleep mode.

**Bit 2 – XTALEN** Crystal Oscillator Enable

This bit controls the connections between the I/O pads and the external clock or crystal oscillator XOSCn:

0: External clock connected on XIN. XOUT can be used as general-purpose I/O.

1: Crystal connected to XIN/XOUT.

**Bit 1 – ENABLE** Oscillator Enable

0: The oscillator XOSCn is disabled.

1: The oscillator XOSCn is enabled.

### 18.7.7 DFLL48M Control A

**Name:** DFLLCTRLA  
**Offset:** 0x1C  
**Reset:** 0x82  
**Property:** PAC Write-Protection

Bit	7	6	5	4	3	2	1	0
	ONDEMAND	RUNSTDBY					ENABLE	
Access	R/W	R/W					R/W	
Reset	1	0					1	

#### Bit 7 – ONDEMAND On Demand Control

The On Demand operation mode allows the DFLL to be enabled or disabled depending on peripheral clock requests.

If On Demand is set, the DFLL will only be running when requested by a peripheral and enabled (DFLLTRLA.ENABLE=1). If there is no peripheral requesting the DFLL's clock source, the DFLL will be in a disabled state.

If On Demand is disabled the DFLL will always be running when enabled (DFLLTRLA.ENABLE=1). In standby sleep mode, the On Demand operation is still active.

0: The DFLL is always on.

1: The DFLL is running when a peripheral is requesting the DFLL to be used as a clock source. The DFLL is not running if no peripheral is requesting the clock source.

#### Bit 6 – RUNSTDBY Run in Standby

This bit controls how the DFLL behaves during standby sleep mode:

0: The DFLL is not running in standby sleep mode if no peripheral requests the clock.

1: The DFLL is running in standby sleep mode. If ONDEMAND is one, the DFLL will be running when a peripheral is requesting the clock. If ONDEMAND is zero, the clock source will always be running in standby sleep mode.

#### Bit 1 – ENABLE DFLL Enable

0: The DFLL oscillator is disabled.

1: The DFLL oscillator is enabled.

**Note:** This bit is write-synchronized: Due to synchronization, there is delay from updating the register until the peripheral is enabled/disabled. The value written to DFLLCTRLA.ENABLE will read back immediately after written.

### 18.7.8 DFLL48M Control B

**Name:** DFLLCTRLB  
**Offset:** 0x20  
**Reset:** 0x00  
**Property:** Read-Synchronized

**Note:** This register is read-synchronized: DFLLSYNC.DFLLCTRLB must be checked to ensure the DFLLCTRLB register synchronization is complete.

Bit	7	6	5	4	3	2	1	0
	WAITLOCK	BPLCKC	QLDIS	CCDIS	USBCRM	LLAW	STABLE	MODE
Access	R/W	R/W	R/W	R/W	R/W	R/W	R/W	R/W
Reset	0	0	0	0	0	0	0	0

#### Bit 7 – WAITLOCK Wait Lock

This bit controls the DFLL output clock, depending on lock status:  
0: Output clock before the DFLL is locked.  
1: Output clock when DFLL is locked (Fine lock).

#### Bit 6 – BPLCKC Bypass Coarse Lock

This bit controls the coarse lock procedure:  
0: Bypass coarse lock is disabled.  
1: Bypass coarse lock is enabled.

#### Bit 5 – QLDIS Quick Lock Disable

0: Quick Lock is enabled.  
1: Quick Lock is disabled.

#### Bit 4 – CCDIS Chill Cycle Disable

0: Chill Cycle is enabled.  
1: Chill Cycle is disabled.

#### Bit 3 – USBCRM USB Clock Recovery Mode

0: USB Clock Recovery Mode is disabled.  
1: USB Clock Recovery Mode is enabled.

#### Bit 2 – LLAW Lose Lock After Wake

0: Locks will not be lost after waking up from sleep modes if the DFLL clock has been stopped.  
1: Locks will be lost after waking up from sleep modes if the DFLL clock has been stopped.

#### Bit 1 – STABLE Stable DFLL Frequency

0: FINE calibration tracks changes in output frequency.  
1: FINE calibration register value will be fixed after a fine lock.

#### Bit 0 – MODE Operating Mode Selection

0: The DFLL operates in open-loop operation.  
1: The DFLL operates in closed-loop operation.

### 18.7.9 DFLL48M Value

**Name:** DFLLVAL  
**Offset:** 0x24  
**Reset:** 0x0000XXXX  
**Property:** PAC Write-Protection, Read-Synchronized, Write-Synchronized

**Note:** This register is read- and write-synchronized: DFLLSYNC.DFLLVAL must be checked to ensure the DFLLVAL register synchronization is complete.

Bit	31	30	29	28	27	26	25	24	
	DIFF[15:8]								
Access	R	R	R	R	R	R	R	R	
Reset	0	0	0	0	0	0	0	0	
Bit	23	22	21	20	19	18	17	16	
	DIFF[7:0]								
Access	R	R	R	R	R	R	R	R	
Reset	0	0	0	0	0	0	0	x	
Bit	15	14	13	12	11	10	9	8	
	COARSE[5:0]								
Access	R/W	R/W	R/W	R/W	R/W	R/W			
Reset	0	0	0	0	0	x			
Bit	7	6	5	4	3	2	1	0	
	FINE[7:0]								
Access	R/W	R/W	R/W	R/W	R/W	R/W	R/W	R/W	
Reset	0	0	0	0	0	0	0	x	

#### Bits 31:16 – DIFF[15:0] Multiplication Ratio Difference

In closed-loop mode (DFLLCTRLB.MODE is written to one), this bit group indicates the difference between the ideal number of DFLL cycles and the counted number of cycles. This value is not updated in open-loop mode, and should be considered invalid in that case.

#### Bits 15:10 – COARSE[5:0] Coarse Value

Set the value of the Coarse Calibration register. In closed-loop mode, this field is read-only. The DFLL48M is factory-calibrated for 48MHz. Register DFLLVAL.COARSE stores the coarse frequency calibration after reset.

#### Bits 7:0 – FINE[7:0] Fine Value

Set the value of the Fine Calibration register. In closed-loop mode, this field is read-only. The DFLL48M is factory-calibrated for 48MHz. Register DFLLVAL.FINE stores the coarse frequency calibration after reset.

### 18.7.10 DFLL48M Multiplier

**Name:** DFLLMUL  
**Offset:** 0x28  
**Reset:** 0x00000000  
**Property:** PAC Write-Protection, Write-Synchronized

**Note:** This register is write-synchronized: DFLLSYNC.DFLLMUL must be checked to ensure the DFLLMUL register synchronization is complete.

Bit	31	30	29	28	27	26	25	24
	CSTEP[5:0]							
Access	R/W	R/W	R/W	R/W	R/W	R/W		
Reset	0	0	0	0	0	0		
Bit	23	22	21	20	19	18	17	16
	FSTEP[7:0]							
Access	R/W	R/W	R/W	R/W	R/W	R/W	R/W	R/W
Reset	0	0	0	0	0	0	0	0
Bit	15	14	13	12	11	10	9	8
	MUL[15:8]							
Access	R/W	R/W	R/W	R/W	R/W	R/W	R/W	R/W
Reset	0	0	0	0	0	0	0	0
Bit	7	6	5	4	3	2	1	0
	MUL[7:0]							
Access	R/W	R/W	R/W	R/W	R/W	R/W	R/W	R/W
Reset	0	0	0	0	0	0	0	0

#### Bits 31:26 – CSTEP[5:0] Coarse Maximum Step

This bit group indicates the maximum step size allowed during coarse adjustment in closed-loop mode. When adjusting to a new frequency, the expected output frequency overshoot depends on this step size.

#### Bits 23:16 – FSTEP[7:0] Fine Maximum Step

This bit group indicates the maximum step size allowed during fine adjustment in closed-loop mode. When adjusting to a new frequency, the expected output frequency overshoot depends on this step size.

#### Bits 15:0 – MUL[15:0] DFLL Multiply Factor

This field determines the ratio of the CLK\_DFLL output frequency to the CLK\_DFLL\_REF input frequency. Writing to the MUL bits will cause locks to be lost and the fine calibration value to be reset to its midpoint.

### 18.7.11 DFLL48M Synchronization

**Name:** DFLLSYNC  
**Offset:** 0x2C  
**Reset:** 0x00

Bit	7	6	5	4	3	2	1	0
				DFLLMUL	DFLLVAL	DFLLCTRLB	ENABLE	
Access				R	R	R	R	
Reset				0	0	0	0	

#### Bit 4 – DFLLMUL DFLLMUL Synchronization Busy

This bit is cleared when the synchronization of DFLLMUL register between the clock domains is complete.

This bit is set when the synchronization of DFLLMUL register between clock domains is started. The DFLLMUL synchronization only applies for write operations.

#### Bit 3 – DFLLVAL DFLLVAL Synchronization Busy

This bit is cleared when the synchronization of DFLLVAL register between the clock domains is complete.

This bit is set when the synchronization of DFLLVAL register between clock domains is started. The DFLLVAL synchronization applies for read and write operations.

#### Bit 2 – DFLLCTRLB DFLLCTRLB Synchronization Busy

This bit is cleared when the synchronization of DFLLCTRLB register between the clock domains is complete.

This bit is set when the synchronization of DFLLCTRLB register between clock domains is started. The DFLLCTRLB synchronization only applies for write operations.

#### Bit 1 – ENABLE ENABLE Synchronization Busy

This bit is cleared when the synchronization of ENABLE register bit between the clock domains is complete.

This bit is set when the synchronization of ENABLE register bit between clock domains is started.



## 18.7.12 DPLL Control A

**Name:** DPLLCTRLA  
**Offset:** 0x30 + n\*0x14 [n=0..1]  
**Reset:** 0x80  
**Property:** PAC Write-Protection, Write-Synchronized Bits, Enable-Protected Bits

Bit	7	6	5	4	3	2	1	0
	ONDEMAND	RUNSTDBY					ENABLE	
Access	R/W	R/W					R/W	
Reset	1	0					0	

### Bit 7 – ONDEMAND On Demand Control

The On Demand operation mode allows the DPLLn to be enabled or disabled, depending on peripheral clock requests.

If On Demand is set, the DPLLn will be running only when requested by a peripheral and enabled (DPLLnCTRLA.ENABLE=1). If there is no peripheral requesting the DPLLn's clock source, the DPLLn will be in a disabled state.

If On Demand is cleared, the DPLLn will always be running when enabled (DPLLnCTRLA.ENABLE=1). In standby sleep mode, the On Demand operation is still active.

0: The DPLLn is always running.

1: The DPLLn is running when a peripheral is requesting the DPLLn to be used as a clock source. The DPLLn is not running if no peripheral is requesting the clock source.

### Bit 6 – RUNSTDBY Run in Standby

This bit controls how the DPLLn behaves during standby sleep mode:

0: The DPLLn is not running in standby sleep mode if no peripheral requests the clock.

1: The DPLLn is running in standby sleep mode. If ONDEMAND is one, the DPLLn will be running when a peripheral is requesting the clock. If ONDEMAND is zero, the clock source will always be running in standby sleep mode.

### Bit 1 – ENABLE DPLL Enable

0: The DPLLn is disabled.

1: The DPLLn is enabled.

The software operation of enabling or disabling the DPLLn takes a few clock cycles, so the DPLLnSYNDBUSY.ENABLE status bit indicates when the DPLLn is successfully enabled or disabled.

### 18.7.13 DPLL Ratio Control

**Name:** DPLL<sub>n</sub>RATIO  
**Offset:** 0x34 + n\*0x14 [n=0..1]  
**Reset:** 0x00000000  
**Property:** PAC Write-Protection, Write-Synchronized

Refer to the Synchronization section in the Clock System Overview chapter for details on the functionality of this register.

**Note:** This register is write-synchronized: DPLL<sub>n</sub>SYN<sub>n</sub>BUSY.DPLL<sub>n</sub>RATIO must be checked to ensure the DPLL<sub>n</sub>RATIO register synchronization is complete.

Bit	31	30	29	28	27	26	25	24	
Access									
Reset									
Bit	23	22	21	20	19	18	17	16	
Access				LDRFRAC[4:0]					
Reset				R/W	R/W	R/W	R/W	R/W	
Reset				0	0	0	0	0	
Bit	15	14	13	12	11	10	9	8	
Access				LDR[12:8]					
Reset				R/W	R/W	R/W	R/W	R/W	
Reset				0	0	0	0	0	
Bit	7	6	5	4	3	2	1	0	
Access	LDR[7:0]								
Reset	R/W	R/W	R/W	R/W	R/W	R/W	R/W	R/W	
Reset	0	0	0	0	0	0	0	0	

#### Bits 20:16 – LDRFRAC[4:0] Loop Divider Ratio Fractional Part

Write these bits to set the fractional part of the frequency multiplier. Due to synchronization there is a delay between writing to DPLL<sub>n</sub>RATIO.LDRFRAC[4:0] and the effect on the DPLL<sub>n</sub> output clock. The value written DPLL<sub>n</sub>RATIO.LDRFRAC[4:0] will be read back immediately and the DPLL<sub>n</sub>RATIO bit in the synchronization busy register, DPLL<sub>n</sub>SYN<sub>n</sub>BUSY.DPLL<sub>n</sub>RATIO, will be set. DPLL<sub>n</sub>SYN<sub>n</sub>BUSY.DPLL<sub>n</sub>RATIO will be cleared when the operation is completed.

#### Bits 12:0 – LDR[12:0] Loop Divider Ratio

Write these bits to set the integer part of the frequency multiplier. The value written DPLL<sub>n</sub>RATIO.LDR[3:0] will be read back immediately and the DPLL<sub>n</sub>RATIO bit in the synchronization busy register, DPLL<sub>n</sub>SYN<sub>n</sub>BUSY.DPLL<sub>n</sub>RATIO, will be set. DPLL<sub>n</sub>SYN<sub>n</sub>BUSY.DPLL<sub>n</sub>RATIO will be cleared when the operation is completed.

### 18.7.14 DPLL Control B

**Name:** DPLLCTRLB  
**Offset:** 0x38 + n\*0x14 [n=0..1]  
**Reset:** 0x00000020  
**Property:** PAC Write-Protection, Enable-Protected

Bit	31	30	29	28	27	26	25	24
						DIV[10:8]		
Access						R/W	R/W	R/W
Reset						0	0	0
Bit	23	22	21	20	19	18	17	16
	DIV[7:0]							
Access	R/W	R/W	R/W	R/W	R/W	R/W	R/W	R/W
Reset	0	0	0	0	0	0	0	0
Bit	15	14	13	12	11	10	9	8
	DCOEN	DCOFILTER[2:0]			LBYPASS	LTIME[2:0]		
Access	R/W	R/W	R/W	R/W	R/W	R/W	R/W	R/W
Reset	0	0	0	0	0	0	0	0
Bit	7	6	5	4	3	2	1	0
	REFCLK[2:0]			WUF	FILTER[3:0]			
Access	R/W	R/W	R/W	R/W	R/W	R/W	R/W	R/W
Reset	0	0	1	0	0	0	0	0

#### Bits 26:16 – DIV[10:0] Clock Divider

These bits are used to set the XOSC clock division factor and can be calculated with following formula:

$$f_{DIV} = \frac{f_{XOSC}}{2 \times (DIV + 1)}$$

#### Bit 15 – DCOEN DCO Filter Enable

0: Disable DCO filter controller. Sigma-Delta DAC is automatically set the PLL itself.  
 1: Enable DCO filter controller. DCOFILTER[2:0] is used to select sigma-delta DAC filter bandwidth.

#### Bits 14:12 – DCOFILTER[2:0] Sigma-Delta DCO Filter Selection

These bits select the DPLLn sigma-delta DCO filter type, as shown in the table below:

**Table 18-8.** Sigma-delta DCO Filter selection

DCOFILTER[2:0]	Capacitor (pF)	Bandwidth Fn (MHz)
0x0	0.5	3.21
0x1	1	1.6
0x2	1.5	1.1
0x3	2	0.8
0x4	2.5	0.64
0x5	3	0.55
0x6	3.5	0.45
0x7	4	0.4

#### Bit 11 – LBYPASS Lock Bypass

### Bits 10:8 – LTIME[2:0] Lock Time

Write these bits to select the lock time-out value, as shown in the figure below:

Value	Name	Description
0x0	Default	No time-out. Automatic lock.
0x1	Reserved	
0x2	Reserved	
0x3	Reserved	
0x4	800US	Time-out if no lock within 800 us
0x5	900US	Time-out if no lock within 900 us
0x6	1MS	Time-out if no lock within 1 ms
0x7	1P1MS	Time-out if no lock within 1.1 ms

### Bits 7:5 – REFCLK[2:0] Reference Clock Selection

Write these bits to select the DPLLn clock reference, as shown in the table below:

Value	Name	Description
0x0	GCLK	Dedicated GCLK clock reference
0x1	XOSC32	XOSC32K clock reference (default)
0x2	XOSC0	XOSC0 clock reference
0x3	XOSC1	XOSC1 clock reference
Other	-	Reserved

### Bit 4 – WUF Wake Up Fast

0: DPLLn clock is output after startup and lock time.

1: DPLLn clock is output after startup time.

### Bits 3:0 – FILTER[3:0] Proportional Integral Filter Selection

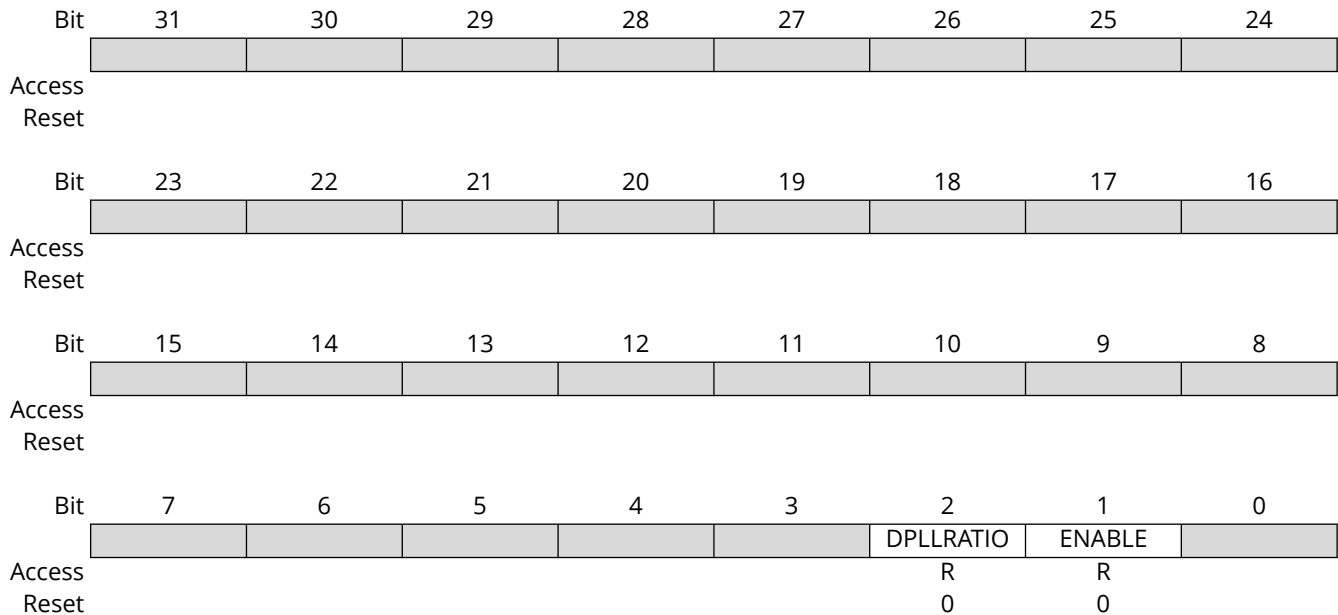
These bits select the DPLLn digital filter type, as shown in the table below:

**Table 18-9.** Proportional Integral Filter selection

FILTER[3:0]	PLL Bandwidth (fn)	Damping Factor
0x0	92.7 kHz	0.76
0x1	131 kHz	1.08
0x2	46.4 kHz	0.38
0x3	65.6 kHz	0.54
0x4	131 kHz	0.56
0x5	185 kHz	0.79
0x6	65.6 kHz	0.28
0x7	92.7 kHz	0.39
0x8	46.4 kHz	1.49
0x9	65.6 kHz	2.11
0xA	23.2 kHz	0.75
0xB	32.8 kHz	1.06
0xC	65.6 kHz	1.07
0xD	92.7 kHz	1.51
0xE	32.8 kHz	0.53
0xF	46.4 kHz	0.75

### 18.7.15 DPLL Synchronization Busy

**Name:** DPLLSYNCBUSY  
**Offset:** 0x3C + n\*0x14 [n=0..1]  
**Reset:** 0x00000000



**Bit 2 - DPLLRRATIO** DPLL Loop Divider Ratio Synchronization Status

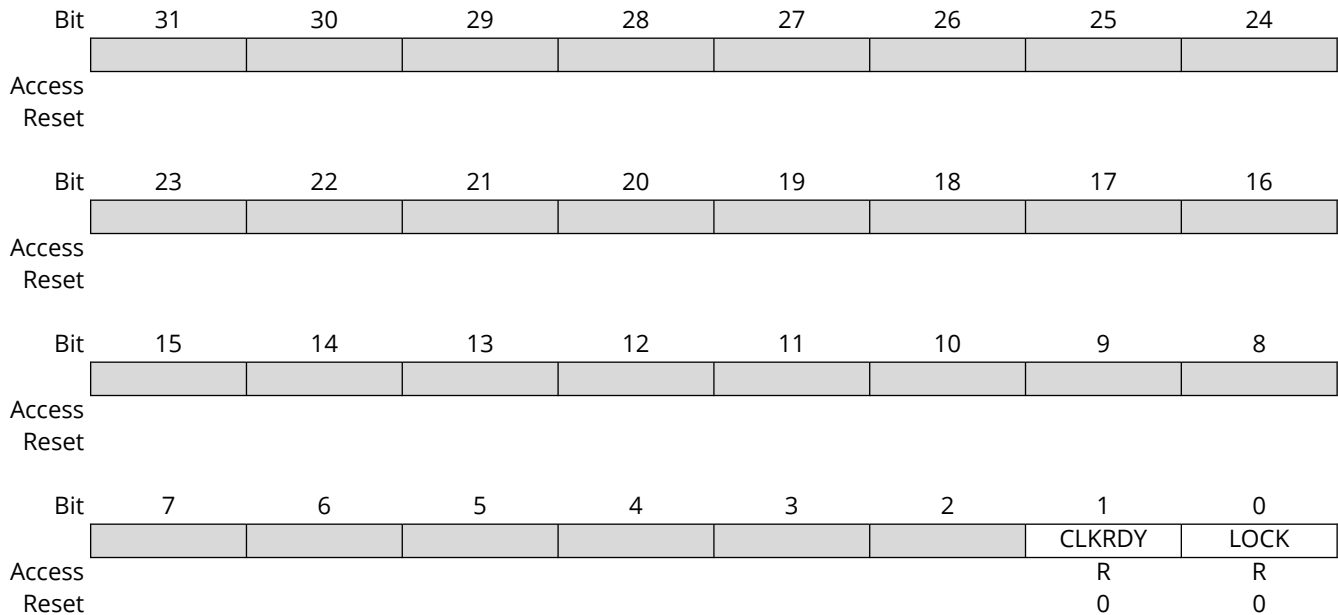
- 0: The DPLLRRATIO register has been synchronized.
- 1: The DPLLRRATIO register value has changed and its synchronization is in progress.

**Bit 1 - ENABLE** DPLL Enable Synchronization Status

- 0: The DPLLnCTRLA.ENABLE bit has been synchronized.
- 1: The DPLLnCTRLA.ENABLE bit value has changed and its synchronization is in progress.

### 18.7.16 DPLL Status

**Name:** DPLLSTATUS  
**Offset:** 0x40 + n\*0x14 [n=0..1]  
**Reset:** 0x00000000



**Bit 1 - CLKRDY** DPLL Clock Ready  
 0: The DPLLn output clock is off.  
 1: The DPLLn output clock in on.

**Bit 0 - LOCK** DPLL Lock Status  
 0: The DPLLn Lock signal is cleared, when the DPLLn is disabled or when the DPLLn is trying to reach the target frequency.  
 1: The DPLLn Lock signal is asserted when the desired frequency is reached.

## 19. Supply Controller (SUPC)

### 19.1 Overview

The Supply Controller (SUPC) manages the voltage reference, power supply, and supply monitoring of the device. It is also able to control two output pins.

The SUPC controls the voltage regulators for the core (VDDCORE) and backup (VDDBU) domains. It sets the voltage regulators according to the sleep modes, or the user configuration. In active mode, the voltage regulators can be selected on-the-fly between LDO (low-dropout) type regulator or Buck converter.

The SUPC supports connection of a battery backup to the VBAT power pin. It includes functionality that enables automatic power switching between main power and battery backup power. This ensures power to the backup domain when the main battery or power source is unavailable.

The SUPC embeds two Brown-Out Detectors: BOD33 monitors the voltage applied to the device (VDD or VBAT) and BOD12 monitors the internal voltage to the core (VDDCORE). The BOD33 can monitor the supply voltage continuously (continuous mode) or periodically (sampling mode), in normal or low power mode.

The SUPC generates also a selectable reference voltage, which can be used by analog modules such as the ADC and DAC.

### 19.2 Features

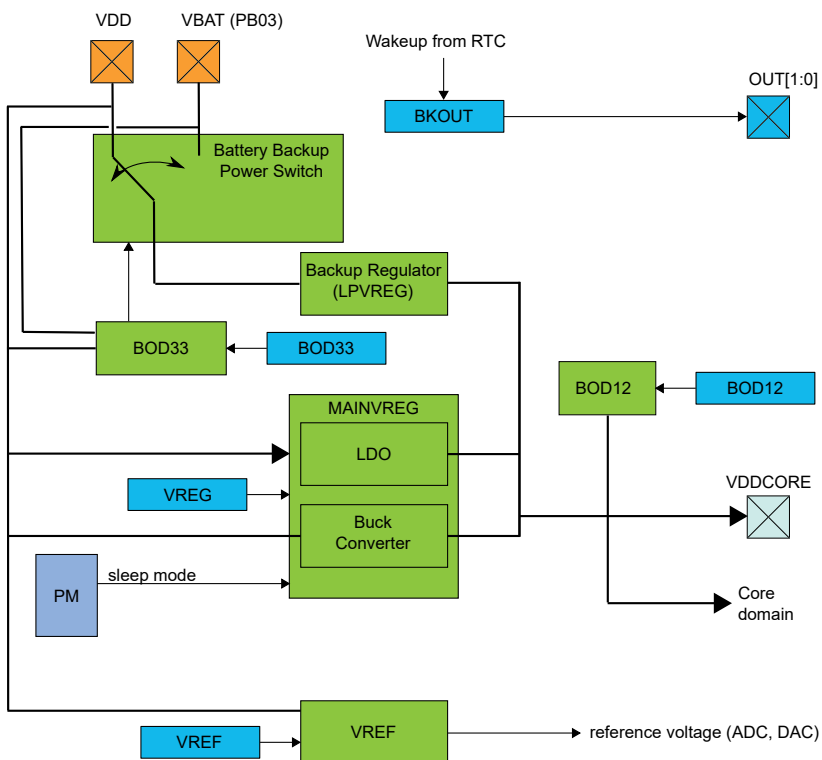
The following are key features of the SUPC:

- Voltage Regulator System
  - Main voltage regulator: LDO or Buck Converter in Active, Standby, or Hibernate mode (MAINVREG)
  - Low-Power voltage regulator in Backup mode (LPVREG)
  - Controlled VDDCORE voltage slope when changing VDDCORE
- Battery Backup Power Switch
  - Automatic switching from main power to battery backup power
    - Automatic entry to Backup mode when switched to battery backup power
  - Automatic switching from battery backup power to main power
    - Automatic exit from Backup mode when switched back to main power
    - Stay in Backup mode when switched back to main power
- Voltage Reference System
  - Reference voltage for ADC and DAC
- 3.3V Brown-out Detector (BOD33)
  - Programmable threshold
  - Threshold value loaded from NVM User Row at startup
  - Triggers resets, interrupts, or Battery Backup Power Switch. Action loaded from NVM User Row
  - Operating modes:
    - Continuous mode
    - Low-Power and Sampled modes for low-power applications with programmable sample frequency
  - Hysteresis value from Flash User Calibration

- Monitor VDD or VBAT (PB03)
- 1.2V Brown-out Detector (BOD12)
- Output pins
  - Pin toggling on RTC event

## 19.3 Block Diagram

Figure 19-1. SUPC Block Diagram



## 19.4 Signal Description

Signal	I/O Pin	Name	Type	Description
OUT[0]	PB01	Digital Output	SUPC Output 0	
OUT[1]	PB02	Digital Output	SUPC Output 1	

**Note:** The PB01 and PB02 pins are BACKUP I/O pins.

## 19.5 Peripheral Dependencies

<b>Peripheral Name</b>	SUPC – Supply Controller
<b>Base Address</b>	0x4000_1800 (Peripheral Bus A)
<b>NVIC IRQ Index:Source</b>	8 : BOD33RDY, B33SRDY, VCORERDY, VREGRDY 9 : BOD33DET
<b>MCLK APB Clock (1)</b>	CLK_SUPC_APB, Enabled, APBAMASK.SUPC
<b>GCLK Peripheral Channel Index:Clock Name</b>	n/a
<b>PAC Peripheral Identifier (PAC.WRCTRL)</b>	6
<b>Note:</b>	
1.	Clock Name, Default State, Mask Field.



### 19.5.1 Power Management

The SUPC can operate in all sleep modes except Backup Sleep mode. BOD33 and Battery Backup Power Switch can operate in Backup mode.

### 19.5.2 Clocks

The SUPC bus clock (CLK\_SUPC\_APB) can be enabled and disabled in the Main Clock module (MCLK.APBAMASK.SUPC).

A 32.768 kHz clock, asynchronous to the user interface clock (CLK\_SUPC\_APB), is required to run BOD33 and BOD12 in sampled mode. Due to this asynchronicity, writing to certain registers will require synchronization between the clock domains. Refer to [19.6.7. Synchronization](#) for further details.

### 19.5.3 Debug Operation

When the CPU is halted in Debug mode, the SUPC continues normal operation. If the SUPC is configured in a way that requires it to be periodically serviced by the CPU through interrupts or similar, improper operation or data loss may result during debugging.

If a cold plug-in is detected by the system, BOD33 and BOD12 will use the factory calibration setting instead of the user calibration. In hot plug-in, the BODs resets keep running.

### 19.5.4 Register Access Protection

Registers with write access can be write-protected optionally by the [Peripheral Access Controller \(PAC\)](#).

PAC write protection is not available for the following registers:

- Interrupt Flag register ([INTFLAG](#))

Optional PAC write protection is denoted by the "PAC Write-Protection" property in each individual register description.

## 19.6 Functional Description

The PIC32CX SG41/SG60/SG61 internal Main Voltage Regulator has three different modes:

- **Linear mode:** This is the default mode when CPU and peripherals are running. It does not require an external inductor.
- **Switching mode:** This is the most power efficient mode when the CPU and peripherals are running, which requires an external inductor between VSW and VDDCORE. This mode can be selected by software on the fly.
- **Shutdown mode:** When the chip is in backup mode, the internal regulator is off, the VSW core power domain is OFF. The VDDBU backup domain is powered by the backup regulator (LPVREG).

**Note:** The Voltage Regulator modes are controlled by the Power Manager.

### 19.6.1 Voltage Regulators System Operation

#### 19.6.1.1 Enabling, Disabling, and Resetting

The LDO main voltage regulator is enabled after a Power-on-Reset. The main voltage regulator output supply level is automatically defined by the Sleep mode selected in the [Power Manager](#) module (PM.SLEEP\_CFG.SLEEP\_MODE).

#### 19.6.1.2 Initialization

After a Power-on-Reset, the LDO voltage regulator supplying VDDCORE is enabled.

#### 19.6.1.3 Selecting the Main Voltage Regulator

In Active mode, the type of the main voltage regulator supplying VDDCORE can be switched on the fly. The two alternatives are a LDO regulator and a Buck converter.

The main voltage regulator switching sequences are as follows:

- The user changes the value of the Voltage Regulator Selection bit in the Voltage Regulator System Control register (VREG.SEL)
- The start of the switching sequence is indicated by clearing the Voltage Regulator Ready bit in the STATUS register (STATUS.VREGRDY=0)
- Once the switching sequence is completed, STATUS.VREGRDY will read '1'

The Voltage Regulator Ready (VREGRDY) interrupt can also be used to detect a zero-to-one transition of the STATUS.VREGRDY bit.

#### 19.6.1.4 Voltage Scaling Control

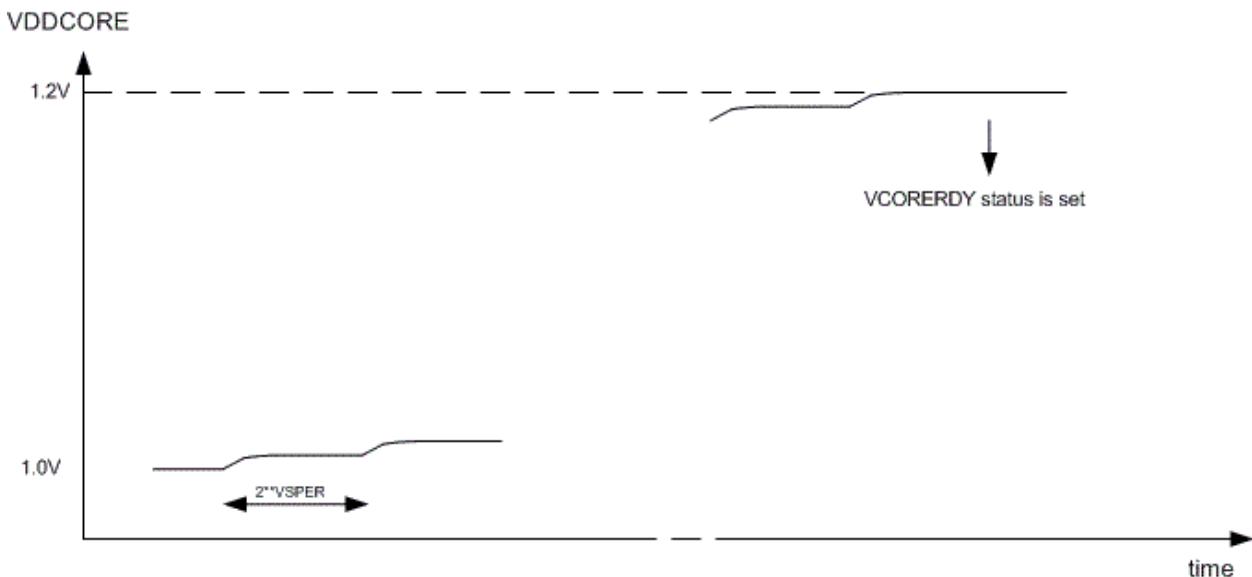
The VDDCORE supply will change under these circumstances:

- When a Sleep mode (Standby, Hibernate, Backup) is entered or exited
- When a sleepwalking task is requested in Standby mode

To prevent high peak current on the main power supply and to have a smooth transition of VDDCORE, the Voltage Scaling Period field in VREG (VREG.VSPER) can be controlled: VDDCORE is changed by a typical 5 mV of the selected voltage scaling period ( $2^{VSPER} * T$ ) until the target voltage is reached.

The smooth transition of VDDCORE is enabled/disabled by setting/clearing the Voltage Scaling Enable bit in VREG (VREG.VSEN).

The following waveform shows an example of exiting the Standby Sleep mode.



The STATUS.VCORERDY bit is set to '1' as soon as the VDDCORE voltage has reached the target voltage. During voltage transition, STATUS.VCORERDY will read '0'. The Voltage Ready interrupt (VCORERDY) can be used to detect a 0-to-1 transition of STATUS.VCORERDY, see also "Interrupts".

When entering the Standby, Hibernate, or Backup Sleep mode, and when no sleepwalking task is requested, the VDDCORE Voltage scaling control is not used. This means that the voltage scale rise rate control (smooth transition) operates only when the device exits from sleep modes, and when the device is already in standby sleep mode and sleep walking is requested.

#### 19.6.1.5 Sleep Mode Operation

In Standby and Hibernate mode, the main voltage regulator (MAINVREG) operates in low power mode.

In backup mode, the low-power voltage regulator (LPVREG) is used to supply VDDCORE.

## 19.6.2 Voltage Reference System Operation

Different reference voltages are generated by the SUPC:

- A fixed-voltage source: BANDGAP=1.1V
- A variable voltage: VREF

### 19.6.2.1 Initialization

The voltage reference output is disabled after any Reset.

### 19.6.2.2 Enabling, Disabling, and Resetting

The voltage reference output is enabled or disabled by setting or clearing the Voltage Reference Output Enable bit in the Voltage Reference register (VREF.VREFOE).

### 19.6.2.3 Selecting a Voltage Reference

The Voltage Reference Selection bit field in the VREF register (VREF.SEL) selects the voltage of VREF to be applied to analog modules, for example, ADC.

### 19.6.2.4 Sleep Mode Operation

The Voltage Reference output behavior during sleep mode can be configured using the Run in Standby bit and the On Demand bit in the Voltage Reference register (VREF.RUNSTDBY, VREF.ONDEMAND), refer to the table below:

**Table 19-1.** VREF Sleep Mode Operation

VREF.ONDEMAND	VREF.RUNSTDBY	Voltage Reference Sleep behavior
0	0	Always run in all sleep modes <i>except</i> Standby Sleep mode
0	1	Always run in all sleep modes <i>including</i> Standby Sleep mode
1	0	Only run if requested by the ADC, in all sleep modes <i>except</i> Standby Sleep mode
1	1	Only run if requested by the ADC, in all sleep modes <i>including</i> Standby Sleep mode

## 19.6.3 Battery Backup Mode

### 19.6.3.1 Battery Backup Power Switch

The Battery Backup Power Switch (BBPS) is disabled at power-up, and the backup domain is supplied by main power.

### 19.6.3.2 Automatic Battery Backup Power Switch

The supply of the backup domain can be switched automatically to VBAT supply pin by the Battery Backup Power Switch when the BOD33 detects that the VDD supply is below the VDD threshold level (BOD33.LEVEL). It is switched back to VDD supply pin when the BOD33 detects that VDD is above the VDD threshold level (BOD33.LEVEL).

To enable this feature, the following configuration is required: BOD33.ACTION=BKUP.

### 19.6.3.3 Enabling Battery Backup Mode

Enabling backup mode can be done by either:

- Enabling the Automatic Battery Backup Power Switch (BOD33.ACTION=BKUP)
- Configuring the Battery Backup Power Switch in forced mode: BBPS.CONF=FORCED



**Important:** The RTC must always be configured and enabled before enabling the Battery Backup mode.

#### 19.6.3.3.1 Entering Battery Backup Mode

Entering backup mode can be triggered by either:

- Wait-for-interrupt (WFI) instruction with the Power Manager (PM) configuration bit: SLEEPCFG.SLEEPMODE=BACKUP (if BBPS.CONF=FORCED)
- BOD33 detection: When the BOD33 detects loss of Main Power, the Backup Domain will be powered by battery and the device will enter the backup mode. For this trigger, the following register configuration is required: BOD33.ACTION=BKUP.

### 19.6.3.3.2 Leaving Battery Backup Mode

Leaving backup mode is triggered by the RSTC when a Backup Mode Exit condition occurs. See RSTC module for details.

- BOD33 exit condition: When the BOD33 detects Main Power is restored and BOD33.ACTION=BKUP:
  - When BBPS.WAKEEN=1, the device will leave backup mode and wake up.
  - When BBPS.WAKEEN=0, the backup domain will be powered by Main Power, but the device will stay in backup mode.
- For other exit condition (RTC): The device is kept in battery-powered backup mode until Main Power is restored to supply the device. Then, the backup domain will be powered by Main Power.

### 19.6.4 Output Pins

The SUPC can drive two backup pin outputs. By writing a '1' to the corresponding Output Enable bit in the Backup Output Control register (BKOUT.EN), the OUTx pin is driven by the SUPC.

The OUTx pin can be set by writing a '1' to the corresponding Set Output bit in the Backup Output Control register (BKOUT.SETx).

The OUTx pin can be cleared by writing a '1' to the corresponding CLR bit (BKOUT.CLRx).

If a RTC Toggle Enable bit is written to '1' (BKOUT.RTCTGLx), the corresponding OUTx pin will toggle when an RTC event occurs.

The BKIN.BKINx bit reflects the state of corresponding OUTx pins.

### 19.6.5 Brown-out Detectors (BOD)

#### 19.6.5.1 Initialization

Before a Brown-out Detector (BOD33) is enabled, it must be configured, as outlined by the following:

- Set the BOD threshold level (BOD33.LEVEL)
- Set the configuration in Active, Standby, Hibernate, and Backup modes (BOD33.ACTION, BOD33.STDBYCFG, BOD33.BKUP, BOD33.RUNHIB, and BOD33.RUNBKUP)
- Set the prescaling value if the BOD will run in sampling mode (BOD33.PSEL)
- Set the action and hysteresis (BOD33.ACTION and BOD33.HYST)

The BOD33 register is Enable-Protected (excluding BOD33.ENABLE bit), meaning that they can only be written when the BOD is disabled (BOD33.ENABLE = 0 and STATUS.B33SRDY = 0). As long as the Enable bit is '1', any writes to Enable-Protected registers (EVCTRL) will be discarded, and an APB error will be generated. The Enable bits are not Enable-Protected.

#### 19.6.5.2 Enabling, Disabling, and Resetting

After a Power-on Reset or user reset, the BOD33 and BOD12 register values are loaded from the NVM User Row.

The BOD33 is enabled by writing a '1' to the Enable bit in the BOD control register (BOD33.ENABLE). The BOD33 is disabled by writing a '0' to the BOD33.ENABLE.

#### 19.6.5.3 3.3V Brown-out Detector (BOD33)

The 3.3V Brown-out Detector (BOD33) is able to monitor either the VDD or the VBAT supply and compares the voltage with the brown-out threshold levels.

In all mode except battery Backup mode, the BOD33 compares the VDD voltage with the brown-out threshold level. This level is set in the BOD33 Level field in the BOD33 register (BOD33.LEVEL). When VDD crosses below the brown-out threshold level, the BOD33 can generate either an interrupt, or a Reset, or an Automatic Battery Backup Power Switch, depending on the BOD33 Action bit field (BOD33.ACTION).

In battery Backup mode, the BOD33 monitors both the VBAT and VDD supplies alternatively. When VBAT crosses below the backup brown-out threshold level (BOD33.VBATLEVEL), the BOD33 generates a Power Supply Reset. When VDD crosses above the brown-out threshold level (BOD33.LEVEL), the device will leave battery Backup mode and will wake up from Backup mode if the BBPS.WAKEEN bit is set.

The BOD33 detection status can be read from the BOD33 Detection bit in the Status register (STATUS.BOD33DET).

At start-up or at Power-on Reset (POR), the BOD33 register values are loaded from the NVM User Row.

### 19.6.5.3.1 BOD33 Sampling Mode

The sampling mode is a Low-Power mode where the BOD33 is being repeatedly enabled on a sampling clock's ticks. The BOD33 will monitor the supply voltage (VDD or VBAT) for a short period of time and then go to a low-power disabled state until the next sampling clock tick.

Sampling mode is enabled in Backup or Hibernate mode by writing to the BOD33 bits (BOD33.BKUPCFG = 1 or BOD33.HIBCFG = 1). The frequency of the clock ticks ( $F_{clk_{sampling}}$ ) is controlled by the Prescaler Select bit groups in the BOD33 register (BOD33.PSEL).

$$F_{clk_{sampling}} = \frac{F_{clk_{prescaler}}}{2^{(PSEL+1)}}$$

The prescaler signal ( $F_{clk_{prescaler}}$ ) is a 32.768 kHz clock, output by the 32 kHz Ultra Low-Power Oscillator OSCULP32K.

**Note:** If (BOD33.PSEL) is 0, sampling mode is disabled.

As the sampling clock is different from the APB clock domain, synchronization among the clocks is necessary. See 19.6.7. [Synchronization](#) for additional information.

### 19.6.5.3.2 BOD33 Low-Power Mode

BOD33 Low-Power mode is automatically enabled in Backup or Hibernate Sleep mode.

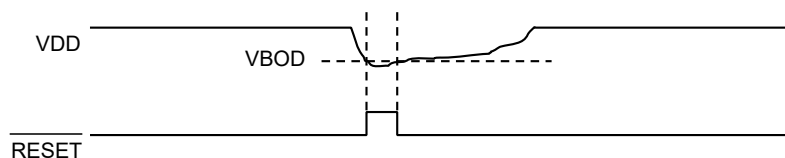
BOD33 Low-Power mode can be enabled in Standby Sleep mode by writing to '1' the BOD33.STDBYCFG bit.

### 19.6.5.3.3 BOD33 Hysteresis

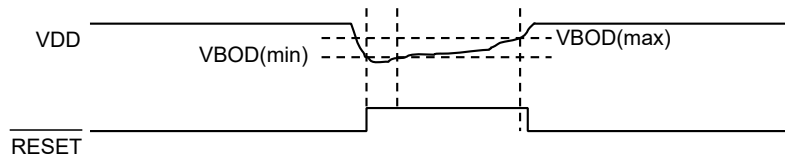
A hysteresis on the trigger threshold of a BOD will reduce the sensitivity to ripples on the monitored voltage: instead of switching **RESET** at each crossing of  $V_{BOD}$ , the thresholds for switching **RESET** on and off are separated ( $V_{BOD}(\min)$  and  $V_{BOD}(\max)$ , respectively).

**Figure 19-2.** BOD Hysteresis Principle

Hysteresis OFF:



Hysteresis ON:



Enabling the BOD33 hysteresis by writing the Hysteresis bit field in the BOD33 register (BOD33.HYST) to a non-null value will add hysteresis to the BOD33 threshold level.

**Notes:**

1. The hysteresis functionality can be used in Sampling Mode.
2. The hysteresis feature is not functional while the device is in STANDBY sleep mode.

**19.6.5.3.4 Standby Sleep Mode**

The BOD33 can be used in Standby mode if the BOD is enabled and the Run in Standby bit is written to '1' (BOD33.RUNSTDBY).

It is set in Low-Power mode if the BOD33.STDBYCFG bit is written to '1'.

**19.6.5.3.5 Backup and Hibernate sleep Modes**

To enable the BOD33 in Backup or Hibernate Sleep mode, the Run in Backup or Hibernate Sleep mode bits in the BOD33 register (BOD33.RUNBKUP, BOD33.RUNHIB) must be written to '1'. The BOD33 is automatically set in BOD33 Ultra Low-Power mode. Additionally, the BOD33 will operate in Sampling mode if the BOD33.PSEL bit is non-null. In this state, the voltage monitored by BOD33 is always the supply of the backup domain, that is VDD or VBAT.

**19.6.5.4 1.2V Brown-out Detector (BOD12)**

The BOD12 is calibrated in production and its calibration configuration is stored in the NVM User Row. This configuration must not be changed to assure the correct behavior of the BOD12. The BOD12 generates a reset when VDDCORE crosses below the preset brown-out level. The BOD12 is always disabled in Standby, Hibernate, and Backup Sleep modes.

**19.6.6 Interrupts**

The SUPC has the following interrupt sources, which are either synchronous or asynchronous wake-up sources:

- VDDCORE Voltage Ready (VCORERDY), asynchronous
- Voltage Regulator Ready (VREGRDY) asynchronous
- BOD33 Ready (BOD33RDY), synchronous
- BOD33 Detection (BOD33DET), asynchronous
- BOD33 Synchronization Ready (B33SRDY), synchronous

Each interrupt source has an interrupt flag associated with it. The interrupt flag in the Interrupt Flag Status and Clear register (INTFLAG) is set when the interrupt condition occurs.

Each interrupt can be individually enabled by writing a '1' to the corresponding bit in the Interrupt Enable Set register (INTENSET), and disabled by writing a '1' to the corresponding bit in the Interrupt Enable Clear register (INTENCLR).

An interrupt request is generated when the interrupt flag is set and the corresponding interrupt is enabled. The interrupt request remains active until either the interrupt flag is cleared, the interrupt is disabled, or the SUPC is reset. See the INTFLAG register for details on how to clear interrupt flags. The user must read the INTFLAG register to determine which interrupt condition is present.

**Note:** Interrupts must be globally enabled for interrupt requests to be generated.

### 19.6.7 Synchronization

The prescaler counters that are used to trigger brown-out detections operate asynchronously from the peripheral bus. As a consequence, the BOD33 Enable bit (BOD33.ENABLE) need synchronization when written.

The Write-Synchronization of the Enable bit is triggered by writing a '1' to the Enable bit of the BOD33 Control register. The Synchronization Ready bit (STATUS.B33SRDY) in the STATUS register will be cleared when the Write-Synchronization starts, and set again when the Write-Synchronization is complete. Writing to the same register while the Write-Synchronization is ongoing (STATUS.B33SRDY is '0') will generate a PAC error without stalling the APB bus.

## 19.7 Register Summary

Offset	Name	Bit Pos.	7	6	5	4	3	2	1	0
0x00	INTENCLR	7:0						B33SRDY	BOD33DET	BOD33RDY
		15:8						VCORERDY		VREGRDY
		23:16								
		31:24								
0x04	INTENSET	7:0						B33SRDY	BOD33DET	BOD33RDY
		15:8						VCORERDY		VREGRDY
		23:16								
		31:24								
0x08	INTFLAG	7:0						B33SRDY	BOD33DET	BOD33RDY
		15:8						VCORERDY		VREGRDY
		23:16								
		31:24								
0x0C	STATUS	7:0						B33SRDY	BOD33DET	BOD33RDY
		15:8						VCORERDY		VREGRDY
		23:16								
		31:24								
0x10	BOD33	7:0	RUNBKUP	RUNHIB	RUNSTDBY	STDBYCFG	ACTION[1:0]		ENABLE	
		15:8		PSEL[2:0]		HYST[3:0]				
		23:16	LEVEL[7:0]							
		31:24	VBATLEVEL[7:0]							
0x14 ... 0x17	Reserved									
0x18	VREG	7:0	RUNBKUP					SEL	ENABLE	
		15:8								
		23:16								VSEN
		31:24						VSPER[2:0]		
0x1C	VREF	7:0	ONDEMAND	RUNSTDBY				VREFOE		
		15:8								
		23:16					SEL[3:0]			
		31:24								
0x20	BBPS	7:0						WAKEEN		CONF
		15:8								
		23:16								
		31:24								
0x24	BKOUT	7:0							ENOUT1	ENOUT0
		15:8							CLROUT1	CLROUT0
		23:16							SETOUT1	SETOUT0
		31:24							RTCTGLOUT1	RTCTGLOUT0
0x28	BKIN	7:0							BKIN1	BKIN0
		15:8								
		23:16								
		31:24								



### 19.7.1 Interrupt Enable Clear

**Name:** INTENCLR  
**Offset:** 0x00  
**Reset:** 0x00000000  
**Property:** PAC Write-Protection

This register allows the user to disable an interrupt without doing a read-modify-write operation. Changes in this register will also be reflected in the Interrupt Enable Set register (INTENSET).

Bit	31	30	29	28	27	26	25	24
Access								
Reset								
Bit	23	22	21	20	19	18	17	16
Access								
Reset								
Bit	15	14	13	12	11	10	9	8
Access						VCORERDY		VREGRDY
Reset						R/W		R/W
						0		0
Bit	7	6	5	4	3	2	1	0
Access						B33SRDY	BOD33DET	BOD33RDY
Reset						R/W	R/W	R/W
						0	0	0

#### Bit 10 - VCORERDY VDDCORE Voltage Ready Interrupt Enable

Writing a '0' to this bit has no effect.

Writing a '1' to this bit will clear the VDDCORE Ready Interrupt Enable bit, which disables the VDDCORE Ready interrupt.

Value	Description
0	The VDDCORE Ready interrupt is disabled.
1	The VDDCORE Ready interrupt is enabled and an interrupt request will be generated when the VCORERDY Interrupt Flag is set.

#### Bit 8 - VREGRDY Voltage Regulator Ready Interrupt Enable

Writing a '0' to this bit has no effect.

Writing a '1' to this bit will clear the Voltage Regulator Ready Interrupt Enable bit, which disables the Voltage Regulator Ready interrupt.

Value	Description
0	The Voltage Regulator Ready interrupt is disabled.
1	The Voltage Regulator Ready interrupt is enabled and an interrupt request will be generated when the Voltage Regulator Ready Interrupt Flag is set.

#### Bit 2 - B33SRDY BOD33 Synchronization Ready Interrupt Enable

Writing a '0' to this bit has no effect.

Writing a '1' to this bit will clear the BOD33 Synchronization Ready Interrupt Enable bit, which disables the BOD33 Synchronization Ready interrupt.

Value	Description
0	The BOD33 Synchronization Ready interrupt is disabled.

Value	Description
1	The BOD33 Synchronization Ready interrupt is enabled, and an interrupt request will be generated when the BOD33 Synchronization Ready Interrupt flag is set.

**Bit 1 – BOD33DET** BOD33 Detection Interrupt Enable

Writing a '0' to this bit has no effect.

Writing a '1' to this bit will clear the BOD33 Detection Interrupt Enable bit, which disables the BOD33 Detection interrupt.

Value	Description
0	The BOD33 Detection interrupt is disabled.
1	The BOD33 Detection interrupt is enabled, and an interrupt request will be generated when the BOD33 Detection Interrupt flag is set.

**Bit 0 – BOD33RDY** BOD33 Ready Interrupt Enable

Writing a '0' to this bit has no effect.

Writing a '1' to this bit will clear the BOD33 Ready Interrupt Enable bit, which disables the BOD33 Ready interrupt.

Value	Description
0	The BOD33 Ready interrupt is disabled.
1	The BOD33 Ready interrupt is enabled, and an interrupt request will be generated when the BOD33 Ready Interrupt flag is set.

## 19.7.2 Interrupt Enable Set

**Name:** INTENSET  
**Offset:** 0x04  
**Reset:** 0x00000000  
**Property:** PAC Write-Protection

This register allows the user to disable an interrupt without doing a read-modify-write operation. Changes in this register will also be reflected in the Interrupt Enable Clear register (INTENCLR).

Bit	31	30	29	28	27	26	25	24
Access								
Reset								
Bit	23	22	21	20	19	18	17	16
Access								
Reset								
Bit	15	14	13	12	11	10	9	8
Access						VCORERDY		VREGRDY
Reset						R/W		R/W
						0		0
Bit	7	6	5	4	3	2	1	0
Access						B33SRDY	BOD33DET	BOD33RDY
Reset						R/W	R/W	R/W
						0	0	0

### Bit 10 – VCORERDY VDDCORE Voltage Ready Interrupt Enable

Writing a '0' to this bit has no effect.

Writing a '1' to this bit will set the VDDCORE Ready Interrupt Enable bit, which enables the VDDCORE Ready interrupt.

Value	Description
0	The VDDCORE Ready interrupt is disabled.
1	The VDDCORE Ready interrupt is enabled and an interrupt request will be generated when the VCORERDY Interrupt Flag is set.

### Bit 8 – VREGRDY Voltage Regulator Ready Interrupt Enable

Writing a '0' to this bit has no effect.

Writing a '1' to this bit will set the Voltage Regulator Ready Interrupt Enable bit, which enables the Voltage Regulator Ready interrupt.

Value	Description
0	The Voltage Regulator Ready interrupt is disabled.
1	The Voltage Regulator Ready interrupt is enabled and an interrupt request will be generated when the Voltage Regulator Ready Interrupt Flag is set.

### Bit 2 – B33SRDY BOD33 Synchronization Ready Interrupt Enable

Writing a '0' to this bit has no effect.

Writing a '1' to this bit will set the BOD33 Synchronization Ready Interrupt Enable bit, which enables the BOD33 Synchronization Ready interrupt.

Value	Description
0	The BOD33 Synchronization Ready interrupt is disabled.

Value	Description
1	The BOD33 Synchronization Ready interrupt is enabled, and an interrupt request will be generated when the BOD33 Synchronization Ready Interrupt flag is set.

**Bit 1 – BOD33DET** BOD33 Detection Interrupt Enable

Writing a '0' to this bit has no effect.

Writing a '1' to this bit will set the BOD33 Detection Interrupt Enable bit, which enables the BOD33 Detection interrupt.

Value	Description
0	The BOD33 Detection interrupt is disabled.
1	The BOD33 Detection interrupt is enabled, and an interrupt request will be generated when the BOD33 Detection Interrupt flag is set.

**Bit 0 – BOD33RDY** BOD33 Ready Interrupt Enable

Writing a '0' to this bit has no effect.

Writing a '1' to this bit will set the BOD33 Ready Interrupt Enable bit, which enables the BOD33 Ready interrupt.

Value	Description
0	The BOD33 Ready interrupt is disabled.
1	The BOD33 Ready interrupt is enabled, and an interrupt request will be generated when the BOD33 Ready Interrupt flag is set.

### 19.7.3 Interrupt Flag Status and Clear

**Name:** INTFLAG  
**Offset:** 0x08  
**Reset:** 0x0000010X  
**Property:** -

In the reset value: X= determined from NVM User Row (0xX=0bx00y)

Bit	31	30	29	28	27	26	25	24
Access								
Reset								
Bit	23	22	21	20	19	18	17	16
Access								
Reset								
Bit	15	14	13	12	11	10	9	8
Access						VCORERDY		VREGRDY
Reset						R/W		R/W
						0		0
Bit	7	6	5	4	3	2	1	0
Access						B33SRDY	BOD33DET	BOD33RDY
Reset						R/W	R/W	R/W
						0	0	y

#### Bit 10 - VCORERDY VDDCORE Voltage Ready

This flag is cleared by writing a '1' to it.

This flag is set on a zero-to-one transition of the VDDCORE Ready bit in the Status register (STATUS.VCORERDY) and will generate an interrupt request if INTENSET.VCORERDY=1.

Writing a '0' to this bit has no effect.

Writing a '1' to this bit clears the VCORERDY interrupt flag.

#### Bit 8 - VREGRDY Voltage Regulator Ready

This flag is cleared by writing a '1' to it.

This flag is set on a zero-to-one transition of the Voltage Regulator Ready bit in the Status register (STATUS.VREGRDY) and will generate an interrupt request if INTENSET.VREGRDY=1.

Writing a '0' to this bit has no effect.

Writing a '1' to this bit clears the VREGRDY interrupt flag.

#### Bit 2 - B33SRDY BOD33 Synchronization Ready

This flag is cleared by writing a '1' to it.

This flag is set on a zero-to-one transition of the BOD33 Synchronization Ready bit in the Status register (STATUS.B33SRDY) and will generate an interrupt request if INTENSET.B33SRDY=1.

Writing a '0' to this bit has no effect.

Writing a '1' to this bit clears the BOD33 Synchronization Ready interrupt flag.

#### Bit 1 - BOD33DET BOD33 Detection

This flag is cleared by writing a '1' to it.

This flag is set on a zero-to-one transition of the BOD33 Detection bit in the Status register (STATUS.BOD33DET) and will generate an interrupt request if INTENSET.BOD33DET=1.

Writing a '0' to this bit has no effect.  
Writing a '1' to this bit clears the BOD33 Detection interrupt flag.

**Bit 0 – BOD33RDY** BOD33 Ready

This flag is cleared by writing a '1' to it.

This flag is set on a zero-to-one transition of the BOD33 Ready bit in the Status register (STATUS.BOD33RDY) and will generate an interrupt request if INTENSET.BOD33RDY=1.

Writing a '0' to this bit has no effect.

Writing a '1' to this bit clears the BOD33 Ready interrupt flag.

The BOD33 can be enabled.

## 19.7.4 Status

**Name:** STATUS  
**Offset:** 0x0C  
**Reset:** Determined from NVM User Row  
**Property:** -

Bit	31	30	29	28	27	26	25	24
Access								
Reset								
Bit	23	22	21	20	19	18	17	16
Access								
Reset								
Bit	15	14	13	12	11	10	9	8
Access						VCORERDY		VREGRDY
Reset						R		R
						1		1
Bit	7	6	5	4	3	2	1	0
Access						B33SRDY	BOD33DET	BOD33RDY
Reset						R	R	R
						1	0	y

### Bit 10 - VCORERDY VDDCORE Voltage Ready

Value	Description
0	the VDDCORE voltage is not as expected.
1	the VDDCORE voltage is the target voltage.

### Bit 8 - VREGRDY Voltage Regulator Ready

Value	Description
0	The selected voltage regulator in VREG.SEL is not ready.
1	The voltage regulator selected in VREG.SEL is ready and the core domain is supplied by this voltage regulator.

### Bit 2 - B33SRDY BOD33 Synchronization Ready

Value	Description
0	BOD33 synchronization is ongoing.
1	BOD33 synchronization is complete.

### Bit 1 - BOD33DET BOD33 Detection

Value	Description
0	No BOD33 detection.
1	BOD33 has detected that the I/O power supply is going below the BOD33 reference value.

### Bit 0 - BOD33RDY BOD33 Ready

The BOD33 can be enabled at start-up from NVM User Row.

Value	Description
0	BOD33 is not ready.
1	BOD33 is ready.

### 19.7.5 3.3V Brown-Out Detector (BOD33) Control

**Name:** BOD33  
**Offset:** 0x10  
**Reset:** Determined from NVM User Row  
**Property:** Write-Synchronized Bit(s), PAC Write-Protection

Bit	31	30	29	28	27	26	25	24
	VBATLEVEL[7:0]							
Access	R/W	R/W	R/W	R/W	R/W	R/W	R/W	R/W
Reset	0	0	0	0	0	0	0	0
Bit	23	22	21	20	19	18	17	16
	LEVEL[7:0]							
Access	R/W	R/W	R/W	R/W	R/W	R/W	R/W	R/W
Reset	0	0	x	x	x	x	x	x
Bit	15	14	13	12	11	10	9	8
		PSEL[2:0]			HYST[3:0]			
Access		R/W	R/W	R/W	R/W	R/W	R/W	R/W
Reset		0	0	0	x	x	x	x
Bit	7	6	5	4	3	2	1	0
	RUNBKUP	RUNHIB	RUNSTDBY	STDBYCFG	ACTION[1:0]		ENABLE	
Access	R/W	R/W	R/W	R/W	R/W	R/W	R/W	
Reset	0	0	0	0	y	y	z	

#### Bits 31:24 – VBATLEVEL[7:0] BOD33 Threshold Level on VBAT

This field sets the triggering voltage threshold for the BOD33 when the BOD33 monitors VBAT in battery backup sleep mode.  
 This field is not synchronized.

#### Bits 23:16 – LEVEL[7:0] BOD33 Threshold Level on VDD

This field sets the triggering voltage threshold for the BOD33 when the BOD33 monitors VDD. If an hysteresis value is programmed (BOD33.HYST), this field corresponds to the lower threshold VBOD(min).

These bits are loaded from NVM User Row at start-up.

This field is not synchronized.

$$VBOD(\min) = (1.5 + (\text{SUPC.BOD33.LEVEL}[7:0] * VBOD33_{\text{LEVEL\_STEP}}))$$

$$VBOD(\max) = (VBOD(\min) + (\text{SUPC.BOD33.HYST}[3:0] * VBOD33_{\text{HYST\_STEP}}))$$

If a hysteresis value is programmed, the following equation must be respected to avoid any overflow on VBOD(max) : LEVEL[7:0] value  $\leq$  255 - HYST[3:0] value

#### Bits 14:12 – PSEL[2:0] Prescaler Select

Selects the prescaler divide-by output for the BOD33 sampling mode available in hibernate, backup or battery backup mode. The input clock comes from the OSCULP32K 32.768 kHz output.

Value	Name	Description
0x0	NODIV	Not divided: Sampling mode is OFF.
0x1	DIV4	Divide clock by 4
0x2	DIV8	Divide clock by 8
0x3	DIV16	Divide clock by 16
0x4	DIV32	Divide clock by 32
0x5	DIV64	Divide clock by 64
0x6	DIV128	Divide clock by 128



Value	Name	Description
0x7	DIV256	Divide clock by 256

**Bits 11:8 – HYST[3:0]** BOD33 Hysteresis Voltage Value on  $V_{DD}$   
This field sets the hysteresis voltage value related to "BOD33 Threshold Level on VDD" field when the BOD33 monitors VDD.  
These bits are loaded from NVM User Row at start-up.  
This field is not synchronized.

**Note:** The hysteresis feature is not functional while the device is in STANDBY sleep mode.

Value	Description
0	No hysteresis.
N	Hysteresis value is set to $N \cdot VBOD33_{HYST\_STEP}$ . See the Electrical Characteristics section for the $VBOD33_{HYST\_STEP}$ voltage level.

**Bit 7 – RUNBKUP** BOD33 Configuration in Backup Sleep Mode  
This field is not synchronized.

Value	Description
0	In backup sleep mode, the BOD33 is disabled.
1	In backup sleep mode, the BOD33 is enabled and configured in sampling mode.

**Bit 6 – RUNHIB** BOD33 Configuration in Hibernate Sleep Mode  
This field is not synchronized.

Value	Description
0	In hibernate sleep mode, the BOD33 is disabled.
1	In hibernate sleep mode, the BOD33 is enabled and configured in sampling mode.

**Bit 5 – RUNSTDBY** Run in Standby  
This bit is not synchronized.

Value	Description
0	In standby sleep mode, the BOD33 is disabled.
1	In standby sleep mode, the BOD33 is enabled.

**Bit 4 – STDBYCFG** BOD33 Configuration in Standby Sleep Mode  
If the RUNSTDBY bit is set to '1', the STDBYCFG bit sets the BOD33 configuration in standby sleep mode.  
This field is not synchronized.

Value	Description
0	In standby sleep mode, the BOD33 is enabled and configured in normal mode.
1	In standby sleep mode, the BOD33 is enabled and configured in low power mode.

**Bits 3:2 – ACTION[1:0]** BOD33 Action  
These bits are used to select the BOD33 action when the supply voltage crosses below the BOD33 threshold.  
These bits are loaded from NVM User Row at start-up.  
This field is not synchronized.

Value	Name	Description
0x0	NONE	No action
0x1	RESET	The BOD33 generates a reset
0x2	INT	The BOD33 generates an interrupt
0x3	BKUP	The BOD33 puts the device in battery backup sleep mode.

**Bit 1 – ENABLE** Enable  
This bit is loaded from NVM User Row at start-up.

Value	Description
0	BOD33 is disabled.

Value	Description
1	BOD33 is enabled.

## 19.7.6 Voltage Regulator System (VREG) Control

**Name:** VREG  
**Offset:** 0x18  
**Reset:** 0x00000002  
**Property:** PAC Write-Protection

Bit	31	30	29	28	27	26	25	24
						VSPER[2:0]		
Access						R/W	R/W	R/W
Reset						0	0	0
Bit	23	22	21	20	19	18	17	16
							VSEN	
Access							R/W	
Reset							0	
Bit	15	14	13	12	11	10	9	8
Access								
Reset								
Bit	7	6	5	4	3	2	1	0
	RUNBKUP					SEL	ENABLE	
Access	R/W					R/W	R/W	
Reset	0					0	1	

### Bits 26:24 – VSPER[2:0] Voltage Scaling Period

This bitfield defines the time between the voltage steps when the VDDCORE voltage scaling is enabled.

The time is  $(2^{VSPER}) * T$ , where T is an internal period (typ 250 ns).

### Bit 16 – VSEN Voltage Scaling Enable

Value	Description
0	The voltage scaling is disabled.
1	The voltage scaling is enabled.

### Bit 7 – RUNBKUP Run in Backup

This bit controls how the main voltage regulator behaves in backup sleep mode.

Value	Description
0	The main voltage regulator is halted during backup sleep mode.
1	The main voltage regulator is not stopped during backup sleep mode.

### Bit 2 – SEL Voltage Regulator Selection

This bit is loaded from NVM User Row at start-up. Refer to *NVM User Row Mapping* section for more details.

Value	Description
0	The main voltage regulator is a LDO voltage regulator.
1	The main voltage regulator is a buck converter.

### Bit 1 – ENABLE Must be set to 1.

## 19.7.7 Voltage References System (VREF) Control

**Name:** VREF  
**Offset:** 0x1C  
**Reset:** 0x00000000  
**Property:** PAC Write-Protection

Bit	31	30	29	28	27	26	25	24
Access								
Reset								
Bit	23	22	21	20	19	18	17	16
Access					SEL[3:0]			
Reset					R/W	R/W	R/W	R/W
					0	0	0	0
Bit	15	14	13	12	11	10	9	8
Access								
Reset								
Bit	7	6	5	4	3	2	1	0
Access	ONDEMAND	RUNSTDBY				VREFOE		
Reset	R/W	R/W				R/W		
	0	0				0		

### Bits 19:16 – SEL[3:0] Voltage Reference Selection

These bits select the Voltage Reference for the ADC/DAC.

Value	Name	Description
0x6	2V4	2.4V voltage reference typical value
0x7	2V5	2.5V voltage reference typical value
Others	-	Reserved

### Bit 7 – ONDEMAND On Demand Control

The On Demand operation mode allows to enable or disable the voltage reference depending on peripheral requests.

Value	Description
0	The voltage reference is always on, if enabled.
1	The voltage reference is enabled when a peripheral is requesting it. The voltage reference is disabled if no peripheral is requesting it.

### Bit 6 – RUNSTDBY Run In Standby

The bit controls how the voltage reference behaves during standby sleep mode.

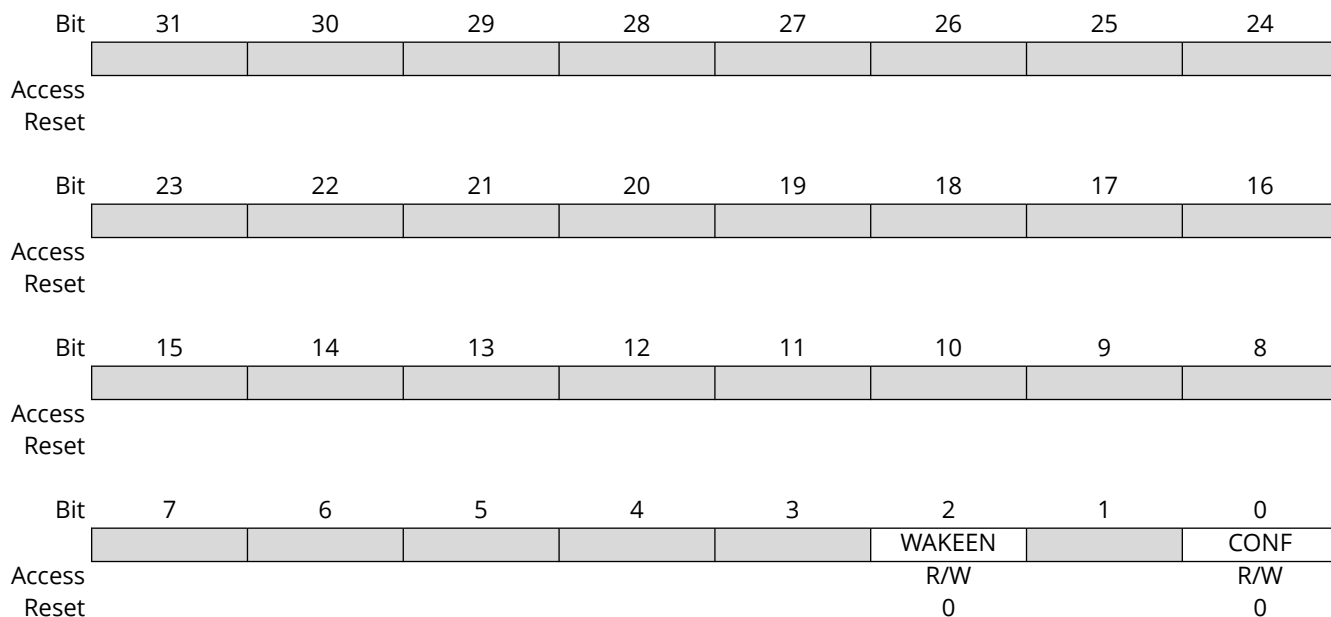
Value	Description
0	The voltage reference is halted during standby sleep mode.
1	The voltage reference is not stopped in standby sleep mode. If VREF.ONDEMAND=1, the voltage reference will be running when a peripheral is requesting it. If VREF.ONDEMAND=0, the voltage reference will always be running in standby sleep mode.

### Bit 2 – VREFOE Voltage Reference Output Enable

Value	Description
0	The Voltage Reference output (INTREF) is not available as an ADC input channel.
1	The Voltage Reference output (INTREF) is routed to an ADC input channel.

### 19.7.8 Battery Backup Power Switch (BBPS) Control

**Name:** BBPS  
**Offset:** 0x20  
**Reset:** 0x00000000  
**Property:** PAC Write-Protection



#### Bit 2 - WAKEEN Wake Enable

Value	Description
0	The device is not woken up when switched from battery backup power to Main Power.
1	The device is woken up when switched from battery backup power to Main Power.

#### Bit 0 - CONF Battery Backup Power Switch Configuration

Value	Name	Description
0x0	BOD33	The power switch is handled by the BOD33 according to the BOD33.ACTION bit field.
0x1	FORCED	In backup sleep mode, the backup domain is always supplied by Battery Backup Power.

### 19.7.9 Backup Output (BKOUT) Control

**Name:** BKOUT  
**Offset:** 0x24  
**Reset:** 0x00000000  
**Property:** PAC Write-Protection

Bit	31	30	29	28	27	26	25	24
							RTCTGLOUT1	RTCTGLOUT0
Access							R/W	R/W
Reset							0	0
Bit	23	22	21	20	19	18	17	16
							SETOUT1	SETOUT0
Access							W	W
Reset							0	0
Bit	15	14	13	12	11	10	9	8
							CLROUT1	CLROUT0
Access							W	W
Reset							0	0
Bit	7	6	5	4	3	2	1	0
							ENOUT1	ENOUT0
Access							R/W	R/W
Reset							0	0

#### Bits 24, 25 – RTCTGLOUT RTC Toggle Output pin x (OUTx)

Value	Description
0	The Output (OUTx) will not toggle on RTC event.
1	The Output (OUTx) will toggle on RTC event.

#### Bits 16, 17 – SETOUT Set Output pin x (OUTx)

Writing a '0' to a bit has no effect.  
 Writing a '1' to a bit will set the corresponding Output (OUTx).  
 Reading this bit returns '0'.

#### Bits 8, 9 – CLROUT Clear Output pin x (OUTx)

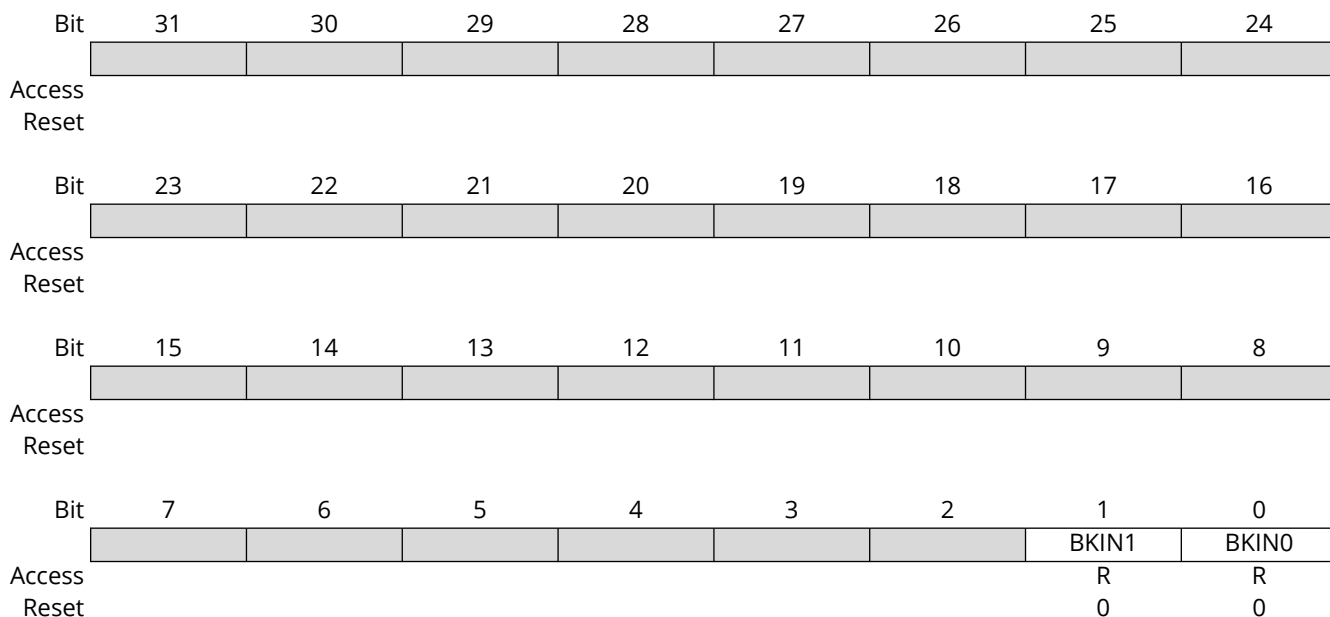
Writing a '0' to a bit has no effect.  
 Writing a '1' to a bit will clear the corresponding Output (OUTx).  
 Reading this bit returns '0'.

#### Bits 0, 1 – ENOUT Enable Output pin x (OUTx)

Value	Description
0	The Output (OUTx) is not enabled.
1	The Output (OUTx) is enabled and driven by the SUPC.

### 19.7.10 Backup Input (BKIN) Value

**Name:** BKIN  
**Offset:** 0x28  
**Reset:** 0x00000000  
**Property:** -



#### Bits 0, 1 – BKIN Input pin x Value (OUTx)

These bits are cleared when the corresponding I/O pin x (OUTx) detects a logical low level on the input pin or when the I/O is not enabled.

These bits are set when the corresponding I/O pin x (OUTx) detects a logical high level on the input pin when the I/O is enabled.

Value	Name	Description
BKIN0	OUT0	If BKOUT.ENOUT0 = 1, BKIN0 will give the input value of the OUT0 pin
BKIN1	OUT1	If BKOUT.ENOUT1 = 1, BKIN1 will give the input value of the OUT1 pin

## 20. Power Manager (PM)

### 20.1 Overview

The Power Manager (PM) controls the sleep modes and the power domain gating of the device.

Various sleep modes are provided in order to fit power consumption requirements. This enables the PM to stop unused modules in order to save power. In active mode, the CPU is executing application code. When the device enters a sleep mode, program execution is stopped and some modules and clock domains are automatically switched off by the PM according to the sleep mode. The application code decides which sleep mode to enter and when. Interrupts from enabled peripherals and all enabled reset sources can restore the device from a Sleep mode to Active mode.

The user manually controls which power domains will be turned on and off in Standby, Hibernate, and Backup Sleep modes.

In Backup and Hibernate modes, the PM allows retaining the state of the I/O lines, preventing I/O lines from toggling during wake-up.

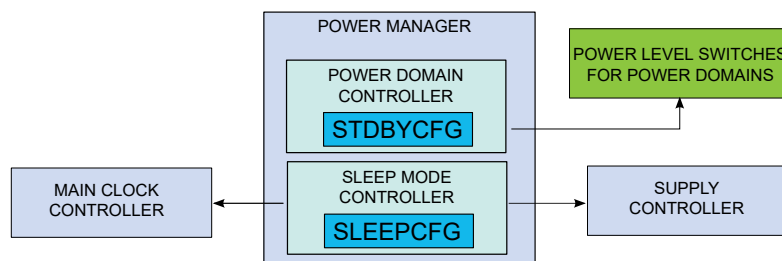
### 20.2 Features

The following are key features of the PM:

- Power management control
  - Sleep modes: Idle, Hibernate, Standby, Backup, and Off
  - SleepWalking available in Standby mode.
  - I/O lines retention in Backup mode

### 20.3 Block Diagram

Figure 20-1. PM Block Diagram



### 20.4 Peripheral Dependencies

<b>Peripheral Name</b>	PM – Power Manager
<b>Base Address</b>	0x4000_0400 (Peripheral Bus A)
<b>NVIC IRQ Index:Source</b>	0 : SLEEPDY
<b>MCLK APB Clock (1)</b>	CLK_PM_APB, Enabled, APBAMASK.PM
<b>GCLK Peripheral Channel Index:Clock Name</b>	n/a
<b>PAC Peripheral Identifier (PAC.WRCTRL)</b>	1
<b>Note:</b>	
1.	Clock Name, Default State, Mask Field.



### 20.4.1 Debug Operation

When the CPU is halted in Debug mode, the PM continues normal operation. If Standby mode is requested by the system while in Debug mode, the power domains are not turned off. As a consequence, power measurements while in Debug mode are not relevant.

If Hibernate mode or Backup mode is requested by the system while in Debug mode, the core domains are kept on, and the debug modules are kept running to allow the debugger to access internal registers. When exiting the Hibernate or Backup mode upon a reset condition, the core domains are reset except the debug logic, allowing users to keep using their current debug session.

If Off mode is requested while in Debug mode, the core domains are reset.

Hot plugging in Standby mode is supported.

Hot plugging in Hibernate or Backup mode or Off mode is not supported as the DSU module is not powered.

Cold plugging in Hibernate or Backup or Off mode is supported if the external reset duration is superior to the corresponding Sleep mode wakeup time, refer to the Chapter "Electrical characteristic".

Backup wakeup time is less than 200 us in a typical case. This value can be higher if voltage scaling in SUPC is enabled. Refers to the [SUPC](#) for additional information.

### 20.4.2 Register Access Protection

Registers with write access can be write-protected optionally by the [Peripheral Access Controller \(PAC\)](#).

PAC write protection is not available for the following registers:

- Interrupt Flag register ([INTFLAG](#))

Optional PAC write protection is denoted by the "PAC Write-Protection" property in each individual register description.

Write-protection does not apply to accesses through an external debugger.

## 20.5 Functional Description

### 20.5.1 Terminology

The following is a list of terms used to describe the Power Management features of this microcontroller.

#### 20.5.1.1 Power Domains

Leaving aside the supply domains, such as AVDD and VDD, the device is split into these power domains: PDCORESW, PDBACKUP, PDSYSRAM and PDBKUPRAM.

PDCORESW, PDSYSRAM and PDBKUPRAM are "switchable power domains". In Standby, Hibernate or Backup mode, these power domains can be turned OFF to save leakage consumption according to user configuration.

- PDCORESW: contains the CPU and all the peripherals, except those located in the backup power domain.
- PDBACKUP: contains the backup peripherals: OSC32KCTRL, SUPC, RSTC, RTC and the PM itself.
- PDSYSRAM: contains the system RAM. It can be partially or fully turned OFF in Standby or Hibernate mode according to user configuration.
- PDBKUPRAM: contains the backup RAM. It can be partially or fully turned OFF in Backup mode.

#### 20.5.1.2 Sleep Modes

The device can be set in a Sleep mode. In Sleep mode, the CPU is stopped and the peripherals are either active or idle, according to the Sleep mode depth:

- Idle mode: The CPU is stopped. Synchronous clocks are stopped except when requested. The logic is retained.
- Standby mode: The CPU is stopped as well as the peripherals. The logic is retained, and power domain gating can be used to fully or partially turn off the PDSYSRAM power domain.
- Hibernate mode: PDCORESW power domain is turned off. The backup power domain is kept powered to allow few features to run (RTC, 32 kHz clock sources, and wake-up from external pins). The PDSYSRAM power domain can be retained according to software configuration.
- Backup mode: Only the backup domain is kept powered to allow few features to run (RTC, 32 kHz clock sources, and wake-up from external pins). The PDBKUPRAM power domain can be retained according to software configuration.
- Off mode: The entire device is powered off.

## 20.5.2 Principle of Operation

In Active mode, all clock domains and power domains are active, allowing software execution and peripheral operation. The PM Sleep mode Controller allows to save power by choosing between different sleep modes depending on application requirements, see [20.5.3.3. Sleep Mode Controller](#).

The PM Power Domain Controller allows to reduce the power consumption in Standby mode even further.

## 20.5.3 Basic Operation

### 20.5.3.1 Initialization

After a Power-on Reset (POR), the PM is enabled, the device is in Active mode.

### 20.5.3.2 Enabling, Disabling and Resetting

The PM is always enabled and can not be reset.

### 20.5.3.3 Sleep Mode Controller

A Sleep mode is entered by executing the Wait For Interrupt instruction (WFI). The Sleep Mode bits in the Sleep Configuration register ([20.6.2. SLEEP\\_CFG.SLEEPMODE](#)) select the level of the Sleep mode.

**Note:** A small latency happens between the store instruction and actual writing of the [SLEEP\\_CFG.SLEEPMODE](#) register due to bridges. Software must ensure that the [SLEEP\\_CFG.SLEEPMODE](#) register reads the desired value before executing a WFI instruction.

**Note:** After power-up, the MAINVREG low power mode takes some time to stabilize. Once stabilized, the INTFLAG.SLEEP\_RDY bit is set. Before entering Standby, Hibernate or Backup mode, software must ensure that the INTFLAG.SLEEP\_RDY bit is set.

**Table 20-1.** Sleep Mode Entry and Exit Table

Mode	Mode Entry	Wake-Up Sources
IDLE	SLEEP_CFG.SLEEPMODE = IDLE	Synchronous <sup>(2)</sup> (APB, AHB), asynchronous <sup>(1)</sup>
STANDBY	SLEEP_CFG.SLEEPMODE = STANDBY	Synchronous <sup>(3)</sup> , asynchronous <sup>(1)</sup>
HIBERNATE	SLEEP_CFG.SLEEPMODE = HIBERNATE	Hibernate reset detected by the RSTC
BACKUP	SLEEP_CFG.SLEEPMODE = BACKUP	Backup reset detected by the RSTC
OFF	SLEEP_CFG.SLEEPMODE = OFF	External Reset

#### Notes:

1. Asynchronous: interrupt generated on generic clock, external clock, or external event.
2. Synchronous: interrupt generated on synchronous (APB or AHB) clock.
3. Synchronous interrupt only for peripherals configured to run in standby.

**Note:** The type of wake-up sources (synchronous or asynchronous) is given in each module interrupt section.

The sleep modes (Idle, Standby, Hibernate, Backup, and Off) and their effect on the clocks activity, the regulator and the NVM state are described in the table and the sections below. Refer to [20.5.3.5. Power Domain Controller](#) for the power domain gating effect.

**Table 20-2.** Sleep Mode Overview

Mode	Main clock	CPU	AHBx and APBx clock	GCLK clocks	Oscillators		Regulator	NVM
					ONDEMAND = 0	ONDEMAND = 1		
Active	Run	Run	Run	Run <sup>(1)</sup>	Run	Run if requested	MAINVREG	active
IDLE	Run	Stop	Stop <sup>(2)</sup>	Run <sup>(1)</sup>	Run	Run if requested	MAINVREG	active
STANDBY	Stop	Stop	Stop <sup>(2)</sup>	Stop <sup>(2)</sup>	Run if requested or RUNSTDBY=1	Run if requested	MAINVREG in low power mode	Ultra Low power
HIBERNATE	Stop	Stop	Stop	Stop	Stop	Stop	MAINVREG in low power mode	Ultra Low power+
BACKUP	Stop	Stop	Stop	Stop	Stop	Stop	Backup regulator (LPVREG)	OFF
OFF	Stop	Stop	Stop	OFF	OFF	OFF	OFF	OFF

**Notes:**

1. Running if requested by peripheral during SleepWalking.
2. Running during SleepWalking.

### 20.5.3.3.1 Idle Mode

Idle mode allows power optimization with the fastest wake-up time.

The CPU is stopped, and peripherals are still working. As in Active mode, the AHBx and APBx clocks for peripheral are still provided if requested. As the main clock source is still running, wake-up time is very fast.

- Entering Idle mode: The Idle mode is entered by executing the WFI instruction. Additionally, if the SLEEPONEXIT bit in the Cortex System Control register (SCR) is set, the Idle mode will be entered when the CPU exits the lowest priority ISR (Interrupt Service Routine, refer to the ARM Cortex documentation for details). This mechanism can be useful for applications that only require the processor to run when an interrupt occurs. Before entering the Idle mode, the user must select the Idle Sleep mode in the Sleep Configuration register (SLEEPCFG.SLEEPMODE = IDLE).
- Exiting Idle mode: The processor wakes the system up when it detects any non-masked interrupt with sufficient priority to cause exception entry. The system goes back to the Active mode. The CPU and affected modules are restarted.

GCLK clocks, regulators and RAM are not affected by the Idle mode and operate in normal mode.

### 20.5.3.3.2 Standby Mode

The Standby mode is the lowest power configuration while keeping the state of the logic and the content of the RAM.

In this mode, all clocks are stopped except those configured to be running sleepwalking tasks. The clocks can also be active on request or at all times, depending on their on-demand and run-in-standby settings. Either synchronous (CLK\_APBx or CLK\_AHBx) or generic (GCLK\_x) clocks or both can be involved in sleepwalking tasks. This is the case when for example the SERCOM RUNSTDBY bit is written to '1'.

- Entering Standby mode: This mode is entered by executing the WFI instruction after writing the Sleep Mode bit in the Sleep Configuration register ([20.6.2. SLEEPCFG.SLEEPMODE=STANDBY](#)). The SLEEPONEXIT feature is also available as in Idle mode.
- Exiting Standby mode: Any peripheral able to generate an asynchronous interrupt can wake up the system. For example, a peripheral running on a GCLK clock can trigger an interrupt. When the enabled asynchronous wake-up event occurs and the system is woken up, the device will either

execute the interrupt service routine or continue the normal program execution according to the Priority Mask Register (PRIMASK) configuration of the CPU.

Refer to the section [Power Domain Controller](#) for the RAM state.

The regulator operates in low-power mode by default and switches automatically to the normal mode in case of a sleepwalking task requiring more power. It returns automatically to low-power mode when the sleepwalking task is completed.

### 20.5.3.3.3 Hibernate and Backup Mode

Hibernate mode and Backup mode allow achieving the lowest power consumption aside from OFF. The device is entirely powered off except for the backup domain. All peripherals in backup domain are allowed to run, for example, the RTC can be clocked by a 32.768 kHz oscillator. All PM registers are retained except INTENCLR, INTENSET, INTFLAG, and SLEEPCFG registers.

- Entering Hibernate or Backup mode: This mode is entered by executing the WFI instruction after selecting the Hibernate or Backup mode by writing the Sleep Mode bits in the Sleep Configuration register (20.6.2. SLEEPCFG.SLEEPMODE=HIBERNATE or =BACKUP).
- Exiting Hibernate or Backup mode: is triggered when a Hibernate or Backup Reset is detected by the Reset Controller (RSTC).

**Note:** In Hibernate mode, the MAINVREG (in low-power mode) regulator is used to allow powering the PDRAM power domain which can be fully retained according to software configuration.

**Note:** In Backup mode, the backup regulator (LPVREG) is used, unless VREG.RUNBKUP = 1. When VREG.RUNBKUP is set, the Main regulator is used in backup mode. The PDBKUPRAM power domain can be fully retained according to software configuration.

Refer to the [20.5.3.5. Power Domain Controller](#) for the RAM state.

### 20.5.3.3.4 OFF Mode

In Off mode, the device is entirely powered-off.

- Entering Off mode: This mode is entered by selecting the Off mode in the Sleep Configuration register by writing the Sleep Mode bits (SLEEPCFG.SLEEPMODE=OFF), and subsequent execution of the WFI instruction.
- Exiting Off mode: This mode is left by pulling the  $\overline{\text{RESET}}$  pin low, or when a power Reset is done.

### 20.5.3.4 I/O Lines Retention in Hibernate or Backup Mode

When entering Hibernate or Backup mode, the PORT is powered off but the pin configuration is retained. When the device exits the Hibernate or Backup mode, the I/O line configuration can either be released or stretched, based on the I/O Retention bit in the Control A register (CTRLA.IORET).

- If IORET = 0 when exiting Hibernate or Backup mode, all the I/O lines configuration is released and driven by the reset value of the PORT.
- If the IORET = 1 when exiting Hibernate or Backup mode, the configuration of all the I/O lines is retained until the IORET bit is written to 0. It allows the I/O lines to be retained until the application has programmed the PORT.

### 20.5.3.5 Power Domain Controller

The Power Domain Controller provides several ways of how power domains are handled while the device is in standby, hibernate or backup mode:

- Standby mode: When entering Standby mode, the PDSYSRAM power domain can be either fully or partially retained or be fully off according to STDBYCFG.RAMCFG bits. When running sleepwalking task, PDSYSRAM power domain is active whatever the STDBYCFG.RAMCFG bits are.
- Hibernate mode: When entering Hibernate mode, the PDCORESW power domain is off. As in Standby mode, the PDSYSRAM power domain can be selectively turned ON or OFF by using the HIBCFG.RAMCFG bits. PDBKUPRAM power domain can be either fully or partially retained or be

fully off according to HIBCFG.BRAMCFG bits. If partial option is selected, only the lowest 4 KBytes section is retained

- Backup mode: When entering Backup mode, the PDCORESW and PDSYSRAM power domains are off. PDBACKUP is still active. As in Hibernate mode, PDBKUPRAM power domain can be either fully or partially retained or be fully off according to BKUPCFG.BRAMCFG bits.
- Off mode: When entering Off mode, all the power domains are off.

The table below illustrates the PDRAM state:

**Table 20-3.** Sleep Mode versus PDSYSRAM Power Domain State Overview

Sleep Mode	STDBYCFG.RAMCFG	HIBCFG.RAMCFG	Power Domain State		
			PDCORESW	PDBACKUP	PDSYSRAM
Active	N/A	N/A	active	active	active
Idle	N/A	N/A	active	active	active
Standby with sleepwalking	N/A	N/A	active	active	active
Standby - case 1	RET	N/A	active	active	retained
Standby - case 2	PARTIAL	N/A	active	active	32K retained
Standby - case 3	OFF	N/A	active	active	off
Hibernate - case 1	N/A	RET	off	active	retained
Hibernate - case 2	N/A	PARTIAL	off	active	32K retained
Hibernate - case 3	N/A	OFF	off	active	off
Backup	N/A	N/A	off	active	off
Off	N/A	N/A	off	off	off

The table below illustrates the PDBKUPRAM state:

**Table 20-4.** Sleep Mode versus PDBKUPRAM Power Domain State Overview

Sleep Mode	HIBCFG.BRAMCFG	BKUPCFG.BRAMCFG	Power Domain State		
			PDCORESW	PDBACKUP	PDBKUPRAM
Active	N/A	N/A	active	active	active
Idle	N/A	N/A	active	active	active
Standby	N/A	N/A	active	active	retained
Hibernate - case 1	RET	N/A	off	active	retained
Hibernate - case 2	PARTIAL	N/A	off	active	4KB retained
Hibernate - case 3	OFF	N/A	off	active	off
Backup	N/A	RET	off	active	retained
Backup	N/A	PARTIAL	off	active	4KB retained
Backup	N/A	OFF	off	active	off
Off	N/A	N/A	off	off	off

### 20.5.3.6 Regulators, RAMs, and NVM State in Sleep Mode

By default, in Standby mode and Backup mode, the RAMs, NVM, and regulators are automatically set in low-power mode in order to reduce the power consumption:

- The RAM is in low-power mode if the device is in Standby mode.
- Non-Volatile Memory - the NVM is automatically set in Low-Power mode in these conditions:

- When the device is in Standby mode and the NVM is not accessed. This behavior can be changed by software by configuring the SLEEPPRM bit group of the CTRLB register in the NVMCTRL peripheral.
- When the device is in Idle mode and the NVM is not accessed. This behavior can be changed by software by configuring the SLEEPPRM bit group of the CTRLB register in the NVMCTRL peripheral.
- Regulators: by default, in Standby mode, the PM analyzes the device activity to use either the main or the low-power voltage regulator to supply the VDDCORE.

GCLK clocks, regulators and RAM are not affected in Idle mode and will operate as normal.

**Table 20-5.** Regulators, RAMs, and NVM state in Sleep Mode

Sleep Mode	SRAM Mode	NVM	Regulators		
			VDDCORE		VDDBU
			main	ULP	
Active	normal	normal	on	on	on
Idle	auto <sup>(1)</sup>	on	on	on	on
Standby - case 1	normal	auto <sup>(1)</sup>	auto <sup>(2)</sup>	on	on
Standby - case 2	low power	low power	auto <sup>(2)</sup>	on	on
Standby - case 3	low power	low power	auto <sup>(2)</sup>	on	on
Standby - case 4	low power	low power	off	on	on
Backup	off	off	off	off	on
OFF	off	off	off	off	off

**Notes:**

1. auto: by default, NVM is in low-power mode if not accessed.
2. auto: by default, the main voltage regulator is on if GCLK, APBx, or AHBx clock is running during SleepWalking.

## 20.5.4 Advanced Features

### 20.5.4.1 SleepWalking

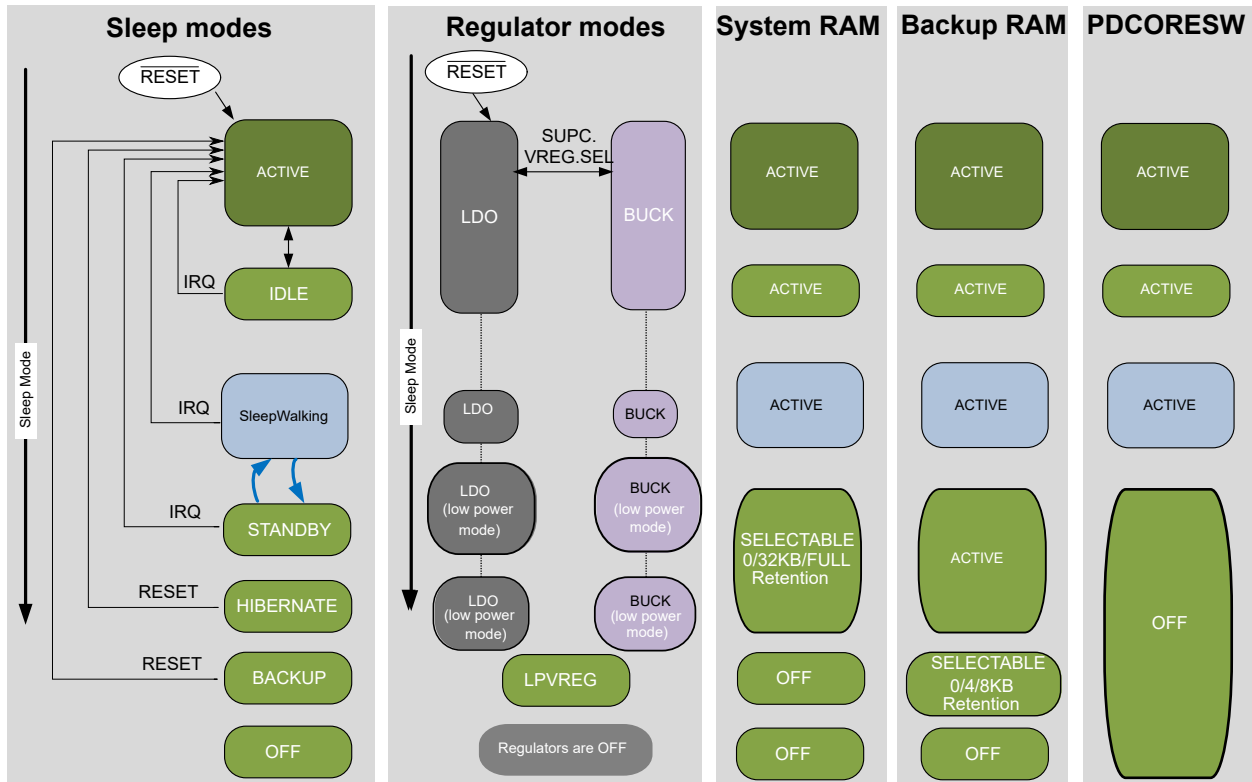
SleepWalking is the capability for a device to temporarily wake up clocks for a peripheral to perform a task without waking up the CPU from Standby mode. At the end of the sleepwalking task, the device can either be woken up by an interrupt (from a peripheral involved in SleepWalking) or enter again into Standby mode. In this device, SleepWalking is supported only on GCLK clocks by using the on-demand clock principle of the clock sources.

In Standby mode, when SleepWalking is ongoing:

- All the power domains are turned ON including PDRAM power domain.
- The MAINVREG regulator used to execute the sleepwalking task is the selected regulator used in active mode (LDO or Buck converter). Low-Power mode of the MAINVREG is not activated during sleepwalking.

These are illustrated in the figure below.

Figure 20-2. Operating Conditions and SleepWalking

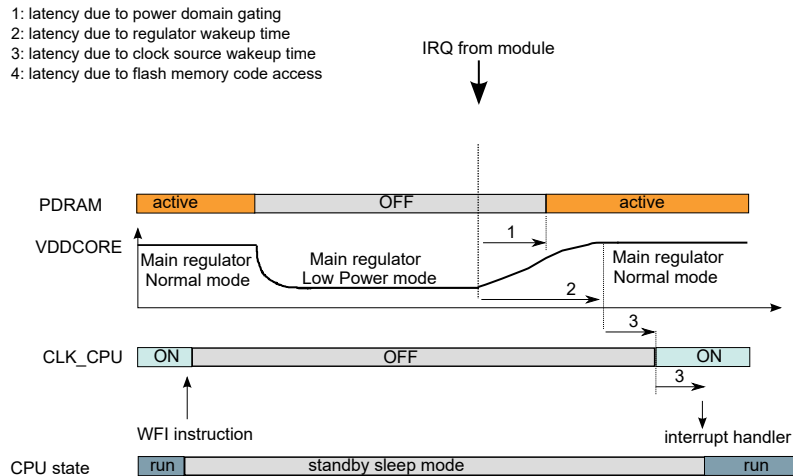


### 20.5.4.2 Wake-Up Time

As shown in the figure below, total wake-up time depends on:

- Latency due to Power Domain Gating:  
Usually, wake-up time is measured with the assumption that the power domains are already in active state. When using Power Domain Gating, changing a power domain from OFF to active state will take a certain time, refer to Electrical Characteristics. If all power domains were already in active state in standby sleep mode, this latency is zero.
- Latency due to Regulator effect:  
As example, if the device is in standby sleep mode using the main voltage regulator (MAINVREG) in low power mode, the voltage level is lower than the one used in active mode. When the device wakes up, it takes a certain amount of time for the main regulator to transition to the voltage level corresponding to Active mode, causing additional wake-up time.
- Latency due to the CPU clock source wake-up time.
- Latency due to the NVM memory access.  
**Note:** NVM and MAINVREG latencies can be reduced by setting the Fast Wake-Up bits in the Standby Configuration register (STDBYCFG.FASTWKUP).

**Figure 20-3. Total Wake-up Time from Standby Sleep Mode**



### 20.5.5 Interrupts

The peripheral has the following interrupt sources:

- Sleep Mode Entry Ready (SLEEPREADY): Indicates that the device is ready to enter Standby, Hibernate, or Backup mode.  
This interrupt is a synchronous wake-up source.

Each interrupt source has an interrupt flag associated with it. The interrupt flag in the Interrupt Flag Status and Clear (INTFLAG) register is set when the interrupt condition occurs. Each interrupt can be individually enabled by writing a '1' to the corresponding bit in the Interrupt Enable Set (INTENSET) register, and disabled by writing a '1' to the corresponding bit in the Interrupt Enable Clear (INTENCLR) register.

An interrupt request is generated when the interrupt flag is set and the corresponding interrupt is enabled. The interrupt request remains active until the interrupt flag is cleared, the interrupt is disabled or the peripheral is reset.

An interrupt flag is cleared by writing a '1' to the corresponding bit in the INTFLAG register. Each peripheral can have one interrupt request line per interrupt source or one common interrupt request line for all the interrupt sources. If the peripheral has one common interrupt request line for all the interrupt sources, the user must read the INTFLAG register to determine which interrupt condition is present.

### 20.5.6 Sleep Mode Operation

The Power Manager is always active.

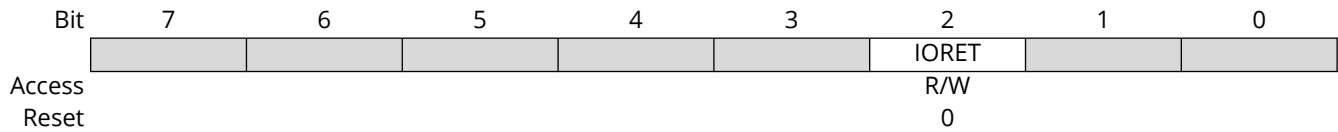


## 20.6 Register Summary

Offset	Name	Bit Pos.	7	6	5	4	3	2	1	0
0x00	<a href="#">CTRLA</a>	7:0						IORET		
0x01	<a href="#">SLEEPCFG</a>	7:0						SLEEPMODE[2:0]		
0x02	Reserved									
...										
0x03										
0x04	<a href="#">INTENCLR</a>	7:0								SLEEPRDY
0x05	<a href="#">INTENSET</a>	7:0								SLEEPRDY
0x06	<a href="#">INTFLAG</a>	7:0								SLEEPRDY
0x07	Reserved									
0x08	<a href="#">STDBYCFG</a>	7:0			FASTWKUP[1:0]				RAMCFG[1:0]	
0x09	<a href="#">HIBCFG</a>	7:0					BRAMCFG[1:0]		RAMCFG[1:0]	
0x0A	<a href="#">BKUPCFG</a>	7:0							BRAMCFG[1:0]	
0x0B	Reserved									
...										
0x11										
0x12	<a href="#">PWSAKDLY</a>	7:0	IGNACK				DLYVAL[6:0]			

## 20.6.1 Control A

**Name:** CTRLA  
**Offset:** 0x00  
**Reset:** 0x00  
**Property:** PAC Write-Protection



### Bit 2 – IORET I/O Retention

**Note:** This bit is not reset by a hibernate or backup reset. When the IORET feature is used, the debugger access to the chip will not be allowed until the IORET bit is cleared after waking up from hibernate or backup sleep. When the IORET is set in active mode, the PORT can still be controlled by peripherals and the PORT registers. It is only when the device wakes up from hibernate or backup sleep mode that the IORET= 1 will prevent the PORT from being controlled by the peripherals or PORT registers. POR and BOD33 resets can clear the IORET bit.

Value	Description
0	After waking up from Hibernate or Backup mode, I/O lines are not held.
1	After waking up from Hibernate or Backup mode, I/O lines are held until IORET is written to 0.

## 20.6.2 Sleep Configuration

**Name:** SLEEPCFG  
**Offset:** 0x01  
**Reset:** 0x02  
**Property:** PAC Write-Protection

Bit	7	6	5	4	3	2	1	0	
							SLEEPMODE[2:0]		
Access						R/W	R/W	R/W	
Reset						0	0	0	

### Bits 2:0 – SLEEPMODE[2:0] Sleep Mode

**Note:** A small latency happens between the store instruction and actual writing of the SLEEPCFG register due to bridges. Software has to make sure the SLEEPCFG register reads the wanted value before executing WFI instruction.

Value	Name	Definition
0x0	Reserved	-
0x1	Reserved	-
0x2	IDLE	CPU, AHBx, and APBx clocks are OFF
0x3	Reserved	Reserved
0x4	STANDBY	All Clocks are OFF
0x5	HIBERNATE	Backup domain is ON as well as some PDRAMs
0x6	BACKUP	Only Backup domain is powered ON
0x7	OFF	All power domains are powered OFF

### 20.6.3 Interrupt Enable Clear

**Name:** INTENCLR  
**Offset:** 0x04  
**Reset:** 0x00  
**Property:** PAC Write-Protection

This register allows the user to disable an interrupt without doing a read-modify-write operation. Changes in this register will also be reflected in the Interrupt Enable Set (INTENSET) register.

Bit	7	6	5	4	3	2	1	0
								SLEEPRDY
Access								W
Reset								0

#### Bit 0 – SLEEPRDY Sleep Mode Entry Ready Interrupt Enable

Writing a '0' to this bit has no effect.

Writing a '1' to this bit will clear the Sleep Mode Entry Ready Interrupt Enable bit and the corresponding interrupt request.

Value	Description
0	The Sleep Mode Entry Ready interrupt is disabled.
1	The Sleep Mode Entry Ready interrupt is enabled and will generate an interrupt request when the Sleep Mode Entry Ready Interrupt Flag is set.

## 20.6.4 Interrupt Enable Set

**Name:** INTENSET  
**Offset:** 0x05  
**Reset:** 0x00  
**Property:** PAC Write-Protection

This register allows the user to enable an interrupt without doing a read-modify-write operation. Changes in this register will also be reflected in the Interrupt Enable Clear (INTENCLR) register.

Bit	7	6	5	4	3	2	1	0
								SLEEPRDY
Access								R/W
Reset								0

### Bit 0 – SLEEPRDY Sleep Mode Entry Ready Interrupt Enable

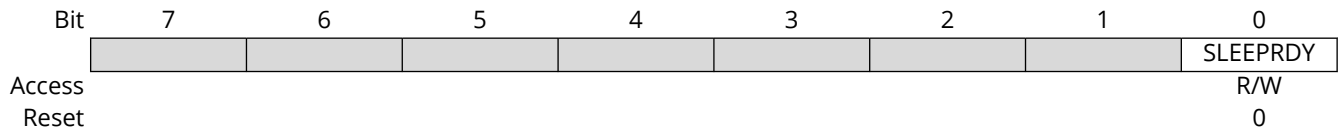
Writing a '0' to this bit has no effect.

Writing a '1' to this bit will set the Sleep Mode Entry Ready Interrupt Enable bit and enable the Sleep Mode Entry Ready interrupt.

Value	Description
0	The Sleep Mode Entry Ready interrupt is disabled.
1	The Sleep Mode Entry Ready interrupt is enabled.

## 20.6.5 Interrupt Flag Status and Clear

**Name:** INTFLAG  
**Offset:** 0x06  
**Reset:** 0x00  
**Property:** -



### Bit 0 – SLEEPRDY Sleep Mode Entry Ready

This flag is set when the main very low power mode is ready and will generate an interrupt if [INTENCLR/INTENSET](#).SLEEPRDY is '1'. See [this Note](#) for details.

Writing a '0' to this bit has no effect.

Writing a '1' to this bit clears the Performance Ready interrupt flag.

## 20.6.6 Hibernate Configuration

**Name:** HIBCFG  
**Offset:** 0x09  
**Reset:** 0x00  
**Property:** PAC Write-Protection

Bit	7	6	5	4	3	2	1	0
					BRAMCFG[1:0]		RAMCFG[1:0]	
Access					R/W	R/W	R/W	R/W
Reset					0	0	0	0

### Bits 3:2 – BRAMCFG[1:0] Backup RAM Configuration

Value	Name	Description
0x0	RET	In hibernate mode, all the backup RAM is retained.
0x1	PARTIAL	In hibernate mode, only the first 4Kbytes of the backup RAM is retained.
0x2	OFF	In hibernate mode, all the backup RAM is turned OFF.
0x3	Reserved	Reserved.

### Bits 1:0 – RAMCFG[1:0] RAM Configuration

Value	Name	Description
0x0	RET	In hibernate mode, all the system RAM is retained.
0x1	PARTIAL	In hibernate mode, only the first 32Kbytes of the system RAM is retained.
0x2	OFF	In hibernate mode, all the system RAM is turned OFF.
0x3	Reserved	Reserved.

## 20.6.7 Standby Configuration

**Name:** STDBYCFG  
**Offset:** 0x08  
**Reset:** 0x00  
**Property:** PAC Write-Protection

Bit	7	6	5	4	3	2	1	0
			FASTWKUP[1:0]				RAMCFG[1:0]	
Access			R/W	R/W			R/W	R/W
Reset			0	0			0	0

### Bits 5:4 – FASTWKUP[1:0] Fast Wake-up

Value	Name	Description
0x0	NO	Fast Wake-up is disabled.
0x1	NVM	Fast Wake-up is enabled on NVM.
0x2	MAINVREG	Fast Wake-up is enabled on the main voltage regulator (MAINVREG).
0x3	BOTH	Fast Wake-up is enabled on both NVM and MAINVREG.

### Bits 1:0 – RAMCFG[1:0] RAM Configuration

Value	Name	Description
0x0	RET	In standby mode, all the system RAM is retained.
0x1	PARTIAL	In standby mode, only the first 32Kbytes of the system RAM is retained.
0x2	OFF	In standby mode, all the system RAM is turned OFF.
0x3	Reserved	Reserved.



## 20.6.8 Backup Configuration

**Name:** BKUPCFG  
**Offset:** 0x0A  
**Reset:** 0x00  
**Property:** PAC Write-Protection

Bit	7	6	5	4	3	2	1	0
							BRAMCFG[1:0]	
Access							R/W	R/W
Reset							0	0

### Bits 1:0 – BRAMCFG[1:0] Backup RAM Configuration

Value	Name	Description
0x0	RET	In backup mode, all the backup RAM is retained.
0x1	PARTIAL	In backup mode, only the first 4Kbytes of the backup RAM is retained.
0x2	OFF	In backup mode, all the backup RAM is turned OFF.
0x3	Reserved	Reserved.

## 20.6.9 Global Status

**Name:** PWSAKDLY  
**Offset:** 0x12  
**Reset:** 0x00  
**Property:** -

Bit	7	6	5	4	3	2	1	0
	IGNACK	DLYVAL[6:0]						
Access	R	R	R	R	R	R	R	R
Reset	0	0	0	0	0	0	0	0

### Bit 7 - IGNACK Ignore Acknowledge signal

Value	Description
0	Power Switch acknowledge signal is taken into account when entering/exiting retention mode. According to the DLYVAL field, a supplementary delay is also added (from 0 to 127 digital ring oscillator period).
1	Power Switch acknowledge signal is ignored when entering/exiting retention mode, and is replaced by a overflow counter signal clocked on internal digital ring oscillator. The overflow counter is programmable by using the DLYVAL field.

### Bits 6:0 - DLYVAL[6:0] Delay value

Value of the counter overflow. See the IGNACK bit description to get more details.

## 21. Reset Controller (RSTC)

### 21.1 Overview

The Reset Controller (RSTC) manages the reset of the microcontroller. It issues a microcontroller reset, sets the device to its initial state and allows the reset source to be identified by software.

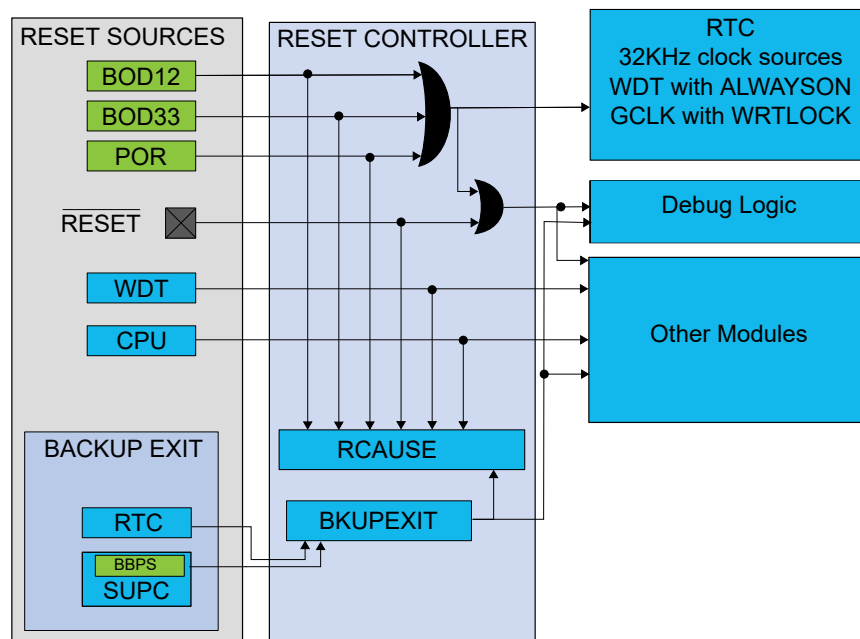
### 21.2 Features

The following are key features of the RSTC:

- Reset the microcontroller and set it to an initial state according to the reset source
- Reset cause register for reading the reset source from the application code
- Multiple reset sources
  - Power supply reset sources: POR, BOD12, BOD33
  - User reset sources: External reset ( $\overline{\text{RESET}}$ ), Watchdog reset, and System Reset Request
  - Backup exit sources: Real-Time Counter (RTC) and Battery Backup Power Switch (BBPS)

### 21.3 Block Diagram

Figure 21-1. Reset System



### 21.4 Signal Description

Signal Name	Type	Description
RESET	Digital input	External reset pin

One signal can be mapped on several pins.

### 21.5 Peripheral Dependencies

Peripheral Name	RSTC – Reset Controller
Base Address	0x4000_0C00 (Peripheral Bus A)
MCLK APB Clock (1)	CLK_RSTC_APB, Enabled, APBAMASK.RSTC

<b>GCLK Peripheral Channel Index:Clock Name</b>	n/a
<b>PAC Peripheral Identifier (PAC.WRCTRL)</b>	3
<b>Note:</b>	
1. Clock Name, Default State, Mask Field.	

### 21.5.1 Power Management

The Reset Controller module is always on.

### 21.5.2 Debug Operation

When the CPU is halted in debug mode, the RSTC continues normal operation.

### 21.5.3 Register Access Protection

All registers with write access can be optionally write-protected by the [Peripheral Access Controller \(PAC\)](#).

**Note:** Optional write protection is indicated by the "PAC Write Protection" property in the register description.

Write protection does not apply for accesses through an external debugger.

## 21.6 Functional Description

### 21.6.1 Principle of Operation

The Reset Controller collects the various Reset sources and generates Reset for the device.

### 21.6.2 Basic Operation

#### 21.6.2.1 Initialization

After a power-on Reset, the RSTC is enabled and the Reset Cause (RCAUSE) register indicates the POR source.

#### 21.6.2.2 Enabling, Disabling, and Resetting

The RSTC module is always enabled.

#### 21.6.2.3 Reset Causes and Effects

The latest Reset cause is available in RCAUSE register, and can be read during the application boot sequence that followed the reset in order to determine proper action.

These are the groups of Reset sources:

- **Power Supply Reset:** Resets caused by an electrical issue. It covers POR and BODs Resets.
- **User Reset:** Resets caused by the application. It covers external Resets, system Reset requests and watchdog Resets.
- **Backup Reset:** Resets caused by a Backup Mode exit condition.

The following table lists the parts of the device that are reset, depending on the Reset type.

**Table 21-1.** Effects of the Different Reset Causes

	Power Supply Reset	User Reset	
	POR, BOD33, BOD12	External Reset	WDT Reset, System Reset Request, NVM Reset
RTC, OSC32KCTRL, RSTC	Reset	-	-
GCLK with WRTLOCK	Reset	-	-
Debug logic	Reset	Reset	-
Others	Reset	Reset	Reset

The external Reset is generated when pulling the  $\overline{\text{RESET}}$  pin low.

The POR, BOD12, and BOD33 Reset sources are generated by their corresponding module in the [Supply Controller Interface \(SUPC\)](#).

The WDT Reset is generated by the Watchdog Timer.

The System Reset Request is a Reset generated by the CPU when asserting the SYSRESETREQ bit located in the Reset Control register of the CPU (for details refer to the ARM® Cortex™ Technical Reference Manual on <http://www.arm.com>).

The NVM Reset is a Reset generated by the NVMCTRL when for example a BKSWRST command is performed (for details refer to NVMCTRL chapter).

From Backup Mode, the chip can be waken-up upon these conditions:

- **Battery Backup Power Switch (BBPS):** generated by the SUPC controller when the 3.3V VDD is restored
- **Real-Time Counter interrupt:** For details refer to the applicable INTFLAG register in the RTC for details

If one of these conditions is triggered in Backup Mode, the RCAUSE.BACKUP bit is set and the Backup Exit Register (BKUPEXIT) is updated.

**Note:** Refer to the [Power Supply DC Electrical Specifications table](#) of the [Electrical Specifications](#) chapter.

### 21.6.3 Sleep Mode Operation

The RSTC module is active in all sleep modes.

## 21.7 Register Summary

Offset	Name	Bit Pos.	7	6	5	4	3	2	1	0
0x00	<a href="#">RCAUSE</a>	7:0	BACKUP	SYST	WDT	EXT	NVM	BOD33	BOD12	POR
0x01	Reserved									
0x02	<a href="#">BKUPEXIT</a>	7:0	HIB					BBPS	RTC	

## 21.7.1 Reset Cause

**Name:** RCAUSE  
**Offset:** 0x00  
**Property:** -

When a Reset occurs, the bit corresponding to the Reset source is set to '1' and all other bits are written to '0'.

Bit	7	6	5	4	3	2	1	0
	BACKUP	SYST	WDT	EXT	NVM	BOD33	BOD12	POR
Access	R	R	R	R	R	R	R	R
Reset	x	x	x	x	x	x	x	x

### Bit 7 - BACKUP Backup Reset

This bit is set if either a Backup or Hibernate Reset has occurred. Refer to BKUPEXIT register to identify the source of the Backup Reset.

### Bit 6 - SYST System Reset Request

This bit is set if a System Reset Request has occurred. Refer to the Cortex processor documentation for more details.

### Bit 5 - WDT Watchdog Reset

This bit is set if a Watchdog Timer Reset has occurred.

### Bit 4 - EXT External Reset

This bit is set if an external Reset has occurred.

### Bit 3 - NVM NVM Reset

This bit is set if an NVM Reset has occurred.

### Bit 2 - BOD33 Brown Out 33 Detector Reset

This bit is set if a BOD33 Reset has occurred.

### Bit 1 - BOD12 Brown Out 12 Detector Reset

This bit is set if a BOD12 Reset has occurred.

### Bit 0 - POR Power On Reset

This bit is set if a POR has occurred.

## 21.7.2 Backup Exit Source

**Name:** BKUPEXIT  
**Offset:** 0x02  
**Property:** -

When either a Hibernate or a Backup Reset occurs, the bit corresponding to the exit condition is set to '1', the other bits are written to '0'.

In some specific cases, the RTC and BBPS bits can be set together, i.e., when the device leaves the battery Backup Mode caused by a BBPS condition, and a RTC event was generated during the Battery Backup Mode period.

Bit	7	6	5	4	3	2	1	0
	HIB					BBPS	RTC	
Access	R					R	R	
Reset	x					x	x	

### Bit 7 – HIB Hibernate

This bit is set if an Hibernate reset occurs. This bit is zero if a backup reset occurs.

### Bit 2 – BBPS Battery Backup Power Switch

This bit is set if the Battery Backup Power Switch of the [Supply Controller](#) changes back from battery mode to main power mode.

### Bit 1 – RTC Real Timer Counter Interrupt

This bit is set if an [RTC](#) interrupt flag is set in Backup Mode.



## 22. Watchdog Timer (WDT)

### 22.1 Overview

The Watchdog Timer (WDT) is a system function for monitoring correct program operation. It makes it possible to recover from error situations such as runaway or deadlocked code. The WDT is configured to a predefined time-out period, and is constantly running when enabled. If the WDT is not cleared within the time-out period, it will issue a system reset. An early-warning interrupt is available to indicate an upcoming watchdog time-out condition.

The window mode makes it possible to define a time slot (or window) inside the total time-out period during which the WDT must be cleared. If the WDT is cleared outside this window, either too early or too late, a system reset will be issued. Compared to the normal mode, this can also catch situations where a code error causes the WDT to be cleared too frequently.

When enabled, the WDT will run in Active, Idle and Standby modes. It is asynchronous and runs from a CPU-independent clock source (OSCULP32K). The WDT will continue operation and issue a system reset or interrupt even if the main clocks fail.

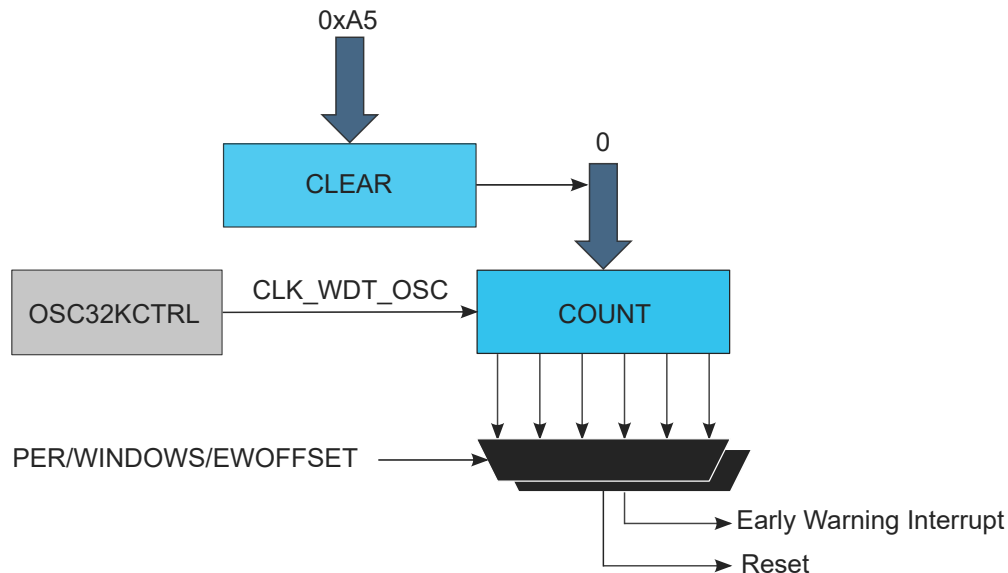
### 22.2 Features

The following are key features of the WDT:

- Issues a system reset if the Watchdog Timer is not cleared before its time-out period
- Early Warning interrupt generation
- Asynchronous operation from dedicated oscillator
- Two types of operation:
  - Normal mode
  - Window mode
- Selectable time-out periods
  - From 8 cycles to 16,384 cycles in Normal mode
  - From 16 cycles to 32,768 cycles in Window mode
- Always-On capability

## 22.3 Block Diagram

Figure 22-1. WDT Block Diagram



## 22.4 Peripheral Dependencies

<b>Peripheral Name</b>	WDT - Watchdog Timer
<b>Base Address</b>	0x4000_2000 (Peripheral Bus A)
<b>NVIC IRQ Index:Source</b>	10 : EW
<b>MCLK APB Clock (1)</b>	CLK_WDT_APB, Enabled, APBAMASK.WDT
<b>GCLK Peripheral Channel Index:Clock Name</b>	n/a
<b>PAC Peripheral Peripheral Identifier (PAC.WRCTRL)</b>	8
<b>Note:</b>	
1.	Clock Name, Default State, Mask Field.

### 22.4.1 Power Management

The WDT can continue to operate in any sleep modes where the selected source clock is running. The WDT interrupts can be used to wake up the device from sleep modes. The events can trigger other operations in the system without exiting sleep modes.

### 22.4.2 Clocks

The WDT bus clock (CLK\_WDT\_APB) can be enabled and disabled (masked) in the [Main Clock module \(MCLK\)](#).

A 1.024 kHz clock (CLK\_WDT\_OSC) is used to clock the WDT internal counter from the internal [Ultra Low-Power Oscillator \(OSCULP32K\)](#).

Due to ultra low-power design, the oscillator is not very accurate, therefore the exact time-out period may vary from device-to-device. This variation must be considered when designing software that uses the WDT to ensure that the time-out periods used are valid for all devices.

The counter clock CLK\_WDT\_OSC is asynchronous to the bus clock (CLK\_WDT\_APB). Due to this asynchronicity, writing to certain registers will require synchronization between the clock domains. Refer to [22.5.5. Synchronization](#) for further details.

### 22.4.3 Interrupts

The interrupt request line is connected to the [interrupt controller](#). Using the WDT interrupt(s) requires the interrupt controller to be configured first.

### 22.4.4 Debug Operation

When the CPU is halted in debug mode the WDT will halt normal operation.

### 22.4.5 Register Access Protection

Registers with write access can be write-protected optionally by the [Peripheral Access Controller \(PAC\)](#).

PAC write protection is not available for the following registers:

- Interrupt Flag register ([INTFLAG](#))

Optional PAC write protection is denoted by the "PAC Write-Protection" property in each individual register description.

Write-protection does not apply to accesses through an external debugger.

## 22.5 Functional Description

### 22.5.1 Principle of Operation

The Watchdog Timer (WDT) is a system for monitoring correct program operation, making it possible to recover from error situations such as runaway code, by issuing a Reset. When enabled, the WDT is a constantly running timer that is configured to a predefined time-out period. Before the end of the time-out period, the WDT should be set back, or else, a system Reset is issued.

The WDT has two modes of operation, Normal mode and Window mode. Both modes offer the option of Early Warning interrupt generation. The description for each of the basic modes is given below. The settings in the Control A register (CTRLA) and the Interrupt Enable register (handled by INTENCLR/INTENSET) determine the mode of operation:

**Table 22-1.** WDT Operating Modes

CTRLA.ENABLE	CTRLA.WEN	Interrupt Enable	Mode
0	x	x	Stopped
1	0	0	Normal mode
1	0	1	Normal mode with Early Warning interrupt
1	1	0	Window mode
1	1	1	Window mode with Early Warning interrupt

### 22.5.2 Basic Operation

#### 22.5.2.1 Initialization

The following bits are enable-protected, meaning that they can only be written when the WDT is disabled (CTRLA.ENABLE=0):

- Control A register (CTRLA), except the Enable bit (CTRLA.ENABLE) and Always-On bit (CTRLA.ALWAYSON)
- Configuration register (CONFIG)
- Early Warning Interrupt Control register (EWCTRL)

Enable-protected bits in the CTRLA register can be written at the same time as CTRLA.ENABLE is written to '1', but not at the same time as CTRLA.ENABLE is written to '0'.

The WDT can be configured only while the WDT is disabled. The WDT is configured by defining the required Time-Out Period bits in the Configuration register (CONFIG.PER). If Window mode operation

is desired, the Window Enable bit in the Control A register must be set (CTRLA.WEN=1) and the Window Period bits in the Configuration register (CONFIG.WINDOW) must be defined.

Enable-protection is denoted by the "Enable-Protected" property in the register description.

### 22.5.2.2 Configurable Reset Values

After a Power-on Reset, some registers will be loaded with initial values from the [NVM User Row](#).

This includes the following bits and bit groups:

- Enable bit in the Control A register, CTRLA.ENABLE
- Always-On bit in the Control A register, CTRLA.ALWAYSON
- Watchdog Timer Windows Mode Enable bit in the Control A register, CTRLA.WEN
- Watchdog Timer Windows Mode Time-Out Period bits in the Configuration register, CONFIG.WINDOW
- Time-Out Period bits in the Configuration register, CONFIG.PER
- Early Warning Interrupt Time Offset bits in the Early Warning Interrupt Control register, EWCTRL.EWOFFSET

### 22.5.2.3 Enabling, Disabling, and Resetting

The WDT is enabled by writing a '1' to the Enable bit in the Control A register (CTRLA.ENABLE). The WDT is disabled by writing a '0' to CTRLA.ENABLE.

The WDT can be disabled only if the Always-On bit in the Control A register (CTRLA.ALWAYSON) is '0'.

### 22.5.2.4 Normal Mode

In Normal mode operation, the length of a time-out period is configured in CONFIG.PER. The WDT is enabled by writing a '1' to the Enable bit in the Control A register (CTRLA.ENABLE). Once enabled, the WDT will issue a system reset if a time-out occurs. This can be prevented by clearing the WDT at any time during the time-out period.

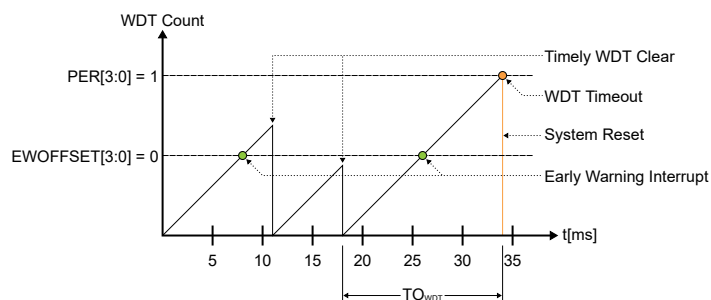
The WDT is cleared and a new WDT time-out period is started by writing 0xA5 to the Clear register (CLEAR). Writing any other value than 0xA5 to CLEAR will issue an immediate system reset.

There are 12 possible WDT time-out ( $TO_{WDT}$ ) periods, selectable from 8ms to 16s.

By default, the early warning interrupt is disabled. If it is desired, the Early Warning Interrupt Enable bit in the Interrupt Enable register (INTENSET.EW) must be written to '1'. The Early Warning Interrupt is disabled again by writing a '1' to the Early Warning Interrupt bit in the Interrupt Enable Clear register (INTENCLR.EW).

If the Early Warning Interrupt is enabled, an interrupt is generated prior to a WDT time-out condition. In Normal mode, the Early Warning Offset bits in the Early Warning Interrupt Control register, EWCTRL.EWOFFSET, define the time when the early warning interrupt occurs. The Normal mode operation is illustrated in the figure Normal-Mode Operation.

**Figure 22-2.** Normal-Mode Operation



### 22.5.2.5 Window Mode

In Window mode operation, the WDT uses two different time specifications: the WDT can only be cleared by writing 0xA5 to the CLEAR register *after* the closed window time-out period ( $TO_{WDTW}$ ), during the subsequent Normal time-out period ( $TO_{WDT}$ ). If the WDT is cleared before the time window opens (before  $TO_{WDTW}$  is over), the WDT will issue a system reset.

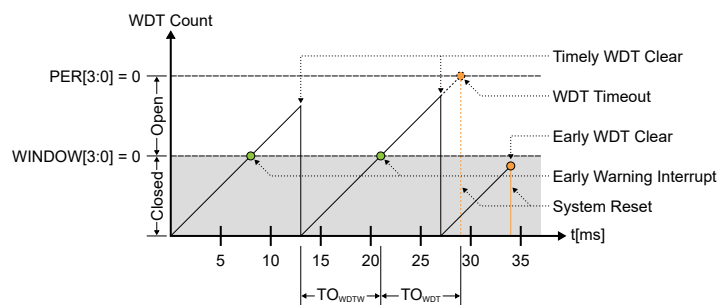
Both parameters  $TO_{WDTW}$  and  $TO_{WDT}$  are periods in a range from 8ms to 16s, so the total duration of the WDT time-out period is the sum of the two parameters.

The closed window period is defined by the Window Period bits in the Configuration register (CONFIG.WINDOW), and the open window period is defined by the Period bits in the Configuration register (CONFIG.PER).

By default, the Early Warning interrupt is disabled. If it is desired, the Early Warning Interrupt Enable bit in the Interrupt Enable register (INTENSET.EW) must be written to '1'. The Early Warning Interrupt is disabled again by writing a '1' to the Early Warning Interrupt bit in the Interrupt Enable Clear (INTENCLR.EW) register.

If the Early Warning interrupt is enabled in Window mode, the interrupt is generated at the start of the open window period, i.e. after  $TO_{WDTW}$ . The Window mode operation is illustrated in figure Window-Mode Operation.

**Figure 22-3.** Window-Mode Operation



### 22.5.3 Interrupts

The WDT has the following interrupt source:

- Early Warning (EW): Indicates that the counter is approaching the time-out condition.
  - This interrupt is an asynchronous wake-up source.

Each interrupt source has an interrupt flag associated with it. The interrupt flag in the Interrupt Flag Status and Clear (INTFLAG) register is set when the interrupt condition occurs.

Each interrupt can be individually enabled by writing a '1' to the corresponding bit in the Interrupt Enable Set (INTENSET) register, and disabled by writing a '1' to the corresponding bit in the Interrupt Enable Clear (INTENCLR) register. The status of enabled interrupts can be read from either INTENSET or INTENCLR.

An interrupt request is generated when the interrupt flag is set and the corresponding interrupt is enabled. The interrupt request remains active until the interrupt flag is cleared, the interrupt is disabled, or the WDT is reset. See the 22.6.6. INTFLAG register description for details on how to clear interrupt flags. All interrupt requests from the peripheral are ORed together on system level to generate one combined interrupt request to the NVIC. The user must read the INTFLAG register to determine which interrupt condition is present.

**Note:** Interrupts must be globally enabled for interrupt requests to be generated.

## 22.5.4 Sleep Mode Operation

The WDT will continue to operate in any sleep mode where the source clock is active except backup mode. The WDT interrupts can be used to wake up the device from a sleep mode. An interrupt request will be generated after the wake-up if the Interrupt Controller is configured accordingly. Otherwise the CPU will wake up directly, without triggering an interrupt. In this case, the CPU will continue executing from the instruction following the entry into sleep.

## 22.5.5 Synchronization

Due to asynchronicity between the main clock domain and the peripheral clock domains, some registers need to be synchronized when written or read.

The following registers are synchronized when written:

- Enable bit in Control A register ([CTRLA.ENABLE](#))
- Window Enable bit in Control A register ([CTRLA.WEN](#))
- Always-On bit in control Control A ([CTRLA.ALWAYSON](#))

Required write synchronization is denoted by the "Write-Synchronized" property in the register description.

Required read synchronization is denoted by the "Read-Synchronized" property in the register description.

## 22.5.6 Additional Features

### 22.5.6.1 Always-On Mode

The Always-On mode is enabled by setting the Always-On bit in the Control A register ([CTRLA.ALWAYSON=1](#)). When the Always-On mode is enabled, the WDT runs continuously, regardless of the state of [CTRLA.ENABLE](#). Once written, the Always-On bit can only be cleared by a power-on reset. The Configuration ([CONFIG](#)) and Early Warning Control ([EWCTRL](#)) registers are read-only registers while the [CTRLA.ALWAYSON](#) bit is set. Thus, the time period configuration bits ([CONFIG.PER](#), [CONFIG.WINDOW](#), [EWCTRL.EWOFFSET](#)) of the WDT cannot be changed.

Enabling or disabling Window mode operation by writing the Window Enable bit ([CTRLA.WEN](#)) is allowed while in Always-On mode, but note that [CONFIG.PER](#) cannot be changed.

The Interrupt Clear and Interrupt Set registers are accessible in the Always-On mode. The Early Warning interrupt can still be enabled or disabled while in the Always-On mode, but note that [EWCTRL.EWOFFSET](#) cannot be changed.

Table WDT Operating Modes With Always-On shows the operation of the WDT for [CTRLA.ALWAYSON=1](#).

**Table 22-2.** WDT Operating Modes With Always-On

WEN	Interrupt Enable	Mode
0	0	Always-on and normal mode
0	1	Always-on and normal mode with Early Warning interrupt
1	0	Always-on and window mode
1	1	Always-on and window mode with Early Warning interrupt

### 22.5.6.2 Early Warning

The Early Warning interrupt notifies that the WDT is approaching its time-out condition. The Early Warning interrupt behaves differently in Normal mode and in Window mode.

*In Normal mode*, the Early Warning interrupt generation is defined by the Early Warning Offset in the Early Warning Control register ([EWCTRL.EWOFFSET](#)). The Early Warning Offset bits define the number of [CLK\\_WDT\\_OSC](#) clocks before the interrupt is generated, relative to the start of the watchdog time-out period.

The user must take caution when programming the Early Warning Offset bits. If these bits define an Early Warning interrupt generation time greater than the watchdog time-out period, the watchdog time-out system reset is generated prior to the Early Warning interrupt. Consequently, the Early Warning interrupt will never be generated.

*In window mode*, the Early Warning interrupt is generated at the start of the open window period. In a typical application where the system is in sleep mode, the Early Warning interrupt can be used to wake up and clear the Watchdog Timer, after which the system can perform other tasks or return to sleep mode.

**Example:** If the WDT is operating in Normal mode with `CONFIG.PER = 0x2` and `EWCTRL.EWOFFSET = 0x1`, the Early Warning interrupt is generated 16 `CLK_WDT_OSC` clock cycles after the start of the time-out period. The time-out system reset is generated 32 `CLK_WDT_OSC` clock cycles after the start of the watchdog time-out period.

## 22.6 Register Summary

Offset	Name	Bit Pos.	7	6	5	4	3	2	1	0	
0x00	<a href="#">CTRLA</a>	7:0	ALWAYSON					WEN	ENABLE		
0x01	<a href="#">CONFIG</a>	7:0	WINDOW[3:0]			PER[3:0]					
0x02	<a href="#">EWCTRL</a>	7:0	EWOFFSET[3:0]								
0x03	Reserved										
0x04	<a href="#">INTENCLR</a>	7:0									
0x05	<a href="#">INTENSET</a>	7:0									
0x06	<a href="#">INTFLAG</a>	7:0									
0x07	Reserved										
0x08	<a href="#">SYNCBUSY</a>	7:0				CLEAR	ALWAYSON	WEN	ENABLE		
		15:8									
		23:16									
		31:24									
0x0C	<a href="#">CLEAR</a>	7:0	CLEAR[7:0]								



## 22.6.1 Control A

**Name:** CTRLA  
**Offset:** 0x00  
**Reset:** x initially determined from NVM User Row after reset  
**Property:** PAC Write-Protection, Write-Synchronized Bits

Bit	7	6	5	4	3	2	1	0
	ALWAYSON					WEN	ENABLE	
Access	R/W					R/W	R/W	
Reset	x					x	x	

### Bit 7 - ALWAYSON Always-On

This bit allows the WDT to run continuously. After being set, this bit cannot be written to '0', and the WDT will remain enabled until a power-on Reset is received. When this bit is '1', the Control A register (CTRLA), the Configuration register (CONFIG) and the Early Warning Control register (EWCTRL) will be read-only, and any writes to these registers are not allowed.

Writing a '0' to this bit has no effect.

This bit is loaded from [NVM User Row](#) at start-up.

Value	Description
0	The WDT is enabled and disabled through the ENABLE bit.
1	The WDT is enabled and can only be disabled by a power-on reset (POR).

### Bit 2 - WEN Watchdog Timer Window Mode Enable

This bit enables Window mode. It can only be written if the peripheral is disabled unless CTRLA.ALWAYSON=1.

This bit is loaded from [NVM User Row](#) at startup.

Value	Description
0	Window mode is disabled (normal operation).
1	Window mode is enabled.

### Bit 1 - ENABLE Enable

This bit enables or disables the WDT. It can only be written if CTRLA.ALWAYSON=0.

Due to synchronization, there is delay between writing CTRLA.ENABLE until the peripheral is enabled/disabled. The value written to CTRLA.ENABLE will read back immediately, and the Enable bit in the Synchronization Busy register (SYNCBUSY.ENABLE) will be set. SYNCBUSY.ENABLE will be cleared when the operation is complete.

This bit is loaded from [NVM User Row](#) at startup.

Value	Description
0	The WDT is disabled.
1	The WDT is enabled.

## 22.6.2 Configuration

**Name:** CONFIG  
**Offset:** 0x01  
**Reset:** x initially determined from NVM User Row after reset  
**Property:** PAC Write-Protection

Bit	7	6	5	4	3	2	1	0
	WINDOW[3:0]				PER[3:0]			
Access	R/W	R/W	R/W	R/W	R/W	R/W	R/W	R/W
Reset	x	x	x	x	x	x	x	x

### Bits 7:4 – WINDOW[3:0] Window Mode Time-Out Period

In Window mode, these bits determine the watchdog closed window period as a number of cycles of the 1.024 kHz CLK\_WDT\_OSC clock.

These bits are loaded from [NVM User Row](#) at start-up.

Value	Name	Description
0x0	CYC8	8 clock cycles
0x1	CYC16	16 clock cycles
0x2	CYC32	32 clock cycles
0x3	CYC64	64 clock cycles
0x4	CYC128	128 clock cycles
0x5	CYC256	256 clock cycles
0x6	CYC512	512 clock cycles
0x7	CYC1024	1024 clock cycles
0x8	CYC2048	2048 clock cycles
0x9	CYC4096	4096 clock cycles
0xA	CYC8192	8192 clock cycles
0xB	CYC16384	16384 clock cycles
0xC–0xF	Reserved	Reserved

### Bits 3:0 – PER[3:0] Time-Out Period

These bits determine the watchdog time-out period as a number of 1.024 kHz CLK\_WDTOSC clock cycles. In Window mode operation, these bits define the open window period.

These bits are loaded from [NVM User Row](#) at startup.

Value	Name	Description
0x0	CYC8	8 clock cycles
0x1	CYC16	16 clock cycles
0x2	CYC32	32 clock cycles
0x3	CYC64	64 clock cycles
0x4	CYC128	128 clock cycles
0x5	CYC256	256 clock cycles
0x6	CYC512	512 clock cycles
0x7	CYC1024	1024 clock cycles
0x8	CYC2048	2048 clock cycles
0x9	CYC4096	4096 clock cycles
0xA	CYC8192	8192 clock cycles
0xB	CYC16384	16384 clock cycles
0xC – 0xF	-	Reserved

### 22.6.3 Early Warning Control

**Name:** EWCTRL  
**Offset:** 0x02  
**Reset:** x initially determined from NVM User Row after reset  
**Property:** PAC Write-Protection, Enable-Protected

Bit	7	6	5	4	3	2	1	0
					EWOFFSET[3:0]			
Access					R/W	R/W	R/W	R/W
Reset					x	x	x	x

#### Bits 3:0 – EWOFFSET[3:0] Early Warning Interrupt Time Offset

These bits determine the number of GCLK\_WDT clock cycles between the start of the watchdog time-out period and the generation of the Early Warning interrupt. These bits are loaded from [NVM User Row](#) at start-up.

Value	Name	Description
0x0	CYC8	8 clock cycles
0x1	CYC16	16 clock cycles
0x2	CYC32	32 clock cycles
0x3	CYC64	64 clock cycles
0x4	CYC128	128 clock cycles
0x5	CYC256	256 clock cycles
0x6	CYC512	512 clock cycles
0x7	CYC1024	1024 clock cycles
0x8	CYC2048	2048 clock cycles
0x9	CYC4096	4096 clock cycles
0xA	CYC8192	8192 clock cycles
0xB – 0xF	Reserved	Reserved

## 22.6.4 Interrupt Enable Clear

**Name:** INTENCLR  
**Offset:** 0x04  
**Reset:** 0x00  
**Property:** PAC Write-Protection

This register allows the user to disable an interrupt without doing a read-modify-write operation. Changes in this register will also be reflected in the Interrupt Enable Set (INTENSET) register.

Bit	7	6	5	4	3	2	1	0
								EW
Access								R/W
Reset								0

### Bit 0 – EW Early Warning Interrupt Enable

Writing a '0' to this bit has no effect.

Writing a '1' to this bit clears the Early Warning Interrupt Enable bit, which disables the Early Warning interrupt.

Value	Description
0	The Early Warning interrupt is disabled.
1	The Early Warning interrupt is enabled.

## 22.6.5 Interrupt Enable Set

**Name:** INTENSET  
**Offset:** 0x05  
**Reset:** 0x00  
**Property:** PAC Write-Protection

This register allows the user to enable an interrupt without doing a read-modify-write operation. Changes in this register will also be reflected in the Interrupt Enable Clear (INTENCLR) register.

Bit	7	6	5	4	3	2	1	0
								EW
Access								R/W
Reset								0

### Bit 0 – EW Early Warning Interrupt Enable

Writing a '0' to this bit has no effect.

Writing a '1' to this bit sets the Early Warning Interrupt Enable bit, which enables the Early Warning interrupt.

Value	Description
0	The Early Warning interrupt is disabled.
1	The Early Warning interrupt is enabled.

## 22.6.6 Interrupt Flag Status and Clear

**Name:** INTFLAG  
**Offset:** 0x06  
**Reset:** 0x00  
**Property:** N/A

Bit	7	6	5	4	3	2	1	0
								EW
Access								R/W
Reset								0

### Bit 0 – EW Early Warning

This flag is cleared by writing a '1' to it.

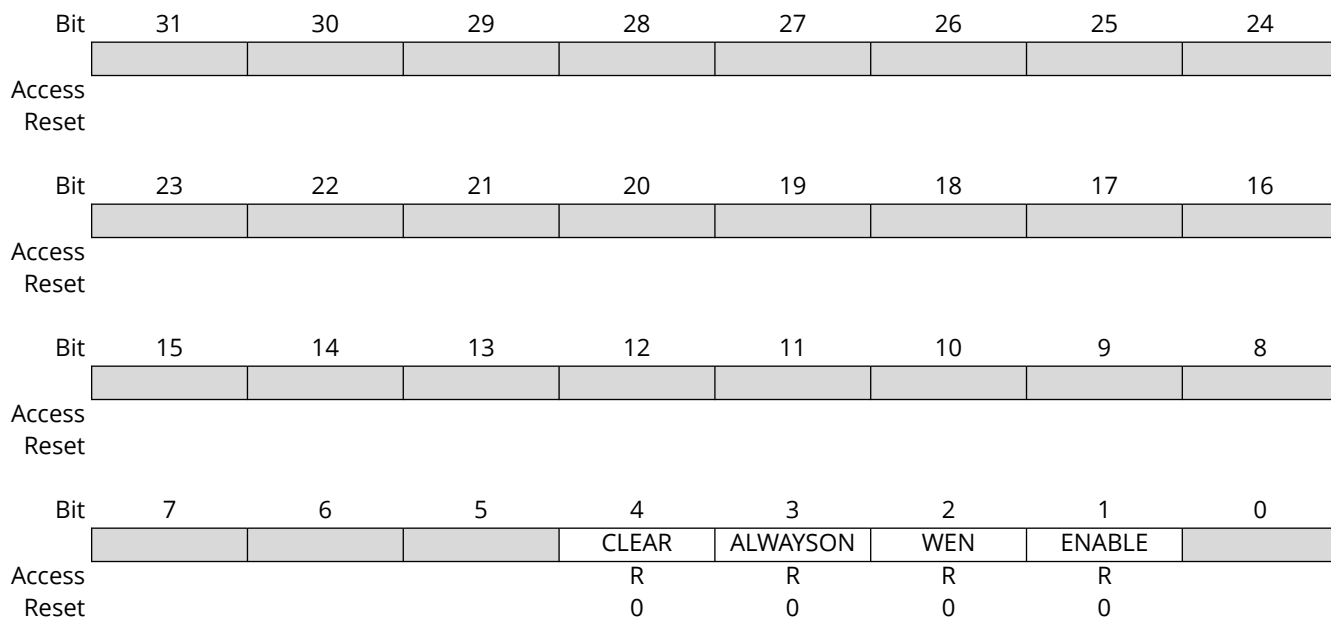
This flag is set when an Early Warning interrupt occurs, as defined by the EWOFFSET bit group in EWCTRL.

Writing a '0' to this bit has no effect.

Writing a '1' to this bit clears the Early Warning interrupt flag.

## 22.6.7 Synchronization Busy

**Name:** SYNCBUSY  
**Offset:** 0x08  
**Reset:** 0x00000000  
**Property:** -



### Bit 4 - CLEAR Clear Synchronization Busy

Value	Description
0	Write synchronization of the CLEAR register is complete.
1	Write synchronization of the CLEAR register is ongoing.

### Bit 3 - ALWAYS ON Always-On Synchronization Busy

Value	Description
0	Write synchronization of the CTRLA.ALWAYSON bit is complete.
1	Write synchronization of the CTRLA.ALWAYSON bit is ongoing.

### Bit 2 - WEN Window Enable Synchronization Busy

Value	Description
0	Write synchronization of the CTRLA.WEN bit is complete.
1	Write synchronization of the CTRLA.WEN bit is ongoing.

### Bit 1 - ENABLE Enable Synchronization Busy

Value	Description
0	Write synchronization of the CTRLA.ENABLE bit is complete.
1	Write synchronization of the CTRLA.ENABLE bit is ongoing.

## 22.6.8 Clear

**Name:** CLEAR  
**Offset:** 0x0C  
**Reset:** 0x00  
**Property:** Write-Synchronized

**Note:** This register is write-synchronized: SYNCBUSY.CLEAR must be checked to ensure the CLEAR register synchronization is complete.

Bit	7	6	5	4	3	2	1	0
	CLEAR[7:0]							
Access	W	W	W	W	W	W	W	W
Reset	0	0	0	0	0	0	0	0

### Bits 7:0 – CLEAR[7:0] Watchdog Clear

In Normal mode, writing 0xA5 to this register during the watchdog time-out period will clear the Watchdog Timer and the watchdog time-out period is restarted.

In Window mode, any writing attempt to this register before the time-out period started (i.e., during  $TO_{WDTW}$ ) will issue an immediate system Reset. Writing 0xA5 during the time-out period  $TO_{WDT}$  will clear the Watchdog Timer and the complete time-out sequence (first  $TO_{WDTW}$  then  $TO_{WDT}$ ) is restarted.

In both modes, writing any other value than 0xA5 will issue an immediate system Reset.



## 23. Real-Time Counter (RTC)

### 23.1 Overview

The Real-Time Counter (RTC) is a 32-bit counter with a 10-bit programmable prescaler that typically runs continuously to keep track of time. The RTC can wake up the device from sleep modes using the alarm/compare wake up, periodic wake up, or overflow wake up mechanisms, or from the wake inputs.

The RTC can generate periodic peripheral events from outputs of the prescaler, as well as alarm/compare interrupts and peripheral events, which can trigger at any counter value. Additionally, the timer can trigger an overflow interrupt and overflow event, and can be reset on the occurrence of an alarm/compare match. This allows periodic interrupts and peripheral events at very long and accurate intervals.

The 10-bit programmable prescaler can scale down the clock source. By this, a wide range of resolutions and time-out periods can be configured. With a 32.768 kHz clock source, the minimum counter tick interval is 30.5 $\mu$ s, and time-out periods can range up to 36 hours. For a counter tick interval of 1s, the maximum time-out period is more than 136 years.

### 23.2 Features

The following are key features of the RTC module:

- 32-bit counter with 10-bit prescaler
- Multiple clock sources
- 32-bit or 16-bit counter mode
- Two 32-bit or four 16-bit compare values
- Clock/Calendar mode
  - Time in seconds, minutes, and hours (12/24)
  - Date in day of month, month, and year
  - Leap year correction
- Digital prescaler correction/tuning for increased accuracy
- Overflow, alarm/compare match, and prescaler interrupts and events
  - Optional clear on alarm/compare match
- 8 backup registers with retention capability
- Tamper Detection
  - Timestamp on event or up to 5 inputs with debouncing
  - Active layer protection

## 23.3 Block Diagram

Figure 23-1. RTC Block Diagram (Mode 0 — 32-Bit Counter)

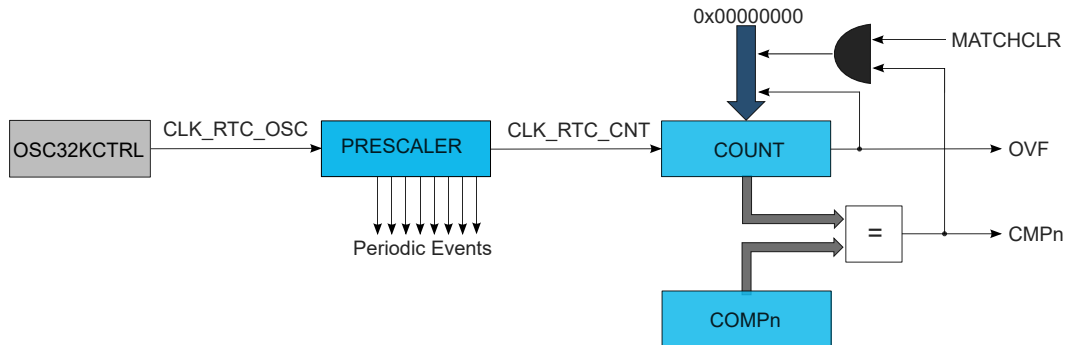


Figure 23-2. RTC Block Diagram (Mode 1 — 16-Bit Counter)

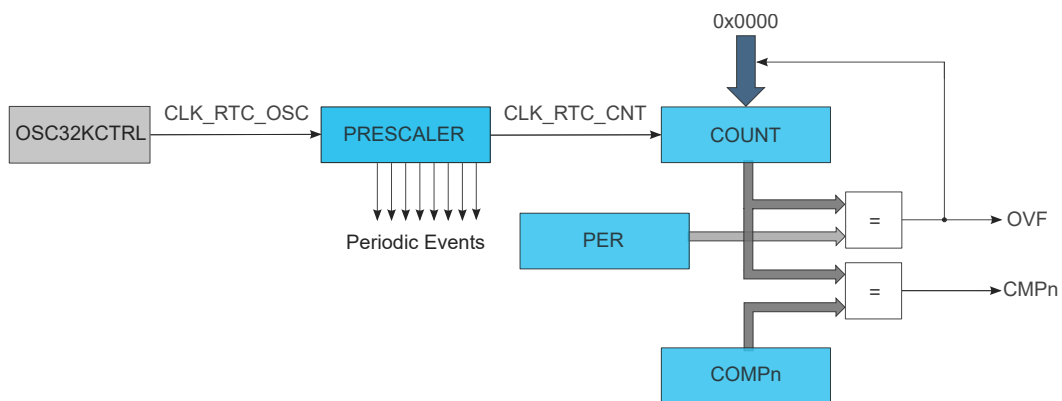
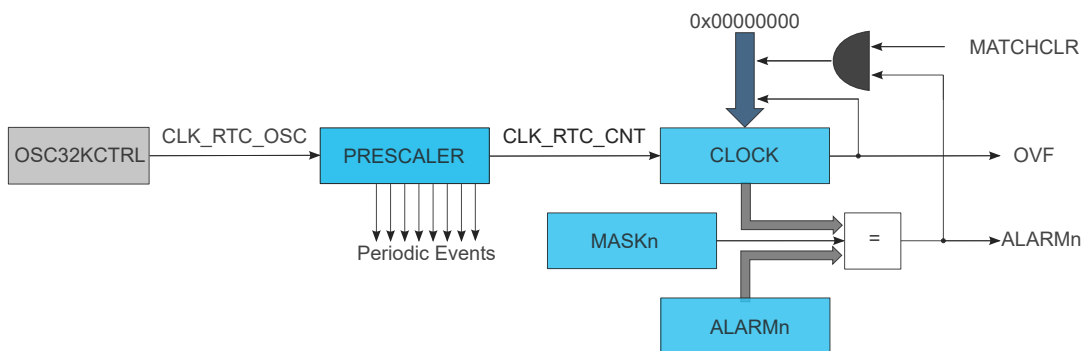


Figure 23-3. RTC Block Diagram (Mode 2 — Clock/Calendar)



## 23.4 Signal Description

Table 23-1. Signal Description

Signal	Description	Type
INn [n=0..3]	Tamper Detection Input	Digital input
OUT	Tamper Detection Output	Digital output

One signal can be mapped to one of several pins.

## 23.5 Peripheral Dependencies

<b>Peripheral Name</b>	Real-Time Counter (RTC)
<b>Base Address</b>	0x4000_2400 (Peripheral Bus A)
<b>NVIC IRQ Index:Source</b>	11 : ALARM0, ALARM1, CMP0 , CMP1, CMP2, CMP3, OVF, PER0, PER1, PER2, PER3, PER4, PER5, PER6, PER7, TAMPER
<b>MCLK APB Clock (1)</b>	CLK_RTC_APB, Enabled, APBAMASK.RTC
<b>GCLK Peripheral Channel Index:Clock Name (2)</b>	n/a
<b>PAC Peripheral Identifier (PAC.WRCTRL)</b>	9
<b>DMA Trigger Index:Source (DMAC.CHCTRLAk,k = 0,1,...31)</b>	1 : DMA Timestamp (TIMESTAMP)
<b>EVSYS Users (EVSYS.USERm) (3)</b>	0 : RTC Tamper (RTC_TAMPER) (A)
<b>EVSYS Generators (EVSYS.CHANNELn)</b>	4-11 : RTC Period x, x = 0..7 (RTC_PERx) 12-15 : RTC Comparison x, x=0..3 (RTC_CMPx) 16 : RTC Tamper Detection (RTC_TAMPER) 17 : RTC Overflow (RTC_OVF)
<b>Notes:</b>	
	<ol style="list-style-type: none"> <li>1. Clock Name, Default State, Mask Field.</li> <li>2. Refer to the GCLK.PCHCTRLm register, where m = Index.</li> <li>3. (A,S,R): A = Asynchronous path, S = Synchronous path, R = Resynchronized path.</li> </ol>

### 23.5.1 I/O Lines

For more information on I/O configurations, refer to the [Pinout](#) section.

### 23.5.2 Power Management

The RTC will continue to operate in any sleep modes where the selected source clock is running. The RTC interrupts can be used to wake up the device from sleep modes. Events connected to the event system can trigger other operations in the system without exiting sleep modes. Refer to the [Power Manager](#) for details on the different sleep modes.

The RTC can only be reset by a Power-on Reset (POR) or by setting the Software Reset bit in the Control A register (`CTRLA.SWRST = 1`).

### 23.5.3 Clocks

The RTC bus clock (CLK\_RTC\_APB) can be enabled and disabled in the Main Clock module MCLK, and the default state of CLK\_RTC\_APB can be found in [Peripheral Clock Masking](#) section.

A 32.768 kHz or 1.024 kHz oscillator clock (CLK\_RTC\_OSC) is required to clock the RTC. This clock must be configured and enabled in the [32.768 kHz oscillator controller](#) (OSC32KCTRL.RTCCTRL.RTCSEL) before using the RTC.

This oscillator clock is asynchronous to the bus clock (CLK\_RTC\_APB). Due to this asynchronicity, writing to certain registers will require synchronization between the clock domains. Refer to [23.6.7. Synchronization](#) for further details.

### 23.5.4 Debug Operation

When the CPU is halted in Debug mode the RTC will halt normal operation. The RTC can be forced to continue operation during debugging. Refer to the [23.7.7. DBGCTRL](#) for additional information.

### 23.5.5 Register Access Protection

All registers with write-access are optionally write-protected by the [Peripheral Access Controller \(PAC\)](#), except the following registers:

- Interrupt Flag Status and Clear ([INTFLAG](#)) register

Write-protection is denoted by the "PAC Write-Protection" property in the register description.

Write-protection does not apply to accesses through an external debugger. Refer to the [Peripheral Access Controller \(PAC\)](#) for details.

### 23.5.6 Analog Connections

A 32.768 kHz crystal can be connected to the XIN32 and XOUT32 pins, along with any required load capacitors. See the Electrical Characteristics Chapters for details on recommended crystal characteristics and load capacitors.

## 23.6 Functional Description

### 23.6.1 Principle of Operation

The RTC keeps track of time in the system and enables periodic events, as well as interrupts and events at a specified time. The RTC consists of a 10-bit prescaler that feeds a 32-bit counter. The actual format of the 32-bit counter depends on the RTC operating mode.

The RTC can function in one of these modes:

- Mode 0 - COUNT32: RTC serves as 32-bit counter
- Mode 1 - COUNT16: RTC serves as 16-bit counter
- Mode 2 - CLOCK: RTC serves as clock/calendar with alarm functionality

### 23.6.2 Basic Operation

#### 23.6.2.1 Initialization

The following bits are enable-protected, meaning that they can only be written when the RTC is disabled (CTRLA.ENABLE = 0):

- Operating Mode bits in the Control A register (CTRLA.MODE)
- Prescaler bits in the Control A register (CTRLA.PRESCALER)
- Clear on Match bit in the Control A register (CTRLA.MATCHCLR)
- Clock Representation bit in the Control A register (CTRLA.CLKREP)

The following registers are enable-protected:

- Control B register (CTRLB)
- Event Control register (EVCTRL)
- Tamper Control register (TAMPCTRL)

Enable-protected bits and registers can be changed only when the RTC is disabled (CTRLA.ENABLE = 0). If the RTC is enabled (CTRLA.ENABLE = 1), these operations are necessary: first write CTRLA.ENABLE = 0 and check whether the write synchronization has finished, then change the desired bit field value. Enable-protected bits in CTRLA register can be written at the same time as CTRLA.ENABLE is written to '1', but not at the same time as CTRLA.ENABLE is written to '0'.

Enable-protection is denoted by the "Enable-Protected" property in the register description.

The RTC prescaler divides the source clock for the RTC counter.

**Note:** In Clock/Calendar mode, the prescaler must be configured to provide a 1.024 kHz clock to the counter for correct operation.

The frequency of the RTC clock (CLK\_RTC\_CNT) is given by the following formula:

$$f_{\text{CLK\_RTC\_CNT}} = \frac{f_{\text{CLK\_RTC\_OSC}}}{2^{\text{PRESCALER}}}$$

The frequency of the oscillator clock, CLK\_RTC\_OSC, is given by  $f_{\text{CLK\_RTC\_OSC}}$ , and  $f_{\text{CLK\_RTC\_CNT}}$  is the frequency of the internal prescaled RTC clock, CLK\_RTC\_CNT.

### 23.6.2.2 Enabling, Disabling, and Resetting

The RTC is enabled by setting the Enable bit in the Control A register (CTRLA.ENABLE = 1). The RTC is disabled by writing CTRLA.ENABLE = 0.

The RTC is reset by setting the Software Reset bit in the Control A register (CTRLA.SWRST = 1). All registers in the RTC, except DEBUG, will be reset to their initial state, and the RTC will be disabled. The RTC must be disabled before resetting it.

### 23.6.2.3 32-Bit Counter (Mode 0)

When the RTC Operating Mode bits in the Control A register (CTRLA.MODE) are written to 0x0, the counter operates in 32-bit Counter mode. The block diagram of this mode is shown in [Figure 23-1](#). When the RTC is enabled, the counter will increment on every 0-to-1 transition of CLK\_RTC\_CNT. The counter will increment until it reaches the top value of 0xFFFFFFFF, and then wrap to 0x00000000. This sets the Overflow Interrupt flag in the Interrupt Flag Status and Clear register (INTFLAG.OVF).

The RTC counter value can be read from or written to the Counter Value register (COUNT) in 32-bit format.

The counter value is continuously compared with the 32-bit Compare registers (COMPn, n=0-1). When a compare match occurs, the Compare n Interrupt flag in the Interrupt Flag Status and Clear register (INTFLAG.CMPn) is set on the next 0-to-1 transition of CLK\_RTC\_CNT.

If the Clear on Match bit in the Control A register (CTRLA.MATCHCLR) is '1', the counter is cleared on the next counter cycle when a compare match with COMPn occurs. This allows the RTC to generate periodic interrupts or events with longer periods than the prescaler events. Note that when CTRLA.MATCHCLR is '1', INTFLAG.CMPn and INTFLAG.OVF will both be set simultaneously on a compare match with COMPn.

### 23.6.2.4 16-Bit Counter (Mode 1)

When the RTC Operating Mode bits in the Control A register (CTRLA.MODE) are written to 0x1, the counter operates in 16-bit Counter mode as shown in [Figure 23-2](#). When the RTC is enabled, the counter will increment on every 0-to-1 transition of CLK\_RTC\_CNT. In 16-bit Counter mode, the 16-bit Period register (PER) holds the maximum value of the counter. The counter will increment until it reaches the PER value, and then wrap to 0x0000. This sets the Overflow Interrupt flag in the Interrupt Flag Status and Clear register (INTFLAG.OVF).

The RTC counter value can be read from or written to the Counter Value register (COUNT) in 16-bit format.

The counter value is continuously compared with the 16-bit Compare registers (COMPn, n=0..). When a compare match occurs, the Compare n Interrupt flag in the Interrupt Flag Status and Clear register (INTFLAG.CMPn, n=0..) is set on the next 0-to-1 transition of CLK\_RTC\_CNT.

### 23.6.2.5 Clock/Calendar (Mode 2)

When the RTC Operating Mode bits in the Control A register (CTRLA.MODE) are written to 0x2, the counter operates in Clock/Calendar mode, as shown in [Figure 23-3](#). When the RTC is enabled, the counter will increment on every 0-to-1 transition of CLK\_RTC\_CNT. The selected clock source and RTC prescaler must be configured to provide a 1Hz clock to the counter for correct operation in this mode.

The time and date can be read from or written to the Clock Value register (CLOCK) in a 32-bit time/date format. Time is represented as:

- Seconds
- Minutes
- Hours

Hours can be represented in either 12- or 24-hour format, selected by the Clock Representation bit in the Control A register (CTRLA.CLKREP). This bit can be changed only while the RTC is disabled.

The date is represented in this form:

- Day as the numeric day of the month (starting at 1)
- Month as the numeric month of the year (1 = January, 2 = February, etc.)
- Year as a value from 0x00 to 0x3F. This value must be added to a user-defined reference year. The reference year must be a leap year (2016, 2020 etc). Example: the year value 0x2D, added to a reference year 2016, represents the year 2061.

The RTC will increment until it reaches the top value of 23:59:59 December 31 of year value 0x3F, and then wrap to 00:00:00 January 1 of year value 0x00. This will set the Overflow Interrupt flag in the Interrupt Flag Status and Clear registers (INTFLAG.OVF).

The clock value is continuously compared with the 32-bit Alarm registers (ALARMn, n=0–1). When an alarm match occurs, the Alarm n Interrupt flag in the Interrupt Flag Status and Clear registers (INTFLAG.ALARMn, n=0..1) is set on the next 0-to-1 transition of CLK\_RTC\_CNT. E.g. For a 1Hz clock counter, it means the Alarm 0 Interrupt flag is set with a delay of 1s after the occurrence of alarm match.

A valid alarm match depends on the setting of the Alarm Mask Selection bits in the Alarm n Mask register (MASKn.SEL). These bits determine which time/date fields of the clock and alarm values are valid for comparison and which are ignored.

If the Clear on Match bit in the Control A register (CTRLA.MATCHCLR) is set, the counter is cleared on the next counter cycle when an alarm match with ALARMn occurs. This allows the RTC to generate periodic interrupts or events with longer periods than it would be possible with the prescaler events only (see [23.6.8.1. Periodic Intervals](#)).

**Note:** When CTRLA.MATCHCLR is 1, INTFLAG.ALARM0 and INTFLAG.OVF will both be set simultaneously on an alarm match with ALARMn.

### 23.6.3 DMA Operation

The RTC generates the following DMA request:

- Tamper (TAMPER): The request is set on capture of the timestamp. The request is cleared when the Timestamp register is read.

If the CPU accesses the registers which are source for DMA request set/clear condition, the DMA request can be lost or the DMA transfer can be corrupted, if enabled.

### 23.6.4 Interrupts

The RTC has the following interrupt sources:

- Overflow (OVF): Indicates that the counter has reached its top value and wrapped to zero.
- Tamper (TAMPER): Indicates detection of valid signal on a tamper input pin or tamper event input.
- Compare (CMPn): Indicates a match between the counter value and the compare register.
- Alarm (ALARMn): Indicates a match between the clock value and the alarm register.
- Period n (PERn): The corresponding bit in the prescaler has toggled. Refer to [23.6.8.1. Periodic Intervals](#) for details.

Each interrupt source has an interrupt flag associated with it. The interrupt flag in the Interrupt Flag Status and Clear (INTFLAG) register is set when the interrupt condition occurs. Each interrupt can be individually enabled by setting the corresponding bit in the Interrupt Enable Set register (INTENSET=1), and disabled by setting the corresponding bit in the Interrupt Enable Clear register (INTENCLR=1). The status of enabled interrupts can be read from either INTENSET or INTENCLR.

An interrupt request is generated when the interrupt flag is raised and the corresponding interrupt is enabled. The interrupt request remains active until either the interrupt flag is cleared, the interrupt is disabled or the RTC is reset. See the description of the INTFLAG registers for details on how to clear interrupt flags.

All interrupt requests from the peripheral are ORed together on system level to generate one combined interrupt request to the NVIC. Refer to the [Nested Vector Interrupt Controller](#) for details. The user must read the INTFLAG register to determine which interrupt condition is present.

**Note:** Interrupts must be globally enabled for interrupt requests to be generated. Refer to the Nested Vector Interrupt Controller for details.

### 23.6.5 Events

The RTC can generate the following output events:

- Overflow (OVF): Generated when the counter has reached its top value and wrapped to zero.
- Tamper (TAMPER): Generated on detection of valid signal on a tamper input pin or tamper event input.
- Compare (CMP0-1): Indicates a match between the counter value and the compare register.
- Alarm (ALARM0): Indicates a match between the clock value and the alarm register.
- Period n (PER0-7): The corresponding bit in the prescaler has toggled. Refer to [23.6.8.1. Periodic Intervals](#) for details.
- Periodic Daily (PERD): Generated when the COUNT/CLOCK has incremented at a fixed period of time.

Setting the Event Output bit in the Event Control Register (EVCTRL.xxxEO=1) enables the corresponding output event. Writing a zero to this bit disables the corresponding output event. Refer to the [EVSYS - Event System](#) for details on configuring the event system.

The RTC can take the following actions on an input event:

- Tamper (TAMPEVT): Capture the RTC counter to the timestamp register. See [Tamper Detection](#).

Writing a one to an Event Input bit into the Event Control register (EVCTRL.xxxEI) enables the corresponding action on input event. Writing a zero to this bit disables the corresponding action on input event.

### 23.6.6 Sleep Mode Operation

The RTC will continue to operate in any sleep mode where the source clock is active. The RTC *interrupts* can be used to wake up the device from a sleep mode. RTC *events* can trigger other operations in the system without exiting the sleep mode.

An interrupt request will be generated after the wake-up if the Interrupt Controller is configured accordingly. Otherwise the CPU will wake up directly, without triggering any interrupt. In this case, the CPU will continue executing right from the first instruction that followed the entry into sleep.

The periodic events can also wake up the CPU through the interrupt function of the Event System. In this case, the event must be enabled and connected to an event channel with its interrupt enabled. See [Event System](#) for more information.

### 23.6.7 Synchronization

Due to asynchronicity between the main clock domain and the peripheral clock domains, some registers need to be synchronized when written or read.

The following bits are synchronized when written:

- Software Reset bit in Control A register, CTRLA.SWRST
- Enable bit in Control A register, CTRLA.ENABLE
- Count Read Synchronization bit in Control A register (CTRLA.COUNTSYNC)
- Clock Read Synchronization bit in Control A register (CTRLA.COUNTSYNC)

The following registers are synchronized when written:

- Counter Value register, COUNT
- Clock Value register, CLOCK
- Counter Period register, PER
- Compare n Value registers, COMPn
- Alarm n Value registers, ALARMn
- Frequency Correction register, FREQCORR
- Alarm n Mask register, MASKn
- The General Purpose n registers (GPn)

The following registers are synchronized when read:

- The Counter Value register, COUNT, if the Counter Read Sync Enable bit in CTRLA (CTRLA.COUNTSYNC) is '1'
- The Clock Value register, CLOCK, if the Clock Read Sync Enable bit in CTRLA (CTRLA.CLOCKSYNC) is '1'
- The Timestamp Value register (TIMESTAMP)

Required write synchronization is denoted by the "Write-Synchronized" property in the register description.

Required read synchronization is denoted by the "Read-Synchronized" property in the register description.

## 23.6.8 Additional Features

### 23.6.8.1 Periodic Intervals

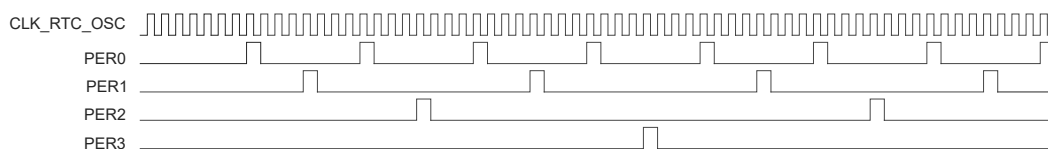
The RTC prescaler can generate interrupts and events at periodic intervals, allowing flexible system tick creation. Any of the upper eight bits of the prescaler (bits 2 to 9) can be the source of an interrupt/event. When one of the eight Periodic Event Output bits in the Event Control register (EVCTRL.PEREO[n=0..7]) is '1', an event is generated on the 0-to-1 transition of the related bit in the prescaler, resulting in a periodic event frequency of:

$$f_{\text{PERIODIC}(n)} = \frac{f_{\text{CLK\_RTC\_OSC}}}{2^{n+3}}$$

$f_{\text{CLK\_RTC\_OSC}}$  is the frequency of the internal prescaler clock CLK\_RTC\_OSC, and n is the position of the EVCTRL.PEREO[n] bit. For example, PER0 will generate an event every eight CLK\_RTC\_OSC cycles, PER1 every 16 cycles, etc. This is shown in the figure below.

Periodic events are independent of the prescaler setting used by the RTC counter, except if CTRLA.PRESCALER is zero. Then, no periodic events will be generated.

**Figure 23-4.** Example Periodic Events



**Note:** The same applies for interrupts enabled in INTENSET/CLR.

### 23.6.8.2 Frequency Correction

The RTC Frequency Correction module employs periodic counter corrections to compensate for a too-slow or too-fast oscillator. Frequency correction requires that CTRLA.PRESCALER is greater than 1.



The digital correction circuit adds or subtracts cycles from the RTC prescaler to adjust the frequency in approximately 1ppm steps. Digital correction is achieved by adding or skipping a single count in the prescaler once every 8192 CLK\_RTC\_OSC cycles. The Value bit group in the Frequency Correction register (FREQCORR.VALUE) determines the number of times the adjustment is applied over 128 of these periods. The resulting correction is as follows:

$$\text{Correction in ppm} = \frac{\text{FREQCORR.VALUE}}{8192 \cdot 128} \cdot 10^6 \text{ ppm}$$

This results in a resolution of 0.95367ppm.

The Sign bit in the Frequency Correction register (FREQCORR.SIGN) determines the direction of the correction. A positive value will add counts and increase the period (reducing the frequency), and a negative value will reduce counts per period (speeding up the frequency).

Digital correction also affects the generation of the periodic events from the prescaler. When the correction is applied at the end of the correction cycle period, the interval between the previous periodic event and the next occurrence may also be shortened or lengthened depending on the correction value.

### 23.6.8.3 Backup Registers

The RTC includes eight Backup registers (BKUPn). These registers maintain their content in Backup sleep mode. They can be used to store user-defined values.

If more user-defined data must be stored than the eight Backup registers can hold, the [General Purpose registers \(GPn\)](#) can be used.

### 23.6.8.4 General Purpose Registers

The RTC includes four General Purpose registers (GPn). These registers are reset only when the RTC is reset or when tamper detection occurs, and remain powered while the RTC is powered. They can be used to store user-defined values while other parts of the system are powered off.

The general purpose registers 2\*n and 2\*n+1 are enabled by writing a '1' to the General Purpose Enable bit n in the Control B register (CTRLB.GPnEN).

The GP registers share internal resources with the COMPARE/ALARM features. Each COMPARE/ALARM register have a separate read buffer and write buffer. When the general purpose feature is enabled the even GP uses the read buffer while the odd GP uses the write buffer.

When the COMPARE/ALARM register is written, the write buffer hold temporarily the COMPARE/ALARM value until the synchronization is complete (bit SYNCBUSY.COMPn going to 0). After the write is completed the write buffer can be used as a odd general purpose register without affecting the COMPARE/ALARM function.

If the COMPARE/ALARM function is not used, the read buffer can be used as an even general purpose register. In this case writing the even GP will temporarily use the write buffer until the synchronization is complete (bit SYNCBUSY.GPn going to 0). Thus an even GP must be written before writing the odd GP. Changing or writing an even GP needs to temporarily save the value of the odd GP.

Before using an even GP, the associated COMPARE/ALARM feature must be disabled by writing a '1' to the General Purpose Enable bit in the Control B register (CTRLB.GPnEN). To re-enable the compare/alarm, CTRLB.GPnEN must be written to zero and the associated COMPn/ALARMn must be written with the correct value.

An example procedure to write the general purpose registers GP0 and GP1 is:

1. Wait for any ongoing write to COMP0 to complete (SYNCBUSY.COMP0 = 0). If the RTC is operating in Mode 1, wait for any ongoing write to COMP1 to complete as well (SYNCBUSY.COMP1 = 0).
2. Write CTRLB.GP0EN = 1 if GP0 is needed.
3. Write GP0 if needed.

4. Wait for any ongoing write to GP0 to complete (SYNCBUSY.GP0 = 0). Note that GP1 will also show as busy when GP0 is busy.
5. Write GP1 if needed.

The following table provides the correspondence of General Purpose Registers and the COMPARE/ALARM read or write buffer in all RTC modes.

**Table 23-2.** General Purpose Registers Versus Compare/Alarm Registers: n in 0, 2, 4, 6...

Register	Mode 0	Mode 1	Mode 2	Write Before
GPn	COMPn/2 write buffer	(COMPn , COMPn+1) write buffer	ALARM0 write buffer	GPn+1
GPn+1	COMPn/2 read buffer	(COMPn , COMPn+1) read buffer	ALARM0 read buffer	-

### 23.6.8.5 Tamper Detection

The RTC provides five tamper channels that can be used for tamper detection.

The action of each tamper channel is configured using the Input n Action bits in the Tamper Control register (TAMPCTRL.INnACT):

- Off: Detection for tamper channel n is disabled.
- Wake: A transition on INn input (tamper channel n) matching TAMPCTRL.TAMLVLn will be detected and the tamper interrupt flag (INTFLAG.TAMPER) will be set. The RTC value will not be captured in the TIMESTAMP register.
- Capture: A transition on INn input (tamper channel n) matching TAMPCTRL.TAMLVLn will be detected and the tamper interrupt flag (INTFLAG.TAMPER) will be set. The RTC value will be captured in the TIMESTAMP register.
- Active Layer Protection: A mismatch of an internal RTC signal routed between INn and OUT pins will be detected and the tamper interrupt flag (INTFLAG.TAMPER) will be set. The RTC value will be captured in the TIMESTAMP register.

In order to determine which tamper source caused a tamper event, the Tamper ID register (TAMPID) provides the detection status of each tamper channel. These bits remain active until cleared by software.

A single interrupt request (TAMPER) is available for all tamper channels.

**Note:** Tamper interrupts must be ignored until 10 RTC clock periods after the RTC tamper detection is enabled.

The RTC also supports an input event (TAMPEVT) for generating a tamper condition within the Event System. The tamper input event is enabled by the Tamper Input Event Enable bit in the Event Control register (EVCTRL.TAMPEVTEI).

Up to five polarity external inputs (INn) can be used for tamper detection. The polarity for each input is selected with the Tamper Level bits in the Tamper Control register (TAMPCTRL.TAMLVLn).

Separate debouncers are embedded for each external input. The debouncer for each input is enabled/disabled with the Debounce Enable bits in the Tamper Control register (TAMPCTRL.DEBNCn). The debouncer configuration is fixed for all inputs as set by the Control B register (CTRLB). The debouncing period duration is configurable using the Debounce Frequency field in the Control B register (CTRLB.DEBF). The period is set for all debouncers (i.e., the duration cannot be adjusted separately for each debouncer).

When TAMPCTRL.DEBNCn = 0, INn is detected asynchronously. See Figure 23-5 *Edge Detection with Debouncer Disabled* for an example.

When TAMPCTRL.DEBNCn = 1, the detection time depends on whether the debouncer operates synchronously. Refer to the table below for more details. Synchronous versus asynchronous stability

debouncing is configured by the Debounce Asynchronous Enable bit in the Control B register (CTRLB.DEBASYNC):

- Synchronous (CTRLB.DEBASYNC = 0): INn is synchronized in two CLK\_RTC periods and then must remain stable for four CLK\_RTC\_DEB periods before a valid detection occurs. See Figure 23-6 *Edge Detection with Synchronous Stability Debouncing* for an example.
- Asynchronous (CTRLB.DEBASYNC = 1): The first edge on INn is detected. Further detection is blanked until INn remains stable for four CLK\_RTC\_DEB periods. See Figure 23-7 *Edge Detection with Asynchronous Stability Debouncing* for an example.

**Table 23-3.** Debouncer Configuration

TAMPCTRL. DEBNCn	CTRLB. DEBASYNC	Description
0	X	Detect edge on INn with no debouncing. Every edge detected is immediately triggered.
1	0	Detect edge on INn with synchronous stability debouncing. Edge detected is only triggered when INn is stable for 4 consecutive CLK_RTC_DEB periods.
1	1	Detect edge on INn with asynchronous stability debouncing. First detected edge is triggered immediately. All subsequent detected edges are ignored until INn is stable for 4 consecutive CLK_RTC_DEB periods.

**Figure 23-5.** Edge Detection with Debouncer Disabled

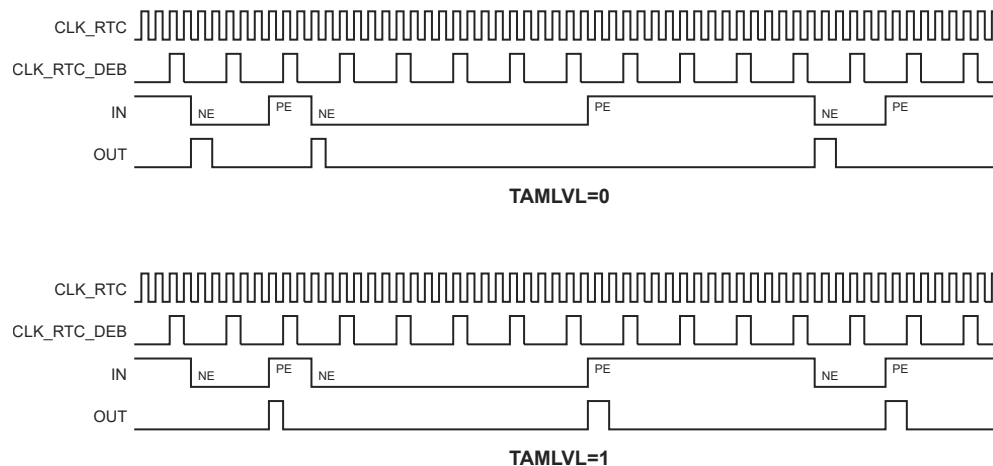


Figure 23-6. Edge Detection with Synchronous Stability Debouncing

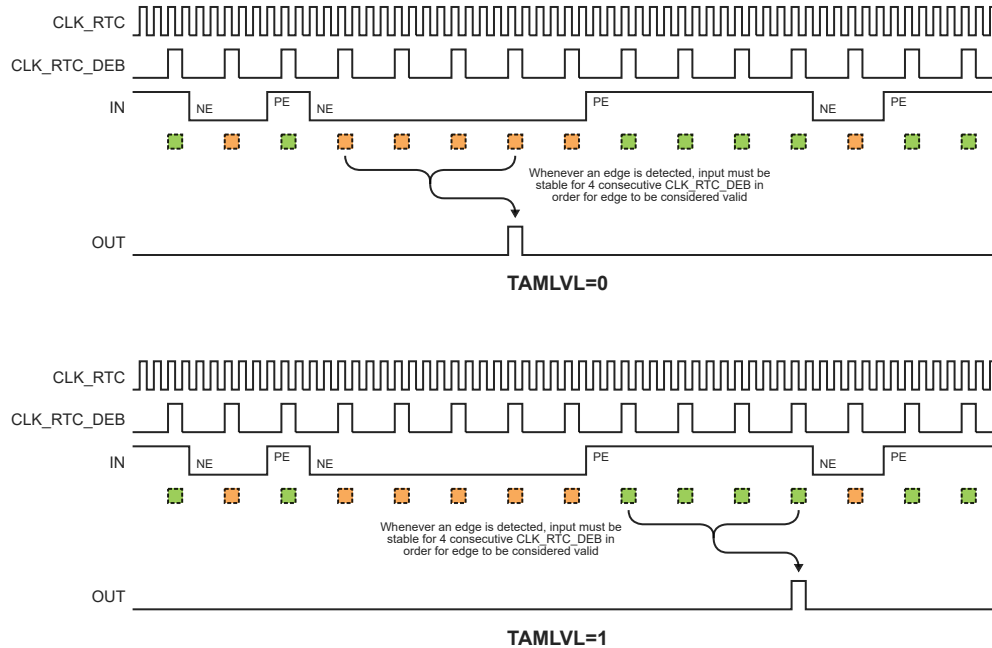
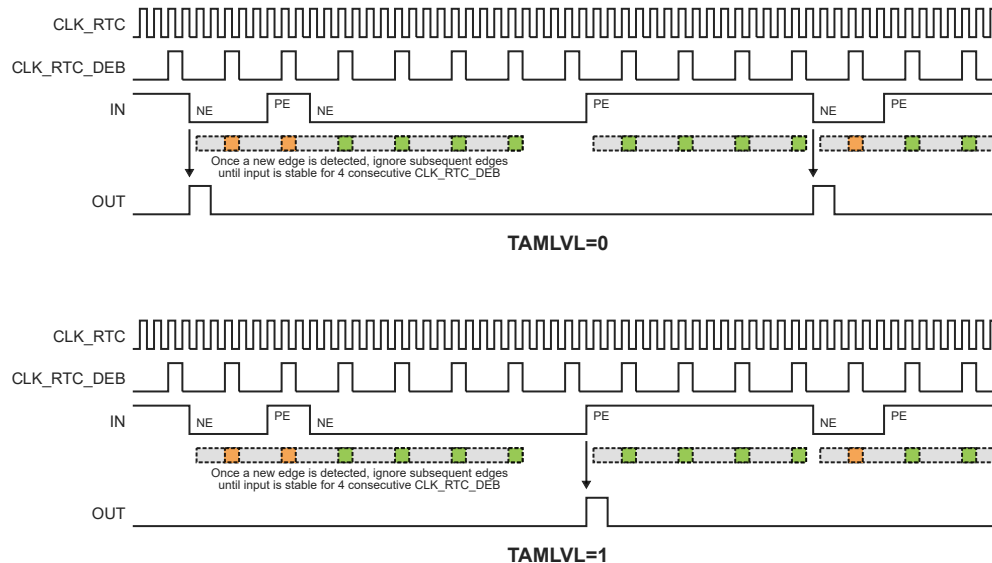


Figure 23-7. Edge Detection with Asynchronous Stability Debouncing



### 23.6.8.5.1 Timestamp

As part of tamper detection the RTC can capture the counter value (COUNT/CLOCK) into the TIMESTAMP register. Three CLK\_RTC periods are required to detect the tampering condition and capture the value. The TIMESTAMP value can be read once the Tamper flag in the Interrupt Flag register (INTFLAG.TAMPER) is set.

**Note:** In this case, the user should not read the TIMESTAMP register from the CPU. The read access to the TIMESTAMP register must be left to the DMA.

If the DMA Enable bit in the Control B register (CTRLB.DMAEN) is '1', a DMA request will be triggered by the timestamp. In order to determine which tamper source caused a capture, the Tamper ID

register (TAMPID) provides the detection status of each tamper channel and the tamper input event. A DMA transfer can then read both TIMESTAMP and TAMPID in succession.

A new timestamp value cannot be captured until the Tamper flag is cleared, either by reading the timestamp (CTRLB.DMAEN = 1) or by writing a '1' to INTFLAG.TAMPER (CTRLB.DMAEN = 0). If several tamper conditions occur in a short window before the timestamp is read, only the first timestamp may be logged. However, the detection of each tamper will still be recorded in TAMPID.

The Tamper Input Event (TAMPEVT) will always perform a timestamp capture. To capture on the external inputs (INn), the corresponding Input Action field in the Tamper Control register (TAMPCTRL.INnACT) must be written to '1'. If an input is set for wake functionality it does not capture the timestamp; however the Tamper flag and TAMPID will still be updated.

**Notes:**

1. The TIMESTAMP value should be read once, and INTFLAG.TAMPER must be cleared. The next value should be read only after the INTFLAG.TAMPER is set again.
2. If an external reset occurs during a tamper detection the TIMESTAMP register is permanently locked until the next power up. To avoid that specific situation do not use the Timestamp register and DMA upload, instead enable the RTC tamper interrupt, and in the tamper `irq` routine, copy the value from the RTC CLOCK register to one of the following destinations: SRAM, RTC GPx or BKUPx registers as the timestamp value.
3. The Timestamp capture feature is not functional in battery Backup mode.

**23.6.8.5.2 Active Layer Protection**

The RTC provides a mean of detecting broken traces on the PCB, also known as Active Layer Protection. In this mode, a generated internal RTC signal can be routed over critical components on the board using the RTC OUT output pin to one of the RTC INn input pins. A tamper condition is detected if there is a mismatch on the generated RTC signal.

The Active Layer Protection mode and the generation of the RTC signal is enabled by setting the RTCOUT bit in the Control B register (CTRLB.RTCOUT).

Enabling Active Layer protection requires the following steps:

- Enable the RTC prescaler output by writing a one to the RTC Out bit in the Control B register (CTRLB.RTCOUT). The I/O pins must also be configured to correctly route the signal to the external pins.
- Select the frequency of the output signal by configuring the RTC Active Layer Frequency field in the Control B register (CTRLB.ACTF).

$$GCLK\_RTC\_OUT = \frac{CLK\_RTC}{2^{CTRLB.ACTF + 1}}$$

- Enable the tamper input n (INn) in Active Layer mode by writing 3 to the corresponding Input Action field in the Tamper Control register (TAMPCTRL.INnACT). When active layer protection is enabled and INn and OUT pin are used, the value of INn is sampled on the falling edge of CLK\_RTC and compared to the expected value of OUT. Therefore up to one half of a CLK\_RTC period is available for propagation delay through the trace.
- Enable Active Layer Protection by setting the CTRLB.RTCOUT bit.

The following sequence must be followed once the RTC enabled (CTRLA.ENABLE = 1):

- Wait for 10 RTC clock periods
- Clear the TAMPID register
- Clear the INTFLAG.TAMPER bit
- Clear the TAMPID register
- Do a dummy read of the TIMESTAMP register

## 23.7 Register Summary - Mode 0 - 32-Bit Counter

Offset	Name	Bit Pos.	7	6	5	4	3	2	1	0
0x00	CTRLA	7:0	MATCHCLR				MODE[1:0]		ENABLE	SWRST
		15:8	COUNTSYNC		BKTRST		PRESCALER[3:0]			
0x02	CTRLB	7:0	DMAEN	RTCOUT	DEBASync				GP2EN	GP0EN
		15:8			ACTF[2:0]			DEBF[2:0]		
0x04	EVCTRL	7:0	PEREO7	PEREO6	PEREO5	PEREO4	PEREO3	PEREO2	PEREO1	PEREO0
		15:8	OVFEO	TAMPEREO					CMPEO1	CMPEO0
		23:16								TAMPEVEI
		31:24								
0x08	INTENCLR	7:0	PER7	PER6	PER5	PER4	PER3	PER2	PER1	PER0
		15:8	OVF	TAMPER					CMP1	CMP0
0x0A	INTENSET	7:0	PER7	PER6	PER5	PER4	PER3	PER2	PER1	PER0
		15:8	OVF	TAMPER					CMP1	CMP0
0x0C	INTFLAG	7:0	PER7	PER6	PER5	PER4	PER3	PER2	PER1	PER0
		15:8	OVF	TAMPER					CMP1	CMP0
0x0E	DBGCTRL	7:0								DBGRUN
0x0F	Reserved									
0x10	SYNCBUSY	7:0		COMP1	COMP0		COUNT	FREQCORR	ENABLE	SWRST
		15:8	COUNTSYNC							
		23:16					GP3	GP2	GP1	GP0
		31:24								
0x14	FREQCORR	7:0	SIGN	VALUE[6:0]						
0x15 ... 0x17	Reserved									
0x18	COUNT	7:0	COUNT[7:0]							
		15:8	COUNT[15:8]							
		23:16	COUNT[23:16]							
		31:24	COUNT[31:24]							
0x1C ... 0x1F	Reserved									
0x20	COMP0	7:0	COMP[7:0]							
		15:8	COMP[15:8]							
		23:16	COMP[23:16]							
		31:24	COMP[31:24]							
0x24	COMP1	7:0	COMP[7:0]							
		15:8	COMP[15:8]							
		23:16	COMP[23:16]							
		31:24	COMP[31:24]							
0x28 ... 0x3F	Reserved									
0x40	GP0	7:0	GP[7:0]							
		15:8	GP[15:8]							
		23:16	GP[23:16]							
		31:24	GP[31:24]							
0x44	GP1	7:0	GP[7:0]							
		15:8	GP[15:8]							
		23:16	GP[23:16]							
		31:24	GP[31:24]							
0x48	GP2	7:0	GP[7:0]							
		15:8	GP[15:8]							
		23:16	GP[23:16]							
		31:24	GP[31:24]							
0x4C	GP3	7:0	GP[7:0]							
		15:8	GP[15:8]							
		23:16	GP[23:16]							
		31:24	GP[31:24]							

.....continued

Offset	Name	Bit Pos.	7	6	5	4	3	2	1	0
0x50 ... 0x5F	Reserved									
0x60	TAMPCTRL	7:0	IN3ACT[1:0]		IN2ACT[1:0]		IN1ACT[1:0]		IN0ACT[1:0]	
		15:8	IN4ACT[1:0]							
		23:16				TAMLVL4	TAMLVL3	TAMLVL2	TAMLVL1	TAMLVL0
		31:24				DEBNC4	DEBNC3	DEBNC2	DEBNC1	DEBNC0
0x64	TIMESTAMP	7:0	COUNT[7:0]							
		15:8	COUNT[15:8]							
		23:16	COUNT[23:16]							
		31:24	COUNT[31:24]							
0x68	TAMPID	7:0				TAMPID4	TAMPID3	TAMPID2	TAMPID1	TAMPID0
		15:8								
		23:16								
		31:24	TAMPEVT							
0x6C ... 0x7F	Reserved									
0x80	BKUP0	7:0	BKUP[7:0]							
		15:8	BKUP[15:8]							
		23:16	BKUP[23:16]							
		31:24	BKUP[31:24]							
0x84	BKUP1	7:0	BKUP[7:0]							
		15:8	BKUP[15:8]							
		23:16	BKUP[23:16]							
		31:24	BKUP[31:24]							
0x88	BKUP2	7:0	BKUP[7:0]							
		15:8	BKUP[15:8]							
		23:16	BKUP[23:16]							
		31:24	BKUP[31:24]							
0x8C	BKUP3	7:0	BKUP[7:0]							
		15:8	BKUP[15:8]							
		23:16	BKUP[23:16]							
		31:24	BKUP[31:24]							
0x90	BKUP4	7:0	BKUP[7:0]							
		15:8	BKUP[15:8]							
		23:16	BKUP[23:16]							
		31:24	BKUP[31:24]							
0x94	BKUP5	7:0	BKUP[7:0]							
		15:8	BKUP[15:8]							
		23:16	BKUP[23:16]							
		31:24	BKUP[31:24]							
0x98	BKUP6	7:0	BKUP[7:0]							
		15:8	BKUP[15:8]							
		23:16	BKUP[23:16]							
		31:24	BKUP[31:24]							
0x9C	BKUP7	7:0	BKUP[7:0]							
		15:8	BKUP[15:8]							
		23:16	BKUP[23:16]							
		31:24	BKUP[31:24]							

### 23.7.1 Control A in COUNT32 mode (CTRLA.MODE=0)

**Name:** CTRLA  
**Offset:** 0x00  
**Reset:** 0x0000  
**Property:** PAC Write-Protection, Enable-Protected Bits, Write-Synchronized Bits

Bit	15	14	13	12	11	10	9	8
	COUNTSYNC		BKTRST		PRESCALER[3:0]			
Access	R/W		R/W		R/W	R/W	R/W	R/W
Reset	0		0		0	0	0	0
Bit	7	6	5	4	3	2	1	0
	MATCHCLR				MODE[1:0]		ENABLE	SWRST
Access	R/W				R/W	R/W	R/W	R/W
Reset	0				0	0	0	0

#### Bit 15 – COUNTSYNC COUNT Read Synchronization Enable

The COUNT register requires synchronization when reading. Disabling the synchronization will prevent reading valid values from the COUNT register.

This bit is not enable-protected.

**Note:** For the first value read, read the COUNT register prior to enable the COUNT read synchronization (COUNTSYNC = 0). After enabling the COUNT read synchronization (COUNTSYNC = 1), read the COUNT register until its value is changed when compared to its first value read. All subsequent COUNT values are then valid.

Value	Description
0	COUNT read synchronization is disabled
1	COUNT read synchronization is enabled

#### Bit 13 – BKTRST BKUP Registers Reset On Tamper Enable

All BKUPn registers are affected. This bit can be written only when the peripheral is disabled.

This bit is not synchronized.

Value	Description
0	BKUPn registers will not reset when a tamper condition occurs.
1	BKUPn registers will reset when a tamper condition occurs.

#### Bits 11:8 – PRESCALER[3:0] Prescaler

These bits define the prescaling factor for the RTC clock source (GCLK\_RTC) to generate the counter clock (CLK\_RTC\_CNT). Periodic events and interrupts are not available when the prescaler is off.

These bits are not synchronized.

**Note:** When the tamper or debouncing features (TAMPCTRL) are enabled, periodic interrupts and events are generated even when the prescaler is OFF (CTRLA.PRESCALER = 0). In this specific situation, clear the Periodic Interval n Event Output Enable bits (EVCTRL.PEREOn = 0 [n = 7...0]) and respective Periodic Interval n Interrupt Enable (INTENCLR.PERn = 1 [n = 7...0]) bits.

Value	Name	Description
0x0	OFF	CLK_RTC_CNT = GCLK_RTC/1
0x1	DIV1	CLK_RTC_CNT = GCLK_RTC/1
0x2	DIV2	CLK_RTC_CNT = GCLK_RTC/2
0x3	DIV4	CLK_RTC_CNT = GCLK_RTC/4
0x4	DIV8	CLK_RTC_CNT = GCLK_RTC/8
0x5	DIV16	CLK_RTC_CNT = GCLK_RTC/16
0x6	DIV32	CLK_RTC_CNT = GCLK_RTC/32
0x7	DIV64	CLK_RTC_CNT = GCLK_RTC/64



Value	Name	Description
0x8	DIV128	CLK_RTC_CNT = GCLK_RTC/128
0x9	DIV256	CLK_RTC_CNT = GCLK_RTC/256
0xA	DIV512	CLK_RTC_CNT = GCLK_RTC/512
0xB	DIV1024	CLK_RTC_CNT = GCLK_RTC/1024
0xC-0xF	-	Reserved

#### Bit 7 - MATCHCLR Clear on Match

This bit defines if the counter is cleared or not on a match.  
This bit is not synchronized.

Value	Description
0	The counter is not cleared on a Compare/Alarm 0 match
1	The counter is cleared on a Compare/Alarm 0 match

#### Bits 3:2 - MODE[1:0] Operating Mode

This bit group defines the operating mode of the RTC.  
This bit is not synchronized.

Value	Name	Description
0x0	COUNT32	Mode 0: 32-bit counter
0x1	COUNT16	Mode 1: 16-bit counter
0x2	CLOCK	Mode 2: Clock/calendar
0x3	-	Reserved

#### Bit 1 - ENABLE Enable

Due to synchronization there is a delay between writing CTRLA.ENABLE and until the peripheral is enabled/disabled. The value written to CTRLA.ENABLE will read back immediately and the Enable bit in the Synchronization Busy register (SYNCBUSY.ENABLE) will be set. SYNCBUSY.ENABLE will be cleared when the operation is complete.

Value	Description
0	The peripheral is disabled
1	The peripheral is enabled

#### Bit 0 - SWRST Software Reset

Writing a '0' to this bit has no effect.

Writing a '1' to this bit resets all registers in the RTC (except DBGCTRL) to their initial state, and the RTC will be disabled.

Writing a '1' to CTRLA.SWRST will always take precedence, meaning that all other writes in the same write-operation will be discarded.

Due to synchronization there is a delay between writing CTRLA.SWRST and until the reset is complete. CTRLA.SWRST will be cleared when the reset is complete.

##### Notes:

1. When the CTRLA.SWRST is written, the user must poll the SYNCBUSY.SWRST bit to know when the reset operation is complete.
2. During a SWRST, access to registers/bits without the SWRST are disallowed until the SYNCBUSY.SWRST is cleared by hardware.

Value	Description
0	There is not reset operation ongoing
1	The reset operation is ongoing

### 23.7.2 Control B in COUNT32 mode (CTRLA.MODE=0)

**Name:** CTRLB  
**Offset:** 0x02  
**Reset:** 0x0000  
**Property:** PAC Write-Protection, Enable-Protected

Bit	15	14	13	12	11	10	9	8	
			ACTF[2:0]			DEBF[2:0]			
Access		R/W	R/W	R/W		R/W	R/W	R/W	
Reset		0	0	0		0	0	0	
Bit	7	6	5	4	3	2	1	0	
	DMAEN	RTCOUT	DEBASYNC					GP2EN	GPOEN
Access	R/W	R/W	R/W				R/W	R/W	
Reset	0	0	0				0	0	

#### Bits 14:12 – ACTF[2:0] Active Layer Frequency

These bits define the prescaling factor for the RTC clock output (OUT) used during active layer protection in terms of the CLK\_RTC.

Value	Name	Description
0x0	DIV2	CLK_RTC_OUT = CLK_RTC / 2
0x1	DIV4	CLK_RTC_OUT = CLK_RTC / 4
0x2	DIV8	CLK_RTC_OUT = CLK_RTC / 8
0x3	DIV16	CLK_RTC_OUT = CLK_RTC / 16
0x4	DIV32	CLK_RTC_OUT = CLK_RTC / 32
0x5	DIV64	CLK_RTC_OUT = CLK_RTC / 64
0x6	DIV128	CLK_RTC_OUT = CLK_RTC / 128
0x7	DIV256	CLK_RTC_OUT = CLK_RTC / 256

#### Bits 10:8 – DEBF[2:0] Debounce Frequency

These bits define the prescaling factor for the input debouncers in terms of the CLK\_RTC.

Value	Name	Description
0x0	DIV2	CLK_RTC_DEB = CLK_RTC / 2
0x1	DIV4	CLK_RTC_DEB = CLK_RTC / 4
0x2	DIV8	CLK_RTC_DEB = CLK_RTC / 8
0x3	DIV16	CLK_RTC_DEB = CLK_RTC / 16
0x4	DIV32	CLK_RTC_DEB = CLK_RTC / 32
0x5	DIV64	CLK_RTC_DEB = CLK_RTC / 64
0x6	DIV128	CLK_RTC_DEB = CLK_RTC / 128
0x7	DIV256	CLK_RTC_DEB = CLK_RTC / 256

#### Bit 7 – DMAEN DMA Enable

The RTC can trigger a DMA request when the timestamp is ready in the TIMESTAMP register.

Value	Description
0	Tamper DMA request is disabled. Reading TIMESTAMP has no effect on INTFLAG.TAMPER.
1	Tamper DMA request is enabled. Reading TIMESTAMP will clear INTFLAG.TAMPER.

#### Bit 6 – RTCOUT RTC Output Enable

Value	Description
0	The RTC active layer output is disabled.
1	The RTC active layer output is enabled.

#### Bit 5 – DEBASYNC Debouncer Asynchronous Enable

Value	Description
0	The tamper input debouncers operate synchronously.
1	The tamper input debouncers operate asynchronously.

**Bit 1 – GP2EN** General Purpose 2 Enable

Value	Description
0	COMP1 compare function enabled. GP2/GP3 disabled.
1	COMP1 compare function disabled. GP2/GP3 enabled.

**Bit 0 – GPOEN** General Purpose 0 Enable

Value	Description
0	COMP0 compare function enabled. GP0/GP1 disabled.
1	COMP0 compare function disabled. GP0/GP1 enabled.

### 23.7.3 Event Control in COUNT32 mode (CTRLA.MODE=0)

**Name:** EVCTRL  
**Offset:** 0x04  
**Reset:** 0x00000000  
**Property:** PAC Write-Protection, Enable-Protected

Bit	31	30	29	28	27	26	25	24
Access								
Reset								
Bit	23	22	21	20	19	18	17	16
Access								TAMPEVEI
Reset								R/W 0
Bit	15	14	13	12	11	10	9	8
Access	OVFEO	TAMPEREO					CMPEO1	CMPEO0
Reset	R/W 0	R/W 0					R/W 0	R/W 0
Bit	7	6	5	4	3	2	1	0
Access	PEREO7	PEREO6	PEREO5	PEREO4	PEREO3	PEREO2	PEREO1	PEREO0
Reset	R/W 0	R/W 0	R/W 0	R/W 0	R/W 0	R/W 0	R/W 0	R/W 0

#### Bit 16 – TAMPEVEI Tamper Event Input Enable

Value	Description
0	Tamper event input is disabled and incoming events will be ignored.
1	Tamper event input is enabled and incoming events will capture the COUNT value.

#### Bit 15 – OVFEO Overflow Event Output Enable

Value	Description
0	Overflow event is disabled and will not be generated.
1	Overflow event is enabled and will be generated for every overflow.

#### Bit 14 – TAMPEREO Tamper Event Output Enable

Value	Description
0	Tamper event output is disabled and will not be generated.
1	Tamper event output is enabled and will be generated for every tamper input.

#### Bits 8, 9 – CMPEOn Compare n Event Output Enable [n = 1..0]

Value	Description
0	Compare n event is disabled and will not be generated.
1	Compare n event is enabled and will be generated for every compare match.

#### Bits 0, 1, 2, 3, 4, 5, 6, 7 – PEREO<sub>n</sub> Periodic Interval n Event Output Enable [n = 7..0]

Value	Description
0	Periodic Interval n event is disabled and will not be generated.
1	Periodic Interval n event is enabled and will be generated.

### 23.7.4 Interrupt Enable Clear in COUNT32 mode (CTRLA.MODE=0)

**Name:** INTENCLR  
**Offset:** 0x08  
**Reset:** 0x0000  
**Property:** PAC Write-Protection

This register allows the user to disable an interrupt without doing a read-modify-write operation. Changes in this register will also be reflected in the Interrupt Enable Set (INTENSET) register.

Bit	15	14	13	12	11	10	9	8
	OVF	TAMPER					CMP1	CMP0
Access	R/W	R/W					R/W	R/W
Reset	0	0					0	0
Bit	7	6	5	4	3	2	1	0
	PER7	PER6	PER5	PER4	PER3	PER2	PER1	PER0
Access	R/W	R/W	R/W	R/W	R/W	R/W	R/W	R/W
Reset	0	0	0	0	0	0	0	0

#### Bit 15 – OVF Overflow Interrupt Enable

Writing a '0' to this bit has no effect.

Writing a '1' to this bit will clear the Overflow Interrupt Enable bit, which disables the Overflow interrupt.

Value	Description
0	The Overflow interrupt is disabled.
1	The Overflow interrupt is enabled.

#### Bit 14 – TAMPER Tamper Interrupt Enable

Writing a '0' to this bit has no effect.

Writing a '1' to this bit will clear the Tamper Interrupt Enable bit, which disables the Tamper interrupt.

Value	Description
0	The Tamper interrupt is disabled.
1	The Tamper interrupt is enabled.

#### Bits 8, 9 – CMPn Compare n Interrupt Enable [n = 1..0]

Writing a '0' to this bit has no effect.

Writing a '1' to this bit will clear the Compare n Interrupt Enable bit, which disables the Compare n interrupt.

Value	Description
0	The Compare n interrupt is disabled.
1	The Compare n interrupt is enabled.

#### Bits 0, 1, 2, 3, 4, 5, 6, 7 – PERn Periodic Interval n Interrupt Enable [n = 7..0]

Writing a '0' to this bit has no effect.

Writing a '1' to this bit will clear the Periodic Interval n Interrupt Enable bit, which disables the Periodic Interval n interrupt.

Value	Description
0	Periodic Interval n interrupt is disabled.
1	Periodic Interval n interrupt is enabled.

### 23.7.5 Interrupt Enable Set in COUNT32 mode (CTRLA.MODE=0)

**Name:** INTENSET  
**Offset:** 0x0A  
**Reset:** 0x0000  
**Property:** PAC Write-Protection

This register allows the user to enable an interrupt without doing a read-modify-write operation. Changes in this register will also be reflected in the Interrupt Enable Clear (INTENCLR) register.

Bit	15	14	13	12	11	10	9	8
	OVF	TAMPER					CMP1	CMP0
Access	R/W	R/W					R/W	R/W
Reset	0	0					0	0
Bit	7	6	5	4	3	2	1	0
	PER7	PER6	PER5	PER4	PER3	PER2	PER1	PER0
Access	R/W	R/W	R/W	R/W	R/W	R/W	R/W	R/W
Reset	0	0	0	0	0	0	0	0

#### Bit 15 – OVF Overflow Interrupt Enable

Writing a '0' to this bit has no effect.

Writing a '1' to this bit will set the Overflow Interrupt Enable bit, which enables the Overflow interrupt.

Value	Description
0	The Overflow interrupt is disabled.
1	The Overflow interrupt is enabled.

#### Bit 14 – TAMPER Tamper Interrupt Enable

Writing a '0' to this bit has no effect.

Writing a '1' to this bit will set the Tamper Interrupt Enable bit, which enables the Tamper interrupt.

Value	Description
0	The Tamper interrupt is disabled.
1	The Tamper interrupt is enabled.

#### Bits 8, 9 – CMPn Compare n Interrupt Enable [n = 1..0]

Writing a '0' to this bit has no effect.

Writing a '1' to this bit will set the Compare n Interrupt Enable bit, which and enables the Compare n interrupt.

Value	Description
0	The Compare n interrupt is disabled.
1	The Compare n interrupt is enabled.

#### Bits 0, 1, 2, 3, 4, 5, 6, 7 – PERn Periodic Interval n Interrupt Enable [n = 7..0]

Writing a '0' to this bit has no effect.

Writing a '1' to this bit will set the Periodic Interval n Interrupt Enable bit, which enables the Periodic Interval n interrupt.

Value	Description
0	Periodic Interval n interrupt is disabled.
1	Periodic Interval n interrupt is enabled.

### 23.7.6 Interrupt Flag Status and Clear in COUNT32 mode (CTRLA.MODE = 0)

**Name:** INTFLAG  
**Offset:** 0x0C  
**Reset:** 0x0000  
**Property:** -

Bit	15	14	13	12	11	10	9	8
	OVF	TAMPER					CMP1	CMP0
Access	R/W	R/W					R/W	R/W
Reset	0	0					0	0

Bit	7	6	5	4	3	2	1	0
	PER7	PER6	PER5	PER4	PER3	PER2	PER1	PER0
Access	R/W	R/W	R/W	R/W	R/W	R/W	R/W	R/W
Reset	0	0	0	0	0	0	0	0

#### Bit 15 – OVF Overflow

This flag is cleared by writing a '1' to the flag.

This flag is set on the next CLK\_RTC\_CNT cycle after an overflow condition occurs, and an interrupt request will be generated if INTENCLR/SET.OVF is '1'.

Writing a '0' to this bit has no effect.

Writing a '1' to this bit clears the Overflow interrupt flag.

#### Bit 14 – TAMPER Tamper event

This flag is set after a tamper condition occurs, and an interrupt request will be generated if INTENCLR.TAMPER/INTENSET.TAMPER is '1'. Writing a '0' to this bit has no effect. Writing a '1' to this bit clears the Tamper interrupt flag.

**Note:** Tamper interrupts must be ignored until 10 RTC clock periods after the RTC tamper detection is enabled.

#### Bits 8, 9 – CMPn Compare n [n = 1..0]

This flag is cleared by writing a '1' to the flag.

This flag is set on the next CLK\_RTC\_CNT cycle after a match with the compare condition, and an interrupt request will be generated if INTENCLR/SET.COMPn is one.

Writing a '0' to this bit has no effect.

Writing a '1' to this bit clears the Compare n interrupt flag.

#### Bits 0, 1, 2, 3, 4, 5, 6, 7 – PERn Periodic Interval n [n = 7..0]

This flag is cleared by writing a '1' to the flag.

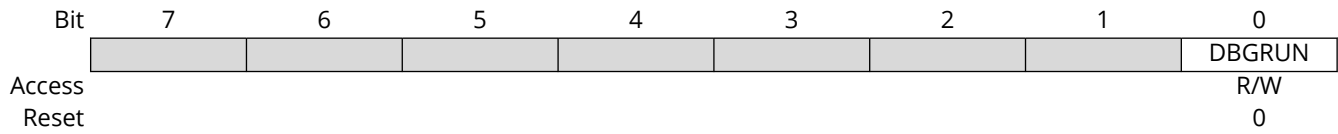
This flag is set on the 0-to-1 transition of prescaler bit [n+2], and an interrupt request will be generated if INTENCLR/SET.PERn is one.

Writing a '0' to this bit has no effect.

Writing a '1' to this bit clears the Periodic Interval n interrupt flag.

### 23.7.7 Debug Control

**Name:** DBGCTRL  
**Offset:** 0x0E  
**Reset:** 0x00  
**Property:** PAC Write-Protection



#### Bit 0 – DBGRUN Debug Run

This bit is not reset by a software reset.

This bit controls the functionality when the CPU is halted by an external debugger.

Value	Description
0	The RTC is halted when the CPU is halted by an external debugger.
1	The RTC continues normal operation when the CPU is halted by an external debugger.



### 23.7.8 Synchronization Busy in COUNT32 mode (CTRLA.MODE=0)

**Name:** SYNCBUSY  
**Offset:** 0x10  
**Reset:** 0x00000000  
**Property:** -

Bit	31	30	29	28	27	26	25	24
Access								
Reset								
Bit	23	22	21	20	19	18	17	16
Access					GP3	GP2	GP1	GP0
Reset					R	R	R	R
Bit	15	14	13	12	11	10	9	8
Access	COUNTSYNC							
Reset	R							
Bit	7	6	5	4	3	2	1	0
Access		COMP1	COMP0		COUNT	FREQCORR	ENABLE	SWRST
Reset		R	R		R	R	R	R
Bit	7	6	5	4	3	2	1	0
Reset		0	0		0	0	0	0

#### Bits 16, 17, 18, 19 – GPn General Purpose n Synchronization Busy Status

Value	Description
0	Write synchronization for GPn register is complete.
1	Write synchronization for GPn register is ongoing.

#### Bit 15 – COUNTSYNC Count Read Sync Enable Synchronization Busy Status

Value	Description
0	Write synchronization for CTRLA.COUNTSYNC bit is complete.
1	Write synchronization for CTRLA.COUNTSYNC bit is ongoing.

#### Bits 5, 6 – COMPn Compare n Synchronization Busy Status [n = 1..0]

Value	Description
0	Write synchronization for COMPx register is complete.
1	Write synchronization for COMPx register is ongoing.

#### Bit 3 – COUNT Count Value Synchronization Busy Status

Value	Description
0	Read/write synchronization for COUNT register is complete.
1	Read/write synchronization for COUNT register is ongoing.

#### Bit 2 – FREQCORR Frequency Correction Synchronization Busy Status

Value	Description
0	Write synchronization for FREQCORR register is complete.
1	Write synchronization for FREQCORR register is ongoing.

#### Bit 1 – ENABLE Enable Synchronization Busy Status

Value	Description
0	Write synchronization for CTRLA.ENABLE bit is complete.
1	Write synchronization for CTRLA.ENABLE bit is ongoing.

**Bit 0 – SWRST** Software Reset Synchronization Busy Status

Value	Description
0	Write synchronization for CTRLA.SWRST bit is complete.
1	Write synchronization for CTRLA.SWRST bit is ongoing.

### 23.7.9 Frequency Correction

**Name:** FREQCORR  
**Offset:** 0x14  
**Reset:** 0x00  
**Property:** PAC Write-Protection, Write-Synchronized

**Note:** This register is write-synchronized: SYNCBUSY.FREQCORR must be checked to ensure the FREQCORR register synchronization is complete.

Bit	7	6	5	4	3	2	1	0
	SIGN	VALUE[6:0]						
Access	R/W	R/W	R/W	R/W	R/W	R/W	R/W	R/W
Reset	0	0	0	0	0	0	0	0

#### Bit 7 – SIGN Correction Sign

Value	Description
0	The correction value is positive, i.e., frequency will be decreased.
1	The correction value is negative, i.e., frequency will be increased.

#### Bits 6:0 – VALUE[6:0] Correction Value

These bits define the amount of correction applied to the RTC prescaler.

Value	Description
0	Correction is disabled and the RTC frequency is unchanged.
1 – 127	The RTC frequency is adjusted according to the value.

### 23.7.10 Counter Value in COUNT32 mode (CTRLA.MODE = 0)

**Name:** COUNT  
**Offset:** 0x18  
**Reset:** 0x00000000  
**Property:** PAC Write-Protection, Write-Synchronized

**Notes:**

1. Prior to any read access, this register must be synchronized by the user by writing CTRLA.COUNTSYNC = 1.
2. This register is write-synchronized: SYNCBUSY.COUNT must be checked to ensure the COUNT register synchronization is complete.
3. This register must be written with a 32-bit write access.

Bit	31	30	29	28	27	26	25	24
	COUNT[31:24]							
Access	R/W	R/W	R/W	R/W	R/W	R/W	R/W	R/W
Reset	0	0	0	0	0	0	0	0
Bit	23	22	21	20	19	18	17	16
	COUNT[23:16]							
Access	R/W	R/W	R/W	R/W	R/W	R/W	R/W	R/W
Reset	0	0	0	0	0	0	0	0
Bit	15	14	13	12	11	10	9	8
	COUNT[15:8]							
Access	R/W	R/W	R/W	R/W	R/W	R/W	R/W	R/W
Reset	0	0	0	0	0	0	0	0
Bit	7	6	5	4	3	2	1	0
	COUNT[7:0]							
Access	R/W	R/W	R/W	R/W	R/W	R/W	R/W	R/W
Reset	0	0	0	0	0	0	0	0

**Bits 31:0 – COUNT[31:0] Counter Value**

These bits define the value of the 32-bit RTC counter in mode 0.

### 23.7.11 Compare n Value in COUNT32 mode (CTRLA.MODE=0)

**Name:** COMPn  
**Offset:** 0x20 + n\*0x04 [n=0..1]  
**Reset:** 0x00000000  
**Property:** PAC Write-Protection, Write-Synchronized

**Note:** This register is write-synchronized: SYNCBUSY.COMPn must be checked to ensure the COMPn register synchronization is complete.

Bit	31	30	29	28	27	26	25	24
	COMP[31:24]							
Access	R/W	R/W	R/W	R/W	R/W	R/W	R/W	R/W
Reset	0	0	0	0	0	0	0	0
Bit	23	22	21	20	19	18	17	16
	COMP[23:16]							
Access	R/W	R/W	R/W	R/W	R/W	R/W	R/W	R/W
Reset	0	0	0	0	0	0	0	0
Bit	15	14	13	12	11	10	9	8
	COMP[15:8]							
Access	R/W	R/W	R/W	R/W	R/W	R/W	R/W	R/W
Reset	0	0	0	0	0	0	0	0
Bit	7	6	5	4	3	2	1	0
	COMP[7:0]							
Access	R/W	R/W	R/W	R/W	R/W	R/W	R/W	R/W
Reset	0	0	0	0	0	0	0	0

#### Bits 31:0 – COMP[31:0] Compare Value

The 32-bit value of COMPn is continuously compared with the 32-bit COUNT value. When a match occurs, the Compare n interrupt flag in the Interrupt Flag Status and Clear register (INTFLAG.CMPn) is set on the next counter cycle, and the counter value is cleared if CTRLA.MATCHCLR is one.

### 23.7.12 General Purpose n

**Name:** GPn  
**Offset:** 0x40 + n\*0x04 [n=0..3]  
**Reset:** 0x00000000  
**Property:** -

Bit	31	30	29	28	27	26	25	24
	GP[31:24]							
Access	R/W	R/W	R/W	R/W	R/W	R/W	R/W	R/W
Reset	0	0	0	0	0	0	0	0
Bit	23	22	21	20	19	18	17	16
	GP[23:16]							
Access	R/W	R/W	R/W	R/W	R/W	R/W	R/W	R/W
Reset	0	0	0	0	0	0	0	0
Bit	15	14	13	12	11	10	9	8
	GP[15:8]							
Access	R/W	R/W	R/W	R/W	R/W	R/W	R/W	R/W
Reset	0	0	0	0	0	0	0	0
Bit	7	6	5	4	3	2	1	0
	GP[7:0]							
Access	R/W	R/W	R/W	R/W	R/W	R/W	R/W	R/W
Reset	0	0	0	0	0	0	0	0

#### Bits 31:0 – GP[31:0] General Purpose

These bits are for user-defined general purpose use, see [23.6.8.4. General Purpose Registers](#).

### 23.7.13 Tamper Control

**Name:** TAMPCTRL  
**Offset:** 0x60  
**Reset:** 0x00000000  
**Property:** PAC Write-Protection, Enable-Protected

Bit	31	30	29	28	27	26	25	24
				DEBNC4	DEBNC3	DEBNC2	DEBNC1	DEBNC0
Access								
Reset				0	0	0	0	0
Bit	23	22	21	20	19	18	17	16
				TAMLVL4	TAMLVL3	TAMLVL2	TAMLVL1	TAMLVL0
Access								
Reset				0	0	0	0	0
Bit	15	14	13	12	11	10	9	8
							IN4ACT[1:0]	
Access								
Reset							0	0
Bit	7	6	5	4	3	2	1	0
	IN3ACT[1:0]		IN2ACT[1:0]		IN1ACT[1:0]		IN0ACT[1:0]	
Access								
Reset	0	0	0	0	0	0	0	0

**Bits 24, 25, 26, 27, 28 – DEBNCn** Debounce Enable of Tamper Input INn [n=0..3]

**Note:** Debounce feature does not apply to the Active Layer Protection mode (TAMPCTRL.INACT = ACTL).

Value	Description
0	Debouncing is disabled for Tamper input INn
1	Debouncing is enabled for Tamper input INn

**Bits 16, 17, 18, 19, 20 – TAMLVLn** Tamper Level Select of Tamper Input INn [n=0..3]

**Note:** Tamper Level feature does not apply to the Active Layer Protection mode (TAMPCTRL.INACT = ACTL).

Value	Description
0	A falling edge condition will be detected on Tamper input INn.
1	A rising edge condition will be detected on Tamper input INn.

**Bits 0:1, 2:3, 4:5, 6:7, 8:9 – INnACT** Tamper Channel n Action [n=0..3]

These bits determine the action taken by Tamper Channel n.

Value	Name	Description
0x0	OFF	Off (Disabled)
0x1	WAKE	Wake and set Tamper flag
0x2	CAPTURE	Capture timestamp and set Tamper flag
0x3	ACTL	Compare RTC signal routed between INn and OUT pins . When a mismatch occurs, capture timestamp and set Tamper flag

### 23.7.14 Timestamp

**Name:**       TIMESTAMP  
**Offset:**     0x64  
**Reset:**       0x0  
**Property:**   -

Bit	31	30	29	28	27	26	25	24
	COUNT[31:24]							
Access	R	R	R	R	R	R	R	R
Reset	0	0	0	0	0	0	0	0
Bit	23	22	21	20	19	18	17	16
	COUNT[23:16]							
Access	R	R	R	R	R	R	R	R
Reset	0	0	0	0	0	0	0	0
Bit	15	14	13	12	11	10	9	8
	COUNT[15:8]							
Access	R	R	R	R	R	R	R	R
Reset	0	0	0	0	0	0	0	0
Bit	7	6	5	4	3	2	1	0
	COUNT[7:0]							
Access	R	R	R	R	R	R	R	R
Reset	0	0	0	0	0	0	0	0

#### Bits 31:0 – COUNT[31:0] Count Timestamp Value

The 32-bit value of COUNT is captured by the TIMESTAMP when a tamper condition occurs



### 23.7.15 Tamper ID

**Name:** TAMPID  
**Offset:** 0x68  
**Reset:** 0x00000000

Bit	31	30	29	28	27	26	25	24
	TAMPEVT							
Access	R/W							
Reset	0							
Bit	23	22	21	20	19	18	17	16
Access								
Reset								
Bit	15	14	13	12	11	10	9	8
Access								
Reset								
Bit	7	6	5	4	3	2	1	0
				TAMPID4	TAMPID3	TAMPID2	TAMPID1	TAMPID0
Access				R/W	R/W	R/W	R/W	R/W
Reset				0	0	0	0	0

#### Bit 31 – TAMPEVT Tamper Event Detected

Writing a '0' to this bit has no effect. Writing a '1' to this bit clears the tamper detection bit.

Value	Description
0	A tamper input event has not been detected
1	A tamper input event has been detected

#### Bits 0, 1, 2, 3, 4 – TAMPIDn Tamper on Channel n Detected [n=0..3]

Writing a '0' to this bit has no effect. Writing a '1' to this bit clears the tamper detection bit.

Value	Description
0	A tamper condition has not been detected on Channel n
1	A tamper condition has been detected on Channel n

### 23.7.16 Backup n

**Name:** BKUP  
**Offset:** 0x80 + n\*0x04 [n=0..7]  
**Reset:** 0x00000000  
**Property:** PAC Write-Protection

Bit	31	30	29	28	27	26	25	24
	BKUP[31:24]							
Access	R/W	R/W	R/W	R/W	R/W	R/W	R/W	R/W
Reset	0	0	0	0	0	0	0	0
Bit	23	22	21	20	19	18	17	16
	BKUP[23:16]							
Access	R/W	R/W	R/W	R/W	R/W	R/W	R/W	R/W
Reset	0	0	0	0	0	0	0	0
Bit	15	14	13	12	11	10	9	8
	BKUP[15:8]							
Access	R/W	R/W	R/W	R/W	R/W	R/W	R/W	R/W
Reset	0	0	0	0	0	0	0	0
Bit	7	6	5	4	3	2	1	0
	BKUP[7:0]							
Access	R/W	R/W	R/W	R/W	R/W	R/W	R/W	R/W
Reset	0	0	0	0	0	0	0	0

#### Bits 31:0 – BKUP[31:0] Backup

These bits are user-defined for general purpose use in the Backup domain.

## 23.8 Register Summary - Mode 1 - 16-Bit Counter

Offset	Name	Bit Pos.	7	6	5	4	3	2	1	0
0x00	CTRLA	7:0					MODE[1:0]		ENABLE	SWRST
		15:8	COUNTSYNC		BKTRST		PRESCALER[3:0]			
0x02	CTRLB	7:0	DMAEN	RTCOUT	DEBASync				GP2EN	GP0EN
		15:8			ACTF[2:0]			DEBF[2:0]		
0x04	EVCTRL	7:0	PEREO7	PEREO6	PEREO5	PEREO4	PEREO3	PEREO2	PEREO1	PEREO0
		15:8	OVFEO	TAMPERO			CMPEO3	CMPEO2	CMPEO1	CMPEO0
		23:16								TAMPEVEI
		31:24								
0x08	INTENCLR	7:0	PER7	PER6	PER5	PER4	PER3	PER2	PER1	PER0
		15:8	OVF	TAMPER			CMP3	CMP2	CMP1	CMP0
0x0A	INTENSET	7:0	PER7	PER6	PER5	PER4	PER3	PER2	PER1	PER0
		15:8	OVF	TAMPER			CMP3	CMP2	CMP1	CMP0
0x0C	INTFLAG	7:0	PER7	PER6	PER5	PER4	PER3	PER2	PER1	PER0
		15:8	OVF	TAMPER			CMP3	CMP2	CMP1	CMP0
0x0E	DBGCTRL	7:0								DBGRUN
0x0F	Reserved									
0x10	SYNCBUSY	7:0	COMP2	COMP1	COMP0	PER	COUNT	FREQCORR	ENABLE	SWRST
		15:8	COUNTSYNC							COMP3
		23:16					GP3	GP2	GP1	GP0
		31:24								
0x14	FREQCORR	7:0	SIGN	VALUE[6:0]						
0x15 ... 0x17	Reserved									
0x18	COUNT	7:0	COUNT[7:0]							
		15:8	COUNT[15:8]							
0x1A ... 0x1B	Reserved									
0x1C	PER	7:0	PER[7:0]							
		15:8	PER[15:8]							
0x1E ... 0x1F	Reserved									
0x20	COMP0	7:0	COMP[7:0]							
		15:8	COMP[15:8]							
0x22	COMP1	7:0	COMP[7:0]							
		15:8	COMP[15:8]							
0x24	COMP2	7:0	COMP[7:0]							
		15:8	COMP[15:8]							
0x26	COMP3	7:0	COMP[7:0]							
		15:8	COMP[15:8]							
0x28 ... 0x3F	Reserved									
0x40	GP0	7:0	GP[7:0]							
		15:8	GP[15:8]							
		23:16	GP[23:16]							
		31:24	GP[31:24]							
0x44	GP1	7:0	GP[7:0]							
		15:8	GP[15:8]							
		23:16	GP[23:16]							
0x48	GP2	7:0	GP[7:0]							
		15:8	GP[15:8]							
		23:16	GP[23:16]							
		31:24	GP[31:24]							

.....continued											
Offset	Name	Bit Pos.	7	6	5	4	3	2	1	0	
0x4C	GP3	7:0	GP[7:0]								
		15:8	GP[15:8]								
		23:16	GP[23:16]								
		31:24	GP[31:24]								
0x50 ... 0x5F	Reserved										
0x60	TAMPCTRL	7:0	IN3ACT[1:0]		IN2ACT[1:0]		IN1ACT[1:0]		IN0ACT[1:0]		
		15:8	IN4ACT[1:0]								
		23:16			TAMLVL4	TAMLVL3	TAMLVL2	TAMLVL1	TAMLVL0		
		31:24			DEBNC4	DEBNC3	DEBNC2	DEBNC1	DEBNC0		
0x64	TIMESTAMP	7:0	COUNT[7:0]								
		15:8	COUNT[15:8]								
		23:16									
		31:24									
0x68	TAMPID	7:0			TAMPID4	TAMPID3	TAMPID2	TAMPID1	TAMPID0		
		15:8									
		23:16									
		31:24	TAMPEVT								
0x6C ... 0x7F	Reserved										
0x80	BKUP0	7:0	BKUP[7:0]								
		15:8	BKUP[15:8]								
		23:16	BKUP[23:16]								
		31:24	BKUP[31:24]								
0x84	BKUP1	7:0	BKUP[7:0]								
		15:8	BKUP[15:8]								
		23:16	BKUP[23:16]								
		31:24	BKUP[31:24]								
0x88	BKUP2	7:0	BKUP[7:0]								
		15:8	BKUP[15:8]								
		23:16	BKUP[23:16]								
		31:24	BKUP[31:24]								
0x8C	BKUP3	7:0	BKUP[7:0]								
		15:8	BKUP[15:8]								
		23:16	BKUP[23:16]								
		31:24	BKUP[31:24]								
0x90	BKUP4	7:0	BKUP[7:0]								
		15:8	BKUP[15:8]								
		23:16	BKUP[23:16]								
		31:24	BKUP[31:24]								
0x94	BKUP5	7:0	BKUP[7:0]								
		15:8	BKUP[15:8]								
		23:16	BKUP[23:16]								
		31:24	BKUP[31:24]								
0x98	BKUP6	7:0	BKUP[7:0]								
		15:8	BKUP[15:8]								
		23:16	BKUP[23:16]								
		31:24	BKUP[31:24]								
0x9C	BKUP7	7:0	BKUP[7:0]								
		15:8	BKUP[15:8]								
		23:16	BKUP[23:16]								
		31:24	BKUP[31:24]								

### 23.8.1 Control A in COUNT16 mode (CTRLA.MODE = 1)

**Name:** CTRLA  
**Offset:** 0x00  
**Reset:** 0x0000  
**Property:** PAC Write-Protection, Enable-Protected Bits, Write-Synchronized Bits

Bit	15	14	13	12	11	10	9	8
	COUNTSYNC		BKTRST		PRESCALER[3:0]			
Access	R/W		R/W		R/W	R/W	R/W	R/W
Reset	0		0		0	0	0	0
Bit	7	6	5	4	3	2	1	0
					MODE[1:0]		ENABLE	SWRST
Access					R/W	R/W	R/W	R/W
Reset					0	0	0	0

#### Bit 15 – COUNTSYNC COUNT Read Synchronization Enable

The COUNT register requires synchronization when reading. Disabling the synchronization will prevent reading valid values from the COUNT register.

This bit is not enable-protected.

**Note:** For the first value read, read the COUNT register prior to enable the COUNT read synchronization (COUNTSYNC = 0). After enabling the COUNT read synchronization (COUNTSYNC = 1), read the COUNT register until its value is changed when compared to its first value read. All subsequent COUNT values are then valid.

Value	Description
0	COUNT read synchronization is disabled
1	COUNT read synchronization is enabled

#### Bit 13 – BKTRST BKUP Registers Reset On Tamper Enable

All BKUPn registers are affected. This bit can be written only when the peripheral is disabled.

This bit is not synchronized.

Value	Description
0	BKUPn registers will not reset when a tamper condition occurs.
1	BKUPn registers will reset when a tamper condition occurs.

#### Bits 11:8 – PRESCALER[3:0] Prescaler

These bits define the prescaling factor for the RTC clock source (GCLK\_RTC) to generate the counter clock (CLK\_RTC\_CNT). Periodic events and interrupts are not available when the prescaler is off.

These bits are not synchronized.

Value	Name	Description
0x0	OFF	CLK_RTC_CNT = GCLK_RTC/1
0x1	DIV1	CLK_RTC_CNT = GCLK_RTC/1
0x2	DIV2	CLK_RTC_CNT = GCLK_RTC/2
0x3	DIV4	CLK_RTC_CNT = GCLK_RTC/4
0x4	DIV8	CLK_RTC_CNT = GCLK_RTC/8
0x5	DIV16	CLK_RTC_CNT = GCLK_RTC/16
0x6	DIV32	CLK_RTC_CNT = GCLK_RTC/32
0x7	DIV64	CLK_RTC_CNT = GCLK_RTC/64
0x8	DIV128	CLK_RTC_CNT = GCLK_RTC/128
0x9	DIV256	CLK_RTC_CNT = GCLK_RTC/256
0xA	DIV512	CLK_RTC_CNT = GCLK_RTC/512
0xB	DIV1024	CLK_RTC_CNT = GCLK_RTC/1024
0xC–0xF	-	Reserved

### Bits 3:2 – MODE[1:0] Operating Mode

This field defines the operating mode of the RTC. This bit is not synchronized.

Value	Name	Description
0x0	COUNT32	Mode 0: 32-bit counter
0x1	COUNT16	Mode 1: 16-bit counter
0x2	CLOCK	Mode 2: Clock/calendar
0x3	-	Reserved

### Bit 1 – ENABLE Enable

Due to synchronization there is delay from writing CTRLA.ENABLE until the peripheral is enabled/disabled. The value written to CTRLA.ENABLE will read back immediately and the Enable bit in the Synchronization Busy register (SYNCBUSY.ENABLE) will be set. SYNCBUSY.ENABLE will be cleared when the operation is complete.

Value	Description
0	The peripheral is disabled
1	The peripheral is enabled

### Bit 0 – SWRST Software Reset

Writing a '0' to this bit has no effect.

Writing a '1' to this bit resets all registers in the RTC (except DBGCTRL) to their initial state, and the RTC will be disabled.

Writing a '1' to CTRLA.SWRST will always take precedence, meaning that all other writes in the same write-operation will be discarded.

Due to synchronization there is a delay from writing CTRLA.SWRST until the reset is complete. CTRLA.SWRST will be cleared when the reset is complete.

#### Notes:

1. When the CTRLA.SWRST is written, the user must poll the SYNCBUSY.SWRST bit to know when the reset operation is complete.
2. During a SWRST, access to registers/bits without the SWRST are disallowed until the SYNCBUSY.SWRST is cleared by hardware.

Value	Description
0	There is not reset operation ongoing
1	The reset operation is ongoing

## 23.8.2 Control B in COUNT16 mode (CTRLA.MODE=1)

**Name:** CTRLB  
**Offset:** 0x02  
**Reset:** 0x0000  
**Property:** PAC Write-Protection, Enable-Protected

Bit	15	14	13	12	11	10	9	8	
			ACTF[2:0]					DEBF[2:0]	
Access		R/W	R/W	R/W		R/W	R/W	R/W	
Reset		0	0	0		0	0	0	
Bit	7	6	5	4	3	2	1	0	
	DMAEN	RTCOUT	DEBASYN					GP2EN	GPOEN
Access	R/W	R/W	R/W				R/W	R/W	
Reset	0	0	0				0	0	

### Bits 14:12 – ACTF[2:0] Active Layer Frequency

These bits define the prescaling factor for the RTC clock output (OUT) used during active layer protection in terms of the CLK\_RTC.

Value	Name	Description
0x0	DIV2	CLK_RTC_OUT = CLK_RTC / 2
0x1	DIV4	CLK_RTC_OUT = CLK_RTC / 4
0x2	DIV8	CLK_RTC_OUT = CLK_RTC / 8
0x3	DIV16	CLK_RTC_OUT = CLK_RTC / 16
0x4	DIV32	CLK_RTC_OUT = CLK_RTC / 32
0x5	DIV64	CLK_RTC_OUT = CLK_RTC / 64
0x6	DIV128	CLK_RTC_OUT = CLK_RTC / 128
0x7	DIV256	CLK_RTC_OUT = CLK_RTC / 256

### Bits 10:8 – DEBF[2:0] Debounce Frequency

These bits define the prescaling factor for the input debouncers in terms of the CLK\_RTC.

Value	Name	Description
0x0	DIV2	CLK_RTC_DEB = CLK_RTC / 2
0x1	DIV4	CLK_RTC_DEB = CLK_RTC / 4
0x2	DIV8	CLK_RTC_DEB = CLK_RTC / 8
0x3	DIV16	CLK_RTC_DEB = CLK_RTC / 16
0x4	DIV32	CLK_RTC_DEB = CLK_RTC / 32
0x5	DIV64	CLK_RTC_DEB = CLK_RTC / 64
0x6	DIV128	CLK_RTC_DEB = CLK_RTC / 128
0x7	DIV256	CLK_RTC_DEB = CLK_RTC / 256

### Bit 7 – DMAEN DMA Enable

The RTC can trigger a DMA request when the timestamp is ready in the TIMESTAMP register.

Value	Description
0	Tamper DMA request is disabled. Reading TIMESTAMP has no effect on INTFLAG.TAMPER.
1	Tamper DMA request is enabled. Reading TIMESTAMP will clear INTFLAG.TAMPER.

### Bit 6 – RTCOUT RTC Output Enable

Value	Description
0	The RTC active layer output is disabled.
1	The RTC active layer output is enabled.

### Bit 5 – DEBASYN Debouncer Asynchronous Enable

Value	Description
0	The tamper input debouncers operate synchronously.
1	The tamper input debouncers operate asynchronously.

**Bit 1 – GP2EN** General Purpose 2 Enable

Value	Description
0	COMP1 compare function enabled. GP2/GP3 disabled.
1	COMP1 compare function disabled. GP2/GP3 enabled.

**Bit 0 – GPOEN** General Purpose 0 Enable

Value	Description
0	COMP0 compare function enabled. GP0/GP1 disabled.
1	COMP0 compare function disabled. GP0/GP1 enabled.



### 23.8.3 Event Control in COUNT16 mode (CTRLA.MODE=1)

**Name:** EVCTRL  
**Offset:** 0x04  
**Reset:** 0x00000000  
**Property:** PAC Write-Protection, Enable-Protected

Bit	31	30	29	28	27	26	25	24
Access								
Reset								
Bit	23	22	21	20	19	18	17	16
Access								TAMPEVEI
Reset								R/W 0
Bit	15	14	13	12	11	10	9	8
Access	OVFEO	TAMPEREO			CMPEO3	CMPEO2	CMPEO1	CMPEO0
Reset	R/W 0	R/W 0			R/W 0	R/W 0	R/W 0	R/W 0
Bit	7	6	5	4	3	2	1	0
Access	PEREO7	PEREO6	PEREO5	PEREO4	PEREO3	PEREO2	PEREO1	PEREO0
Reset	R/W 0	R/W 0	R/W 0	R/W 0	R/W 0	R/W 0	R/W 0	R/W 0

#### Bit 16 – TAMPEVEI Tamper Event Input Enable

Value	Description
0	Tamper event input is disabled, and incoming events will be ignored
1	Tamper event input is enabled, and incoming events will capture the COUNT value

#### Bit 15 – OVFEO Overflow Event Output Enable

Value	Description
0	Overflow event is disabled and will not be generated.
1	Overflow event is enabled and will be generated for every overflow.

#### Bit 14 – TAMPEREO Tamper Event Output Enable

Value	Description
0	Tamper event output is disabled, and will not be generated.
1	Tamper event output is enabled, and will be generated for every tamper input.

#### Bits 8, 9, 10, 11 – CMPEOn Compare n Event Output Enable [n = 3..0]

Value	Description
0	Compare n event is disabled and will not be generated.
1	Compare n event is enabled and will be generated for every compare match.

#### Bits 0, 1, 2, 3, 4, 5, 6, 7 – PEREO<sub>n</sub> Periodic Interval n Event Output Enable [n = 7..0]

Value	Description
0	Periodic Interval n event is disabled and will not be generated.
1	Periodic Interval n event is enabled and will be generated.

### 23.8.4 Interrupt Enable Clear in COUNT16 mode (CTRLA.MODE=1)

**Name:** INTENCLR  
**Offset:** 0x08  
**Reset:** 0x0000  
**Property:** PAC Write-Protection

This register allows the user to disable an interrupt without doing a read-modify-write operation. Changes in this register will also be reflected in the Interrupt Enable Set (INTENSET) register.

Bit	15	14	13	12	11	10	9	8
	OVF	TAMPER			CMP3	CMP2	CMP1	CMP0
Access	R/W	R/W			R/W	R/W	R/W	R/W
Reset	0	0			0	0	0	0
Bit	7	6	5	4	3	2	1	0
	PER7	PER6	PER5	PER4	PER3	PER2	PER1	PER0
Access	R/W	R/W	R/W	R/W	R/W	R/W	R/W	R/W
Reset	0	0	0	0	0	0	0	0

#### Bit 15 – OVF Overflow Interrupt Enable

Writing a '0' to this bit has no effect. Writing a '1' to this bit will clear the Overflow Interrupt Enable bit, which disables the Overflow interrupt.

Value	Description
0	The Overflow interrupt is disabled.
1	The Overflow interrupt is enabled.

#### Bit 14 – TAMPER Tamper Interrupt Enable

Writing a '0' to this bit has no effect. Writing a '1' to this bit will clear the Tamper Interrupt Enable bit, which disables the Tamper interrupt.

Value	Description
0	The Tamper interrupt is disabled.
1	The Tamper interrupt is enabled.

#### Bits 8, 9, 10, 11 – CMPn Compare n Interrupt Enable [n = 3..0]

Writing a '0' to this bit has no effect. Writing a '1' to this bit will clear the Compare n Interrupt Enable bit, which disables the Compare n interrupt.

Value	Description
0	The Compare n interrupt is disabled.
1	The Compare n interrupt is enabled.

#### Bits 0, 1, 2, 3, 4, 5, 6, 7 – PERn Periodic Interval n Interrupt Enable [n = 7..0]

Writing a '0' to this bit has no effect. Writing a '1' to this bit will clear the Periodic Interval n Interrupt Enable bit, which disables the Periodic Interval n interrupt.

Value	Description
0	Periodic Interval n interrupt is disabled.
1	Periodic Interval n interrupt is enabled.

### 23.8.5 Interrupt Enable Set in COUNT16 mode (CTRLA.MODE=1)

**Name:** INTENSET  
**Offset:** 0x0A  
**Reset:** 0x0000  
**Property:** PAC Write-Protection

This register allows the user to enable an interrupt without doing a read-modify-write operation. Changes in this register will also be reflected in the Interrupt Enable Clear (INTENCLR) register.

Bit	15	14	13	12	11	10	9	8
	OVF	TAMPER			CMP3	CMP2	CMP1	CMP0
Access	R/W	R/W			R/W	R/W	R/W	R/W
Reset	0	0			0	0	0	0
Bit	7	6	5	4	3	2	1	0
	PER7	PER6	PER5	PER4	PER3	PER2	PER1	PER0
Access	R/W	R/W	R/W	R/W	R/W	R/W	R/W	R/W
Reset	0	0	0	0	0	0	0	0

#### Bit 15 – OVF Overflow Interrupt Enable

Writing a '0' to this bit has no effect. Writing a '1' to this bit will set the Overflow Interrupt Enable bit, which enables the Overflow interrupt.

Value	Description
0	The Overflow interrupt is disabled.
1	The Overflow interrupt is enabled.

#### Bit 14 – TAMPER Tamper Interrupt Enable

Writing a '0' to this bit has no effect. Writing a '1' to this bit will set the Tamper Interrupt Enable bit, which enables the Tamper interrupt.

Value	Description
0	The Tamper interrupt is disabled.
1	The Tamper interrupt is enabled.

#### Bits 8, 9, 10, 11 – CMPn Compare n Interrupt Enable [n = 3..0]

Writing a '0' to this bit has no effect. Writing a '1' to this bit will set the Compare n Interrupt Enable bit, which and enables the Compare n interrupt.

Value	Description
0	The Compare n interrupt is disabled.
1	The Compare n interrupt is enabled.

#### Bits 0, 1, 2, 3, 4, 5, 6, 7 – PERn Periodic Interval n Interrupt Enable [n = 7..0]

Writing a '0' to this bit has no effect. Writing a '1' to this bit will set the Periodic Interval n Interrupt Enable bit, which enables the Periodic Interval n interrupt.

Value	Description
0	Periodic Interval n interrupt is disabled.
1	Periodic Interval n interrupt is enabled.

## 23.8.6 Interrupt Flag Status and Clear in COUNT16 mode (CTRLA.MODE=1)

**Name:** INTFLAG  
**Offset:** 0x0C  
**Reset:** 0x0000  
**Property:** -

Bit	15	14	13	12	11	10	9	8
	OVF	TAMPER			CMP3	CMP2	CMP1	CMP0
Access	R/W	R/W			R/W	R/W	R/W	R/W
Reset	0	0			0	0	0	0

Bit	7	6	5	4	3	2	1	0
	PER7	PER6	PER5	PER4	PER3	PER2	PER1	PER0
Access	R/W	R/W	R/W	R/W	R/W	R/W	R/W	R/W
Reset	0	0	0	0	0	0	0	0

### Bit 15 – OVF Overflow

This flag is cleared by writing a '1' to the flag.

This flag is set on the next CLK\_RTC\_CNT cycle after an overflow condition occurs, and an interrupt request will be generated if INTENCLR/SET.OVF is '1'.

Writing a '0' to this bit has no effect.

Writing a '1' to this bit clears the Overflow interrupt flag.

### Bit 14 – TAMPER Tamper

This flag is set after a tamper condition occurs, and an interrupt request will be generated if INTENCLR.TAMPER/ INTENSET.TAMPER is one.

Writing a '0' to this bit has no effect.

Writing a one to this bit clears the Tamper interrupt flag.

### Bits 8, 9, 10, 11 – CMPn Compare n [n = 3..0]

This flag is cleared by writing a '1' to the flag.

This flag is set on the next CLK\_RTC\_CNT cycle after a match with the compare condition, and an interrupt request will be generated if INTENCLR/SET.COMPn is one.

Writing a '0' to this bit has no effect.

Writing a '1' to this bit clears the Compare n interrupt flag.

### Bits 0, 1, 2, 3, 4, 5, 6, 7 – PERn Periodic Interval n [n = 7..0]

This flag is cleared by writing a '1' to the flag.

This flag is set on the 0-to-1 transition of prescaler bit [n+2], and an interrupt request will be generated if INTENCLR/SET.PERx is one.

Writing a '0' to this bit has no effect.

Writing a '1' to this bit clears the Periodic Interval n interrupt flag.

### 23.8.7 Debug Control

**Name:** DBGCTRL  
**Offset:** 0x0E  
**Reset:** 0x00  
**Property:** PAC Write-Protection

Bit	7	6	5	4	3	2	1	0
								DBGRUN
Access								R/W
Reset								0

#### Bit 0 – DBGRUN Debug Run

This bit is not reset by a software reset.

This bit controls the functionality when the CPU is halted by an external debugger.

Value	Description
0	The RTC is halted when the CPU is halted by an external debugger.
1	The RTC continues normal operation when the CPU is halted by an external debugger.

### 23.8.8 Synchronization Busy in COUNT16 mode (CTRLA.MODE=1)

**Name:** SYNCBUSY  
**Offset:** 0x10  
**Reset:** 0x00000000  
**Property:** -

Bit	31	30	29	28	27	26	25	24
Access								
Reset								
Bit	23	22	21	20	19	18	17	16
Access					GP3	GP2	GP1	GP0
Reset					R	R	R	R
Reset					0	0	0	0
Bit	15	14	13	12	11	10	9	8
Access	COUNTSYNC							COMP3
Reset	R							R
Reset	0							0
Bit	7	6	5	4	3	2	1	0
Access	COMP2	COMP1	COMP0	PER	COUNT	FREQCORR	ENABLE	SWRST
Reset	R	R	R	R	R	R	R	R
Reset	0	0	0	0	0	0	0	0

#### Bits 16, 17, 18, 19 – GPn General Purpose n Synchronization Busy Status

Value	Description
0	Write synchronization for GPn register is complete.
1	Write synchronization for GPn register is ongoing.

#### Bit 15 – COUNTSYNC Count Read Sync Enable Synchronization Busy Status

Value	Description
0	Write synchronization for CTRLA.COUNTSYNC bit is complete.
1	Write synchronization for CTRLA.COUNTSYNC bit is ongoing.

#### Bits 5, 6, 7, 8 – COMPn Compare n Synchronization Busy Status [n = 3..0]

Value	Description
0	Write synchronization for COMPn register is complete.
1	Write synchronization for COMPn register is ongoing.

#### Bit 4 – PER Period Synchronization Busy Status

Value	Description
0	Write synchronization for PER register is complete.
1	Write synchronization for PER register is ongoing.

#### Bit 3 – COUNT Count Value Synchronization Busy Status

Value	Description
0	Read/write synchronization for COUNT register is complete.
1	Read/write synchronization for COUNT register is ongoing.

#### Bit 2 – FREQCORR Frequency Correction Synchronization Busy Status

Value	Description
0	Write synchronization for FREQCORR register is complete.
1	Write synchronization for FREQCORR register is ongoing.

**Bit 1 – ENABLE** Enable Synchronization Busy Status

Value	Description
0	Write synchronization for CTRLA.ENABLE bit is complete.
1	Write synchronization for CTRLA.ENABLE bit is ongoing.

**Bit 0 – SWRST** Software Reset Synchronization Busy Status

Value	Description
0	Write synchronization for CTRLA.SWRST bit is complete.
1	Write synchronization for CTRLA.SWRST bit is ongoing.

### 23.8.9 Frequency Correction

**Name:** FREQCORR  
**Offset:** 0x14  
**Reset:** 0x00  
**Property:** PAC Write-Protection, Write-Synchronized

**Note:** This register is write-synchronized: SYNCBUSY.FREQCORR must be checked to ensure the FREQCORR register synchronization is complete.

Bit	7	6	5	4	3	2	1	0
	SIGN	VALUE[6:0]						
Access	R/W	R/W	R/W	R/W	R/W	R/W	R/W	R/W
Reset	0	0	0	0	0	0	0	0

#### Bit 7 – SIGN Correction Sign

Value	Description
0	The correction value is positive, i.e., frequency will be decreased.
1	The correction value is negative, i.e., frequency will be increased.

#### Bits 6:0 – VALUE[6:0] Correction Value

These bits define the amount of correction applied to the RTC prescaler.

Value	Description
0	Correction is disabled and the RTC frequency is unchanged.
1 – 127	The RTC frequency is adjusted according to the value.



### 23.8.10 Counter Value in COUNT16 mode (CTRLA.MODE = 1)

**Name:** COUNT  
**Offset:** 0x18  
**Reset:** 0x0000  
**Property:** PAC Write-Protection, Write-Synchronized

**Notes:**

1. Prior to any read access, this register must be synchronized by the user by writing CTRLA.COUNTSYNC = 1.
2. This register is write-synchronized: SYNCBUSY.COUNT must be checked to ensure the COUNT register synchronization is complete.
3. This register must be written with a 16-bit write access.

Bit	15	14	13	12	11	10	9	8
	COUNT[15:8]							
Access	R/W	R/W	R/W	R/W	R/W	R/W	R/W	R/W
Reset	0	0	0	0	0	0	0	0
Bit	7	6	5	4	3	2	1	0
	COUNT[7:0]							
Access	R/W	R/W	R/W	R/W	R/W	R/W	R/W	R/W
Reset	0	0	0	0	0	0	0	0

**Bits 15:0 – COUNT[15:0]** Counter Value

These bits define the value of the 16-bit RTC counter in COUNT16 mode (CTRLA.MODE = 1).

### 23.8.11 Counter Period in COUNT16 mode (CTRLA.MODE=1)

**Name:** PER  
**Offset:** 0x1C  
**Reset:** 0x0000  
**Property:** PAC Write-Protection, Write-Synchronized

**Note:** This register is write-synchronized: SYNCBUSY.PER must be checked to ensure the PER register synchronization is complete.

Bit	15	14	13	12	11	10	9	8
	PER[15:8]							
Access	R/W	R/W	R/W	R/W	R/W	R/W	R/W	R/W
Reset	0	0	0	0	0	0	0	0
Bit	7	6	5	4	3	2	1	0
	PER[7:0]							
Access	R/W	R/W	R/W	R/W	R/W	R/W	R/W	R/W
Reset	0	0	0	0	0	0	0	0

#### Bits 15:0 – PER[15:0] Counter Period

These bits define the value of the 16-bit RTC period in COUNT16 mode (CTRLA.MODE=1).

### 23.8.12 Compare n Value in COUNT16 mode (CTRLA.MODE=1)

**Name:** COMP  
**Offset:** 0x20 + n\*0x02 [n=0..3]  
**Reset:** 0x0000  
**Property:** PAC Write-Protection, Write-Synchronized

**Note:** This register is write-synchronized: SYNCBUSY.COMP must be checked to ensure the COMP register synchronization is complete.

Bit	15	14	13	12	11	10	9	8
	COMP[15:8]							
Access	R/W	R/W	R/W	R/W	R/W	R/W	R/W	R/W
Reset	0	0	0	0	0	0	0	0
Bit	7	6	5	4	3	2	1	0
	COMP[7:0]							
Access	R/W	R/W	R/W	R/W	R/W	R/W	R/W	R/W
Reset	0	0	0	0	0	0	0	0

#### Bits 15:0 – COMP[15:0] Compare Value

The 16-bit value of COMPn is continuously compared with the 16-bit COUNT value. When a match occurs, the Compare n interrupt flag in the Interrupt Flag Status and Clear register (INTFLAG.CMPn) is set on the next counter cycle.

### 23.8.13 General Purpose n

**Name:** GPn  
**Offset:** 0x40 + n\*0x04 [n=0..3]  
**Reset:** 0x00000000  
**Property:** -

Bit	31	30	29	28	27	26	25	24
	GP[31:24]							
Access	R/W	R/W	R/W	R/W	R/W	R/W	R/W	R/W
Reset	0	0	0	0	0	0	0	0
Bit	23	22	21	20	19	18	17	16
	GP[23:16]							
Access	R/W	R/W	R/W	R/W	R/W	R/W	R/W	R/W
Reset	0	0	0	0	0	0	0	0
Bit	15	14	13	12	11	10	9	8
	GP[15:8]							
Access	R/W	R/W	R/W	R/W	R/W	R/W	R/W	R/W
Reset	0	0	0	0	0	0	0	0
Bit	7	6	5	4	3	2	1	0
	GP[7:0]							
Access	R/W	R/W	R/W	R/W	R/W	R/W	R/W	R/W
Reset	0	0	0	0	0	0	0	0

#### Bits 31:0 – GP[31:0] General Purpose

These bits are for user-defined general purpose use, see [23.6.8.4. General Purpose Registers](#).

## 23.8.14 Tamper Control

**Name:** TAMPCTRL  
**Offset:** 0x60  
**Reset:** 0x00000000  
**Property:** PAC Write-Protection, Enable-Protected

Bit	31	30	29	28	27	26	25	24
				DEBNC4	DEBNC3	DEBNC2	DEBNC1	DEBNC0
Access								
Reset				0	0	0	0	0
Bit	23	22	21	20	19	18	17	16
				TAMLVL4	TAMLVL3	TAMLVL2	TAMLVL1	TAMLVL0
Access								
Reset				0	0	0	0	0
Bit	15	14	13	12	11	10	9	8
							IN4ACT[1:0]	
Access								
Reset							0	0
Bit	7	6	5	4	3	2	1	0
	IN3ACT[1:0]		IN2ACT[1:0]		IN1ACT[1:0]		IN0ACT[1:0]	
Access								
Reset	0	0	0	0	0	0	0	0

**Bits 24, 25, 26, 27, 28 – DEBNCn** Debounce Enable of Tamper Input INn [n=0..3]

**Note:** Debounce feature does not apply to the Active Layer Protection mode (TAMPCTRL.INACT = ACTL).

Value	Description
0	Debouncing is disabled for Tamper input INn
1	Debouncing is enabled for Tamper input INn

**Bits 16, 17, 18, 19, 20 – TAMLVLn** Tamper Level Select of Tamper Input INn [n=0..3]

**Note:** Tamper Level feature does not apply to the Active Layer Protection mode (TAMPCTRL.INACT = ACTL).

Value	Description
0	A falling edge condition will be detected on Tamper input INn.
1	A rising edge condition will be detected on Tamper input INn.

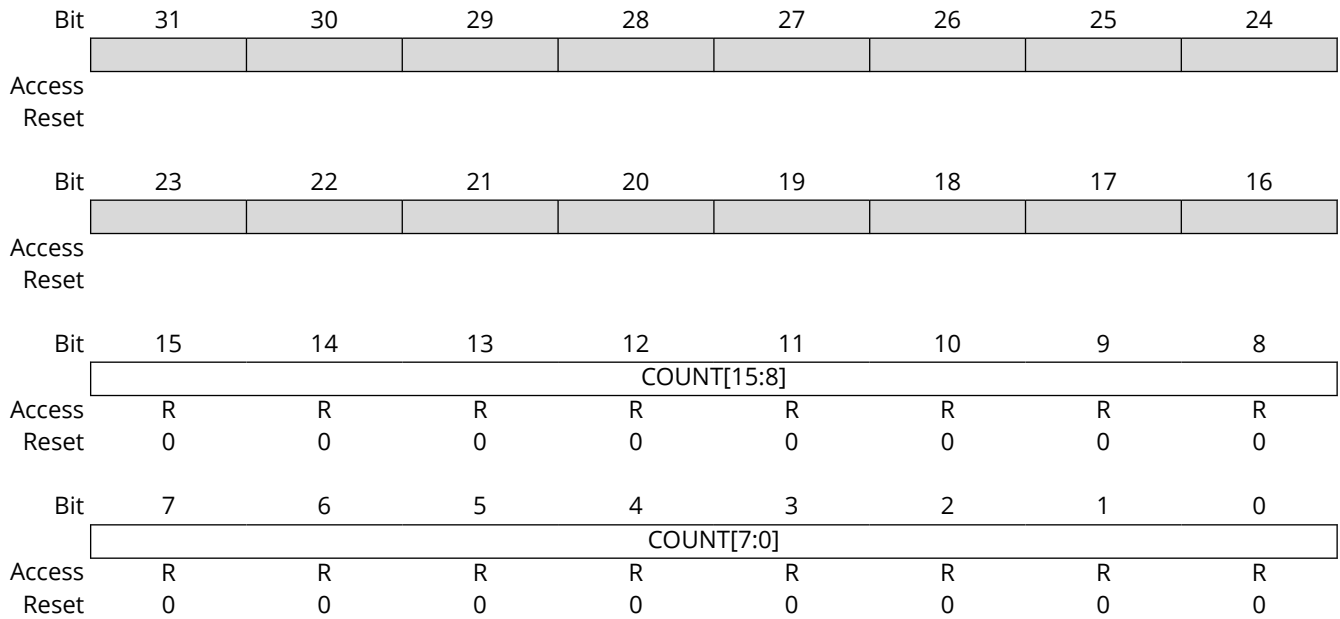
**Bits 0:1, 2:3, 4:5, 6:7, 8:9 – INnACT** Tamper Channel n Action [n=0..3]

These bits determine the action taken by Tamper Channel n.

Value	Name	Description
0x0	OFF	Off (Disabled)
0x1	WAKE	Wake and set Tamper flag
0x2	CAPTURE	Capture timestamp and set Tamper flag
0x3	ACTL	Compare RTC signal routed between INn and OUT pins . When a mismatch occurs, capture timestamp and set Tamper flag

### 23.8.15 Timestamp

**Name:**       TIMESTAMP  
**Offset:**     0x64  
**Reset:**       0x0000  
**Property:**   -



**Bits 15:0 – COUNT[15:0]** Count Timestamp Value

The 16-bit value of COUNT is captured by the TIMESTAMP when a tamper condition occurs.

### 23.8.16 Tamper ID

**Name:** TAMPID  
**Offset:** 0x68  
**Reset:** 0x00000000

Bit	31	30	29	28	27	26	25	24
	TAMPEVT							
Access	R/W							
Reset	0							
Bit	23	22	21	20	19	18	17	16
Access								
Reset								
Bit	15	14	13	12	11	10	9	8
Access								
Reset								
Bit	7	6	5	4	3	2	1	0
				TAMPID4	TAMPID3	TAMPID2	TAMPID1	TAMPID0
Access				R/W	R/W	R/W	R/W	R/W
Reset				0	0	0	0	0

#### Bit 31 – TAMPEVT Tamper Event Detected

Writing a '0' to this bit has no effect. Writing a '1' to this bit clears the tamper detection bit.

Value	Description
0	A tamper input event has not been detected
1	A tamper input event has been detected

#### Bits 0, 1, 2, 3, 4 – TAMPIDn Tamper on Channel n Detected [n=0..3]

Writing a '0' to this bit has no effect. Writing a '1' to this bit clears the tamper detection bit.

Value	Description
0	A tamper condition has not been detected on Channel n
1	A tamper condition has been detected on Channel n

### 23.8.17 Backup n

**Name:** BKUP  
**Offset:** 0x80 + n\*0x04 [n=0..7]  
**Reset:** 0x00000000  
**Property:** PAC Write-Protection

Bit	31	30	29	28	27	26	25	24
	BKUP[31:24]							
Access	R/W	R/W	R/W	R/W	R/W	R/W	R/W	R/W
Reset	0	0	0	0	0	0	0	0
Bit	23	22	21	20	19	18	17	16
	BKUP[23:16]							
Access	R/W	R/W	R/W	R/W	R/W	R/W	R/W	R/W
Reset	0	0	0	0	0	0	0	0
Bit	15	14	13	12	11	10	9	8
	BKUP[15:8]							
Access	R/W	R/W	R/W	R/W	R/W	R/W	R/W	R/W
Reset	0	0	0	0	0	0	0	0
Bit	7	6	5	4	3	2	1	0
	BKUP[7:0]							
Access	R/W	R/W	R/W	R/W	R/W	R/W	R/W	R/W
Reset	0	0	0	0	0	0	0	0

#### Bits 31:0 – BKUP[31:0] Backup

These bits are user-defined for general purpose use in the Backup domain.



## 23.9 Register Summary - Mode 2 - Clock/Calendar

Offset	Name	Bit Pos.	7	6	5	4	3	2	1	0
0x00	CTRLA	7:0	MATCHCLR	CLKREP			MODE[1:0]		ENABLE	SWRST
		15:8	CLOCKSYNC		BKTRST		PRESCALER[3:0]			
0x02	CTRLB	7:0	DMAEN	RTCOUT	DEBASYNC				GP2EN	GP0EN
		15:8			ACTF[2:0]				DEBF[2:0]	
0x04	EVCTRL	7:0	PEREO7	PEREO6	PEREO5	PEREO4	PEREO3	PEREO2	PEREO1	PEREO0
		15:8	OVFEO	TAMPERO					ALARMEO1	ALARMEO0
		23:16								TAMPEVEI
0x08	INTENCLR	7:0	PER7	PER6	PER5	PER4	PER3	PER2	PER1	PER0
		15:8	OVF	TAMPER					ALARM1	ALARM0
0x0A	INTENSET	7:0	PER7	PER6	PER5	PER4	PER3	PER2	PER1	PER0
		15:8	OVF	TAMPER					ALARM1	ALARM0
0x0C	INTFLAG	7:0	PER7	PER6	PER5	PER4	PER3	PER2	PER1	PER0
		15:8	OVF	TAMPER					ALARM1	ALARM0
0x0E	DBGCTRL	7:0								DBGRUN
0x0F	Reserved									
0x10	SYNCBUSY	7:0		ALARM1	ALARM0		CLOCK	FREQCORR	ENABLE	SWRST
		15:8	CLOCKSYNC			MASK1	MASK0			
		23:16					GP3	GP2	GP1	GP0
		31:24								
0x14	FREQCORR	7:0	SIGN	VALUE[6:0]						
0x15 ... 0x17	Reserved									
0x18	CLOCK	7:0	MINUTE[1:0]			SECOND[5:0]				
		15:8	HOUR[3:0]			MINUTE[5:2]				
		23:16	MONTH[1:0]		DAY[4:0]		HOUR[4]			
		31:24	YEAR[5:0]				MONTH[3:2]			
0x1C ... 0x1F	Reserved									
0x20	ALARM0	7:0	MINUTE[1:0]			SECOND[5:0]				
		15:8	HOUR[3:0]			MINUTE[5:2]				
		23:16	MONTH[1:0]		DAY[4:0]		HOUR[4]			
		31:24	YEAR[5:0]				MONTH[3:2]			
0x24	MASK0	7:0					SEL[2:0]			
0x25 ... 0x27	Reserved									
0x28	ALARM1	7:0	MINUTE[1:0]			SECOND[5:0]				
		15:8	HOUR[3:0]			MINUTE[5:2]				
		23:16	MONTH[1:0]		DAY[4:0]		HOUR[4]			
		31:24	YEAR[5:0]				MONTH[3:2]			
0x2C	MASK1	7:0					SEL[2:0]			
0x2D ... 0x3F	Reserved									
0x40	GP0	7:0	GP[7:0]							
		15:8	GP[15:8]							
		23:16	GP[23:16]							
		31:24	GP[31:24]							
0x44	GP1	7:0	GP[7:0]							
		15:8	GP[15:8]							
		23:16	GP[23:16]							
		31:24	GP[31:24]							
0x48	GP2	7:0	GP[7:0]							
		15:8	GP[15:8]							
		23:16	GP[23:16]							
		31:24	GP[31:24]							

.....continued													
Offset	Name	Bit Pos.	7	6	5	4	3	2	1	0			
0x4C	GP3	7:0	GP[7:0]										
		15:8	GP[15:8]										
		23:16	GP[23:16]										
		31:24	GP[31:24]										
0x50 ... 0x5F	Reserved												
0x60	TAMPCTRL	7:0	IN3ACT[1:0]		IN2ACT[1:0]		IN1ACT[1:0]		IN0ACT[1:0]				
		15:8	IN4ACT[1:0]										
		23:16			TAMLVL4		TAMLVL3		TAMLVL2		TAMLVL1		TAMLVL0
		31:24			DEBNC4		DEBNC3		DEBNC2		DEBNC1		DEBNC0
0x64	TIMESTAMP	7:0	MINUTE[1:0]			SECOND[5:0]							
		15:8	HOUR[3:0]				MINUTE[5:2]						
		23:16	MONTH[1:0]			DAY[4:0]				HOUR[4]			
		31:24	YEAR[5:0]						MONTH[3:2]				
0x68	TAMPID	7:0			TAMPID4		TAMPID3		TAMPID2		TAMPID1		TAMPID0
		15:8											
		23:16											
		31:24	TAMPEVT										
0x6C ... 0x7F	Reserved												
0x80	BKUP0	7:0	BKUP[7:0]										
		15:8	BKUP[15:8]										
		23:16	BKUP[23:16]										
		31:24	BKUP[31:24]										
0x84	BKUP1	7:0	BKUP[7:0]										
		15:8	BKUP[15:8]										
		23:16	BKUP[23:16]										
		31:24	BKUP[31:24]										
0x88	BKUP2	7:0	BKUP[7:0]										
		15:8	BKUP[15:8]										
		23:16	BKUP[23:16]										
		31:24	BKUP[31:24]										
0x8C	BKUP3	7:0	BKUP[7:0]										
		15:8	BKUP[15:8]										
		23:16	BKUP[23:16]										
		31:24	BKUP[31:24]										
0x90	BKUP4	7:0	BKUP[7:0]										
		15:8	BKUP[15:8]										
		23:16	BKUP[23:16]										
		31:24	BKUP[31:24]										
0x94	BKUP5	7:0	BKUP[7:0]										
		15:8	BKUP[15:8]										
		23:16	BKUP[23:16]										
		31:24	BKUP[31:24]										
0x98	BKUP6	7:0	BKUP[7:0]										
		15:8	BKUP[15:8]										
		23:16	BKUP[23:16]										
		31:24	BKUP[31:24]										
0x9C	BKUP7	7:0	BKUP[7:0]										
		15:8	BKUP[15:8]										
		23:16	BKUP[23:16]										
		31:24	BKUP[31:24]										

### 23.9.1 Control A in Clock/Calendar mode (CTRLA.MODE = 2)

**Name:** CTRLA  
**Offset:** 0x00  
**Reset:** 0x0000  
**Property:** PAC Write-Protection, Enable-Protected Bits, Write-Synchronized Bits

Bit	15	14	13	12	11	10	9	8
	CLOCKSYNC		BKTRST		PRESCALER[3:0]			
Access	R/W		R/W		R/W	R/W	R/W	R/W
Reset	0		0		0	0	0	0
Bit	7	6	5	4	3	2	1	0
	MATCHCLR	CLKREP			MODE[1:0]		ENABLE	SWRST
Access	R/W	R/W			R/W	R/W	R/W	R/W
Reset	0	0			0	0	0	0

#### Bit 15 - CLOCKSYNC CLOCK Read Synchronization Enable

The CLOCK register requires synchronization when reading. Disabling the synchronization will prevent reading valid values from the CLOCK register.

This bit is not enable-protected.

**Note:** For the first value read, read the CLOCK register prior to enable the CLOCK read synchronization (CLOCKSYNC = 0). After enabling the CLOCK read synchronization (CLOCKSYNC = 1), read the CLOCK register until its value is changed when compared to its first value read. All subsequent CLOCK values are then valid.

Value	Description
0	CLOCK read synchronization is disabled
1	CLOCK read synchronization is enabled

#### Bit 13 - BKTRST BKUP Registers Reset On Tamper Enable

All BKUPn registers are affected. This bit can be written only when the peripheral is disabled.

This bit is not synchronized.

Value	Description
0	BKUPn registers will not reset when a tamper condition occurs.
1	BKUPn registers will reset when a tamper condition occurs.

#### Bits 11:8 - PRESCALER[3:0] Prescaler

These bits define the prescaling factor for the RTC clock source (GCLK\_RTC) to generate the counter clock (CLK\_RTC\_CNT). Periodic events and interrupts are not available when the prescaler is off.

These bits are not synchronized.

Value	Name	Description
0x0	OFF	CLK_RTC_CNT = GCLK_RTC/1
0x1	DIV1	CLK_RTC_CNT = GCLK_RTC/1
0x2	DIV2	CLK_RTC_CNT = GCLK_RTC/2
0x3	DIV4	CLK_RTC_CNT = GCLK_RTC/4
0x4	DIV8	CLK_RTC_CNT = GCLK_RTC/8
0x5	DIV16	CLK_RTC_CNT = GCLK_RTC/16
0x6	DIV32	CLK_RTC_CNT = GCLK_RTC/32
0x7	DIV64	CLK_RTC_CNT = GCLK_RTC/64
0x8	DIV128	CLK_RTC_CNT = GCLK_RTC/128
0x9	DIV256	CLK_RTC_CNT = GCLK_RTC/256
0xA	DIV512	CLK_RTC_CNT = GCLK_RTC/512
0xB	DIV1024	CLK_RTC_CNT = GCLK_RTC/1024
0xC-0xF	-	Reserved

### Bit 7 – MATCHCLR Clear on Match

This bit is valid only in Mode 0 (COUNT32) and Mode 2 (CLOCK). This bit can be written only when the peripheral is disabled. This bit is not synchronized.

Value	Description
0	The counter is not cleared on a Compare/Alarm 0 match
1	The counter is cleared on a Compare/Alarm 0 match

### Bit 6 – CLKREP Clock Representation

This bit is valid only in Mode 2 and determines how the hours are represented in the Clock Value (CLOCK) register. This bit can be written only when the peripheral is disabled. This bit is not synchronized.

Value	Description
0	24 Hour
1	12 Hour (AM/PM)

### Bits 3:2 – MODE[1:0] Operating Mode

This field defines the operating mode of the RTC. This bit is not synchronized.

Value	Name	Description
0x0	COUNT32	Mode 0: 32-bit counter
0x1	COUNT16	Mode 1: 16-bit counter
0x2	CLOCK	Mode 2: Clock/calendar
0x3	-	Reserved

### Bit 1 – ENABLE Enable

Due to synchronization there is delay from writing CTRLA.ENABLE until the peripheral is enabled/disabled. The value written to CTRLA.ENABLE will read back immediately and the Enable bit in the Synchronization Busy register (SYNCBUSY.ENABLE) will be set. SYNCBUSY.ENABLE will be cleared when the operation is complete.

Value	Description
0	The peripheral is disabled
1	The peripheral is enabled

### Bit 0 – SWRST Software Reset

Writing a '0' to this bit has no effect.

Writing a '1' to this bit resets all registers in the RTC, except DBGCTRL, to their initial state, and the RTC will be disabled.

Writing a '1' to CTRLA.SWRST will always take precedence, meaning that all other writes in the same write-operation will be discarded.

Due to synchronization there is a delay from writing CTRLA.SWRST until the reset is complete. CTRLA.SWRST will be cleared when the reset is complete.

#### Notes:

1. When the CTRLA.SWRST is written, the user must poll the SYNCBUSY.SWRST bit to know when the reset operation is complete.
2. During a SWRST, access to registers/bits without the SWRST are disallowed until the SYNCBUSY.SWRST is cleared by hardware.

Value	Description
0	There is not reset operation ongoing
1	The reset operation is ongoing

## 23.9.2 Control B in Clock/Calendar mode (CTRLA.MODE=2)

**Name:** CTRLB  
**Offset:** 0x2  
**Reset:** 0x0000  
**Property:** PAC Write-Protection, Enable-Protected

Bit	15	14	13	12	11	10	9	8
			ACTF[2:0]			DEBF[2:0]		
Access		R/W	R/W	R/W		R/W	R/W	R/W
Reset		0	0	0		0	0	0
Bit	7	6	5	4	3	2	1	0
	DMAEN	RTCOUT	DEBASYNC			GP2EN		GPOEN
Access	R/W	R/W	R/W				R/W	R/W
Reset	0	0	0				0	0

### Bits 14:12 – ACTF[2:0] Active Layer Frequency

These bits define the prescaling factor for the RTC clock output (OUT) used during active layer protection in terms of the CLK\_RTC.

Value	Name	Description
0x0	DIV2	CLK_RTC_OUT = CLK_RTC / 2
0x1	DIV4	CLK_RTC_OUT = CLK_RTC / 4
0x2	DIV8	CLK_RTC_OUT = CLK_RTC / 8
0x3	DIV16	CLK_RTC_OUT = CLK_RTC / 16
0x4	DIV32	CLK_RTC_OUT = CLK_RTC / 32
0x5	DIV64	CLK_RTC_OUT = CLK_RTC / 64
0x6	DIV128	CLK_RTC_OUT = CLK_RTC / 128
0x7	DIV256	CLK_RTC_OUT = CLK_RTC / 256

### Bits 10:8 – DEBF[2:0] Debounce Frequency

These bits define the prescaling factor for the input debouncers in terms of the CLK\_RTC.

Value	Name	Description
0x0	DIV2	CLK_RTC_DEB = CLK_RTC / 2
0x1	DIV4	CLK_RTC_DEB = CLK_RTC / 4
0x2	DIV8	CLK_RTC_DEB = CLK_RTC / 8
0x3	DIV16	CLK_RTC_DEB = CLK_RTC / 16
0x4	DIV32	CLK_RTC_DEB = CLK_RTC / 32
0x5	DIV64	CLK_RTC_DEB = CLK_RTC / 64
0x6	DIV128	CLK_RTC_DEB = CLK_RTC / 128
0x7	DIV256	CLK_RTC_DEB = CLK_RTC / 256

### Bit 7 – DMAEN DMA Enable

The RTC can trigger a DMA request when the timestamp is ready in the TIMESTAMP register.

Value	Description
0	Tamper DMA request is disabled. Reading TIMESTAMP has no effect on INTFLAG.TAMPER.
1	Tamper DMA request is enabled. Reading TIMESTAMP will clear INTFLAG.TAMPER.

### Bit 6 – RTCOUT RTC Out Enable

Value	Description
0	The RTC active layer output is disabled.
1	The RTC active layer output is enabled.

### Bit 5 – DEBASYNC Debouncer Asynchronous Enable

Value	Description
0	The tamper input debouncers operate synchronously.
1	The tamper input debouncers operate asynchronously.

**Bit 1 – GP2EN** General Purpose 2 Enable

Value	Description
0	COMP1 compare function enabled. GP2/GP3 disabled.
1	COMP1 compare function disabled. GP2/GP3 enabled.

**Bit 0 – GPOEN** General Purpose 0 Enable

Value	Description
0	COMP0 compare function enabled. GP0 disabled.
1	COMP0 compare function disabled. GP0 enabled.

### 23.9.3 Event Control in Clock/Calendar mode (CTRLA.MODE=2)

**Name:** EVCTRL  
**Offset:** 0x04  
**Reset:** 0x00000000  
**Property:** PAC Write-Protection, Enable-Protected

Bit	31	30	29	28	27	26	25	24
Access								
Reset								
Bit	23	22	21	20	19	18	17	16
Access								TAMPEVEI
Reset								R/W 0
Bit	15	14	13	12	11	10	9	8
Access	OVFEO	TAMPEREO					ALARMEO1	ALARMEO0
Reset	R/W 0	R/W 0					R/W 0	R/W 0
Bit	7	6	5	4	3	2	1	0
Access	PEREO7	PEREO6	PEREO5	PEREO4	PEREO3	PEREO2	PEREO1	PEREO0
Reset	R/W 0	R/W 0	R/W 0	R/W 0	R/W 0	R/W 0	R/W 0	R/W 0

#### Bit 16 – TAMPEVEI Tamper Event Input Enable

Value	Description
0	Tamper event input is disabled, and incoming events will be ignored.
1	Tamper event input is enabled, and all incoming events will capture the CLOCK value.

#### Bit 15 – OVFEO Overflow Event Output Enable

Value	Description
0	Overflow event is disabled and will not be generated.
1	Overflow event is enabled and will be generated for every overflow.

#### Bit 14 – TAMPEREO Tamper Event Output Enable

Value	Description
0	Tamper event output is disabled, and will not be generated
1	Tamper event output is enabled, and will be generated for every tamper input.

#### Bits 8, 9 – ALARMEOn Alarm n Event Output Enable [n = 1..0]

Value	Description
0	Alarm n event is disabled and will not be generated.
1	Alarm n event is enabled and will be generated for every compare match.

#### Bits 0, 1, 2, 3, 4, 5, 6, 7 – PEREO n Periodic Interval n Event Output Enable [n = 7..0]

Value	Description
0	Periodic Interval n event is disabled and will not be generated.
1	Periodic Interval n event is enabled and will be generated.

### 23.9.4 Interrupt Enable Clear in Clock/Calendar mode (CTRLA.MODE=2)

**Name:** INTENCLR  
**Offset:** 0x08  
**Reset:** 0x0000  
**Property:** PAC Write-Protection

This register allows the user to disable an interrupt without doing a read-modify-write operation. Changes in this register will also be reflected in the Interrupt Enable Set (INTENSET) register.

Bit	15	14	13	12	11	10	9	8
	OVF	TAMPER					ALARM1	ALARM0
Access	R/W	R/W					R/W	R/W
Reset	0	0					0	0
Bit	7	6	5	4	3	2	1	0
	PER7	PER6	PER5	PER4	PER3	PER2	PER1	PER0
Access	R/W	R/W	R/W	R/W	R/W	R/W	R/W	R/W
Reset	0	0	0	0	0	0	0	0

#### Bit 15 – OVF Overflow Interrupt Enable

Writing a '0' to this bit has no effect. Writing a '1' to this bit will clear the Overflow Interrupt Enable bit, which disables the Overflow interrupt.

Value	Description
0	The Overflow interrupt is disabled.
1	The Overflow interrupt is enabled.

#### Bit 14 – TAMPER Tamper Interrupt Enable

#### Bits 8, 9 – ALARMn Alarm n Interrupt Enable [n = 1..0]

Writing a '0' to this bit has no effect. Writing a '1' to this bit will clear the Alarm n Interrupt Enable bit, which disables the Alarm n interrupt.

Value	Description
0	The Alarm n interrupt is disabled.
1	The Alarm n interrupt is enabled.

#### Bits 0, 1, 2, 3, 4, 5, 6, 7 – PERn Periodic Interval n Interrupt Enable [n = 7..0]

Writing a '0' to this bit has no effect. Writing a '1' to this bit will clear the Periodic Interval n Interrupt Enable bit, which disables the Periodic Interval n interrupt.

Value	Description
0	Periodic Interval n interrupt is disabled.
1	Periodic Interval n interrupt is enabled.



### 23.9.5 Interrupt Enable Set in Clock/Calendar mode (CTRLA.MODE=2)

**Name:** INTENSET  
**Offset:** 0x0A  
**Reset:** 0x0000  
**Property:** PAC Write-Protection

This register allows the user to enable an interrupt without doing a read-modify-write operation. Changes in this register will also be reflected in the Interrupt Enable Clear (INTENCLR) register.

Bit	15	14	13	12	11	10	9	8
	OVF	TAMPER					ALARM1	ALARM0
Access	R/W	R/W					R/W	R/W
Reset	0	0					0	0
Bit	7	6	5	4	3	2	1	0
	PER7	PER6	PER5	PER4	PER3	PER2	PER1	PER0
Access	R/W	R/W	R/W	R/W	R/W	R/W	R/W	R/W
Reset	0	0	0	0	0	0	0	0

#### Bit 15 – OVF Overflow Interrupt Enable

Writing a '0' to this bit has no effect. Writing a '1' to this bit will set the Overflow Interrupt Enable bit, which enables the Overflow interrupt.

Value	Description
0	The Overflow interrupt is disabled.
1	The Overflow interrupt is enabled.

#### Bit 14 – TAMPER Tamper Interrupt Enable

Writing a '0' to this bit has no effect. Writing a '1' to this bit will set the Tamper Interrupt Enable bit, which enables the Tamper interrupt.

Value	Description
0	The Tamper interrupt is disabled.
1	The Tamper interrupt is enabled.

#### Bits 8, 9 – ALARMn Alarm n Interrupt Enable [n = 1..0]

Writing a '0' to this bit has no effect. Writing a '1' to this bit will set the Alarm n Interrupt Enable bit, which enables the Alarm n interrupt.

Value	Description
0	The Alarm n interrupt is disabled.
1	The Alarm n interrupt is enabled.

#### Bits 0, 1, 2, 3, 4, 5, 6, 7 – PERn Periodic Interval n Interrupt Enable [n = 7..0]

Writing a '0' to this bit has no effect. Writing a '1' to this bit will set the Periodic Interval n Interrupt Enable bit, which enables the Periodic Interval n interrupt.

Value	Description
0	Periodic Interval n interrupt is disabled.
1	Periodic Interval n interrupt is enabled.

## 23.9.6 Interrupt Flag Status and Clear in Clock/Calendar mode (CTRLA.MODE=2)

**Name:** INTFLAG  
**Offset:** 0x0C  
**Reset:** 0x0000  
**Property:** -

Bit	15	14	13	12	11	10	9	8
	OVF	TAMPER					ALARM1	ALARM0
Access	R/W	R/W					R/W	R/W
Reset	0	0					0	0

Bit	7	6	5	4	3	2	1	0
	PER7	PER6	PER5	PER4	PER3	PER2	PER1	PER0
Access	R/W	R/W	R/W	R/W	R/W	R/W	R/W	R/W
Reset	0	0	0	0	0	0	0	0

### Bit 15 - OVF Overflow

This flag is cleared by writing a '1' to the flag.

This flag is set on the next CLK\_RTC\_CNT cycle after an overflow condition occurs, and an interrupt request will be generated if INTENCLR/SET.OVF is '1'.

Writing a '0' to this bit has no effect.

Writing a '1' to this bit clears the Overflow interrupt flag.

### Bit 14 - TAMPER Tamper

This flag is set after a tamper condition occurs, and an interrupt request will be generated if INTENCLR.TAMPER/INTENSET.TAMPER is '1'. Writing a '0' to this bit has no effect. Writing a '1' to this bit clears the Tamper interrupt flag.

### Bits 8, 9 - ALARMn Alarm n [n = 1..0]

This flag is cleared by writing a '1' to the flag.

This flag is set on the next CLK\_RTC\_CNT cycle after a match with the compare condition, and an interrupt request will be generated if INTENCLR/SET.ALARMn is one.

Writing a '0' to this bit has no effect.

Writing a '1' to this bit clears the Alarm n interrupt flag.

### Bits 0, 1, 2, 3, 4, 5, 6, 7 - PERn Periodic Interval n [n = 7..0]

This flag is cleared by writing a '1' to the flag.

This flag is set on the 0-to-1 transition of prescaler bit [n+2], and an interrupt request will be generated if INTENCLR/SET.PERx is '1'.

Writing a '0' to this bit has no effect.

Writing a '1' to this bit clears the Periodic Interval n interrupt flag.

### 23.9.7 Debug Control

**Name:** DBGCTRL  
**Offset:** 0x0E  
**Reset:** 0x00  
**Property:** PAC Write-Protection

Bit	7	6	5	4	3	2	1	0
								DBGRUN
Access								R/W
Reset								0

#### Bit 0 – DBGRUN Debug Run

This bit is not reset by a software reset.

This bit controls the functionality when the CPU is halted by an external debugger.

Value	Description
0	The RTC is halted when the CPU is halted by an external debugger.
1	The RTC continues normal operation when the CPU is halted by an external debugger.

### 23.9.8 Synchronization Busy in Clock/Calendar mode (CTRLA.MODE=2)

**Name:** SYNCBUSY  
**Offset:** 0x10  
**Reset:** 0x00000000  
**Property:** -

Bit	31	30	29	28	27	26	25	24
Access								
Reset								
Bit	23	22	21	20	19	18	17	16
Access					GP3	GP2	GP1	GP0
Reset					R	R	R	R
Bit	15	14	13	12	11	10	9	8
Access	CLOCKSYNC			MASK1	MASK0			
Reset	R			R	R			
Bit	7	6	5	4	3	2	1	0
Access		ALARM1	ALARM0		CLOCK	FREQCORR	ENABLE	SWRST
Reset		R	R		R	R	R	R
Bit	7	6	5	4	3	2	1	0
Reset		0	0		0	0	0	0

#### Bits 16, 17, 18, 19 – GPn General Purpose n Synchronization Busy Status

Value	Description
0	Write synchronization for GPn register is complete.
1	Write synchronization for GPn register is ongoing.

#### Bit 15 – CLOCKSINC Clock Read Sync Enable Synchronization Busy Status

Value	Description
0	Write synchronization for CTRLA.CLOCKSINC bit is complete.
1	Write synchronization for CTRLA.CLOCKSINC bit is ongoing.

#### Bits 11, 12 – MASKn Mask n Synchronization Busy Status [n = 1..0]

Value	Description
0	Write synchronization for MASKx register is complete.
1	Write synchronization for MASKx register is ongoing.

#### Bits 5, 6 – ALARMn Alarm n Synchronization Busy Status [n = 1..0]

Value	Description
0	Write synchronization for ALARMx register is complete.
1	Write synchronization for ALARMx register is ongoing.

#### Bit 3 – CLOCK Clock Register Synchronization Busy Status

Value	Description
0	Read/write synchronization for CLOCK register is complete.
1	Read/write synchronization for CLOCK register is ongoing.

#### Bit 2 – FREQCORR Frequency Correction Synchronization Busy Status

Value	Description
0	Write synchronization for FREQCORR register is complete.
1	Write synchronization for FREQCORR register is ongoing.

**Bit 1 – ENABLE** Enable Synchronization Busy Status

Value	Description
0	Write synchronization for CTRLA.ENABLE bit is complete.
1	Write synchronization for CTRLA.ENABLE bit is ongoing.

**Bit 0 – SWRST** Software Reset Synchronization Busy Status

Value	Description
0	Write synchronization for CTRLA.SWRST bit is complete.
1	Write synchronization for CTRLA.SWRST bit is ongoing.

### 23.9.9 Frequency Correction

**Name:** FREQCORR  
**Offset:** 0x14  
**Reset:** 0x00  
**Property:** PAC Write-Protection, Write-Synchronized

**Note:** This register is write-synchronized: SYNCBUSY.FREQCORR must be checked to ensure the FREQCORR register synchronization is complete.

Bit	7	6	5	4	3	2	1	0
	SIGN	VALUE[6:0]						
Access	R/W	R/W	R/W	R/W	R/W	R/W	R/W	R/W
Reset	0	0	0	0	0	0	0	0

#### Bit 7 – SIGN Correction Sign

Value	Description
0	The correction value is positive, i.e., frequency will be decreased.
1	The correction value is negative, i.e., frequency will be increased.

#### Bits 6:0 – VALUE[6:0] Correction Value

These bits define the amount of correction applied to the RTC prescaler.

Value	Description
0	Correction is disabled and the RTC frequency is unchanged.
1 – 127	The RTC frequency is adjusted according to the value.

### 23.9.10 Clock Value in Clock/Calendar mode (CTRLA.MODE=2)

**Name:** CLOCK  
**Offset:** 0x18  
**Reset:** 0x00000000  
**Property:** PAC Write-Protection, Write-Synchronized, Read-Synchronized

**Notes:**

1. This register is read-synchronized and write-synchronized: SYNCBUSY.CLOCK must be checked to ensure the CLOCK register synchronization is complete.
2. This register must be written with a 32-bit write access.

Bit	31	30	29	28	27	26	25	24
	YEAR[5:0]						MONTH[3:2]	
Access	R/W	R/W	R/W	R/W	R/W	R/W	R/W	R/W
Reset	0	0	0	0	0	0	0	0
Bit	23	22	21	20	19	18	17	16
	MONTH[1:0]		DAY[4:0]				HOUR[4]	
Access	R/W	R/W	R/W	R/W	R/W	R/W	R/W	R/W
Reset	0	0	0	0	0	0	0	0
Bit	15	14	13	12	11	10	9	8
	HOUR[3:0]				MINUTE[5:2]			
Access	R/W	R/W	R/W	R/W	R/W	R/W	R/W	R/W
Reset	0	0	0	0	0	0	0	0
Bit	7	6	5	4	3	2	1	0
	MINUTE[1:0]		SECOND[5:0]					
Access	R/W	R/W	R/W	R/W	R/W	R/W	R/W	R/W
Reset	0	0	0	0	0	0	0	0

**Bits 31:26 – YEAR[5:0]** Year

The year offset with respect to the reference year (defined in software).  
The year is considered a leap year if YEAR[1:0] is zero.

**Bits 25:22 – MONTH[3:0]** Month

- 1 – January
- 2 – February
- ...
- 12 – December

**Bits 21:17 – DAY[4:0]** Day

Day starts at 1 and ends at 28, 29, 30, or 31, depending on the month and year.

**Bits 16:12 – HOUR[4:0]** Hour

When CTRLA.CLKREP=0, the Hour bit group is in 24-hour format, with values 0-23. When CTRLA.CLKREP=1, HOUR[3:0] has values 1-12, and HOUR[4] represents AM (0) or PM (1).

**Bits 11:6 – MINUTE[5:0]** Minute

0 – 59

**Bits 5:0 – SECOND[5:0]** Second

0 – 59

### 23.9.11 Alarm n Value in Clock/Calendar mode (CTRLA.MODE=2)

**Name:** ALARM  
**Offset:** 0x20 + n\*0x08 [n=0..1]  
**Reset:** 0x00000000  
**Property:** PAC Write-Protection, Write-Synchronized

**Note:** This register is write-synchronized: SYNCBUSY.ALARM must be checked to ensure the ALARM register synchronization is complete.

The 32-bit value of ALARMn is continuously compared with the 32-bit CLOCK value, based on the masking set by MASKn.SEL. When a match occurs, the Alarm n interrupt flag in the Interrupt Flag Status and Clear register (INTFLAG.ALARMn) is set on the next counter cycle, and the counter is cleared if CTRLA.MATCHCLR is '1'.

Bit	31	30	29	28	27	26	25	24
	YEAR[5:0]						MONTH[3:2]	
Access	R/W	R/W	R/W	R/W	R/W	R/W	R/W	R/W
Reset	0	0	0	0	0	0	0	0
Bit	23	22	21	20	19	18	17	16
	MONTH[1:0]		DAY[4:0]				HOUR[4]	
Access	R/W	R/W	R/W	R/W	R/W	R/W	R/W	R/W
Reset	0	0	0	0	0	0	0	0
Bit	15	14	13	12	11	10	9	8
	HOUR[3:0]			MINUTE[5:2]				
Access	R/W	R/W	R/W	R/W	R/W	R/W	R/W	R/W
Reset	0	0	0	0	0	0	0	0
Bit	7	6	5	4	3	2	1	0
	MINUTE[1:0]		SECOND[5:0]					
Access	R/W	R/W	R/W	R/W	R/W	R/W	R/W	R/W
Reset	0	0	0	0	0	0	0	0

#### Bits 31:26 – YEAR[5:0] Year

The alarm year. Years are only matched if MASKn.SEL is 6

#### Bits 25:22 – MONTH[3:0] Month

The alarm month. Months are matched only if MASKn.SEL is greater than 4.

#### Bits 21:17 – DAY[4:0] Day

The alarm day. Days are matched only if MASKn.SEL is greater than 3.

#### Bits 16:12 – HOUR[4:0] Hour

The alarm hour. Hours are matched only if MASKn.SEL is greater than 2.

#### Bits 11:6 – MINUTE[5:0] Minute

The alarm minute. Minutes are matched only if MASKn.SEL is greater than 1.

#### Bits 5:0 – SECOND[5:0] Second

The alarm second. Seconds are matched only if MASKn.SEL is greater than 0.



### 23.9.12 Alarm n Mask in Clock/Calendar mode (CTRLA.MODE=2)

**Name:** MASK  
**Offset:** 0x24 + n\*0x08 [n=0..1]  
**Reset:** 0x00  
**Property:** PAC Write-Protection, Write-Synchronized

**Note:** This register is write-synchronized: SYNCBUSY.MASK must be checked to ensure the MASK register synchronization is complete.

Bit	7	6	5	4	3	2	1	0
						SEL[2:0]		
Access						R/W	R/W	R/W
Reset						0	0	0

#### Bits 2:0 – SEL[2:0] Alarm Mask Selection

These bits define which bit groups of Alarm n are valid.

Value	Name	Description
0x0	OFF	Alarm Disabled
0x1	SS	Match seconds only
0x2	MMSS	Match seconds and minutes only
0x3	HHMMSS	Match seconds, minutes, and hours only
0x4	DDHHMMSS	Match seconds, minutes, hours, and days only
0x5	MMDDHHMMSS	Match seconds, minutes, hours, days, and months only
0x6	YYMMDDHHMMSS	Match seconds, minutes, hours, days, months, and years
0x7	-	Reserved

### 23.9.13 General Purpose n

**Name:** GPn  
**Offset:** 0x40 + n\*0x04 [n=0..3]  
**Reset:** 0x00000000  
**Property:** -

Bit	31	30	29	28	27	26	25	24
	GP[31:24]							
Access	R/W	R/W	R/W	R/W	R/W	R/W	R/W	R/W
Reset	0	0	0	0	0	0	0	0
Bit	23	22	21	20	19	18	17	16
	GP[23:16]							
Access	R/W	R/W	R/W	R/W	R/W	R/W	R/W	R/W
Reset	0	0	0	0	0	0	0	0
Bit	15	14	13	12	11	10	9	8
	GP[15:8]							
Access	R/W	R/W	R/W	R/W	R/W	R/W	R/W	R/W
Reset	0	0	0	0	0	0	0	0
Bit	7	6	5	4	3	2	1	0
	GP[7:0]							
Access	R/W	R/W	R/W	R/W	R/W	R/W	R/W	R/W
Reset	0	0	0	0	0	0	0	0

#### Bits 31:0 – GP[31:0] General Purpose

These bits are for user-defined general purpose use, see [23.6.8.4. General Purpose Registers](#).

## 23.9.14 Tamper Control

**Name:** TAMPCTRL  
**Offset:** 0x60  
**Reset:** 0x00000000  
**Property:** PAC Write-Protection, Enable-Protected

Bit	31	30	29	28	27	26	25	24
				DEBNC4	DEBNC3	DEBNC2	DEBNC1	DEBNC0
Access								
Reset				0	0	0	0	0
Bit	23	22	21	20	19	18	17	16
				TAMLVL4	TAMLVL3	TAMLVL2	TAMLVL1	TAMLVL0
Access								
Reset				0	0	0	0	0
Bit	15	14	13	12	11	10	9	8
							IN4ACT[1:0]	
Access								
Reset							0	0
Bit	7	6	5	4	3	2	1	0
	IN3ACT[1:0]		IN2ACT[1:0]		IN1ACT[1:0]		IN0ACT[1:0]	
Access								
Reset	0	0	0	0	0	0	0	0

**Bits 24, 25, 26, 27, 28 – DEBNCn** Debounce Enable of Tamper Input INn [n=0..3]

**Note:** Debounce feature does not apply to the Active Layer Protection mode (TAMPCTRL.INACT = ACTL).

Value	Description
0	Debouncing is disabled for Tamper input INn
1	Debouncing is enabled for Tamper input INn

**Bits 16, 17, 18, 19, 20 – TAMLVLn** Tamper Level Select of Tamper Input INn [n=0..3]

**Note:** Tamper Level feature does not apply to the Active Layer Protection mode (TAMPCTRL.INACT = ACTL).

Value	Description
0	A falling edge condition will be detected on Tamper input INn.
1	A rising edge condition will be detected on Tamper input INn.

**Bits 0:1, 2:3, 4:5, 6:7, 8:9 – INnACT** Tamper Channel n Action [n=0..3]

These bits determine the action taken by Tamper Channel n.

Value	Name	Description
0x0	OFF	Off (Disabled)
0x1	WAKE	Wake and set Tamper flag
0x2	CAPTURE	Capture timestamp and set Tamper flag
0x3	ACTL	Compare RTC signal routed between INn and OUT pins . When a mismatch occurs, capture timestamp and set Tamper flag

## 23.9.15 Timestamp Value

**Name:**       TIMESTAMP  
**Offset:**     0x64  
**Reset:**       0  
**Property:**   -

**Note:** If an external reset occurs during a tamper detection the TIMESTAMP register is permanently locked until the next power up. To avoid that specific situation do not use the timestamp register and DMA upload, instead enable the RTC tamper interrupt, and in the tamper `irq` routine, copy the value from the RTC CLOCK register to one of the following destinations: SRAM, RTC GPx or BKUPx registers as the timestamp value.

Bit	31	30	29	28	27	26	25	24
	YEAR[5:0]					MONTH[3:2]		
Access	R	R	R	R	R	R	R	R
Reset	0	0	0	0	0	0	0	0
Bit	23	22	21	20	19	18	17	16
	MONTH[1:0]		DAY[4:0]				HOUR[4]	
Access	R	R	R	R	R	R	R	R
Reset	0	0	0	0	0	0	0	0
Bit	15	14	13	12	11	10	9	8
	HOUR[3:0]			MINUTE[5:2]				
Access	R	R	R	R	R	R	R	R
Reset	0	0	0	0	0	0	0	0
Bit	7	6	5	4	3	2	1	0
	MINUTE[1:0]		SECOND[5:0]					
Access	R	R	R	R	R	R	R	R
Reset	0	0	0	0	0	0	0	0

### Bits 31:26 – YEAR[5:0] Year

The year value is captured by the TIMESTAMP when a tamper condition occurs.

### Bits 25:22 – MONTH[3:0] Month

The month value is captured by the TIMESTAMP when a tamper condition occurs.

### Bits 21:17 – DAY[4:0] Day

The day value is captured by the TIMESTAMP when a tamper condition occurs.

### Bits 16:12 – HOUR[4:0] Hour

The hour value is captured by the TIMESTAMP when a tamper condition occurs.

### Bits 11:6 – MINUTE[5:0] Minute

The minute value is captured by the TIMESTAMP when a tamper condition occurs.

### Bits 5:0 – SECOND[5:0] Second

The second value is captured by the TIMESTAMP when a tamper condition occurs.

### 23.9.16 Tamper ID

**Name:** TAMPID  
**Offset:** 0x68  
**Reset:** 0x00000000

Bit	31	30	29	28	27	26	25	24
	TAMPEVT							
Access	R/W							
Reset	0							
Bit	23	22	21	20	19	18	17	16
Access								
Reset								
Bit	15	14	13	12	11	10	9	8
Access								
Reset								
Bit	7	6	5	4	3	2	1	0
				TAMPID4	TAMPID3	TAMPID2	TAMPID1	TAMPID0
Access				R/W	R/W	R/W	R/W	R/W
Reset				0	0	0	0	0

#### Bit 31 – TAMPEVT Tamper Event Detected

Writing a '0' to this bit has no effect. Writing a '1' to this bit clears the tamper detection bit.

Value	Description
0	A tamper input event has not been detected
1	A tamper input event has been detected

#### Bits 0, 1, 2, 3, 4 – TAMPIDn Tamper on Channel n Detected [n=0..3]

Writing a '0' to this bit has no effect. Writing a '1' to this bit clears the tamper detection bit.

Value	Description
0	A tamper condition has not been detected on Channel n
1	A tamper condition has been detected on Channel n

### 23.9.17 Backup n

**Name:** BKUP  
**Offset:** 0x80 + n\*0x04 [n=0..7]  
**Reset:** 0x00000000  
**Property:** PAC Write-Protection

Bit	31	30	29	28	27	26	25	24
	BKUP[31:24]							
Access	R/W	R/W	R/W	R/W	R/W	R/W	R/W	R/W
Reset	0	0	0	0	0	0	0	0
Bit	23	22	21	20	19	18	17	16
	BKUP[23:16]							
Access	R/W	R/W	R/W	R/W	R/W	R/W	R/W	R/W
Reset	0	0	0	0	0	0	0	0
Bit	15	14	13	12	11	10	9	8
	BKUP[15:8]							
Access	R/W	R/W	R/W	R/W	R/W	R/W	R/W	R/W
Reset	0	0	0	0	0	0	0	0
Bit	7	6	5	4	3	2	1	0
	BKUP[7:0]							
Access	R/W	R/W	R/W	R/W	R/W	R/W	R/W	R/W
Reset	0	0	0	0	0	0	0	0

#### Bits 31:0 – BKUP[31:0] Backup

These bits are user-defined for general purpose use in the Backup domain.

## 24. Frequency Meter (FREQM)

### 24.1 Overview

The Frequency Meter (FREQM) can be used to accurately measure the frequency of a clock by comparing it to a known reference clock.

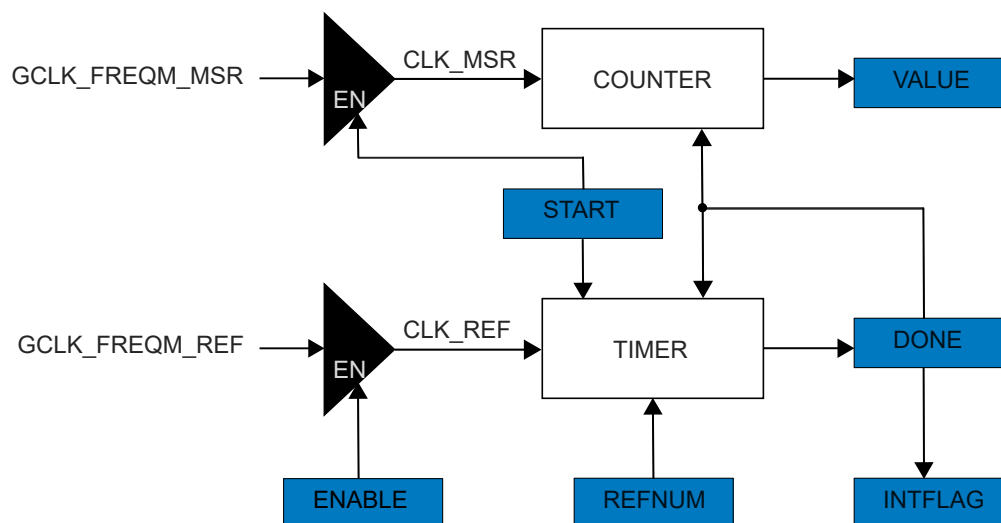
### 24.2 Features

The following are key features of the FREQM:

- Ratio can be measured with 24-bit accuracy
- Accurately measures the frequency of an input clock with respect to a reference clock
- Reference clock can be selected from the available GCLK\_FREQM\_REF sources
- Measured clock can be selected from the available GCLK\_FREQM\_MSR sources

### 24.3 Block Diagram

Figure 24-1. FREQM Block Diagram



### 24.4 Peripheral Dependencies

<b>Peripheral Name</b>	FREQM – Frequency Meter
<b>Base Address</b>	0x4000_2C00 (Peripheral Bus A)
<b>NVIC IRQ Index:Source</b>	28 : DONE
<b>MCLK APB Clock (1)</b>	CLK_FREQM_APB, Disabled, APBAMASK.FREQM
<b>GCLK Peripheral Channel Index:Clock Name (2)</b>	5 : GCLK_FREQM_MSR (FREQM Measure) 6 : GCLK_FREQM_REF (FREQM Reference)
<b>PAC Peripheral Peripheral Identifier (PAC.WRCTRL)</b>	11

**Notes:**

1. Clock Name, Default State, Mask Field.
2. See GCLK.PCHCTRLm Register, where m = Index.

**24.4.1 I/O Lines**

The GCLK I/O lines (GCLK\_IO[4:0]) can be used as measurement or reference clock sources. This requires the I/O pins to be configured.

**24.4.2 Power Management**

The FREQM will continue to operate in idle sleep mode where the selected source clock is running. The FREQM's interrupts can be used to wake up the device from idle sleep mode. Refer to the [Power Manager](#) chapter for details on the different sleep modes.

**24.4.3 Clocks**

The clock for the FREQM bus interface (CLK\_FREQM\_APB) is enabled and disabled by the [Main Clock Controller](#), the default state of CLK\_APB\_FREQM can be found in [Peripheral Clock Masking](#).

Two generic clocks are used by the FREQM: Reference Clock (GCLK\_FREQM\_REF) and Measurement Clock (GCLK\_FREQM\_MSR).

GCLK\_FREQM\_REF is required to clock the internal reference timer, which acts as the frequency reference.

GCLK\_FREQM\_MSR is required to clock a ripple counter for frequency measurement. These clocks must be configured and enabled in the generic clock controller before using the FREQM.

**24.4.4 Debug Operation**

When the CPU is halted in debug mode the FREQM continues its normal operation. The FREQM cannot be halted when the CPU is halted in debug mode. If the FREQM is configured in a way that requires it to be periodically serviced by the CPU, improper operation or data loss may result during debugging.

**24.4.5 Register Access Protection**

All registers with write access can be write-protected optionally by the [Peripheral Access Controller \(PAC\)](#), except the following registers:

- Control B register ([CTRLB](#))
- Interrupt Flag Status and Clear register ([INTFLAG](#))
- Status register ([STATUS](#))

Optional write protection by the [Peripheral Access Controller \(PAC\)](#) is denoted by the "PAC Write Protection" property in each individual register description.

Write-protection does not apply to accesses through an external debugger.

**24.5 Functional Description****24.5.1 Principle of Operation**

FREQM counts the number of periods of the measured clock (GCLK\_FREQM\_MSR) with respect to the reference clock (GCLK\_FREQM\_REF). The measurement is done for a period of  $\text{REFNUM}/f_{\text{CLK\_REF}}$  and stored in the Value register (VALUE.VALUE). REFNUM is the number of Reference clock cycles selected in the Configuration A register (CFG.A.REFNUM).

The frequency of the measured clock,  $f_{\text{CLK\_MSR}}$ , is calculated by



$f_{CLK\_MSR} = \left( \frac{VALUE + 1 + Error}{REFNUM + 1} \right) f_{CLK\_REF}$ , where Error represents the error introduced by the synchronization mechanism. The error can be maximum two measured clock cycles.

## 24.5.2 Basic Operation

### 24.5.2.1 Initialization

Before enabling FREQM, the device and peripheral must be configured:

- Each of the generic clocks (GCLK\_FREQM\_REF and GCLK\_FREQM\_MSR) must be configured and enabled.



**Important:** The reference clock must be slower than the measurement clock.

- Write the number of Reference clock cycles for which the measurement is to be done in the Configuration A register (CFGA.REFNUM). This must be a non-zero number.

The following register is enable-protected, meaning that it can only be written when the FREQM is disabled (CTRLA.ENABLE = 0):

- Configuration A register (CFGA)

Enable-protection is denoted by the "Enable-Protected" property in the register description.

### 24.5.2.2 Enabling, Disabling and Resetting

The FREQM is enabled by writing a '1' to the Enable bit in the Control A register (CTRLA.ENABLE). The peripheral is disabled by writing CTRLA.ENABLE = 0.

The FREQM is reset by writing a '1' to the Software Reset bit in the Control A register (CTRLA.SWRST). On software reset, all registers in the FREQM will be reset to their initial state, and the FREQM will be disabled.

Then ENABLE and SWRST bits are write-synchronized.

### 24.5.2.3 Measurement

In the Configuration A register, the Number of Reference Clock Cycles field (CFGA.REFNUM) selects the duration of the measurement. The measurement is given in number of GCLK\_FREQM\_REF periods.

**Note:** The REFNUM field must be written before the FREQM is enabled.

After the FREQM is enabled, writing a '1' to the START bit in the Control B register (CTRLB.START) starts the measurement. The BUSY bit in Status register (STATUS.BUSY) is set when the measurement starts, and cleared when the measurement is complete.

There is also an interrupt request for Measurement Done: When the Measurement Done bit in Interrupt Enable Set register (INTENSET.DONE) is '1' and a measurement is finished, the Measurement Done bit in the Interrupt Flag Status and Clear register (INTFLAG.DONE) will be set and an interrupt request is generated.

The result of the measurement can be read from the Value register (VALUE.VALUE). The frequency of the measured clock GCLK\_FREQM\_MSR is then:

$$f_{CLK\_MSR} = \left( \frac{VALUE + 1 + Error}{REFNUM + 1} \right) f_{CLK\_REF}$$

**Notes:**

1. In order to make sure the measurement result (`VALUE.VALUE[23:0]`) is valid, the overflow status (`STATUS.OVF`) should be checked.
2. Due to asynchronous operations, the VALUE Error measurement can be up to two samples.

In case an overflow condition occurred, indicated by the Overflow bit in the STATUS register (`STATUS.OVF`), either the number of reference clock cycles must be reduced (`CFG.A.REFNUM`), or a faster reference clock must be configured. Once the configuration is adjusted, clear the overflow status by writing a '1' to `STATUS.OVF`. Then another measurement can be started by writing a '1' to `CTRLB.START`.

**24.5.3 Interrupts**

The FREQM has one interrupt source:

- DONE: A frequency measurement is done.

The interrupt flag in the Interrupt Flag Status and Clear (`INTFLAG`) register is set when the interrupt condition occurs. The interrupt can be enabled by writing a '1' to the corresponding bit in the Interrupt Enable Set (`INTENSET`) register, and disabled by writing a '1' to the corresponding bit in the Interrupt Enable Clear (`INTENCLR`) register. The status of enabled interrupts can be read from either `INTENSET` or `INTENCLR`.

An interrupt request is generated when the interrupt flag is set and the corresponding interrupt is enabled. The interrupt request remains active until the interrupt flag is cleared, the interrupt is disabled, or the FREQM is reset. See `INTFLAG` for details on how to clear interrupt flags. All interrupt requests from the peripheral are ORed together on system level to generate one combined interrupt request to the NVIC. The user must read the `INTFLAG` register to determine which interrupt condition is present.

This interrupt is a synchronous wake-up source.

Note that interrupts must be globally enabled for interrupt requests to be generated.

**24.5.4 Sleep Mode Operation**

The FREQM will continue to operate in Idle Sleep mode where the selected source clock is running. The FREQM's interrupts can be used to wake up the device from Idle Sleep mode.

For lowest chip power consumption in sleep modes, FREQM should be disabled before entering a Sleep mode.

**24.5.5 Synchronization**

Due to asynchronicity between the main clock domain and the peripheral clock domains, some registers need to be synchronized when written or read:

The following bits and registers are write-synchronized:

- Software Reset bit in Control A register (`CTRLA.SWRST`)
- Enable bit in Control A register (`CTRLA.ENABLE`)

Required write synchronization is denoted by the "Write-Synchronized" property in the register description.

## 24.6 Register Summary

Offset	Name	Bit Pos.	7	6	5	4	3	2	1	0
0x00	CTRLA	7:0							ENABLE	SWRST
0x01	CTRLB	7:0								START
0x02	CFGA	7:0	REFNUM[7:0]							
		15:8								
0x04	Reserved									
...										
0x07										
0x08	INTENCLR	7:0								DONE
0x09	INTENSET	7:0								DONE
0x0A	INTFLAG	7:0								DONE
0x0B	STATUS	7:0							OVF	BUSY
									ENABLE	SWRST
0x0C	SYNCBUSY	7:0								
		15:8								
		23:16								
0x10	VALUE	31:24								
		7:0	VALUE[7:0]							
		15:8	VALUE[15:8]							
		23:16	VALUE[23:16]							
		31:24								

## 24.6.1 Control A

**Name:** CTRLA  
**Offset:** 0x00  
**Reset:** 0x00  
**Property:** PAC Write-Protection

Bit	7	6	5	4	3	2	1	0
							ENABLE	SWRST
Access							R/W	R/W
Reset							0	0

### Bit 1 – ENABLE Enable

Due to synchronization there is delay from writing CTRLA.ENABLE until the peripheral is enabled or disabled. The value written to CTRLA.ENABLE will read back immediately and the ENABLE bit in the Synchronization Busy register (SYNCBUSY.ENABLE) will be set. SYNCBUSY.ENABLE will be cleared when the operation is complete.

Value	Description
0	The peripheral is disabled.
1	The peripheral is enabled.

### Bit 0 – SWRST Software Reset

Writing a '0' to this bit has no effect.

Writing a '1' to this bit resets all registers in the FREQM to their initial state, and the FREQM will be disabled. Writing a '1' to this bit will always take precedence, meaning that all other writes in the same write-operation will be discarded.

Due to synchronization there is a delay from writing CTRLA.SWRST until the Reset is complete. CTRLA.SWRST and SYNCBUSY.SWRST will be cleared when the Reset is complete.

#### Notes:

1. When the CTRLA.SWRST is written, the user must poll the SYNCBUSY.SWRST bit to know when the reset operation is complete.
2. During a SWRST, access to registers or bits without the SWRST are disallowed until the SYNCBUSY.SWRST is cleared by hardware.

Value	Description
0	There is no ongoing Reset operation.
1	The Reset operation is ongoing.

## 24.6.2 Control B

**Name:** CTRLB  
**Offset:** 0x01  
**Reset:** 0x00  
**Property:** -

**Note:** Writing the Frequency Meter Control B register (FREQM.CTRLB) will result in a PAC error which must be ignored.

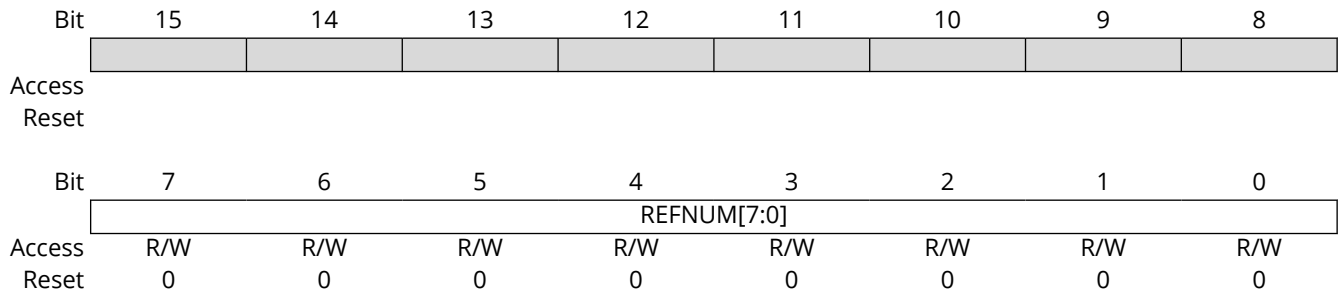
Bit	7	6	5	4	3	2	1	0
								START
Access								W
Reset								0

### Bit 0 – START Start Measurement

Value	Description
0	Writing a '0' has no effect.
1	Writing a '1' starts a measurement.

### 24.6.3 Configuration A

**Name:** CFGA  
**Offset:** 0x02  
**Reset:** 0x0000  
**Property:** PAC Write-Protection, Enable-protected



**Bits 7:0 – REFNUM[7:0]** Number of Reference Clock Cycles  
 Selects the duration of a measurement in number of CLK\_FREQM\_REF cycles. This must be a non-zero value, i.e. 0x01 (one cycle) to 0xFF (255 cycles).

## 24.6.4 Interrupt Enable Clear

**Name:** INTENCLR  
**Offset:** 0x08  
**Reset:** 0x00  
**Property:** PAC Write-Protection

Bit	7	6	5	4	3	2	1	0
								DONE
Access								R/W
Reset								0

### Bit 0 – DONE Measurement Done Interrupt Enable

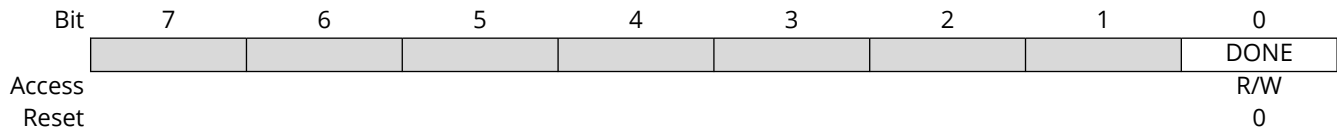
Writing a '0' to this bit has no effect.

Writing a '1' to this bit will clear the Measurement Done Interrupt Enable bit, which disables the Measurement Done interrupt.

Value	Description
0	The Measurement Done interrupt is disabled.
1	The Measurement Done interrupt is enabled.

### 24.6.5 Interrupt Enable Set

**Name:** INTENSET  
**Offset:** 0x09  
**Reset:** 0x00  
**Property:** PAC Write-Protection



#### Bit 0 – DONE Measurement Done Interrupt Enable

Writing a '0' to this bit has no effect.

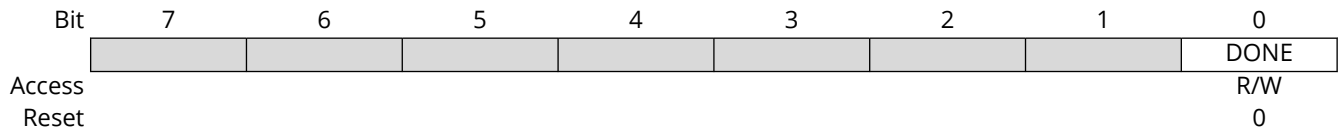
Writing a '1' to this bit will set the Measurement Done Interrupt Enable bit, which enables the Measurement Done interrupt.

Value	Description
0	The Measurement Done interrupt is disabled.
1	The Measurement Done interrupt is enabled.



## 24.6.6 Interrupt Flag Status and Clear

**Name:** INTFLAG  
**Offset:** 0x0A  
**Reset:** 0x00  
**Property:** -



### Bit 0 - DONE Measurement Done

This flag is cleared by writing a '1' to it.

This flag is set when the STATUS.BUSY bit has a one-to-zero transition.

Writing a '0' to this bit has no effect.

Writing a '1' to this bit will clear the DONE interrupt flag.

## 24.6.7 Status

**Name:** STATUS  
**Offset:** 0x0B  
**Reset:** 0x00  
**Property:** -

Bit	7	6	5	4	3	2	1	0
							OVF	BUSY
Access							R/W	R
Reset							0	0

### Bit 1 - OVF Sticky Count Value Overflow

This bit is cleared by writing a '1' to it.

This bit is set when an overflow condition occurs to the value counter.

Writing a '0' to this bit has no effect.

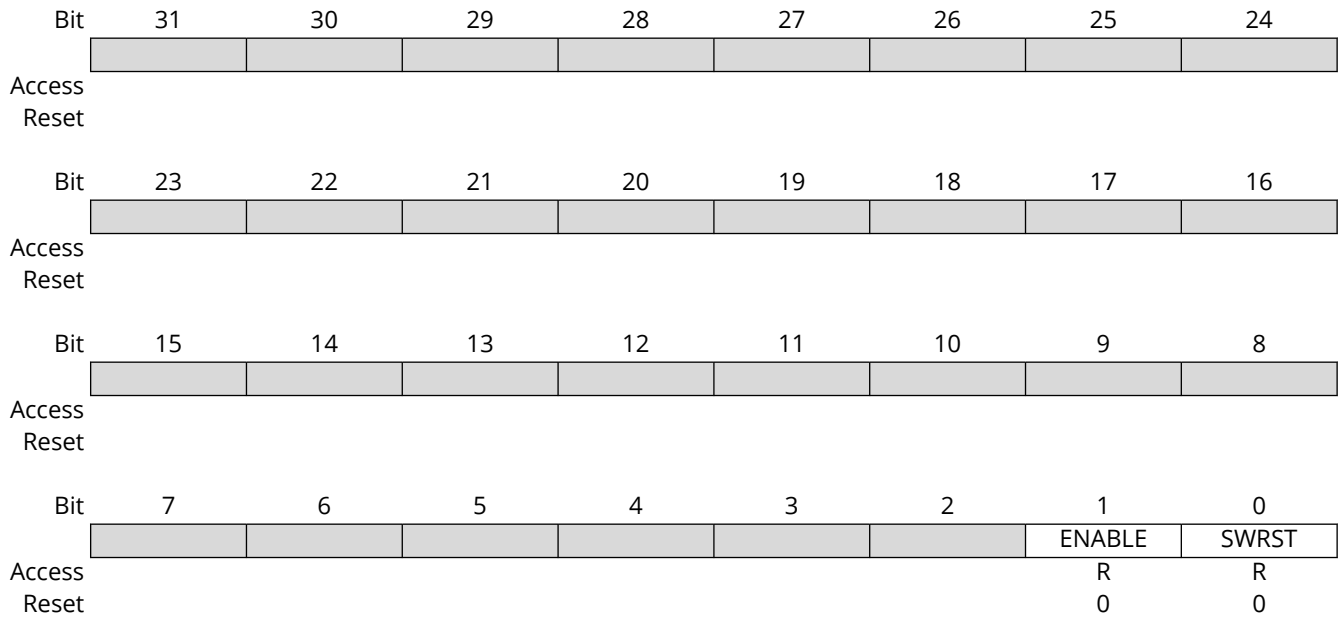
Writing a '1' to this bit will clear the OVF status.

### Bit 0 - BUSY FREQM Status

Value	Description
0	No ongoing frequency measurement.
1	Frequency measurement is ongoing.

## 24.6.8 Synchronization Busy

**Name:** SYNCBUSY  
**Offset:** 0x0C  
**Reset:** 0x00000000  
**Property:** -



### Bit 1 - ENABLE Enable

This bit is cleared when the synchronization of CTRLA.ENABLE is complete.  
 This bit is set when the synchronization of CTRLA.ENABLE is started.

### Bit 0 - SWRST Synchronization Busy

This bit is cleared when the synchronization of CTRLA.SWRST is complete.  
 This bit is set when the synchronization of CTRLA.SWRST is started.

## 24.6.9 Value

**Name:** VALUE  
**Offset:** 0x10  
**Reset:** 0x00000000  
**Property:** -

Bit	31	30	29	28	27	26	25	24
Access								
Reset								
Bit	23	22	21	20	19	18	17	16
	VALUE[23:16]							
Access	R	R	R	R	R	R	R	R
Reset	0	0	0	0	0	0	0	0
Bit	15	14	13	12	11	10	9	8
	VALUE[15:8]							
Access	R	R	R	R	R	R	R	R
Reset	0	0	0	0	0	0	0	0
Bit	7	6	5	4	3	2	1	0
	VALUE[7:0]							
Access	R	R	R	R	R	R	R	R
Reset	0	0	0	0	0	0	0	0

**Bits 23:0 - VALUE[23:0]** Measurement Value  
 Result from measurement.

## 25. Direct Memory Access Controller (DMAC)

### 25.1 Overview

The Direct Memory Access Controller (DMAC) contains both a Direct Memory Access engine and a Cyclic Redundancy Check (CRC) engine. The DMAC can transfer data between memories and peripherals, and thus off-load these tasks from the CPU. It enables high data transfer rates with minimum CPU intervention, and frees up CPU time. With access to all peripherals, the DMAC can handle automatic transfer of data between communication modules.

The DMA part of the DMAC has several DMA channels which can receive different types of transfer triggers to generate transfer requests from the DMA channels to the arbiter (see the [Block Diagram](#)). The arbiter will select one DMA channel at a time to act as the active channel. When an active channel has been granted, the fetch engine of the DMAC will fetch a transfer descriptor from the SRAM and store it in the internal memory of the active channel, which will then execute the data transmission.

An ongoing data transfer of an active channel can be interrupted by a higher prioritized DMA channel. The DMAC will write back the updated transfer descriptor from the internal memory of the active channel to SRAM, and grant the higher prioritized channel to start transfer as the new active channel. Once a DMA channel is done with its transfer, interrupts and events can be generated optionally.

The DMAC has the following bus interfaces:

- The data transfer bus – Used for performing the actual DMA transfer.
- The AHB/APB Bridge bus – Used when writing and reading the I/O registers of the DMAC.
- The descriptor fetch bus – Used by the fetch engine to fetch transfer descriptors before data transfer can be started or continued.
- The write-back bus – Used to write the transfer descriptor back to SRAM.

All buses are AHB Host interfaces except for the AHB/APB Bridge bus, which is an APB Client interface.

Burst transfer options, buffered active channel to pre-fetch descriptors and advance quality of service features ensure low-latency transfers for high-speed peripherals or high-speed operations.

The CRC engine can be used by software to detect an accidental error in the transferred data and to take corrective action, such as requesting the data to be sent again or simply not using the incorrect data.

### 25.2 Features

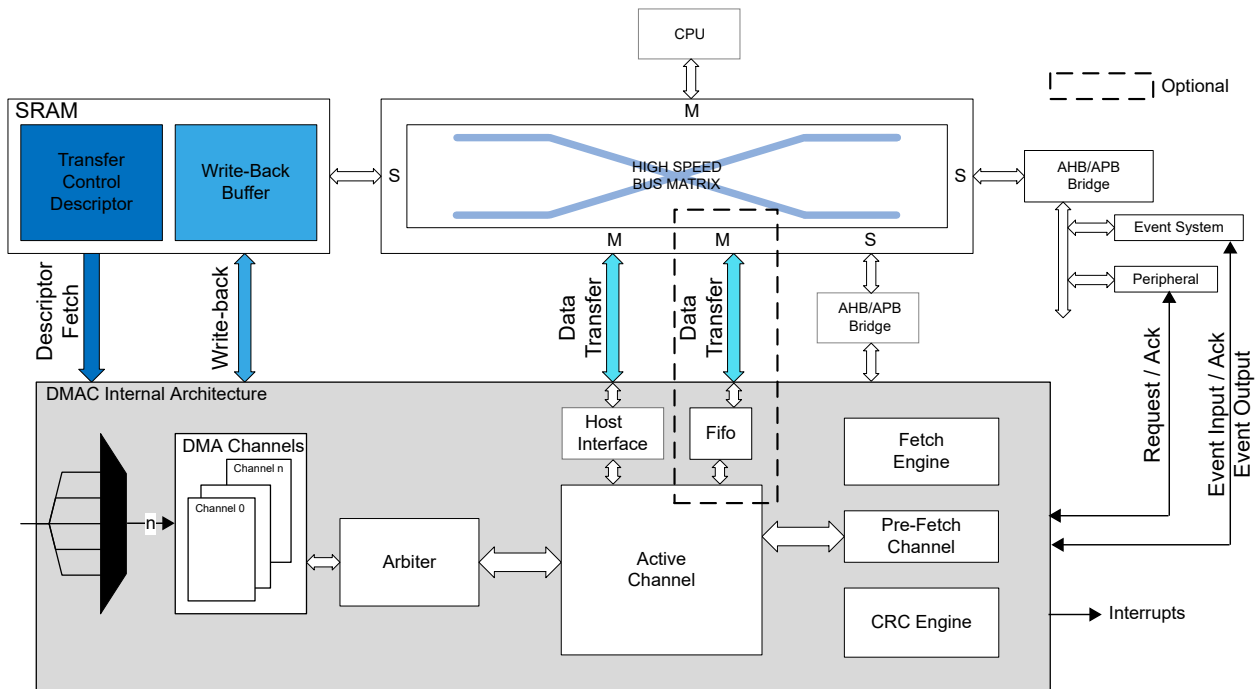
The following are key features of the DMAC:

- Data transfer from:
  - Peripheral to peripheral
  - Peripheral to memory
  - Memory to peripheral
  - Memory to memory
- Transfer trigger sources
  - Software
  - Events from Event System
  - Dedicated requests from peripherals
- SRAM based transfer descriptors

- Single transfer using one descriptor
  - Multi-buffer or circular buffer modes by linking multiple descriptors
- Up to 32 channels
  - Enable 32 independent transfers
  - Automatic descriptor fetch for each channel
  - Suspend/resume operation support for each channel
- Flexible arbitration scheme
  - 4 configurable priority levels for each channel
  - Fixed or round-robin priority scheme within each priority level
- From 1 to 256 KB data transfer in a single block transfer
- Multiple addressing modes
  - Static
  - Configurable increment scheme
- Optional interrupt generation
  - On block transfer complete
  - On error detection
  - On channel suspend
- 8 event inputs
  - One event input for each of the 8 least significant DMA channels
  - Can be selected to trigger normal transfers, periodic transfers or conditional transfers
  - Can be selected to suspend or resume channel operation
- 4 event outputs
  - One output event for each of the 4 least significant DMA channels
  - Selectable generation on AHB, block, or transaction transfer complete
- Error management supported by write-back function
  - Dedicated Write-Back memory section for each channel to store ongoing descriptor transfer
- CRC polynomial software selectable to
  - CRC-16 (CRC-CCITT)
  - CRC-32 (IEEE® 802.3)

## 25.3 Block Diagram

Figure 25-1. DMAC Block Diagram



## 25.4 Peripheral Dependencies

<b>Peripheral Name</b>	DMAC – Direct Memory Access Controller
<b>Base Address</b>	0x4100_A000 (Peripheral Bus B)
<b>NVIC IRQ Index:Source</b>	31 : SUSP0, TCMPL0, TERR0 32 : SUSP1, TCMPL1, TERR1 33 : SUSP2, TCMPL2, TERR2 34 : SUSP3, TCMPL3, TERR3 35 : SUSP4..31, TCMPL4..31, TERR4..31
<b>MCLK APB Clock (1)</b>	CLK_DMCA_AHB, Enabled, AHBMASK.DMAC
<b>GCLK Peripheral Channel Index:Clock Name (2)</b>	n/a
<b>PAC Peripheral Identifier (PAC.WRCTRL)</b>	37
<b>DMA Trigger Index:Source (DMAC.CHCTRLAk,k=0,1,...31)</b>	n/a
<b>EVSYS Users (EVSYS.USERm) (3)</b>	5-12 : DMA Channel x, x=0..7 (DMAC_CH0..7) (S,R)
<b>EVSYS Generators (EVSYS.CHANNELn)</b>	34-37 : DMA Channel x, x=0..3 (DMAC_CHx)
<b>Notes:</b>	
1.	Clock Name, Default State, Mask Field.
2.	See GCLK.PCHCTRLm Register, where m = Index.
3.	(A,S,R): A = Asynchronous path, S = Synchronous path, R = Resynchronized path.

### 25.4.1 Power Management

The DMAC will continue to operate in IDLE 0 mode where the selected source clock is running. The DMAC's interrupts can be used to wake-up the device from Sleep modes. Events connected to the event system can trigger other operations in the system without exiting Sleep modes. On hardware or software Reset, all registers are set to their Reset value.

## 25.4.2 Clocks

An AHB clock (CLK\_DMACH\_AHB) is required to clock the DMAC. This clock can be configured in the [Main Clock peripheral \(MCLK\)](#) before using the DMAC, and the default state of CLK\_DMACH\_AHB can be found in the MCLK.AHBMASK register.

## 25.4.3 Debug Operation

When the CPU is halted in Debug mode the DMAC will halt normal operation. The DMAC can be forced to continue operation during debugging. Refer to [25.6.6. DBGCTRL](#) for details.

## 25.4.4 Register Access Protection

All registers with write access can be write-protected optionally by the [Peripheral Access Controller \(PAC\)](#), except for the following registers:

- Interrupt Pending register (INTPEND)
- Channel Interrupt Flag Status and Clear register (CHINTFLAG)

Optional write protection by the [Peripheral Access Controller \(PAC\)](#) is denoted by the "PAC Write Protection" property in each individual register description.

PAC write protection does not apply to accesses through an external debugger.

## 25.5 Functional Description

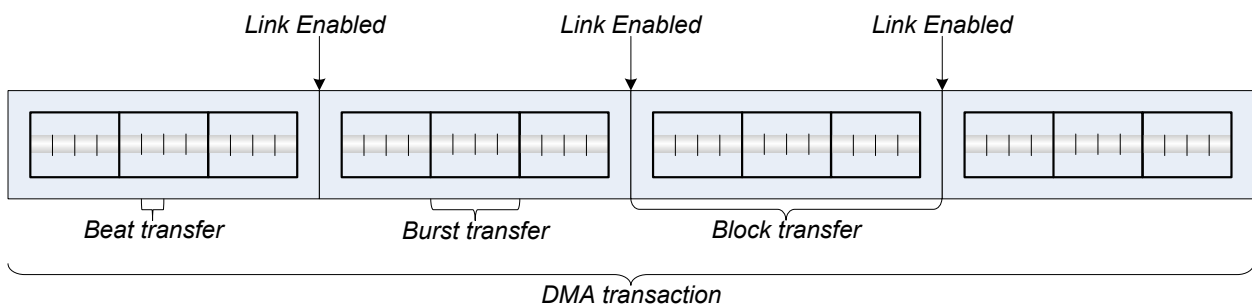
### 25.5.1 Principle of Operation

The DMAC consists of a DMA module and a CRC module.

#### 25.5.1.1 DMA

The DMAC can transfer data between memories and peripherals without interaction from the CPU. The data transferred by the DMAC are called transactions, and these transactions can be split into smaller data transfers. The following figure shows the relationship between the different transfer sizes:

Figure 25-2. DMA Transfer Sizes



- **Beat Transfer:** The size of one data transfer bus access, and the size is selected by writing the Beat Size bit group in the Block Transfer Control register (BTCTRL.BEATSIZE)
- **Block Transfer:** The amount of data one transfer descriptor can transfer, and the amount can range from 1 to 64k beats. A block transfer can be interrupted.
- **Burst Transfer:** Back-to-back beat transfers without CPU interference
- **Transaction:** The DMAC can link several transfer descriptors by having the first descriptor pointing to the second and so forth, as shown in the figure above. A DMA transaction is the complete transfer of all blocks within a linked list.

A transfer descriptor describes how a block transfer should be carried out by the DMAC, and it must remain in SRAM. For further details on the transfer descriptor refer to [25.5.2.3. Transfer Descriptors](#).



The figure above shows several block transfers linked together, which are called linked descriptors. For further information about linked descriptors, refer to [25.5.3.1. Linked Descriptors](#).

A DMA transfer is initiated by an incoming transfer trigger on one of the DMA channels. This trigger can be configured to be either a software trigger, an event trigger, or one of the dedicated peripheral triggers. The transfer trigger will result in a DMA transfer request from the specific channel to the arbiter. If there are several DMA channels with pending transfer requests, the arbiter chooses which channel is granted access to become the active channel. The DMA channel granted access as the active channel will carry out the transaction as configured in the transfer descriptor. A current transaction can be interrupted by a higher prioritized channel, but will resume the block transfer when the according DMA channel is granted access as the active channel again.

For each beat transfer, an optional output event can be generated. For each block transfer, optional interrupts and an optional output event can be generated. When a transaction is completed, depending on the configuration, the DMA channel will either be suspended or disabled.

### 25.5.1.2 CRC

The internal CRC engine supports two commonly used CRC polynomials: CRC-16 (CRC-CCITT) and CRC-32 (IEEE 802.3). It can be used on a selectable DMA channel, or on the I/O interface. Refer to [25.5.3.8. CRC Operation](#) for details.

## 25.5.2 Basic Operation

### 25.5.2.1 Initialization

#### DMAC Initialization

Before DMAC is enabled, it must be configured as defined below:

- The SRAM address of where the descriptor memory section is located must be written to the Description Base Address (BASEADDR) register.
- The SRAM address of where the write-back section should be located must be written to the Write-Back Memory Base Address (WRBADDR) register.
- Priority level x of the arbiter can be enabled by setting the Priority Level x Enable bit in the Control register (CTRL.LVLENx=1)

#### DMA Channel Initialization

Before a DMA channel is enabled, the DMA channel and the corresponding first transfer descriptor must be configured, as defined below:

- DMA Channel Configuration:
  - The channel number of the DMA channel to configure must be written to the Channel Control A (CHCTRLA) register.
  - Trigger action must be selected by writing the Trigger Action bit field in the Channel Control A (CHCTRLA.TRIGACT) register.
  - Trigger source must be selected by writing the Trigger Source bit field in the Channel Control A (CHCTRLA.TRIGSRC) register.
- Transfer Descriptor
  - The size of each access of the data transfer bus must be selected by writing the Beat Size bit group in the Block Transfer Control (BTCTRL.BEATSIZE) register.
  - The transfer descriptor must be made valid by writing a one to the Valid bit in the Block Transfer Control (BTCTRL.VALID) register.
  - Number of beats in the block transfer must be selected by writing the Block Transfer Count (BTCNT) register.
  - Source address for the block transfer must be selected by writing the Block Transfer Source Address (SRCADDR) register.

- Destination address for the block transfer must be selected by writing the Block Transfer Destination Address (DSTADDR) register.

### CRC Calculation

If CRC calculation is needed, the CRC engine must be configured before it is enabled, as described below:

- The CRC input source must be selected by writing the CRC Input Source bit group in the CRC Control (CRCCTRL.CRCSRC) register.
- The type of CRC calculation must be selected by writing the CRC Polynomial Type bit group in the CRC Control (CRCCTRL.CRCPOLY) register.
- If I/O is selected as input source, the beat size must be selected by writing the CRC Beat Size bit group in the CRC Control (CRCCTRL.CRCBEATSIZE) register.

### Register Properties

The following DMAC registers are enable-protected, that is, they can only be written when the DMAC is disabled (CTRL.DMAENABLE=0):

- The Descriptor Base Memory Address (BASEADDR) register
- The Write-Back Memory Base Address (WRBADDR) register

The following DMAC bit is enable-protected, that is, it can only be written when the DMAC and CRC are disabled (CTRL.DMAENABLE=0 and CRCCTRL.CRCSRC=0):

- The Software Reset bit in the Control (CTRL.SWRST) register

The following DMA channel bit is enable-protected, meaning that it can only be written when the corresponding DMA channel is disabled:

- The Channel Software Reset bit in the Channel Control A (CHCTRLA.SWRST) register

The following CRC registers are enable-protected, that is, they can only be written when the CRC is disabled (CRCCTRL.CRCSRC=0):

- The CRC Control (CRCCTRL) register
- CRC Checksum (CRCCHKSUM) register

Enable-protection is denoted by the 'Enable-Protected' property in the register description.

#### 25.5.2.2 Enabling, Disabling, and Resetting

The DMAC is enabled by writing the DMA Enable bit in the Control (CTRL.DMAENABLE) register to '1'. The DMAC is disabled by writing a '0' to the CTRL.DMAENABLE register.

A DMA channel is enabled by writing the Enable bit in the Channel Control A register (CHCTRLA.ENABLE) to '1', after the corresponding channel ID to the channel is configured. A DMA channel is disabled by writing a '0' to CHCTRLAn.ENABLE.

The CRC is enabled by writing a value to the CRC Source bits in the Control register (CRCCTRL.CRCSRC). The CRC is disabled by writing a '0' to CRCCTRL.CRCSRC.

The DMAC is reset by writing a '1' to the Software Reset bit in the Control register (CTRL.SWRST) while the DMAC and CRC are disabled. All registers in the DMAC except DBGCTRL will be reset to their initial state.

A DMA channel is reset by writing a '1' to the Software Reset bit in the Channel Control A register (CHCTRLAn.SWRST), after the corresponding channel is configured. The channel registers will be reset to their initial state. The corresponding DMA channel must be disabled in order for the Reset to take effect.

### 25.5.2.3 Transfer Descriptors

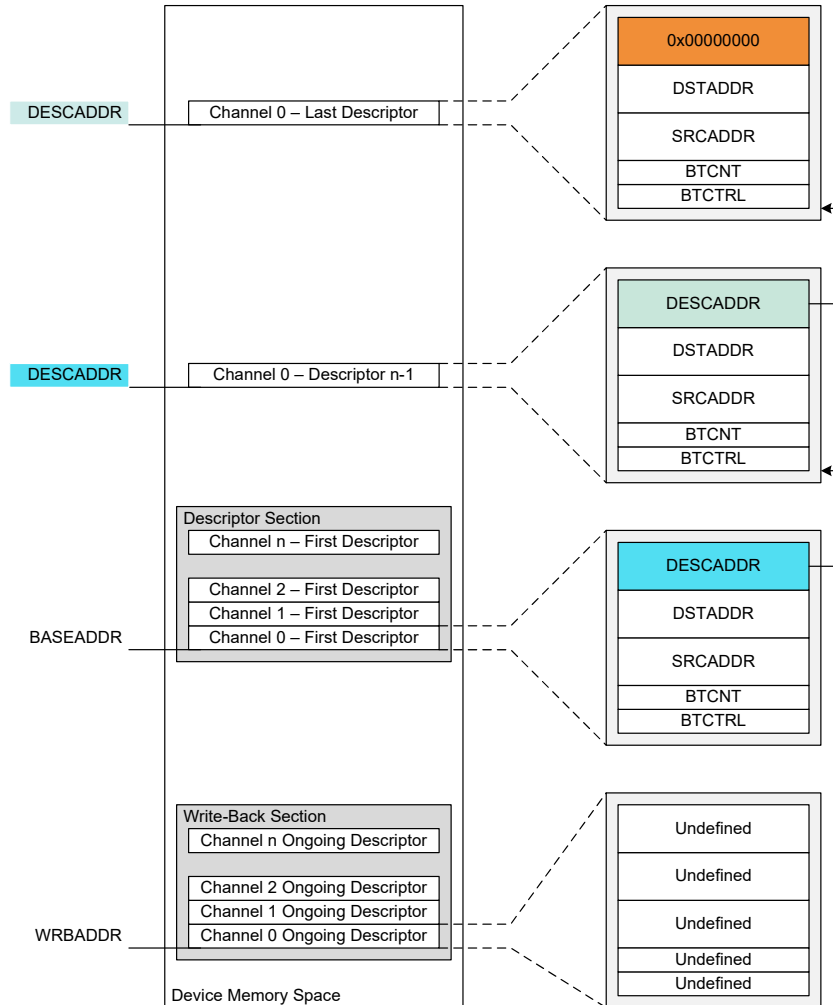
The transfer descriptors, together with the channel configurations, decide how a block transfer should be executed. Before a DMA channel is enabled (CHCTRLA.ENABLE is written to one) and receives a transfer trigger, its first transfer descriptor must be initialized and valid (BTCTRL.VALID). The first transfer descriptor describes the first block transfer of a transaction.

All transfer descriptors must reside in SRAM. The addresses stored in the Descriptor Memory Section Base Address (BASEADDR) and Write-Back Memory Section Base Address (WRBADDR) registers tell the DMAC where to find the descriptor memory section and the write-back memory section.

The descriptor memory section is where the DMAC expects to find the first transfer descriptors for all DMA channels. As BASEADDR points only to the first transfer descriptor of channel '0' (see figure below). All first transfer descriptors must be stored in a contiguous memory section, where the transfer descriptors must be ordered according to their channel number. For further details on linked descriptors, refer to [25.5.3.1. Linked Descriptors](#).

The write-back memory section is where the DMAC stores the transfer descriptors for the ongoing block transfers. WRBADDR points to the ongoing transfer descriptor of channel '0'. All ongoing transfer descriptors are stored in a contiguous memory section where the transfer descriptors are ordered according to their channel number. The figure below shows an example of linked descriptors on DMA channel '0'. For additional information on linked descriptors, refer to the [25.5.3.1. Linked Descriptors](#).

Figure 25-3. Memory Sections



The size of the descriptor and write-back memory sections are dependent on the number of the most significant enabled DMA channel  $m$ , as shown below:

$$Size = 128\text{bits} \cdot (m + 1)$$

For memory optimization, it is recommended to use the less significant DMA channels, if not all channels are required.

The descriptor and write-back memory sections can either be two separate memory sections, or they can share a memory section ( $BASEADDR=WRBADDR$ ). The benefit of having them in two separate sections, is that the same transaction for a channel can be repeated without having to modify the first transfer descriptor. In addition, the latency from fetching the first descriptor of a transaction to the first burst transfer is executed, is reduced.

#### 25.5.2.4 Arbitration

If a DMA channel is enabled and not suspended when it receives a transfer trigger, it will send a transfer request to the arbiter. When the arbiter receives the transfer request it will include the DMA channel in the queue of channels having pending transfers, and the corresponding Pending Channel  $x$  bit in the Pending Channels registers ( $PENDCH.PENDCHx$ ) will be set. Depending on the arbitration scheme, the arbiter will choose which DMA channel will be the next active channel. The next transfer descriptor will be fetched from SRAM memory and stored internally in the Pre-Fetch Channel. The active channel is the DMA channel being granted access to perform its next burst transfer. When

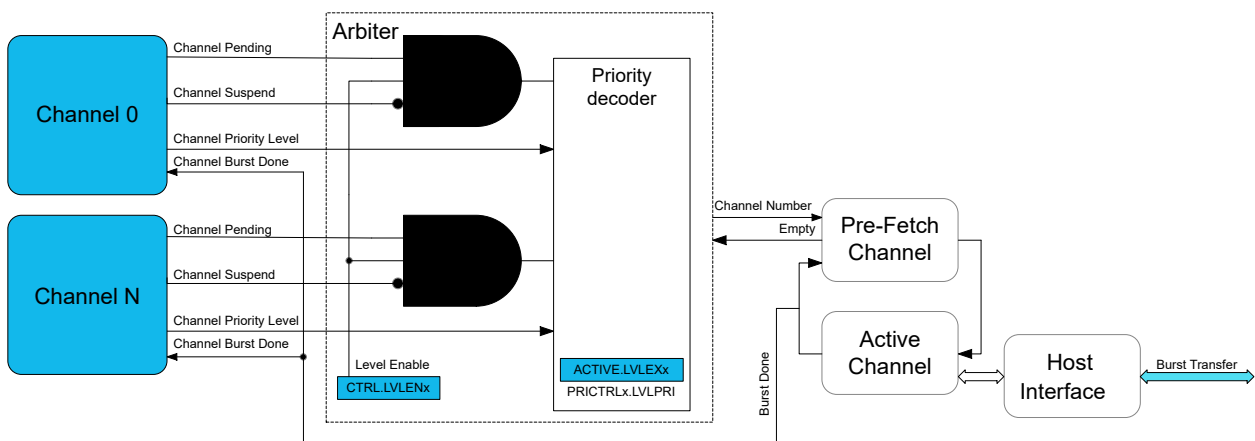
the Active Channel has completed a burst transfer, the descriptor stored in the Pre-Fetch Channel is transferred to the Active Channel and a new burst will take place.

When the descriptor stored in the Pre-Fetch Channel is transferred to the Active Channel, the corresponding PENDCH.PENDCHx will be cleared. In the same way, depending on trigger action settings and if the upcoming burst transfer is the first for the transfer request or not, the corresponding Busy Channel x bit in the Busy Channels register (BUSYCH.BUSYCHx), will either be set or remain '1'. When the channel has performed its granted burst transfer(s) it will be either fed into the queue of channels with pending transfers, set to be waiting for a new transfer trigger, suspended, or disabled. This depends on the channel and block transfer configuration. If the DMA channel is set to wait for a new transfer trigger, suspended or disabled, the corresponding BUSYCH.BUSYCHx will be cleared.

If a DMA channel is suspended while it has a pending transfer, it will be removed from the queue of pending channels, but the corresponding PENDCH.PENDCHx will remain set. The status will also be indicated in CHINTFLAGn.SUSP. When the same DMA channel is resumed, it will be added to the queue of pending channels again.

If a DMA channel gets disabled (CHCTRLA.ENABLE=0) while it has a pending transfer, it will be removed from the queue of pending channels, and the corresponding PENDCH.PENDCHx will be cleared.

**Figure 25-4. Arbiter Overview**



## Priority Levels

When a channel level is pending or the channel is transferring data, the corresponding Level Executing bit is set in the Active Channel and Levels register (ACTIVE.LVLEXx).

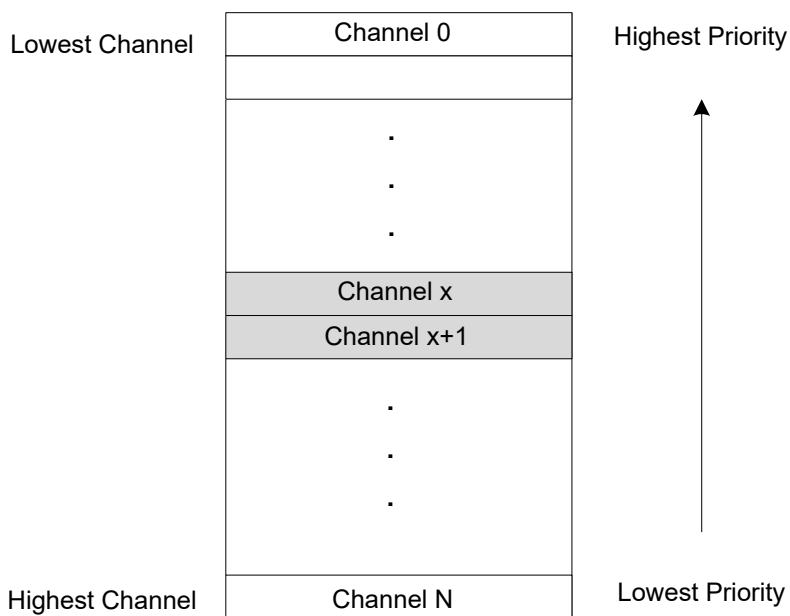
Each DMA channel supports up to 4-level priority scheme. The number of supported priority levels will differ from one device family to another.

The priority level for a channel is configured by writing to the Channel Arbitration Level bit group in the Channel Priority Level register (CHPRILVL.PRILVL). As long as all priority levels are enabled, a channel with a higher priority level number will have priority over a channel with a lower priority level number. A priority level is enabled by writing the Priority Level x Enable bit in the Control register (CTRL.LVLENx) to '1', for the corresponding level.

Within each priority level, the DMAC's arbiter can be configured to prioritize statically or dynamically. For the arbiter to perform static arbitration within a priority level, the Level X Round-Robin Scheduling Enable bit in the Priority Control x register (PRICTRL0.RRLVLENx) has to be written to '0'. When static arbitration is enabled (PRICTRL0.RRLVLENx is '0'), the arbiter will prioritize a low channel number over a high channel number as shown in the following figure. When using the static

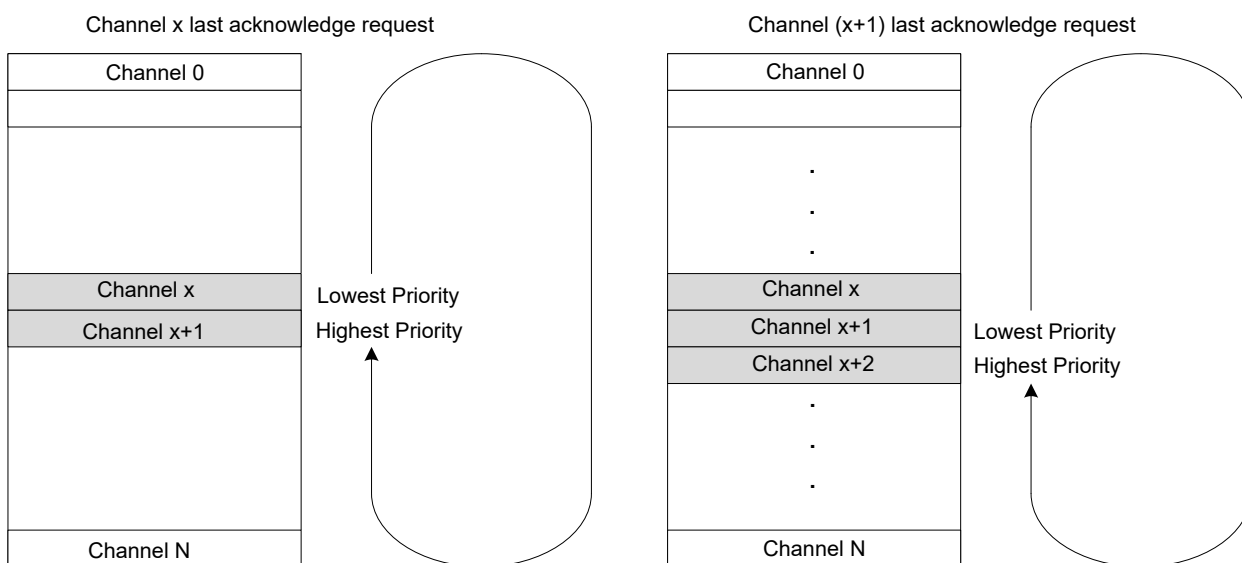
scheme, there is a risk of high channel numbers never being granted access as the active channel. This can be avoided using a dynamic arbitration scheme.

**Figure 25-5.** Static Priority Scheduling



The dynamic arbitration scheme in the DMAC is round-robin. Round-robin arbitration is enabled by writing `PRICTRL0.RRLVLENx` to '1', for a given priority level  $x$ . With the round-robin scheme, the channel number of the last channel being granted access will have the lowest priority the next time the arbiter has to grant access to a channel within the same priority level, as shown in the following figure, *Dynamic (Round-Robin) Priority Scheduling*. The channel number of the last channel being granted access as the active channel is stored in the Level  $x$  Channel Priority Number bit group in the Priority Control 0 register (`PRICTRL0.LVLPRix`) for the corresponding priority level.

**Figure 25-6.** Dynamic (Round-Robin) Priority Scheduling



### 25.5.2.5 Data Transmission

Before the DMAC can perform a data transmission, a DMA channel has to be configured and enabled, its corresponding transfer descriptor has to be initialized, and the arbiter has to grant the DMA channel access as the active channel.

Once the arbiter has granted a DMA channel access as the active channel (refer to DMA [Block Diagram](#) section) the transfer descriptor for the DMA channel will be fetched from SRAM using the fetch bus, and stored in the internal memory for the active channel. For a new block transfer, the transfer descriptor will be fetched from the descriptor memory section ([BASEADDR](#)); For an ongoing block transfer, the descriptor will be fetched from the write-back memory section ([WRBADDR](#)). By using the data transfer bus, the DMAC will read the data from the current source address and write it to the current destination address. For further details on how the current source and destination addresses are calculated, refer to the section on [Addressing](#).

The arbitration procedure is performed after each burst transfer. If the current DMA channel is granted access again, the block transfer counter ([BTCNT](#)) of the internal transfer descriptor will be decremented by the number of beats in a burst transfer, the optional output event Beat will be generated if configured and enabled, and the active channel will perform a new burst transfer. If a different DMA channel than the current active channel is granted access, the block transfer counter value will be written to the write-back section before the transfer descriptor of the newly granted DMA channel is fetched into the internal memory of the active channel.

When a block transfer has come to its end ([BTCNT](#) is zero), the Valid bit in the Block Transfer Control register will be cleared ([BTCTRL.VALID=0](#)) before the entire transfer descriptor is written to the write-back memory. The optional interrupts, Channel Transfer Complete and Channel Suspend, and the optional output event Block, will be generated if configured and enabled. After the last block transfer in a transaction, the Next Descriptor Address register ([DESCADDR](#)) will hold the value 0x00000000, and the DMA channel will either be suspended or disabled, depending on the configuration in the Block Action bit group in the Block Transfer Control register ([BTCTRL.BLOCKACT](#)). If the transaction has further block transfers pending, [DESCADDR](#) will hold the SRAM address to the next transfer descriptor to be fetched. The DMAC will fetch the next descriptor into the internal memory of the active channel and write its content to the write-back section for the channel, before the arbiter gets to choose the next active channel.

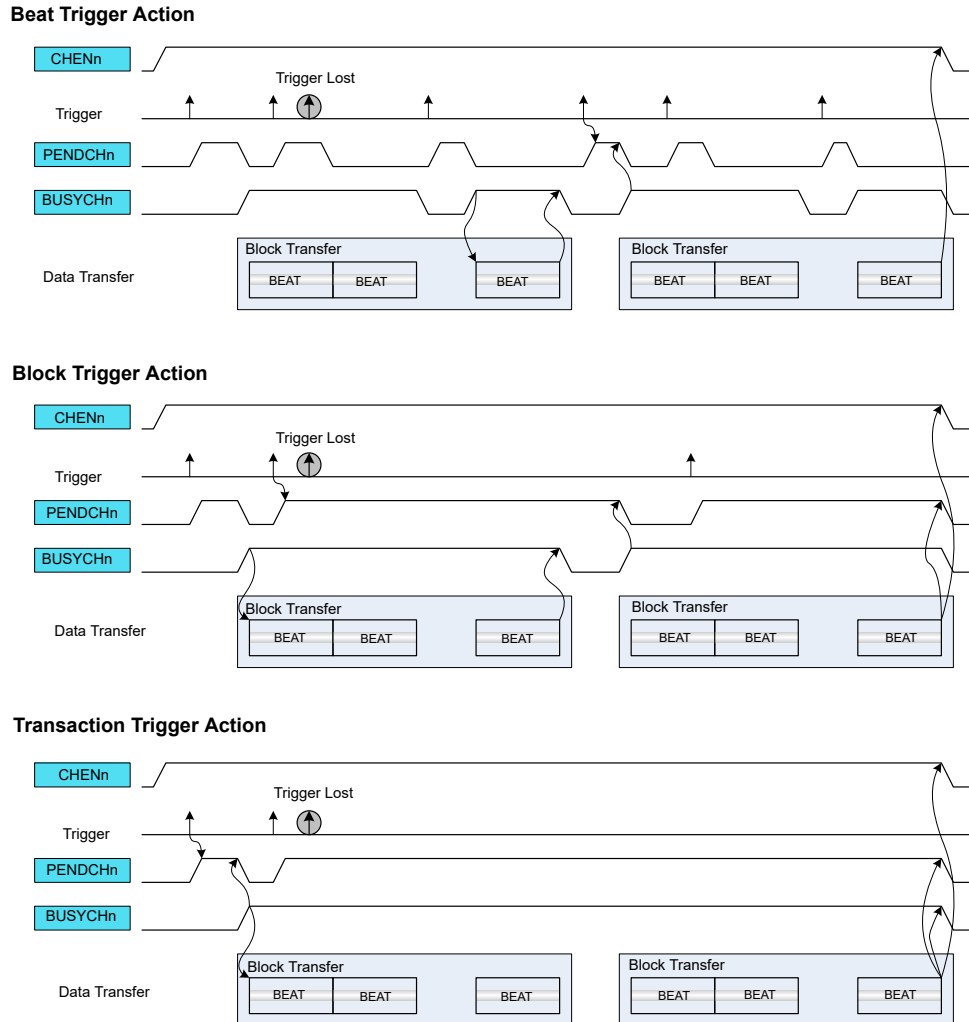
### 25.5.2.6 Transfer Triggers and Actions

A DMA transfer through a DMA channel can be started only when a DMA transfer request is detected, and the DMA channel has been granted access to the DMA. A transfer request can be triggered from software, from a peripheral, or from an event. There are dedicated Trigger Source selections for each DMA Channel n Control A ([CHCTRLAn.TRIGSRC](#)).

The trigger actions are available in the Trigger Action bit group in the Channel n Control A register ([CHCTRLAn.TRIGACT](#)). By default, a trigger generates a request for a block transfer operation. If a single descriptor is defined for a channel, the channel is automatically disabled when a block transfer has been completed. If a list of linked descriptors is defined for a channel, the channel is automatically disabled when the last descriptor in the list is executed. As long as the list still has descriptors to execute, the channel will be waiting for the next block transfer trigger. When enabled again, the channel will wait for the next block transfer trigger. The trigger actions can also be configured to generate a request for a burst transfer ([CHCTRLAn.TRIGACT=0x2](#)) or transaction transfer ([CHCTRLAn.TRIGACT=0x3](#)) instead of a block transfer ([CHCTRLAn.TRIGACT=0x0](#)).

The following figure shows an example where triggers are used with two linked block descriptors.

Figure 25-7. Trigger Action and Transfers



If the trigger source generates a transfer request for a channel during an ongoing transfer, the new transfer request will be kept pending (CHSTATUSn.PEND=1), and the new transfer can start after the ongoing one is done. Only one pending transfer can be kept per channel. If the trigger source generates more transfer requests while one is already pending, the additional ones will be lost. All channels pending status flags are also available in the Pending Channels register (PENDCH).

When the transfer starts, the corresponding Channel Busy status flag is set in Channel n Status register (CHSTATUSn.BUSY). When the trigger action is complete, the Channel Busy status flag is cleared. All channel busy status flags are also available in the Busy Channels register (BUSYCH) in DMAC.

### 25.5.2.7 Addressing

Each block transfer needs to have both a source address and a destination address defined. The source address is set by writing the Transfer Source Address (SRCADDR) register, the destination address is set by writing the Transfer Destination Address (DSTADDR) register.

The addressing of this DMAC module can be static or incremental, for either source or destination of a block transfer, or both.

Incrementation for the source address of a block transfer is enabled by writing the Source Address Incrementation Enable bit in the Block Transfer Control register (BTCTRL.SRCINC=1). The step size of the incrementation is configurable and can be chosen by writing the Step Selection bit in



the Block Transfer Control register (**BTCTRL**.STEPSEL=1) and writing the desired step size in the Address Increment Step Size bit group in the Block Transfer Control register (**BTCTRL**.STEPSIZE). If **BTCTRL**.STEPSEL=0, the step size for the source incrementation will be the size of one beat.

When source address incrementation is configured (**BTCTRL**.SRCINC=1), **SRCADDR** is calculated as follows:

If **BTCTRL**.STEPSEL=1:

$$\text{SRCADDR} = \text{SRCADDR}_{\text{START}} + \text{BTCNT} \cdot (\text{BEATSIZE} + 1) \cdot 2^{\text{STEPSIZE}}$$

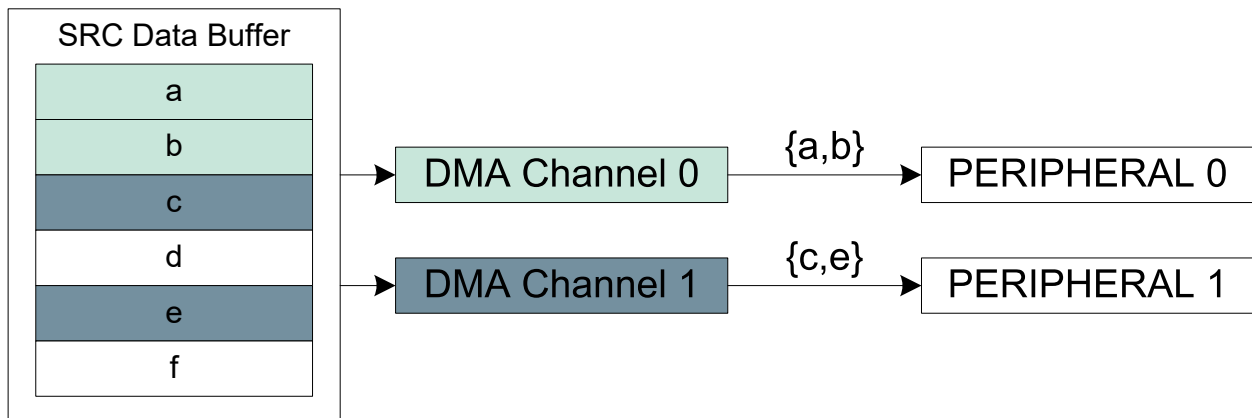
If **BTCTRL**.STEPSEL=0:

$$\text{SRCADDR} = \text{SRCADDR}_{\text{START}} + \text{BTCNT} \cdot (\text{BEATSIZE} + 1)$$

- **SRCADDR**<sub>START</sub> is the source address of the first beat transfer in the block transfer
- **BTCNT** is the initial number of beats remaining in the block transfer
- **BEATSIZE** is the configured number of bytes in a beat
- **STEPSIZE** is the configured number of beats for each incrementation

The following figure shows an example where DMA channel 0 is configured to increment the source address by one beat after each beat transfer (**BTCTRL**.SRCINC=1), and DMA channel 1 is configured to increment the source address by two beats (**BTCTRL**.SRCINC=1, **BTCTRL**.STEPSEL=1, and **BTCTRL**.STEPSIZE=0x1). As the destination address for both channels are peripherals, destination incrementation is disabled (**BTCTRL**.DSTINC=0).

**Figure 25-8.** Source Address Increment



Incrementation for the destination address of a block transfer is enabled by setting the Destination Address Incrementation Enable bit in the Block Transfer Control register (**BTCTRL**.DSTINC=1). The step size of the incrementation is configurable by clearing **BTCTRL**.STEPSEL=0 and writing **BTCTRL**.STEPSIZE to the desired step size. If **BTCTRL**.STEPSEL=1, the step size for the destination incrementation will be the size of one beat.

When the destination address incrementation is configured (**BTCTRL**.DSTINC=1), **DSTADDR** must be set and calculated as follows:

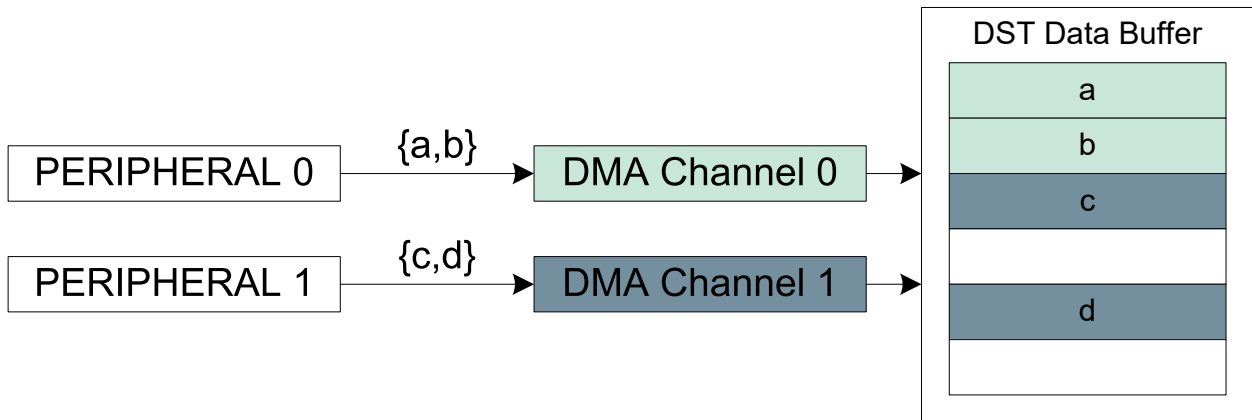
$\text{DSTADDR} = \text{DSTADDR}_{\text{START}} + \text{BTCNT} \cdot (\text{BEATSIZE} + 1) \cdot 2^{\text{STEPSIZE}}$	where <b>BTCTRL</b> .STEPSEL is zero
$\text{DSTADDR} = \text{DSTADDR}_{\text{START}} + \text{BTCNT} \cdot (\text{BEATSIZE} + 1)$	where <b>BTCTRL</b> .STEPSEL is one

- **DSTADDR**<sub>START</sub> is the destination address of the first beat transfer in the block transfer
- **BTCNT** is the initial number of beats remaining in the block transfer

- BEATSIZE is the configured number of bytes in a beat
- STEPSIZE is the configured number of beats for each incrementation

The following figure shows an example where DMA channel 0 is configured to increment destination address by one beat (`BTCTRL.DSTINC=1`) and DMA channel 1 is configured to increment destination address by two beats (`BTCTRL.DSTINC=1`, `BTCTRL.STEPSEL=0`, and `BTCTRL.STEPSIZE=0x1`). As the source address for both channels are peripherals, source incrementation is disabled (`BTCTRL.SRCINC=0`).

Figure 25-9. Destination Address Increment



### 25.5.2.8 Internal FIFO

To improve the bandwidth, the DMAC can support FIFO operation. When single-beat burst configuration is selected (`CHCTRLx.BURSTLEN = SINGLE`), the channel waits until the FIFO can transmit or accept a single beat transfer before it requests a bus access to write to the destination address. In all other cases, the channel waits until the FIFO threshold is reached before it requests a bus access to write to the destination address. The threshold is configurable and can be set by writing the `THRESHOLD` bits in the Channel x Control A register.

If the DMAC completes the read operations before the threshold is reached, the write to the destination is automatically enabled. If the FIFO is empty and the read from source is ongoing, the DMA will wait again until the FIFO threshold is reached before it requests a bus access to write the destination.

### 25.5.2.9 Error Handling

If a bus error is received from an AHB Client during a DMA data transfer, the corresponding active channel is disabled and the corresponding Channel Transfer Error Interrupt flag in the Channel Interrupt Status and Clear register (`CHINTFLAG.TERR`) is set. If enabled, the optional transfer error interrupt is generated. The transfer counter will not be decremented and its current value is written-back in the write-back memory section before the channel is disabled.

When the DMAC fetches an invalid descriptor (`BTCTRL.VALID=0`) or when the channel is resumed and the DMA fetches the next descriptor with null address (`DESCADDR=0x00000000`), the corresponding channel operation is suspended, the Channel Suspend Interrupt Flag in the Channel Interrupt Flag Status and Clear register (`CHINTFLAG.SUSP`) is set, and the Channel Fetch Error bit in the Channel Status register (`CHSTATUS.FERR`) is set. If enabled, the optional suspend interrupt is generated.

## 25.5.3 Additional Features

### 25.5.3.1 Linked Descriptors

A transaction can consist of either a single block transfer or of several block transfers. When a transaction consists of several block transfers it is done with the help of linked descriptors.

Figure 25-3 illustrates how linked descriptors work. When the first block transfer is completed on DMA channel 0, the DMAC fetches the next transfer descriptor, which is pointed to by the value stored in the Next Descriptor Address (**DESCADDR**) register of the first transfer descriptor. Fetching the next transfer descriptor (**DESCADDR**) is continued until the last transfer descriptor. When the block transfer for the last transfer descriptor is executed and **DESCADDR=0x00000000**, the transaction is terminated. For further details on how the next descriptor is fetched from SRAM, refer to section 25.5.2.5. [Data Transmission](#).

#### 25.5.3.1.1 Adding Descriptor to the End of a List

To add a new descriptor at the end of the descriptor list, create the descriptor in SRAM, with **DESCADDR=0x00000000** indicating that it is the new last descriptor in the list, and modify the **DESCADDR** value of the current last descriptor to the address of the newly created descriptor.

#### 25.5.3.1.2 Modifying a Descriptor in a List

In order to add descriptors to a linked list, the following actions must be performed:

1. Enable the Suspend interrupt for the DMA channel.
2. Enable the DMA channel.
3. Reserve memory space in SRAM to configure a new descriptor.
4. Configure the new descriptor:
  - Set the next descriptor address (**DESCADDR**)
  - Set the destination address (**DSTADDR**)
  - Set the source address (**SRCADDR**)
  - Configure the block transfer control (**BTCTRL**) including
    - Optionally enable the suspend block action
    - Set the descriptor VALID bit
5. Clear the VALID bit for the existing list and for the descriptor which has to be updated.
6. Read **DESCADDR** from the write-back memory.
  - If the DMA has not already fetched the descriptor that requires changes (i.e., **DESCADDR** is wrong):
    - Update the **DESCADDR** location of the descriptor from the list
    - Optionally clear the suspend block action
    - Set the descriptor VALID bit to '1'
    - Optionally enable the Resume Software command
  - If the DMA is executing the same descriptor as the one that requires changes:
    - Set the Channel Suspend Software command and wait for the suspend interrupt
    - Update the next descriptor address (**DESCRADDR**) in the write-back memory
    - Clear the interrupt sources and set the Resume Software command
    - Update the **DESCADDR** location of the descriptor from the list
    - Optionally clear the suspend block action
    - Set the descriptor VALID bit to '1'
7. Go to step 4 if needed.

#### 25.5.3.1.3 Adding a Descriptor Between Existing Descriptors

To insert a new descriptor 'C' between two existing descriptors ('A' and 'B'), the descriptor currently executed by the DMA must be identified.

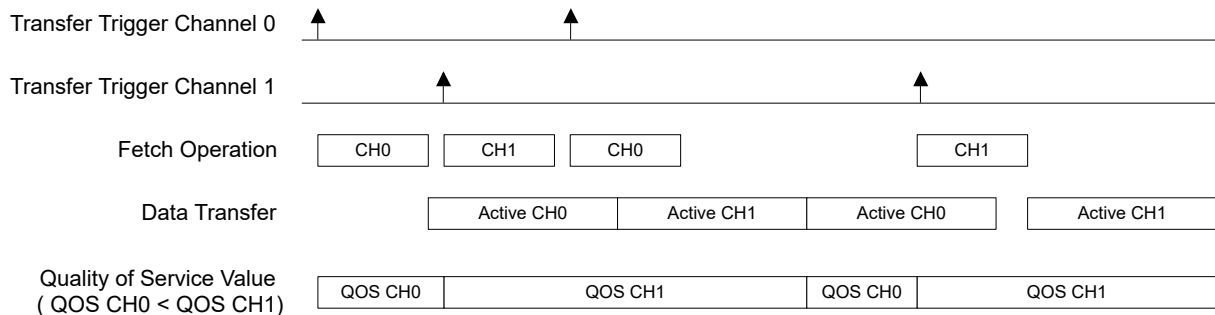
1. If DMA is executing descriptor B, descriptor C cannot be inserted.

2. If DMA has not started to execute descriptor A, follow the steps:
  - a. Set the descriptor A VALID bit to '0'.
  - b. Set the **DESCADDR** value of descriptor A to point to descriptor C instead of descriptor B.
  - c. Set the **DESCADDR** value of descriptor C to point to descriptor B.
  - d. Set the descriptor A VALID bit to '1'.
3. If DMA is executing descriptor A:
  - a. Apply the software suspend command to the channel and
  - b. Perform steps 2.1 through 2.4.
  - c. Apply the software resume command to the channel.

### 25.5.3.2 Transfer Quality of Service

Each priority level group has dedicated quality of service settings. The setting can be written in the corresponding Quality of Service bit group in the Priority Control x register (PRICTRL0.QOSn).

**Figure 25-10.** Quality of Service



When a channel is stored in the Pre-Fetch or Active Channel, the corresponding PRICTRLx.QOS bits value is stored in the respective channel. As shown in Quality of Service, the DMAC will select the highest QOS value between Active and Pre-Fetch channels. This value will apply to all DMAC buses.

### 25.5.3.3 Channel Suspend

The channel operation can be suspended at any time by software by writing a '1' to the Suspend command in the Command bit field of Channel Control B register (CHCTRLB.CMD). After the ongoing burst transfer is completed, the channel operation is suspended and the suspend command is automatically cleared.

When suspended, the Channel Suspend Interrupt flag in the Channel Interrupt Status and Clear register is set (CHINTFLAG.SUSP=1) and the optional suspend interrupt is generated.

By configuring the block action to suspend by writing Block Action bit group in the Block Transfer Control register (BTCTRL.BLOCKACT is 0x2 or 0x3), the DMA channel will be suspended after it has completed a block transfer. The DMA channel will be kept enabled and will be able to receive transfer triggers, but it will be removed from the arbitration scheme.

If an invalid transfer descriptor (BTCTRL.VALID=0) is fetched from SRAM, the DMA channel will be suspended, and the Channel Fetch Error bit in the Channel Status register (CHASTATUS.FERR) will be set.

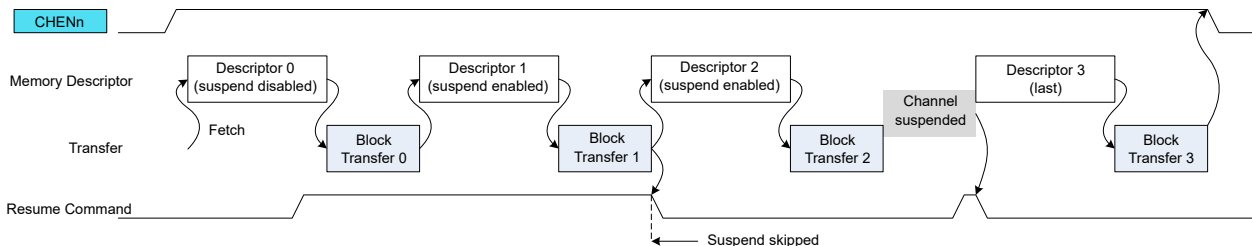
**Note:** Only enabled DMA channels can be suspended. If a channel is disabled when it is attempted to be suspended, the internal suspend command will be ignored.

For more details on transfer descriptors, refer to section [25.5.2.3. Transfer Descriptors](#).

### 25.5.3.4 Channel Resume and Next Suspend Skip

A channel operation can be resumed by software by setting the Resume command in the Command bit field of the Channel Control B register (CHCTRLB.CMD). If the channel is already suspended, the channel operation resumes from where it previously stopped when the Resume command is detected. When the Resume command is issued before the channel is suspended, the next suspend action is skipped and the channel continues the normal operation.

**Figure 25-11.** Channel Suspend/Resume Operation



### 25.5.3.5 Event Input Actions

The event input actions are available only on the least significant DMA channels. For details on channels with event input support, refer to the [Event System](#) documentation.

Before using event input actions, the event controller must be configured first according to the following table, and the Channel Event Input Enable bit in the Channel Event Control register (CHEVCTRL.EVIE) must be written to '1'. Refer also to [25.5.5. Events](#).

**Table 25-1.** Event Input Action

Action	CHEVCTRL.EVACT	CHCTRLA.TRIGSRC
None	NOACT	-
Normal Transfer	TRIG	DISABLE
Conditional Transfer on Strobe	TRIG	Any peripheral
Conditional Transfer	CTRIG	
Conditional Block Transfer	CBLOCK	
Channel Suspend	SUSPEND	
Channel Resume	RESUME	
Skip Next Block Suspend	SSKIP	
Increase priority	INCPRI	

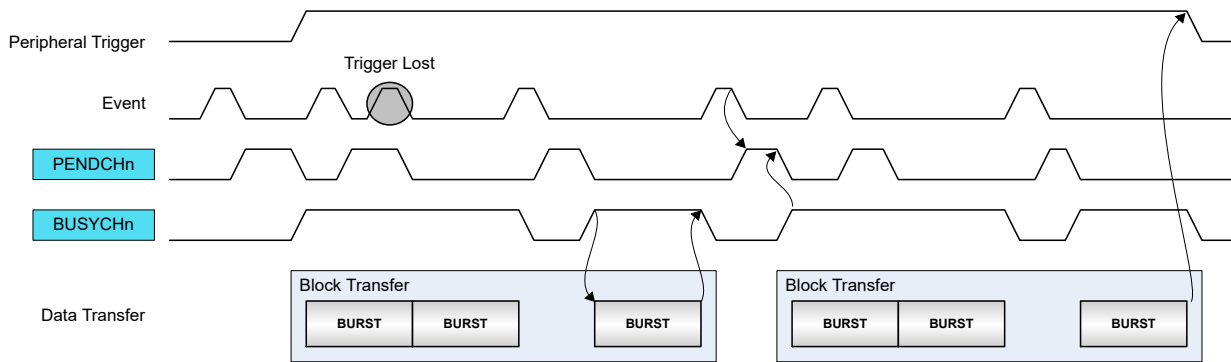
#### Normal Transfer

The event input is used to trigger a beat or burst transfer on peripherals.

The event is acknowledged as soon as the event is received. When received, both the Channel Pending status bit in the Channel Status register (CHSTATUS.PEND) and the corresponding Channel n bit in the Pending Channels register (PENDCH.PENDCHn) are set. If the event is received while the channel is pending, the event trigger is lost.

The figure below shows an example where beat transfers are enabled by internal events.

**Figure 25-12.** Burst Event Trigger Action



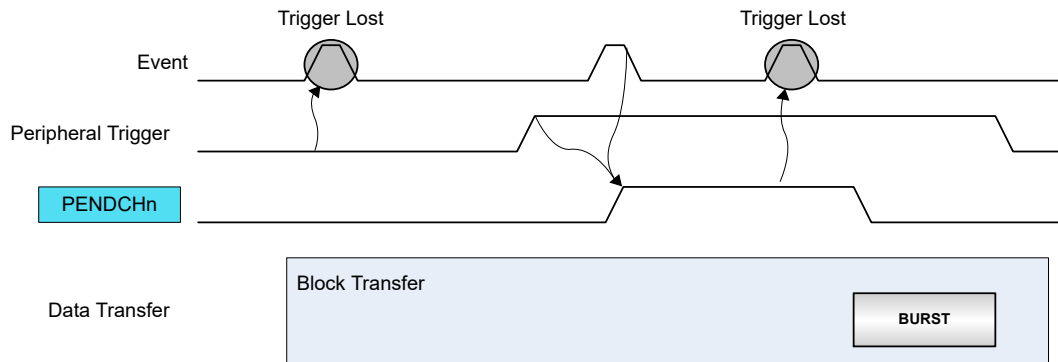
### Conditional Transfer on Strobe

The event input is used to trigger a transfer on peripherals with pending transfer requests. This event action is intended to be used with peripheral triggers, e.g., for timed communication protocols or periodic transfers between peripherals: only when the peripheral trigger coincides with the occurrence of a (possibly cyclic) event the transfer is issued.

The event is acknowledged as soon as the event is received. The peripheral trigger request is stored internally when the previous trigger action is completed (i.e., the channel is not pending) and when an active event is received. If the peripheral trigger is active, the DMA will wait for an event before the peripheral trigger is internally registered. When both event and peripheral transfer trigger are active, both CHSTATUS.PEND and PENDINGn.PENDINGn are set. A software trigger will now trigger a transfer.

The figure below shows an example where the peripheral beat transfer is started by a conditional strobe event action.

**Figure 25-13.** Periodic Event with Burst Peripheral Triggers



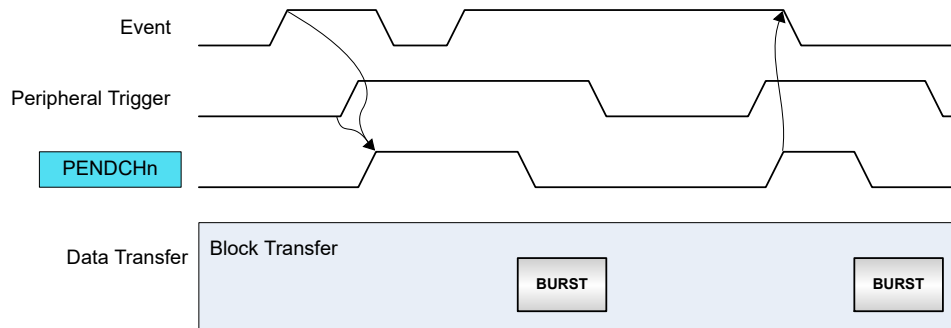
### Conditional Transfer

The event input is used to trigger a conditional transfer on peripherals with pending transfer requests. As example, this type of event can be used for peripheral-to-peripheral transfers, where one peripheral is the source of event and the second peripheral is the source of the trigger.

Each peripheral trigger is stored internally when the event is received. When the peripheral trigger is stored internally, the Channel Pending status bit is set (CHSTATUS.PEND), the respective Pending Channel n Bit in the Pending Channels register is set (PENDINGn.PENDINGn), and the event is acknowledged. A software trigger will now trigger a transfer.

The figure below shows an example where conditional event is enabled with peripheral beat trigger requests.

**Figure 25-14.** Conditional Event with Burst Peripheral Triggers



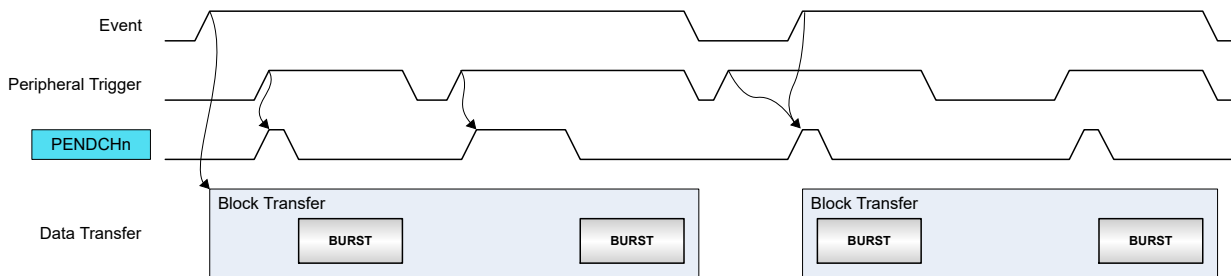
### Conditional Block Transfer

The event input is used to trigger a conditional block transfer on peripherals.

Before starting transfers within a block, an event must be received. When received, the event is acknowledged when the block transfer is completed. A software trigger will trigger a transfer.

The figure below shows an example where conditional event block transfer is started with peripheral beat trigger requests.

**Figure 25-15.** Conditional Block Transfer with Burst Peripheral Triggers



### Channel Suspend

The event input is used to suspend an ongoing channel operation. The event is acknowledged when the current AHB access is completed. For further details on Channel Suspend, refer to [25.5.3.3. Channel Suspend](#).

### Channel Resume

The event input is used to resume a suspended channel operation. The event is acknowledged as soon as the event is received and the Channel Suspend Interrupt Flag (CHINTFLAG.SUSP) is cleared. For further details refer to [25.5.3.3. Channel Suspend](#).

### Skip Next Block Suspend

This event can be used to skip the next block suspend action. If the channel is suspended before the event rises, the channel operation is resumed and the event is acknowledged. If the event rises before a suspend block action is detected, the event is kept until the next block suspend detection. When the block transfer is completed, the channel continues the operation (not suspended) and the event is acknowledged.

### Increase priority

This event can be used to increase a channel priority and to request higher quality of service (QOS), when critical transfers must be done. When the event is detected, the channel will have the highest

priority and the output Quality of Service value is internally forced to the maximum value. The event is acknowledged when the trigger action execution is completed. When acknowledged, the channel will recover its initial priority level and quality of service settings.

### 25.5.3.6 Event Output Selection

The event output selections are available only for channels supporting event outputs.

The Channel Event Output Enable can be set in the corresponding Channel n Event Control register (CHEVCTRL.EVOE). The Event Output Mode bits in Channel n Event Control register (CHEVCTRL.EVOMODE) selects the event type the channel should generate.

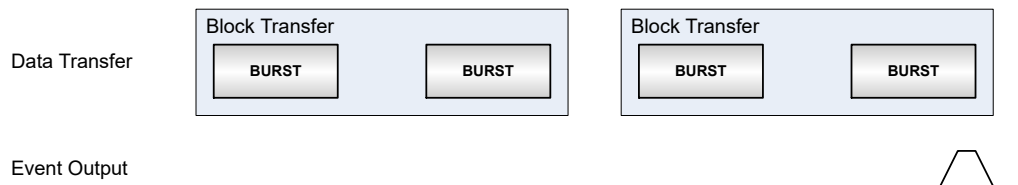
The transfer events (CHEVCTRL.EVOMODE = DEFAULT) are strobe events and their duration is one CLK\_DMACH\_AHB clock period. The transfer event type selection is available in each Descriptor Block Control location (BTCTRL.EVOSEL). Block or burst event output generation is supported.

The trigger action event (CHEVCTRL.EVOMODE = TRIGACT) is a level, active while the trigger action execution is not completed.

#### Block event output

When the block event output is selected, an event strobe is generated when the block transfer is completed. The pulse width of a block event output from a channel is one AHB clock cycle. It is also possible to use this event type to generate an event when the transaction is complete. For this type of application, the block event selection must be set in the last transfer descriptor only, as shown below.

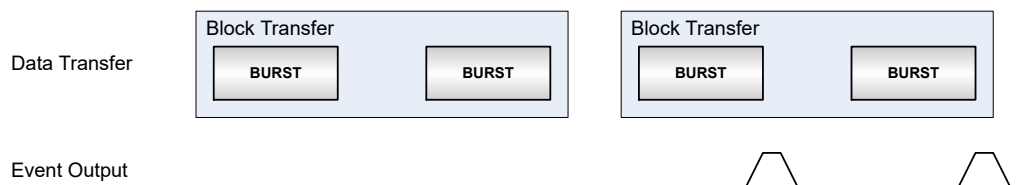
Figure 25-16. Block Event Output Generation



#### Burst event output

When the burst event output is selected, an event strobe is generated when each burst transfer within the corresponding block is completed. The pulse width of a burst event output from a channel is one AHB clock cycle. The figure below shows an example where the burst event output is set in the second descriptor of a linked list.

Figure 25-17. Burst Event Output Generation



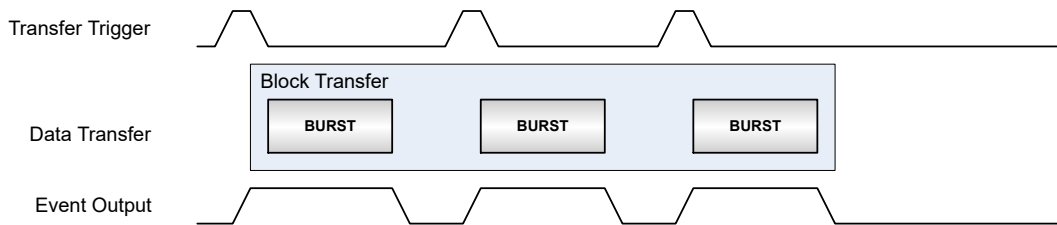
#### Trigger action event output

When the trigger action event output is selected, an event level is generated. Then event output is set when the transfer trigger occurred, and cleared when the corresponding trigger action is completed. The figure below shows an example for each trigger action type.

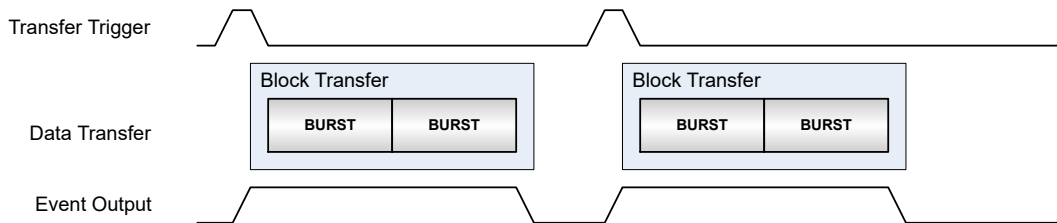


Figure 25-18. Trigger Action Event Output Generation

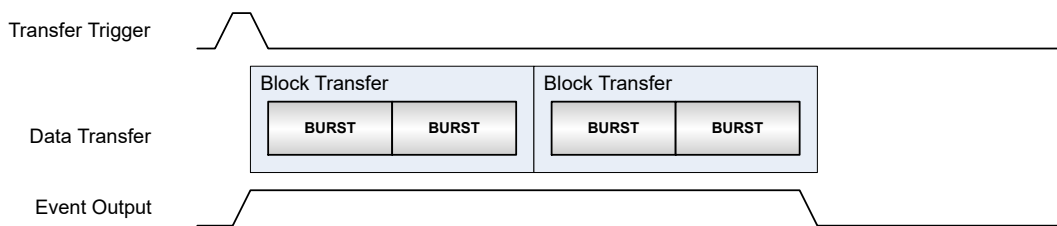
### Burst Trigger Action Event Output



### Block Trigger Action Event Output



### Transaction Trigger Action Event Output



#### 25.5.3.7 Aborting Transfers

Transfers on any channel can be aborted gracefully by software by disabling the corresponding DMA channel. It is also possible to abort all ongoing or pending transfers by disabling the DMAC.

When a DMA channel disable request or DMAC disable request is detected:

- Ongoing transfers of the active channel will be disabled when the ongoing beat transfer is completed and the write-back memory section is updated. This prevents transfer corruption before the channel is disabled.
- All other enabled channels will be disabled in the next clock cycle.

The corresponding Channel Enable bit in the Channel Control A register is cleared (CHCTRLA.ENABLE=0) when the channel is disabled.

The corresponding DMAC Enable bit in the Control register is cleared (CTRL.DMAENABLE=0) when the entire DMAC module is disabled.

#### 25.5.3.8 CRC Operation

A Cyclic Redundancy Check (CRC) is an error detection technique used to find errors in data. It is commonly used to determine whether the data during a transmission, or data present in data and program memories has been corrupted or not. A CRC takes a data stream or a block of data as input and generates a 16- or 32-bit output that can be appended to the data and used as a checksum.

When the data is received, the device or application repeats the calculation using the DSU's CRC engine. If the new CRC result does not match the one calculated earlier, the block contains a data error. The application will then detect this and may take a corrective action, such as requesting the data to be sent again or simply not using the incorrect data.

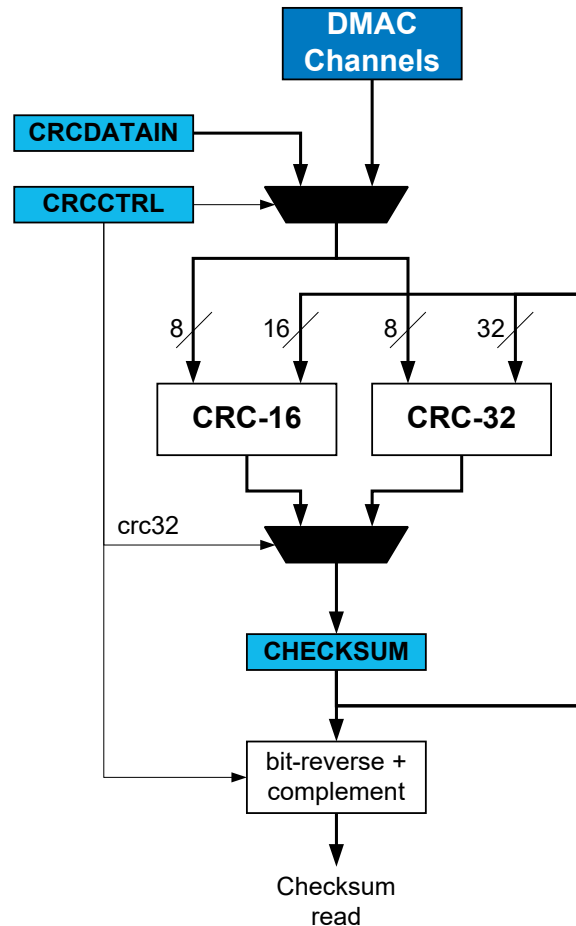
The CRC engine in DMAC supports two commonly used CRC polynomials: CRC-16 (CRC-CCITT) and CRC-32 (IEEE 802.3). Typically, applying CRC-n (CRC-16 or CRC-32) to a data block of arbitrary length will detect any single alteration that is  $\leq n$  bits in length, and will detect the fraction  $1-2^{-n}$  of all longer error bursts.

- CRC-16:
  - Polynomial:  $x^{16} + x^{12} + x^5 + 1$
  - Hex value: 0x1021
- CRC-32:
  - Polynomial:  $x^{32} + x^{26} + x^{23} + x^{22} + x^{16} + x^{12} + x^{11} + x^{10} + x^8 + x^7 + x^5 + x^4 + x^2 + x + 1$
  - Hex value: 0x04C11DB7

The data source for the CRC engine can either be one of the DMA channels or the APB bus interface, and must be selected by writing to the CRC Input Source bits in the CRC Control register (CRCCTRL.CRCSRC). The CRC engine then takes data input from the selected source and generates a checksum based on these data. The checksum is available in the CRC Checksum register (CRCCHKSUM). When CRC-32 polynomial is used, the final checksum read is bit reversed and complemented, as shown in Figure 22-19. *CRC Generator Block Diagram*.

The CRC polynomial is selected by writing to the CRC Polynomial Type bit in the CRC Control register (CRCCTRL.CRCPOLY), the default is CRC-16. The CRC engine operates on byte only. When the DMA is used as data source for the CRC engine, the DMA channel beat size setting will be used. When used with APB bus interface, the application must select the CRC Beat Size bit field of CRC Control register (CRCCTRL.CRCBEATSIZE). 8-, 16-, or 32-bit bus transfer access type is supported. The corresponding number of bytes will be written in the CRCDATAIN register and the CRC engine will operate on the input data in a byte by byte manner.

Figure 25-19. CRC Generator Block Diagram



**CRC on DMA data** CRC-16 or CRC-32 calculations can be performed on data passing through any DMA channel. Once a DMA channel is selected as the source, the CRC engine will continuously generate the CRC on the data passing through the DMA channel. The checksum is available for readout once the DMA transaction is completed or aborted. A CRC can also be generated on SRAM, Flash, or I/O memory by passing these data through a DMA channel. If the latter is done, the destination register for the DMA data can be the data input (CRCDATAIN) register in the CRC engine.

**CRC using the I/O interface** Before using the CRC engine with the I/O interface, the application must set the CRC Beat Size bits in the CRC Control register (CRCCTRL.CRCBEATSIZE). 8/16/32-bit bus transfer type can be selected.

CRC can be performed on any data by loading them into the CRC engine using the CPU and writing the data to the CRCDATAIN register. Using this method, an arbitrary number of bytes can be written to the register by the CPU, and CRC is done continuously for each byte. This means if a 32-bit data is written to the CRCDATAIN register the CRC engine takes four cycles to calculate the CRC. The CRC complete is signaled by a set CRCBUSY bit in the CRCSTATUS register. New data can be written only when CRCBUSY flag is not set.

### 25.5.3.9 Memory CRC Generation

When enabled, it is possible to automatically calculate a memory block checksum. When the channel is enabled and the descriptor is fetched, the CRC Checksum register (CRCCHKSUM) is reloaded with the initial checksum value (CHKINIT) stored in the Block Transfer Destination Address register (DSTADDR). The DMA read and calculate the checksum over the data from the source address. When the checksum calculation is completed, the CRC value is stored in the CRC Checksum register (CRCCHKSUM), the Transfer Complete interrupt flag is set (CHINTFLAGn.TCMPL) and optional interrupt is generated.

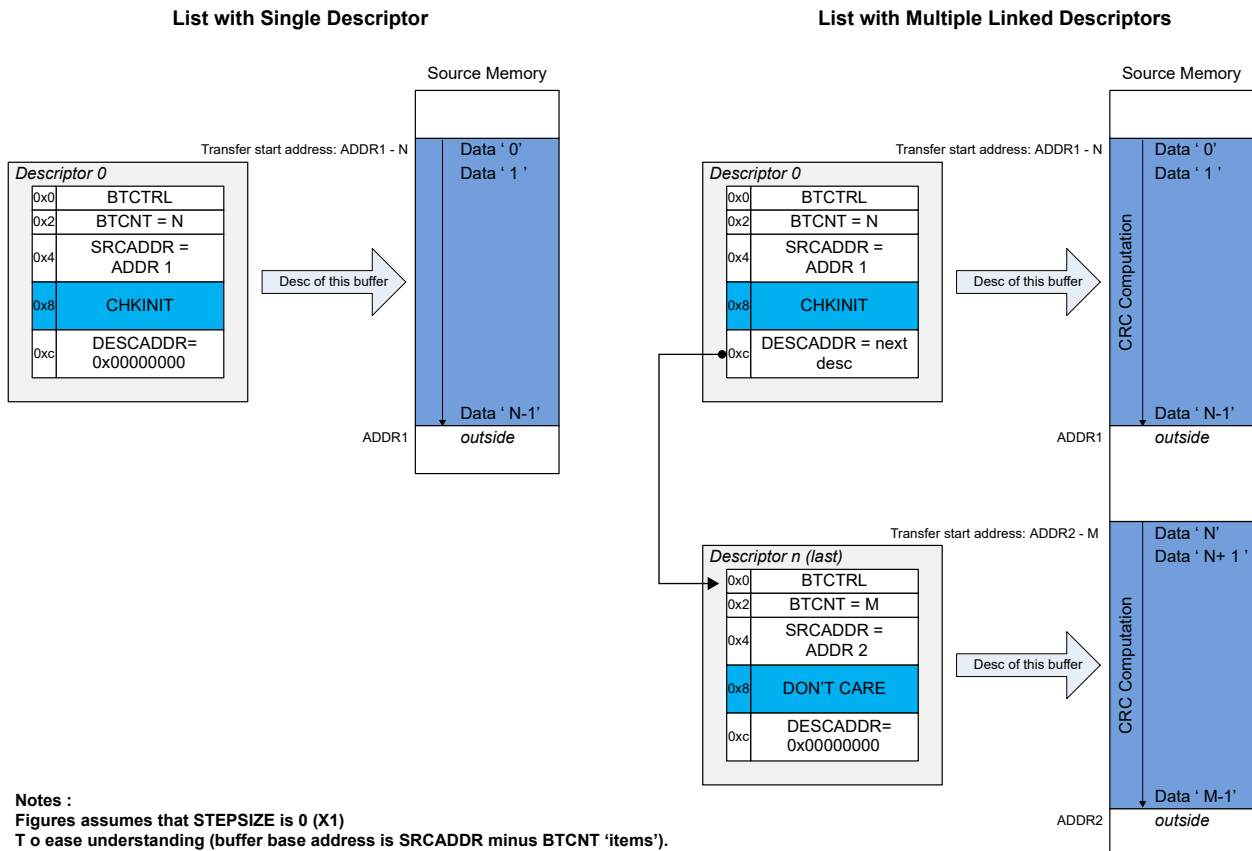
If linked descriptor is in the list (DESCADDR !=0), the DMA will fetch the next descriptor and CRC calculation continues as described above. When the last list descriptor is executed, the channel is automatically disabled.

In order to enable the memory CRC generation, the following actions must be performed:

1. The CRC module must be set to be used with a DMA channel (CRCCTRL.CRCSRC)
2. Reserve memory space addresses to configure a descriptor or a list of descriptors
3. Configure each descriptor:
  - Set the next descriptor address (DESCADDR)
  - Set the destination address with the initial checksum value (DSTADDR = CHKINIT) in the first descriptor in a list
  - Set the transfer source address (SRCADDR)
  - Set the block transfer count (BTCNT)
  - Set the memory CRC generation operation mode (CRCCTRL.CRCMODE = CRCGEN)
  - Enable optional interrupts
4. Enable the corresponding DMA channel (CHCTRLn.ENABLE)

The figure below shows the CRC computation slots and descriptor configuration when single or linked-descriptors transfers are enabled.

**Figure 25-20. CRC Computation with Single Linked Transfers**



### 25.5.3.10 Memory CRC Monitor

When enabled, it is possible to continuously check a memory block data integrity by calculating and checking the CRC checksum. The expected CRC checksum value must be located in the last memory block location, as shown in the table below:

CRCCTRL.CRCPOLY	CRCCTRL.CRCBEATSIZE	Last Memory Block Byte Locations Value (MSB Byte First)	CHECKSUM Result
CRC-16	Byte	Expected CRC[7:0]	0x00000000
	Half-word	Expected CRC[15:8]	
	Word	0x00 0x00 Expected CRC[7:0] Expected CRC[15:8]	
CRC-32	Byte	Expected CRC[31:24]	CRC Magic Number (0x2144DF1C)
	Half-word	Expected CRC[23:16]	
	Word	Expected CRC[15:8] Expected CRC[7:0]	

When the channel is enabled and the descriptor is fetched, the CRC Checksum register (CRCCHKSUM) is reloaded with the initial checksum value (CHKINIT), stored in the DSTADDR location of the first descriptor. The DMA read and calculate the checksum over the entire data from the source address. When the checksum calculation is completed the DMA read the last beat from the memory, the calculated CRC value from the CRC Checksum register is compared to zero or CRC magic number, depending on CRC polynomial selection.

If the CHECKSUM does not match the comparison value the DMA channel is disabled, and both the CRC Error bit in the Channel n Status register (CHSTATUSn.CRCERR) and Transfer Error interrupt flag (CHINTFLAGn.TERR) are set. If enabled, the Transfer Error interrupt is generated.

If the calculated checksum value matches the compare value, the Transfer Complete interrupt flag (CHINTFLAGn.TCMLP) is set, optional interrupt is generated and the DMA will perform the following actions, depending on the descriptor list settings:

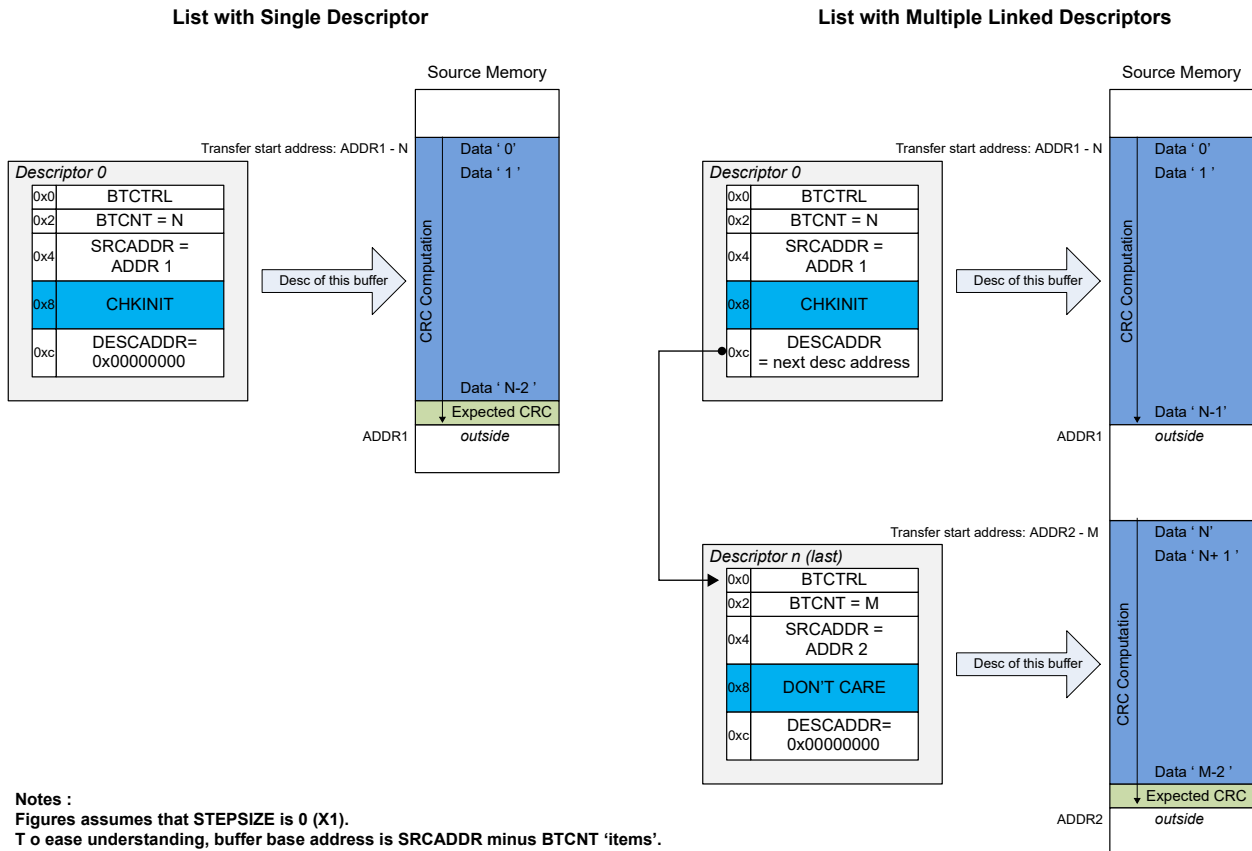
- If the list has only one descriptor, the DMA will re-fetch the descriptor
- If the current descriptor is the last descriptor from the list, the DMA will fetch the first descriptor from the list

When the fetch is completed, the DMA restarts the operations described above when new triggers are detected.

In order to enable the memory CRC monitor, the following actions must be performed:

1. The CRC module must be set to be used with a DMA channel (CRCCTRL.CRCSRC)
2. Reserve memory space addresses to configure a descriptor or a list of descriptors
3. Configure each descriptor
  - Set the next descriptor address (DESCADDR)
  - In the first list descriptor, set the destination address with the initial checksum value (DSTADDR = CHKINIT)
  - Set the transfer source address (SRCADDR)
  - Set the block transfer count (BTCNT)
  - Set the memory CRC monitor operation mode (CRCCTRL.CRCMODE = CRCMON)
  - Enable optional interrupts
4. Enable the corresponding DMA channel (CHCTRLAn.ENABLE)

**Figure 25-21.** CRC Computation and Check with Single or Linked Transfers



## 25.5.4 Interrupts

The DMAC channels have the following interrupt sources:

- Transfer Complete (TCMPL): Indicates that a block transfer is completed on the corresponding channel. Refer to 25.5.2.5. [Data Transmission](#) for details.
- Transfer Error (TERR): Indicates that a bus error has occurred during a burst transfer, or that an invalid descriptor has been fetched. Refer to 25.5.2.9. [Error Handling](#) for details.
- Channel Suspend (SUSP): Indicates that the corresponding channel has been suspended. Refer to 25.5.3.3. [Channel Suspend](#) and 25.5.2.5. [Data Transmission](#) for details.

Each interrupt source has an Interrupt flag associated with it. The Interrupt flag in the Channel Interrupt Flag Status and Clear (CHINTFLAG) register is set when the Interrupt condition occurs. Each interrupt can be individually enabled by setting the corresponding bit in the Channel Interrupt Enable Set register (CHINTENSET=1), and disabled by setting the corresponding bit in the Channel Interrupt Enable Clear register (CHINTENCLR=1). The status of enabled interrupts can be read from either INTENSET or INTENCLR.

An interrupt request is generated when the Interrupt flag is set and the corresponding interrupt is enabled. The interrupt request remains active until the Interrupt flag is cleared, the interrupt is disabled, the DMAC is reset or the corresponding DMA channel is reset. See CHINTFLAG for details on how to clear Interrupt flags. All interrupt requests are ORed together on system level to generate one combined interrupt request to the NVIC.

The user must read the Channel Interrupt Status (INTSTATUS) register to identify the channels with pending interrupts and must read the Channel Interrupt Flag Status and Clear (CHINTFLAG) register to determine which Interrupt condition is present for the corresponding channel. It is also possible

to read the Interrupt Pending register (INTPEND), which provides the lowest channel number with pending interrupt and the respective Interrupt flags.

**Note:** Interrupts must be globally enabled for interrupt requests to be generated.

### 25.5.5 Events

The DMAC can generate the following output events:

- Channel (CH): Generated when a block transfer for a given channel has been completed, or when a beat transfer within a block transfer for a given channel has been completed. Refer to [Event Output Selection](#) for details.

Setting the Channel Event Output Enable bit (CHEVCTRLx.EVOE = 1) enables the corresponding output event configured in the Event Output Selection bit group in the Block Transfer Control register (BTCTRL.EVOSEL). Clearing CHEVCTRLx.EVOE = 0 disables the corresponding output event.

The DMAC can take the following actions on an input event:

- Transfer and Periodic Transfer Trigger (TRIG): normal transfer or periodic transfers on peripherals are enabled
- Conditional Transfer Trigger (CTRIG): conditional transfers on peripherals are enabled
- Conditional Block Transfer Trigger (CBLOCK): conditional block transfers on peripherals are enabled
- Channel Suspend Operation (SUSPEND): suspend a channel operation
- Channel Resume Operation (RESUME): resume a suspended channel operation
- Skip Next Block Suspend Action (SSKIP): skip the next block suspend transfer condition
- Increase Priority (INCPRI): increase channel priority

Setting the Channel Event Input Enable bit (CHEVCTRLx.EVIE = 1) enables the corresponding action on input event. Clearing this bit disables the corresponding action on input event. Note that several actions can be enabled for incoming events. If several events are connected to the peripheral, any enabled action will be taken for any of the incoming events. For further details on event input actions, refer to [Event Input Actions](#).

**Note:** Event input and outputs are not available for every channel. Refer to the Features section for more information.

### 25.5.6 Sleep Mode Operation

The DMAC will continue to operate in IDLE 0 sleep mode. It does not perform transfers in IDLE 1 and IDLE 2 sleep modes, since the AHB clocks are stopped. In Standby mode, the DMAC will be internally disabled, but maintains its current configuration.

Each DMA channel can be configured to operate in any sleep mode. To be able to run in standby, the RUNSTDBY bit in Channel Control A register (CHCTRLA.RUNSTDBY) must be written to '1'. The DMAC can wake up the device using interrupts from any sleep mode or perform actions through the Event System.

For channels with CHCTRLA.RUNSTDBY = 0, it is up to software to stop DMA transfers on these channels and wait for completion before going to Standby mode using the following sequence:

1. Suspend the DMAC channels for which CHCTRLA.RUNSTDBY = 0.
2. Check the SYNCBUSY bits of registers accessed by the DMAC channels being suspended.
3. Go to sleep.
4. When the device wakes up, resume the suspended channels.

**Note:** In Standby mode, the DMAC can only access RAM when it is not back biased (PM.STDBYCFG.BBIASxx = 0x0)

**Note:** In Standby mode, the DMAC can access the LP SRAM only when the power domain PD1 is not in retention and PM.STDBYCFG.BBIASLP = 0x0. The DMAC can access the SRAM in Standby mode only when the power domain PD2 is not in retention and PM.STDBYCFG.BBIASHS = 0x0.



## 25.6 Register Summary

Offset	Name	Bit Pos.	7	6	5	4	3	2	1	0
0x00	CTRL	7:0							DMAENABLE	SWRST
		15:8					LVLEN3	LVLEN2	LVLEN1	LVLENO
0x02	CRCCTRL	7:0					CRCPOLY[1:0]		CRCBEATSIZE[1:0]	
		15:8	CRCMODE[1:0]			CRCSRC[5:0]				
0x04	CRCDATAIN	7:0	CRCDATAIN[7:0]							
		15:8	CRCDATAIN[15:8]							
		23:16	CRCDATAIN[23:16]							
		31:24	CRCDATAIN[31:24]							
0x08	CRCCHKSUM	7:0	CRCCHKSUM[7:0]							
		15:8	CRCCHKSUM[15:8]							
		23:16	CRCCHKSUM[23:16]							
		31:24	CRCCHKSUM[31:24]							
0x0C	CRCSTATUS	7:0						CRCERR	CRCZERO	CRCBUSY
0x0D	DBGCTRL	7:0								DBGRUN
0x0E ... 0x0F	Reserved									
0x10	SWTRIGCTRL	7:0	SWTRIG[7:0]							
		15:8	SWTRIG[15:8]							
		23:16	SWTRIG[23:16]							
		31:24	SWTRIG[31:24]							
0x14	PRICTRL0	7:0	RRLVLENO	QOS0[1:0]			LVLPRIO[4:0]			
		15:8	RRLVLEN1	QOS1[1:0]			LVLPRIO[4:0]			
		23:16	RRLVLEN2	QOS2[1:0]			LVLPRIO[4:0]			
		31:24	RRLVLEN3	QOS3[1:0]			LVLPRIO[4:0]			
0x18 ... 0x1F	Reserved									
0x20	INTPEND	7:0				ID[4:0]				
		15:8	PEND	BUSY	FERR	CRCERR		SUSP	TCMPL	TERR
0x22 ... 0x23	Reserved									
0x24	INTSTATUS	7:0	CHINT7	CHINT6	CHINT5	CHINT4	CHINT3	CHINT2	CHINT1	CHINT0
		15:8	CHINT15	CHINT14	CHINT13	CHINT12	CHINT11	CHINT10	CHINT9	CHINT8
		23:16	CHINT23	CHINT22	CHINT21	CHINT20	CHINT19	CHINT18	CHINT17	CHINT16
		31:24	CHINT31	CHINT30	CHINT29	CHINT28	CHINT27	CHINT26	CHINT25	CHINT24
0x28	BUSYCH	7:0	BUSYCH7	BUSYCH6	BUSYCH5	BUSYCH4	BUSYCH3	BUSYCH2	BUSYCH1	BUSYCH0
		15:8	BUSYCH15	BUSYCH14	BUSYCH13	BUSYCH12	BUSYCH11	BUSYCH10	BUSYCH9	BUSYCH8
		23:16	BUSYCH23	BUSYCH22	BUSYCH21	BUSYCH20	BUSYCH19	BUSYCH18	BUSYCH17	BUSYCH16
		31:24	BUSYCH31	BUSYCH30	BUSYCH29	BUSYCH28	BUSYCH27	BUSYCH26	BUSYCH25	BUSYCH24
0x2C	PENDCH	7:0	PENDCH7	PENDCH6	PENDCH5	PENDCH4	PENDCH3	PENDCH2	PENDCH1	PENDCH0
		15:8	PENDCH15	PENDCH14	PENDCH13	PENDCH12	PENDCH11	PENDCH10	PENDCH9	PENDCH8
		23:16	PENDCH23	PENDCH22	PENDCH21	PENDCH20	PENDCH19	PENDCH18	PENDCH17	PENDCH16
		31:24	PENDCH31	PENDCH30	PENDCH29	PENDCH28	PENDCH27	PENDCH26	PENDCH25	PENDCH24
0x30	ACTIVE	7:0					LVLEX3	LVLEX2	LVLEX1	LVLEX0
		15:8	ABUSY				ID[4:0]			
		23:16	BTCNT[7:0]							
		31:24	BTCNT[15:8]							
0x34	BASEADDR	7:0	BASEADDR[7:0]							
		15:8	BASEADDR[15:8]							
		23:16	BASEADDR[23:16]							
		31:24	BASEADDR[31:24]							
0x38	WRBADDR	7:0	WRBADDR[7:0]							
		15:8	WRBADDR[15:8]							
		23:16	WRBADDR[23:16]							
		31:24	WRBADDR[31:24]							

.....continued

Offset	Name	Bit Pos.	7	6	5	4	3	2	1	0
0x3C ... 0x3F	Reserved									
0x40	CHCTRLA0	7:0		RUNSTDBY					ENABLE	SWRST
		15:8					TRIGSRC[6:0]			
		23:16				TRIGACT[1:0]				
		31:24				THRESHOLD[1:0]		BURSTLEN[3:0]		
0x44	CHCTRLB0	7:0							CMD[1:0]	
0x45	CHPRILVL0	7:0							PRILVL[1:0]	
0x46	CHEVCTRL0	7:0	EVOE	EVIE	EVOMODE[1:0]				EVACT[2:0]	
0x47 ... 0x4B	Reserved									
0x4C	CHINTENCLR0	7:0						SUSP	TCMPL	TERR
0x4D	CHINTENSET0	7:0						SUSP	TCMPL	TERR
0x4E	CHINTFLAG0	7:0						SUSP	TCMPL	TERR
0x4F	CHSTATUS0	7:0					CRCERR	FERR	BUSY	PEND
0x50	CHCTRLA1	7:0		RUNSTDBY					ENABLE	SWRST
		15:8					TRIGSRC[6:0]			
		23:16				TRIGACT[1:0]				
		31:24				THRESHOLD[1:0]		BURSTLEN[3:0]		
0x54	CHCTRLB1	7:0							CMD[1:0]	
0x55	CHPRILVL1	7:0							PRILVL[1:0]	
0x56	CHEVCTRL1	7:0	EVOE	EVIE	EVOMODE[1:0]				EVACT[2:0]	
0x57 ... 0x5B	Reserved									
0x5C	CHINTENCLR1	7:0						SUSP	TCMPL	TERR
0x5D	CHINTENSET1	7:0						SUSP	TCMPL	TERR
0x5E	CHINTFLAG1	7:0						SUSP	TCMPL	TERR
0x5F	CHSTATUS1	7:0					CRCERR	FERR	BUSY	PEND
0x60	CHCTRLA2	7:0		RUNSTDBY					ENABLE	SWRST
		15:8					TRIGSRC[6:0]			
		23:16				TRIGACT[1:0]				
		31:24				THRESHOLD[1:0]		BURSTLEN[3:0]		
0x64	CHCTRLB2	7:0							CMD[1:0]	
0x65	CHPRILVL2	7:0							PRILVL[1:0]	
0x66	CHEVCTRL2	7:0	EVOE	EVIE	EVOMODE[1:0]				EVACT[2:0]	
0x67 ... 0x6B	Reserved									
0x6C	CHINTENCLR2	7:0						SUSP	TCMPL	TERR
0x6D	CHINTENSET2	7:0						SUSP	TCMPL	TERR
0x6E	CHINTFLAG2	7:0						SUSP	TCMPL	TERR
0x6F	CHSTATUS2	7:0					CRCERR	FERR	BUSY	PEND
0x70	CHCTRLA3	7:0		RUNSTDBY					ENABLE	SWRST
		15:8					TRIGSRC[6:0]			
		23:16				TRIGACT[1:0]				
		31:24				THRESHOLD[1:0]		BURSTLEN[3:0]		
0x74	CHCTRLB3	7:0							CMD[1:0]	
0x75	CHPRILVL3	7:0							PRILVL[1:0]	
0x76	CHEVCTRL3	7:0	EVOE	EVIE	EVOMODE[1:0]				EVACT[2:0]	
0x77 ... 0x7B	Reserved									
0x7C	CHINTENCLR3	7:0						SUSP	TCMPL	TERR
0x7D	CHINTENSET3	7:0						SUSP	TCMPL	TERR
0x7E	CHINTFLAG3	7:0						SUSP	TCMPL	TERR
0x7F	CHSTATUS3	7:0					CRCERR	FERR	BUSY	PEND

.....continued

Offset	Name	Bit Pos.	7	6	5	4	3	2	1	0
0x80	CHCTRLA4	7:0		RUNSTDBY					ENABLE	SWRST
		15:8					TRIGSRC[6:0]			
		23:16				TRIGACT[1:0]				
		31:24				THRESHOLD[1:0]		BURSTLEN[3:0]		
0x84	CHCTRLB4	7:0							CMD[1:0]	
0x85	CHPRILVL4	7:0							PRILVL[1:0]	
0x86	CHEVCTRL4	7:0	EVOE	EVIE	EVOMODE[1:0]				EVACT[2:0]	
0x87	...	Reserved								
0x8B	...	Reserved								
0x8C	CHINTENCLR4	7:0						SUSP	TCMPL	TERR
0x8D	CHINTENSET4	7:0						SUSP	TCMPL	TERR
0x8E	CHINTFLAG4	7:0						SUSP	TCMPL	TERR
0x8F	CHSTATUS4	7:0					CRCERR	FERR	BUSY	PEND
0x90	CHCTRLA5	7:0		RUNSTDBY					ENABLE	SWRST
		15:8					TRIGSRC[6:0]			
		23:16				TRIGACT[1:0]				
		31:24				THRESHOLD[1:0]		BURSTLEN[3:0]		
0x94	CHCTRLB5	7:0							CMD[1:0]	
0x95	CHPRILVL5	7:0							PRILVL[1:0]	
0x96	CHEVCTRL5	7:0	EVOE	EVIE	EVOMODE[1:0]				EVACT[2:0]	
0x97	...	Reserved								
0x9B	...	Reserved								
0x9C	CHINTENCLR5	7:0						SUSP	TCMPL	TERR
0x9D	CHINTENSET5	7:0						SUSP	TCMPL	TERR
0x9E	CHINTFLAG5	7:0						SUSP	TCMPL	TERR
0x9F	CHSTATUS5	7:0					CRCERR	FERR	BUSY	PEND
0xA0	CHCTRLA6	7:0		RUNSTDBY					ENABLE	SWRST
		15:8					TRIGSRC[6:0]			
		23:16				TRIGACT[1:0]				
		31:24				THRESHOLD[1:0]		BURSTLEN[3:0]		
0xA4	CHCTRLB6	7:0							CMD[1:0]	
0xA5	CHPRILVL6	7:0							PRILVL[1:0]	
0xA6	CHEVCTRL6	7:0	EVOE	EVIE	EVOMODE[1:0]				EVACT[2:0]	
0xA7	...	Reserved								
0xAB	...	Reserved								
0xAC	CHINTENCLR6	7:0						SUSP	TCMPL	TERR
0xAD	CHINTENSET6	7:0						SUSP	TCMPL	TERR
0xAE	CHINTFLAG6	7:0						SUSP	TCMPL	TERR
0xAF	CHSTATUS6	7:0					CRCERR	FERR	BUSY	PEND
0xB0	CHCTRLA7	7:0		RUNSTDBY					ENABLE	SWRST
		15:8					TRIGSRC[6:0]			
		23:16				TRIGACT[1:0]				
		31:24				THRESHOLD[1:0]		BURSTLEN[3:0]		
0xB4	CHCTRLB7	7:0							CMD[1:0]	
0xB5	CHPRILVL7	7:0							PRILVL[1:0]	
0xB6	CHEVCTRL7	7:0	EVOE	EVIE	EVOMODE[1:0]				EVACT[2:0]	
0xB7	...	Reserved								
0xBB	...	Reserved								
0xBC	CHINTENCLR7	7:0						SUSP	TCMPL	TERR
0xBD	CHINTENSET7	7:0						SUSP	TCMPL	TERR
0xBE	CHINTFLAG7	7:0						SUSP	TCMPL	TERR
0xBF	CHSTATUS7	7:0					CRCERR	FERR	BUSY	PEND
0xC0	CHCTRLA8	7:0		RUNSTDBY					ENABLE	SWRST
		15:8					TRIGSRC[6:0]			
		23:16				TRIGACT[1:0]				
		31:24				THRESHOLD[1:0]		BURSTLEN[3:0]		
0xC4	CHCTRLB8	7:0							CMD[1:0]	

.....continued

Offset	Name	Bit Pos.	7	6	5	4	3	2	1	0
0xC5	CHPRILVL8	7:0							PRILVL[1:0]	
0xC6	CHEVCTRL8	7:0	EVOE	EVIE	EVOMODE[1:0]				EVACT[2:0]	
0xC7	...									
0xCB	Reserved									
0xCC	CHINTENCLR8	7:0						SUSP	TCMPL	TERR
0xCD	CHINTENSET8	7:0						SUSP	TCMPL	TERR
0xCE	CHINTFLAG8	7:0						SUSP	TCMPL	TERR
0xCF	CHSTATUS8	7:0					CRCERR	FERR	BUSY	PEND
0xD0	CHCTRLA9	7:0		RUNSTDBY					ENABLE	SWRST
		15:8				TRIGSRC[6:0]				
		23:16			TRIGACT[1:0]					
		31:24			THRESHOLD[1:0]		BURSTLEN[3:0]			
0xD4	CHCTRLB9	7:0						CMD[1:0]		
0xD5	CHPRILVL9	7:0						PRILVL[1:0]		
0xD6	CHEVCTRL9	7:0	EVOE	EVIE	EVOMODE[1:0]			EVACT[2:0]		
0xD7	...									
0xDB	Reserved									
0xDC	CHINTENCLR9	7:0						SUSP	TCMPL	TERR
0xDD	CHINTENSET9	7:0						SUSP	TCMPL	TERR
0xDE	CHINTFLAG9	7:0						SUSP	TCMPL	TERR
0xDF	CHSTATUS9	7:0					CRCERR	FERR	BUSY	PEND
0xE0	CHCTRLA10	7:0		RUNSTDBY					ENABLE	SWRST
		15:8				TRIGSRC[6:0]				
		23:16			TRIGACT[1:0]					
		31:24			THRESHOLD[1:0]		BURSTLEN[3:0]			
0xE4	CHCTRLB10	7:0						CMD[1:0]		
0xE5	CHPRILVL10	7:0						PRILVL[1:0]		
0xE6	CHEVCTRL10	7:0	EVOE	EVIE	EVOMODE[1:0]			EVACT[2:0]		
0xE7	...									
0xEB	Reserved									
0xEC	CHINTENCLR10	7:0						SUSP	TCMPL	TERR
0xED	CHINTENSET10	7:0						SUSP	TCMPL	TERR
0xEE	CHINTFLAG10	7:0						SUSP	TCMPL	TERR
0xEF	CHSTATUS10	7:0					CRCERR	FERR	BUSY	PEND
0xF0	CHCTRLA11	7:0		RUNSTDBY					ENABLE	SWRST
		15:8				TRIGSRC[6:0]				
		23:16			TRIGACT[1:0]					
		31:24			THRESHOLD[1:0]		BURSTLEN[3:0]			
0xF4	CHCTRLB11	7:0						CMD[1:0]		
0xF5	CHPRILVL11	7:0						PRILVL[1:0]		
0xF6	CHEVCTRL11	7:0	EVOE	EVIE	EVOMODE[1:0]			EVACT[2:0]		
0xF7	...									
0xFB	Reserved									
0xFC	CHINTENCLR11	7:0						SUSP	TCMPL	TERR
0xFD	CHINTENSET11	7:0						SUSP	TCMPL	TERR
0xFE	CHINTFLAG11	7:0						SUSP	TCMPL	TERR
0xFF	CHSTATUS11	7:0					CRCERR	FERR	BUSY	PEND
0x0100	CHCTRLA12	7:0		RUNSTDBY					ENABLE	SWRST
		15:8				TRIGSRC[6:0]				
		23:16			TRIGACT[1:0]					
		31:24			THRESHOLD[1:0]		BURSTLEN[3:0]			
0x0104	CHCTRLB12	7:0						CMD[1:0]		
0x0105	CHPRILVL12	7:0						PRILVL[1:0]		
0x0106	CHEVCTRL12	7:0	EVOE	EVIE	EVOMODE[1:0]			EVACT[2:0]		
0x0107	...									
0x010B	Reserved									

.....continued

Offset	Name	Bit Pos.	7	6	5	4	3	2	1	0
0x010C	CHINTENCLR12	7:0						SUSP	TCMPL	TERR
0x010D	CHINTENSET12	7:0						SUSP	TCMPL	TERR
0x010E	CHINTFLAG12	7:0						SUSP	TCMPL	TERR
0x010F	CHSTATUS12	7:0					CRCERR	FERR	BUSY	PEND
0x0110	CHCTRLA13	7:0		RUNSTDBY					ENABLE	SWRST
		15:8					TRIGSRC[6:0]			
		23:16				TRIGACT[1:0]				
		31:24				THRESHOLD[1:0]		BURSTLEN[3:0]		
0x0114	CHCTRLB13	7:0							CMD[1:0]	
0x0115	CHPRILVL13	7:0							PRILVL[1:0]	
0x0116	CHEVCTRL13	7:0	EVOE	EVIE	EVOMODE[1:0]				EVACT[2:0]	
0x0117	Reserved									
...										
0x011B	Reserved									
0x011C	CHINTENCLR13	7:0						SUSP	TCMPL	TERR
0x011D	CHINTENSET13	7:0						SUSP	TCMPL	TERR
0x011E	CHINTFLAG13	7:0						SUSP	TCMPL	TERR
0x011F	CHSTATUS13	7:0					CRCERR	FERR	BUSY	PEND
0x0120	CHCTRLA14	7:0		RUNSTDBY					ENABLE	SWRST
		15:8					TRIGSRC[6:0]			
		23:16				TRIGACT[1:0]				
		31:24				THRESHOLD[1:0]		BURSTLEN[3:0]		
0x0124	CHCTRLB14	7:0							CMD[1:0]	
0x0125	CHPRILVL14	7:0							PRILVL[1:0]	
0x0126	CHEVCTRL14	7:0	EVOE	EVIE	EVOMODE[1:0]				EVACT[2:0]	
0x0127	Reserved									
...										
0x012B	Reserved									
0x012C	CHINTENCLR14	7:0						SUSP	TCMPL	TERR
0x012D	CHINTENSET14	7:0						SUSP	TCMPL	TERR
0x012E	CHINTFLAG14	7:0						SUSP	TCMPL	TERR
0x012F	CHSTATUS14	7:0					CRCERR	FERR	BUSY	PEND
0x0130	CHCTRLA15	7:0		RUNSTDBY					ENABLE	SWRST
		15:8					TRIGSRC[6:0]			
		23:16				TRIGACT[1:0]				
		31:24				THRESHOLD[1:0]		BURSTLEN[3:0]		
0x0134	CHCTRLB15	7:0							CMD[1:0]	
0x0135	CHPRILVL15	7:0							PRILVL[1:0]	
0x0136	CHEVCTRL15	7:0	EVOE	EVIE	EVOMODE[1:0]				EVACT[2:0]	
0x0137	Reserved									
...										
0x013B	Reserved									
0x013C	CHINTENCLR15	7:0						SUSP	TCMPL	TERR
0x013D	CHINTENSET15	7:0						SUSP	TCMPL	TERR
0x013E	CHINTFLAG15	7:0						SUSP	TCMPL	TERR
0x013F	CHSTATUS15	7:0					CRCERR	FERR	BUSY	PEND
0x0140	CHCTRLA16	7:0		RUNSTDBY					ENABLE	SWRST
		15:8					TRIGSRC[6:0]			
		23:16				TRIGACT[1:0]				
		31:24				THRESHOLD[1:0]		BURSTLEN[3:0]		
0x0144	CHCTRLB16	7:0							CMD[1:0]	
0x0145	CHPRILVL16	7:0							PRILVL[1:0]	
0x0146	CHEVCTRL16	7:0	EVOE	EVIE	EVOMODE[1:0]				EVACT[2:0]	
0x0147	Reserved									
...										
0x014B	Reserved									
0x014C	CHINTENCLR16	7:0						SUSP	TCMPL	TERR
0x014D	CHINTENSET16	7:0						SUSP	TCMPL	TERR
0x014E	CHINTFLAG16	7:0						SUSP	TCMPL	TERR
0x014F	CHSTATUS16	7:0					CRCERR	FERR	BUSY	PEND

.....continued

Offset	Name	Bit Pos.	7	6	5	4	3	2	1	0
0x0150	CHCTRLA17	7:0		RUNSTDBY					ENABLE	SWRST
		15:8					TRIGSRC[6:0]			
		23:16				TRIGACT[1:0]				
		31:24				THRESHOLD[1:0]		BURSTLEN[3:0]		
0x0154	CHCTRLB17	7:0							CMD[1:0]	
0x0155	CHPRILVL17	7:0							PRILVL[1:0]	
0x0156	CHEVCTRL17	7:0	EVOE	EVIE	EVOMODE[1:0]				EVACT[2:0]	
0x0157	Reserved									
...										
0x015B										
0x015C	CHINTENCLR17	7:0						SUSP	TCMPL	TERR
0x015D	CHINTENSET17	7:0						SUSP	TCMPL	TERR
0x015E	CHINTFLAG17	7:0						SUSP	TCMPL	TERR
0x015F	CHSTATUS17	7:0					CRCERR	FERR	BUSY	PEND
0x0160	CHCTRLA18	7:0		RUNSTDBY					ENABLE	SWRST
		15:8					TRIGSRC[6:0]			
		23:16				TRIGACT[1:0]				
		31:24				THRESHOLD[1:0]		BURSTLEN[3:0]		
0x0164	CHCTRLB18	7:0							CMD[1:0]	
0x0165	CHPRILVL18	7:0							PRILVL[1:0]	
0x0166	CHEVCTRL18	7:0	EVOE	EVIE	EVOMODE[1:0]				EVACT[2:0]	
0x0167	Reserved									
...										
0x016B										
0x016C	CHINTENCLR18	7:0						SUSP	TCMPL	TERR
0x016D	CHINTENSET18	7:0						SUSP	TCMPL	TERR
0x016E	CHINTFLAG18	7:0						SUSP	TCMPL	TERR
0x016F	CHSTATUS18	7:0					CRCERR	FERR	BUSY	PEND
0x0170	CHCTRLA19	7:0		RUNSTDBY					ENABLE	SWRST
		15:8					TRIGSRC[6:0]			
		23:16				TRIGACT[1:0]				
		31:24				THRESHOLD[1:0]		BURSTLEN[3:0]		
0x0174	CHCTRLB19	7:0							CMD[1:0]	
0x0175	CHPRILVL19	7:0							PRILVL[1:0]	
0x0176	CHEVCTRL19	7:0	EVOE	EVIE	EVOMODE[1:0]				EVACT[2:0]	
0x0177	Reserved									
...										
0x017B										
0x017C	CHINTENCLR19	7:0						SUSP	TCMPL	TERR
0x017D	CHINTENSET19	7:0						SUSP	TCMPL	TERR
0x017E	CHINTFLAG19	7:0						SUSP	TCMPL	TERR
0x017F	CHSTATUS19	7:0					CRCERR	FERR	BUSY	PEND
0x0180	CHCTRLA20	7:0		RUNSTDBY					ENABLE	SWRST
		15:8					TRIGSRC[6:0]			
		23:16				TRIGACT[1:0]				
		31:24				THRESHOLD[1:0]		BURSTLEN[3:0]		
0x0184	CHCTRLB20	7:0							CMD[1:0]	
0x0185	CHPRILVL20	7:0							PRILVL[1:0]	
0x0186	CHEVCTRL20	7:0	EVOE	EVIE	EVOMODE[1:0]				EVACT[2:0]	
0x0187	Reserved									
...										
0x018B										
0x018C	CHINTENCLR20	7:0						SUSP	TCMPL	TERR
0x018D	CHINTENSET20	7:0						SUSP	TCMPL	TERR
0x018E	CHINTFLAG20	7:0						SUSP	TCMPL	TERR
0x018F	CHSTATUS20	7:0					CRCERR	FERR	BUSY	PEND
0x0190	CHCTRLA21	7:0		RUNSTDBY					ENABLE	SWRST
		15:8					TRIGSRC[6:0]			
		23:16				TRIGACT[1:0]				
		31:24				THRESHOLD[1:0]		BURSTLEN[3:0]		
0x0194	CHCTRLB21	7:0							CMD[1:0]	

.....continued										
Offset	Name	Bit Pos.	7	6	5	4	3	2	1	0
0x0195	CHPRILVL21	7:0							PRILVL[1:0]	
0x0196	CHEVCTRL21	7:0	EVOE	EVIE	EVOMODE[1:0]			EVACT[2:0]		
0x0197	...									
0x019B	Reserved									
0x019C	CHINTENCLR21	7:0						SUSP	TCMPL	TERR
0x019D	CHINTENSET21	7:0						SUSP	TCMPL	TERR
0x019E	CHINTFLAG21	7:0						SUSP	TCMPL	TERR
0x019F	CHSTATUS21	7:0					CRCERR	FERR	BUSY	PEND
0x01A0	CHCTRLA22	7:0		RUNSTDBY					ENABLE	SWRST
		15:8				TRIGSRC[6:0]				
		23:16			TRIGACT[1:0]					
		31:24			THRESHOLD[1:0]		BURSTLEN[3:0]			
0x01A4	CHCTRLB22	7:0						CMD[1:0]		
0x01A5	CHPRILVL22	7:0						PRILVL[1:0]		
0x01A6	CHEVCTRL22	7:0	EVOE	EVIE	EVOMODE[1:0]			EVACT[2:0]		
0x01A7	...									
0x01AB	Reserved									
0x01AC	CHINTENCLR22	7:0						SUSP	TCMPL	TERR
0x01AD	CHINTENSET22	7:0						SUSP	TCMPL	TERR
0x01AE	CHINTFLAG22	7:0						SUSP	TCMPL	TERR
0x01AF	CHSTATUS22	7:0					CRCERR	FERR	BUSY	PEND
0x01B0	CHCTRLA23	7:0		RUNSTDBY					ENABLE	SWRST
		15:8				TRIGSRC[6:0]				
		23:16			TRIGACT[1:0]					
		31:24			THRESHOLD[1:0]		BURSTLEN[3:0]			
0x01B4	CHCTRLB23	7:0						CMD[1:0]		
0x01B5	CHPRILVL23	7:0						PRILVL[1:0]		
0x01B6	CHEVCTRL23	7:0	EVOE	EVIE	EVOMODE[1:0]			EVACT[2:0]		
0x01B7	...									
0x01BB	Reserved									
0x01BC	CHINTENCLR23	7:0						SUSP	TCMPL	TERR
0x01BD	CHINTENSET23	7:0						SUSP	TCMPL	TERR
0x01BE	CHINTFLAG23	7:0						SUSP	TCMPL	TERR
0x01BF	CHSTATUS23	7:0					CRCERR	FERR	BUSY	PEND
0x01C0	CHCTRLA24	7:0		RUNSTDBY					ENABLE	SWRST
		15:8				TRIGSRC[6:0]				
		23:16			TRIGACT[1:0]					
		31:24			THRESHOLD[1:0]		BURSTLEN[3:0]			
0x01C4	CHCTRLB24	7:0						CMD[1:0]		
0x01C5	CHPRILVL24	7:0						PRILVL[1:0]		
0x01C6	CHEVCTRL24	7:0	EVOE	EVIE	EVOMODE[1:0]			EVACT[2:0]		
0x01C7	...									
0x01CB	Reserved									
0x01CC	CHINTENCLR24	7:0						SUSP	TCMPL	TERR
0x01CD	CHINTENSET24	7:0						SUSP	TCMPL	TERR
0x01CE	CHINTFLAG24	7:0						SUSP	TCMPL	TERR
0x01CF	CHSTATUS24	7:0					CRCERR	FERR	BUSY	PEND
0x01D0	CHCTRLA25	7:0		RUNSTDBY					ENABLE	SWRST
		15:8				TRIGSRC[6:0]				
		23:16			TRIGACT[1:0]					
		31:24			THRESHOLD[1:0]		BURSTLEN[3:0]			
0x01D4	CHCTRLB25	7:0						CMD[1:0]		
0x01D5	CHPRILVL25	7:0						PRILVL[1:0]		
0x01D6	CHEVCTRL25	7:0	EVOE	EVIE	EVOMODE[1:0]			EVACT[2:0]		
0x01D7	...									
0x01DB	Reserved									

.....continued

Offset	Name	Bit Pos.	7	6	5	4	3	2	1	0	
0x01DC	CHINTENCLR25	7:0						SUSP	TCMPL	TERR	
0x01DD	CHINTENSET25	7:0						SUSP	TCMPL	TERR	
0x01DE	CHINTFLAG25	7:0						SUSP	TCMPL	TERR	
0x01DF	CHSTATUS25	7:0					CRCERR	FERR	BUSY	PEND	
0x01E0	CHCTRLA26	7:0		RUNSTDBY					ENABLE	SWRST	
		15:8				TRIGSRC[6:0]					
		23:16			TRIGACT[1:0]						
		31:24			THRESHOLD[1:0]		BURSTLEN[3:0]				
0x01E4	CHCTRLB26	7:0							CMD[1:0]		
0x01E5	CHPRILVL26	7:0							PRILVL[1:0]		
0x01E6	CHEVCTRL26	7:0	EVOE	EVIE	EVOMODE[1:0]				EVACT[2:0]		
0x01E7	Reserved										
...											
0x01EB	Reserved										
0x01EC	CHINTENCLR26	7:0						SUSP	TCMPL	TERR	
0x01ED	CHINTENSET26	7:0						SUSP	TCMPL	TERR	
0x01EE	CHINTFLAG26	7:0						SUSP	TCMPL	TERR	
0x01EF	CHSTATUS26	7:0					CRCERR	FERR	BUSY	PEND	
0x01F0	CHCTRLA27	7:0		RUNSTDBY					ENABLE	SWRST	
		15:8				TRIGSRC[6:0]					
		23:16			TRIGACT[1:0]						
		31:24			THRESHOLD[1:0]		BURSTLEN[3:0]				
0x01F4	CHCTRLB27	7:0							CMD[1:0]		
0x01F5	CHPRILVL27	7:0							PRILVL[1:0]		
0x01F6	CHEVCTRL27	7:0	EVOE	EVIE	EVOMODE[1:0]				EVACT[2:0]		
0x01F7	Reserved										
...											
0x01FB	Reserved										
0x01FC	CHINTENCLR27	7:0						SUSP	TCMPL	TERR	
0x01FD	CHINTENSET27	7:0						SUSP	TCMPL	TERR	
0x01FE	CHINTFLAG27	7:0						SUSP	TCMPL	TERR	
0x01FF	CHSTATUS27	7:0					CRCERR	FERR	BUSY	PEND	
0x0200	CHCTRLA28	7:0		RUNSTDBY					ENABLE	SWRST	
		15:8				TRIGSRC[6:0]					
		23:16			TRIGACT[1:0]						
		31:24			THRESHOLD[1:0]		BURSTLEN[3:0]				
0x0204	CHCTRLB28	7:0							CMD[1:0]		
0x0205	CHPRILVL28	7:0							PRILVL[1:0]		
0x0206	CHEVCTRL28	7:0	EVOE	EVIE	EVOMODE[1:0]				EVACT[2:0]		
0x0207	Reserved										
...											
0x020B	Reserved										
0x020C	CHINTENCLR28	7:0						SUSP	TCMPL	TERR	
0x020D	CHINTENSET28	7:0						SUSP	TCMPL	TERR	
0x020E	CHINTFLAG28	7:0						SUSP	TCMPL	TERR	
0x020F	CHSTATUS28	7:0					CRCERR	FERR	BUSY	PEND	
0x0210	CHCTRLA29	7:0		RUNSTDBY					ENABLE	SWRST	
		15:8				TRIGSRC[6:0]					
		23:16			TRIGACT[1:0]						
		31:24			THRESHOLD[1:0]		BURSTLEN[3:0]				
0x0214	CHCTRLB29	7:0							CMD[1:0]		
0x0215	CHPRILVL29	7:0							PRILVL[1:0]		
0x0216	CHEVCTRL29	7:0	EVOE	EVIE	EVOMODE[1:0]				EVACT[2:0]		
0x0217	Reserved										
...											
0x021B	Reserved										
0x021C	CHINTENCLR29	7:0						SUSP	TCMPL	TERR	
0x021D	CHINTENSET29	7:0						SUSP	TCMPL	TERR	
0x021E	CHINTFLAG29	7:0						SUSP	TCMPL	TERR	
0x021F	CHSTATUS29	7:0					CRCERR	FERR	BUSY	PEND	



.....continued

Offset	Name	Bit Pos.	7	6	5	4	3	2	1	0	
0x0220	CHCTRLA30	7:0		RUNSTDBY					ENABLE	SWRST	
		15:8					TRIGSRC[6:0]				
		23:16				TRIGACT[1:0]					
		31:24				THRESHOLD[1:0]		BURSTLEN[3:0]			
0x0224	CHCTRLB30	7:0							CMD[1:0]		
0x0225	CHPRILVL30	7:0							PRILVL[1:0]		
0x0226	CHEVCTRL30	7:0	EVOE	EVIE	EVOMODE[1:0]			EVACTION[2:0]			
0x0227	...	Reserved									
0x022B	...	Reserved									
0x022C	CHINTENCLR30	7:0						SUSP	TCMPL	TERR	
0x022D	CHINTENSET30	7:0						SUSP	TCMPL	TERR	
0x022E	CHINTFLAG30	7:0						SUSP	TCMPL	TERR	
0x022F	CHSTATUS30	7:0					CRCERR	FERR	BUSY	PEND	
0x0230	CHCTRLA31	7:0		RUNSTDBY					ENABLE	SWRST	
		15:8					TRIGSRC[6:0]				
		23:16				TRIGACT[1:0]					
		31:24				THRESHOLD[1:0]		BURSTLEN[3:0]			
0x0234	CHCTRLB31	7:0							CMD[1:0]		
0x0235	CHPRILVL31	7:0							PRILVL[1:0]		
0x0236	CHEVCTRL31	7:0	EVOE	EVIE	EVOMODE[1:0]			EVACTION[2:0]			
0x0237	...	Reserved									
0x023B	...	Reserved									
0x023C	CHINTENCLR31	7:0						SUSP	TCMPL	TERR	
0x023D	CHINTENSET31	7:0						SUSP	TCMPL	TERR	
0x023E	CHINTFLAG31	7:0						SUSP	TCMPL	TERR	
0x023F	CHSTATUS31	7:0					CRCERR	FERR	BUSY	PEND	

## 25.6.1 Control

**Name:** CTRL  
**Offset:** 0x00  
**Reset:** 0x0000  
**Property:** PAC Write-Protection, Enable-Protected

Bit	15	14	13	12	11	10	9	8
					LVLEN3	LVLEN2	LVLEN1	LVLEN0
Access					R/W	R/W	R/W	R/W
Reset					0	0	0	0
Bit	7	6	5	4	3	2	1	0
							DMAENABLE	SWRST
Access							R/W	R/W
Reset							0	0

### Bits 8, 9, 10, 11 – LVLENx Priority Level x Enable

When this bit is set, all requests with the corresponding level will be fed into the arbiter block. When cleared, all requests with the corresponding level will be ignored. For details on arbitration schemes, refer to the [Arbitration](#) section. These bits are not enable-protected.

Value	Description
0	Transfer requests for Priority level x will not be handled.
1	Transfer requests for Priority level x will be handled.

### Bit 1 – DMAENABLE DMA Enable

Setting this bit will enable the DMA module. Writing a '0' to this bit will disable the DMA module. When writing a '0' during an ongoing transfer, the bit will not be cleared until the internal data transfer buffer is empty and the DMA transfer is aborted. The internal data transfer buffer will be empty once the ongoing burst transfer is completed.

This bit is not enable-protected.

Value	Description
0	The peripheral is disabled.
1	The peripheral is enabled.

### Bit 0 – SWRST Software Reset

Writing a '0' to this bit has no effect. Writing a '1' to this bit when the DMAC module is disabled (DMAENABLE bit set to "0"), resets all registers in the DMAC (except DBGCTRL) to their initial state. If either the DMAC or CRC module is enabled, the Reset request will be ignored and the DMAC will return an access error.

Value	Description
0	There is no Reset operation ongoing.
1	A Reset operation is ongoing.

## 25.6.2 CRC Control

**Name:** CRCCTRL  
**Offset:** 0x02  
**Reset:** 0x0000  
**Property:** PAC Write-Protection, Enable-Protected

Bit	15	14	13	12	11	10	9	8
	CRCMODE[1:0]		CRCSRC[5:0]					
Access	R/W	R/W	R/W	R/W	R/W	R/W	R/W	R/W
Reset	0	0	0	0	0	0	0	0
Bit	7	6	5	4	3	2	1	0
					CRCPOLY[1:0]		CRCBEATSIZE[1:0]	
Access					R/W	R/W	R/W	R/W
Reset					0	0	0	0

### Bits 15:14 – CRCMODE[1:0] CRC Operating Mode

These bits define the block transfer mode.

Value	Name	Description
0x0	DEFAULT	Default operating mode
0x1	-	Reserved
0x2	CRCMON	Memory CRC monitor operating mode
0x3	CRCGEN	Memory CRC generation operating mode

### Bits 13:8 – CRCSRC[5:0] CRC Input Source

These bits select the input source for generating the CRC. The selected source is locked until either the CRC generation is completed or the CRC module is disabled. This means the CRCSRC cannot be modified when the CRC operation is ongoing. The lock is signaled by the CRCBUSY status bit. The CRC generation complete is generated and signaled from the selected source when used with the DMA Channel.

Value	Name	Description
0x00	DISABLE	No action
0x01	IO	I/O interface
0x02 – 0x1F	-	Reserved
0x20	CHN0	DMA Channel 0
0x21	CHN1	DMA Channel 1
0x22	CHN2	DMA Channel 2
0x23	CHN3	DMA Channel 3
0x24	CHN4	DMA Channel 4
0x25	CHN5	DMA Channel 5
0x26	CHN6	DMA Channel 6
0x27	CHN7	DMA Channel 7
0x28	CHN8	DMA Channel 8
0x29	CHN9	DMA Channel 9
0x2A	CHN10	DMA Channel 10
0x2B	CHN11	DMA Channel 11
0x2C	CHN12	DMA Channel 12
0x2D	CHN13	DMA Channel 13
0x2E	CHN14	DMA Channel 14
0x2F	CHN15	DMA Channel 15
0x30	CHN16	DMA Channel 16
0x31	CHN17	DMA Channel 17

Value	Name	Description
0x32	CHN18	DMA Channel 18
0x33	CHN19	DMA Channel 19
0x34	CHN20	DMA Channel 20
0x35	CHN21	DMA Channel 21
0x36	CHN22	DMA Channel 22
0x37	CHN23	DMA Channel 23
0x38	CHN24	DMA Channel 24
0x39	CHN25	DMA Channel 25
0x3A	CHN26	DMA Channel 26
0x3B	CHN27	DMA Channel 27
0x3C	CHN28	DMA Channel 28
0x3D	CHN29	DMA Channel 29
0x3E	CHN30	DMA Channel 30
0x3F	CHN31	DMA Channel 31

**Bits 3:2 – CRCPOLY[1:0]** CRC Polynomial Type

These bits select the CRC polynomial type.

Value	Name	Description
0x0	CRC16	CRC-16 (CRC-CCITT)
0x1	CRC32	CRC32 (IEEE 802.3)
0x2-0x3	-	Reserved

**Bits 1:0 – CRCBEATSIZE[1:0]** CRC Beat Size

These bits define the size of the data transfer for each bus access when the CRC is used with I/O interface.

Value	Name	Description
0x0	BYTE	8-bit bus transfer
0x1	HWORDB	16-bit bus transfer
0x2	WORD	32-bit bus transfer
0x3	-	Reserved

### 25.6.3 CRC Data Input

**Name:** CRCDATAIN  
**Offset:** 0x04  
**Reset:** 0x00000000  
**Property:** PAC Write Protection

Bit	31	30	29	28	27	26	25	24
	CRCDATAIN[31:24]							
Access	R/W	R/W	R/W	R/W	R/W	R/W	R/W	R/W
Reset	0	0	0	0	0	0	0	0
Bit	23	22	21	20	19	18	17	16
	CRCDATAIN[23:16]							
Access	R/W	R/W	R/W	R/W	R/W	R/W	R/W	R/W
Reset	0	0	0	0	0	0	0	0
Bit	15	14	13	12	11	10	9	8
	CRCDATAIN[15:8]							
Access	R/W	R/W	R/W	R/W	R/W	R/W	R/W	R/W
Reset	0	0	0	0	0	0	0	0
Bit	7	6	5	4	3	2	1	0
	CRCDATAIN[7:0]							
Access	R/W	R/W	R/W	R/W	R/W	R/W	R/W	R/W
Reset	0	0	0	0	0	0	0	0

#### Bits 31:0 – CRCDATAIN[31:0] CRC Data Input

These bits store the data for which the CRC checksum is computed. A new CRC checksum is ready (CRCBEAT+ 1) clock cycles after the CRCDATAIN register is written.

## 25.6.4 CRC Checksum

**Name:** CRCCHKSUM  
**Offset:** 0x08  
**Reset:** 0x00000000  
**Property:** PAC Write Protection, Enable-Protected

The CRCCHKSUM represents the 16- or 32-bit checksum value and the generated CRC. The register is reset to zero by default, but it is possible to reset all bits to one by writing the CRCCHKSUM register directly. It is possible to write this register only when the CRC module is disabled. If CRC-32 is selected and the CRC Status Busy flag is cleared (i.e., CRC generation is completed or aborted), the bit reversed (bit 31 is swapped with bit 0, bit 30 with bit 1, etc.) and complemented result will be read from CRCCHKSUM. If CRC-16 is selected or the CRC Status Busy flag is set (i.e., CRC generation is ongoing), CRCCHKSUM will contain the actual content.

Bit	31	30	29	28	27	26	25	24
	CRCCHKSUM[31:24]							
Access	R/W	R/W	R/W	R/W	R/W	R/W	R/W	R/W
Reset	0	0	0	0	0	0	0	0
Bit	23	22	21	20	19	18	17	16
	CRCCHKSUM[23:16]							
Access	R/W	R/W	R/W	R/W	R/W	R/W	R/W	R/W
Reset	0	0	0	0	0	0	0	0
Bit	15	14	13	12	11	10	9	8
	CRCCHKSUM[15:8]							
Access	R/W	R/W	R/W	R/W	R/W	R/W	R/W	R/W
Reset	0	0	0	0	0	0	0	0
Bit	7	6	5	4	3	2	1	0
	CRCCHKSUM[7:0]							
Access	R/W	R/W	R/W	R/W	R/W	R/W	R/W	R/W
Reset	0	0	0	0	0	0	0	0

### Bits 31:0 – CRCCHKSUM[31:0] CRC Checksum

These bits store the generated CRC result. The 16 MSB bits are always read zero when CRC-16 is enabled.

## 25.6.5 CRC Status

**Name:** CRCSTATUS  
**Offset:** 0x0C  
**Reset:** 0x00  
**Property:** PAC Write-Protection

Bit	7	6	5	4	3	2	1	0
Access						R	R	R/W
Reset						0	0	0

### Bit 2 – CRCERR CRC Error

This bit is read '1' when the memory CRC monitor detects data corruption.

### Bit 1 – CRCZERO CRC Zero

This bit is cleared when a new CRC source is selected.

This bit is set when the CRC generation is complete and the CRC Checksum is zero.

### Bit 0 – CRCBUSY CRC Module Busy

When used with an I/O interface ([CRCCTRL.CRCSRC=0x1](#)):

- This bit is cleared by writing a '1' to it
- This bit is set when the CRC Data Input (CRCDATAIN) register is written
- Writing a '1' to this bit will clear the CRC Module Busy bit
- Writing a '0' to this bit has no effect

When used with a DMA channel ([CRCCTRL.CRCSRC=0x20..,0x3F](#)):

- This bit is cleared when the corresponding DMA channel is disabled
- This bit is set when the corresponding DMA channel is enabled
- Writing a '1' to this bit has no effect
- Writing a '0' to this bit has no effect

## 25.6.6 Debug Control

**Name:** DBGCTRL  
**Offset:** 0x0D  
**Reset:** 0x00  
**Property:** PAC Write Protection

Bit	7	6	5	4	3	2	1	0
								DBGRUN
Access								R/W
Reset								0

### Bit 0 – DBGRUN Debug Run

This bit is not reset by a Software Reset.

This bit controls the functionality when the CPU is halted by an external debugger.

Value	Description
0	The DMAC is halted when the CPU is halted by an external debugger.
1	The DMAC continues normal operation when the CPU is halted by an external debugger.



## 25.6.7 Software Trigger Control

**Name:** SWTRIGCTRL  
**Offset:** 0x10  
**Reset:** 0x00000000  
**Property:** PAC Write-Protection

Bit	31	30	29	28	27	26	25	24
	SWTRIG[31:24]							
Access	R/W	R/W	R/W	R/W	R/W	R/W	R/W	R/W
Reset	0	0	0	0	0	0	0	0
Bit	23	22	21	20	19	18	17	16
	SWTRIG[23:16]							
Access	R/W	R/W	R/W	R/W	R/W	R/W	R/W	R/W
Reset	0	0	0	0	0	0	0	0
Bit	15	14	13	12	11	10	9	8
	SWTRIG[15:8]							
Access	R/W	R/W	R/W	R/W	R/W	R/W	R/W	R/W
Reset	0	0	0	0	0	0	0	0
Bit	7	6	5	4	3	2	1	0
	SWTRIG[7:0]							
Access	R/W	R/W	R/W	R/W	R/W	R/W	R/W	R/W
Reset	0	0	0	0	0	0	0	0

### Bits 31:0 – SWTRIG[31:0] Channel n Software Trigger [n = 31..0]

This bit is cleared when the Channel Pending bit in the Channel Status register ([CHSTATUS.PEND](#)) for the corresponding channel is either set, or by writing a '1' to it.

This bit is set if [CHSTATUS.PEND](#) is already '1' when writing a '1' to that bit.

Writing a '0' to this bit will clear the bit.

Writing a '1' to this bit will generate a DMA software trigger on channel x, if [CHSTATUS.PEND](#)=0 for channel x. [CHSTATUS.PEND](#) will be set and SWTRIG<sub>n</sub> will remain cleared.

## 25.6.8 Priority Control 0

**Name:** PRICTRL0  
**Offset:** 0x14  
**Reset:** 0x40404040  
**Property:** PAC Write-Protection

Bit	31	30	29	28	27	26	25	24
	RRLVLEN3		QOS3[1:0]		LVLPRI3[4:0]			
Access	R/W	R/W	R/W	R/W	R/W	R/W	R/W	R/W
Reset	0	1	0	0	0	0	0	0
Bit	23	22	21	20	19	18	17	16
	RRLVLEN2		QOS2[1:0]		LVLPRI2[4:0]			
Access	R/W	R/W	R/W	R/W	R/W	R/W	R/W	R/W
Reset	0	1	0	0	0	0	0	0
Bit	15	14	13	12	11	10	9	8
	RRLVLEN1		QOS1[1:0]		LVLPRI1[4:0]			
Access	R/W	R/W	R/W	R/W	R/W	R/W	R/W	R/W
Reset	0	1	0	0	0	0	0	0
Bit	7	6	5	4	3	2	1	0
	RRLVLEN0		QOS0[1:0]		LVLPRI0[4:0]			
Access	R/W	R/W	R/W	R/W	R/W	R/W	R/W	R/W
Reset	0	1	0	0	0	0	0	0

### Bits 7, 15, 23, 31 – RRLVLEN Level Round-Robin Scheduling Enable

For details on arbitration schemes, refer to [25.5.2.4. Arbitration](#).

Value	Description
0	Static arbitration scheme for channels with level 0 priority.
1	Round-robin arbitration scheme for channels with level 0 priority.

### Bits 5:6, 13:14, 21:22, 29:30 – QOS Level Quality of Service

Value	Name	Description
0x0	DISABLE	Background (no sensitive operation)
0x1	LOW	Sensitive to bandwidth
0x2	MEDIUM	Sensitive to latency
0x3	HIGH	Critical Latency

### Bits 0:4, 8:12, 16:20, 24:28 – LVLPRI Level Channel Priority Number

When round-robin arbitration is enabled (PRICTRL0.RRLVLEN0=1) for priority level 0, this register holds the channel number of the last DMA channel being granted access as the active channel with priority level 0.

When static arbitration is enabled (PRICTRL0.RRLVLEN0=0) for priority level 0, and the value of this bit group is non-zero, it will not affect the static priority scheme.

This bit group is not reset when round-robin arbitration gets disabled (PRICTRL0.RRLVLEN0 written to '0').

## 25.6.9 Interrupt Pending

**Name:** INTPEND  
**Offset:** 0x20  
**Reset:** 0x0000  
**Property:** -

This register allows the user to identify the lowest DMA channel with pending interrupt. An interrupt that handles several channels should consult the INTPEND register to find out which channel number has priority (ignoring/filtering each channel that has its own interrupt line). An interrupt dedicated to only one channel must not use the INTPEND register.

Bit	15	14	13	12	11	10	9	8
	PEND	BUSY	FERR	CRCERR		SUSP	TCMPL	TERR
Access	R	R	R	R/W		R/W	R/W	R/W
Reset	0	0	0	0		0	0	0
Bit	7	6	5	4	3	2	1	0
				ID[4:0]				
Access				R/W	R/W	R/W	R/W	R/W
Reset				0	0	0	0	0

### Bit 15 – PEND Pending

This bit will read '1' when the channel selected by Channel ID field (ID) is pending.

### Bit 14 – BUSY Busy

This bit will read '1' when the channel selected by Channel ID field (ID) is busy.

### Bit 13 – FERR Fetch Error

This bit will read '1' when the channel selected by Channel ID field (ID) fetched an invalid descriptor.

### Bit 12 – CRCERR CRC Error

This bit will read '1' when the channel selected by Channel ID field (ID) has a CRC Error Status Flag bit set, and is set when the CRC monitor detects data corruption.

Writing a '0' to this bit has no effect.

Writing a '1' to this bit will clear it. It will also clear the corresponding flag in the Channel n Interrupt Flag Status and Clear register (CHINTFLAGn), where n is determined by the Channel ID bit field (ID).

### Bit 10 – SUSP Channel Suspend

This bit will read '1' when the channel selected by Channel ID field (ID) has pending Suspend interrupt.

Writing a '0' to this bit has no effect.

Writing a '1' to this bit will clear it. It will also clear the corresponding flag in the Channel n Interrupt Flag Status and Clear register (CHINTFLAGn), where n is determined by the Channel ID bit field (ID).

### Bit 9 – TCMPL Transfer Complete

This bit will read '1' when the channel selected by Channel ID field (ID) has pending Transfer Complete interrupt.

Writing a '0' to this bit has no effect.

Writing a '1' to this bit will clear it. It will also clear the corresponding flag in the Channel n Interrupt Flag Status and Clear register (CHINTFLAGn), where n is determined by the Channel ID bit field (ID).

### Bit 8 – TERR Transfer Error

This bit will read '1' when the channel selected by Channel ID field (ID) has pending Transfer Error interrupt.

Writing a '0' to this bit has no effect.

Writing a '1' to this bit will clear it. It will also clear the corresponding flag in the Channel n Interrupt Flag Status and Clear register (CHINTFLAGn), where n is determined by the Channel ID bit field (ID).

**Bits 4:0 – ID[4:0] Channel ID**

These bits store the lowest channel number with pending interrupts. The number is valid if Suspend (SUSP), Transfer Complete (TCMPL) or Transfer Error (TERR) bits are set. The Channel ID field is refreshed when a new channel (with channel number less than the current one) with pending interrupts is detected, or when the application clears the corresponding channel interrupt sources. When no pending channels interrupts are available, these bits will always return zero value when read.

When the bits are written, indirect access to the corresponding Channel Interrupt Flag register is enabled.

## 25.6.10 Interrupt Status

**Name:** INTSTATUS  
**Offset:** 0x24  
**Reset:** 0x00000000  
**Property:** -

Bit	31	30	29	28	27	26	25	24
	CHINT31	CHINT30	CHINT29	CHINT28	CHINT27	CHINT26	CHINT25	CHINT24
Access	R	R	R	R	R	R	R	R
Reset	0	0	0	0	0	0	0	0
Bit	23	22	21	20	19	18	17	16
	CHINT23	CHINT22	CHINT21	CHINT20	CHINT19	CHINT18	CHINT17	CHINT16
Access	R	R	R	R	R	R	R	R
Reset	0	0	0	0	0	0	0	0
Bit	15	14	13	12	11	10	9	8
	CHINT15	CHINT14	CHINT13	CHINT12	CHINT11	CHINT10	CHINT9	CHINT8
Access	R	R	R	R	R	R	R	R
Reset	0	0	0	0	0	0	0	0
Bit	7	6	5	4	3	2	1	0
	CHINT7	CHINT6	CHINT5	CHINT4	CHINT3	CHINT2	CHINT1	CHINT0
Access	R	R	R	R	R	R	R	R
Reset	0	0	0	0	0	0	0	0

**Bits 0, 1, 2, 3, 4, 5, 6, 7, 8, 9, 10, 11, 12, 13, 14, 15, 16, 17, 18, 19, 20, 21, 22, 23, 24, 25, 26, 27, 28, 29, 30, 31 - CHINTn** Channel n Pending Interrupt [n=31..0]

This bit is set when Channel n has a pending interrupt/the interrupt request is received.

This bit is cleared when the corresponding Channel n interrupts are disabled or the interrupts sources are cleared.

## 25.6.11 Busy Channels

**Name:** BUSYCH  
**Offset:** 0x28  
**Reset:** 0x00000000  
**Property:** -

Bit	31	30	29	28	27	26	25	24
	BUSYCH31	BUSYCH30	BUSYCH29	BUSYCH28	BUSYCH27	BUSYCH26	BUSYCH25	BUSYCH24
Access	R	R	R	R	R	R	R	R
Reset	0	0	0	0	0	0	0	0
Bit	23	22	21	20	19	18	17	16
	BUSYCH23	BUSYCH22	BUSYCH21	BUSYCH20	BUSYCH19	BUSYCH18	BUSYCH17	BUSYCH16
Access	R	R	R	R	R	R	R	R
Reset	0	0	0	0	0	0	0	0
Bit	15	14	13	12	11	10	9	8
	BUSYCH15	BUSYCH14	BUSYCH13	BUSYCH12	BUSYCH11	BUSYCH10	BUSYCH9	BUSYCH8
Access	R	R	R	R	R	R	R	R
Reset	0	0	0	0	0	0	0	0
Bit	7	6	5	4	3	2	1	0
	BUSYCH7	BUSYCH6	BUSYCH5	BUSYCH4	BUSYCH3	BUSYCH2	BUSYCH1	BUSYCH0
Access	R	R	R	R	R	R	R	R
Reset	0	0	0	0	0	0	0	0

### Bits 0, 1, 2, 3, 4, 5, 6, 7, 8, 9, 10, 11, 12, 13, 14, 15, 16, 17, 18, 19, 20, 21, 22, 23, 24, 25, 26, 27, 28, 29, 30, 31 – BUSYCHn Busy Channel n [n=31..0]

This bit is cleared when the channel trigger action for DMA channel n is complete, when a bus error for DMA channel n is detected, or when DMA channel n is disabled.

This bit is set when DMA channel n starts a DMA transfer.

## 25.6.12 Pending Channels

**Name:** PENDCH  
**Offset:** 0x2C  
**Reset:** 0x00000000  
**Property:** -

Bit	31	30	29	28	27	26	25	24
	PENDCH31	PENDCH30	PENDCH29	PENDCH28	PENDCH27	PENDCH26	PENDCH25	PENDCH24
Access	R	R	R	R	R	R	R	R
Reset	0	0	0	0	0	0	0	0
Bit	23	22	21	20	19	18	17	16
	PENDCH23	PENDCH22	PENDCH21	PENDCH20	PENDCH19	PENDCH18	PENDCH17	PENDCH16
Access	R	R	R	R	R	R	R	R
Reset	0	0	0	0	0	0	0	0
Bit	15	14	13	12	11	10	9	8
	PENDCH15	PENDCH14	PENDCH13	PENDCH12	PENDCH11	PENDCH10	PENDCH9	PENDCH8
Access	R	R	R	R	R	R	R	R
Reset	0	0	0	0	0	0	0	0
Bit	7	6	5	4	3	2	1	0
	PENDCH7	PENDCH6	PENDCH5	PENDCH4	PENDCH3	PENDCH2	PENDCH1	PENDCH0
Access	R	R	R	R	R	R	R	R
Reset	0	0	0	0	0	0	0	0

### Bits 0, 1, 2, 3, 4, 5, 6, 7, 8, 9, 10, 11, 12, 13, 14, 15, 16, 17, 18, 19, 20, 21, 22, 23, 24, 25, 26, 27, 28, 29, 30, 31 – PENDCH Pending Channel n [n=31..0]

This bit is cleared when trigger execution defined by channel trigger action settings for DMA channel n is started, when a bus error for DMA channel n is detected or when DMA channel n is disabled. For details on trigger action settings, refer to CHCTRLB.TRIGACT.

This bit is set when a transfer is pending on DMA channel n.

### 25.6.13 Active Channel and Levels

**Name:** ACTIVE  
**Offset:** 0x30  
**Reset:** 0x00000000  
**Property:** -

Bit	31	30	29	28	27	26	25	24	
	BTCNT[15:8]								
Access	R	R	R	R	R	R	R	R	
Reset	0	0	0	0	0	0	0	0	
Bit	23	22	21	20	19	18	17	16	
	BTCNT[7:0]								
Access	R	R	R	R	R	R	R	R	
Reset	0	0	0	0	0	0	0	0	
Bit	15	14	13	12	11	10	9	8	
	ABUSY			ID[4:0]					
Access	R			R	R	R	R	R	
Reset	0			0	0	0	0	0	
Bit	7	6	5	4	3	2	1	0	
					LVLEX3	LVLEX2	LVLEX1	LVLEX0	
Access					R	R	R	R	
Reset					0	0	0	0	

#### Bits 31:16 – BTCNT[15:0] Active Channel Block Transfer Count

These bits hold the 16-bit block transfer count of the ongoing transfer. This value is stored in the active channel and written back in the corresponding Write-Back channel memory location when the arbiter grants a new channel access. The value is valid only when the active channel Active Busy flag (ABUSY) is set.

#### Bit 15 – ABUSY Active Channel Busy

This bit is cleared when the active transfer count is written back in the write-back memory section. This bit is set when the next descriptor transfer count is read from the write-back memory section.

#### Bits 12:8 – ID[4:0] Active Channel ID

These bits hold the channel index currently stored in the active channel registers. The value is updated each time the arbiter grants a new channel transfer access request.

#### Bits 0, 1, 2, 3 – LVLEXx Level x Channel Trigger Request Executing [x=3..0]

This bit is set when a level-x channel trigger request is executing or pending. This bit is cleared when no request is pending or being executed.



## 25.6.14 Descriptor Memory Section Base Address

**Name:** BASEADDR  
**Offset:** 0x34  
**Reset:** 0x00000000  
**Property:** PAC Write Protection, Enable-Protected

Bit	31	30	29	28	27	26	25	24
	BASEADDR[31:24]							
Access	R/W	R/W	R/W	R/W	R/W	R/W	R/W	R/W
Reset	0	0	0	0	0	0	0	0
Bit	23	22	21	20	19	18	17	16
	BASEADDR[23:16]							
Access	R/W	R/W	R/W	R/W	R/W	R/W	R/W	R/W
Reset	0	0	0	0	0	0	0	0
Bit	15	14	13	12	11	10	9	8
	BASEADDR[15:8]							
Access	R/W	R/W	R/W	R/W	R/W	R/W	R/W	R/W
Reset	0	0	0	0	0	0	0	0
Bit	7	6	5	4	3	2	1	0
	BASEADDR[7:0]							
Access	R/W	R/W	R/W	R/W	R/W	R/W	R/W	R/W
Reset	0	0	0	0	0	0	0	0

### Bits 31:0 – BASEADDR[31:0] Descriptor Memory Base Address

These bits store the Descriptor memory section base address. The value must be 64-bit aligned.

## 25.6.15 Write-Back Memory Section Base Address

**Name:** WRBADDR  
**Offset:** 0x38  
**Reset:** 0x00000000  
**Property:** PAC Write Protection, Enable-Protected

Bit	31	30	29	28	27	26	25	24
	WRBADDR[31:24]							
Access	R/W	R/W	R/W	R/W	R/W	R/W	R/W	R/W
Reset	0	0	0	0	0	0	0	0
Bit	23	22	21	20	19	18	17	16
	WRBADDR[23:16]							
Access	R/W	R/W	R/W	R/W	R/W	R/W	R/W	R/W
Reset	0	0	0	0	0	0	0	0
Bit	15	14	13	12	11	10	9	8
	WRBADDR[15:8]							
Access	R/W	R/W	R/W	R/W	R/W	R/W	R/W	R/W
Reset	0	0	0	0	0	0	0	0
Bit	7	6	5	4	3	2	1	0
	WRBADDR[7:0]							
Access	R/W	R/W	R/W	R/W	R/W	R/W	R/W	R/W
Reset	0	0	0	0	0	0	0	0

### Bits 31:0 – WRBADDR[31:0] Write-Back Memory Base Address

These bits store the Write-Back memory base address. The value must be 128-bit aligned.

## 25.6.16 Channel Control A

**Name:** CHCTRLA  
**Offset:** 0x40 + n\*0x10 [n=0..31]  
**Reset:** 0x00000000  
**Property:** PAC Write-Protection, Enable-Protected

Bit	31	30	29	28	27	26	25	24
			THRESHOLD[1:0]		BURSTLEN[3:0]			
Access			R/W	R/W	R/W	R/W	R/W	R/W
Reset			0	0	0	0	0	0
Bit	23	22	21	20	19	18	17	16
			TRIGACT[1:0]					
Access			R/W	R/W				
Reset			0	0				
Bit	15	14	13	12	11	10	9	8
			TRIGSRC[6:0]					
Access		R/W	R/W	R/W	R/W	R/W	R/W	R/W
Reset		0	0	0	0	0	0	0
Bit	7	6	5	4	3	2	1	0
		RUNSTDBY					ENABLE	SWRST
Access		R/W					R/W	R/W
Reset		0					0	0

### Bits 29:28 – THRESHOLD[1:0] FIFO Threshold

These bits define the threshold from which the DMA starts to write to the destination. These bits have no effect in the case of single beat transfers.

These bits are not enable-protected.

Value	Name	Description
0x0	1BEAT	Destination write starts after each beat source address read
0x1	2BEATS	Destination write starts after 2-beats source address read
0x2	4BEATS	Destination write starts after 4-beats source address read
0x3	8BEATS	Destination write starts after 8-beats source address read

### Bits 27:24 – BURSTLEN[3:0] Burst Length

These bits define the burst mode.

These bits are not enable-protected.

Value	Name	Description
0x0	SINGLE	Single-beat burst
0x1	2BEAT	2-beats burst length
0x2	3BEAT	3-beats burst length
0x3	4BEAT	4-beats burst length
0x4	5BEAT	5-beats burst length
0x5	6BEAT	6-beats burst length
0x6	7BEAT	7-beats burst length
0x7	8BEAT	8-beats burst length
0x8	9BEAT	9-beats burst length
0x9	10BEAT	10-beats burst length
0xA	11BEAT	11-beats burst length
0xB	12BEAT	12-beats burst length
0xC	13BEAT	13-beats burst length

Value	Name	Description
0xD	14BEAT	14-beats burst length
0xE	15BEAT	15-beats burst length
0xF	16BEAT	16-beats burst length

### Bits 21:20 – TRIGACT[1:0] Trigger Action

These bits define the trigger action used for a transfer.  
These bits are not enable-protected.

Value	Name	Description
0x0	BLOCK	One trigger required for each block transfer
0x1		Reserved
0x2	BURST	One trigger required for each burst transfer
0x3	TRANSACTION	One trigger required for each transaction

### Bits 14:8 – TRIGSRC[6:0] Trigger Source

These bits define the peripheral that will be the source of a trigger.

Index	Instance	Channel	Presentation
0x00	DISABLE		Only software/event triggers
0x01	RTC	TIMESTAMP	DMA RTC timestamp trigger
0x02	DSU	DCC0	DMAC ID for DCC0 register
0x03	DSU	DCC1	DMAC ID for DCC1 register
0x04	SERCOM0	RX	Index of DMA RX trigger
0x05	SERCOM0	TX	Index of DMA TX trigger
0x06	SERCOM1	RX	Index of DMA RX trigger
0x07	SERCOM1	TX	Index of DMA TX trigger
0x08	SERCOM2	RX	Index of DMA RX trigger
0x09	SERCOM2	TX	Index of DMA TX trigger
0x0A	SERCOM3	RX	Index of DMA RX trigger
0x0B	SERCOM3	TX	Index of DMA TX trigger
0x0C	SERCOM4	RX	Index of DMA RX trigger
0x0D	SERCOM4	TX	Index of DMA TX trigger
0x0E	SERCOM5	RX	Index of DMA RX trigger
0x0F	SERCOM5	TX	Index of DMA TX trigger
0x10	SERCOM6	RX	Index of DMA RX trigger
0x11	SERCOM6	TX	Index of DMA TX trigger
0x12	SERCOM7	RX	Index of DMA RX trigger
0x13	SERCOM7	TX	Index of DMA TX trigger
0x14	CAN0	DEBUG	DMA CAN Debug Req
0x15	CAN1	DEBUG	DMA CAN Debug Req
0x16	TCC0	OVF	DMA overflow/underflow/retrigger trigger
0x1C - 0x17	TCC0	MC	Indexes of DMA Match/Compare triggers
0x1D	TCC1	OVF	DMA overflow/underflow/retrigger trigger
0x21 - 0x1E	TCC1	MC	Indexes of DMA Match/Compare triggers
0x22	TCC2	OVF	DMA overflow/underflow/retrigger trigger
0x25 - 0x23	TCC2	MC	Indexes of DMA Match/Compare triggers
0x26	TCC3	OVF	DMA overflow/underflow/retrigger trigger
0x28 - 0x27	TCC3	MC	Indexes of DMA Match/Compare triggers
0x29	TCC4	OVF	DMA overflow/underflow/retrigger trigger
0x2B - 0x2A	TCC4	MC	Indexes of DMA Match/Compare triggers
0x2C	TC0	OVF	Indexes of DMA Overflow trigger
0x2E - 0x2D	TC0	MC	Indexes of DMA Match/Compare triggers
0x2F	TC1	OVF	Indexes of DMA Overflow trigger
0x31 - 0x30	TC1	MC	Indexes of DMA Match/Compare triggers
0x32	TC2	OVF	Indexes of DMA Overflow trigger
0x34 - 0x33	TC2	MC	Indexes of DMA Match/Compare triggers

.....continued

Index	Instance	Channel	Presentation
0x35	TC3	OVF	Indexes of DMA Overflow trigger
0x37 - 0x36	TC3	MC	Indexes of DMA Match/Compare triggers
0x38	TC4	OVF	Indexes of DMA Overflow trigger
0x3A - 0x39	TC4	MC	Indexes of DMA Match/Compare triggers
0x3B	TC5	OVF	Indexes of DMA Overflow trigger
0x3D:0x3C	TC5	MC	Indexes of DMA Match/Compare triggers
0x3E	TC6	OVF	Indexes of DMA Overflow trigger
0x40 - 0x3F	TC6	MC	Indexes of DMA Match/Compare triggers
0x41	TC7	OVF	Indexes of DMA Overflow trigger
0x43 - 0x41	TC7	MC	Indexes of DMA Match/Compare triggers
0x44	ADC0	RESRDY	index of DMA RESRDY trigger
0x45	ADC0	SEQ	Index of DMA SEQ trigger
0x46	ADC1	RESRDY	Index of DMA RESRDY trigger
0x47	ADC1	SEQ	Index of DMA SEQ trigger
0x49 - 0x48	DAC	EMPTY	DMA DAC Empty Req
0x4B - 0x4A	DAC	RESRDY	DMA DAC Result Ready Req
0x4D - 0x4C	I2S	RX	Indexes of DMA RX triggers
0x4F - 0x4E	I2S	TX	Indexes of DMA TX triggers
0x50	PCC	RX	Indexes of PCC RX trigger
0x51	AES	WR	DMA DATA Write trigger
0x52	AES	RD	DMA DATA Read trigger
0x53	QSPI	RX	Indexes of QSPI RX trigger
0x54	QSPI	TX	Indexes of QSPI TX trigger

**Bit 6 - RUNSTDBY** Channel run in standby

This bit is used to keep the DMAC channel running in standby mode.  
This bit is not enable-protected.

Value	Description
0	The DMAC channel is halted in standby.
1	The DMAC channel continues to run in standby.

**Bit 1 - ENABLE** Channel Enable

Writing a '0' to this bit during an ongoing transfer, the bit will not be cleared until the internal data transfer buffer is empty and the DMA transfer is aborted. The internal data transfer buffer will be empty once the ongoing burst transfer is completed.  
Writing a '1' to this bit will enable the DMA channel.  
This bit is not enable-protected.

Value	Description
0	DMA channel is disabled.
1	DMA channel is enabled.

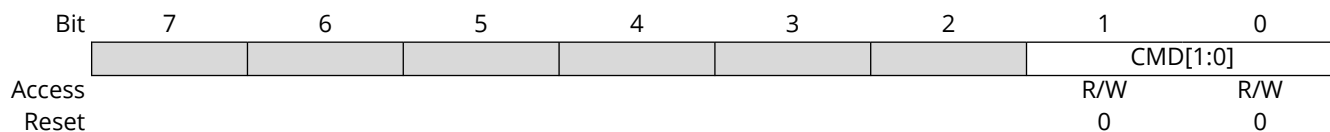
**Bit 0 - SWRST** Channel Software Reset

Writing a '0' to this bit has no effect.  
Writing a '1' to this bit resets the channel registers to their initial state. The bit can be set when the channel is disabled (ENABLE=0). Writing a '1' to this bit will be ignored as long as ENABLE=1. This bit is automatically cleared when the reset is completed.

Value	Description
0	There is no reset operation ongoing.
1	The reset operation is ongoing.

## 25.6.17 Channel Control B

**Name:** CHCTRLB  
**Offset:** 0x44 + n\*0x10 [n=0..31]  
**Reset:** 0x00  
**Property:** PAC Write-Protection



### Bits 1:0 – CMD[1:0] Software Command

These bits define the software commands. Refer to [25.5.3.3. Channel Suspend](#) and [25.5.3.4. Channel Resume and Next Suspend Skip](#).

These bits are not enable-protected.

CMD[1:0]	Name	Description
0x0	NOACT	No action
0x1	SUSPEND	Channel suspend operation
0x2	RESUME	Channel resume operation
0x3	-	Reserved

## 25.6.18 Channel Priority Level

**Name:** CHPRILVL  
**Offset:** 0x45 + n\*0x10 [n=0..31]  
**Reset:** 0x00  
**Property:** PAC Write-Protection

Bit	7	6	5	4	3	2	1	0
							PRILVL[1:0]	
Access							R/W	R/W
Reset							0	0

### Bits 1:0 – PRILVL[1:0] Channel Priority Level

These bits define the priority level used for the DMA channel. The available levels are shown below, where a high level has priority over a low level. These bits are not enable-protected.

Value	Name	Description
0x0	LVL0	Channel Priority Level 0 (Lowest Level)
0x1	LVL1	Channel Priority Level 1
0x2	LVL2	Channel Priority Level 2
0x3	LVL3	Channel Priority Level 3 (Highest Level)

## 25.6.19 Channel Event Control

**Name:** CHEVCTRL  
**Offset:** 0x46 + n\*0x10 [n=0..31]  
**Reset:** 0x00  
**Property:** PAC Write-Protection, Enable-Protected

Bit	7	6	5	4	3	2	1	0
	EVOE	EVIE	EVOMODE[1:0]			EVACT[2:0]		
Access	R/W	R/W	R/W	R/W		R/W	R/W	R/W
Reset	0	0	0	0		0	0	0

### Bit 7 – EVOE Channel Event Output Enable

This bit indicates if the Channel event generation is enabled. The event will be generated for every condition defined in the Channel Event Output Selection bits (CHEVCTRL.EVOMODE).

Value	Description
0	Channel event generation is disabled.
1	Channel event generation is enabled.

### Bit 6 – EVIE Channel Event Input Enable

Value	Description
0	Channel event action will not be executed on any incoming event.
1	Channel event action will be executed on any incoming event.

### Bits 5:4 – EVOMODE[1:0] Channel Event Output Mode

These bits define the channel event output selection. For details on event output generation, refer to [25.5.3.6. Event Output Selection](#).

Value	Name	Description
0x0	DEFAULT	Block event output selection. Refer to <a href="#">BTCTRL.EVOSEL</a> for available selections.
0x1	TRIGACT	Ongoing trigger action
0x2–0x3		Reserved

### Bits 2:0 – EVACT[2:0] Channel Event Input Action

These bits define the event input action. The action is executed only if the corresponding EVIE bit in the CHEVCTRL register of the channel is set. For details on event actions, refer to [25.5.3.5. Event Input Actions](#). These bits are available only for channels with event input support.

Value	Name	Description
0x0	NOACT	No action
0x1	TRIG	Transfer and periodic transfer trigger
0x2	CTRIG	Conditional transfer trigger
0x3	CBLOCK	Conditional block transfer
0x4	SUSPEND	Channel suspend operation
0x5	RESUME	Channel resume operation
0x6	SSKIP	Skip next block suspend action
0x7	INCPRI	Increase priority



## 25.6.20 Channel Interrupt Enable Clear

**Name:** CHINTENCLR  
**Offset:** 0x4C + n\*0x10 [n=0..31]  
**Reset:** 0x00  
**Property:** PAC Write-Protection

This register allows the user to disable an interrupt without doing a read-modify-write operation. Changes in this register will also be reflected in the Channel Interrupt Enable Set (CHINTENSET) register.

Bit	7	6	5	4	3	2	1	0
						SUSP	TCMPL	TERR
Access						R/W	R/W	R/W
Reset						0	0	0

### Bit 2 – SUSP Channel Suspend Interrupt Enable

Writing a '0' to this bit has no effect.

Writing a '1' to this bit will clear the Channel Suspend Interrupt Enable bit, which disables the Channel Suspend interrupt.

Value	Description
0	The Channel Suspend interrupt is disabled.
1	The Channel Suspend interrupt is enabled.

### Bit 1 – TCMPL Channel Transfer Complete Interrupt Enable

Writing a '0' to this bit has no effect.

Writing a '1' to this bit will clear the Channel Transfer Complete Interrupt Enable bit, which disables the Channel Transfer Complete interrupt.

Value	Description
0	The Channel Transfer Complete interrupt is disabled. When block action is set to none, the TCMPL flag will not be set when a block transfer is completed.
1	The Channel Transfer Complete interrupt is enabled.

### Bit 0 – TERR Channel Transfer Error Interrupt Enable

Writing a '0' to this bit has no effect.

Writing a '1' to this bit will clear the Channel Transfer Error Interrupt Enable bit, which disables the Channel Transfer Error interrupt.

Value	Description
0	The Channel Transfer Error interrupt is disabled.
1	The Channel Transfer Error interrupt is enabled.

## 25.6.21 Channel Interrupt Enable Set

**Name:** CHINTENSET  
**Offset:** 0x4D + n\*0x10 [n=0..31]  
**Reset:** 0x00  
**Property:** PAC Write-Protection

This register allows the user to enable an interrupt without doing a read-modify-write operation. Changes in this register will also be reflected in the Channel Interrupt Enable Clear (CHINTENCLR) register.

Bit	7	6	5	4	3	2	1	0
						SUSP	TCMPL	TERR
Access						R/W	R/W	R/W
Reset						0	0	0

### Bit 2 – SUSP Channel Suspend Interrupt Enable

Writing a '0' to this bit has no effect.

Writing a '1' to this bit will set the Channel Suspend Interrupt Enable bit, which enables the Channel Suspend interrupt.

Value	Description
0	The Channel Suspend interrupt is disabled.
1	The Channel Suspend interrupt is enabled.

### Bit 1 – TCMPL Channel Transfer Complete Interrupt Enable

Writing a '0' to this bit has no effect.

Writing a '1' to this bit will set the Channel Transfer Complete Interrupt Enable bit, which enables the Channel Transfer Complete interrupt.

Value	Description
0	The Channel Transfer Complete interrupt is disabled.
1	The Channel Transfer Complete interrupt is enabled.

### Bit 0 – TERR Channel Transfer Error Interrupt Enable

Writing a '0' to this bit has no effect.

Writing a '1' to this bit will set the Channel Transfer Error Interrupt Enable bit, which enables the Channel Transfer Error interrupt.

Value	Description
0	The Channel Transfer Error interrupt is disabled.
1	The Channel Transfer Error interrupt is enabled.

## 25.6.22 Channel Interrupt Flag Status and Clear

**Name:** CHINTFLAG  
**Offset:** 0x4E + n\*0x10 [n=0..31]  
**Reset:** 0x00  
**Property:** -

Bit	7	6	5	4	3	2	1	0
Access						SUSP	TCMPL	TERR
Reset						R/W	R/W	R/W
						0	0	0

### Bit 2 – SUSP Channel Suspend

This flag is cleared by writing a '1' to it.

This flag is set when a block transfer with suspend block action is completed, when a software suspend command is executed, when a suspend event is received or when an invalid descriptor is fetched by the DMA.

Writing a '0' to this bit has no effect.

Writing a '1' to this bit will clear the Channel Suspend interrupt flag for the corresponding channel.

For details on available software commands, refer to [CHCTRLB.CMD](#).

For details on available event input actions, refer to [CHCTRLB.EVACT](#).

For details on available block actions, refer to [BTCTRL.BLOCKACT](#).

### Bit 1 – TCMPL Channel Transfer Complete

This flag is cleared by writing a '1' to it.

This flag is set when a block transfer is completed and the corresponding interrupt block action is enabled.

Writing a '0' to this bit has no effect.

Writing a '1' to this bit will clear the Transfer Complete interrupt flag for the corresponding channel.

### Bit 0 – TERR Channel Transfer Error

This flag is cleared by writing a '1' to it.

This flag is set when a bus error is detected during a beat transfer or when the DMAC fetches an invalid descriptor.

Writing a '0' to this bit has no effect.

Writing a '1' to this bit will clear the Transfer Error interrupt flag for the corresponding channel.

### 25.6.23 Channel Status

**Name:** CHSTATUS  
**Offset:** 0x4F + n\*0x10 [n=0..31]  
**Reset:** 0x00  
**Property:** -

Bit	7	6	5	4	3	2	1	0
					CRCERR	FERR	BUSY	PEND
Access					R/W	R	R	R
Reset					0	0	0	0

#### Bit 3 – CRCERR Channel CRC Error

This bit is set when the CRC monitor detects data corruption. This bit is cleared by writing '1' to it, or by clearing the CRC Error bit in the INTPEND register ([INTPEND.CRCERR](#)).

#### Bit 2 – FERR Channel Fetch Error

This bit is cleared when a software resume command is executed.  
 This bit is set when an invalid descriptor is fetched.

#### Bit 1 – BUSY Channel Busy

This bit is cleared when the channel trigger action is completed, when a bus error is detected or when the channel is disabled.  
 This bit is set when the DMA channel starts a DMA transfer.

#### Bit 0 – PEND Channel Pending

This bit is cleared when the channel trigger action is started, when a bus error is detected or when the channel is disabled. For details on trigger action settings, refer to [CHCTRLB.TRIGACT](#).  
 This bit is set when a transfer is pending on the DMA channel, as soon as the transfer request is received.

## 25.7 Register Summary - SRAM

Offset	Name	Bit Pos.	7	6	5	4	3	2	1	0
0x00	BTCTRL	7:0				BLOCKACT[1:0]		EVOSEL[1:0]		VALID
		15:8	STEPSIZE[2:0]			STEPSEL	DSTINC	SRCINC	BEATSIZE[1:0]	
0x02	BTCNT	7:0	BTCNT[7:0]							
		15:8	BTCNT[15:8]							
0x04	SRCADDR	7:0	SRCADDR[7:0]							
		15:8	SRCADDR[15:8]							
		23:16	SRCADDR[23:16]							
		31:24	SRCADDR[31:24]							
0x08	DSTADDR	7:0	DSTADDR[7:0]							
		15:8	DSTADDR[15:8]							
		23:16	DSTADDR[23:16]							
		31:24	DSTADDR[31:24]							
0x0C	DESCADDR	7:0	DESCADDR[7:0]							
		15:8	DESCADDR[15:8]							
		23:16	DESCADDR[23:16]							
		31:24	DESCADDR[31:24]							

## 25.7.1 Block Transfer Control

**Name:** BTCTRL  
**Offset:** 0x00  
**Property:** -

The BTCTRL register offset is relative to (BASEADDR or WRBADDR) + Channel Number \* 0x10

Bit	15	14	13	12	11	10	9	8
	STEPSIZE[2:0]			STEPSEL	DSTINC	SRCINC	BEATSIZE[1:0]	
Access	-	-	-	-	-	-	-	-
Reset	-	-	-	-	-	-	-	-
Bit	7	6	5	4	3	2	1	0
				BLOCKACT[1:0]		EVOSEL[1:0]		VALID
Access	-	-	-	-	-	-	-	-
Reset	-	-	-	-	-	-	-	-

### Bits 15:13 – STEPSIZE[2:0] Address Increment Step Size

These bits select the address increment step size. The setting apply to source or destination address, depending on STEPSEL setting.

Value	Name	Description
0x0	X1	Next ADDR = ADDR + (Beat size in byte) * 1
0x1	X2	Next ADDR = ADDR + (Beat size in byte) * 2
0x2	X4	Next ADDR = ADDR + (Beat size in byte) * 4
0x3	X8	Next ADDR = ADDR + (Beat size in byte) * 8
0x4	X16	Next ADDR = ADDR + (Beat size in byte) * 16
0x5	X32	Next ADDR = ADDR + (Beat size in byte) * 32
0x6	X64	Next ADDR = ADDR + (Beat size in byte) * 64
0x7	X128	Next ADDR = ADDR + (Beat size in byte) * 128

### Bit 12 – STEPSEL Step Selection

This bit selects if source or destination addresses are using the step size settings.

Value	Name	Description
0x0	DST	Step size settings apply to the destination address
0x1	SRC	Step size settings apply to the source address

### Bit 11 – DSTINC Destination Address Increment Enable

Writing a '0' to this bit will disable the destination address incrementation. The address will be kept fixed during the data transfer.

Writing a '1' to this bit will enable the destination address incrementation. By default, the destination address is incremented by 1. If the STEPSEL bit is cleared, flexible step-size settings are available in the STEPSIZE register.

Value	Description
0	The Destination Address Increment is disabled
1	The Destination Address Increment is enabled

### Bit 10 – SRCINC Source Address Increment Enable

Writing a '0' to this bit will disable the source address incrementation. The address will be kept fixed during the data transfer.

Writing a '1' to this bit will enable the source address incrementation. By default, the source address is incremented by 1. If the STEPSEL bit is set, flexible step-size settings are available in the STEPSIZE register.

Value	Description
0	The Source Address Increment is disabled

Value	Description
1	The Source Address Increment is enabled

#### Bits 9:8 – BEATSIZE[1:0] Beat Size

These bits define the size of one beat. A beat is the size of one data transfer bus access, and the setting apply to both read and write accesses.

Value	Name	Description
0x0	BYTE	8-bit bus transfer
0x1	HWORDB	16-bit bus transfer
0x2	WORD	32-bit bus transfer
other		Reserved

#### Bits 4:3 – BLOCKACT[1:0] Block Action

These bits define what actions the DMAC should take after a block transfer has completed.

BLOCKACT[1:0]	Name	Description
0x0	NOACT	Channel will be disabled if it is the last block transfer in the transaction
0x1	INT	Channel will be disabled if it is the last block transfer in the transaction and block interrupt
0x2	SUSPEND	Channel suspend operation is completed
0x3	BOTH	Both channel suspend operation and block interrupt

#### Bits 2:1 – EVOSEL[1:0] Event Output Selection

These bits define the event output selection.

EVOSEL[1:0]	Name	Description
0x0	DISABLE	Event generation disabled
0x1	BLOCK	Event strobe when block transfer complete
0x2		Reserved
0x3	BEAT	Event strobe when beat transfer complete

#### Bit 0 – VALID Descriptor Valid

Writing a '0' to this bit in the Descriptor or Write-Back memory will suspend the DMA channel operation when fetching the corresponding descriptor.

The bit is automatically cleared in the Write-Back memory section when channel is aborted, when an error is detected during the block transfer, or when the block transfer is completed.

Value	Description
0	The descriptor is not valid
1	The descriptor is valid

## 25.7.2 Block Transfer Count

**Name:** BTCNT  
**Offset:** 0x02  
**Property:** -

The BTCNT register offset is relative to (BASEADDR or WRBADDR) + Channel Number \* 0x10

Bit	15	14	13	12	11	10	9	8
	BTCNT[15:8]							
Access	-	-	-	-	-	-	-	-
Reset	-	-	-	-	-	-	-	-
Bit	7	6	5	4	3	2	1	0
	BTCNT[7:0]							
Access	-	-	-	-	-	-	-	-
Reset	-	-	-	-	-	-	-	-

### Bits 15:0 – BTCNT[15:0] Block Transfer Count

This bit group holds the 16-bit block transfer count.

During a transfer, the internal counter value is decremented by one after each beat transfer. The internal counter is written to the corresponding write-back memory section for the DMA channel when the DMA channel loses priority, is suspended or gets disabled. The DMA channel can be disabled by a complete transfer, a transfer error or by software.



### 25.7.3 Block Transfer Source Address

**Name:** SRCADDR  
**Offset:** 0x04  
**Property:** -

The SRCADDR register offset is relative to (BASEADDR or WRBADDR) + Channel Number \* 0x10

Bit	31	30	29	28	27	26	25	24
	SRCADDR[31:24]							
Access	-	-	-	-	-	-	-	-
Reset	-	-	-	-	-	-	-	-
Bit	23	22	21	20	19	18	17	16
	SRCADDR[23:16]							
Access	-	-	-	-	-	-	-	-
Reset	-	-	-	-	-	-	-	-
Bit	15	14	13	12	11	10	9	8
	SRCADDR[15:8]							
Access	-	-	-	-	-	-	-	-
Reset	-	-	-	-	-	-	-	-
Bit	7	6	5	4	3	2	1	0
	SRCADDR[7:0]							
Access	-	-	-	-	-	-	-	-
Reset	-	-	-	-	-	-	-	-

#### Bits 31:0 – SRCADDR[31:0] Transfer Source Address

This bit field holds the block transfer source address.

When source address incrementation is disabled (BTCTRL.SRCINC=0), SRCADDR corresponds to the last beat transfer address in the block transfer.

When source address incrementation is enabled (BTCTRL.SRCINC=1), SRCADDR is calculated as follows:

If BTCTRL.STEPSEL=1:

$$SRCADDR = SRCADDR_{START} + BTCNT \cdot (BEATSIZE + 1) \cdot 2^{STEP\,SIZE}$$

If BTCTRL.STEPSEL=0:

$$SRCADDR = SRCADDR_{START} + BTCNT \cdot (BEATSIZE + 1)$$

- SRCADDR<sub>START</sub> is the source address of the first beat transfer in the block transfer
- BTCNT is the initial number of beats remaining in the block transfer
- BEATSIZE is the configured number of bytes in a beat
- STEP<sub>SIZE</sub> is the configured number of beats for each incrementation

## 25.7.4 Block Transfer Destination Address

**Name:** DSTADDR  
**Offset:** 0x08  
**Property:** -

The DSTADDR register offset is relative to (BASEADDR or WRBADDR) + Channel Number \* 0x10

Bit	31	30	29	28	27	26	25	24
	DSTADDR[31:24]							
Access	-	-	-	-	-	-	-	-
Reset	-	-	-	-	-	-	-	-
Bit	23	22	21	20	19	18	17	16
	DSTADDR[23:16]							
Access	-	-	-	-	-	-	-	-
Reset	-	-	-	-	-	-	-	-
Bit	15	14	13	12	11	10	9	8
	DSTADDR[15:8]							
Access	-	-	-	-	-	-	-	-
Reset	-	-	-	-	-	-	-	-
Bit	7	6	5	4	3	2	1	0
	DSTADDR[7:0]							
Access	-	-	-	-	-	-	-	-
Reset	-	-	-	-	-	-	-	-

### Bits 31:0 – DSTADDR[31:0] Transfer Destination Address

This bit field holds the block transfer destination address.

When destination address incrementation is disabled (BTCTRL.DSTINC=0), DSTADDR corresponds to the last beat transfer address in the block transfer.

When destination address incrementation is enabled (BTCTRL.DSTINC=1), DSTADDR is calculated as follows:

If BTCTRL.STEPSEL=1:

$$DSTADDR = DSTADDR_{START} + BTCNT \cdot (BEATSIZE + 1)$$

If BTCTRL.STEPSEL=0:

$$DSTADDR = DSTADDR_{START} + BTCNT \cdot (BEATSIZE + 1) \cdot 2^{STEPsize}$$

- DSTADDR<sub>START</sub> is the destination address of the first beat transfer in the block transfer
- BTCNT is the initial number of beats remaining in the block transfer
- BEATSIZE is the configured number of bytes in a beat
- STEPsize is the configured number of beats for each incrementation

## 25.7.5 Next Descriptor Address

**Name:** DESCADDR  
**Offset:** 0x0C  
**Property:** -

The DESCADDR register offset is relative to (BASEADDR or WRBADDR) + Channel Number \* 0x10

Bit	31	30	29	28	27	26	25	24
	DESCADDR[31:24]							
Access	-	-	-	-	-	-	-	-
Reset	-	-	-	-	-	-	-	-
Bit	23	22	21	20	19	18	17	16
	DESCADDR[23:16]							
Access	-	-	-	-	-	-	-	-
Reset	-	-	-	-	-	-	-	-
Bit	15	14	13	12	11	10	9	8
	DESCADDR[15:8]							
Access	-	-	-	-	-	-	-	-
Reset	-	-	-	-	-	-	-	-
Bit	7	6	5	4	3	2	1	0
	DESCADDR[7:0]							
Access	-	-	-	-	-	-	-	-
Reset	-	-	-	-	-	-	-	-

### Bits 31:0 – DESCADDR[31:0] Next Descriptor Address

This bit group holds the SRAM address of the next descriptor. The value must be 128-bit aligned. If the value of this SRAM register is 0x00000000, the transaction will be terminated when the DMAC tries to load the next transfer descriptor.

## 26. External Interrupt Controller (EIC)

### 26.1 Overview

The External Interrupt Controller (EIC) allows external pins to be configured as interrupt lines. Each interrupt line can be individually masked and can generate an interrupt on rising, falling, both edges, or on high or low levels. Each external pin has a configurable filter to remove spikes. Also, each external pin can be configured to be asynchronous in order to wake-up the device from Sleep modes where all clocks have been disabled. External pins can generate an event.

A separate Non-Maskable Interrupt (NMI) is supported. It has properties similar to the other external interrupts, but is connected to the NMI request of the CPU, enabling it to interrupt any other Interrupt mode.

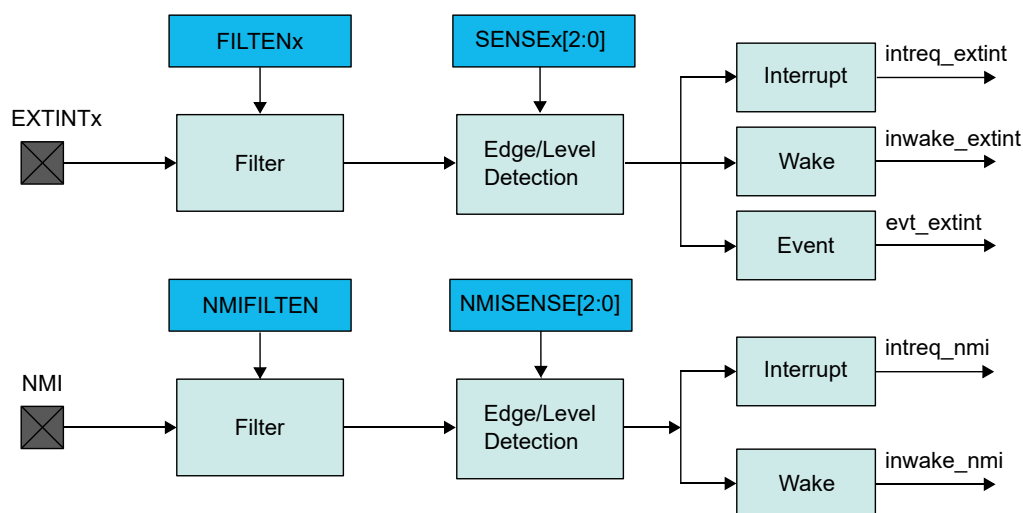
### 26.2 Features

The following are key features of the EIC:

- Up to 16 external pins (EXTINTx), plus one non-maskable pin (NMI)
- Dedicated, Individually Maskable Interrupt for Each Pin
- Interrupt on Rising, Falling, or Both Edges
- Synchronous or Asynchronous Edge Detection mode
- Interrupt pin Debouncing
- Interrupt on High or Low Levels
- Asynchronous Interrupts for Sleep Modes Without Clock
- Filtering of External Pins
- Event Generation from EXTINTx

### 26.3 Block Diagram

Figure 26-1. EIC Block Diagram



### 26.4 Signal Description

Signal Name	Type	Description
EXTINT[15..0]	Digital Input	External interrupt pin
NMI	Digital Input	Non-maskable interrupt pin

One signal may be available on several pins.

## 26.5 Peripheral Dependencies

<b>Peripheral Name</b>	EIC – External Interrupt Controller
<b>Base Address</b>	0x4000_2800 (Peripheral Bus A)
<b>NVIC IRQ Index:Source</b>	12 : EXTINT0, 13 : EXTINT1, 14 : EXTINT2, 15 : EXTINT3, 16 : EXTINT4, 17 : EXTINT5, 18 : EXTINT6, 19 : EXTINT7, 20 : EXTINT8, 21 : EXTINT9, 22 : EXTINT10, 23 : EXTINT11, 24 : EXTINT12, 25 : EXTINT13, 26 : EXTINT14, 27 : EXTINT15
<b>MCLK APB Clock (1)</b>	CLK_EIC_APB, Enabled, APBAMASK.EIC
<b>GCLK Peripheral Channel Index:Clock Name (2)</b>	4 : GCLK_EIC
<b>PAC Peripheral Identifier (PAC.WRCTRL)</b>	10
<b>EVSYS Users (EVSYS.USERm)</b>	n/a
<b>EVSYS Generators (EVSYS.CHANNELn)</b>	18-33 : EIC External Interrupt x, x = 0..15 (EIC_EXTINTx)
<b>Notes:</b>	
	<ol style="list-style-type: none"> <li>1. Clock Name, Default State, Mask Field.</li> <li>2. See GCLK.PCHCTRLm Register, where m = Index.</li> </ol>

### 26.5.1 Power Management

All interrupts are available down to Standby mode, but the EIC can be configured to automatically mask some interrupts in order to prevent device wake-up.

The EIC will continue to operate in any Sleep mode where the selected source clock is running. The EIC's interrupts can be used to wake up the device from sleep modes. Events connected to the Event System can trigger other operations in the system without exiting sleep modes.

### 26.5.2 Clocks

The EIC bus clock (CLK\_EIC\_APB) can be enabled and disabled by the Main Clock Controller, the default state of CLK\_EIC\_APB can be found in the [Peripheral Clock Masking](#) section.

Some optional functions need a peripheral clock, which can either be a generic clock (GCLK\_EIC, for wider frequency selection) or a Ultra Low-Power 32.768 kHz clock (CLK\_ULP32K, for highest power efficiency). One of the clock sources must be configured and enabled before using the peripheral:

GCLK\_EIC is configured and enabled in the [Generic Clock Controller \(GCLK\)](#).

CLK\_ULP32K is provided by the internal Ultra Low-Power ([OSCULP32K](#)) Oscillator in the [OSC32CTRL](#) module.

Both GCLK\_EIC and CLK\_ULP32K are asynchronous to the user interface clock (CLK\_EIC\_APB). Due to this asynchronicity, writes to certain registers will require synchronization between the clock domains. Refer to [Synchronization](#) for further details.

### 26.5.3 Debug Operation

When the CPU is halted in Debug mode, the EIC continues normal operation. If the EIC is configured in a way that requires it to be periodically serviced by the CPU through interrupts or similar, improper operation or data loss may result during debugging.

### 26.5.4 Register Access Protection

All registers with write access can be write-protected optionally by the [Peripheral Access Controller \(PAC\)](#), except for the following registers:

- Interrupt Flag Status and Clear register (INTFLAG)
- Non-Maskable Interrupt Flag Status and Clear register (NMIFLAG)

Optional write protection by the [Peripheral Access Controller \(PAC\)](#) is denoted by the "PAC Write Protection" property in each individual register description.

PAC write protection does not apply to accesses through an external debugger.

## 26.6 Functional Description

### 26.6.1 Principle of Operation

The EIC detects edge or level condition to generate interrupts to the CPU interrupt controller or events to the Event System. Each external interrupt pin (EXTINT) can be filtered using majority vote filtering, clocked by GCLK\_EIC or by CLK\_ULP32K.

### 26.6.2 Basic Operation

#### 26.6.2.1 Initialization

The EIC must be initialized in the following order:

1. Enable CLK\_EIC\_APB.
2. Enable GCLK\_EIC or CLK\_ULP32K when one of the following configuration is selected:
  - The NMI uses edge detection or filtering
  - One or more EXTINT uses filtering
  - One or more EXTINT uses synchronous edge detection
  - One or more EXTINT uses debouncing

GCLK\_EIC is used when a frequency higher than 32.768 kHz is required for filtering.

CLK\_ULP32K is recommended when power consumption is the priority. For CLK\_ULP32K write a '1' to the Clock Selection bit in the Control A register (CTRLA.CKSEL).

3. Configure the EIC input sense and filtering by writing the configuration register (CONFIG0 or CONFIG1).
4. Optionally, enable the Asynchronous mode.
5. Optionally, enable the Debouncer mode.
6. Enable the EIC by writing a '1' to CTRLA.ENABLE.
7. Wait for synchronization completion (SYNCBUSY.ENABLE = 0).
8. If required, configure the NMI by writing the Non-Maskable Interrupt Control register (NMICTRL).

The following bits are enable-protected, that is, it can only be written when the EIC is disabled (CTRLA.ENABLE = 0):

- Clock Selection bit in the Control A register (CTRLA.CKSEL)

The following registers are enable-protected:

- Event Control register (EVCTRL)
- Configuration register (CONFIGn)
- External Interrupt Asynchronous Mode register (26.7.9. ASYNCH)
- Debouncer Enable register (26.7.12. DEBOUNCEN)
- Debounce Prescaler register (26.7.13. DPRESALER)

The enable-protected bits in the CTRLA register can be written simultaneously when setting CTRLA.ENABLE to '1', but not at the same time as CTRLA.ENABLE is being cleared.

Enable-protection is denoted by the "Enable-Protected" property in the register description.

### 26.6.2.2 Enabling, Disabling, and Resetting

The EIC is enabled by writing a '1' to the Enable bit in the Control A register ([CTRLA.ENABLE](#)). The EIC is disabled by writing [CTRLA.ENABLE](#) to '0'.

The EIC is reset by setting the Software Reset bit in the Control register ([CTRLA.SWRST](#)). All registers in the EIC will be reset to their initial state, and the EIC will be disabled.

Refer to the [CTRLA](#) register description for details.

### 26.6.3 External Pin Processing

Each external pin can be configured to generate an interrupt/event on edge detection (rising, falling or both edges) or level detection (high or low). The sense of external interrupt pins is configured by writing the Input Sense x bits in the configuration register ([CONFIGn.SENSEx](#)). The corresponding interrupt flag ([INTFLAG.EXTINT\[x\]](#)) in the Interrupt Flag Status and Clear register ([26.7.8. INTFLAG](#)) is set when the interrupt condition is met.

When the interrupt flag has been cleared in edge-sensitive mode, [INTFLAG.EXTINT\[x\]](#) will only be set if a new interrupt condition is met.

In level-sensitive mode, when interrupt has been cleared, [INTFLAG.EXTINT\[x\]](#) will be set immediately if the [EXTINTx](#) pin still matches the interrupt condition.

Each external pin can be filtered by a majority vote filtering, clocked by [GCLK\\_EIC](#) or [CLK\\_ULP32K](#). Filtering is enabled if bit Filter Enable x in the configuration register ([CONFIGn.FILTENx](#)) is written to '1'. The majority vote filter samples the external pin three times with [GCLK\\_EIC](#) or [CLK\\_ULP32K](#) and outputs the value when two or more samples are equal.

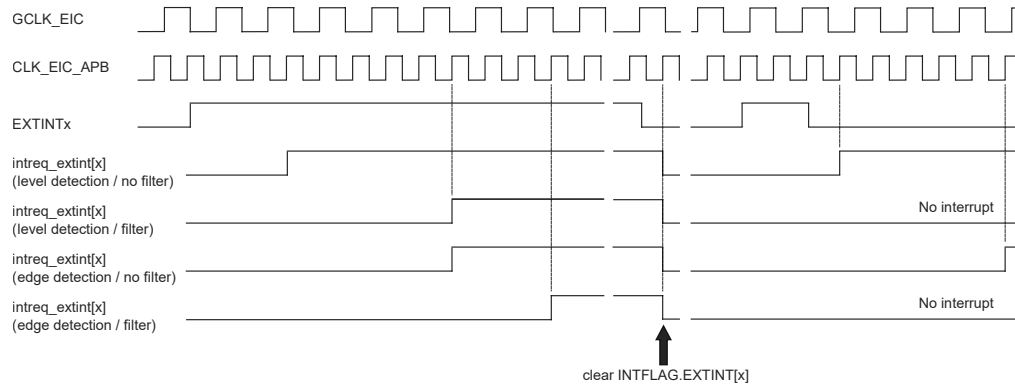
**Table 26-1.** Majority Vote Filter Logic

Samples [0, 1, 2]	Filter Output
[0,0,0]	0
[0,0,1]	0
[0,1,0]	0
[0,1,1]	1
[1,0,0]	0
[1,0,1]	1
[1,1,0]	1
[1,1,1]	1

When an external interrupt is configured for level detection and when filtering is disabled, detection is done asynchronously. Level detection and asynchronous edge detection do not require [GCLK\\_EIC](#) or [CLK\\_ULP32K](#), and can generate asynchronous interrupts and events.

If filtering, synchronous edge detection or debouncing is enabled, the EIC automatically requests [GCLK\\_EIC](#) or [CLK\\_ULP32K](#) to operate. The selection between these two clocks is done by writing the Clock Selection bits in the Control A register ([CTRLA.CKSEL](#)). [GCLK\\_EIC](#) must be enabled in the [GCLK module](#). In these modes the external pin is sampled at the EIC clock rate, thus pulses with duration lower than two EIC clock periods may not be properly detected.

**Figure 26-2. Interrupt Detection Latency by modes (Rising Edge)**



Detection latency depends on the detection mode.

**Table 26-2. Detection Latency**

Detection mode	Latency (worst case)
Level without filter	Five CLK_EIC_APB periods
Level with filter	Four GCLK_EIC/CLK_ULP32K periods + five CLK_EIC_APB periods
Edge without filter	Four GCLK_EIC/CLK_ULP32K periods + five CLK_EIC_APB periods
Edge with filter	Six GCLK_EIC/CLK_ULP32K periods + five CLK_EIC_APB periods

## 26.6.4 Additional Features

### 26.6.4.1 Non-Maskable Interrupt (NMI)

The non-maskable interrupt pin can also generate an interrupt on edge or level detection, but it is configured with the dedicated NMI Control register (NMICTRL). To select the sense for NMI, write to the NMISENSE bit group in the NMI Control register (NMICTRL.NMISENSE). NMI filtering is enabled by writing a '1' to the NMI Filter Enable bit (NMICTRL.NMIFILTEN).

If edge detection or filtering is required, enable GCLK\_EIC or CLK\_ULP32K.

NMI detection is enabled only by the NMICTRL.NMISENSE value, and the EIC module is not required to be enabled.

When an NMI is detected, the Non-maskable Interrupt flag in the NMI Flag Status and Clear register is set (NMIFLAG.NMI). NMI interrupt generation is always enabled, and NMIFLAG.NMI generates an interrupt request when set.

### 26.6.4.2 Asynchronous Edge Detection Mode (No Debouncing)

The EXTINT edge detection operates synchronously or asynchronously, as selected by the Asynchronous Control Mode bit for external pin x in the External Interrupt Asynchronous Mode register (ASYNCH.ASYNCH[x]). The EIC edge detection is operated synchronously when the Asynchronous Control Mode bit (ASYNCH.ASYNCH[x]) is '0' (default value). It is operated asynchronously when ASYNCH.ASYNCH[x] is written to '1'.

In Synchronous Edge Detection mode, the external interrupt (EXTINT) or the Non-Maskable Interrupt (NMI) pins are sampled using the EIC clock as defined by the Clock Selection bit in the Control A register (CTRLA.CKSEL). The External Interrupt flag (INTFLAG.EXTINT[x]) or Non-Maskable Interrupt flag (NMIFLAG.NMI) is set when the last sampled state of the pin differs from the previously sampled state. The EIC clock is needed in this mode.

The Synchronous Edge Detection mode can be used in Idle and Standby Sleep modes.



In Asynchronous Edge Detection mode, the external interrupt (EXTINT) pins or the Non-Maskable Interrupt (NMI) pins set the External Interrupt flag or Non-Maskable Interrupt flag (INTFLAG.EXTINT[x] or NMIFLAG) directly. The EIC clock is not needed in this mode.

The asynchronous edge detection mode can be used in Idle and Standby Sleep modes.

**Note:** In Standby mode, only the first edge will be detected. The following edges are ignored until the system wakes up.

### 26.6.4.3 Interrupt Pin Debouncing

The external interrupt pin (EXTINT) edge detection can use a debouncer to improve input noise immunity. When selected, the debouncer can work in the synchronous mode or the asynchronous mode, depending on the configuration of the ASYNCH.ASYNCH[x] bit for the pin. The debouncer uses the EIC clock as defined by the CTRLA.CKSEL bit to clock the debouncing circuitry. The debouncing time frame is set with the debouncer prescaler DPRESCALER.PRESCALERm, which provides the *low-frequency clock* tick that is used to reject higher frequency signals.

The Debouncing mode for the EXTINT x pin can be selected only if the Sense bits in the configuration register (CONFIGn.SENSEx) are set to RISE, FALL or BOTH. If the debouncing mode for the EXTINT x pin is selected, the filter mode for that pin (CONFIGn.FILTENx) can not be selected.

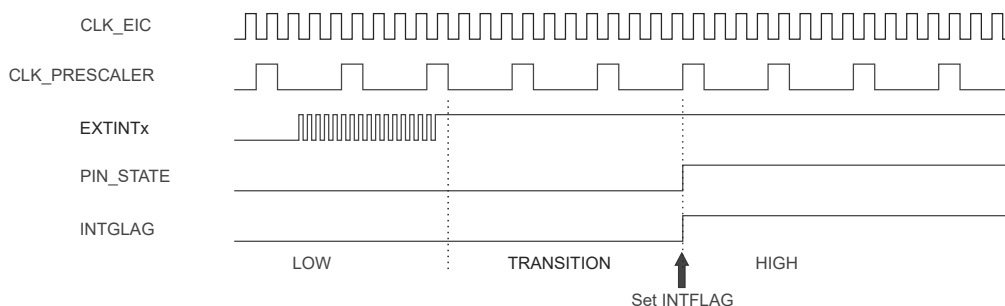
The debouncer manages an internal “valid pin state” that depends on the external interrupt (EXTINT) pin transitions, the debouncing mode, and the debouncer prescaler frequency. The valid pin state reflects the pin value after debouncing. The external interrupt (EXTINT) pin is sampled continuously on EIC clock. The sampled value is evaluated on each *low-frequency clock* tick to detect a transitional edge when the sampled value is different of the current valid pin state. The sampled value is evaluated on each EIC clock when DPRESCALER.TICKON = 0 or on each *low-frequency clock* tick when DPRESCALER.TICKON = 1, to detect a bounce when the sampled value is equal to the current valid pin state. Transitional edge detection increments the transition counter of the EXTINT pin, while bounce detection resets the transition counter. The transition counter must exceed the transition count threshold as defined by the DPRESCALER.STATESm bitfield. In the synchronous mode the threshold is 4 when DPRESCALER.STATESm = 0, or 8 when DPRESCALER.STATESm = 1. In the asynchronous mode the threshold is 4.

The valid pin state for the pins can be accessed by reading the PINSTATE register for both synchronous or asynchronous debouncing mode.

**Synchronous edge detection:** In this mode the external interrupt (EXTINT) pin is sampled continuously on the EIC clock.

- A pin edge transition will be validated when the sampled value is consistently different of the current valid pin state for 4 (or 8 depending on the DPRESCALER.STATESm bit) consecutive ticks of the *low-frequency clock*.
- Any pin sample, at the *low-frequency clock* tick rate, with a value opposite to the current valid pin state will increment the transition counter.
- Any pin sample, at EIC clock rate (when DPRESCALER.TICKON = 0) or the *low-frequency clock* tick (when DPRESCALER.TICKON = 1), with a value identical to the current valid pin state will return the transition counter to zero.
- When the transition counter meets the count threshold, the pin edge transition is validated and the pin state PINSTATE.PINSTATE[x] is changed to the detected level.
- The external interrupt flag (INTFLAG.EXTINT[x]) is set when the pin state PINSTATE.PINSTATE[x] is changed.

**Figure 26-3.** EXTINT Pin Synchronous Debouncing (Rising Edge)

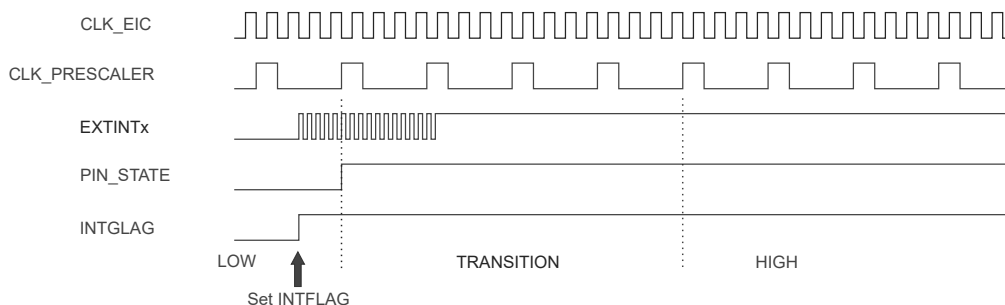


In the Synchronous Edge Detection mode, the EIC clock is required. The Synchronous Edge Detection mode can be used in Idle and Standby Sleep modes.

**Asynchronous edge detection:** In this mode, the external interrupt (EXTINT) pin drives an asynchronous edges detector which triggers any rising or falling edge on the pin:

- Any edge detection that indicates a transition from the current valid pin state will immediately set the valid pin state `PINSTATE.PINSTATE[x]` to the detected level.
- The external interrupt flag (`INTFLAG.EXTINT[x]`) is immediately changed.
- The edge detector will then be idle until no other rising or falling edge transition is detected during 4 consecutive ticks of the low-frequency clock.
- Any rising or falling edge transition detected during the idle state will return the transition counter to 0.
- After 4 consecutive ticks of the low-frequency clock without bounce detected, the edge detector is ready for a new detection.

**Figure 26-4.** EXTINT Pin Asynchronous Debouncing (Rising Edge)



In this mode, the EIC clock is requested. The asynchronous Edge Detection mode can be used in Idle and Standby Sleep modes.

### 26.6.5 Interrupts

The EIC has the following interrupt sources:

- External interrupt (EXTINTx) pins. See [26.6.2. Basic Operation](#).
- Non-maskable interrupt (NMI) pin. See [26.6.4. Additional Features](#).

Each interrupt source has an associated Interrupt flag. The interrupt flag in the Interrupt Flag Status and Clear register (INTFLAG) is set when an Interrupt condition occurs (NMIFLAG for NMI). Each interrupt, except NMI, can be individually enabled by setting the corresponding bit in the Interrupt Enable Set register (`INTENSET = 1`), and disabled by setting the corresponding bit in the Interrupt Enable Clear register (`INTENCLR = 1`). The status of enabled interrupts can be read from either `INTENSET` or `INTENCLR`.

An interrupt request is generated when the interrupt flag is set and the corresponding interrupt is enabled. The interrupt request remains active until the interrupt flag is cleared, the interrupt is disabled, or the EIC is reset. See the INTFLAG register for details on how to clear Interrupt flags. The EIC has one interrupt request line for each external interrupt (EXTINTx) and one line for NMI. The user must read the INTFLAG (or NMIFLAG) register to determine which Interrupt condition is present.

**Notes:**

1. Interrupts must be globally enabled for interrupt requests to be generated.
2. If an external interrupt (EXTINT) is common on two or more I/O pins, only one will be active (the first one programmed).

**26.6.6 Events**

The EIC can generate the following output events:

- External event from pin (EXTINT0-7).

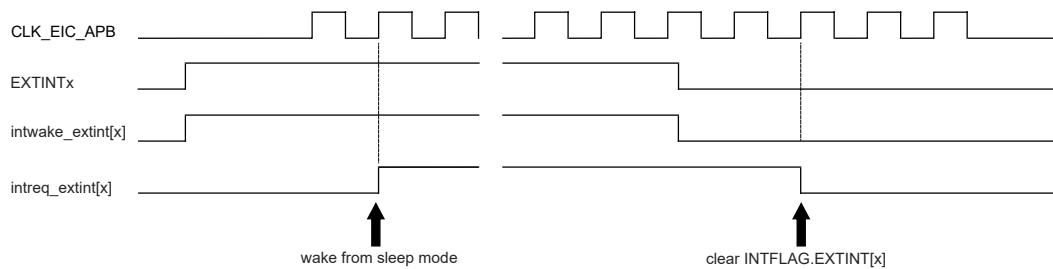
Setting an Event Output Control register (EVCTRL.EXTINTEO) enables the corresponding output event. Clearing this bit disables the corresponding output event. Refer to [Event System](#) for details on configuring the Event System.

When the condition on pin EXTINTx matches the configuration in the CONFIGn.SENSEx bit field, the corresponding event is generated, if enabled.

**26.6.7 Sleep Mode Operation**

In sleep modes, an EXTINTx pin can wake up the device if the corresponding condition matches the configuration in the CONFIGn register, and the corresponding bit in the Interrupt Enable Set register ([26.7.7. INTENSET](#)) is written to '1'.

**Figure 26-5. Wake-up Operation Example (High-Level Detection, No Filter, Interrupt Enable Set)**



**26.6.8 Synchronization**

Due to asynchronicity between the main clock domain and the peripheral clock domains, some registers need to be synchronized when written or read.

The following bits are synchronized when written:

- Software Reset bit in control register ([CTRLA.SWRST](#))
- Enable bit in control register ([CTRLA.ENABLE](#))

Required write synchronization is denoted by the "Write-Synchronized" property in the register description.

## 26.7 Register Summary

Offset	Name	Bit Pos.	7	6	5	4	3	2	1	0	
0x00	CTRLA	7:0				CKSEL			ENABLE	SWRST	
0x01	NMICTRL	7:0				NMIASYNCH	NMIFILTEN		NMISENSE[2:0]		
0x02	NMIFLAG	7:0								NMI	
0x03	Reserved										
0x04	SYNCBUSY	7:0							ENABLE	SWRST	
		15:8									
		23:16									
		31:24									
0x08	EVCTRL	7:0	EXTINTEO[7:0]								
		15:8	EXTINTEO[15:8]								
		23:16									
		31:24									
0x0C	INTENCLR	7:0	EXTINT[7:0]								
		15:8	EXTINT[15:8]								
		23:16									
		31:24									
0x10	INTENSET	7:0	EXTINT[7:0]								
		15:8	EXTINT[15:8]								
		23:16									
		31:24									
0x14	INTFLAG	7:0	EXTINT[7:0]								
		15:8	EXTINT[15:8]								
		23:16									
		31:24									
0x18	ASYNCH	7:0	ASYNCH[7:0]								
		15:8	ASYNCH[15:8]								
		23:16									
		31:24									
0x1C	CONFIG0	7:0	FILTEN1		SENSE1[2:0]		FILTEN0		SENSE0[2:0]		
		15:8	FILTEN3		SENSE3[2:0]		FILTEN2		SENSE2[2:0]		
		23:16	FILTEN5		SENSE5[2:0]		FILTEN4		SENSE4[2:0]		
		31:24	FILTEN7		SENSE7[2:0]		FILTEN6		SENSE6[2:0]		
0x20	CONFIG1	7:0	FILTEN9		SENSE9[2:0]		FILTEN8		SENSE8[2:0]		
		15:8	FILTEN11		SENSE11[2:0]		FILTEN10		SENSE10[2:0]		
		23:16	FILTEN13		SENSE13[2:0]		FILTEN12		SENSE12[2:0]		
		31:24	FILTEN15		SENSE15[2:0]		FILTEN14		SENSE14[2:0]		
0x24 ... 0x2F	Reserved										
0x30	DEBOUNCEN	7:0	DEBOUNCEN[7:0]								
		15:8	DEBOUNCEN[15:8]								
		23:16									
		31:24									
0x34	DPRESCALER	7:0	STATES1		PRESCALER1[2:0]		STATES0		PRESCALER0[2:0]		
		15:8									
		23:16								TICKON	
		31:24									
0x38	PINSTATE	7:0	PINSTATE[7:0]								
		15:8	PINSTATE[15:8]								
		23:16									
		31:24									

## 26.7.1 Control A

**Name:** CTRLA  
**Offset:** 0x00  
**Reset:** 0x00  
**Property:** PAC Write-Protection, Write-Synchronized Bits, Enable-Protected Bits

Bit	7	6	5	4	3	2	1	0
				CKSEL			ENABLE	SWRST
Access				RW			RW	W
Reset				0			0	0

### Bit 4 – CKSEL Clock Selection

The EIC can be clocked either by GCLK\_EIC (when a frequency higher than 32.768 kHz is required for filtering) or by CLK\_ULP32K (when power consumption is the priority). This bit is not Write-Synchronized.

Value	Description
0	The EIC is clocked by GCLK_EIC.
1	The EIC is clocked by CLK_ULP32K.

### Bit 1 – ENABLE Enable

Due to synchronization there is a delay between writing to CTRLA.ENABLE until the peripheral is enabled/disabled. The value written to CTRLA.ENABLE will read back immediately and the Enable bit in the Synchronization Busy register will be set (SYNCBUSY.ENABLE=1). SYNCBUSY.ENABLE will be cleared when the operation is complete.

This bit is not Enable-Protected.  
This bit is Write-Synchronized.



**Important:** SYNCBUSY.ENABLE bit is functional for level detection and asynchronous edge detection modes. For synchronous edge detection mode, it is required to wait for three cycles of the selected clock (GCLK\_EIC or CLK\_ULP32K) once SYNCBUSY.ENABLE bit is cleared; then clear INTFLAG register and configure INTENSET if required.

Value	Description
0	The EIC is disabled.
1	The EIC is enabled.

### Bit 0 – SWRST Software Reset

Writing a '0' to this bit has no effect.

Writing a '1' to this bit resets all registers in the EIC to their initial state, and the EIC will be disabled. Writing a '1' to CTRLA.SWRST will always take precedence, meaning that all other writes in the same write operation will be discarded.

Due to synchronization there is a delay from writing CTRLA.SWRST until the Reset is complete. CTRLA.SWRST and SYNCBUSY.SWRST will both be cleared when the Reset is complete.

**Notes:**

1. When the CTRLA.SWRST is written, the user must poll the SYNCBUSY.SWRST bit to know when the reset operation is complete.
2. During a SWRST, access to registers/bits without the SWRST are disallowed until the SYNCBUSY.SWRST is cleared by hardware.

Value	Description
0	There is no ongoing reset operation.
1	The reset operation is ongoing.

## 26.7.2 Non-Maskable Interrupt Control

**Name:** NMICTRL  
**Offset:** 0x01  
**Reset:** 0x00  
**Property:** PAC Write-Protection

Bit	7	6	5	4	3	2	1	0
				NMIASYNCH	NMIFILTEN	NMISENSE[2:0]		
Access				R/W	R/W	R/W	R/W	R/W
Reset				0	0	0	0	0

### Bit 4 - NMIASYNCH Non-Maskable Interrupt Asynchronous Edge Detection Mode

The NMI edge detection can be operated synchronously or asynchronously to the EIC clock.

Value	Description
0	The NMI edge detection is synchronously operated.
1	The NMI edge detection is asynchronously operated.

### Bit 3 - NMIFILTEN Non-Maskable Interrupt Filter Enable

Value	Description
0	NMI filter is disabled.
1	NMI filter is enabled.

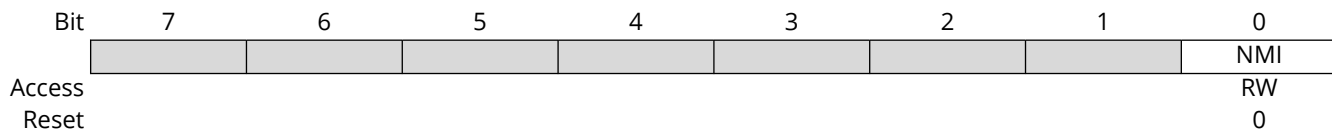
### Bits 2:0 - NMISENSE[2:0] Non-Maskable Interrupt Sense Configuration

These bits define on which edge or level the NMI triggers.

Value	Name	Description
0x0	NONE	No detection
0x1	RISE	Rising-edge detection
0x2	FALL	Falling-edge detection
0x3	BOTH	Both-edge detection
0x4	HIGH	High-level detection
0x5	LOW	Low-level detection
0x6 - 0x7	-	Reserved

### 26.7.3 Non-Maskable Interrupt Flag Status and Clear

**Name:** NMIFLAG  
**Offset:** 0x2  
**Reset:** 0x00  
**Property:** -



#### Bit 0 - NMI Non-Maskable Interrupt

This flag is cleared by writing a '1' to it.

This flag is set when the NMI pin matches the NMI sense configuration, and will generate an interrupt request.

Writing a '0' to this bit has no effect.

## 26.7.4 Synchronization Busy

**Name:** SYNCBUSY  
**Offset:** 0x04  
**Reset:** 0x00000000  
**Property:** -

Bit	31	30	29	28	27	26	25	24
Access								
Reset								
Bit	23	22	21	20	19	18	17	16
Access								
Reset								
Bit	15	14	13	12	11	10	9	8
Access								
Reset								
Bit	7	6	5	4	3	2	1	0
Access							R	R
Reset							0	0

### Bit 1 - ENABLE Enable Synchronization Busy Status



**Important:** SYNCBUSY.ENABLE bit is functional for level detection and asynchronous edge detection modes. For synchronous edge detection mode, it is required to wait for three cycles of the selected clock (GCLK\_EIC or CLK\_ULP32K) once SYNCBUSY.ENABLE bit is cleared; then clear INTFLAG register and configure INTENSET if required.

Value	Description
0	Write synchronization for CTRLA.ENABLE bit is complete.
1	Write synchronization for CTRLA.ENABLE bit is ongoing.

### Bit 0 - SWRST Software Reset Synchronization Busy Status

Value	Description
0	Write synchronization for CTRLA.SWRST bit is complete.
1	Write synchronization for CTRLA.SWRST bit is ongoing.



## 26.7.5 Event Control

**Name:** EVCTRL  
**Offset:** 0x08  
**Reset:** 0x00000000  
**Property:** PAC Write-Protection, Enable-Protected

Bit	31	30	29	28	27	26	25	24
Access								
Reset								
Bit	23	22	21	20	19	18	17	16
Access								
Reset								
Bit	15	14	13	12	11	10	9	8
	EXTINTEO[15:8]							
Access	R/W	R/W	R/W	R/W	R/W	R/W	R/W	R/W
Reset	0	0	0	0	0	0	0	0
Bit	7	6	5	4	3	2	1	0
	EXTINTEO[7:0]							
Access	R/W	R/W	R/W	R/W	R/W	R/W	R/W	R/W
Reset	0	0	0	0	0	0	0	0

### Bits 15:0 – EXTINTEO[15:0] External Interrupt Event Output Enable

The bit x of EXTINTEO enables the event associated with the EXTINTx pin.

Value	Description
0	Event from pin EXTINTx is disabled.
1	Event from pin EXTINTx is enabled and will be generated when EXTINTx pin matches the external interrupt sensing configuration.

## 26.7.6 Interrupt Enable Clear

**Name:** INTENCLR  
**Offset:** 0x0C  
**Reset:** 0x00000000  
**Property:** PAC Write-Protection

This register allows the user to disable an interrupt without doing a read-modify-write operation. Changes in this register will also be reflected in the Interrupt Enable Set register (INTENSET).

Bit	31	30	29	28	27	26	25	24
Access								
Reset								
Bit	23	22	21	20	19	18	17	16
Access								
Reset								
Bit	15	14	13	12	11	10	9	8
	EXTINT[15:8]							
Access	R/W	R/W	R/W	R/W	R/W	R/W	R/W	R/W
Reset	0	0	0	0	0	0	0	0
Bit	7	6	5	4	3	2	1	0
	EXTINT[7:0]							
Access	R/W	R/W	R/W	R/W	R/W	R/W	R/W	R/W
Reset	0	0	0	0	0	0	0	0

### Bits 15:0 – EXTINT[15:0] External Interrupt Enable

The bit x of EXTINT disables the interrupt associated with the EXTINTx pin.

Writing a '0' to bit x has no effect.

Writing a '1' to bit x will clear the External Interrupt Enable bit x, which disables the external interrupt EXTINTx.

Value	Description
0	The external interrupt x is disabled.
1	The external interrupt x is enabled.

## 26.7.7 Interrupt Enable Set

**Name:** INTENSET  
**Offset:** 0x10  
**Reset:** 0x00000000  
**Property:** PAC Write-Protection

This register allows the user to enable an interrupt without doing a read-modify-write operation. Changes in this register will also be reflected in the Interrupt Enable Clear (INTENCLR) register.

Bit	31	30	29	28	27	26	25	24
Access								
Reset								
Bit	23	22	21	20	19	18	17	16
Access								
Reset								
Bit	15	14	13	12	11	10	9	8
Access	EXTINT[15:8]							
Reset	R/W	R/W	R/W	R/W	R/W	R/W	R/W	R/W
Reset	0	0	0	0	0	0	0	0
Bit	7	6	5	4	3	2	1	0
Access	EXTINT[7:0]							
Reset	R/W	R/W	R/W	R/W	R/W	R/W	R/W	R/W
Reset	0	0	0	0	0	0	0	0

### Bits 15:0 – EXTINT[15:0] External Interrupt Enable

The bit x of EXTINT enables the interrupt associated with the EXTINTx pin.

Writing a '0' to bit x has no effect.

Writing a '1' to bit x will set the External Interrupt Enable bit x, which enables the external interrupt EXTINTx.

Value	Description
0	The external interrupt x is disabled.
1	The external interrupt x is enabled.

## 26.7.8 Interrupt Flag Status and Clear

**Name:** INTFLAG  
**Offset:** 0x14  
**Reset:** 0x00000000  
**Property:** -

Bit	31	30	29	28	27	26	25	24
Access								
Reset								
Bit	23	22	21	20	19	18	17	16
Access								
Reset								
Bit	15	14	13	12	11	10	9	8
	EXTINT[15:8]							
Access	R/W	R/W	R/W	R/W	R/W	R/W	R/W	R/W
Reset	0	0	0	0	0	0	0	0
Bit	7	6	5	4	3	2	1	0
	EXTINT[7:0]							
Access	R/W	R/W	R/W	R/W	R/W	R/W	R/W	R/W
Reset	0	0	0	0	0	0	0	0

### Bits 15:0 – EXTINT[15:0] External Interrupt

The flag bit x is cleared by writing a '1' to it.

This flag is set when EXTINTx pin matches the external interrupt sense configuration and will generate an interrupt request if [INTENCLR/SET](#).EXTINT[x] is '1'.

Writing a '0' to this bit has no effect.

Writing a '1' to this bit clears the External Interrupt x flag.

## 26.7.9 External Interrupt Asynchronous Mode

**Name:** ASYNCH  
**Offset:** 0x18  
**Reset:** 0x00000000  
**Property:** PAC Write-Protection, Enable-Protected

Bit	31	30	29	28	27	26	25	24
Access								
Reset								
Bit	23	22	21	20	19	18	17	16
Access								
Reset								
Bit	15	14	13	12	11	10	9	8
	ASYNCH[15:8]							
Access	RW	RW	RW	RW	RW	RW	RW	RW
Reset	0	0	0	0	0	0	0	0
Bit	7	6	5	4	3	2	1	0
	ASYNCH[7:0]							
Access	RW	RW	RW	RW	RW	RW	RW	RW
Reset	0	0	0	0	0	0	0	0

### Bits 15:0 – ASYNCH[15:0] Asynchronous Edge Detection Mode

The bit x of ASYNCH set the Asynchronous Edge Detection Mode for the interrupt associated with the EXTINTx pin.

Value	Description
0	The EXTINT x edge detection is synchronously operated.
1	The EXTINT x edge detection is asynchronously operated.

## 26.7.10 External Interrupt Sense Configuration 0

**Name:** CONFIG0  
**Offset:** 0x1C  
**Reset:** 0x00000000  
**Property:** PAC Write-Protection, Enable-Protected

Bit	31	30	29	28	27	26	25	24	
	FILTEN7		SENSE7[2:0]			FILTEN6		SENSE6[2:0]	
Access	R/W	R/W	R/W	R/W	R/W	R/W	R/W	R/W	
Reset	0	0	0	0	0	0	0	0	
Bit	23	22	21	20	19	18	17	16	
	FILTEN5		SENSE5[2:0]			FILTEN4		SENSE4[2:0]	
Access	R/W	R/W	R/W	R/W	R/W	R/W	R/W	R/W	
Reset	0	0	0	0	0	0	0	0	
Bit	15	14	13	12	11	10	9	8	
	FILTEN3		SENSE3[2:0]			FILTEN2		SENSE2[2:0]	
Access	R/W	R/W	R/W	R/W	R/W	R/W	R/W	R/W	
Reset	0	0	0	0	0	0	0	0	
Bit	7	6	5	4	3	2	1	0	
	FILTEN1		SENSE1[2:0]			FILTEN0		SENSE0[2:0]	
Access	R/W	R/W	R/W	R/W	R/W	R/W	R/W	R/W	
Reset	0	0	0	0	0	0	0	0	

### Bits 3, 7, 11, 15, 19, 23, 27, 31 – FILTENx Filter Enable x [x=7..0]

**Note:** The filter must be disabled if the asynchronous detection is enabled.

Value	Description
0	Filter is disabled for EXTINT[x] input.
1	Filter is enabled for EXTINT[x] input.

### Bits 0:2, 4:6, 8:10, 12:14, 16:18, 20:22, 24:26, 28:30 – SENSEx Input Sense Configuration x [x=7..0]

These bits define on which edge or level the interrupt or event for EXTINT[x] will be generated.

Value	Name	Description
0x0	NONE	No detection
0x1	RISE	Rising-edge detection
0x2	FALL	Falling-edge detection
0x3	BOTH	Both-edge detection
0x4	HIGH	High-level detection
0x5	LOW	Low-level detection
0x6 – 0x7	-	Reserved

## 26.7.11 External Interrupt Sense Configuration 1

**Name:** CONFIG1  
**Offset:** 0x20  
**Reset:** 0x00000000  
**Property:** PAC Write-Protection, Enable-Protected

Bit	31	30	29	28	27	26	25	24	
	FILTEN15		SENSE15[2:0]			FILTEN14		SENSE14[2:0]	
Access	RW	RW	RW	RW	RW	RW	RW	RW	
Reset	0	0	0	0	0	0	0	0	
Bit	23	22	21	20	19	18	17	16	
	FILTEN13		SENSE13[2:0]			FILTEN12		SENSE12[2:0]	
Access	RW	RW	RW	RW	RW	RW	RW	RW	
Reset	0	0	0	0	0	0	0	0	
Bit	15	14	13	12	11	10	9	8	
	FILTEN11		SENSE11[2:0]			FILTEN10		SENSE10[2:0]	
Access	RW	RW	RW	RW	RW	RW	RW	RW	
Reset	0	0	0	0	0	0	0	0	
Bit	7	6	5	4	3	2	1	0	
	FILTEN9		SENSE9[2:0]			FILTEN8		SENSE8[2:0]	
Access	RW	RW	RW	RW	RW	RW	RW	RW	
Reset	0	0	0	0	0	0	0	0	

**Bits 3, 7, 11, 15, 19, 23, 27, 31 – FILTENx** Filter Enable x [x=15..8]

**Note:** The filter must be disabled if the asynchronous detection is enabled.

Value	Description
0	Filter is disabled for EXTINT[x] input.
1	Filter is enabled for EXTINT[x] input.

**Bits 0:2, 4:6, 8:10, 12:14, 16:18, 20:22, 24:26, 28:30 – SENSEx** Input Sense Configuration x [x=15..8]

These bits define on which edge or level the interrupt or event for EXTINT[x] will be generated.

Value	Name	Description
0x0	NONE	No detection
0x1	RISE	Rising-edge detection
0x2	FALL	Falling-edge detection
0x3	BOTH	Both-edge detection
0x4	HIGH	High-level detection
0x5	LOW	Low-level detection
0x6 – 0x7	-	Reserved

## 26.7.12 Debouncer Enable

**Name:** DEBOUNCEN  
**Offset:** 0x30  
**Reset:** 0x00000000  
**Property:** PAC Write-Protection, Enable-Protected

Bit	31	30	29	28	27	26	25	24
Access								
Reset								
Bit	23	22	21	20	19	18	17	16
Access								
Reset								
Bit	15	14	13	12	11	10	9	8
Access	DEBOUNCEN[15:8]							
Reset	RW	RW	RW	RW	RW	RW	RW	RW
Reset	0	0	0	0	0	0	0	0
Bit	7	6	5	4	3	2	1	0
Access	DEBOUNCEN[7:0]							
Reset	RW	RW	RW	RW	RW	RW	RW	RW
Reset	0	0	0	0	0	0	0	0

### Bits 15:0 – DEBOUNCEN[15:0] Debouncer Enable

The bit x of DEBOUNCEN set the Debounce mode for the interrupt associated with the EXTINTx pin.

Value	Description
0	The EXTINT x edge input is not debounced.
1	The EXTINT x edge input is debounced.



### 26.7.13 Debouncer Prescaler

**Name:** DPRESCALER  
**Offset:** 0x34  
**Reset:** 0x00000000  
**Property:** PAC Write-Protection, Enable-Protected

Bit	31	30	29	28	27	26	25	24
Access								
Reset								
Bit	23	22	21	20	19	18	17	16
Access								TICKON
Reset								RW 0
Bit	15	14	13	12	11	10	9	8
Access								
Reset								
Bit	7	6	5	4	3	2	1	0
Access	STATES1	PRESCALER1[2:0]			STATES0	PRESCALER0[2:0]		
Reset	RW 0	RW 0	RW 0	RW 0	RW 0	RW 0	RW 0	RW 0

#### Bit 16 – TICKON Pin Sampler frequency selection

This bit selects the clock used for the sampling of bounce during transition detection.

Value	Description
0	The bounce sampler is using GCLK_EIC.
1	The bounce sampler is using the low frequency clock.

#### Bits 3, 7 – STATESx Debouncer number of states x

This bit selects the number of samples by the debouncer low frequency clock needed to validate a transition from current pin state to next pin state in synchronous debouncing mode for pins EXTINT[7+(8x):8x].

Value	Name	Description
0	LFREQ3	The number of low frequency samples is 3.
1	LFREQ7	The number of low frequency samples is 7.

#### Bits 0:2, 4:6 – PRESCALERx Debouncer Prescaler x

These bits select the debouncer low frequency clock for pins EXTINT[7+(8x):8x].

Value	Name	Description
0x0	DIV2	EIC clock divided by 2
0x1	DIV4	EIC clock divided by 4
0x2	DIV8	EIC clock divided by 8
0x3	DIV16	EIC clock divided by 16
0x4	DIV32	EIC clock divided by 32
0x5	DIV64	EIC clock divided by 64
0x6	DIV128	EIC clock divided by 128
0x7	DIV256	EIC clock divided by 256

## 26.7.14 Pin State

**Name:** PINSTATE  
**Offset:** 0x38  
**Reset:** 0x00000000  
**Property:** -

Bit	31	30	29	28	27	26	25	24
Access								
Reset								
Bit	23	22	21	20	19	18	17	16
Access								
Reset								
Bit	15	14	13	12	11	10	9	8
Access	PINSTATE[15:8]							
Reset	0	0	0	0	0	0	0	0
Bit	7	6	5	4	3	2	1	0
Access	PINSTATE[7:0]							
Reset	0	0	0	0	0	0	0	0

### Bits 15:0 – PINSTATE[15:0] Pin State

These bits return the valid pin state of the debounced external interrupt pin EXTINTx.

## 27. Non-Volatile Memory Controller (NVMCTRL)

### 27.1 Overview

Non-volatile memory (NVM) is a reprogrammable Flash memory that retains program and data storage, even when powered off. The NVM Controller (NVMCTRL) embeds two banks: one bank can be read while the other is programmed (RWW). It is connected to the AHB and APB bus interfaces for system access to the NVM block. The AHB interfaces are used for reads and writes to the NVM block, while the APB interface is used for commands and configuration.

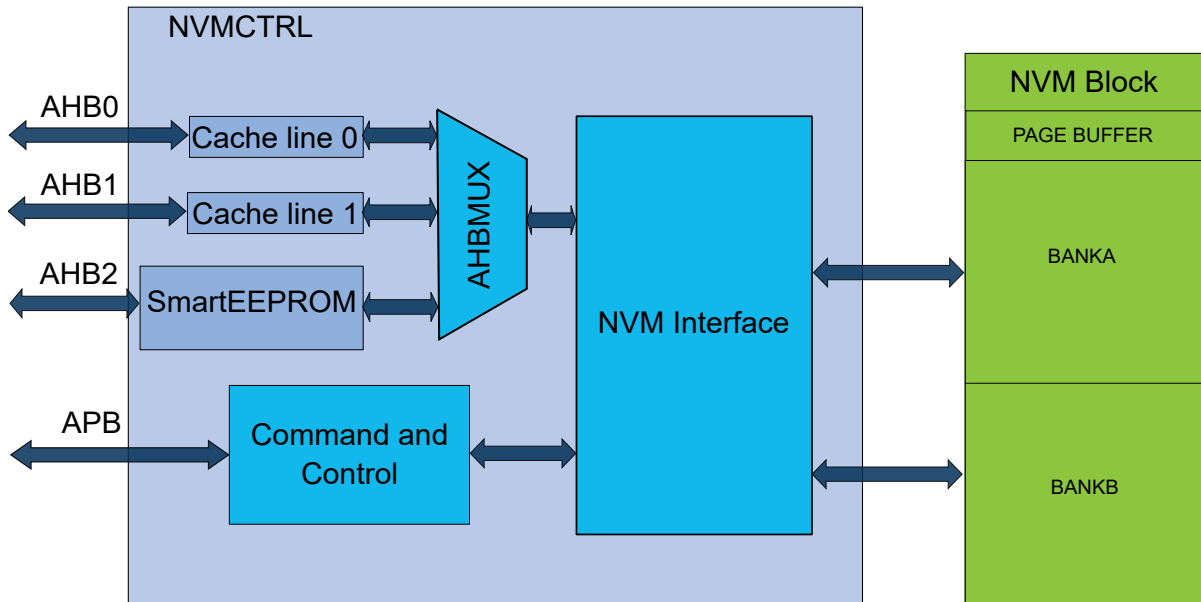
### 27.2 Features

The following are key features of the NVMCTRL module:

- Two 32-bit AHB interfaces for reads and writes in the NVM main address space
- SmartEEPROM (integrated EEPROM emulation algorithm)
- Read-while-write (Any bank can be read while programming the other one)
- All NVM sections are memory mapped to the AHB, including calibration and system configuration
- 32-bit APB interface for commands and control
- Programmable wait states for read optimization
- 32 regions can be individually protected or unprotected
- Additional protection for boot loader
- Supports device protection through a security bit
- Interface to Power Manager to power-down Flash blocks while in sleep modes
- Can optionally wake up on exit from sleep or on first access
- Single line cache per AHB interface
- Dual bank for safer application upgrade
- Immutable Boot support using Chip Erase Hard Lock, Boot Protect Hard Lock and Security Bit commands
- Boot Read Protection
- Error Correction Code (ECC)

## 27.3 Block Diagram

Figure 27-1. Block Diagram



## 27.4 Peripheral Dependencies

<b>Peripheral Name</b>	NVMCTRL – Nonvolatile Memory Controller
<b>Base Address</b>	0x4100_4000 (Peripheral Bus B)
<b>NVIC IRQ Index:Source</b>	29 : DONE , ADDRE, PROGE, LOCKE, ECCSE, ECCDE, NVME, SUSPE 30 : SEESFULL, SEESOVF, SEEWRC
<b>MCLK APB Clock (1)</b>	CLK_NVMCTRL_AHB, Enabled, AHBMASK.NVMCTRL CLK_NVMCTRL_APB, Enabled, APBBMASK.NVMCTRL CLK_NVMCTRL_CACHE, Enabled, AHBMASK.NVMCTRL.CACHE CLK_NVMCTRL_SMEEPROM, Enabled, AHBMASK.NVMCTRL_SMEEPROM
<b>GCLK Peripheral Channel Index:Clock Name</b>	n/a
<b>PAC Peripheral Identifier (PAC.WRCTRL)</b>	34
<b>Note:</b>	1. Clock Name, Default State, Mask Field.

### 27.4.1 Power Management

The NVMCTRL will continue to operate in any sleep mode where the selected source clock is running. The NVMCTRL interrupts can be used to wake up the device from sleep modes.

The NVM block can be put into a low-power mode either automatically when the [Power Manager](#) enters standby mode, or when the SPRM command is issued. The NVMCTRL can wake-up when the Power Manager leaves sleep mode or on AHB access or when a command requires the NVM to be active. This is based on the Control A register (CTRLA) PRM bit setting. Read the CTRLA register description for more details.

NVM wake-up time can be traded with static power consumption depending on the PM STDBYCFG.FASTWKUP setting.

## 27.4.2 Clocks

Two synchronous clocks are used by the NVMCTRL. One is provided by the AHB bus (CLK\_NVMCTRL\_AHB) and the other is provided by the APB bus (CLK\_NVMCTRL\_APB). When changing the AHB bus frequency, the user must ensure that the NVM Controller is configured with the proper number of wait states. Refer to the Electrical Characteristics for the exact number of wait states to be used for a particular frequency range. Automatic wait state generation can be used by setting the Auto Wait State bit in the Control A register (NVMCTRL.CTRLA.AUTOWS). Alternatively a custom programmable number of wait states can be set by writing the NVM Read Wait State bits (NVMCTRL.CTRLA.RWS) to optimize performance.

## 27.4.3 DMA

The NVMCTRL supports AHB burst transfers. It is possible to write the page buffer in sequence without AHB re arbitration in case of concurrent AHB writes to the page buffer to guarantee data integrity.

## 27.4.4 Debug Operation

When the CPU is halted in Debug mode, the ECC feature of the NVMCTRL will correct and log ECC errors based on the table below.

**Table 27-1.** ECC Debug Operation

DBGCTRL.ECCELOG	DBGCTRL.ECCDIS	DBGCTRL.ECCDIS
0	0	ECC errors from debugger reads are corrected, but not logged in INTFLAG.
1	0	ECC errors from debugger reads are corrected and logged in INTFLAG.
X	1	ECC errors from debugger reads are neither corrected nor logged in INTFLAG.

Access to the NVM block can be protected by the security bit. In this case, the NVM block will not be accessible. See the section on the NVMCTRL [27.5.10. Security Bit](#) for details.

Debugger illegal NVMCTRL address space read transactions return invalid data.

Debugger illegal NVMCTRL address space write transactions are silently ignored.

## 27.4.5 Register Access Protection

All registers with write-access are optionally write-protected by the [Peripheral Access Controller \(PAC\)](#), except the Interrupt Flag Status and Clear register (INTFLAG).

Optional write protection by the Peripheral Access Controller (PAC) is denoted by the "PAC Write Protection" property in each individual register description.

## 27.5 Functional Description

### 27.5.1 Principle of Operation

The NVM Controller is a Client on the AHB (AHB0, AHB1 and AHB2) and APB buses. It responds to commands, read requests, and write requests based on user configuration. AHB0 and AHB1 allow access to the NVM main address space, the auxiliary space, and the page buffer. AHB2 provides access to the SmartEEPROM interface that indirectly accesses the reserved area in the NVM for EEPROM emulation.

#### 27.5.1.1 Initialization

After power-up, the NVM Controller goes through a power-up sequence. During this time, access to the NVM Controller from the AHB bus is halted. Upon power-up completion, the NVM Controller is operational without any need for user configuration.

#### 27.5.1.2 Software Reset

Software reset is triggered by the SWRST command, and does the following:

- NVM (physical memory) reset
- Device power-up sequence (redo the device calibration)
- Reset all APB configuration registers (and status)

**Note:**

STATUS.READY goes low when the SWRST command starts to execute.

STATUS.READY goes high when the SWRST command has completed.

Any AHB0/1/2 access is stalled until the command has completed.

## 27.5.2 Memory Organization

The memory space is divided as follows:

- The main address space, where 2 physical NVM banks (BANKA and BANKB) are mapped.
- The auxiliary space that contains:
  - The user page (USER)
  - The calibration page (CB)
  - Factory and signature pages (FS)

The BANKA and BANKB can be swapped in the address space. For additional information, refer to the [Memory Bank Swapping](#).

Refer to the ‘Physical Memory Map’ for memory sizes and addresses for each device.

The BANKA, BANKB, and AUX pages have different erase and write granularities, refer to the table below.

**Table 27-2.** Erase and Write Granularity

	Erase Granularity	Write Granularity
BANKA	Block	Quad-word or page
BANKB	Block	Quad-word or page
AUX	Page	Quad-word

The NVM is organized into two banks, each bank is organized into blocks, where each block contains sixteen pages and page size is 512 bytes. The lower blocks in the NVM main address space can be allocated as a boot loader section by using the BOOTPROT fuses, and the upper rows can be allocated to SmartEEPROM.

The NVM memory is separated into six parts:

1. **CB space:**

Contains factory calibration and system configuration information.

- **Address:** 0x00800000
- **Size:** 1 page
- **Property:** Read-Only

2. **FS space:**

Contains the factory signature information.

- **Address:** 0x00806000
- **Size:** 4 pages
- **Property:** Read-Only.

3. **USER space:**

Contains user-defined start-up configuration. The first word is reserved and used during the NVMCTRL start-up to automatically configure the device.

- **Address:** 0x00804000
- **Size:** 1 page
- **Property:** Read-Write

4. **Main address space:**

The main address space is divided into 32 equally sized regions. Each region can be protected against write or erase operation. The 32-bit RUNLOCK register reflects the protection of each region. This register is automatically updated after power-up with the region lock user fuse data found in the NVM LOCKS field. For additional information, refer to the chapter Memories. To lock or unlock a region, the Lock Region (LR) or Unlock Regions (UR) commands can be issued.

- **Address:** 0x00000000
- **Size:** PARAM.NVMP pages.
- **Property:** Read-Write

5. **Bootloader space:**

The bootloader section starts at the beginning of the main address space; Its size is defined by the NVM User Row BOOTPROT[3:0] fuse. It is protected against write or erase operations, except if STATUS.BPDIS is set. Issuing a write or erase command at an address inside the BOOTPROT section sets STATUS.PROGE and STATUS.LOCKE. STATUS.BPDIS can be set by issuing the Set BOOTPROT Disable command (SBPDIS). It is cleared by issuing the Clear BOOTPROT Disable command (CBPDIS). This allows to program a new bootloader without changing the user page and issuing a new NVMCTRL startup sequence to reload the user configuration.



**Important:** The BOOTPROT section is not erased during a Chip-Erase operation even if STATUS.BPDIS is high.

- **Address:** 0x00000000
- **Size:** (15 - STATUS.BOOTPROT) × 8192
- **Property:** Read-Only.

6. **SmartEEPROM raw data space:**

The SmartEEPROM algorithm emulates an EEPROM with a portion of the NVM main. SmartEEPROM raw data is mapped at the end of the main address space. SmartEEPROM allocated space in the main address space is not accessible from AHB0/1. Any AHB access throws a Hardfault exception. Any command issued with ADDR pointing in the SmartEEPROM space is discarded, INTFLAG.DONE and INTFLAG.ADDRE are set in this case.

- **Address:** PARAM.NVMP\*512-2\*SEESTAT.SBLK\*8192
- **Size:** 2\*SEESTAT.SBLK\*8192
- **Property:** Not readable, not writable

Each section has a different protection status, refer to the following table for additional information.

**Table 27-3.** Protection status

Section/Operation	Write protection	Erase protection	Chip-Erase protection
<b>Bootloader</b>	Yes	Yes	Yes
<b>SmartEEPROM</b>	Configurable	Configurable	No
<b>Main Array</b>	Configurable	Configurable	No

### 27.5.3 Memory Bank Swapping

The two physical banks BANKA and BANKB are mapped in the NVM main address space and can be swapped. If STATUS.AFIRST contains '1', then BANKA is mapped to the NVM main address space Base Address, otherwise it is BANKB.

The start address of BANKA & BANKB depends on STATUS.AFIRST and on the size of the Flash. Refer to the 'Physical Memory Map' for memory sizes and addresses for each device.

### 27.5.4 AHBMUX Arbitration

The AHBMUX arbitrates concurrent AHB0, AHB1 and SmartEEPROM accesses using a fixed priority scheme:

- AHB0 has the highest priority
- AHB1 has priority over SmartEEPROM
- SmartEEPROM has priority over AHB2

However, once a transfer has been accepted the AHB data phase must complete, meaning that a transaction can be stalled by a previously granted access with a lower priority. This can occur in Automatic Wait State mode or in Fixed Wait State mode when the Wait state is greater than zero.

AHBMUX does not re-arbitrate AHB burst transactions. This is useful in case of concurrent write transfers to the page buffer. If used in conjunction with the automatic write features (ADW, AQW, APW) and if the burst transfer size is a multiple of the automatic write size, several hosts can write the NVM without implementing any software semaphore checks.

It is possible to force the re-arbitration in case of burst transfers, as follows:

- on AHB0: by writing a '1' to CTRLA.AHBNS0
- on AHB1: by writing a '1' to CTRLA.AHBNS1

### 27.5.5 Region Lock Bits

The NVM main address space is accessible through the AHB0 or AHB1 interfaces, and grouped into 32 equally sized regions regardless of BOOTPROT or SmartEEPROM settings. The region size is dependent on the flash memory size, and is given in the table below. Each region has a dedicated lock bit preventing writing and erasing pages in the region. After production, all regions will be unlocked.

**Table 27-4.** Region Size

Memory Size [KB]	Region Size [KB]
1024	32
512	16
256	8

To lock or unlock a region, the Lock Region and Unlock Region commands are provided. Writing one of these commands will temporarily lock/unlock the region containing the address loaded in the ADDR register. ADDR can be written by software, or the automatically loaded value from a AHB write operation can be used. The new setting will stay in effect until the next reset, or the setting can be changed again using the lock and unlock commands. The current status of the lock can be determined by reading the RUNLOCK register.

To change the default lock/unlock setting for a region, the user page must be written (See Memories chapter). Writing to the auxiliary space will take effect after the next reset. Therefore, a boot of the device is needed for changes in the lock/unlock setting to take effect. Refer to the 'Physical Memory Map' for calibration and auxiliary space address mapping.



## 27.5.6 Command and Data Interface

The NVM Controller is addressable from the APB bus, while the NVM main address space is addressable from the AHB bus. Read and automatic page write operations are performed by addressing the NVM main address space directly, while other operations such as manual page writes and block erase must be performed by issuing commands through the NVM Controller.

To issue a command, the CTRLB.CMD bits must be written along with the CTRLB.CMDEX value (0xA5). STATUS.READY is cleared when a command is issued and set when it has completed. Any command written while STATUS.READY is low will be ignored causing INTFLAG.PROGE to rise. Refer to the CTRLB register description for more details.

Invalid commands are discarded and will set INTFLAG.PROGE and INTFLAG.DONE when issued.

The CTRLA register must be used to control the power reduction mode, read wait states, and the write mode.

Commands that require an address use the ADDR register as an argument. ADDR APB write access is locked by the NVMCTRL while being used internally. For instance if a write operation is started by the NVMCTRL, an APB write is discarded so that the write operation is performed at the correct address. The discarded APB write is signaled by rising INTFLAG.ADDRE. Commands that needs an address will fail if issued while INTFLAG.ADDRE is set, such failure is signaled by rising INTFLAG.PROGE.

The APB ADDR register is updated upon:

- APB writes to the ADDR register address
- AHB writes to the page buffer

ADDR APB writes are discarded and report an INTFLAG.ADDRE error in the following cases:

- When written from APB while a command is reading it
- ADDR APB write access while writing the page buffer (AHB write): ADDR is written upon AHB writes and must stay valid until the page buffer has been written and also until automatic write command has been issued to the command interface when in automatic write mode (WMODE configured as ADW or AQW or AP)
- ADDR APB write access while the command interface reads it
- A command is executed at an illegal address

All commands that require an address are discarded when INTFLAG.ADDRE is set. INTFLAG.PROGE is set in this case. INTFLAG.ADDRE must be cleared before issuing such commands.

### 27.5.6.1 NVM Read

Reading from the NVM main address space is performed via the AHB bus by addressing the NVM main address space or auxiliary address space directly. Read data is available after the number of read wait states has passed as configured in NVMCTRL.CTRLA.RWS.

The number of cycles data are delayed to the AHB bus is determined by the read wait states.

It is not possible to read two banks at the same time. In case of simultaneous read operations, transactions are arbitrated by the internal matrix. Arbitration scheme is fixed priority, AHB0 has the highest priority, AHB1 has priority over AHB2. In case of conflict, AHB interfaces with lower priority are stalled.

Reading in a bank stalls the bus when it is being programmed or erased except when the suspend feature is used.

Reading in a bank does not stall the bus when the other bank is being programmed or erased.

### 27.5.6.2 NVM Write

The entire NVM main address space except the BOOTPROT section can be erased by a debugger Chip Erase command. Alternatively, blocks or pages can be individually erased using the Erase Page

(EP) or Erase Block (EB) depending on the targeted address space. The NVM can be programmed using the Write Page (WP) or Write Quad Word (WQW) commands depending on the targeted address space. AHB writes automatically update the ADDR register. ADDR is write locked by the NVMCTRL until the pagebuffer write completes or until the appropriate write command has been passed to the command interface when in automatic write mode. Write commands are not supported in all address spaces, see the table below. These commands are detailed further in this section.

**Table 27-5.** Supported commands per address space

	WP	WQW	EP	EB
Main Address Space	X	X		X
User Page Address Space		X	X	

Issuing an unsupported command on an address space sets the PROGE interrupt flag.

After programming the NVM main array, the region that the page resides in can be locked to prevent spurious write or erase sequences. Locking is performed on a per-region basis, and so locking a region locks all pages inside the region.

Data to be written to the NVM block is written through AHB and stored in an internal buffer called the page buffer. If the NVMCTRL is busy processing a write command (STATUS.READY=0) then the AHB bus is stalled upon an AHB write until the ongoing command completes. Writing the page buffer is allowed during a block erase operation. The page buffer contains the same number of bytes as an NVM page. Writes to the page buffer must be 32 bits. 16-bit or 8-bit writes to the page buffer is not allowed, and will cause a PAC error. Internally, writes to the page buffer are on a 64-bit basis through the page buffer load data registers (PBLDATA[1] and PBLDATA[0]). The PBLDATA register is a holding register for writes to the same 64-bit page buffer section. Data within a 64-bit section can be written in any order. Crossing a 64-bit boundary will reset the PBLDATA register to all ones. The following example assumes startup from reset where the current address is 0 and PBLDATA is all ones. Only 64 bits of the page buffer are written at a time, but 128 bits are shown for reference.

**Sequential 32-bit write example:**

- 32-bit 0x1 written to address 0
  - Page buffer[127:0] = {0xFFFFFFFF\_FFFFFFFF, PBLDATA[63:32], 0x00000001}
  - PBLDATA[63:0] = {PBLDATA[63:32], 0x00000001}
- 32-bit 0x2 written to address 1
  - Page buffer[127:0] = {0xFFFFFFFF\_FFFFFFFF, 0x00000002, PBLDATA[31:0]}
  - PBLDATA[63:0] = {0x00000002, PBLDATA[31:0]}
- 32-bit 0x3 written to address 2 (crosses 64-bit boundary)
  - Page buffer[127:0] = 0xFFFFFFFF\_00000003\_00000002\_00000001
  - PBLDATA[63:0] = 0xFFFFFFFF\_00000003

Random access writes to 32-bit words within the page buffer will overwrite the opposite word within the same 64-bit section with ones. In the following example, 0x00000001 is overwritten with 0xFFFFFFFF from the third write due to the 64-bit boundary crossing. Only 64 bits of the page buffer are written at a time, but 128 bits are shown for reference.

**Random access 32-bit AHB write example:**

- 32-bit 0x1 written to address 2
  - Page buffer[127:0] = 0xFFFFFFFF\_00000001\_FFFFFFFF\_FFFFFFFF
  - PBLDATA[63:0] = 0xFFFFFFFF\_00000001

- 32-bit 0x2 written to address 1
  - Page buffer[127:0] = 0xFFFFFFFF\_00000001\_00000002\_FFFFFFFF
  - PBLDATA[63:0] = 0x00000002\_FFFFFFFF
- 32-bit 0x3 written to address 3
  - Page buffer[127:0] = 0x00000003\_FFFFFFFF\_00000002\_FFFFFFFF
  - PBLDATA[63:0] = 0x00000003\_0xFFFFFFFF

BANKA and BANKB share the same page buffer. Writing to the NVM block via the AHB bus is buffered in the page buffer. For each AHB bus write, the address is stored in the ADDR register. After the page buffer has been loaded with the required number of bytes, the page can be written to the addressed location by setting CMD to Write Page to write the NVM main array and setting the key value to CMDEX. The LOAD bit in the STATUS register indicates whether the page buffer has been loaded or not. Before writing the page to memory, the accessed block must be erased.

Several write modes are supported and configured through CTRLA.WMODE:

- Manual (MAN):

This is the default configuration. Because the address is automatically stored in ADDR during AHB write operations, the last given address will be present in the ADDR register. There is no need to load the ADDR register manually, unless a different page in memory is to be written. A write should be issued before writing to a different page.

- Automatic Write With Double Word Granularity (ADW):

Automatically writes data with double-word granularity. In this case the WQW command is triggered at the quad-word addressed by ADDR when the last word in a double-word aligned block is written. The other double-word inside the page buffer must be all one. STATUS.READY goes low during the NVM write operation. INTFLAG.DONE flag is set upon completion.

- Automatic Write With Quad Word Granularity (AQW):

Automatically writes data with quad-word granularity. In this case the WQW command is triggered at the quad-word addressed by ADDR when the last word in a quad-word aligned block is written. STATUS.READY goes low during the NVM write operation. INTFLAG.DONE flag is set upon completion.

- Automatic Write With Page Granularity (AP):

Automatically writes data with page granularity. In this case the WP command is triggered at the page addressed by ADDR when the last word in a page aligned block is written. STATUS.READY goes low during the NVM write operation. INTFLAG.DONE flag is set upon completion.

These write modes are supported for writes in the main address space and in the USER page. The USER page doesn't support write page, if the AP mode is selected writes in the USER page will be done in AQW mode. This avoids to change WMODE by software while mixing writes in the main address space and in the USER page.

### Procedure for Manual Page Writes (WMODE=MAN)

The block to be written must be erased before the write command is given.

- Write to the page buffer by addressing the NVM main address space directly
- Write the page buffer to memory:
  - CMD=WP (and CMDEX) to write the full content of the page buffer into the NVM at the page pointed by ADDR
  - CMD=WQW (and CMDEX) to write into the NVM the page buffer quad word pointed by ADDR
- The READY bit in the STATUS register will be low while programming is in progress, and access through the AHB in the same bank will be stalled.

### Procedure for Automatic Writes (WMODE=ADW or AQW or APW)

The block to be written must be erased before the last write to the page buffer is performed. The internal write operation will begin when the second word is written for WMODE = ADW, when the fourth word is written for WMODE = AQW, and when the last word of the page is written for WMODE = APW.

Note that partially written pages must be written with a manual write.

If the command interface is already processing a command, the AHB is stalled until the automatic write command is taken. Therefore it is possible to chain write commands without polling STATUS.READY. For applications that must not stall the AHB bus the automatic write must be used carefully: STATUS.READY must be checked after each double-word or quad-word or page buffer write depending on WMODE before chaining with a new write to avoid stalling the bus.

- Write to the page buffer by addressing the NVM main address space directly.
  - When the word location in the page buffer is written, the double word or quad word or page is automatically written to NVM main address space.
- STATUS.READY will be zero while programming is in progress and access through the AHB will be stalled.

### NVM Write Example (Manual Write mode)

1. Configure manual write for the NVM using WMODE (NVMCTRL.CTRLA).
2. Make sure the NVM is ready to accept a new command (NVMCTRL.STATUS).
3. Clear page buffer ( NVMCTRL.CTRLB).
4. Make sure NVM is ready to accept a new command (NVMCTRL.STATUS).
5. Clear the DONE Flag (NVMCTRL.INTFLAG).
6. Write data to page buffer with 32-bit accesses at the needed address.
7. Perform page write (NVMCTRL.CTRLB).
8. Make sure NVM is ready to accept a new command (NVMCTRL.STATUS).
9. Clear the DONE Flag (NVMCTRL.INTFLAG).

**Note:** The Flash region where the page belongs must be unlocked in order to write it.

#### 27.5.6.3 Read While Write (RWW)

This feature makes it possible to program and read the NVM simultaneously without stalling the AHB bus independantly from any cache consideration. The basic principle is that NVM is made of two banks, one can be read while the other is programmed.

Limitations:

- It is not possible to read both banks simultaneously, reads will be prioritized and issued in series.
- It is not possible to program or erase both banks simultaneously, a new command will be accepted only after the completion of the previous one, otherwise the new command is ignored and INTFLAG.PROGE is set.
- RWW is not possible when reading or programming auxilliary pages, any read will result in an AHB stall and the command interface doesn't accept any command until completion of the previous one.

#### 27.5.6.4 Suspend/Resume

This feature can be enabled by writing a '1' to CTRLA.SUSPEN. Any modify operation, such as write or erase can be suspended even those triggered by the SmartEEPROM.

When enabled, the following commands are suspended by a NVM read request:

- EB

- WP

If a read occurs while executing one of the command listed above, the NVMCTRL will follow the following steps:

1. Send a suspend command to the NVM.
2. Wait for the NVM to be ready.
3. Read the NVM. The NVMCTRL will persist in this step when a new read request occurs, or else proceed.
4. Resume the suspended operation.

A suspend operation will set INTFLAG.SUSP. To clear it write a '1' to INTFLAG.SUSP.

The NVM suspended state is reflected in STATUS.SUSP.

Limitations:

- Suspend is not possible for a read in the page being programmed.
- Suspend is not possible for a read in a sector (128KB) containing a block under erase.
- It is not possible to enter power reduction mode when a command is suspended.

#### 27.5.6.5 Page Buffer

The page buffer is automatically cleared to *all-ones* after any page write operation (WP or WQW command). If a partial page has been written and it is desired to clear the contents of the page buffer, the Page Buffer Clear (PBC) command can be used. The status of the page buffer is given by STATUS.LOAD. This bit indicates that the NVM page buffer has been loaded with one or more words. Immediately after an NVM load has been performed, this flag is set, and it remains set until a WP or WQW or a PBC command is given.

The Page Buffer cannot be written while a write command is executing in the NVM. Trying to do so stalls the AHB bus. To avoid stalling the AHB bus, STATUS.READY can be polled prior to issue a write command.

Clearing the page buffer also clears to all ones the PBLDATA0 and PBLDATA1.

#### 27.5.6.6 Erase

Before a page can be written, it must be erased. The erase granularity depend on the address space (block or page). The Erase Block/Page command can be used to erase the desired block or page in the NVM main address space. Erasing the block/page sets all bits to '1'. If the block/page resides in a region that is locked, the erase will not be performed and the Lock Error bit in the INTFLAG register (INTFLAG.LOCKE) will be set. INTFLAG.PROGE will also be set since the command didn't complete. The Erase Page command can be issued on the USER page in the auxiliary space.

The procedure for an Erase Block/Page command is as follows:

- Write the address of the block/page to erase to ADDR. Any address within the block/page can be used.
- Issue an Erase Block/Page command.

The page buffer can be written while an erase page or erase block is being performed.

#### 27.5.6.7 Lock and Unlock Region

The commands LR and UR are used to lock and unlock regions. These commands only update the RUNLOCK register but not the corresponding field in the user page.

#### 27.5.6.8 Power Reduction Mode

The NVM implements a power reduction mode which cuts its static power consumption. If a command or a AHB access is issued the NVM is woken-up. The AHB access or the command are processed after the NVM wake-up time. The wake-up time can be reduced by enabling the PM fast wake-up feature, this is configured through the PM STDBYCFG register.

The NVM Power Reduction Mode is entered depending on the CTRLA.PRM mode:

- MANUAL:
  - Power Reduction Mode entering conditions:
    - SPRM command
  - Power Reduction Mode leaving conditions:
    - AHB access (read or write)
    - CPRM or any other command
- SEMIAUTO:
  - Power Reduction Mode entering conditions:
    - SPRM command
    - System enters standby mode
    - AHB access completes while in standby mode
    - Any command completes while in standby mode
  - Power Reduction Mode leaving conditions:
    - AHB access (read or write)
    - CPRM or any other command
- FULLAUTO:
  - Power Reduction Mode entering conditions:
    - SPRM command
    - System enters standby mode
    - AHB access completes while in standby mode
    - Any command completes while in standby mode
  - Power Reduction Mode leaving conditions:
    - AHB access (read or write)
    - CPRM or any other command
    - When the system leaves the standby mode

STATUS.READY is high when the NVM is in Power Reduction Mode indicating that the module can accept a command.

STATUS.PRM is high when the NVM is in Power Reduction Mode.

**Note:** It is not possible to enter power reduction mode when a command is suspended. Automatic power reduction entry is postponed until the command resumes and completes. The SPRM command is discarded when STATUS.SUSP is high and INTFLAG.PROGE is set.

### 27.5.7 Safe Flash Update Using Dual Banks

This feature enables a firmware to execute from the NVM and at the same time program the Flash with a new version of itself.

The new firmware has to be programmed in BANKB if STATUS.AFIRST=1, or BANKA otherwise.

After programming is completed one can issue the BKSWRST command to swap the banks and to reset the device. The information of which BANK is mapped to the NVM main address space base address is self contained in the NVM using a special fuse that can be programmed or erased individually. This fuse is managed by the BKSWRST command. STATUS.AFIRST reflects the status of this fuse after Reset. The BKSWRST command is atomic meaning that no fetch in the NVM can occur while executing this command. This command executes with the following steps:

1. Stall AHB interfaces.

2. If PARAM.SEE is '1' and  $0 < SEESTAT.SBLK < 11$ , the NVMCTRL starts to reallocate the SmartEEPROM data to the first bank. Active SEES remains the same at the end of the reallocation.
3. Is STATUS.AFIRST = 1: program the AFIRST fuse (new value = 0) otherwise erase it (new value = 1)
4. Resets the device, after reset, RSTC RCAUSE indicates that the reset was triggered by the NVMCTRL.

After Reset the new firmware is executed from the last programmed bank.

If the SmartEEPROM is configured, the size of the the reserved space in Flash must not exceed the bank size. In other words  $2 * SEESTAT.SBLK * 8192$  must be lower than half the NVM size in Bytes. In situations where both the banks contain separate applications (or an application in one bank and a bootloader in the other bank), both the banks must have Flash area reserved for SmartEEPROM. This means that the usable area for code in each bank is the *Size of the Bank*, minus the *size of the Flash* configured for the SmartEEPROM using SBLK Fuse.

## 27.5.8 SmartEEPROM

### 27.5.8.1 Principle of Operation

The SmartEEPROM feature is provided through the AHB2 interface and makes a portion of the NVM appear like a RAM. 8-bit, 16-bit, 32-bit access is supported.

The SmartEEPROM concept relies on the following NVM physical property: It is always possible to write a '0' in a NVM word, even if this word has been previously programmed - but it is not possible to write a '1' to a bit already programmed (holding a '0').

The algorithm consists of virtually mapping physical portions of the NVM to logical addresses with an indirection mechanism. A physical page is assigned to a virtual page address and is kept as long as no bit has to be flipped from '0' to '1', as this operation requires a full block erase. In case such a transition is required, a new physical page is assigned to the modified virtual page (placed in the Flash area reserved for the SmartEEPROM). Writing the virtual page affects the cycling endurance of the SmartEEPROM.

A region can overlap the SmartEEPROM region (depending on the allocated space for the SmartEEPROM), but SmartEEPROM is independent of the Region Lock Bits.

If NVMCTRL.STATUS.AFIRST contains '1', BANKA is mapped to the NVM main address space base address (0x0000). In this case, SmartEEPROM will be in BANKB. Conversely, when BANKB is mapped to the NVM main address space base address, SmartEEPROM will be in BANKA. Thus, the CPU is not halted when accessing the SmartEEPROM.

### 27.5.8.2 Address Spaces

The SmartEEPROM address space is divided in two distinct areas:

- DATA
  - Starts at offset 0x0
  - Size is 512B, 1KB, 2KB, 4KB, 8KB, 16KB, 32KB, 64KB depending on SEESTAT.PSZ and SEESTAT.SBLK (refer to "SmartEEPROM virtual size")
  - This area is write protected if SEESTAT.LOCK is set. SEESTAT.LOCK is non volatile.
  - Commands LSEE and USEE respectively lock and unlock the SmartEEPROM.
- REGISTER:
  - Starts at offset 0x10000
  - Size is 20B
  - This area is write protected if either
    - SEESTAT.LOCK is set (non-volatile)

- SEESTAT.RLOCK is set (volatile).

Commands LSEER and USEER respectively lock and unlock the SmartEEPROM register address space.

As a consequence both SEESTAT.LOCK and SEESTAT.RLOCK must be low to write the SmartEEPROM register address space.

### 27.5.8.3 Data Structures

The SmartEEPROM algorithm relies on two virtual sectors (SEES) physically located in the last blocks of:

- BANKB if STATUS.AFIRST=1
- BANKA if STATUS.AFIRST=0

Only one SEES is active at a time, the other must be erased, ready for data reallocation.

The current active SEES is indicated in SEESTAT.ASEES:

- 0: SEES0 is active
- 1: SEES1 is active

SEESTAT.ASEES is loaded after Reset from a special fuse in the NVM which can be programmed or erased individually. This fuse can be set by issuing the ASEES1 command or cleared by issuing the ASEES0 command. SEESTAT.ASEES reflects this change immediately.

The maximum number of virtual pages is limited to 128.

A page allocation consists of assigning a SEEP to a virtual page for the first time. A page reallocation consists of assigning a new SEEP to an already existing virtual page. In both cases the selected virtual page index and the next available page are written.

The SEEP size (PSZ) is configurable. The number of blocks allocated per SEES is configurable.

### 27.5.8.4 SmartEEPROM Virtual Size

The SmartEEPROM interface virtual size is the maximum amount of data that can be stored in it. This defines the maximum size of this interface. Trying to read or write outside the boundaries throws an hardfault exception.

The SBLK bits indicate the number of blocks allocated per SmartEEPROM virtual sector. The SmartEEPROM raw data resides in the upper blocks of the NVM main address space but is not accessible through AHB0 nor AHB1. The SmartEEPROM interface size depends on SEESTAT.PSZ and SEESTAT.SBLK:

**Table 27-6.** SmartEEPROM Virtual Size in Bytes

SmartEEPROM Virtual Size (Bytes)	(SEESTAT.SBLK, SEESTAT.PSZ) Valid Combination
512	(1,0)
1024	(1,1)
2048	(1,2)
4096	(1,3)
8192	(2,4)
16384	(3,5)
32768	(5,6)
65536	(10,7)

**Notes:**

1. If SEESTAT.SBLK = 0, no space is reserved for the SmartEEPROM.
2. All other values are reserved.



### 27.5.8.5 SmartEEPROM Wear Leveling

The wear leveling factor is the factor by which the frequency of total NVM erase block operations is divided when writing a new virtual page data compared to a "no wear leveling" system.

Refer to the [EEPROM Electrical Specifications](#) for more details.

### 27.5.8.6 Writing and Reading the SmartEEPROM

SEESTAT.LOCK must be '0'; otherwise, writes are discarded and a hardfault exception is thrown. SmartEEPROM write access can be locked with the LSEE command and unlocked with the USEE command.

1. Configure SBLK and PSZ fuses to define the SmartEEPROM total size and size of each page.
2. Define a pointer to the SmartEEPROM area. It can be used for 8, 16, or 32-bit access.

```
volatile uint8_t *SmartEEPROM8 = (uint8_t *) SEEPROM_ADDR;
volatile uint16_t *SmartEEPROM16 = (uint16_t *) SEEPROM_ADDR;
volatile uint32_t *SmartEEPROM32 = (uint32_t *) SEEPROM_ADDR;
```

3. Wait until SmartEEPROM is busy.

```
while (NVMCTRL->SEESTAT.bit.BUSY);
```

4. Write to the SmartEEPROM like writing a RAM location. Perform an 8, 16, or 32-bit write.
5. If automatic reallocation is disabled with SEECFG.APRDIS, check the SEESFULL interrupt flag to ensure that the active SmartEEPROM sector is not full.
6. To read back the content, read the location using the defined pointer.

```
uint8_t eep_data_8 = 0;
while (NVMCTRL->SEESTAT.bit.BUSY);
eep_data_8 = SmartEEPROM8[0];
```

WP command is triggered after any page buffer update.

INTFLAG.SEEWRC indicates when a AHB write to the SmartEEPROM has completed: NVM is programmed with correct values except if INTFLAG.SEESOVF was thrown.

### 27.5.8.7 SmartEEPROM Sector Reallocation

The SEES reallocation is performed by default in hardware when the next available page in the Host index reaches the maximum SEEP number. Automatic reallocation can be disabled by writing a one in SEECFG.APRDIS. The sector reallocation can also be triggered manually by issuing the SEERLOC command. The SEES reallocation process consists of: the following:

- Erase the non active sector.
- Copying the active sector valid data to the other sector, old data is filtered.
- Swap ASEES either by issuing the ASEES1 command if SEESTAT.ASEES is reading '0' or by issuing the ASEES0 command if SEESTAT.ASEES is read as '1'.

This process is by default automatically handled by hardware, and indicated by the SEESTAT.BUSY flag.

**Note:** The BKSWRST command triggers automatically the reallocation algorithm which operates as described above except copy is done in the same active sector but in the first bank. This operation is atomic, meaning that no modify operation can be issued in the mean time.

As the total size of the whole SEEP exceeds the SmartEEPROM virtual size for a given configuration there is always free SEEP to replace existing data. In the case all addresses have been written, after sector reallocation the number of free SEEP is 16.

### 27.5.9 NVM User Configuration

The NVM user configuration resides in the auxiliary space. Refer to the 'Physical Memory Map' and Product Mapping of the device for calibration and auxiliary space address mapping.

The NVM user configuration is:

- The boot loader size. The bootloader resides in the main array starting at offset zero. The allocated boot loader section is protected against erase or write operations including the chip erase operation.
- The SmartEEPROM number of blocks per SEES (SBLK bits). This configuration is loaded after a reset into SEESTAT.SBLK bits.
- The SmartEEPROM virtual page size (PSZ bits). This configuration is loaded after a reset into SEESTAT.PSZ bits.
- The region lock bits (reflected in the RUNLOCK register)
- The SmartEEPROM RUNLOCK bit (reflected in SEESTAT.LOCK)

**Table 27-7. Boot Loader Size**

BOOTPROT [3:0]	Rows Protected by BOOTPROT	Boot Loader Size in KBytes
15	None	0
14	1	8
13	2	16
12	3	24
11	4	32
10	5	40
9	6	48
8	7	56
7	8	64
6	9	72
5	10	80
4	11	88
3	12	96
2	13	104
1	14	112
0	15	120

**Table 27-8. SmartEEPROM Allocated Space in Flash**

SBLK[4:0]	Total Blocks	Bytes
10	20	163840
9 - 6	Reserved	Reserved
5	10	81920
4	Reserved	Reserved
3	6	49152
2	4	32768
1	2	16384
0	0	0

**Table 27-9. SmartEEPROM Virtual Page Size**

PSZ[2:0]	Page Size
7	512
6	256
5	128
4	64
3	32

.....continued

PSZ[2:0]	Page Size
2	16
1	8
0	4

### 27.5.10 Security Bit

The security bit allows the entire chip to be locked from external access for code security.

#### 27.5.10.1 Security Bit Set Procedure

1. Issue the Set Security Bit (SSB) command. If a debugger is connected, it still has access to the device after issuing this command (DSU STATUSB.PROT = 0).
2. Check NVMNCTRL.INTFLAG.PROGE and NVMNCTRL.INTFLAG.DONE.
3. Reset either the device or the NVMCTRL peripheral by issuing a SWRST command.
4. After reset, DSU STATUSB.PROT = 1.

#### 27.5.10.2 Security Bit Clear Procedure

The only way to clear the security bit is through a debugger Chip Erase command. The NVM security bit is cleared after all internal volatile and NVM have been cleared. The device protection status is updated at the end of the command meaning that no reset is necessary.

### 27.5.11 Line Cache

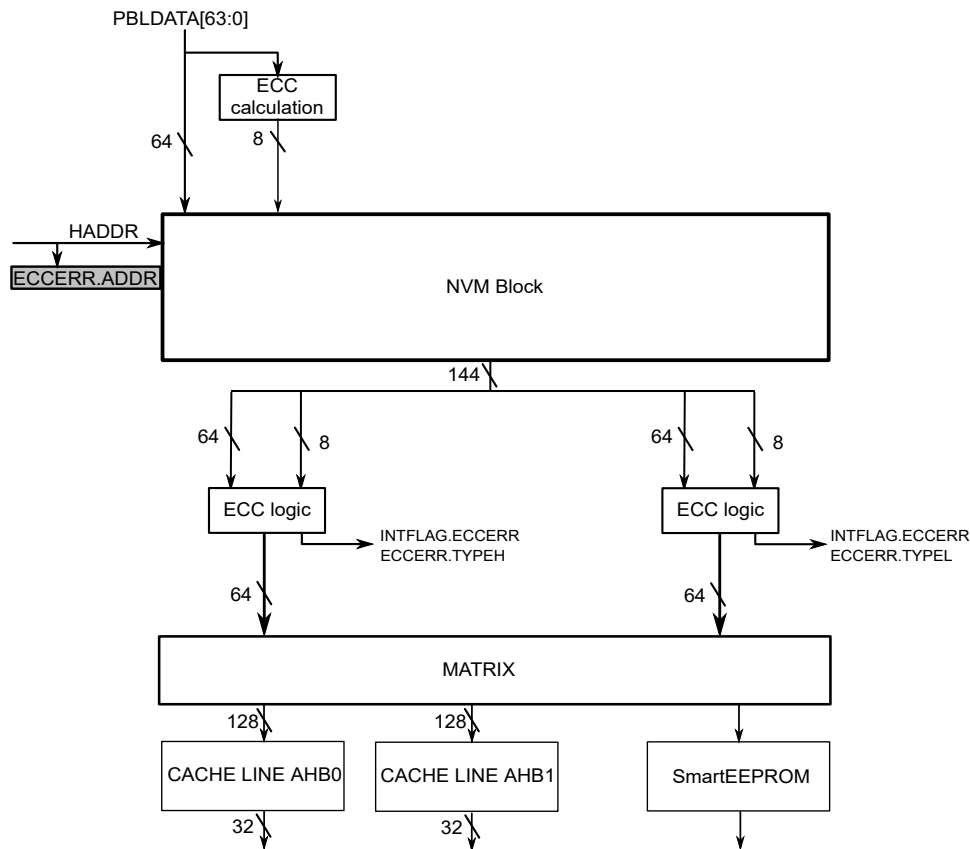
NVM reads 128-bit at a time. The AHB0 and AHB1 interfaces implement each a 128-bit cache line. This reduces the device power consumption when reading continuous data and improves system performance when wait states are required. Line cache are enabled by default and can be individually disabled per AHB interface by writing a one in the CACHEDIS[0] or CACHEDIS[1] bit in the CTRLA register (CTRLA.CACHEDIS[1:0]). Refer to the CTRLA register description for additional information. Commands affecting NVM content automatically invalidate cache lines.

### 27.5.12 Error Correction Code

Error Correcting Code (ECC) is implemented to detect and correct errors that may arise in the NVM array. ECC is enabled by default and cannot be disabled by the user.

### 27.5.12.1 Block Diagram

Figure 27-2. ECC Diagram



**Note:** The ECC correction is disabled when access is performed by the SmartEEPROM interface.

### 27.5.12.2 ECC Error Detection

The NVM physical block fetches 128-bit quad-word and ECC checking is performed on a 64-bit basis independently on the low and high double-words. Therefore two ECC decoders operate in parallel. An ECC failure may be present in any of the four words from the NVM, not necessarily the word that is addressed on the bus. Any ECC error in a double-word will be reported the first time the quad-word access. The ECC logic in the read data path is capable of double error detection and single error correction on the fly per 64-bit double-word.

Upon detection:

- INTFLAG ECC error flags are updated:
  - The ECC single error interrupt flag is raised (INTFLAG.ECCSE) in case of single error
  - The ECC dual error interrupt flag is raised (INTFLAG.ECCDE) in case of dual error
- ECCERR.ADDR is updated with the faulty quad-word byte address in the main address space.
- ECCERR.TYPEL is updated with the error type (NONE, SINGLE, DUAL) detected on the low 64-bit double word.
- ECCERR.TYPEH is updated with the error type (NONE, SINGLE, DUAL) detected on the high 64-bit double word.

INTFLAG.ECCSE and INTFLAG.ECCDE are automatically cleared when ECCERR is read.

ECCERR.TYPEL and ECCERR.TYPEH are reset to the NONE value when ECCERR is read. If an error occurs while reading ECCERR, the previous error information is sent to the APB and ECCERR is updated with the next error information.

If a single-error has been detected and INTFLAG.ECCSE or INTFLAG.ECCDE is not clear:

- Any incoming single-errors is ignored
- First incoming dual-error overrides ECCERR.ADDR, ECCERR.TYPEL and ECCERR.TYPEH

If a dual-error has been detected and INTFLAG.ECCDE is not clear:

- incoming single-errors are ignored
- incoming dual-errors are ignored

ECCERR.ADDR is always quad-word aligned. If jumping to a word that is not quad-word aligned, e.g. jumping to address 0x100C, INTFLAG.ECCDE and INTFLAG.ECCSE are updated according to the types of detected errors, and ECCERR.ADDR will read 0x1000, irrespective of whether the ECC error was in address 0x1000, 0x1004, 0x1008, or 0x100C.

### 27.5.13 Reset During Operation

Program or erase operations must not be interrupted. The content of a block or a page is unpredictable in case of reset during either an erase or a write operation. To reduce the risk of having a BOD reset due to a power loss one can monitor the external voltage before issuing any program or erase operation. The user can also prefer the WQW command instead of the WP command as a short command is more likely to complete successfully than a long one with a given external decoupling capacitor. In case of reset during a write or erase operation the impacted block must be erased before being read or programmed as its content is unknown.

### 27.5.14 Chip Erase

The chip erase operation is system-wide and issued through the DSU.

The chip erase procedure is as follows:

1. Volatile memories are cleared and NVM array is erased (except the auxiliary rows and the BOOTPROT section).
2. Special individual fuses are set:
  - If BOOTPROT section is not defined, then NVMCTRL.STATUS.AFIRST = 1 otherwise it is left unchanged
  - NVMCTRL.SEESTAT.ASEES = 1
  - NVMCTRL.SEESTAT.LOCK = 0
  - DSU.STATUSB.CELCK = 0
3. The Security bit is cleared provided no internal error has been detected in the previous steps:
  - If all internal NVM verify operations succeeded, go to Step 4.
  - Otherwise set DSU.STATUSA.DONE and DSU.STATUSA.FAIL, and then exit.
4. DSU.STATUSB.PROT is cleared, and the system is no more protected.

**Note:** The CB, FS, USER pages (in the auxiliary address space) and the BOOTPROT section are not affected by the chip-erase operation.

### 27.5.15 Chip Erase Hard Lock

It is possible to lock the DSU chip erase by issuing the Set Chip Erase Hard Lock command (SCEHL). After command execution, INTFLAG.DONE and DSU.STATUSB.CEHL are set.

This command can be issued only if DSU STATUSB.PROT = 1. The SCEHL command is discarded if the device is not protected (DSU STATUSB.PROT = 0) and INTFLAG.PROGE rises. This means that the firmware has to issue the command. Once programmed, the fuse cannot be erased.

External tools can know whether the chip erase hard lock feature is applied or not by reading the DSU STATUSB.CEHL as the DSU STATUSB register is always readable. A one indicates that the chip erase is locked.

If a DSU Chip-Erase command (DSU CTRL.CE = 1) is issued when DSU STATUSB.CEHL = 1, the command is discarded and both DSU STATUSA.DONE and DSU STATUSA.FAIL are set.

If the Security Bit and the CEHL fuse are set, the device is hard-locked, meaning the debug port and full chip erase are permanently disabled, hence the ability to modify the Flash with external accesses is inhibited.



Microchip's failure analysis capabilities are limited when this feature is used.

**Note:** If the device chip erase is hard-locked (DSU STATUSB.CEHL = 1), the execution of SCEHL/CELCK/CEULCK and SBPDIS/CBPDIS commands have no effect. The device remains locked and the Boot section security properties are not modified. The commands are discarded and INTFLAG.PROGE is set.

### 27.5.16 Boot Protect Hard Lock

Users can lock the boot section by issuing the Set Boot Protect Hard Lock command (SBPHL), and after command execution, INTFLAG.DONE and STATUSB.BPHL are set.

The command can be issued only if DSU STATUSB.PROT = 1. The SBPHL command is discarded if the device is not protected (DSU STATUSB.PROT = 0) and INTFLAG.PROGE rises. This means that it is the firmware has to issue the command. Once programmed, the fuse cannot be erased.

The boot section content and size cannot be modified with write or erase operations (WP, WQW, EP, and EB commands) when hard-locked, any attempt to write to an address inside the boot section will return an error and sets the INTFLAG.LOCKE bit. Also, any modify commands (write or erase) will be discarded and set both INTFLAG.PROGE and INTFLAG.LOCKE bits.

The controller also supports the option to protect a dual-boot section, if an over-the-air update is required. This is enabled by programming the DBPE fuse.

To enable the BPHL protection, follow these steps:

1. Clear the page buffer (PBC command in CTRLB register).
2. Load page buffer with the following 32-bit data, {27'b1, DBPE value to be programmed, BOOTPROT value to be programmed}, at an address with the following requirements:
  - a. The expected values must be written to the page offset 0x30. BOOTPROT value from the User Row (UROW) is ignored.
  - b. The address must be a writable location (R/W property). Any attempt to write a read-only location will trigger an error response, and page buffer will not be loaded with the new value.
3. If INTFLAG.LOCKE = 0, execute SBPHL command in the CTRLB register. The BPHL fuse is programmed if INTFLAG.NVME = 0. Else, INTFLAG.PROGE is set and the BPHL is not programmed.
4. Reset the device to refresh the STATUS.BOOTPROT and STATUS.DBPE bit fields.

When the SBPHL command is executed (before reset), the BOOTPROT value from the page buffer is programmed. BPHL fuse is then programmed and STATUS.BPHL = 1.

**Note:** BOOTPROT value from the User Row (UROW) is ignored, only the value programmed in the page buffer is.

After reset the STATUS.BOOTPROT and STATUS.DBPE bit fields reflect the value programmed during the SBPHL command execution. Once programmed, the BPHL fuse cannot be cleared, and the STATUS.BOOTPROT and STATUS.DBPE values cannot be changed if the Security bit is set.

It is recommended to check the programmed value in the STATUS register are the expected ones as they may not be recovered if the Set Chip Erase Hard Lock (SCEHL) command is executed.

- STATUS.BPHL = 1
- STATUS.BOOTPROT = expected BOOTPROT value programmed in the page buffer
- STATUS.DBPE = expected DBPE value programmed in the page buffer

Execution of the SBPHL command is not allowed when the device is not protected (DSU STATUSB.PROT = 0). The command is discarded and INTFLAG.PROGE is set.

Execution of SBPDIS and CBPDIS commands is not allowed when the STATUS.BPHL bit and the DSU STATUSB.PROT bit are set. The commands are discarded and INTFLAG.PROGE is set.

Follow these procedure to configure and lock the boot sections:

1. Program the boot section.
2. Secure the part by issuing the Set Security bit command.
3. Reset the device.
4. Enable BPHL protection (see above).
5. Optionally check whether the boot protection is effective (see above).
6. Optionally issue the Set Chip Erase Hard Lock (SCEHL) command.
7. Reset the device.

After each NVM command execution, the INTFLAG.PROGE must be checked.

The boot loader section size and content are now permanently locked.

**Notes:**

1. If the SCEHL command is not issued, the security fuse bit can still be erased by executing the chip erase command. It is therefore recommended to apply the SCEHL command after the SBPHL command.
2. The SBPHL command execution is allowed even if the boot size is zero (BOOTPROT[3:0] = 0xF).
3. When the security bit is cleared (DSU STATUSB.PROT = 0), the boot section can be updated if the SBPDIS command is executed.

The Smart EEPROM section is not allowed to overlap the boot sections. It is recommended to check SEESTAT.SMEECERR bit status after reset.

**Note:** In the case of dual ECC error, the fuse update mechanism is aborted. The firmware must check if the STATUS.BOOTPROT setting has the expected value, and the INTFLAG.ECCDE is not set. If one of these conditions is not met, the firmware must decide the most appropriate conditions to be applied. A device reset or placing the device in a lock-up state are the available options.

**27.5.16.1 Dual-Boot Protection Enable**

For applications where the bank swapping is a requirement, the device offers the option to implement a dual-boot protection mechanism, to avoid alternate boot section modifications with write or erase operations. This feature is available only when the boot protect hard lock mode is enabled.

The dual-boot protection is programmed when executing the SBPHL command. After reset, the fuse value is stored in the STATUS.DBPE bit.

If STATUS.DBPE = 0, swapping a bank is not possible. An alternate boot area is not relevant, hence the main array is contiguous. The execution of the BKSWRST command is discarded and INTFLAG.PROGE is set.

**Table 27-10.** Bank Swap Operation

STATUS.BPHL	STATUS.DBPE	Bank Swap Operation
0	0	Allowed
0	1	N/A
1	0	Not allowed
1	1	Allowed

### 27.5.17 Boot Read Protection

The boot read protection is enabled by setting the BRPE bit in the BCTRL register. If the BRPE bit is set, the primary boot array is not readable, except the last 32-words (128-bytes), and are execute-only. This means this section is reserved to set the BRPE bit and jump to the main array.

The firmware must set this bit. If the dual-boot protection is enabled, the alternate boot is read-protected (no execute-only area).

When set, only a start-up reset will clear the boot read protection. The software reset command has no effect.

**Note:** Boot read protection is independent from boot protect hard lock.

### 27.5.18 Immutable Boot, Boot Read Protection, and Secure Debug Features Overview

The following tables provide an overview of the major security options.

**Table 27-11.** Immutable Boot Capability <sup>(1)</sup>

Chip Erase Hard Lock (DSU STATUSB.CEHL)	Boot Protect Hard Lock (NVMCTRL STATUS.BPHL)	Immutable Boot Capability
X	0	No
X	1	Yes

**Note:**

1. The Immutable Boot feature optionally coupled with Chip Erase Hard Lock and Boot Read Protection allows for the support of a Secure Boot flow in the condition where a specific application code is developed and programmed on the boot section.

**Table 27-12.** Boot Code Update Capability

Security Bit (DSU STATUSB.PROT)	Boot Protect Hard Lock (NVMCTRL STATUS.BPHL)	Boot Protect Disable (NVMCTRL STATUS.BPDIS)	Boot Code Update Capability
1	1	X	No
1	0	X	Yes <sup>(1)</sup>
0	N/A	0	Yes <sup>(1)</sup>
0	N/A	1	Yes

**Note:**

1. Requires to perform a Boot Protect Disable command (SBPDIS).



**Table 27-13.** Re-Flash Device Capability<sup>(1)</sup>

Chip Erase Hard Lock (DSU STATUSB.CEHL)	Boot Protect Hard Lock (NVMCTRL STATUS.BPHL)	Re-Flash Device
0	0	Yes
0	1	Yes (except BOOTPROT region)
1	X	No

**Note:**

1. The Re-Flash of the device is the ability to perform a chip erase and re-program the Flash. Performing a chip erase allows to clear the security bit (if set) and so re-enable debug capabilities.

## 27.6 Register Summary

Offset	Name	Bit Pos.	7	6	5	4	3	2	1	0
0x00	CTRLA	7:0	PRM[1:0]		WMODE[1:0]		SUSPEN	AUTOWS		
		15:8	CACHEDIS1	CACHEDIS0	AHBNS1	AHBNS0	RWS[3:0]			
0x02 ... 0x03	Reserved									
0x04	CTRLB	7:0	CMD[6:0]							
		15:8	CMDEX[7:0]							
0x06 ... 0x07	Reserved									
0x08	PARAM	7:0	NVMP[7:0]							
		15:8	NVMP[15:8]							
		23:16	PSZ[2:0]							
		31:24	SEE							
0x0C	INTENCLR	7:0	SUSP	NVME	ECCDE	ECCSE	LOCKE	PROGE	ADDRE	DONE
		15:8						SEEWRC	SEESOVF	SEESFULL
0x0E	INTENSET	7:0	SUSP	NVME	ECCDE	ECCSE	LOCKE	PROGE	ADDRE	DONE
		15:8						SEEWRC	SEESOVF	SEESFULL
0x10	INTFLAG	7:0	SUSP	NVME	ECCDE	ECCSE	LOCKE	PROGE	ADDRE	DONE
		15:8						SEEWRC	SEESOVF	SEESFULL
0x12	STATUS	7:0			BPDIS	AFIRST	SUSP	LOAD	PRM	READY
		15:8			BPHL	DBPE	BOOTPROT[3:0]			
0x14	ADDR	7:0	ADDR[7:0]							
		15:8	ADDR[15:8]							
		23:16	ADDR[23:16]							
		31:24								
0x18	RUNLOCK	7:0	RUNLOCK[7:0]							
		15:8	RUNLOCK[15:8]							
		23:16	RUNLOCK[23:16]							
		31:24	RUNLOCK[31:24]							
0x1C	PBLDATA0	7:0	DATA[7:0]							
		15:8	DATA[15:8]							
		23:16	DATA[23:16]							
		31:24	DATA[31:24]							
0x20	PBLDATA1	7:0	DATA[7:0]							
		15:8	DATA[15:8]							
		23:16	DATA[23:16]							
		31:24	DATA[31:24]							
0x24	ECCERR	7:0	ADDR[7:0]							
		15:8	ADDR[15:8]							
		23:16	ADDR[23:16]							
		31:24	TYPEH[1:0]		TYPEL[1:0]					
0x28	DBGCTRL	7:0						ECCELOG	ECCDIS	
0x29	BCTRL	7:0							BRPE	
0x2A	SEECFG	7:0						APRDIS	WMODE	
0x2B	Reserved									
0x2C	SEESTAT	7:0				RLOCK	LOCK	BUSY	Reserved	ASEES
		15:8						SBLK[3:0]		
		23:16						PSZ[2:0]		
		31:24								

## 27.6.1 Control A

**Name:** CTRLA  
**Offset:** 0x0  
**Reset:** 0x0004  
**Property:** PAC Write-Protection

Bit	15	14	13	12	11	10	9	8
	CACHEDIS1	CACHEDIS0	AHBNS1	AHBNS0	RWS[3:0]			
Access	R/W	R/W	R/W	R/W	R/W	R/W	R/W	R/W
Reset	0	0	0	0	0	0	0	0
Bit	7	6	5	4	3	2	1	0
	PRM[1:0]		WMODE[1:0]		SUSPEN	AUTOWS		
Access	R/W	R/W	R/W	R/W	R/W	R/W		
Reset	0	0	0	0	0	1		

**Bit 15 - CACHEDIS1** AHB1 Cache Disable  
AHB1 interface cache disable.  
0: cache line is enabled  
1: cache line is disabled  
Cache lines are automatically invalidated when a write or erase operation is started in the NVM.

**Bit 14 - CACHEDIS0** AHB0 Cache Disable  
AHB0 interface cache disable.  
0: cache line is enabled  
1: cache line is disabled  
Cache lines are automatically invalidated when a write or erase operation is started in the NVM.

**Bit 13 - AHBNS1** Force AHB1 access to Non-Sequential  
This bit forces AHB1 communication to be non-sequential.

Value	Description
0	AHB sequential accesses remain sequential.
1	AHB sequential accesses are forced to non-sequential, therefore forcing re arbitration for each access.

**Bit 12 - AHBNS0** Force AHB0 access to Non-Sequential  
This bit forces AHB0 communication to be non-sequential.

Value	Description
0	AHB sequential accesses remain sequential.
1	AHB sequential accesses are forced to non-sequential, therefore forcing re arbitration for each access.

**Bits 11:8 - RWS[3:0]** NVM Read Wait States  
These bits give the number of wait states for a read operation when AUTOWS=0. Zero indicates zero wait states, one indicates one wait state, etc., up to 15 wait states.  
This register is initialized to 0 wait states. Software can change this value based on the NVM access time and system frequency.

**Bits 7:6 - PRM[1:0]** Power Reduction Mode during Sleep  
Indicates the power reduction mode during sleep.

Value	Name	Description
0x0	SEMIAUTO	NVM block enters low-power mode when entering standby mode. NVM block enters low-power mode when SPRM command is issued. NVM block exits low-power mode upon first access.
0x1	FULLAUTO	NVM block enters low-power mode when entering standby mode. NVM block enters low-power mode when SPRM command is issued. NVM block exits low-power mode when system is not in standby mode.

Value	Name	Description
0x2		Reserved
0x3	MANUAL	NVM block does not enter low-power mode when entering standby mode. NVM block enters low-power mode when SPRM command is issued. NVM block exits low-power mode upon first access.

**Bits 5:4 – WMODE[1:0] Write Mode**

Write commands can be generated automatically when crossing address boundaries while writing to the NVM. Boundaries depend on the settings below.

Value	Name	Description
0x0	MAN	Manual Write
0x1	ADW	Automatic Double Word Write
0x2	AQW	Automatic Quad Word
0x3	AP	Automatic Page Write

**Bit 3 – SUSPEN Suspend Enable**

0: The write and erase suspend resume feature is disabled.

1: A write or erase operation can be suspended in case of a read in the same bank.

**Bit 2 – AUTOWS Auto Wait State Enable**

0: Automatic wait state generation is disabled. The number of wait states used is given by CTRLA.RWS bits.

1: Automatic wait state generation is enabled. The number of wait states used is automatically detected therefore the module can operate at any frequency up to the device maximum frequency. A minimum of one cycle latency is induced.

## 27.6.2 Control B

**Name:** CTRLB  
**Offset:** 0x04  
**Reset:** 0x0000  
**Property:** PAC Write-Protection

Bit	15	14	13	12	11	10	9	8
	CMDEX[7:0]							
Access	PAC Write- Protection	PAC Write- Protection	PAC Write- Protection	PAC Write- Protection	PAC Write- Protection	PAC Write- Protection	PAC Write- Protection	PAC Write- Protection
Reset	0	0	0	0	0	0	0	0
Bit	7	6	5	4	3	2	1	0
		CMD[6:0]						
Access		W	W	W	W	W	W	W
Reset		0	0	0	0	0	0	0

### Bits 15:8 – CMDEX[7:0] Command Execution

This bit group should be written with the key value 0xA5 to enable the command written to CMD to be executed. If the bit group is written with a different key value, the write is not performed and INTFLAG.PROGE is set. PROGE is also set if the a previously written command is not complete. The key value must be written at the same time as CMD. If a command is issued through the APB bus on the same cycle as an AHB bus access, the AHB bus access will be given priority. The command will then be executed when the NVM block and the AHB bus are idle. STATUS.READY must be one when the command is issued. INTFLAG.DONE is set when the command completes.

Value	Name	Description
0xA5	KEY	Execution Key
Other	-	Reserved

### Bits 6:0 – CMD[6:0] Command

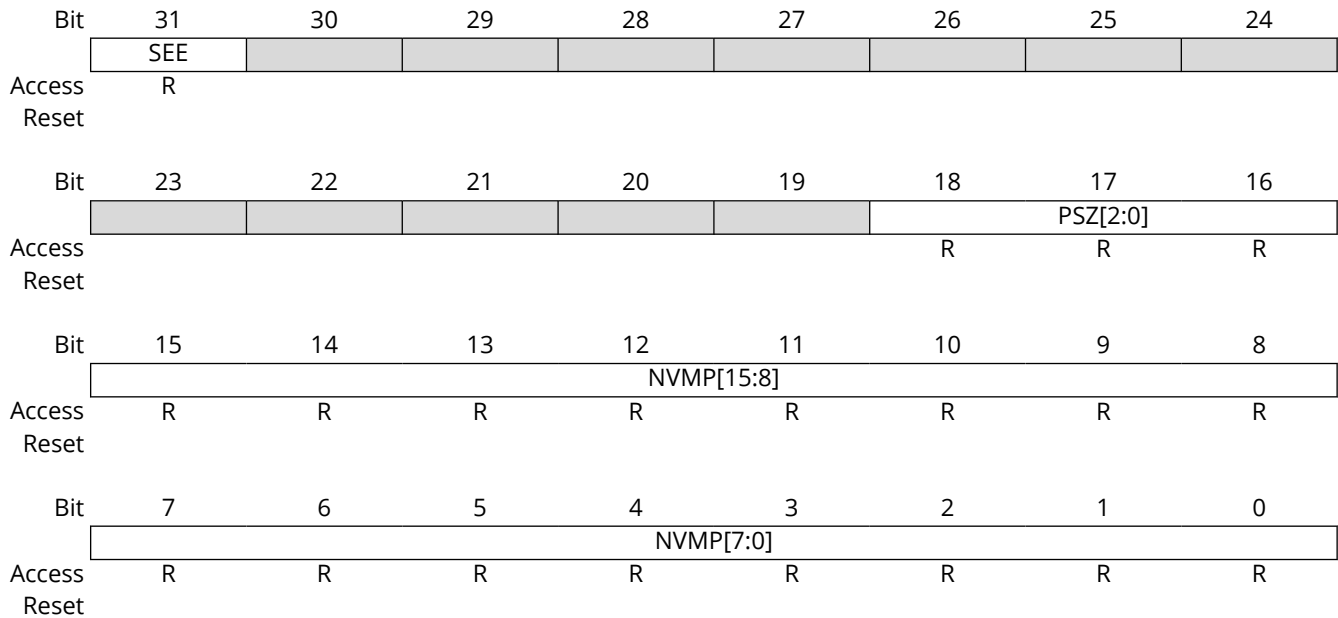
These bits define the command to be executed when the CMDEX key is written.

Value	Name	Description
0x0	EP	Erase Page - Only supported in the User page in the auxiliary space.
0x1	EB	Erase Block - Erases the block addressed by the ADDR register, not supported in the user page
0x2		Reserved
0x3	WP	Write Page - Writes the contents of the page buffer to the page addressed by the ADDR register, not supported in the user page
0x4	WQW	Write Quad Word - Writes a 128-bit word at the location addressed by the ADDR register.
0x5-0xF		Reserved
0x10	SWRST	Software Reset - Power-Cycle the NVM memory and repeat the device automatic calibration procedure and resets the module configuration registers
0x11	LR	Lock Region - Locks the region containing the address location in the ADDR register until next reset.
0x12	UR	Unlock Region - Unlocks the region containing the address location in the ADDR register until next reset.
0x13	SPRM	Sets the power reduction mode.
0x14	CPRM	Clears the power reduction mode.
0x15	PBC	Page Buffer Clear - Clears the page buffer.
0x16	SSB	Set Security Bit
0x17	BKSWRST	Bank swap and system reset, if SmartEEPROM is used also reallocate its data into the opposite BANK

Value	Name	Description
0x18	CELCK	Chip Erase Lock - DSU CTRL.CE command is not available. As soon as the CELCK command is successfully executed, the chip erase capability is disabled and Microchip's failure analysis capabilities are limited. Therefore, the software has to ensure there is a way to unlock the chip erase by executing the CEULCK command.
0x19	CEULCK	Chip Erase Unlock - DSU CTRL.CE command is available
0x1A	SBPDIS	Sets STATUS.BPDIS, Boot loader protection is discarded until CBPDIS is issued or next start-up sequence
0x1B	CBPDIS	Clears STATUS.BPDIS, Boot loader protection is not discarded
0x1C	SCEHL	Set Chip Erase Hard Lock - DSU CTRL.CE command is not available.
0x1D	SBPHL	Set Boot Protect Hard Lock
0x1E - 0x2F	-	Reserved
0x30	ASEES0	Configure SmartEEPROM to use Sector 0
0x31	ASEES1	Configure SmartEEPROM to use Sector 1
0x32	SEERALOC	Starts SmartEEPROM sector reallocation algorithm
0x33	-	Reserved
0x34	LSEE	Lock access to SmartEEPROM data from any means
0x35	USEE	Unlock access to SmartEEPROM data
0x36	LSEER	Lock access to the SmartEEPROM Register Address Space (above 64KB)
0x37	USEER	Unlock access to the SmartEEPROM Register Address Space (above 64KB)
0x38-0x7F	-	Reserved

### 27.6.3 NVM Parameter

**Name:** PARAM  
**Offset:** 0x08  
**Property:** -



**Bit 31 – SEE** SmartEEPROM Supported  
0: No SmartEEPROM support  
1: SmartEEPROM is supported.

**Bits 18:16 – PSZ[2:0]** Page Size  
Indicates the page size. Not all device families will provide all the page sizes indicated in the table.

Value	Name	Description
0x0–0x5	Reserved	Reserved
0x6	512	512 bytes
0x7	Reserved	Reserved

**Bits 15:0 – NVMP[15:0]** NVM Pages  
Indicates the number of pages in the NVM main address space

## 27.6.4 Interrupt Enable Clear

**Name:** INTENCLR  
**Offset:** 0x0C  
**Reset:** 0x0000  
**Property:** PAC Write-Protection

Bit	15	14	13	12	11	10	9	8
						SEEWRC	SEESOVF	SEESFULL
Access						R/W	R/W	R/W
Reset						0	0	0
Bit	7	6	5	4	3	2	1	0
	SUSP	NVME	ECCDE	ECCSE	LOCKE	PROGE	ADDRE	DONE
Access	R/W	R/W	R/W	R/W	R/W	R/W	R/W	R/W
Reset	0	0	0	0	0	0	0	0

### Bit 10 – SEEWRC SEE Write Completed Interrupt Clear

Writing a zero to this bit has no effect.  
 Writing a '1' to this bit clears the SEEWRC interrupt enable.  
 This bit will read as the current value of the SEEWRC interrupt enable.

### Bit 9 – SEESOVF Active SEES Overflow Interrupt Clear

Writing a zero to this bit has no effect.  
 Writing a '1' to this bit clears the SEESOVF interrupt enable.  
 This bit will read as the current value of the SEESOVF interrupt enable.

### Bit 8 – SEESFULL Active SEES Full Interrupt Clear

Writing a zero to this bit has no effect.  
 Writing a '1' to this bit clears the SEESFULL interrupt enable.  
 This bit will read as the current value of the SEESFULL interrupt enable.

### Bit 7 – SUSP Suspended Write Or Erase Interrupt Clear

Writing a zero to this bit has no effect.  
 Writing a '1' to this bit clears the SUSP interrupt enable.  
 This bit will read as the current value of the SUSP interrupt enable.

### Bit 6 – NVME NVM Error Interrupt Clear

Writing a zero to this bit has no effect.  
 Writing a '1' to this bit clears the NVME interrupt enable.  
 This bit will read as the current value of the NVME interrupt enable.

### Bit 5 – ECCDE ECC Dual Error Interrupt Clear

Writing a zero to this bit has no effect.  
 Writing a '1' to this bit clears the ECCDE interrupt enable.  
 This bit will read as the current value of the ECCDE interrupt enable.

### Bit 4 – ECCSE ECC Single Error Interrupt Clear

Writing a zero to this bit has no effect.  
 Writing a '1' to this bit clears the ECCSE interrupt enable.  
 This bit will read as the current value of the ECCSE interrupt enable.

### Bit 3 – LOCKE Lock Error Interrupt Clear

Writing a zero to this bit has no effect.



Writing a '1' to this bit clears the LOCKE interrupt enable.  
This bit will read as the current value of the LOCKE interrupt enable.

**Bit 2 – PROGE** Programming Error Interrupt Clear

Writing a zero to this bit has no effect.  
Writing a '1' to this bit clears the PROGE interrupt enable.  
This bit will read as the current value of the PROGE interrupt enable.

**Bit 1 – ADDRE** Address Error Interrupt Clear

Writing a zero to this bit has no effect.  
Writing a '1' to this bit clears the ADDRE interrupt enable.  
This bit will read as the current value of the ADDRE interrupt enable.

**Bit 0 – DONE** Command Done Interrupt Clear

Writing a zero to this bit has no effect.  
Writing a '1' to this bit clears the DONE interrupt enable.  
This bit will read as the current value of the DONE interrupt enable.

## 27.6.5 Interrupt Enable Set

**Name:** INTENSET  
**Offset:** 0x0E  
**Reset:** 0x0000  
**Property:** PAC Write-Protection

Bit	15	14	13	12	11	10	9	8
						SEEWRC	SEESOVF	SEESFULL
Access						R/W	R/W	R/W
Reset						0	0	0
Bit	7	6	5	4	3	2	1	0
	SUSP	NVME	ECCDE	ECCSE	LOCKE	PROGE	ADDRE	DONE
Access	R/W	R/W	R/W	R/W	R/W	R/W	R/W	R/W
Reset	0	0	0	0	0	0	0	0

**Bit 10 – SEEWRC** SEE Write Completed Interrupt Enable  
 Writing a zero to this bit has no effect.  
 Writing a one to this bit sets the SEEWRC interrupt enable.  
 This bit will read as the current value of the SEEWRC interrupt enable.

**Bit 9 – SEESOVF** Active SEES Overflow Interrupt Enable  
 Writing a zero to this bit has no effect.  
 Writing a one to this bit sets the SEESOVF interrupt enable.  
 This bit will read as the current value of the SEESOVF interrupt enable.

**Bit 8 – SEESFULL** Active SEES Full Interrupt Enable  
 Writing a zero to this bit has no effect.  
 Writing a one to this bit sets the SEESFULL interrupt enable.  
 This bit will read as the current value of the SEESFULL interrupt enable.

**Bit 7 – SUSP** Suspended Write Or Erase Interrupt Enable  
 Writing a zero to this bit has no effect.  
 Writing a one to this bit sets the SUSP interrupt enable.  
 This bit will read as the current value of the SUSP interrupt enable.

**Bit 6 – NVME** NVM Error Interrupt Enable  
 Writing a zero to this bit has no effect.  
 Writing a one to this bit sets the NVME interrupt enable.  
 This bit will read as the current value of the NVME interrupt enable.

**Bit 5 – ECCDE** ECC Dual Error Interrupt Enable  
 Writing a zero to this bit has no effect.  
 Writing a one to this bit sets the ECCDE interrupt enable.  
 This bit will read as the current value of the ECCDE interrupt enable.

**Bit 4 – ECCSE** ECC Single Error Interrupt Enable  
 Writing a zero to this bit has no effect.  
 Writing a one to this bit sets the ECCSE interrupt enable.  
 This bit will read as the current value of the ECCSE interrupt enable.

**Bit 3 – LOCKE** Lock Error Interrupt Enable  
 Writing a zero to this bit has no effect.

Writing a one to this bit sets the LOCKE interrupt enable.  
This bit will read as the current value of the LOCKE interrupt enable.

**Bit 2 – PROGE** Programming Error Interrupt Enable

Writing a zero to this bit has no effect.  
Writing a one to this bit sets the PROGE interrupt enable.  
This bit will read as the current value of the PROGE interrupt enable.

**Bit 1 – ADDRE** Address Error Interrupt Enable

Writing a zero to this bit has no effect.  
Writing a one to this bit sets the ADDRE interrupt enable.  
This bit will read as the current value of the ADDRE interrupt enable.

**Bit 0 – DONE** Command Done Interrupt Enable

Writing a zero to this bit has no effect.  
Writing a one to this bit sets the DONE interrupt enable.  
This bit will read as the current value of the DONE interrupt enable.

## 27.6.6 Interrupt Flag Status and Clear

**Name:** INTFLAG  
**Offset:** 0x10  
**Reset:** 0x0000  
**Property:** -

Bit	15	14	13	12	11	10	9	8
						SEEWRC	SEESOVF	SEESFULL
Access						R/W	R/W	R/W
Reset						0	0	0

Bit	7	6	5	4	3	2	1	0
	SUSP	NVME	ECCDE	ECCSE	LOCKE	PROGE	ADDRE	DONE
Access	R/W	R/W	R	R	R/W	R/W	R/W	R/W
Reset	0	0	0	0	0	0	0	0

### Bit 10 – SEEWRC SEE Write Completed

0: AHB write is pending.  
1: AHB write has completed, and NVM is programmed with correct values.

### Bit 9 – SEESOVF Active SEES Overflow

0: No SEES overflow have been detected since the last clear.  
1: At least SEES overflow has been detected since the last clear.  
This bit can be cleared by writing a one to its bit location.

### Bit 8 – SEESFULL Active SEES Full

0: The active SEES is not full  
1: The active SEES is Full, meaning that the next write will fail if the active sector is not reallocated.  
This bit can be cleared by writing a one to its bit location.

### Bit 7 – SUSP Suspended Write Or Erase Operation

0: No write/suspend has occurred since the last clear.  
1: A write or erase operation has been suspended since the last clear.  
This bit can be cleared by writing a one to its bit location.

### Bit 6 – NVME NVM Error

0: No NVM errors have been received since the last clear.  
1: At least one NVM error has occurred since the last clear.  
This bit can be cleared by writing a one to its bit location.

### Bit 5 – ECCDE ECC Dual Error

0: No ECC dual errors have been received since the last ECCERR register read.  
1: At least one ECC error has occurred since the last ECCERR register read.  
This bit is cleared when the ECCERR register is read.

### Bit 4 – ECCSE ECC Single Error

0: No ECC single errors have been received since the last ECCERR register read.  
1: At least one ECC error has occurred since the last ECCERR register read.  
This bit is cleared when the ECCERR register is read.

### Bit 3 – LOCKE Lock Error

0: No LOCK errors have been received since the last clear.  
1: At least one LOCK error has occurred since the last clear.

This bit can be cleared by writing a one to its bit location.

**Bit 2 – PROGE** Programming Error

0: No PROG errors have been received since the last clear.

1: At least one PROG error has occurred since the last clear.

This bit can be cleared by writing a one to its bit location.

**Bit 1 – ADDRE** Address Error

0: No ADDRE error has been detected since the last clear.

1: At least one ADDRE error has been detected since the last clear.

This bit can be cleared by writing a one to its bit location.

**Bit 0 – DONE** Command Done

0: The NVM controller has not completed any command since the last clear.

1: At least one command has completed since the last clear.

This bit can be cleared by writing a one to its bit location.

## 27.6.7 Status

**Name:** STATUS  
**Offset:** 0x12  
**Reset:** 0x0000  
**Property:** Read-Only

Bit	15	14	13	12	11	10	9	8
			BPHL	DBPE	BOOTPROT[3:0]			
Access			R	R	R	R	R	R
Reset			0	0	0	0	0	x
Bit	7	6	5	4	3	2	1	0
			BPDIS	AFIRST	SUSP	LOAD	PRM	READY
Access			R	R	R	R	R	R
Reset			0	1	0	0	0	0

### Bit 13 – BPHL Boot Protect Hard Lock

This bit is loaded 1 when the BPHL fuse is programmed (SBPHL command is executed successfully).

### Bit 12 – DBPE Dual Boot Protection Enable

If the BPHL fuse is programmed, the bit is loaded with the DBPE value programmed during the BPHL protection sequence.

If the BPHL fuse is erased, this bit is always read zero.

When set, BOOTSIZE from each BANK A and BANK B are protected against modification (write, erase).

When erased, BOOTSIZE from 0x0000\_0000 is protected against modifications (write or erase).

When the security bit is cleared, the DBPE bit is read zero.

### Bits 11:8 – BOOTPROT[3:0] Boot Loader Protection Size

Defines the size of the BOOTPROT region which is protected against write or erase or Chip-Erase operations. This size is given by the following formula  $(15-BOOTPROT)*8KB$ .

When the BPHL bit is cleared, this bitfield is loaded from fuse bits located in the User row (UROW), during the device startup.

When the BPHL bit is set, this bitfield is loaded from the BOOTPROT programmed value during the BPHL protection sequence, and reflects the BOOTPROT value from the User Row, when the Set Boot Protect Hard Lock command was issued.

### Bit 5 – BPDIS Boot Loader Protection Disable

0: Boot loader protection is not discarded.

1: Boot loader protection against modify operations is discarded until CBPDIS is issued or next start-up sequence except for Chip-Erase.

**Note:** If the STATUS.BPHL=1, the BPDIS setting is ignored and the boot loader protection is always enabled.

### Bit 4 – AFIRST BANKA First

0: Start address of bank B is mapped at 0x0000\_0000.

1: Start address of bank A is mapped at 0x0000\_0000.

### Bit 3 – SUSP NVM Write Or Erase Operation Is Suspended

0: The NVM controller is not in suspended state.

1: The NVM controller is in suspended state.

**Bit 2 – LOAD** NVM Page Buffer Active Loading

This bit indicates that the NVM page buffer has been loaded with one or more words. Immediately after an NVM load has been performed, this flag is set, and it remains set until a Write Page (WP), Write Quad Word (WQW) or a page buffer clear (PBCLR) command is given.

**Bit 1 – PRM** Power Reduction Mode

This bit indicates the current NVM power reduction state. The NVM block can be set in power reduction mode in two ways: through the command interface or automatically when entering sleep with CTRLA.PRM set accordingly. PRM can be cleared in three ways: through AHB access to the NVM block, through the command interface (SPRM and CPRM) or when exiting sleep with CTRLA.PRM set accordingly.

0: NVM is not in power reduction mode

1: NVM is in power reduction mode.

**Bit 0 – READY** Ready to accept a command

0: The NVM controller is busy programming or erasing.

1: The NVM controller is ready to accept a new command.

## 27.6.8 Address

**Name:** ADDR  
**Offset:** 0x14  
**Reset:** 0x00000000  
**Property:** PAC Write-Protection

Bit	31	30	29	28	27	26	25	24
Access								
Reset								
Bit	23	22	21	20	19	18	17	16
	ADDR[23:16]							
Access	R/W	R/W	R/W	R/W	R/W	R/W	R/W	R/W
Reset	0	0	0	0	0	0	0	0
Bit	15	14	13	12	11	10	9	8
	ADDR[15:8]							
Access	R/W	R/W	R/W	R/W	R/W	R/W	R/W	R/W
Reset	0	0	0	0	0	0	0	0
Bit	7	6	5	4	3	2	1	0
	ADDR[7:0]							
Access	R/W	R/W	R/W	R/W	R/W	R/W	R/W	R/W
Reset	0	0	0	0	0	0	0	0

### Bits 23:0 – ADDR[23:0] NVM Address

ADDR drives the hardware address to the NVM when a command is executed using CMDEX. It is a Byte address. This register is also automatically updated when writing to the page buffer or when writing the SmartEEPROM.



## 27.6.9 Lock Section

**Name:** RUNLOCK  
**Offset:** 0x18  
**Reset:** 0xFFFFFFFF  
**Property:** -

Bit	31	30	29	28	27	26	25	24
	RUNLOCK[31:24]							
Access	R	R	R	R	R	R	R	R
Reset	x	x	x	x	x	x	x	x
Bit	23	22	21	20	19	18	17	16
	RUNLOCK[23:16]							
Access	R	R	R	R	R	R	R	R
Reset	x	x	x	x	x	x	x	x
Bit	15	14	13	12	11	10	9	8
	RUNLOCK[15:8]							
Access	R	R	R	R	R	R	R	R
Reset	x	x	x	x	x	x	x	x
Bit	7	6	5	4	3	2	1	0
	RUNLOCK[7:0]							
Access	R	R	R	R	R	R	R	R
Reset	x	x	x	x	x	x	x	x

### Bits 31:0 – RUNLOCK[31:0] Region Un-Lock Bits

In order to set or clear these bits, the CMD register must be used to execute Lock Region and Unlock Region commands.

0: The corresponding region is locked.

1: The corresponding region is not locked.

### 27.6.10 Page Buffer Load Data x

**Name:** PBLDATAx  
**Offset:** 0x1C + x\*0x04 [x=0..1]  
**Reset:** 0xFFFFFFFF  
**Property:** -

Bit	31	30	29	28	27	26	25	24
	DATA[31:24]							
Access	R	R	R	R	R	R	R	R
Reset	0	0	0	0	0	0	0	0
Bit	23	22	21	20	19	18	17	16
	DATA[23:16]							
Access	R	R	R	R	R	R	R	R
Reset	0	0	0	0	0	0	0	0
Bit	15	14	13	12	11	10	9	8
	DATA[15:8]							
Access	R	R	R	R	R	R	R	R
Reset	0	0	0	0	0	0	0	0
Bit	7	6	5	4	3	2	1	0
	DATA[7:0]							
Access	R	R	R	R	R	R	R	R
Reset	0	0	0	0	0	0	0	1

**Bits 31:0 – DATA[31:0]** Page Buffer Data

## 27.6.11 ECC Error Status

**Name:** ECCERR  
**Offset:** 0x24  
**Reset:** 0x00000000  
**Property:** -

This register tracks errors on the NVM read path.

ECC error tracking is active until an error is detected. It is still active in case of single error but no dual error. In this case only a dual error can override this register status as a dual error is more critical than a single error. Error tracking resumes as soon as this register is read.

Bit	31	30	29	28	27	26	25	24
	TYPEH[1:0]		TYPEL[1:0]					
Access	R	R	R	R				
Reset	0	0	0	0				
Bit	23	22	21	20	19	18	17	16
	ADDR[23:16]							
Access	R	R	R	R	R	R	R	R
Reset	0	0	0	0	0	0	0	0
Bit	15	14	13	12	11	10	9	8
	ADDR[15:8]							
Access	R	R	R	R	R	R	R	R
Reset	0	0	0	0	0	0	0	0
Bit	7	6	5	4	3	2	1	0
	ADDR[7:0]							
Access	R	R	R	R	R	R	R	R
Reset	0	0	0	0	0	0	0	0

### Bits 31:30 – TYPEH[1:0] High Double-Word Error Type

Indicates the type of error detected on the NVM 64-bit most significant read word. It is reset to None when this register is read except if an error occurs in the same cycle.

Value	Name	Description
0x0	NONE	No Error Detected Since Last Read
0x1	SINGLE	At Least One Single Error Detected Since last Read
0x2	DUAL	At Least One Dual Error Detected Since Last Read
0x3	-	Reserved

### Bits 29:28 – TYPEL[1:0] Low Double-Word Error Type

Indicates the type of error detected on the NVM 64-bit less significant read word. It is reset to None when this register is read except if an error occurs in the same cycle.

Value	Name	Description
0x0	NONE	No Error Detected Since Last Read
0x1	SINGLE	At Least One Single Error Detected Since last Read
0x2	DUAL	At Least One Dual Error Detected Since Last Read
0x3	-	Reserved

### Bits 23:0 – ADDR[23:0] Error Address

Indicates the Byte address of the last detected error.

## 27.6.12 Debug Control

**Name:** DBGCTRL  
**Offset:** 0x28  
**Reset:** 0x00  
**Property:** PAC Write-Protection

Bit	7	6	5	4	3	2	1	0
							ECCELOG	ECCDIS
Access							R/W	R/W
Reset							0	0

### Bit 1 – ECCELOG Debugger ECC Error Tracking Mode

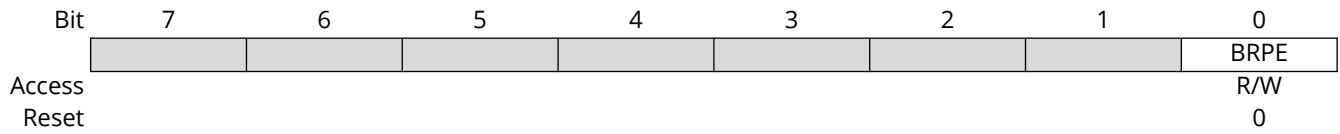
0: ECC errors detected during a read initiated by a debugger are not logged.  
 1: ECC errors detected during a read initiated by a debugger are logged.

### Bit 0 – ECCDIS Debugger ECC Read Disable

Value	Description
0	ECC errors for debugger reads are corrected and logged in INTFLAG
1	ECC errors for debugger reads are not corrected or logged in INTFLAG

### 27.6.13 Boot Control

**Name:** BCTRL  
**Offset:** 0x29  
**Reset:** 0x00  
**Property:** PAC Write-Protection



#### Bit 0 – BRPE Boot Read Protection Enable

Value	Description
0	Boot Read Protection is disabled
1	Boot Read Protection is enabled

## 27.6.14 SmartEEPROM Configuration

**Name:** SEECFG  
**Offset:** 0x2A  
**Reset:** 0x00  
**Property:** PAC Write-Protection

Bit	7	6	5	4	3	2	1	0
Access							APRDIS	WMODE
Reset							R/W 0	R/W 0

**Bit 1 – APRDIS** Automatic Page Reallocation Disable  
 0: enables the Automatic page Reallocation.  
 1: disables the Automatic page Reallocation.

**Bit 0 – WMODE** Write Mode  
 Indicates the type of bufferization used.

Value	Name	Description
0x0	UNBUFFERED	A NVM write command is issued after each write in the pagebuffer
0x1	RESERVED	-

### 27.6.15 SmartEEPROM Status

**Name:** SEESTAT  
**Offset:** 0x2C  
**Reset:** 0x000X0X0X  
**Property:** Read-Only

Bit	31	30	29	28	27	26	25	24
Access								
Reset								
Bit	23	22	21	20	19	18	17	16
Access						R	R	R
Reset						x	x	x
Bit	15	14	13	12	11	10	9	8
Access					R	R	R	R
Reset					x	x	x	x
Bit	7	6	5	4	3	2	1	0
Access				RLOCK	LOCK	BUSY	Reserved	ASEES
Reset				R	R	R	R	R
				0	x	0	0	x

#### Bits 18:16 – PSZ[2:0] SmartEEPROM Page Size

This bit field is automatically loaded from the user page during startup (refer to the Memories chapter).  
 Indicates the page size.

#### Bits 11:8 – SBLK[3:0] Blocks Number In a Sector

This bit field is automatically loaded from the user page during startup (refer to the Memories chapter).  
 Indicates the number of blocks allocated to a SEES.

#### Bit 4 – RLOCK RLOCK

SmartEEPROM Write Access to Register Address Space Is Locked

#### Bit 3 – LOCK SmartEEPROM Section Locked

This bit field is automatically loaded from the user page during startup.  
 Access to the SmartEEPROM data is locked. Writes to AHB2 throws hardfault exceptions.  
 0: SmartEEPROM access is not locked  
 1: SmartEEPROM access is locked

#### Bit 2 – BUSY Busy

0: SmartEEPROM is ready.  
 1: SmartEEPROM is busy processing a read or a write operation.

#### Bit 1 – Reserved

**Bit 0 – ASEES** Active SmartEEPROM Sector

This bit field is automatically loaded during startup from a special fuse in the NVM.

Indicates the active SEES

0: SEES0 is active

1: SEES1 is active



## 28. RAM Error Correction Code (RAMECC)

### 28.1 Overview

For safety applications, the PIC32CX SG41/SG60/SG61 family of devices can embed error correction codes (ECC) to detect and correct single bit errors or to enable dual error detection in SRAM. As discussed in the “Memories” chapter, when the RAMECC is enabled, the top half of SRAM memory will be reserved to store error correction codes and will not be available for the application.

ECC calculation is software selectable through the RAM ECCDIS bit in the NVM User Row. For additional information, refer to [NVM User Row Mapping - Dedicated Entries](#).

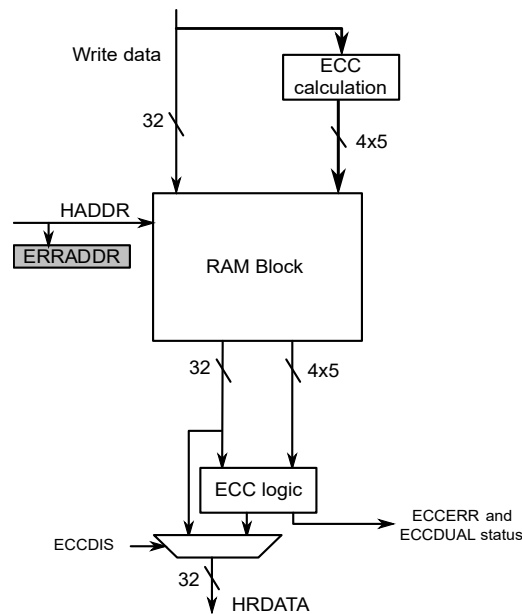
### 28.2 Features

The following are key features of the RAMECC:

- Single bit correction and dual bit detection
- Error Interrupt

### 28.3 Block Diagram

Figure 28-1. RAMECC Block Diagram



### 28.4 Peripheral Dependencies

Peripheral Name	RAMECC – RAM Error Correction Code (ECC)
Base Address	0x4102_0000 (Peripheral Bus B)
NVIC IRQ Index:Source	45 : SINGLEE, DUALE
MCLK APB Clock (1)	CLK_RAMECC_APB, Enabled, APBBMASK.RAMECC
GCLK Peripheral Channel Index:Clock Name	n/a
PAC Peripheral Identifier (PAC.WRCTRL)	48

**Note:**

1. Clock Name, Default State, Mask Field.

### 28.4.1 Power Management

The RAMECC will continue to operate in any sleep mode where the selected source clock is running. The RAMECC's interrupts can be used to wake up the device from sleep modes. Refer to the [Power Manager](#) chapter for details on the different sleep modes.

### 28.4.2 Debug Operation

When the CPU is halted in debug mode the RAMECC will correct and log ECC errors based on the table below.

**Table 28-1.** ECC Debug Operation

DBGCTRL.ECCELOG	DBGCTRL.ECCDIS	Description
0	0	ECC errors from debugger reads are corrected but not logged in INTFLAG.
1	0	ECC errors from debugger reads are corrected and logged in INTFLAG.
X	1	ECC errors from debugger reads are not corrected or logged in INTFLAG.

If the RAMECC is configured in a way that requires it to be periodically serviced by the CPU through interrupts or similar, improper operation or data loss may result during debugging.

### 28.4.3 Register Access Protection

All registers with write-access are optionally write-protected by the [Peripheral Access Controller \(PAC\)](#), except the following registers:

- Interrupt Flag Status and Clear (INTFLAG) register
- Status (STATUS) register.

Write-protection is denoted by the Write-Protected property in the register description.

Write-protection does not apply to accesses through an external debugger. Refer to the [Peripheral Access Controller](#) chapter for details.

## 28.5 Functional Description

### 28.5.1 Principle of Operation

Error Correcting Code (ECC) is implemented to detect and correct errors that may arise in the RAM arrays. The ECC logic is capable of double error detection and single error correction per 8-bit byte.

Upon single bit error detection, the Single Bit Error interrupt flag is raised (INTFLAG.SINGLEEE). If a dual error is detected, the Dual Error interrupt flag (INTFLAG.DUALE) is raised. When the first error is detected, the ERRADDR register is frozen with the failing address and remains frozen until INTFLAG.DUALE and INTFLAG.SINGLEEE are cleared. If a dual bit error occurs while INTFLAG.SINGLEEE is set, the ERRADDR register is updated with the dual bit error information and INTFLAG.DUALE is also set.

The INTFLAG.SINGLEEE and INTFLAG.DUALE bits are both cleared on ERRADDR read.

The [block diagram](#) shows the ECC interface. When ECC is disabled (CTRLA.ECCDIS = 1), the ECC field in RAM is left unchanged on writes. On reads, ECC errors are not corrected or flagged.

### 28.5.2 Interrupts

The RAMECC has the following interrupt sources:

- Dual Bit Error (DUALE): Indicates that a dual bit error has been detected.
- Single Bit Error (SINGLEEE): Indicates that a single bit error has been detected.

Each interrupt source has an interrupt flag associated with it. The interrupt flag in the Interrupt Flag Status and Clear (INTFLAG) register is set when the interrupt condition occurs.

Each interrupt can be individually enabled by writing a '1' to the corresponding bit in the Interrupt Enable Set (INTENSET) register, and disabled by writing a '1' to the corresponding bit in the Interrupt Enable Clear (INTENCLR) register.

An interrupt request is generated when the interrupt flag is set and the corresponding interrupt is enabled. The interrupt request remains active until the ERRADDR register is read, the interrupt is disabled, or the RAMECC is reset.

All interrupt requests from the peripheral are ORed together on system level to generate one combined interrupt request to the [NVIC](#). The user must read the INTFLAG register to determine which interrupt condition is present.

**Note:** Interrupts must be globally enabled for interrupt requests to be generated.

## 28.6 Register Summary

Offset	Name	Bit Pos.	7	6	5	4	3	2	1	0	
0x00	INTENCLR	7:0							DUALE	SINGLEE	
0x01	INTENSET	7:0							DUALE	SINGLEE	
0x02	INTFLAG	7:0							DUALE	SINGLEE	
0x03	STATUS	7:0								ECCDIS	
0x04	ERRADDR	7:0	ERRADDR[7:0]								
		15:8	ERRADDR[15:8]								
		23:16									ERRADDR[16]
		31:24									
0x08 ... 0x0E	Reserved										
0x0F	DBGCTRL	7:0							ECCELOG	ECCDIS	

### 28.6.1 Interrupt Enable Clear

**Name:** INTENCLR  
**Offset:** 0x00  
**Reset:** 0x00  
**Property:** PAC Write-Protection

This register allows the user to disable an interrupt without doing a read-modify-write operation. Changes in this register will also be reflected in the Interrupt Enable Set (INTENSET) register.

Bit	7	6	5	4	3	2	1	0
							DUALE	SINGLEE
Access							R/W	R/W
Reset							0	0

#### Bit 1 – DUALE Dual Bit Error Interrupt Enable Clear

Writing a '0' to this bit has no effect.

Writing a '1' to this bit will clear the Dual Bit Error Interrupt Enable bit, which disables the Dual Bit Error interrupt.

Value	Description
0	The Dual Bit Error interrupt is disabled.
1	The Dual Bit Error interrupt is enabled.

#### Bit 0 – SINGLEE Single Bit Error Interrupt Enable Clear

Writing a '0' to this bit has no effect.

Writing a '1' to this bit will clear the Single Bit Error Interrupt Enable bit, which disables the Single Bit Error interrupt.

Value	Description
0	The Single Bit Error interrupt is disabled.
1	The Single Bit Error interrupt is enabled.

## 28.6.2 Interrupt Enable Set

**Name:** INTENSET  
**Offset:** 0x01  
**Reset:** 0x00  
**Property:** Write-Protected

This register allows the user to enable an interrupt without doing a read-modify-write operation. Changes in this register will also be reflected in the Interrupt Enable Clear (INTENCLR) register.

Bit	7	6	5	4	3	2	1	0
							DUALE	SINGLEE
Access							R/W	R/W
Reset							0	0

### Bit 1 – DUALE Dual Bit Error Interrupt Enable Set

Writing a '0' to this bit has no effect.

Writing a '1' to this bit will set the Dual Bit Error Interrupt Enable bit, which enables the Dual Bit Error interrupt.

Value	Description
0	The Dual Bit Error interrupt is disabled.
1	The Dual Bit Error interrupt is enabled.

### Bit 0 – SINGLEE Single Bit Error Interrupt Enable Set

Writing a '0' to this bit has no effect.

Writing a '1' to this bit will clear the Single Bit Error Interrupt Enable bit, which disables the Single Bit Error interrupt.

Value	Description
0	The Single Bit Error interrupt is disabled.
1	The Single Bit Error interrupt is enabled.

### 28.6.3 Interrupt Flag Status and Clear

**Name:** INTFLAG  
**Offset:** 0x02  
**Reset:** 0x00

Bit	7	6	5	4	3	2	1	0
							DUALE	SINGLEE
Access							R/W	R/W
Reset							0	0

#### Bit 1 – DUALE Dual Bit ECC Error Interrupt

This flag is set on the occurrence of a dual bit ECC error.

Writing a '0' to this bit has no effect.

Reading the ECCADDR register will clear the Dual Bit Error interrupt flag.

Value	Description
0	No dual bit errors have been received since the last clear.
1	At least one dual bit error has occurred since the last clear.

#### Bit 0 – SINGLEE Single Bit ECC Error Interrupt

This flag is set on the occurrence of a single bit ECC error.

Writing a '0' to this bit has no effect.

Reading the ECCADDR register will clear the Single Bit Error interrupt flag.

Value	Description
0	No errors have been received since the last clear.
1	At least one single bit error has occurred since the last clear.

## 28.6.4 Status

**Name:** STATUS  
**Offset:** 0x03  
**Reset:** 0x00  
**Property:** Read Only

Bit	7	6	5	4	3	2	1	0
								ECCDIS
Access								R
Reset								0

### Bit 0 – ECCDIS ECC Disable

This bit is fuse updated at startup. When enabled, the calculated ECC is written to RAM along with data. ECC correction and detection is enabled for reads.

Value	Description
0	ECC detection and correction is enabled.
1	ECC detection and correction is disabled.



### 28.6.5 Error Address

**Name:** ERRADDR  
**Offset:** 0x04  
**Reset:** 0x00000000  
**Property:** R

Bit	31	30	29	28	27	26	25	24
Access								
Reset								
Bit	23	22	21	20	19	18	17	16
Access								ERRADDR[16]
Reset								R
Reset								0
Bit	15	14	13	12	11	10	9	8
Access	ERRADDR[15:8]							
Reset	R	R	R	R	R	R	R	R
Reset	0	0	0	0	0	0	0	0
Bit	7	6	5	4	3	2	1	0
Access	ERRADDR[7:0]							
Reset	R	R	R	R	R	R	R	R
Reset	0	0	0	0	0	0	0	0

#### Bits 16:0 – ERRADDR[16:0] ECC Error Address

The RAM address offset from RAM start that caused an ECC error. If a single bit error is followed by a dual bit error, this register will be updated with the address of the dual bit error, otherwise it stalls on the first error occurrence. This register will read as zero unless INTFLAG.SINGLEEE and/or INTFLAG.DUALE are 1.

## 28.6.6 Debug Control

**Name:** DBGCTRL  
**Offset:** 0x0F  
**Reset:** 0x00  
**Property:** PAC Write-Protection

Bit	7	6	5	4	3	2	1	0
							ECCELOG	ECCDIS
Access							R/W	R/W
Reset							0	0

### Bit 1 - ECCELOG ECC Error Log

When DBGCTRL.ECCDIS=0, This bit controls whether ECC errors are logged in the INTFLAG register. When DBGCTRL.ECCDIS=1, this bit has no meaning.

Value	Description
0	ECC errors for debugger reads are not logged.
1	ECC errors for debugger reads are logged if DBGCTRL.ECCDIS=0.

### Bit 0 - ECCDIS ECC Disable

By default, ECC errors during debugger reads are corrected and logged based on DBGCTRL.ECCELOG. Setting this bit will disable ECC correction and logging.

Value	Description
0	ECC errors are corrected for debugger reads and logged based on DBGCTRL.ECCELOG.
1	ECC errors are masked for debugger reads.

## 29. I/O Pin Controller (PORT)

### 29.1 Overview

The I/O Pin Controller (PORT) controls the I/O pins of the device. The I/O pins are organized in a series of groups, collectively referred to as a PORT group. Each PORT group can have up to 32 pins that can be configured and controlled individually or as a group. The number of PORT groups on a device may depend on the package or number of pins. Each pin may either be used for general purpose I/O under direct application control or be assigned to an embedded device peripheral. When used for general purpose I/O, each pin can be configured as input or output, with a highly configurable driver and pull settings.

All I/O pins have true read-modify-write functionality when used for general purpose I/O. The direction or the output value of one or more pins may be changed (set, Reset or toggled) explicitly without unintentionally changing the state of any other pins in the same port group by a single, atomic 8-bit, 16-bit, or 32-bit write.

The PORT is connected to the high-speed bus matrix through an AHB/APB bridge.

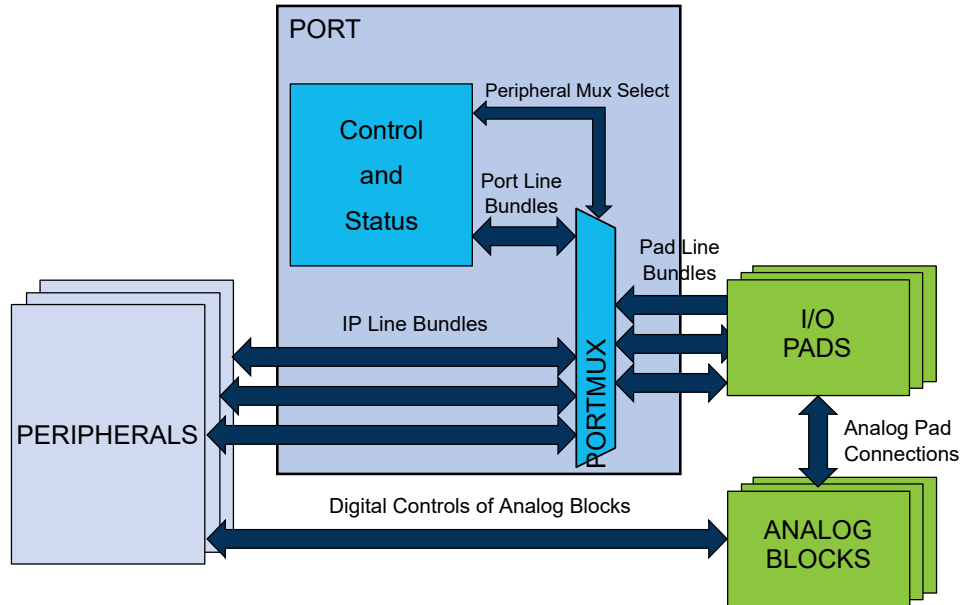
### 29.2 Features

The following are key features of the PORT:

- Selectable Input and Output Configuration for Each Individual Pin
- Software-controlled Multiplexing of Peripheral Functions on I/O Pins
- Flexible Pin Configuration Through a Dedicated Pin Configuration Register
- Configurable Output Driver and Pull Settings:
  - Totem-pole (push-pull)
  - Pull configuration
  - Driver strength
- Configurable Input Buffer and Pull Settings:
  - Internal pull up or pull down
  - Input sampling criteria
  - Input buffer can be disabled if not needed for low-power consumption
  - Read-Modify-Write support for output value (OUTCLR/OUTSET/OUTTGL) and pin direction (DIRCLR/DIRSET/DIRTGL)
- Input Event:
  - Up to four input event pins for each PORT group
  - SET/CLEAR/TOGGLE event actions for each event input on output value of a pin
  - Can be output to pin

## 29.3 Block Diagram

Figure 29-1. PORT Block Diagram



## 29.4 Signal Description

Table 29-1. Signal Description for PORT

Signal name	Type	Description
Pxy	Digital I/O	General purpose I/O pin y in group x

Refer to the [Pinout](#) for details on the pin mapping for this peripheral. One signal can be mapped on several pins.

## 29.5 Peripheral Dependencies

<b>Peripheral Name</b>	PORT - I/O Pin Controller
<b>Base Address</b>	0x4100_8000 (Peripheral Bus B)
<b>MCLK APB Clock (1)</b>	CLK_PORT_APB, Enabled, APBBMASK.PORT
<b>GCLK Peripheral Channel Index:Clock Name</b>	n/a
<b>PAC Peripheral Identifier (PAC.WRCTRL)</b>	36
<b>DMA Trigger Index:Source (DMAC.CHCTRLk,k=0,1,...31)</b>	n/a
<b>EVSYS Users (EVSYS.USERm) (2)</b>	1-4 : Port Event x, x=0..3 (PORT EVx) (A)
<b>EVSYS Generators (EVSYS.CHANNELn)</b>	n/a
<b>Notes:</b>	
1.	Clock Name, Default State, Mask Field.
2.	(A,S,R): A = Asynchronous path, S = Synchronous path, R = Resynchronized path.

### 29.5.1 I/O Lines

The I/O lines of the PORT are mapped to pins of the physical device. The following naming scheme is used:

Each line bundle with up to 32 lines is assigned an identifier 'xy', with letter x = A, B, C... and two-digit number y = 00, 01, ...31. Examples: A24, C03.

PORT pins are labeled 'Pxy' accordingly, for example PA24, PC03. This identifies each pin in the device uniquely.

Each pin may be controlled by one or more peripheral multiplexer settings, which allows the pad to be routed internally to a dedicated peripheral function. When the setting is enabled, the selected peripheral has control over the Output state of the pad, as well as the ability to read the current Physical Pad state. Refer to the [Pinout](#) for additional information.

Device-specific configurations may cause some lines (and the corresponding Pxy pin) not to be implemented.

### 29.5.2 Power Management

During Reset, all PORT lines are configured as inputs with input buffers, output buffers and pull disabled.

When the device is set to the BACKUP sleep mode, even if the PORT configuration registers and input synchronizers will lose their contents (these will not be restored when PORT is powered up again), the latches in the pads will keep their current configuration, such as the output value and pull settings. Refer to the [Power Manager](#) for more features related to the I/O lines configuration in and out of BACKUP mode.

The PORT peripheral will continue operating in any Sleep mode where its source clock is running.

### 29.5.3 Clocks

The PORT bus clock (CLK\_PORT\_APB) can be enabled and disabled in the Main Clock module, and the default state of CLK\_PORT\_APB can be found in the [Peripheral Clock Masking](#) section in MCLK – Main Clock.

The PORT requires an APB clock, which may be divided from the CPU main clock and allows the CPU to access the registers of PORT through the high-speed matrix and the AHB/APB bridge.

One clock cycle latency can be observed on the APB access in case of concurrent PORT accesses.

### 29.5.4 Events

The output of an event to a pin through PORT is always asynchronous. This must be configured in the Event System by writing ASYNCHRONOUS to the Path Selection bits in the respective Channel n Control register of the Event System (EVSYS.CHANNELn.PATH).

### 29.5.5 Debug Operation

When the CPU is halted in Debug mode, this peripheral will continue normal operation.

### 29.5.6 Register Access Protection

All registers with write-access are optionally write-protected by the [Peripheral Access Controller \(PAC\)](#), except for the following registers:

- Interrupt Flag (INTFLAG) register

**Note:** Optional write protection is indicated by the "PAC Write Protection" property in the register description.

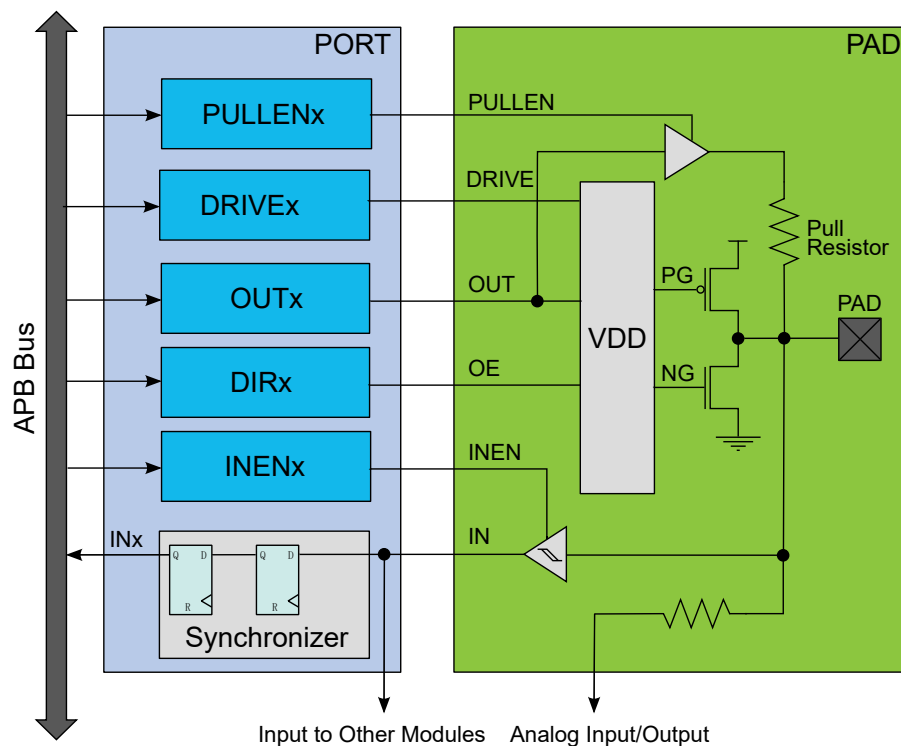
Write protection does not apply for accesses through an external debugger.

### 29.5.7 Analog Connections

Analog functions are connected directly between the analog blocks and the I/O pads using analog buses. Selecting an analog peripheral function for a given pin will disable the corresponding digital features of the pad.

## 29.6 Functional Description

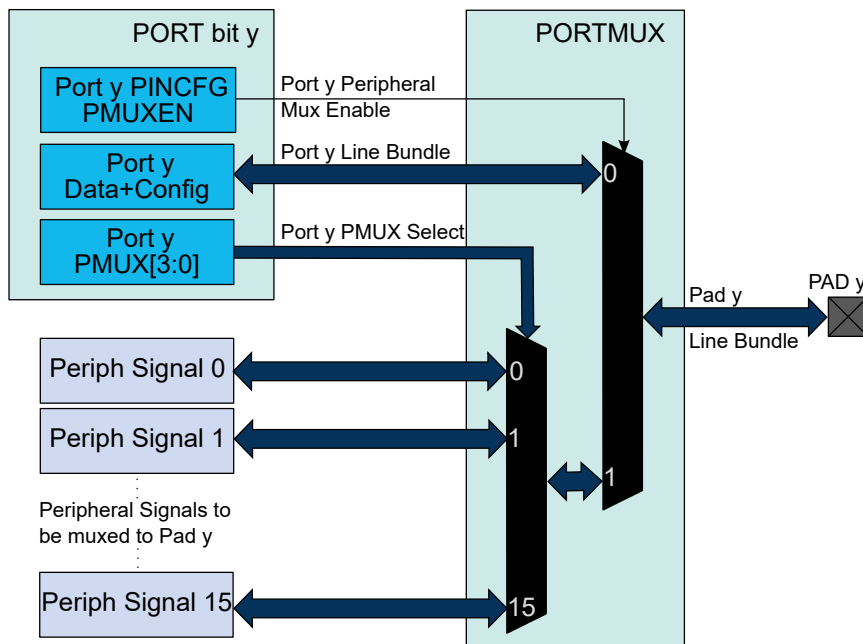
Figure 29-2. Overview of the PORT



### 29.6.1 Principle of Operation

Each PORT group of up to 32 pins is controlled by the registers in PORT, as described in the figure. These registers in PORT are duplicated for each PORT group, with increasing base addresses using an offset of 0x80 between groups. The number of PORT groups may depend on the package/number of pins.

**Figure 29-3.** Overview of the Peripheral Functions Multiplexing



The I/O pins of the device are controlled by PORT peripheral registers. Each port pin has a corresponding bit in the Data Direction (DIR) and Data Output Value (OUT) registers to enable that pin as an output and to define the Output state.

The direction of each pin in a PORT group is configured by the DIR register. If a bit in DIR is set to '1', the corresponding pin is configured as an output pin. If a bit in DIR is set to '0', the corresponding pin is configured as an input pin.

When the direction is set as output, the corresponding bit in the OUT register will set the level of the pin. If bit y in OUT is written to '1', pin y is driven HIGH. If bit y in OUT is written to '0', pin y is driven LOW. Pin configuration can be set by Pin Configuration (PINCFGy) registers, with y = 00, 01, ..31 representing the pin number within the group.

The Data Input Value (IN) is set as the input value of a port pin with resynchronization to the PORT clock. To reduce power consumption, these input synchronizers can be clocked only when system requires reading the input value, as specified in the SAMPLING field of the Control register (CTRL). The value of the pin can always be read, whether the pin is configured as input or output. If the Input Enable bit in the Pin Configuration registers (PINCFGy.INEN) is '0', the input value will not be sampled.

In PORT, the Peripheral Multiplexer Enable bit in the PINCFGy register (PINCFGy.PMUXEN) can be written to '1' to enable the connection between peripheral functions and individual I/O pins. The Peripheral Multiplexing n (PMUXn) registers select the peripheral function for the corresponding pin. This will override the connection between the PORT and that I/O pin, and connect the selected peripheral signal to the particular I/O pin instead of the PORT line bundle.

## 29.6.2 Basic Operation

### 29.6.2.1 Initialization

After reset, all standard function device I/O pads are connected to the PORT with outputs tri-stated and input buffers disabled, even if there is no clock running.

However, specific pins, such as those used for connection to a debugger, may be configured differently, as required by their special function.

## 29.6.2.2 Operation

Each I/O pin Pxy can be controlled by the registers in PORT. Each PORT group x has its own set of PORT registers, with a base address at byte address (PORT + 0x80 \* group index) (A corresponds to group index 0, B to 1, etc...). Within that set of registers, the pin index is y, from 0 to 31.

Refer to the [Pinout](#) for details on available pin configuration and PORT groups.

### Configuring Pins as Output

To use pin Pxy as an *output*, write bit y of the DIR register to '1'. This can also be done by writing bit y in the DIRSET register to '1' - this will avoid disturbing the configuration of other pins in that group. The y bit in the OUT register must be written to the desired output value.

Similarly, writing an OUTSET bit to '1' will set the corresponding bit in the OUT register to '1'. Writing a bit in OUTCLR to '1' will set that bit in OUT to zero. Writing a bit in OUTTGL to '1' will toggle that bit in OUT.

### Configuring Pins as Input

To use pin Pxy as an *input*, bit y in the DIR register must be written to '0'. This can also be done by writing bit y in the DIRCLR register to '1' - this will avoid disturbing the configuration of other pins in that group. The input value can be read from bit y in register IN as soon as the INEN bit in the Pin Configuration register (PINCFGy.INEN) is written to '1' to enable the pin's input buffer.

By default, the input synchronizer is clocked only when an input read is requested. This will delay the read operation by two cycles of the PORT clock. To remove the delay, the input synchronizers for each PORT group of eight pins can be configured to be always active, but this will increase power consumption. This is enabled by writing '1' to the corresponding SAMPLINGn bit field of the CTRL register, see CTRL.SAMPLING for details.

### Using Alternative Peripheral Functions

To use pin Pxy as one of the available peripheral functions, the corresponding PMUXEN bit of the PINCFGy register must be '1'. The PINCFGy register for pin Pxy is at byte offset (PINCFG0 + y).

The peripheral function can be selected by setting the PMUXO or PMUXE in the PMUXn register. The PMUXO/PMUXE is at byte offset PMUX0 + (y/2). The chosen peripheral must also be configured and enabled.

## 29.6.3 I/O Pin Configuration

The Pin Configuration register (PINCFGy) is used for additional I/O pin configuration. A pin can be set in a totem-pole or pull configuration.

As pull configuration is done through the Pin Configuration register, all intermediate PORT states during switching of pin direction and pin values are avoided.

The I/O pin configurations are described further in this chapter, and summarized in [Table 29-2](#).

### 29.6.3.1 Pin Configurations Summary

**Table 29-2.** Pin Configurations Summary

DIR	INEN	PULLEN	OUT	Configuration
0	0	0	X	Reset or analog I/O: all digital disabled
0	0	1	0	Pull-down; input buffer disabled
0	0	1	1	Pull-up; input buffer disabled
0	1	0	X	Input
0	1	1	0	Input with pull-down
0	1	1	1	Input with pull-up
1	0	X	X	Output; input buffer disabled
1	1	X	X	Output; input buffer enabled



### 29.6.3.2 Input Configuration

Figure 29-4. I/O configuration - Standard Input

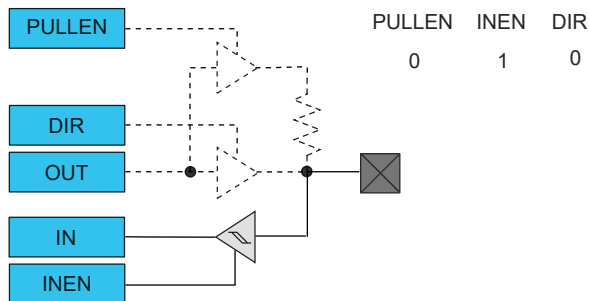
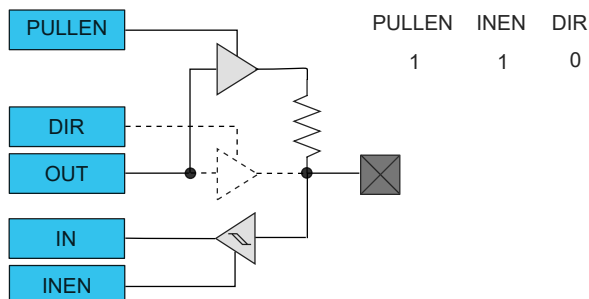


Figure 29-5. I/O Configuration - Input with Pull



**Note:** When pull is enabled, the pull value is defined by the OUT value.

### 29.6.3.3 Totem-Pole Output

When configured for totem-pole (push-pull) output, the pin is driven low or high according to the corresponding bit setting in the OUT register. In this configuration there is no current limitation for sink or source other than what the pin is capable of. If the pin is configured for input, the pin will float if no external pull is connected.

**Note:** Enabling the output driver will automatically disable pull.

Figure 29-6. I/O Configuration - Totem-Pole Output with Disabled Input

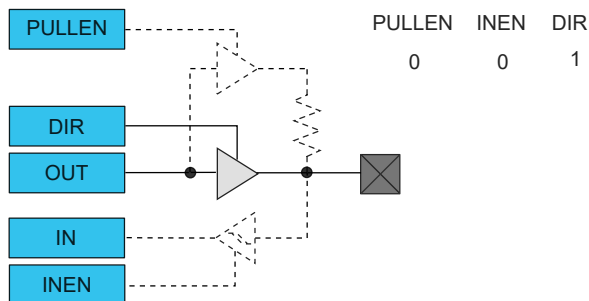


Figure 29-7. I/O Configuration - Totem-Pole Output with Enabled Input

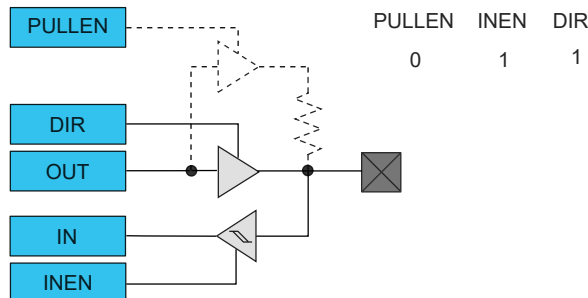
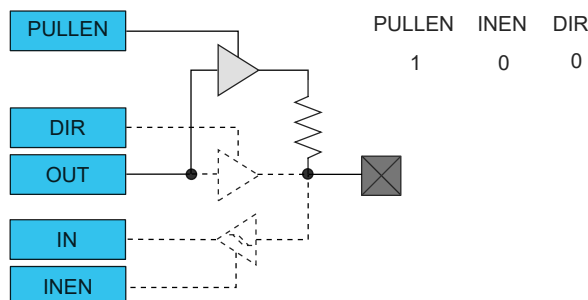


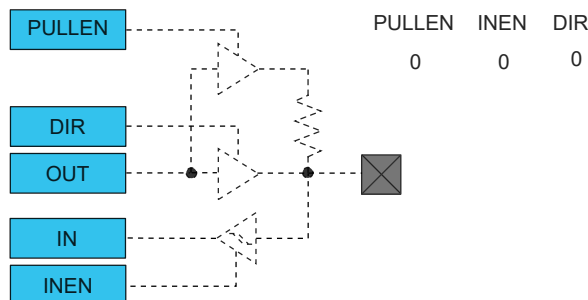
Figure 29-8. I/O Configuration - Output with Pull



### 29.6.3.4 Digital Functionality Disabled

Neither Input nor Output functionality are enabled.

Figure 29-9. I/O Configuration - Reset or Analog I/O: Digital Output, Input and Pull Disabled



### 29.6.4 Events

The PORT allows input events to control individual I/O pins. These input events (EVU0-3) are generated by the EVSYS module and can originate from a different clock domain than the PORT module's clock domain.

The PORT can perform the following actions:

- **Output (OUT):** I/O pin will be set when the incoming event has a high level ('1'), and cleared when the incoming event has a low-level ('0')
- **Set (SET):** I/O pin will be set when an incoming event is detected
- **Clear (CLR):** I/O pin will be cleared when an incoming event is detected
- **Toggle (TGL):** I/O pin will toggle when an incoming event is detected

The Output event is sent to the pin without any internal latency. For SET, CLEAR and TOGGLE event actions, the action will be executed up to three clock cycles after a rising edge.

**Note:** In Standby mode, only the Output action is possible. The Set, Clear, and Toggle actions are not available.

The event actions can be configured with the Event Action m bit group in the Event Input Control register( EVCTRL.EVACTn). Writing a '1' to a PORT Event Enable Input m of the Event Control register (EVCTRL.PORTEIn) enables the corresponding action on input event. Writing '0' to this bit disables the corresponding action on input event. Note that several actions can be enabled for incoming events. If several events are connected to the peripheral, any enabled action will be taken for any of the incoming events. Refer to the [EVSYS – Event System](#) section for details on configuring the Event System.

Each event input can address one and only one I/O pin at a time. The selection of the pin is indicated by the PORT Event Pin Identifier of the Event Input Control register (EVCTR.PIDn). On the other hand, one I/O pin can be addressed by up to four different input events. To avoid action conflict on the output value of the register (OUT) of this particular I/O pin, only one action is performed according to the table below.

Note that this truth table can be applied to any SET/CLR/TGL configuration from two to four active input events.

**Table 29-3.** Priority on Simultaneous SET/CLR/TGL Event Actions

EVACT0	EVACT1	EVACT2	EVACT3	Executed Event Action
SET	SET	SET	SET	SET
CLR	CLR	CLR	CLR	CLR
All Other Combinations				TGL

Be careful when the event is Output (OUT) to pin. Due to the fact the events are received asynchronously, the I/O pin may have unpredictable levels, depending on the timing of when the events are received. When several events are output to the same pin, the lowest event line will get the access. All other events will be ignored.

### 29.6.5 PORT Access Priority

The PORT is accessed by different systems:

- The Arm CPU through the high-speed matrix and the AHB/APB bridge (APB)
- EVSYS through four asynchronous input events

The following priority is adopted:

1. APB.
2. EVSYS input events, except for events with EVCTRL.EVACTn = OUT, where the output pin follows the event input signal, independently of the OUT register value.

**Note:** One clock cycle latency can be observed on the APB access in case of concurrent PORT accesses.

For input events that require different actions on the same I/O pin, refer to [29.6.4. Events](#).

## 29.7 Register Summary

The I/O pins are assembled in pin groups with up to 32 pins. Group 0 consists of the PA pins, and group 1 is for the PB pins, etc. Each pin group has its own PORT registers, with a 0x80 address spacing between groups. For example, the register address offset for the Data Direction (DIR) register for group 0 (PA00 to PA31) is 0x00, and the register address offset for the DIR register for group 1 (PB00 to PB31) is 0x80.

Offset	Name	Bit Pos.	7	6	5	4	3	2	1	0	
0x00	DIR	7:0	DIR[7:0]								
		15:8	DIR[15:8]								
		23:16	DIR[23:16]								
		31:24	DIR[31:24]								
0x04	DIRCLR	7:0	DIRCLR[7:0]								
		15:8	DIRCLR[15:8]								
		23:16	DIRCLR[23:16]								
		31:24	DIRCLR[31:24]								
0x08	DIRSET	7:0	DIRSET[7:0]								
		15:8	DIRSET[15:8]								
		23:16	DIRSET[23:16]								
		31:24	DIRSET[31:24]								
0x0C	DIRTGL	7:0	DIRTGL[7:0]								
		15:8	DIRTGL[15:8]								
		23:16	DIRTGL[23:16]								
		31:24	DIRTGL[31:24]								
0x10	OUT	7:0	OUT[7:0]								
		15:8	OUT[15:8]								
		23:16	OUT[23:16]								
		31:24	OUT[31:24]								
0x14	OUTCLR	7:0	OUTCLR[7:0]								
		15:8	OUTCLR[15:8]								
		23:16	OUTCLR[23:16]								
		31:24	OUTCLR[31:24]								
0x18	OUTSET	7:0	OUTSET[7:0]								
		15:8	OUTSET[15:8]								
		23:16	OUTSET[23:16]								
		31:24	OUTSET[31:24]								
0x1C	OUTTGL	7:0	OUTTGL[7:0]								
		15:8	OUTTGL[15:8]								
		23:16	OUTTGL[23:16]								
		31:24	OUTTGL[31:24]								
0x20	IN	7:0	IN[7:0]								
		15:8	IN[15:8]								
		23:16	IN[23:16]								
		31:24	IN[31:24]								
0x24	CTRL	7:0	SAMPLING[7:0]								
		15:8	SAMPLING[15:8]								
		23:16	SAMPLING[23:16]								
		31:24	SAMPLING[31:24]								
0x28	WRCONFIG	7:0	PINMASK[7:0]								
		15:8	PINMASK[15:8]								
		23:16		DRVSTR					PULLEN	INEN	PMUXEN
		31:24	HWSEL	WRPINCFCG		WRPMUX			PMUXE[3:0]		
0x2C	EVCTRL	7:0	PORTEI0	EVACT0[1:0]			PID0[4:0]				
		15:8	PORTEI1	EVACT1[1:0]			PID1[4:0]				
		23:16	PORTEI2	EVACT2[1:0]			PID2[4:0]				
		31:24	PORTEI3	EVACT3[1:0]			PID3[4:0]				
0x30	PMUX0	7:0	PMUXO[3:0]				PMUXE[3:0]				
...											
0x3F	PMUX15	7:0	PMUXO[3:0]				PMUXE[3:0]				
0x40	PINCFG0	7:0		DRVSTR				PULLEN	INEN	PMUXEN	
...											

.....continued

Offset	Name	Bit Pos.	7	6	5	4	3	2	1	0
0x5F	<a href="#">PINCFG31</a>	7:0		DRVSTR				PULLEN	INEN	PMUXEN

## 29.7.1 Data Direction

**Name:** DIR  
**Offset:** 0x00  
**Reset:** 0x00000000  
**Property:** PAC Write-Protection

This register allows the user to configure one or more I/O pins as an input or output. This register can be manipulated without doing a read-modify-write operation by using the Data Direction Toggle (DIRTGL), Data Direction Clear (DIRCLR) and Data Direction Set (DIRSET) registers.



**Tip:** The I/O pins are assembled in pin groups (“PORT groups”) with up to 32 pins. Group 0 consists of the PA pins, group 1 is for the PB pins, etc. Each pin group has its own PORT registers, with a 0x80 address spacing. For example, the register address offset for the Data Direction (DIR) register for group 0 (PA00 to PA31) is 0x00, and the register address offset for the DIR register for group 1 (PB00 to PB31) is 0x80.

Bit	31	30	29	28	27	26	25	24
	DIR[31:24]							
Access	RW	RW	RW	RW	RW	RW	RW	RW
Reset	0	0	0	0	0	0	0	0
Bit	23	22	21	20	19	18	17	16
	DIR[23:16]							
Access	RW	RW	RW	RW	RW	RW	RW	RW
Reset	0	0	0	0	0	0	0	0
Bit	15	14	13	12	11	10	9	8
	DIR[15:8]							
Access	RW	RW	RW	RW	RW	RW	RW	RW
Reset	0	0	0	0	0	0	0	0
Bit	7	6	5	4	3	2	1	0
	DIR[7:0]							
Access	RW	RW	RW	RW	RW	RW	RW	RW
Reset	0	0	0	0	0	0	0	0

### Bits 31:0 – DIR[31:0] Port Data Direction

These bits set the data direction for the individual I/O pins in the PORT group.

Value	Description
0	The corresponding I/O pin in the PORT group is configured as an input.
1	The corresponding I/O pin in the PORT group is configured as an output.

## 29.7.2 Data Direction Clear

**Name:** DIRCLR  
**Offset:** 0x04  
**Reset:** 0x00000000  
**Property:** PAC Write-Protection

This register allows the user to set one or more I/O pins as an input, without doing a read-modify-write operation. Changes in this register will also be reflected in the Data Direction (DIR), Data Direction Toggle (DIRTGL) and Data Direction Set (DIRSET) registers.



**Tip:** The I/O pins are assembled in pin groups (“PORT groups”) with up to 32 pins. Group 0 consists of the PA pins, group 1 is for the PB pins, etc. Each pin group has its own PORT registers, with a 0x80 address spacing. For example, the register address offset for the Data Direction (DIR) register for group 0 (PA00 to PA31) is 0x00, and the register address offset for the DIR register for group 1 (PB00 to PB31) is 0x80.

Bit	31	30	29	28	27	26	25	24
	DIRCLR[31:24]							
Access	RW	RW	RW	RW	RW	RW	RW	RW
Reset	0	0	0	0	0	0	0	0
Bit	23	22	21	20	19	18	17	16
	DIRCLR[23:16]							
Access	RW	RW	RW	RW	RW	RW	RW	RW
Reset	0	0	0	0	0	0	0	0
Bit	15	14	13	12	11	10	9	8
	DIRCLR[15:8]							
Access	RW	RW	RW	RW	RW	RW	RW	RW
Reset	0	0	0	0	0	0	0	0
Bit	7	6	5	4	3	2	1	0
	DIRCLR[7:0]							
Access	RW	RW	RW	RW	RW	RW	RW	RW
Reset	0	0	0	0	0	0	0	0

### Bits 31:0 – DIRCLR[31:0] Port Data Direction Clear

Writing a '0' to a bit has no effect.

Writing a '1' to a bit will clear the corresponding bit in the DIR register, which configures the I/O pin as an input.

Value	Description
0	The corresponding I/O pin in the PORT group will keep its configuration.
1	The corresponding I/O pin in the PORT group is configured as input.

### 29.7.3 Data Direction Set

**Name:** DIRSET  
**Offset:** 0x08  
**Reset:** 0x00000000  
**Property:** PAC Write-Protection

This register allows the user to set one or more I/O pins as an output, without doing a read-modify-write operation. Changes in this register will also be reflected in the Data Direction (DIR), Data Direction Toggle (DIRTGL) and Data Direction Clear (DIRCLR) registers.



**Tip:** The I/O pins are assembled in pin groups (“PORT groups”) with up to 32 pins. Group 0 consists of the PA pins, group 1 is for the PB pins, etc. Each pin group has its own PORT registers, with a 0x80 address spacing. For example, the register address offset for the Data Direction (DIR) register for group 0 (PA00 to PA31) is 0x00, and the register address offset for the DIR register for group 1 (PB00 to PB31) is 0x80.

Bit	31	30	29	28	27	26	25	24
	DIRSET[31:24]							
Access	RW	RW	RW	RW	RW	RW	RW	RW
Reset	0	0	0	0	0	0	0	0
Bit	23	22	21	20	19	18	17	16
	DIRSET[23:16]							
Access	RW	RW	RW	RW	RW	RW	RW	RW
Reset	0	0	0	0	0	0	0	0
Bit	15	14	13	12	11	10	9	8
	DIRSET[15:8]							
Access	RW	RW	RW	RW	RW	RW	RW	RW
Reset	0	0	0	0	0	0	0	0
Bit	7	6	5	4	3	2	1	0
	DIRSET[7:0]							
Access	RW	RW	RW	RW	RW	RW	RW	RW
Reset	0	0	0	0	0	0	0	0

#### Bits 31:0 – DIRSET[31:0] Port Data Direction Set

Writing '0' to a bit has no effect.

Writing '1' to a bit will set the corresponding bit in the DIR register, which configures the I/O pin as an output.

Value	Description
0	The corresponding I/O pin in the PORT group will keep its configuration.
1	The corresponding I/O pin in the PORT group is configured as an output.



## 29.7.4 Data Direction Toggle

**Name:** DIRTGL  
**Offset:** 0x0C  
**Reset:** 0x00000000  
**Property:** PAC Write-Protection

This register allows the user to toggle the direction of one or more I/O pins, without doing a read-modify-write operation. Changes in this register will also be reflected in the Data Direction (DIR), Data Direction Set (DIRSET) and Data Direction Clear (DIRCLR) registers.



**Tip:** The I/O pins are assembled in pin groups (“PORT groups”) with up to 32 pins. Group 0 consists of the PA pins, group 1 is for the PB pins, etc. Each pin group has its own PORT registers, with a 0x80 address spacing. For example, the register address offset for the Data Direction (DIR) register for group 0 (PA00 to PA31) is 0x00, and the register address offset for the DIR register for group 1 (PB00 to PB31) is 0x80.

Bit	31	30	29	28	27	26	25	24
	DIRTGL[31:24]							
Access	RW	RW	RW	RW	RW	RW	RW	RW
Reset	0	0	0	0	0	0	0	0
Bit	23	22	21	20	19	18	17	16
	DIRTGL[23:16]							
Access	RW	RW	RW	RW	RW	RW	RW	RW
Reset	0	0	0	0	0	0	0	0
Bit	15	14	13	12	11	10	9	8
	DIRTGL[15:8]							
Access	RW	RW	RW	RW	RW	RW	RW	RW
Reset	0	0	0	0	0	0	0	0
Bit	7	6	5	4	3	2	1	0
	DIRTGL[7:0]							
Access	RW	RW	RW	RW	RW	RW	RW	RW
Reset	0	0	0	0	0	0	0	0

### Bits 31:0 – DIRTGL[31:0] Port Data Direction Toggle

Writing '0' to a bit has no effect.

Writing '1' to a bit will toggle the corresponding bit in the DIR register, which reverses the direction of the I/O pin.

Value	Description
0	The corresponding I/O pin in the PORT group will keep its configuration.
1	The direction of the corresponding I/O pin is toggled.

## 29.7.5 Data Output Value

**Name:** OUT  
**Offset:** 0x10  
**Reset:** 0x00000000  
**Property:** PAC Write-Protection

This register sets the data output drive value for the individual I/O pins in the PORT.

This register can be manipulated without doing a read-modify-write operation by using the Data Output Value Clear (OUTCLR), Data Output Value Set (OUTSET), and Data Output Value Toggle (OUTTGL) registers.



**Tip:** The I/O pins are assembled in pin groups (“PORT groups”) with up to 32 pins. Group 0 consists of the PA pins, group 1 is for the PB pins, etc. Each pin group has its own PORT registers, with a 0x80 address spacing. For example, the register address offset for the Data Direction (DIR) register for group 0 (PA00 to PA31) is 0x00, and the register address offset for the DIR register for group 1 (PB00 to PB31) is 0x80.

Bit	31	30	29	28	27	26	25	24
	OUT[31:24]							
Access	RW	RW	RW	RW	RW	RW	RW	RW
Reset	0	0	0	0	0	0	0	0
Bit	23	22	21	20	19	18	17	16
	OUT[23:16]							
Access	RW	RW	RW	RW	RW	RW	RW	RW
Reset	0	0	0	0	0	0	0	0
Bit	15	14	13	12	11	10	9	8
	OUT[15:8]							
Access	RW	RW	RW	RW	RW	RW	RW	RW
Reset	0	0	0	0	0	0	0	0
Bit	7	6	5	4	3	2	1	0
	OUT[7:0]							
Access	RW	RW	RW	RW	RW	RW	RW	RW
Reset	0	0	0	0	0	0	0	0

### Bits 31:0 – OUT[31:0] PORT Data Output Value

For pins configured as outputs via the Data Direction register (DIR), these bits set the logical output drive level.

For pins configured as inputs via the Data Direction register (DIR) and with pull enabled via the Pull Enable bit in the Pin Configuration register (PINCFG.PULLEN), these bits will set the input pull direction.

Value	Description
0	The I/O pin output is driven low, or the input is connected to an internal pull-down.
1	The I/O pin output is driven high, or the input is connected to an internal pull-up.

## 29.7.6 Data Output Value Clear

**Name:** OUTCLR  
**Offset:** 0x14  
**Reset:** 0x00000000  
**Property:** PAC Write-Protection

This register allows the user to set one or more output I/O pin drive levels low, without doing a read-modify-write operation. Changes in this register will also be reflected in the Data Output Value (OUT), Data Output Value Toggle (OUTTGL) and Data Output Value Set (OUTSET) registers.



**Tip:** The I/O pins are assembled in pin groups (“PORT groups”) with up to 32 pins. Group 0 consists of the PA pins, group 1 is for the PB pins, etc. Each pin group has its own PORT registers, with a 0x80 address spacing. For example, the register address offset for the Data Direction (DIR) register for group 0 (PA00 to PA31) is 0x00, and the register address offset for the DIR register for group 1 (PB00 to PB31) is 0x80.

Bit	31	30	29	28	27	26	25	24
	OUTCLR[31:24]							
Access	RW	RW	RW	RW	RW	RW	RW	RW
Reset	0	0	0	0	0	0	0	0
Bit	23	22	21	20	19	18	17	16
	OUTCLR[23:16]							
Access	RW	RW	RW	RW	RW	RW	RW	RW
Reset	0	0	0	0	0	0	0	0
Bit	15	14	13	12	11	10	9	8
	OUTCLR[15:8]							
Access	RW	RW	RW	RW	RW	RW	RW	RW
Reset	0	0	0	0	0	0	0	0
Bit	7	6	5	4	3	2	1	0
	OUTCLR[7:0]							
Access	RW	RW	RW	RW	RW	RW	RW	RW
Reset	0	0	0	0	0	0	0	0

### Bits 31:0 – OUTCLR[31:0] PORT Data Output Value Clear

Writing '0' to a bit has no effect.

Writing '1' to a bit will clear the corresponding bit in the OUT register. Pins configured as outputs via the Data Direction register (DIR) will be set to low output drive level. Pins configured as inputs via DIR and with pull enabled via the Pull Enable bit in the Pin Configuration register (PINCFG.PULLEN) will set the input pull direction to an internal pull-down.

Value	Description
0	The corresponding I/O pin in the PORT group will keep its configuration.
1	The corresponding I/O pin output is driven low, or the input is connected to an internal pull-down.

## 29.7.7 Data Output Value Set

**Name:** OUTSET  
**Offset:** 0x18  
**Reset:** 0x00000000  
**Property:** PAC Write-Protection

This register allows the user to set one or more output I/O pin drive levels high, without doing a read-modify-write operation. Changes in this register will also be reflected in the Data Output Value (OUT), Data Output Value Toggle (OUTTGL) and Data Output Value Clear (OUTCLR) registers.



**Tip:** The I/O pins are assembled in pin groups (“PORT groups”) with up to 32 pins. Group 0 consists of the PA pins, group 1 is for the PB pins, etc. Each pin group has its own PORT registers, with a 0x80 address spacing. For example, the register address offset for the Data Direction (DIR) register for group 0 (PA00 to PA31) is 0x00, and the register address offset for the DIR register for group 1 (PB00 to PB31) is 0x80.

Bit	31	30	29	28	27	26	25	24
	OUTSET[31:24]							
Access	RW	RW	RW	RW	RW	RW	RW	RW
Reset	0	0	0	0	0	0	0	0
Bit	23	22	21	20	19	18	17	16
	OUTSET[23:16]							
Access	RW	RW	RW	RW	RW	RW	RW	RW
Reset	0	0	0	0	0	0	0	0
Bit	15	14	13	12	11	10	9	8
	OUTSET[15:8]							
Access	RW	RW	RW	RW	RW	RW	RW	RW
Reset	0	0	0	0	0	0	0	0
Bit	7	6	5	4	3	2	1	0
	OUTSET[7:0]							
Access	RW	RW	RW	RW	RW	RW	RW	RW
Reset	0	0	0	0	0	0	0	0

### Bits 31:0 – OUTSET[31:0] PORT Data Output Value Set

Writing '0' to a bit has no effect.

Writing '1' to a bit will set the corresponding bit in the OUT register, which sets the output drive level high for I/O pins configured as outputs via the Data Direction register (DIR). For pins configured as inputs via Data Direction register (DIR) with pull enabled via the Pull Enable register (PULLEN), these bits will set the input pull direction to an internal pull-up.

Value	Description
0	The corresponding I/O pin in the group will keep its configuration.
1	The corresponding I/O pin output is driven high, or the input is connected to an internal pull-up.

## 29.7.8 Data Output Value Toggle

**Name:** OUTTGL  
**Offset:** 0x1C  
**Reset:** 0x00000000  
**Property:** PAC Write-Protection

This register allows the user to toggle the drive level of one or more output I/O pins, without doing a read-modify-write operation. Changes in this register will also be reflected in the Data Output Value (OUT), Data Output Value Set (OUTSET) and Data Output Value Clear (OUTCLR) registers.



**Tip:** The I/O pins are assembled in pin groups (“PORT groups”) with up to 32 pins. Group 0 consists of the PA pins, group 1 is for the PB pins, etc. Each pin group has its own PORT registers, with a 0x80 address spacing. For example, the register address offset for the Data Direction (DIR) register for group 0 (PA00 to PA31) is 0x00, and the register address offset for the DIR register for group 1 (PB00 to PB31) is 0x80.

Bit	31	30	29	28	27	26	25	24
	OUTTGL[31:24]							
Access	RW	RW	RW	RW	RW	RW	RW	RW
Reset	0	0	0	0	0	0	0	0
Bit	23	22	21	20	19	18	17	16
	OUTTGL[23:16]							
Access	RW	RW	RW	RW	RW	RW	RW	RW
Reset	0	0	0	0	0	0	0	0
Bit	15	14	13	12	11	10	9	8
	OUTTGL[15:8]							
Access	RW	RW	RW	RW	RW	RW	RW	RW
Reset	0	0	0	0	0	0	0	0
Bit	7	6	5	4	3	2	1	0
	OUTTGL[7:0]							
Access	RW	RW	RW	RW	RW	RW	RW	RW
Reset	0	0	0	0	0	0	0	0

### Bits 31:0 – OUTTGL[31:0] PORT Data Output Value Toggle

Writing '0' to a bit has no effect.

Writing '1' to a bit will toggle the corresponding bit in the OUT register, which inverts the output drive level for I/O pins configured as outputs via the Data Direction register (DIR). For pins configured as inputs via Data Direction register (DIR) with pull enabled via the Pull Enable register (PULLEN), these bits will toggle the input pull direction.

Value	Description
0	The corresponding I/O pin in the PORT group will keep its configuration.
1	The corresponding OUT bit value is toggled.

## 29.7.9 Data Input Value

**Name:** IN  
**Offset:** 0x20  
**Reset:** 0x00000000  
**Property:** -



**Tip:** The I/O pins are assembled in pin groups (“PORT groups”) with up to 32 pins. Group 0 consists of the PA pins, group 1 is for the PB pins, etc. Each pin group has its own PORT registers, with a 0x80 address spacing. For example, the register address offset for the Data Direction (DIR) register for group 0 (PA00 to PA31) is 0x00, and the register address offset for the DIR register for group 1 (PB00 to PB31) is 0x80.

Bit	31	30	29	28	27	26	25	24
	IN[31:24]							
Access	R	R	R	R	R	R	R	R
Reset	0	0	0	0	0	0	0	0
Bit	23	22	21	20	19	18	17	16
	IN[23:16]							
Access	R	R	R	R	R	R	R	R
Reset	0	0	0	0	0	0	0	0
Bit	15	14	13	12	11	10	9	8
	IN[15:8]							
Access	R	R	R	R	R	R	R	R
Reset	0	0	0	0	0	0	0	0
Bit	7	6	5	4	3	2	1	0
	IN[7:0]							
Access	R	R	R	R	R	R	R	R
Reset	0	0	0	0	0	0	0	0

### Bits 31:0 – IN[31:0] PORT Data Input Value

These bits are cleared when the corresponding I/O pin input sampler detects a logical low level on the input pin.

These bits are set when the corresponding I/O pin input sampler detects a logical high level on the input pin.

## 29.7.10 Control

**Name:** CTRL  
**Offset:** 0x24  
**Reset:** 0x00000000  
**Property:** PAC Write-Protection



**Tip:** The I/O pins are assembled in pin groups (“PORT groups”) with up to 32 pins. Group 0 consists of the PA pins, group 1 is for the PB pins, etc. Each pin group has its own PORT registers, with a 0x80 address spacing. For example, the register address offset for the Data Direction (DIR) register for group 0 (PA00 to PA31) is 0x00, and the register address offset for the DIR register for group 1 (PB00 to PB31) is 0x80.

Bit	31	30	29	28	27	26	25	24
	SAMPLING[31:24]							
Access	RW	RW	RW	RW	RW	RW	RW	RW
Reset	0	0	0	0	0	0	0	0
Bit	23	22	21	20	19	18	17	16
	SAMPLING[23:16]							
Access	RW	RW	RW	RW	RW	RW	RW	RW
Reset	0	0	0	0	0	0	0	0
Bit	15	14	13	12	11	10	9	8
	SAMPLING[15:8]							
Access	RW	RW	RW	RW	RW	RW	RW	RW
Reset	0	0	0	0	0	0	0	0
Bit	7	6	5	4	3	2	1	0
	SAMPLING[7:0]							
Access	RW	RW	RW	RW	RW	RW	RW	RW
Reset	0	0	0	0	0	0	0	0

### Bits 31:0 – SAMPLING[31:0] Input Sampling Mode

Configures the input sampling functionality of the I/O pin input samplers, for pins configured as inputs via the Data Direction register (DIR).

The input samplers are enabled and disabled in sub-groups of eight. Thus if any pins within a byte request continuous sampling, all pins in that eight pin sub-group will be continuously sampled.

Value	Description
0	On demand sampling of I/O pin is enabled.
1	Continuous sampling of I/O pin is enabled.

## 29.7.11 Write Configuration

**Name:** WRCONFIG  
**Offset:** 0x28  
**Reset:** 0x00000000  
**Property:** PAC Write-Protection, Write-Only



**Tip:** The I/O pins are assembled in pin groups (“PORT groups”) with up to 32 pins. Group 0 consists of the PA pins, group 1 is for the PB pins, etc. Each pin group has its own PORT registers, with a 0x80 address spacing. For example, the register address offset for the Data Direction (DIR) register for group 0 (PA00 to PA31) is 0x00, and the register address offset for the DIR register for group 1 (PB00 to PB31) is 0x80.

This Write-only register is used to configure several pins simultaneously with the same configuration and peripheral multiplexing.

To avoid side effect of non-atomic access, 8-bit or 16-bit writes to this register will have no effect. Reading this register always returns zero.

Bit	31	30	29	28	27	26	25	24
	HWSEL	WRPINCFG		WRPMUX	PMUX[3:0]			
Access	W	W		W	W	W	W	W
Reset	0	0		0	0	0	0	0
Bit	23	22	21	20	19	18	17	16
		DRVSTR				PULLEN	INEN	PMUXEN
Access		W				W	W	W
Reset		0				0	0	0
Bit	15	14	13	12	11	10	9	8
	PINMASK[15:8]							
Access	W	W	W	W	W	W	W	W
Reset	0	0	0	0	0	0	0	0
Bit	7	6	5	4	3	2	1	0
	PINMASK[7:0]							
Access	W	W	W	W	W	W	W	W
Reset	0	0	0	0	0	0	0	0

### Bit 31 – HWSEL Half-Word Select

This bit selects the half-word field of a 32-PORT group to be reconfigured in the atomic write operation.

This bit will always read as zero.

Value	Description
0	The lower 16 pins of the PORT group will be configured.
1	The upper 16 pins of the PORT group will be configured.

### Bit 30 – WRPINCFG Write PINCFG

This bit determines whether the atomic write operation will update the Pin Configuration register (PINCFGy) or not for all pins selected by the WRCONFIG.PINMASK and WRCONFIG.HWSEL bits.

Writing '0' to this bit has no effect.



Writing '1' to this bit updates the configuration of the selected pins with the written WRCONFIG.DRVSTR, WRCONFIG.PULLEN, WRCONFIG.INEN, WRCONFIG.PMUXEN, and WRCONFIG.PINMASK values.

This bit will always read as zero.

Value	Description
0	The PINCFGy registers of the selected pins will not be updated.
1	The PINCFGy registers of the selected pins will be updated.

#### Bit 28 – WRPMUX Write PMUX

This bit determines whether the atomic write operation will update the Peripheral Multiplexing register (PMUXn) or not for all pins selected by the WRCONFIG.PINMASK and WRCONFIG.HWSEL bits. Writing '0' to this bit has no effect.

Writing '1' to this bit updates the pin multiplexer configuration of the selected pins with the written WRCONFIG.PMUX value.

This bit will always read as zero.

Value	Description
0	The PMUXn registers of the selected pins will not be updated.
1	The PMUXn registers of the selected pins will be updated.

#### Bits 27:24 – PMUX[3:0] Peripheral Multiplexing

These bits determine the new value written to the Peripheral Multiplexing register (PMUXn) for all pins selected by the WRCONFIG.PINMASK and WRCONFIG.HWSEL bits, when the WRCONFIG.WRPMUX bit is set.

These bits will always read as zero.

#### Bit 22 – DRVSTR Output Driver Strength Selection

This bit determines the new value written to PINCFGy.DRVSTR for all pins selected by the WRCONFIG.PINMASK and WRCONFIG.HWSEL bits, when the WRCONFIG.WRPINCFG bit is set.

This bit will always read as zero.

#### Bit 18 – PULLEN Pull Enable

This bit determines the new value written to PINCFGy.PULLEN for all pins selected by the WRCONFIG.PINMASK and WRCONFIG.HWSEL bits, when the WRCONFIG.WRPINCFG bit is set.

This bit will always read as zero.

#### Bit 17 – INEN Input Enable

This bit determines the new value written to PINCFGy.INEN for all pins selected by the WRCONFIG.PINMASK and WRCONFIG.HWSEL bits, when the WRCONFIG.WRPINCFG bit is set.

This bit will always read as zero.

#### Bit 16 – PMUXEN Peripheral Multiplexer Enable

This bit determines the new value written to PINCFGy.PMUXEN for all pins selected by the WRCONFIG.PINMASK and WRCONFIG.HWSEL bits, when the WRCONFIG.WRPINCFG bit is set.

This bit will always read as zero.

#### Bits 15:0 – PINMASK[15:0] Pin Mask for Multiple Pin Configuration

These bits select the pins to be configured within the half-word group selected by the WRCONFIG.HWSEL bit.

These bits will always read as zero.

Value	Description
0	The configuration of the corresponding I/O pin in the half-word group will be left unchanged.
1	The configuration of the corresponding I/O pin in the half-word PORT group will be updated.

## 29.7.12 Event Input Control

**Name:** EVCTRL  
**Offset:** 0x2C  
**Reset:** 0x00000000  
**Property:** PAC Write-Protection



**Tip:** The I/O pins are assembled in pin groups (“PORT groups”) with up to 32 pins. Group 0 consists of the PA pins, group 1 is for the PB pins, etc. Each pin group has its own PORT registers, with a 0x80 address spacing. For example, the register address offset for the Data Direction (DIR) register for group 0 (PA00 to PA31) is 0x00, and the register address offset for the DIR register for group 1 (PB00 to PB31) is 0x80.

For each PORT group, there are up to four input event pins: EVU0-3.

Each byte of this register addresses one Event input pin.

Bit	31	30	29	28	27	26	25	24
	PORTEI3	EVACT3[1:0]				PID3[4:0]		
Access	RW	RW	RW	RW	RW	RW	RW	RW
Reset	0	0	0	0	0	0	0	0
Bit	23	22	21	20	19	18	17	16
	PORTEI2	EVACT2[1:0]				PID2[4:0]		
Access	RW	RW	RW	RW	RW	RW	RW	RW
Reset	0	0	0	0	0	0	0	0
Bit	15	14	13	12	11	10	9	8
	PORTEI1	EVACT1[1:0]				PID1[4:0]		
Access	RW	RW	RW	RW	RW	RW	RW	RW
Reset	0	0	0	0	0	0	0	0
Bit	7	6	5	4	3	2	1	0
	PORTEI0	EVACT0[1:0]				PID0[4:0]		
Access	RW	RW	RW	RW	RW	RW	RW	RW
Reset	0	0	0	0	0	0	0	0

### Bits 7, 15, 23, 31 – PORTEIx PORT Event Input Enable x [x = 0..3]

Value	Description
0	The event action x (EVACTx) will not be triggered on any incoming event.
1	The event action x (EVACTx) will be triggered on any incoming event.

### Bits 5:6, 13:14, 21:22, 29:30 – EVACTx PORT Event Action x [x = 0..3]

These bits define the event action the PORT will perform on event input x. See *PORT Event x Action (x = [0..3])* for more information.

### Bits 0:4, 8:12, 16:20, 24:28 – PIDx PORT Event Pin Identifier x [x = 0..3]

These bits define the I/O pin on which the event action will be performed.

**Table 29-4.** PORT Event x Action ( x = [0..3] )

Value	Name	Description
0x0	OUT	Output register of pin will be set to level of event.

.....continued

Value	Name	Description
0x1	SET	Set output register of pin on event.
0x2	CLR	Clear output register of pin on event.
0x3	TGL	Toggle output register of pin on event.

**Table 29-5.** PORT Event x Pin Identifier ( x = [0..3] )

Value	Name	Description
0x0	PIN0	Event action to be executed on PIN 0.
0x1	PIN1	Event action to be executed on PIN 1.
...	...	...
0x31	PIN31	Event action to be executed on PIN 31.

## 29.7.13 Peripheral Multiplexing n

**Name:** PMUX  
**Offset:**  $0x30 + n \cdot 0x01$  [ $n=0..15$ ]  
**Reset:** 0x00  
**Property:** PAC Write-Protection



**Tip:** The I/O pins are assembled in pin groups (“PORT groups”) with up to 32 pins. Group 0 consists of the PA pins, group 1 is for the PB pins, etc. Each pin group has its own PORT registers, with a 0x80 address spacing. For example, the register address offset for the Data Direction (DIR) register for group 0 (PA00 to PA31) is 0x00, and the register address offset for the DIR register for group 1 (PB00 to PB31) is 0x80.

There are up to 16 Peripheral Multiplexing registers in each group, one for every set of two subsequent I/O lines. The ‘n’ denotes the number of the set of I/O lines.

Bit	7	6	5	4	3	2	1	0
	PMUXO[3:0]				PMUXE[3:0]			
Access	RW	RW	RW	RW	RW	RW	RW	RW
Reset	0	0	0	0	0	0	0	0

### Bits 7:4 – PMUXO[3:0] Peripheral Multiplexing for Odd-Numbered Pin

These bits select the peripheral function for odd-numbered pins ( $2 \cdot n + 1$ ) of a PORT group, if the corresponding PINCFGy.PMUXEN bit is '1'.

Not all possible values for this selection may be valid. For more details, refer to the [Pinout](#).

PMUXO[3:0]	Name	Description
0x0	A	Peripheral function A selected
0x1	B	Peripheral function B selected
0x2	C	Peripheral function C selected
0x3	D	Peripheral function D selected
0x4	E	Peripheral function E selected
0x5	F	Peripheral function F selected
0x6	G	Peripheral function G selected
0x7	H	Peripheral function H selected
0x8	I	Peripheral function I selected
0x9 - 0xF	-	Reserved

### Bits 3:0 – PMUXE[3:0] Peripheral Multiplexing for Even-Numbered Pin

These bits select the peripheral function for even-numbered pins ( $2 \cdot n$ ) of a PORT group, if the corresponding PINCFGy.PMUXEN bit is '1'.

Not all possible values for this selection may be valid. For more details, refer to the [Pinout](#).

PMUXE[3:0]	Name	Description
0x0	A	Peripheral function A selected
0x1	B	Peripheral function B selected
0x2	C	Peripheral function C selected
0x3	D	Peripheral function D selected
0x4	E	Peripheral function E selected
0x5	F	Peripheral function F selected
0x6	G	Peripheral function G selected
0x7	H	Peripheral function H selected
0x8	I	Peripheral function I selected

.....continued

PMUXE[3:0]	Name	Description
0x9 - 0xF	-	Reserved

## 29.7.14 Pin Configuration

**Name:** PINCFG  
**Offset:** 0x40 + n\*0x01 [n=0..31]  
**Reset:** 0x00  
**Property:** PAC Write-Protection



**Tip:** The I/O pins are assembled in pin groups (“PORT groups”) with up to 32 pins. Group 0 consists of the PA pins, group 1 is for the PB pins, etc. Each pin group has its own PORT registers, with a 0x80 address spacing. For example, the register address offset for the Data Direction (DIR) register for group 0 (PA00 to PA31) is 0x00, and the register address offset for the DIR register for group 1 (PB00 to PB31) is 0x80.

There are up to 32 Pin Configuration registers in each PORT group, one for each I/O line.

Bit	7	6	5	4	3	2	1	0
		DRVSTR				PULLEN	INEN	PMUXEN
Access		RW				RW	RW	RW
Reset		0				0	0	0

### Bit 6 – DRVSTR Output Driver Strength Selection

This bit controls the output driver strength of an I/O pin configured as an output.

Value	Description
0	Pin drive strength is set to normal drive strength.
1	Pin drive strength is set to stronger drive strength.

### Bit 2 – PULLEN Pull Enable

This bit enables the internal pull-up or pull-down resistor of an I/O pin configured as an input.

Value	Description
0	Internal pull resistor is disabled, and the input is in a high-impedance configuration.
1	Internal pull resistor is enabled, and the input is driven to a defined logic level in the absence of external input.

### Bit 1 – INEN Input Buffer Enable

This bit controls the input buffer of an I/O pin configured as either an input or output.

Writing a zero to this bit disables the input buffer completely, preventing read-back of the Physical Pin state when the pin is configured as either an input or output.

Value	Description
0	Input buffer for the I/O pin is disabled, and the input value will not be sampled.
1	Input buffer for the I/O pin is enabled, and the input value will be sampled when required.

### Bit 0 – PMUXEN Peripheral Multiplexer Enable

This bit enables or disables the peripheral multiplexer selection set in the Peripheral Multiplexing register (PMUXn) to enable or disable alternative peripheral control over an I/O pin direction and output drive value.

Writing a zero to this bit allows the PORT to control the pad direction via the Data Direction register (DIR) and output drive value via the Data Output Value register (OUT). The peripheral multiplexer value in PMUXn is ignored. Writing '1' to this bit enables the peripheral selection in PMUXn to control the pad. In this configuration, the Physical Pin state may still be read from the Data Input Value register (IN) if PINCFGn.INEN is set.

Value	Description
0	The peripheral multiplexer selection is disabled, and the PORT registers control the direction and output drive value.
1	The peripheral multiplexer selection is enabled, and the selected peripheral function controls the direction and output drive value.

## 30. Event System (EVSYS)

### 30.1 Overview

The Event System (EVSYS) allows autonomous, low-latency and configurable communication between peripherals.

Several peripherals can be configured to generate and/or respond to signals known as events. The exact condition to generate an event, or the action taken upon receiving an event, is specific to each peripheral. Peripherals that respond to events are called event users. Peripherals that generate events are called event generators. A peripheral can have one or more event generators and can have one or more event users.

Communication is made without CPU intervention and without consuming system resources, such as bus or RAM bandwidth. This reduces the load on the CPU and other system resources, compared to a traditional interrupt-based system.

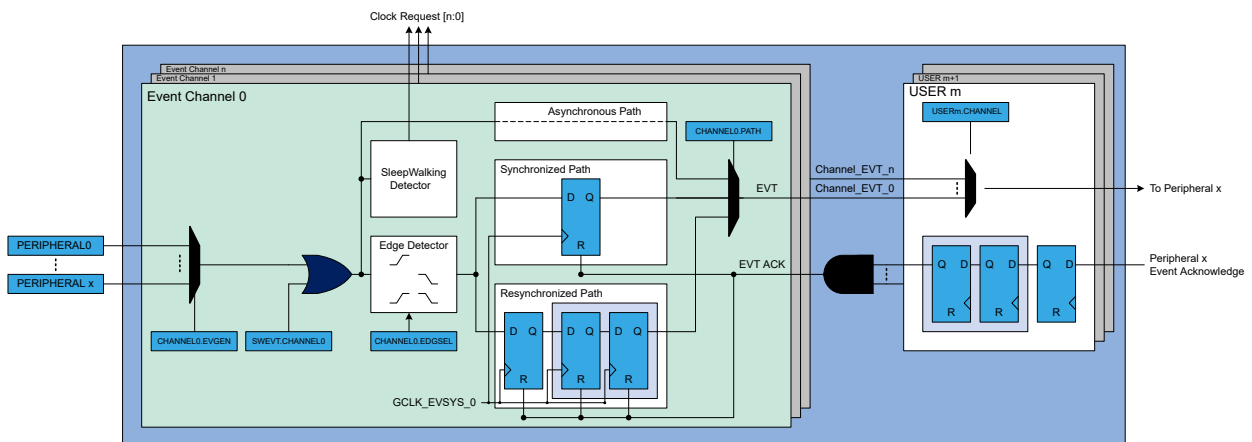
### 30.2 Features

The following are key features of the EVSYS:

- 32 configurable event channels:
  - All channels can be connected to any event generator
  - All channels provide a pure asynchronous path
  - 12 channels (CHANNEL0 to CHANNEL11) provide a resynchronized or synchronous path using their dedicated generic clock (GCLK\_EVSYS\_CHANNEL\_n)
- 119 event generators.
- 67 event users.
- Configurable edge detector.
- Peripherals can be event generators, event users, or both.
- SleepWalking and interrupt for operation in sleep modes.
- Software event generation.
- Each event user can choose which channel to respond to.
- Optional Static or Round-Robin interrupt priority arbitration.

### 30.3 Block Diagram

Figure 30-1. Event System Block Diagram



## 30.4 Peripheral Dependencies

<b>Peripheral Name</b>	EVSYS – Event System
<b>Base Address</b>	0x4100_E000 (Peripheral Bus B)
<b>NVIC IRQ Index:Source</b>	36 : EVD0, OVR0; 37 : EVD1, OVR1; 38 : EVD2, OVR2; 39 : EVD3, OVR3; 40 : EVD4..11; OVR4..11
<b>MCLK APB Clock (1)</b>	CLK_EVSYS_APB, Disabled, APBBMASK.EVSYS
<b>GCLK Peripheral Channel Index:Clock Name (2)</b>	11-22 : GCLK_EVSYS_CHx, x=0,1,...11
<b>PAC Peripheral Identifier (PAC.WRCTRL)</b>	39
<b>Notes:</b>	
	<ol style="list-style-type: none"> <li>1. Clock Name, Default State, Mask Field.</li> <li>2. See GCLK.PCHCTRLm Register, where m = Index.</li> </ol>

### 30.4.1 Power Management

The EVSYS can be used to wake up the CPU from all sleep modes (except BACKUP and OFF Mode), even if the clock used by the EVSYS channel and the EVSYS bus clock are disabled. Refer to the [PM – Power Manager](#) for details on the different sleep modes.

Although the clock for the EVSYS is stopped, the device still can wake up the EVSYS clock. Some event generators can generate an event when their clocks are stopped. The generic clock for the channel (GCLK\_EVSYS\_CHANNEL\_n) will be restarted if that channel uses a synchronized path or a resynchronized path. It does not need to wake the system from sleep.



**Important:** This generic clock only applies to channels which can be configured as synchronous or resynchronized.

### 30.4.2 Clocks

The EVSYS bus clock (CLK\_EVSYS\_APB) can be enabled and disabled in the [Main Clock module](#), and the default state of CLK\_EVSYS\_APB can be found in [Peripheral Clock Masking](#).

Each EVSYS channel which can be configured as synchronous or resynchronized has a dedicated generic clock (GCLK\_EVSYS\_CHANNEL\_n). These are used for event detection and propagation for each channel. These clocks must be configured and enabled in the generic clock controller before using the EVSYS. Refer to [GCLK - Generic Clock Controller](#) for details.



**Important:** Only EVSYS channel 0 to 11 can be configured as synchronous or resynchronized.

### 30.4.3 Debug Operation

When the CPU is halted in Debug mode, this peripheral will continue normal operation. If the peripheral is configured to require periodical service by the CPU through interrupts or similar, improper operation or data loss may result during debugging. This peripheral can be forced to halt operation during debugging.

### 30.4.4 Register Access Protection

Registers with write access can be optionally write-protected by the [Peripheral Access Controller \(PAC\)](#), except for the following:

- Interrupt Flag (INTFLAG) register



- Channel Pending Interrupt (INTPEND)
- Channel n Interrupt Flag Status and Clear (CHINTFLAGn)

**Note:** Optional write protection is indicated by the "PAC Write Protection" property in the register description.

Write protection does not apply for accesses through an external debugger.

## 30.5 Functional Description

### 30.5.1 Principle of Operation

The Event System consists of several channels which route the internal events from peripherals (generators) to other internal peripherals or I/O pins (users). Each event generator can be selected as source for multiple channels, but a channel cannot be set to use multiple event generators at the same time.

A channel path can be configured in asynchronous, synchronous or resynchronized mode of operation. The mode of operation must be selected based on the requirements of the application.

When using synchronous or resynchronized path, the Event System includes options to transfer events to users when rising, falling or both edges are detected on event generators.

For further details, refer to the [Channel Path](#) section of this chapter.

### 30.5.2 Basic Operation

#### 30.5.2.1 Initialization

Before enabling event routing within the system, the Event Users Multiplexer and Event Channels must be selected in the Event System (EVSYS), and the two peripherals that generate and use the event must be configured. Follow these steps to configure the event:

1. In the peripheral generating the event, enable output of event by writing a '1' to the respective Event Output Enable bit ("EO") in the peripheral's Event Control register, for example, AC.EVCTRL.WINEO0 or RTC.EVCTRL.OVFEO.
  2. Configure the EVSYS:
    - a. Configure the Event User multiplexer by writing the respective EVSYS.USERm register, refer to [30.5.2.3. User Multiplexer Setup](#).
    - b. Configure the Event Channel by writing the respective EVSYS.CHANNELn register, refer to [30.5.2.4. Event System Channel](#).
  3. Configure the action to be executed by the event user peripheral by writing to the Event Action bits (EACT) in the respective Event control register, for example, TC.EVCTRL.EACT, PDEC.EVCTRL.EACT.
- Note:** This step is not applicable for all the peripherals.
4. In the event user peripheral, enable event input by writing a '1' to the respective Event Input Enable bit ("EI") in the peripheral's Event Control register, for example, AC.EVCTRL.IVEI0, ADC.EVCTRL.STARTEI.

#### 30.5.2.2 Enabling, Disabling, and Resetting

The EVSYS is always enabled.

The EVSYS is reset by writing a '1' to the Software Reset bit in the Control A register (CTRLA.SWRST). All registers in the EVSYS will be reset to their initial state and all ongoing events will be canceled.

Refer to [CTRLA.SWRST](#) register for details.

#### 30.5.2.3 User Multiplexer Setup

The user multiplexer defines the channel to be connected to which event user. Each user multiplexer is dedicated to one event user. A user multiplexer receives all event channels output and must

be configured to select one of these channels, as shown in [Block Diagram](#) section. The channel is selected with the Channel bit group in the User register (`USERm.CHANNEL`).

The user multiplexer must always be configured before the channel. A list of all available event users is found in the User (`USERm`) register description.

### 30.5.2.4 Event System Channel

An event channel can select one event from a list of event generators. Depending on configuration, the selected event could be synchronized, resynchronized or asynchronously sent to the users. When synchronization or resynchronization is required, the channel includes an internal edge detector, allowing the Event System to generate internal events when rising, falling or both edges are detected on the selected event generator.

An event channel is able to generate internal events for the specific software commands. A channel block diagram is shown in [Block Diagram](#) section.

### 30.5.2.5 Event Generators

Each event channel can receive the events from all event generators. All event generators are listed in the Event Generator bit field in the Channel n register (`CHANNELn.EVGEN`). For details on event generation, refer to the corresponding module chapter. The channel event generator is selected by the Event Generator bit group in the Channel register (`CHANNELn.EVGEN`). By default, the channels are not connected to any event generators (ie, `CHANNELn.EVGEN = 0`)

### 30.5.2.6 Channel Path

There are different ways to propagate the event from an event generator:

- Asynchronous path
- Synchronous path
- Resynchronized path

The path is decided by writing to the Path Selection bit group of the Channel register (`CHANNELn.PATH`).



**Important:** In both Synchronous and Resynchronized paths, the EVSYS must be write protected by configuring the `WRCTRL` register in the PAC before being used to avoid any spurious event detections that may happen when accessing peripherals used in conjunction with the EVSYS.

#### Asynchronous Path

When using the asynchronous path, the events are propagated from the event generator to the event user without intervention from the Event System. The `GCLK` for this channel (`GCLK_EVSYS_CHANNEL_n`) is not mandatory, meaning that an event will be propagated to the user without any clock latency.

When the asynchronous path is selected, the channel cannot generate any interrupts, and the Channel x Status register (`CHSTATUSx`) is always zero. The edge detection is not required and must be disabled by software. Each peripheral event user has to select which event edge must trigger internal actions. For further details, refer to each peripheral chapter description.

#### Synchronous Path

The synchronous path should be used when the event generator and the event channel share the same generator for the generic clock. If they do not share the same clock, a logic change from the event generator to the event channel might not be detected in the channel, which means that the event will not be propagated to the event user.

When using the synchronous path, the channel is able to generate interrupts. The channel status bits in the Channel Status register (`CHSTATUS`) are also updated and available for use.

### Resynchronized Path

The resynchronized path are used when the event generator and the event channel do not share the same generator for the generic clock. When the resynchronized path is used, resynchronization of the event from the event generator is done in the channel.

When the resynchronized path is used, the channel is able to generate interrupts. The channel status bits in the Channel Status register (CHSTATUS) are also updated and available for use.

#### 30.5.2.7 Edge Detection

When synchronous or resynchronized paths are used, edge detection must be enabled. The event system can execute edge detection in three different ways:

- Generate an event only on the rising edge
- Generate an event only on the falling edge
- Generate an event on rising and falling edges.

Edge detection is selected by writing to the Edge Selection bit group of the Channel register (CHANNELn.EDGSEL).

#### 30.5.2.8 Event Latency

The latency from event generator to event user depends on the channel's configuration:

- Asynchronous Path: The maximum routing latency of an external event is related to the internal signal routing and it is device dependent.
- Synchronous Path: The maximum routing latency of an external event is one GCLK\_EVSYS\_CHANNEL\_n clock cycle.
- Resynchronized Path: The maximum routing latency of an external event is three GCLK\_EVSYS\_CHANNEL\_n clock cycles.

The maximum propagation latency of a user event to the peripheral clock core domain is three peripheral clock cycles.

The event generators, event channel and event user clocks ratio must be selected in relation with the internal event latency constraints. Events propagation or event actions in peripherals may be lost if the clock setup violates the internal latencies.

#### 30.5.2.9 The Overrun Channel n Interrupt

The Overrun Channel n Interrupt flag in the Interrupt Flag Status and Clear register (INTFLAGn.OVR) will be set, and the optional interrupt will be generated in the following cases:

- One or more event users on channel n is not ready when there is a new event
- An event occurs when the previous event on channel m has not been handled by all event users connected to that channel

The flag will only be set when using synchronous or resynchronized paths. In the case of asynchronous path, the INTFLAGn.OVR is always read as zero.

#### 30.5.2.10 The Event Detected Channel n Interrupt

The Event Detected Channel n Interrupt flag in the Interrupt Flag Status and Clear register (INTFLAGn.EVD) is set when an event coming from the event generator configured on channel n is detected.

The flag will only be set when using a synchronous or resynchronized path. In the case of an asynchronous path, the INTFLAGn.EVD is always zero.

#### 30.5.2.11 Channel Status

The Channel Status register (CHSTATUS) shows the status of the channels when using a synchronous or resynchronized path. There are two different status bits in CHSTATUS for each of the available channels:

- The CHSTATUSn.BUSYCH bit will be set when an event on the corresponding channel n has not been handled by all event users connected to that channel.
- The CHSTATUSn.RDYUSR bit will be set when all event users connected to the corresponding channel are ready to handle incoming events on that channel.

### 30.5.2.12 Software Event

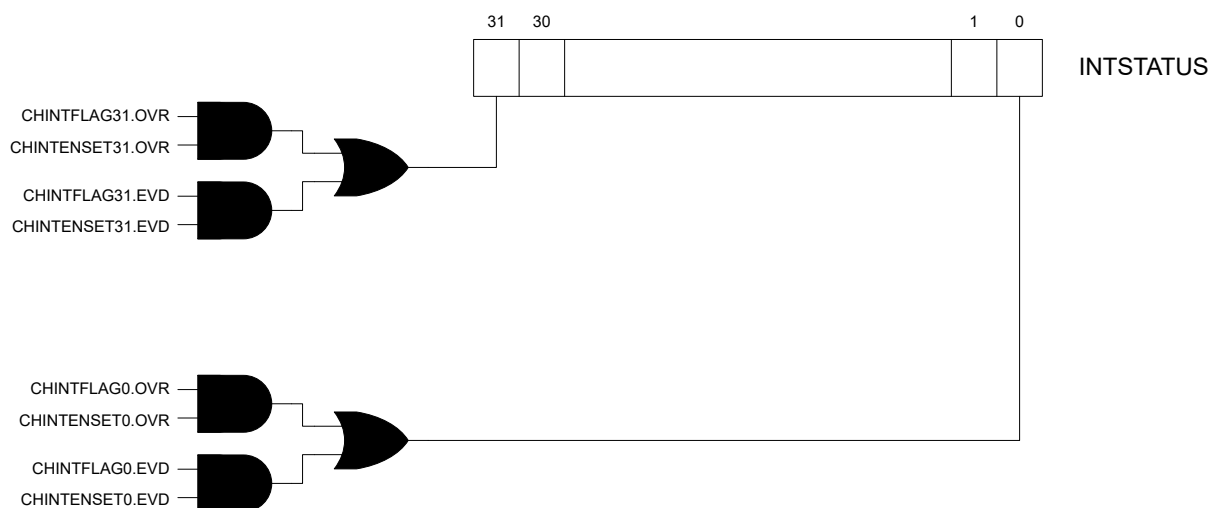
A software event can be initiated on a channel by writing a '1' to the Software Event bit in the Channel register (SWEVT.CHANNELn). Then the software event can be serviced as any event generator; i.e., when a bit is set to '1', the corresponding event will be generated on the respective channel.

**Note:** Software Events are only supported in Asynchronous mode.

### 30.5.2.13 Interrupt Status and Interrupts Arbitration

The Interrupt Status register stores all channels with pending interrupts, as shown below.

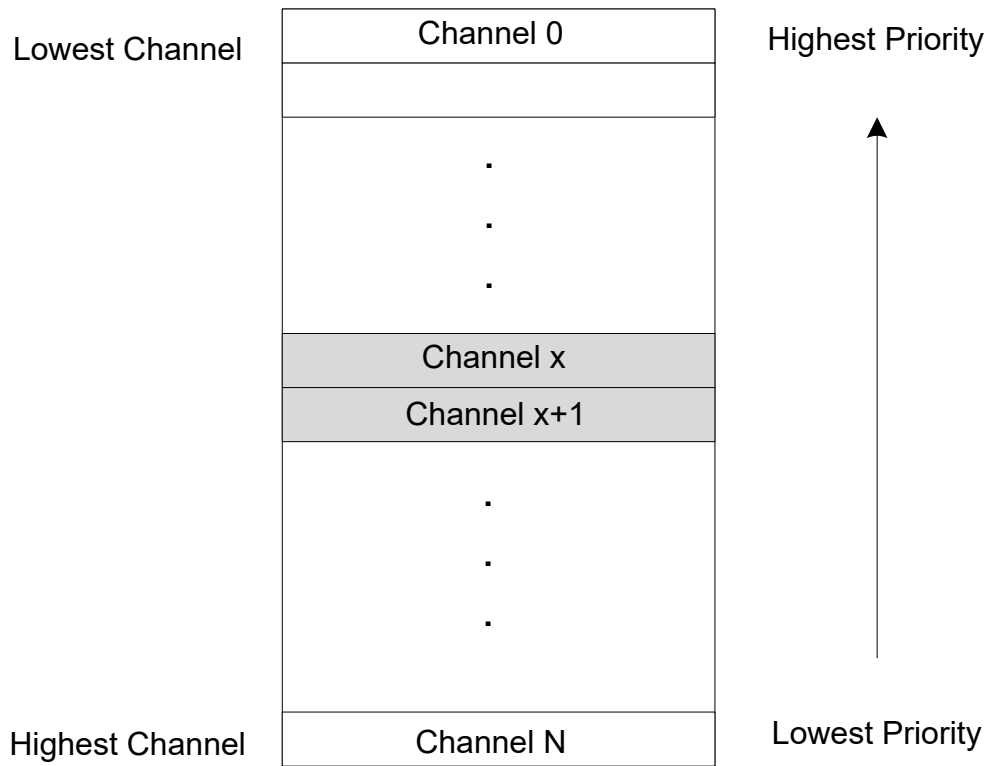
**Figure 30-2.** Interrupt Status Register



The Event System can arbitrate between all channels with pending interrupts. The arbiter can be configured to prioritize statically or dynamically the incoming events. The priority is evaluated each time a new channel has an interrupt pending, or an interrupt has been cleared. The Channel Pending Interrupt register (INTPEND) will provide the channel number with the highest interrupt priority, and the corresponding channel interrupt flags and status bits.

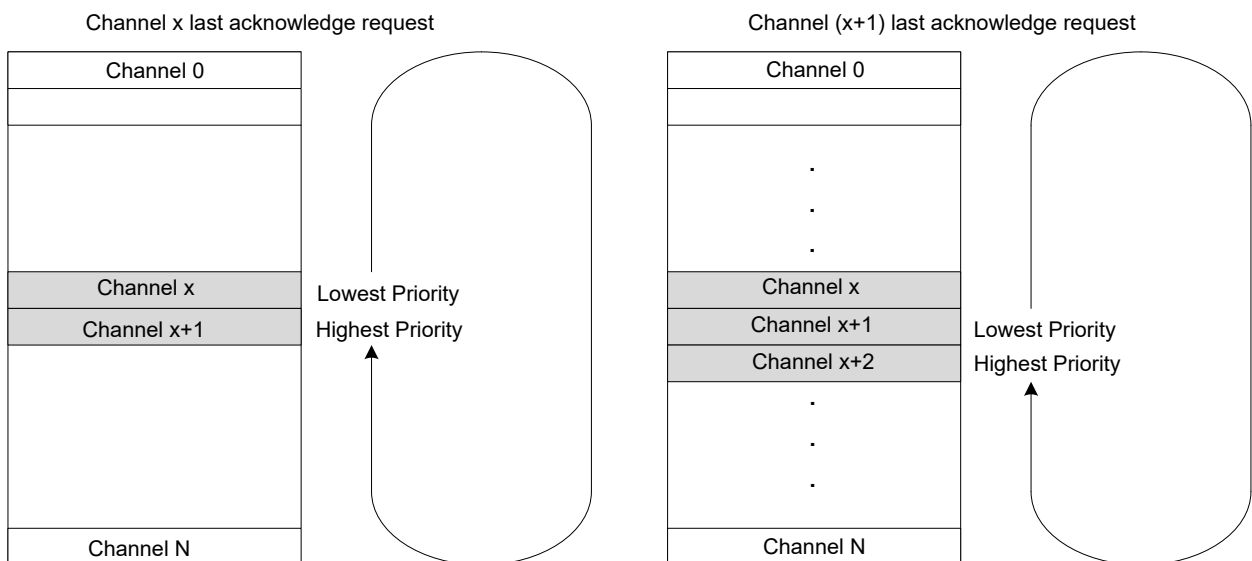
By default, static arbitration is enabled (PRICTRL.RRENx is '0'), the arbiter will prioritize a low channel number over a high channel number as shown below. When using the status scheme, there is a risk of high channel numbers never being granted access by the arbiter. This can be avoided using a dynamic arbitration scheme.

**Figure 30-3.** Static Priority



The dynamic arbitration scheme available in the Event System is round-robin. Round-robin arbitration is enabled by writing `PRICTRL.RREN` to one. With the round-robin scheme, the channel number of the last channel being granted access will have the lowest priority the next time the arbiter has to grant access to a channel, as shown below. The channel number of the last channel being granted access, will be stored in the Channel Priority Number bit group in the Priority Control register (`PRICTRL.PRI`).

**Figure 30-4.** Round-Robin Scheduling



The Channel Pending Interrupt register (INTPEND) also offers the possibility to indirectly clear the interrupt flags of a specific channel. Writing a flag to one in this register, will clear the corresponding interrupt flag of the channel specified by the INTPEND.ID bits.

### 30.5.3 Interrupts

The EVSYS has the following interrupt sources for each channel:

- Overrun Channel n interrupt (OVR)
- Event Detected Channel n interrupt (EVD)

These interrupts events are asynchronous wake-up sources.

Each interrupt source has an interrupt flag associated with it. The interrupt flag in the corresponding Channel n Interrupt Flag Status and Clear (CHINTFLAG) register is set when the interrupt condition occurs.

**Note:** Interrupts must be globally enabled to allow the generation of interrupt requests.

Each interrupt can be individually enabled by writing a '1' to the corresponding bit in the Channel n Interrupt Enable Set (CHINTENSET) register, and disabled by writing a '1' to the corresponding bit in the Channel n Interrupt Enable Clear (CHINTENCLR) register. An interrupt request is generated when the interrupt flag is set and the corresponding interrupt is enabled. The interrupt request remains active until the interrupt flag is cleared, the interrupt is disabled or the Event System is reset. All interrupt requests are ORed together on system level to generate one combined interrupt request to the NVIC.

The user must read the Channel Interrupt Status (INTSTATUS) register to identify the channels with pending interrupts, and must read the Channel n Interrupt Flag Status and Clear (CHINTFLAG) register to determine which interrupt condition is present for the corresponding channel. It is also possible to read the Interrupt Pending register (INTPEND), which provides the highest priority channel with pending interrupt and the respective interrupt flags.

### 30.5.4 Sleep Mode Operation

The Event System can generate interrupts to wake up the device from IDLE or STANDBY sleep mode.

To be able to run in standby, the Run in Standby bit in the Channel register (CHANNELn.RUNSTDBY) must be set to '1'. When the Generic Clock On Demand bit in Channel register (CHANNELn.ONDEMAND) is set to '1' and the event generator is detected, the event channel will request its clock (GCLK\_EVSYS\_CHANNEL\_n). The event latency for a resynchronized channel path will increase by two GCLK\_EVSYS\_CHANNEL\_n clock (i.e., up to five GCLK\_EVSYS\_CHANNEL\_n clock cycles).

A channel will behave differently in different sleep modes regarding to CHANNELn.RUNSTDBY and CHANNELn.ONDEMAND:

**Table 30-1.** Event Channel Sleep Behavior

CHANNELn.PATH	CHANNELn.ONDEMAND	CHANNELn.RUNSTDBY	Sleep Behavior
ASYN	0	0	Only run in IDLE sleep modes if an event must be propagated. Disabled in STANDBY sleep mode.
RESYN	0	1	Run in both IDLE and STANDBY sleep modes.
SYN/RESYN	1	0	Only run in IDLE sleep modes if an event must be propagated. Disabled in STANDBY sleep mode. Two GCLK_EVSYS_n latency added in RESYN path before the event is propagated internally.
SYN/RESYN	1	1	Run in both IDLE and STANDBY sleep modes. Two GCLK_EVSYS_n latency added in RESYN path before the event is propagated internally.

**Note:** In Synchronous mode, it is mandatory to enable the Generic Clock On Demand feature (CHANNELn.ONDEMAND=1).

## 30.6 Register Summary

Offset	Name	Bit Pos.	7	6	5	4	3	2	1	0
0x00	<a href="#">CTRLA</a>	7:0								SWRST
0x01	Reserved									
...										
0x03										
0x04	<a href="#">SWEVT</a>	7:0	CHANNEL7	CHANNEL6	CHANNEL5	CHANNEL4	CHANNEL3	CHANNEL2	CHANNEL1	CHANNEL0
		15:8	CHANNEL15	CHANNEL14	CHANNEL13	CHANNEL12	CHANNEL11	CHANNEL10	CHANNEL9	CHANNEL8
		23:16	CHANNEL23	CHANNEL22	CHANNEL21	CHANNEL20	CHANNEL19	CHANNEL18	CHANNEL17	CHANNEL16
		31:24	CHANNEL31	CHANNEL30	CHANNEL29	CHANNEL28	CHANNEL27	CHANNEL26	CHANNEL25	CHANNEL24
0x08	<a href="#">PRICTRL</a>	7:0	RREN					PRI[3:0]		
0x09	Reserved									
...										
0x0F										
0x10	<a href="#">INTPEND</a>	7:0					ID[3:0]			
		15:8	BUSY	READY					EVD	OVR
0x12	Reserved									
...										
0x13										
0x14	<a href="#">INTSTATUS</a>	7:0	CHINT7	CHINT6	CHINT5	CHINT4	CHINT3	CHINT2	CHINT1	CHINT0
		15:8					CHINT11	CHINT10	CHINT9	CHINT8
		23:16								
		31:24								
0x18	<a href="#">BUSYCH</a>	7:0	BUSYCH7	BUSYCH6	BUSYCH5	BUSYCH4	BUSYCH3	BUSYCH2	BUSYCH1	BUSYCH0
		15:8					BUSYCH11	BUSYCH10	BUSYCH9	BUSYCH8
		23:16								
		31:24								
0x1C	<a href="#">READYUSR</a>	7:0	READYUSR7	READYUSR6	READYUSR5	READYUSR4	READYUSR3	READYUSR2	READYUSR1	READYUSR0
		15:8					READYUSR11	READYUSR10	READYUSR9	READYUSR8
		23:16								
		31:24								
0x20	<a href="#">CHANNEL0</a>	7:0					EVGEN[6:0]			
		15:8	ONDEMAND	RUNSTDBY			EDGSEL[1:0]		PATH[1:0]	
		23:16								
		31:24								
0x24	<a href="#">CHINTENCLR0</a>	7:0						EVD	OVR	
0x25	<a href="#">CHINTENSET0</a>	7:0						EVD	OVR	
0x26	<a href="#">CHINTFLAG0</a>	7:0						EVD	OVR	
0x27	<a href="#">CHSTATUS0</a>	7:0						BUSYCH	RDYUSR	
0x28	<a href="#">CHANNEL1</a>	7:0					EVGEN[6:0]			
		15:8	ONDEMAND	RUNSTDBY			EDGSEL[1:0]		PATH[1:0]	
		23:16								
		31:24								
0x2C	<a href="#">CHINTENCLR1</a>	7:0						EVD	OVR	
0x2D	<a href="#">CHINTENSET1</a>	7:0						EVD	OVR	
0x2E	<a href="#">CHINTFLAG1</a>	7:0						EVD	OVR	
0x2F	<a href="#">CHSTATUS1</a>	7:0						BUSYCH	RDYUSR	
0x30	<a href="#">CHANNEL2</a>	7:0					EVGEN[6:0]			
		15:8	ONDEMAND	RUNSTDBY			EDGSEL[1:0]		PATH[1:0]	
		23:16								
		31:24								
0x34	<a href="#">CHINTENCLR2</a>	7:0						EVD	OVR	
0x35	<a href="#">CHINTENSET2</a>	7:0						EVD	OVR	
0x36	<a href="#">CHINTFLAG2</a>	7:0						EVD	OVR	
0x37	<a href="#">CHSTATUS2</a>	7:0						BUSYCH	RDYUSR	
0x38	<a href="#">CHANNEL3</a>	7:0					EVGEN[6:0]			
		15:8	ONDEMAND	RUNSTDBY			EDGSEL[1:0]		PATH[1:0]	
		23:16								
		31:24								
0x3C	<a href="#">CHINTENCLR3</a>	7:0						EVD	OVR	
0x3D	<a href="#">CHINTENSET3</a>	7:0						EVD	OVR	



.....continued											
Offset	Name	Bit Pos.	7	6	5	4	3	2	1	0	
0x3E	CHINTFLAG3	7:0							EVD	OVR	
0x3F	CHSTATUS3	7:0							BUSYCH	RDYUSR	
0x40	CHANNEL4	7:0									
		15:8	ONDEMAND	RUNSTDBY				EVGEN[6:0]		EDGSEL[1:0]	PATH[1:0]
		23:16									
		31:24									
0x44	CHINTENCLR4	7:0						EVD	OVR		
0x45	CHINTENSET4	7:0						EVD	OVR		
0x46	CHINTFLAG4	7:0						EVD	OVR		
0x47	CHSTATUS4	7:0						BUSYCH	RDYUSR		
0x48	CHANNEL5	7:0									
		15:8	ONDEMAND	RUNSTDBY				EVGEN[6:0]		EDGSEL[1:0]	PATH[1:0]
		23:16									
		31:24									
0x4C	CHINTENCLR5	7:0						EVD	OVR		
0x4D	CHINTENSET5	7:0						EVD	OVR		
0x4E	CHINTFLAG5	7:0						EVD	OVR		
0x4F	CHSTATUS5	7:0						BUSYCH	RDYUSR		
0x50	CHANNEL6	7:0									
		15:8	ONDEMAND	RUNSTDBY				EVGEN[6:0]		EDGSEL[1:0]	PATH[1:0]
		23:16									
		31:24									
0x54	CHINTENCLR6	7:0						EVD	OVR		
0x55	CHINTENSET6	7:0						EVD	OVR		
0x56	CHINTFLAG6	7:0						EVD	OVR		
0x57	CHSTATUS6	7:0						BUSYCH	RDYUSR		
0x58	CHANNEL7	7:0									
		15:8	ONDEMAND	RUNSTDBY				EVGEN[6:0]		EDGSEL[1:0]	PATH[1:0]
		23:16									
		31:24									
0x5C	CHINTENCLR7	7:0						EVD	OVR		
0x5D	CHINTENSET7	7:0						EVD	OVR		
0x5E	CHINTFLAG7	7:0						EVD	OVR		
0x5F	CHSTATUS7	7:0						BUSYCH	RDYUSR		
0x60	CHANNEL8	7:0									
		15:8	ONDEMAND	RUNSTDBY				EVGEN[6:0]		EDGSEL[1:0]	PATH[1:0]
		23:16									
		31:24									
0x64	CHINTENCLR8	7:0						EVD	OVR		
0x65	CHINTENSET8	7:0						EVD	OVR		
0x66	CHINTFLAG8	7:0						EVD	OVR		
0x67	CHSTATUS8	7:0						BUSYCH	RDYUSR		
0x68	CHANNEL9	7:0									
		15:8	ONDEMAND	RUNSTDBY				EVGEN[6:0]		EDGSEL[1:0]	PATH[1:0]
		23:16									
		31:24									
0x6C	CHINTENCLR9	7:0						EVD	OVR		
0x6D	CHINTENSET9	7:0						EVD	OVR		
0x6E	CHINTFLAG9	7:0						EVD	OVR		
0x6F	CHSTATUS9	7:0						BUSYCH	RDYUSR		
0x70	CHANNEL10	7:0									
		15:8	ONDEMAND	RUNSTDBY				EVGEN[6:0]		EDGSEL[1:0]	PATH[1:0]
		23:16									
		31:24									
0x74	CHINTENCLR10	7:0						EVD	OVR		
0x75	CHINTENSET10	7:0						EVD	OVR		
0x76	CHINTFLAG10	7:0						EVD	OVR		
0x77	CHSTATUS10	7:0						BUSYCH	RDYUSR		

.....continued

Offset	Name	Bit Pos.	7	6	5	4	3	2	1	0
0x78	CHANNEL11	7:0	EVGEN[6:0]							
		15:8	ONDEMAND	RUNSTDBY				EDGSEL[1:0]	PATH[1:0]	
		23:16								
		31:24								
0x7C	CHINTENCLR11	7:0							EVD	OVR
0x7D	CHINTENSET11	7:0							EVD	OVR
0x7E	CHINTFLAG11	7:0							EVD	OVR
0x7F	CHSTATUS11	7:0							BUSYCH	RDYUSR
0x80	CHANNEL12	7:0	EVGEN[6:0]							
		15:8	ONDEMAND	RUNSTDBY				EDGSEL[1:0]	PATH[1:0]	
		23:16								
		31:24								
0x84 ... 0x87	Reserved									
0x88	CHANNEL13	7:0	EVGEN[6:0]							
		15:8	ONDEMAND	RUNSTDBY				EDGSEL[1:0]	PATH[1:0]	
		23:16								
		31:24								
0x8C ... 0x8F	Reserved									
0x90	CHANNEL14	7:0	EVGEN[6:0]							
		15:8	ONDEMAND	RUNSTDBY				EDGSEL[1:0]	PATH[1:0]	
		23:16								
		31:24								
0x94 ... 0x97	Reserved									
0x98	CHANNEL15	7:0	EVGEN[6:0]							
		15:8	ONDEMAND	RUNSTDBY				EDGSEL[1:0]	PATH[1:0]	
		23:16								
		31:24								
0x9C ... 0x9F	Reserved									
0xA0	CHANNEL16	7:0	EVGEN[6:0]							
		15:8	ONDEMAND	RUNSTDBY				EDGSEL[1:0]	PATH[1:0]	
		23:16								
		31:24								
0xA4 ... 0xA7	Reserved									
0xA8	CHANNEL17	7:0	EVGEN[6:0]							
		15:8	ONDEMAND	RUNSTDBY				EDGSEL[1:0]	PATH[1:0]	
		23:16								
		31:24								
0xAC ... 0xAF	Reserved									
0xB0	CHANNEL18	7:0	EVGEN[6:0]							
		15:8	ONDEMAND	RUNSTDBY				EDGSEL[1:0]	PATH[1:0]	
		23:16								
		31:24								
0xB4 ... 0xB7	Reserved									
0xB8	CHANNEL19	7:0	EVGEN[6:0]							
		15:8	ONDEMAND	RUNSTDBY				EDGSEL[1:0]	PATH[1:0]	
		23:16								
		31:24								

.....continued

Offset	Name	Bit Pos.	7	6	5	4	3	2	1	0
0xBC ... 0xBF	Reserved									
0xC0	CHANNEL20	7:0					EVGEN[6:0]			
		15:8	ONDEMAND	RUNSTDBY			EDGSEL[1:0]		PATH[1:0]	
		23:16								
		31:24								
0xC4 ... 0xC7	Reserved									
0xC8	CHANNEL21	7:0					EVGEN[6:0]			
		15:8	ONDEMAND	RUNSTDBY			EDGSEL[1:0]		PATH[1:0]	
		23:16								
		31:24								
0xCC ... 0xCF	Reserved									
0xD0	CHANNEL22	7:0					EVGEN[6:0]			
		15:8	ONDEMAND	RUNSTDBY			EDGSEL[1:0]		PATH[1:0]	
		23:16								
		31:24								
0xD4 ... 0xD7	Reserved									
0xD8	CHANNEL23	7:0					EVGEN[6:0]			
		15:8	ONDEMAND	RUNSTDBY			EDGSEL[1:0]		PATH[1:0]	
		23:16								
		31:24								
0xDC ... 0xDF	Reserved									
0xE0	CHANNEL24	7:0					EVGEN[6:0]			
		15:8	ONDEMAND	RUNSTDBY			EDGSEL[1:0]		PATH[1:0]	
		23:16								
		31:24								
0xE4 ... 0xE7	Reserved									
0xE8	CHANNEL25	7:0					EVGEN[6:0]			
		15:8	ONDEMAND	RUNSTDBY			EDGSEL[1:0]		PATH[1:0]	
		23:16								
		31:24								
0xEC ... 0xEF	Reserved									
0xF0	CHANNEL26	7:0					EVGEN[6:0]			
		15:8	ONDEMAND	RUNSTDBY			EDGSEL[1:0]		PATH[1:0]	
		23:16								
		31:24								
0xF4 ... 0xF7	Reserved									
0xF8	CHANNEL27	7:0					EVGEN[6:0]			
		15:8	ONDEMAND	RUNSTDBY			EDGSEL[1:0]		PATH[1:0]	
		23:16								
		31:24								
0xFC ... 0xFF	Reserved									

.....continued

Offset	Name	Bit Pos.	7	6	5	4	3	2	1	0
0x0100	CHANNEL28	7:0					EVGEN[6:0]			
		15:8	ONDEMAND	RUNSTDBY			EDGSEL[1:0]		PATH[1:0]	
		23:16								
		31:24								
0x0104 ... 0x0107	Reserved									
0x0108	CHANNEL29	7:0					EVGEN[6:0]			
		15:8	ONDEMAND	RUNSTDBY			EDGSEL[1:0]		PATH[1:0]	
		23:16								
		31:24								
0x010C ... 0x010F	Reserved									
0x0110	CHANNEL30	7:0					EVGEN[6:0]			
		15:8	ONDEMAND	RUNSTDBY			EDGSEL[1:0]		PATH[1:0]	
		23:16								
		31:24								
0x0114 ... 0x0117	Reserved									
0x0118	CHANNEL31	7:0					EVGEN[6:0]			
		15:8	ONDEMAND	RUNSTDBY			EDGSEL[1:0]		PATH[1:0]	
		23:16								
		31:24								
0x011C ... 0x011F	Reserved									
0x0120	USER0	7:0				CHANNEL[5:0]				
0x0121 ... 0x0123	Reserved									
0x0124	USER1	7:0				CHANNEL[5:0]				
0x0125 ... 0x0127	Reserved									
0x0128	USER2	7:0				CHANNEL[5:0]				
0x0129 ... 0x012B	Reserved									
0x012C	USER3	7:0				CHANNEL[5:0]				
0x012D ... 0x012F	Reserved									
0x0130	USER4	7:0				CHANNEL[5:0]				
0x0131 ... 0x0133	Reserved									
0x0134	USER5	7:0				CHANNEL[5:0]				
0x0135 ... 0x0137	Reserved									
0x0138	USER6	7:0				CHANNEL[5:0]				
0x0139 ... 0x013B	Reserved									
0x013C	USER7	7:0				CHANNEL[5:0]				
0x013D ... 0x013F	Reserved									
0x0140	USER8	7:0				CHANNEL[5:0]				

.....continued

Offset	Name	Bit Pos.	7	6	5	4	3	2	1	0
0x0141	Reserved									
...										
0x0143										
0x0144	USER9	7:0								
0x0145										
...	Reserved									
0x0147										
0x0148	USER10	7:0								
0x0149										
...	Reserved									
0x014B										
0x014C	USER11	7:0								
0x014D										
...	Reserved									
0x014F										
0x0150	USER12	7:0								
0x0151										
...	Reserved									
0x0153										
0x0154	USER13	7:0								
0x0155										
...	Reserved									
0x0157										
0x0158	USER14	7:0								
0x0159										
...	Reserved									
0x015B										
0x015C	USER15	7:0								
0x015D										
...	Reserved									
0x015F										
0x0160	USER16	7:0								
0x0161										
...	Reserved									
0x0163										
0x0164	USER17	7:0								
0x0165										
...	Reserved									
0x0167										
0x0168	USER18	7:0								
0x0169										
...	Reserved									
0x016B										
0x016C	USER19	7:0								
0x016D										
...	Reserved									
0x016F										
0x0170	USER20	7:0								
0x0171										
...	Reserved									
0x0173										
0x0174	USER21	7:0								
0x0175										
...	Reserved									
0x0177										
0x0178	USER22	7:0								
0x0179										
...	Reserved									
0x017B										
0x017C	USER23	7:0								

.....continued

Offset	Name	Bit Pos.	7	6	5	4	3	2	1	0
0x017D	Reserved									
...										
0x017F										
0x0180	USER24	7:0								CHANNEL[5:0]
0x0181	Reserved									
...										
0x0183										
0x0184	USER25	7:0								CHANNEL[5:0]
0x0185	Reserved									
...										
0x0187										
0x0188	USER26	7:0								CHANNEL[5:0]
0x0189	Reserved									
...										
0x018B										
0x018C	USER27	7:0								CHANNEL[5:0]
0x018D	Reserved									
...										
0x018F										
0x0190	USER28	7:0								CHANNEL[5:0]
0x0191	Reserved									
...										
0x0193										
0x0194	USER29	7:0								CHANNEL[5:0]
0x0195	Reserved									
...										
0x0197										
0x0198	USER30	7:0								CHANNEL[5:0]
0x0199	Reserved									
...										
0x019B										
0x019C	USER31	7:0								CHANNEL[5:0]
0x019D	Reserved									
...										
0x019F										
0x01A0	USER32	7:0								CHANNEL[5:0]
0x01A1	Reserved									
...										
0x01A3										
0x01A4	USER33	7:0								CHANNEL[5:0]
0x01A5	Reserved									
...										
0x01A7										
0x01A8	USER34	7:0								CHANNEL[5:0]
0x01A9	Reserved									
...										
0x01AB										
0x01AC	USER35	7:0								CHANNEL[5:0]
0x01AD	Reserved									
...										
0x01AF										
0x01B0	USER36	7:0								CHANNEL[5:0]
0x01B1	Reserved									
...										
0x01B3										
0x01B4	USER37	7:0								CHANNEL[5:0]
0x01B5	Reserved									
...										
0x01B7										
0x01B8	USER38	7:0								CHANNEL[5:0]

.....continued

Offset	Name	Bit Pos.	7	6	5	4	3	2	1	0
0x01B9	Reserved									
...										
0x01BB	Reserved									
0x01BC	USER39	7:0								
0x01BD	Reserved									
...										
0x01BF	Reserved									
0x01C0	USER40	7:0								
0x01C1	Reserved									
...										
0x01C3	Reserved									
0x01C4	USER41	7:0								
0x01C5	Reserved									
...										
0x01C7	Reserved									
0x01C8	USER42	7:0								
0x01C9	Reserved									
...										
0x01CB	Reserved									
0x01CC	USER43	7:0								
0x01CD	Reserved									
...										
0x01CF	Reserved									
0x01D0	USER44	7:0								
0x01D1	Reserved									
...										
0x01D3	Reserved									
0x01D4	USER45	7:0								
0x01D5	Reserved									
...										
0x01D7	Reserved									
0x01D8	USER46	7:0								
0x01D9	Reserved									
...										
0x01DB	Reserved									
0x01DC	USER47	7:0								
0x01DD	Reserved									
...										
0x01DF	Reserved									
0x01E0	USER48	7:0								
0x01E1	Reserved									
...										
0x01E3	Reserved									
0x01E4	USER49	7:0								
0x01E5	Reserved									
...										
0x01E7	Reserved									
0x01E8	USER50	7:0								
0x01E9	Reserved									
...										
0x01EB	Reserved									
0x01EC	USER51	7:0								
0x01ED	Reserved									
...										
0x01EF	Reserved									
0x01F0	USER52	7:0								
0x01F1	Reserved									
...										
0x01F3	Reserved									
0x01F4	USER53	7:0								

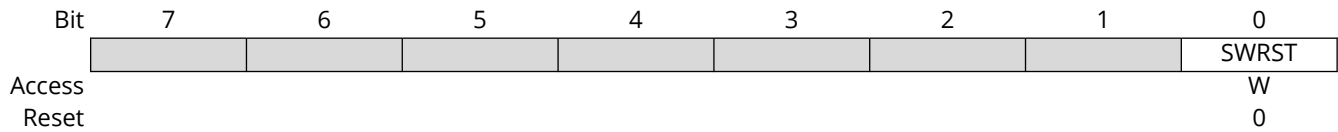
.....continued

Offset	Name	Bit Pos.	7	6	5	4	3	2	1	0
0x01F5	Reserved									
...										
0x01F7										
0x01F8	USER54	7:0								CHANNEL[5:0]
0x01F9	Reserved									
...										
0x01FB										
0x01FC	USER55	7:0								CHANNEL[5:0]
0x01FD	Reserved									
...										
0x01FF										
0x0200	USER56	7:0								CHANNEL[5:0]
0x0201	Reserved									
...										
0x0203										
0x0204	USER57	7:0								CHANNEL[5:0]
0x0205	Reserved									
...										
0x0207										
0x0208	USER58	7:0								CHANNEL[5:0]
0x0209	Reserved									
...										
0x020B										
0x020C	USER59	7:0								CHANNEL[5:0]
0x020D	Reserved									
...										
0x020F										
0x0210	USER60	7:0								CHANNEL[5:0]
0x0211	Reserved									
...										
0x0213										
0x0214	USER61	7:0								CHANNEL[5:0]
0x0215	Reserved									
...										
0x0217										
0x0218	USER62	7:0								CHANNEL[5:0]
0x0219	Reserved									
...										
0x021B										
0x021C	USER63	7:0								CHANNEL[5:0]
0x021D	Reserved									
...										
0x021F										
0x0220	USER64	7:0								CHANNEL[5:0]
0x0221	Reserved									
...										
0x0223										
0x0224	USER65	7:0								CHANNEL[5:0]
0x0225	Reserved									
...										
0x0227										
0x0228	USER66	7:0								CHANNEL[5:0]



### 30.6.1 Control A

**Name:** CTRLA  
**Offset:** 0x00  
**Reset:** 0x00  
**Property:** PAC Write-Protection



#### Bit 0 – SWRST Software Reset

Writing '0' to this bit has no effect.

Writing '1' to this bit resets all registers in the EVSYS to their initial state. It will always take precedence, meaning that all other writes in the same write-operation will be discarded.

**Note:** Before applying a Software Reset it is recommended to disable the event generators.

### 30.6.2 Software Event

**Name:** SWEVT  
**Offset:** 0x04  
**Reset:** 0x00000000  
**Property:** PAC Write-Protection

**Note:** Software Events are only supported in Asynchronous mode.

Bit	31	30	29	28	27	26	25	24
	CHANNEL31	CHANNEL30	CHANNEL29	CHANNEL28	CHANNEL27	CHANNEL26	CHANNEL25	CHANNEL24
Access	W	W	W	W	W	W	W	W
Reset	0	0	0	0	0	0	0	0

Bit	23	22	21	20	19	18	17	16
	CHANNEL23	CHANNEL22	CHANNEL21	CHANNEL20	CHANNEL19	CHANNEL18	CHANNEL17	CHANNEL16
Access	W	W	W	W	W	W	W	W
Reset	0	0	0	0	0	0	0	0

Bit	15	14	13	12	11	10	9	8
	CHANNEL15	CHANNEL14	CHANNEL13	CHANNEL12	CHANNEL11	CHANNEL10	CHANNEL9	CHANNEL8
Access	W	W	W	W	W	W	W	W
Reset	0	0	0	0	0	0	0	0

Bit	7	6	5	4	3	2	1	0
	CHANNEL7	CHANNEL6	CHANNEL5	CHANNEL4	CHANNEL3	CHANNEL2	CHANNEL1	CHANNEL0
Access	W	W	W	W	W	W	W	W
Reset	0	0	0	0	0	0	0	0

**Bits 0, 1, 2, 3, 4, 5, 6, 7, 8, 9, 10, 11, 12, 13, 14, 15, 16, 17, 18, 19, 20, 21, 22, 23, 24, 25, 26, 27, 28, 29, 30, 31 - CHANNELx** Channel x Software Selection [x=0..7]

Writing a '0' to this bit has no effect.

Writing a '1' to this bit will trigger a software event for channel x.

These bits always return '0' when read.

### 30.6.3 Priority Control

**Name:** PRICTRL  
**Offset:** 0x08  
**Reset:** 0x00  
**Property:** PAC Write-Protection

Bit	7	6	5	4	3	2	1	0
	RREN				PRI[3:0]			
Access	RW				RW	RW	RW	RW
Reset	0				0	0	0	0

#### Bit 7 – RREN Round-Robin Scheduling Enable

For details on scheduling schemes, refer to [Interrupt Status and Interrupts Arbitration](#)

Value	Description
0	Static scheduling scheme for channels with level priority
1	Round-robin scheduling scheme for channels with level priority

#### Bits 3:0 – PRI[3:0] Channel Priority Number

When round-robin arbitration is enabled (PRICTRL.RREN=1) for priority level, this register holds the channel number of the last EVSYS channel being granted access as the active channel with priority level. The value of this bit group is updated each time the INTPEND or any of CHINTFLAG registers are written.

When static arbitration is enabled (PRICTRL.RREN=0) for priority level, and the value of this bit group is nonzero, it will not affect the static priority scheme.

This bit group is not reset when round-robin scheduling gets disabled (PRICTRL.RREN written to zero).

### 30.6.4 Channel Pending Interrupt

**Name:** INTPEND  
**Offset:** 0x10  
**Reset:** 0x4000

An interrupt that handles several channels should consult the INTPEND register to find out which channel number has priority (ignoring/filtering each channel that has its own interrupt line). An interrupt dedicated to only one channel must not use the INTPEND register.

Bit	15	14	13	12	11	10	9	8
	BUSY	READY					EVD	OVR
Access	R	R					RW	RW
Reset	0	1					0	0
Bit	7	6	5	4	3	2	1	0
					ID[3:0]			
Access					RW	RW	RW	RW
Reset					0	0	0	0

#### Bit 15 – BUSY Busy

This bit is read '1' when the event on a channel selected by Channel ID field (ID) has not been handled by all the event users connected to this channel.

#### Bit 14 – READY Ready

This bit is read '1' when all event users connected to the channel selected by Channel ID field (ID) are ready to handle incoming events on this channel.

#### Bit 9 – EVD Channel Event Detected

This flag is set on the next CLK\_EVSYS\_APB cycle when an event is being propagated through the channel, and an interrupt request will be generated if CHINTENCLR/SET.EVD is '1'.

When the event channel path is asynchronous, the EVD bit will not be set.

Writing a '0' to this bit has no effect.

Writing a '1' to this bit will clear it. It will also clear the corresponding flag in the Channel n

Interrupt Flag Status and Clear register (CHINTFLAGn) of this peripheral, where n is determined by the Channel ID bit field (ID) in this register.

#### Bit 8 – OVR Channel Overrun

This flag is set on the next CLK\_EVSYS cycle after an overrun channel condition occurs, and an interrupt request will be generated if CHINTENCLR/SET.OVRx is '1'.

There are two possible overrun channel conditions:

- One or more of the event users on channel selected by Channel ID field (ID) are not ready when a new event occurs
- An event happens when the previous event on channel selected by Channel ID field (ID) has not yet been handled by all event users

When the event channel path is asynchronous, the OVR interrupt flag will not be set.

Writing a '0' to this bit has no effect.

Writing a '1' to this bit will clear it. It will also clear the corresponding flag in the Channel n

Interrupt Flag Status and Clear register (CHINTFLAGn) of this peripheral, where n is determined by the Channel ID bit field (ID) in this register.

#### Bits 3:0 – ID[3:0] Channel ID

These bits store the channel number of the highest priority.

When the bits are written, indirect access to the corresponding Channel Interrupt Flag register is enabled.

### 30.6.5 Interrupt Status

**Name:** INTSTATUS  
**Offset:** 0x14  
**Reset:** 0x00000000

Bit	31	30	29	28	27	26	25	24
Access								
Reset								
Bit	23	22	21	20	19	18	17	16
Access								
Reset								
Bit	15	14	13	12	11	10	9	8
Access					CHINT11	CHINT10	CHINT9	CHINT8
Reset					R	R	R	R
					0	0	0	0
Bit	7	6	5	4	3	2	1	0
Access	CHINT7	CHINT6	CHINT5	CHINT4	CHINT3	CHINT2	CHINT1	CHINT0
Reset	R	R	R	R	R	R	R	R
	0	0	0	0	0	0	0	0

#### Bits 0, 1, 2, 3, 4, 5, 6, 7, 8, 9, 10, 11 - CHINTx Channel x Pending Interrupt

This bit is set when Channel x has a pending interrupt.

This bit is cleared when the corresponding Channel x interrupts are disabled, or the source interrupt sources are cleared.

### 30.6.6 Busy Channels

**Name:** BUSYCH  
**Offset:** 0x18  
**Reset:** 0x00000000

Bit	31	30	29	28	27	26	25	24
Access								
Reset								
Bit	23	22	21	20	19	18	17	16
Access								
Reset								
Bit	15	14	13	12	11	10	9	8
Access					BUSYCH11	BUSYCH10	BUSYCH9	BUSYCH8
Reset					R	R	R	R
					0	0	0	0
Bit	7	6	5	4	3	2	1	0
Access	BUSYCH7	BUSYCH6	BUSYCH5	BUSYCH4	BUSYCH3	BUSYCH2	BUSYCH1	BUSYCH0
Reset	R	R	R	R	R	R	R	R
	0	0	0	0	0	0	0	0

#### Bits 0, 1, 2, 3, 4, 5, 6, 7, 8, 9, 10, 11 - BUSYCHx Busy Channel x

This bit is set if an event occurs on channel x has not been handled by all event users connected to channel x.

This bit is cleared when channel x is idle.

When the event channel x path is asynchronous, this bit is always read '0'.

### 30.6.7 Ready Users

**Name:** READYUSR  
**Offset:** 0x1C  
**Reset:** 111111111111

Bit	31	30	29	28	27	26	25	24
Access								
Reset								

Bit	23	22	21	20	19	18	17	16
Access								
Reset								

Bit	15	14	13	12	11	10	9	8
Access					R	R	R	R
Reset					1	1	1	1

Bit	7	6	5	4	3	2	1	0
Access	R	R	R	R	R	R	R	R
Reset	1	1	1	1	1	1	1	1

**Bits 0, 1, 2, 3, 4, 5, 6, 7, 8, 9, 10, 11 - READYUSRn** Ready User for Channel n

This bit is set when all event users connected to channel n are ready to handle incoming events on channel n.

This bit is cleared when at least one of the event users connected to the channel is not ready.

When the event channel n path is asynchronous, this bit is always read zero.



### 30.6.8 Channel n Control

**Name:** CHANNELn  
**Offset:** 0x20 + n\*0x08 [n=0..31]  
**Reset:** 0x00008000 for CHANNEL0-11, and 0x00000000 for CHANNEL12-31  
**Property:** PAC Write-Protection

This register allows the user to configure channel n. To write to this register, do a single, 32-bit write of all the configuration data.

Bit	31	30	29	28	27	26	25	24
Access								
Reset								
Bit	23	22	21	20	19	18	17	16
Access								
Reset								
Bit	15	14	13	12	11	10	9	8
Access	RW	RW			RW	RW	RW	RW
Reset	1	0			0	0	0	0
Bit	7	6	5	4	3	2	1	0
Access		RW	RW	RW	RW	RW	RW	RW
Reset		0	0	0	0	0	0	0

#### Bit 15 – ONDEMAND Generic Clock On Demand

This bit is used to determine whether the generic clock is requested.  
 This bit has no effect for channels when asynchronous path is selected or for channels with asynchronous support only.  
 This bit is always read zero for channels with asynchronous support only.

Value	Description
0	Generic clock for a channel is always on, if the channel is configured and generic clock source is enabled.
1	Generic clock is requested on demand while an event is handled

#### Bit 14 – RUNSTDBY Run in Standby

This bit is used to define the behavior during standby sleep mode, for a resynchronized channel.  
 This bit has no effect for channels when asynchronous path is selected or for channels with asynchronous support only.  
 This bit is always read zero for channels with asynchronous support only.

**Note:** In Synchronous mode, it is mandatory to enable the Generic Clock On Demand feature (CHANNEL.ONDEMAND=1).

Value	Description
0	The channel is disabled in standby sleep mode.
1	The channel is not stopped in standby sleep mode and depends on the CHANNEL.ONDEMAND bit.

#### Bits 11:10 – EDGSEL[1:0] Edge Detection Selection

These bits set the type of edge detection to be used on the channel.  
 These bits must be written to zero when using the asynchronous path.

Value	Name	Description
0x0	NO_EVT_OUTPUT	No event output when using the resynchronized path
0x1	RISING_EDGE	Event detection only on the rising edge of the signal from the event generator
0x2	FALLING_EDGE	Event detection only on the falling edge of the signal from the event generator
0x3	BOTH_EDGES	Event detection on rising and falling edges of the signal from the event generator

### Bits 9:8 – PATH[1:0] Path Selection

These bits are used to choose which path will be used by the selected channel.

**Note:** The path choice can be limited by the channel source, see the table in [30.6.13. USERm](#).



**Important:** Only EVSYS channel 0 to 11 can be configured as synchronous or resynchronized.

Value	Name	Description
0x0	SYNCHRONOUS	Synchronous path
0x1	RESYNCHRONIZED	Resynchronized path
0x2	ASYNCHRONOUS	Asynchronous path
Other	-	Reserved

### Bits 6:0 – EVGEN[6:0] Event Generator Selection

These bits are used to choose the event generator to connect to the selected channel.

Value	Name	Description
0x00	NONE	No event generator selected
0x01 - 0x02	OSCCTRL_XOSC_FAILx	XOSC fail detection x=0..1
0x03	OSC32KCTRL_XOSC32K_FAIL	XOSC32K fail detection
0x04 - 0x0B	RTC_PERx	RTC period x=0..7
0x0C - 0x0F	RTC_CMP	RTC comparison x=0..3
0x10	RTC_TAMPER	RTC tamper detection
0x11	RTC_OVF	RTC overflow
0x12 - 0x21	EIC_EXTINT	EIC external interrupt x=0..15
0x22 - 0x25	DMAC_CH	DMA channel x=0..3
0x26	PAC_ACCERR	PAC Acc. error
0x27	Reserved	-
0x28	Reserved	-
0x29	TCC0_OVF	TCC0 Overflow
0x2A	TCC0_TRG	TCC0 Trigger Event
0x2B	TCC0_CNT	TCC0 Counter
0x2C - 0x31	TCC0_MCx	TCC0 Match/Compare x=0..5
0x32	TCC1_OVF	TCC1 Overflow
0x33	TCC1_TRG	TCC1 Trigger Event
0x34	TCC1_CNT	TCC1 Counter
0x35 - 0x38	TCC1_MCx	TCC1 Match/Compare x=0..3
0x39	TCC2_OVF	TCC2 Overflow
0x3A	TCC2_TRG	TCC2 Trigger Event
0x3B	TCC2_CNT	TCC2 Counter
0x3C - 0x3E	TCC2_MCx	TCC2 Match/Compare x=0..2
0x3F	TCC3_OVF	TCC3 Overflow
0x40	TCC3_TRG	TCC3 Trigger Event
0x41	TCC3_CNT	TCC3 Counter
0x42 - 0x43	TCC3_MCx	TCC3 Match/Compare x=0..1
0x44	TCC4_OVF	TCC4 Overflow
0x45	TCC4_TRG	TCC4 Trigger Event
0x46	TCC4_CNT	TCC4 Counter

.....continued

Value	Name	Description
0x47 - 0x48	TCC4_MCx	TCC4 Match/Compare x=0..1
0x49	TC0_OVF	TC0 Overflow
0x4A - 0x4B	TC0_MCx	TC0 Match/Compare x=0..1
0x4C	TC1_OVF	TC1 Overflow
0x4D - 0x4E	TC1_MCx	TC1 Match/Compare x=0..1
0x4F	TC2_OVF	TC2 Overflow
0x50 - 0x51	TC2_MCx	TC2 Match/Compare x=0..1
0x52	TC3_OVF	TC3 Overflow
0x53 - 0x54	TC3_MCx	TC3 Match/Compare x=0..1
0x55	TC4_OVF	TC4 Overflow
0x56 - 0x57	TC4_MCx	TC4 Match/Compare x=0..1
0x58	TC5_OVF	TC5 Overflow
0x59 - 0x5A	TC5_MCx	TC5 Match/Compare x=0..1
0x5B	TC6_OVF	TC6 Overflow
0x5C - 0x5D	TC6_MCx	TC6 Match/Compare x=0..1
0x5E	TC7_OVF	TC7 Overflow
0x5F - 0x60	TC7_MCx	TC7 Match/Compare x=0..1
0x61	PDEC_OVF	PDEC Overflow
0x62	PDEC_ERR	PDEC Error
0x63	PDEC_DIR	PDEC Direction
0x64	PDEC_VLC	PDEC VLC
0x65 - 0x66	PDEC_MCx	PDEC MCx x=0..1
0x67	ADC0_RESRDY	ADC0 RESRDY
0x68	ADC0_WINMON	ADC0 Window Monitor
0x69	ADC1_RESRDY	ADC1 RESRDY
0x6A	ADC1_WINMON	ADC1 Window Monitor
0x6B - 0x6C	AC_COMPx	AC Comparator, x=0..1
0x6D	AC_WIN	AC0 Window
0x6E - 0x6F	DAC_EMPTYx	DAC empty, x=0..1
0x70 - 0x71	DAC_RESRDYx	DAC RSRDY, x=0..1
0x72	GMAC_TSU_CMP	GMAC Timestamp CMP
0x73	TRNG_READY	TRNG ready
0x74 - 0x77	CCL_LUTOUT	CCL LUTOUT
0x78 - 0x7F	Reserved	Reserved

### 30.6.9 Channel n Interrupt Enable Clear

**Name:** CHINTENCLR  
**Offset:** 0x24 + n\*0x08 [n=0..11]  
**Reset:** 0x00  
**Property:** PAC Write-Protection

Bit	7	6	5	4	3	2	1	0
							EVD	OVR
Access							RW	RW
Reset							0	0

#### Bit 1 – EVD Channel Event Detected Interrupt Disable

Writing a '0' to this bit has no effect.

Writing a '1' to this bit will clear the Event Detected Channel Interrupt Enable bit, which disables the Event Detected Channel interrupt.

Value	Description
0	The Event Detected Channel interrupt is disabled.
1	The Event Detected Channel interrupt is enabled.

#### Bit 0 – OVR Channel Overrun Interrupt Disable

Writing a '0' to this bit has no effect.

Writing a '1' to this bit will clear the Overrun Channel Interrupt Enable bit, which disables the Overrun Channel interrupt.

Value	Description
0	The Overrun Channel interrupt is disabled.
1	The Overrun Channel interrupt is enabled.

### 30.6.10 Channel n Interrupt Enable Set

**Name:** CHINTENSET  
**Offset:** 0x25 + n\*0x08 [n=0..11]  
**Reset:** 0x00  
**Property:** PAC Write-Protection

Bit	7	6	5	4	3	2	1	0
							EVD	OVR
Access							RW	RW
Reset							0	0

#### Bit 1 – EVD Channel Event Detected Interrupt Enable

Writing a '0' to this bit has no effect.

Writing a '1' to this bit will set the Event Detected Channel Interrupt Enable bit, which enables the Event Detected Channel interrupt.

Value	Description
0	The Event Detected Channel interrupt is disabled.
1	The Event Detected Channel interrupt is enabled.

#### Bit 0 – OVR Channel Overrun Interrupt Enable

Writing a '0' to this bit has no effect.

Writing a '1' to this bit will set the Overrun Channel Interrupt Enable bit, which enables the Overrun Channel interrupt.

Value	Description
0	The Overrun Channel interrupt is disabled.
1	The Overrun Channel interrupt is enabled.

### 30.6.11 Channel n Interrupt Flag Status and Clear

**Name:** CHINTFLAG  
**Offset:** 0x26 + n\*0x08 [n=0..11]  
**Reset:** 0x00

Bit	7	6	5	4	3	2	1	0
							EVD	OVR
Access							RW	RW
Reset							0	0

#### Bit 1 – EVD Channel Event Detected

This flag is set on the next CLK\_EVSYS\_APB cycle when an event is being propagated through the channel, and an interrupt request will be generated if CHINTENCLR/SET.EVD is '1'.

When the event channel path is asynchronous, the EVD interrupt flag will not be set.

Writing a '0' to this bit has no effect.

Writing a '1' to this bit will clear the Event Detected Channel interrupt flag.

#### Bit 0 – OVR Channel Overrun

This flag is set on the next CLK\_EVSYS cycle after an overrun channel condition occurs, and an interrupt request will be generated if CHINTENCLR/SET.OVRx is '1'.

There are two possible overrun channel conditions:

- One or more of the event users on the channel are not ready when a new event occurs.
- An event happens when the previous event on channel has not yet been handled by all event users.

When the event channel path is asynchronous, the OVR interrupt flag will not be set.

Writing a '0' to this bit has no effect.

Writing a '1' to this bit will clear the Overrun Channel interrupt flag.

### 30.6.12 Channel n Status

**Name:** CHSTATUSn  
**Offset:** 0x27 + n\*0x08 [n=0..11]  
**Reset:** 0x01

Bit	7	6	5	4	3	2	1	0
							BUSYCH	RDYUSR
Access							R	R
Reset							0	0

#### Bit 1 - BUSYCH Busy Channel

This bit is cleared when channel is idle.

This bit is set if an event on channel has not been handled by all event users connected to channel.

When the event channel path is asynchronous, this bit is always read '0'.

#### Bit 0 - RDYUSR Ready User

This bit is cleared when at least one of the event users connected to the channel is not ready.

This bit is set when all event users connected to channel are ready to handle incoming events on the channel.

When the event channel path is asynchronous, this bit is always read zero.

### 30.6.13 Event User m

**Name:** USERm  
**Offset:** 0x0120 + m\*0x04 [m=0..66]  
**Reset:** 0x0  
**Property:** PAC Write-Protection

Bit	7	6	5	4	3	2	1	0
	CHANNEL[5:0]							
Access			R/W	R/W	R/W	R/W	R/W	R/W
Reset			0	0	0	0	0	0

#### Bits 5:0 – CHANNEL[5:0] Channel Event Selection

These bits select channel n to connect to the event user m.

**Note:** A value x of this bit field selects channel n = x-1.

**Table 30-2.** User Multiplexer Number m

USERm	User Multiplexer	Description	Path Type <sup>(1)</sup>
m = 0	RTC_TAMPER	RTC Tamper	A
m = 1..4	PORT_EV0..3	PORT Event 0..3	A
m = 5..12	DMAC_CH0..7	Channel 0..7	S, R
m = 13	-	Reserved	-
m = 14	CM4_TRACE_START	CM4 trace start	S, R
m = 15	CM4_TRACE_STOP	CM4 trace stop	S, R
m = 16	CM4_TRACE_TRIG	CM4 trace trigger	S, R
m = 17..18	TCC0_EV0..1	TCC0 EVx	A, S, R
m = 19..24	TCC0_MC0..5	TCC0 MCx	A, S, R
m = 25..26	TCC1_EV0..1	TCC1 EVx	A, S, R
m = 27..30	TCC1_MC0..3	TCC1 MCx	A, S, R
m = 31..32	TCC2_EV0..1	TCC2 EVx	A, S, R
m = 33..35	TCC2_MC0..2	TCC2 MCx	A, S, R
m = 36..37	TCC3_EV0..1	TCC3 EVx	A, S, R
m = 38..39	TCC3_MC0..1	TCC3 MCx	A, S, R
m = 40..41	TCC4_EV0..1	TCC4 EVx	A, S, R
m = 42..43	TCC4_MC0..1	TCC4 MCx	A, S, R
m = 44..51	TC0..7 EVU	TC0..7 EVU	A, S, R
m = 52..54	PDEC_EVU 0..2	PDEC EVU x	A, S, R
m = 55	ADC0_START	ADC0 start conversion	A, S, R
m = 56	ADC0_SYNC	Flush ADC0	A, S, R
m = 57	ADC1_START	ADC1 start conversion	A, S, R
m = 58	ADC1_SYNC	Flush ADC1	A, S, R
m = 59..60	AC_SOC 0..1	AC SOC x	A
m = 61..62	DAC_START0..1	DAC0..1 start conversion	A
m = 63..66	CCL_LUTIN 0..3	CCL input	A
others	Reserved	-	-

1) A = Asynchronous path, S = Synchronous path, R = Resynchronized path

Value	Description
0x00	No channel selected
0x01	Channel 0 selected
0x02	Channel 1 selected
0x03	Channel 2 selected
0x04	Channel 3 selected
0x05	Channel 4 selected



Value	Description
0x06	Channel 5 selected
0x07	Channel 6 selected
0x08	Channel 7 selected
0x09	Channel 8 selected
0x0A	Channel 9 selected
0x0B	Channel 10 selected
0x0C	Channel 11 selected
0x0D	Channel 12 selected
0x0E	Channel 13 selected
0x0F	Channel 14 selected
0x10	Channel 15 selected
0x11	Channel 16 selected
0x12	Channel 17 selected
0x13	Channel 18 selected
0x14	Channel 19 selected
0x15	Channel 20 selected
0x16	Channel 21 selected
0x17	Channel 22 selected
0x18	Channel 23 selected
0x19	Channel 24 selected
0x1A	Channel 25 selected
0x1B	Channel 26 selected
0x1C	Channel 27 selected
0x1D	Channel 28 selected
0x1E	Channel 29 selected
0x1F	Channel 30 selected
0x20	Channel 31 selected
other	Reserved

## 31. Serial Communication Interface (SERCOM)

### 31.1 Overview

There are up to eight instances of the Serial Communication interface (SERCOM) peripheral.

A SERCOM can be configured to support a number of modes: I<sup>2</sup>C, SPI, and USART. When an instance of SERCOM is configured and enabled, all of the resources of that SERCOM instance will be dedicated to the selected mode.

The SERCOM serial engine consists of a transmitter and receiver, baud-rate generator and address matching functionality. It can use the internal generic clock or an external clock. Using an external clock allows the SERCOM to be operated in all Sleep modes.

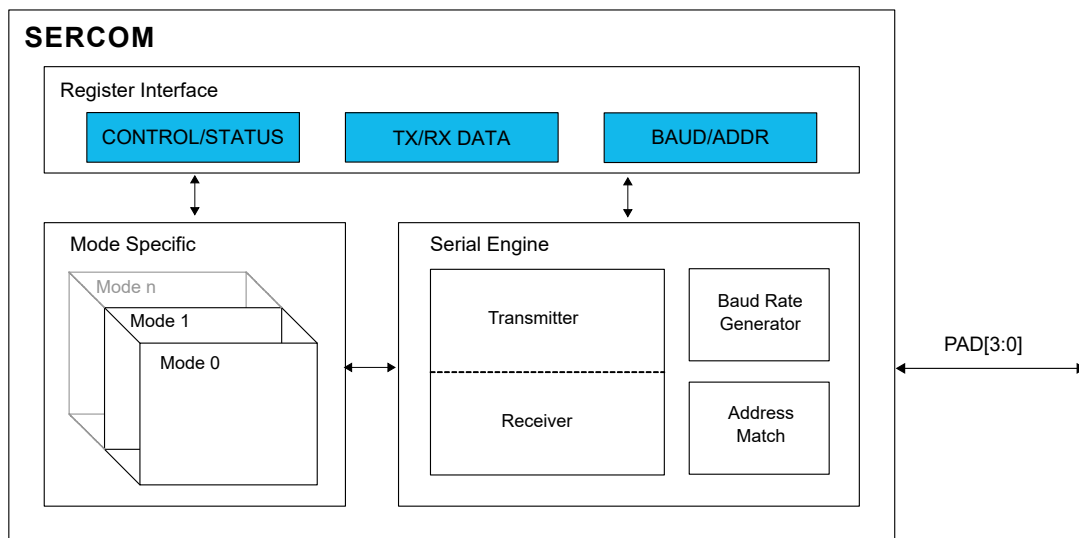
### 31.2 Features

The following are key features of the SERCOM:

- Interface for Configuring into one of the following (selected by CTRLA.MODE[2:0]):
  - Inter-Integrated Circuit (I<sup>2</sup>C) two-wire serial interface
  - System Management Bus (SMBus™) compatible
  - Serial Peripheral Interface (SPI)
  - Universal Synchronous/Asynchronous Receiver/Transmitter (USART)
- Single Transmit Buffer and Double Receive Buffer
- Baud-rate Generator
- Address Match/mask Logic
- Operational in all Sleep modes with an External Clock Source
- Can be used with DMA
- 32-bit Extension for Better System Bus Utilization

### 31.3 Block Diagram

Figure 31-1. SERCOM Block Diagram



### 31.4 Signal Description

See the respective SERCOM mode chapters for details.

- [SERCOM I<sup>2</sup>C](#)
- [SERCOM USART](#)
- [SERCOM SPI](#)



I/Os for SERCOM peripherals are grouped into IO sets. For these peripherals, it is mandatory to use I/Os that belong to the same I/O set. The timings are not guaranteed when I/Os from different I/O sets are mixed. Refer to the [Pinout and Packaging](#) chapter to get IOSET definitions.

## 31.5 Peripheral Dependencies

<b>Peripheral Name</b>	SERCOM0
<b>Base Address</b>	0x4000_3000 (Peripheral Bus A)
<b>NVIC IRQ Index:Source (1)</b>	46 : INT*[0]; 47 : INT*[1]; 48 : INT*[2]; 49 : INT*[3..7]
<b>MCLK APB Clock (2)</b>	CLK_SERCOM0_APB, Disabled, APBAMASK.SERCOM0
<b>GCLK Peripheral Channel Index:Clock Name (3)</b>	7 : GCLK_SERCOM0_CORE
<b>PAC Peripheral Peripheral Identifier (PAC.WRCTRL)</b>	12
<b>DMA Trigger Index:Source (DMAC.CHCTRLAK,k=0,1,...31)</b>	4 : RX, 5 : TX

<b>Peripheral Name</b>	SERCOM1
<b>Base Address</b>	0x4000_3400 (Peripheral Bus A)
<b>NVIC IRQ Index:Source (1)</b>	50 : INT*[0]; 51 : INT*[1]; 52 : INT*[2]; 53 : INT*[3..7]
<b>MCLK APB Clock (2)</b>	CLK_SERCOM1_APB, Disabled, APBAMASK.SERCOM1
<b>GCLK Peripheral Channel Index:Clock Name (3)</b>	8 : GCLK_SERCOM1_CORE
<b>PAC Peripheral Peripheral Identifier (PAC.WRCTRL)</b>	13
<b>DMA Trigger Index:Source (DMAC.CHCTRLAK,k=0,1,...31)</b>	6 : RX, 7 : TX

<b>Peripheral Name</b>	SERCOM2
<b>Base Address</b>	0x4101_2000 (Peripheral Bus B)
<b>NVIC IRQ Index:Source (1)</b>	54 : INT*[0]; 55 : INT*[1]; 56 : INT*[2]; 57 : INT*[3..7]
<b>MCLK APB Clock (2)</b>	CLK_SERCOM2_APB, Disabled, APBBMASK.SERCOM2
<b>GCLK Peripheral Channel Index:Clock Name (3)</b>	23 : GCLK_SERCOM2_CORE
<b>PAC Peripheral Peripheral Identifier (PAC.WRCTRL)</b>	41
<b>DMA Trigger Index:Source (DMAC.CHCTRLAK,k=0,1,...31)</b>	8 : RX, 9 : TX

<b>Peripheral Name</b>	SERCOM3
<b>Base Address</b>	0x4101_4000 (Peripheral Bus B)
<b>NVIC IRQ Index:Source (1)</b>	58 : INT*[0]; 59 : INT*[1]; 60 : INT*[2]; 61 : INT*[3..7]
<b>MCLK APB Clock (2)</b>	CLK_SERCOM3_APB, Disabled, APBBMASK.SERCOM3
<b>GCLK Peripheral Channel Index:Clock Name (3)</b>	24 : GCLK_SERCOM3_CORE
<b>PAC Peripheral Peripheral Identifier (PAC.WRCTRL)</b>	42
<b>DMA Trigger Index:Source (DMAC.CHCTRLAK,k=0,1,...31)</b>	10 : RX, 11 : TX

<b>Peripheral Name</b>	SERCOM4
<b>Base Address</b>	0x4300_0000 (Peripheral Bus D)
<b>NVIC IRQ Index:Source (1)</b>	62 : INT*[0]; 63 : INT*[1]; 64 : INT*[2]; 65 : INT*[3..7]
<b>MCLK APB Clock (2)</b>	CLK_SERCOM4_APB, Disabled, APBDMASK.SERCOM4
<b>GCLK Peripheral Channel Index:Clock Name (3)</b>	34 : GCLK_SERCOM4_CORE

<b>PAC Peripheral Peripheral Identifier (PAC.WRCTRL)</b>	96
<b>DMA Trigger Index:Source (DMAC.CHCTRLAk,k=0,1,...31)</b>	12 : RX, 13 : TX

<b>Peripheral Name</b>	SERCOM5
<b>Base Address</b>	0x4300_0400 (Peripheral Bus D)
<b>NVIC IRQ Index:Source (1)</b>	66 : INT*[0], 67 : INT*[1], 68 : INT*[2], 69 : INT*[3..7]
<b>MCLK APB Clock (2)</b>	CLK_SERCOM5_APB, Disabled, APBDMASK.SERCOM5
<b>GCLK Peripheral Channel Index:Clock Name (3)</b>	35 : GCLK_SERCOM5_CORE
<b>PAC Peripheral Peripheral Identifier (PAC.WRCTRL)</b>	97
<b>DMA Trigger Index:Source (DMAC.CHCTRLAk,k=0,1,...31)</b>	14 : RX, 15 : TX

<b>Peripheral Name</b>	SERCOM6
<b>Base Address</b>	0x4300_0800 (Peripheral Bus D)
<b>NVIC IRQ Index:Source (1)</b>	70 : INT*[0], 71 : INT*[1], 72 : INT*[2], 73 : INT*[3..7]
<b>MCLK APB Clock (2)</b>	CLK_SERCOM6_APB, Disabled, APBDMASK.SERCOM6
<b>GCLK Peripheral Channel Index:Clock Name (3)</b>	36 : GCLK_SERCOM6_CORE
<b>PAC Peripheral Peripheral Identifier (PAC.WRCTRL)</b>	98
<b>DMA Trigger Index:Source (DMAC.CHCTRLAk,k=0,1,...31)</b>	16 RX, 17 : TX

<b>Peripheral Name</b>	SERCOM7
<b>Base Address</b>	0x4300_0C00 (Peripheral Bus D)
<b>NVIC IRQ Index:Source (1)</b>	74 : INT*[0], 75 : INT*[1], 76 : INT*[2], 77 : INT*[3..7]
<b>MCLK APB Clock (2)</b>	CLK_SERCOM7_APB, Disabled, APBDMASK.SERCOM7
<b>GCLK Peripheral Channel Index:Clock Name (3)</b>	37 : GCLK_SERCOM7_CORE
<b>PAC Peripheral Peripheral Identifier (PAC.WRCTRL)</b>	99
<b>DMA Trigger Index:Source (DMAC.CHCTRLAk,k=0,1,...31)</b>	18 : RX, 19 : TX

#### Notes:

1. 'INT\*[n]' refers to the interrupt defined for bit n of the INTFLAG register.
2. Clock Name, Default State, Mask Field.
3. See GCLK.PCHCTRLm Register, where m = Index.

### 31.5.1 I/O Lines

Using the SERCOM I/O lines requires the I/O pins to be configured using port configuration ([PORT](#)).

The SERCOM has four internal pads, PAD[3:0], and the signals from I<sup>2</sup>C, SPI and USART are routed through these SERCOM pads through a multiplexer. The configuration of the multiplexer is available from the different SERCOM modes. Refer to the mode specific chapters for additional information.

- [SERCOM I<sup>2</sup>C](#)
- [SERCOM USART](#)
- [SERCOM SPI](#)

### 31.5.2 Power Management

The SERCOM can operate in any Sleep mode provided the selected clock source is running. SERCOM interrupts can be configured to wake the device from sleep modes.

### 31.5.3 Clocks

The SERCOM bus clock (CLK\_SERCOMx\_APB) can be enabled and disabled in the [Main Clock Controller](#). Refer to [Peripheral Clock Masking](#) for details and default status of this clock.

The SERCOM uses two generic clocks: GCLK\_SERCOMx\_CORE and GCLK\_SERCOMx\_SLOW. The core clock (GCLK\_SERCOMx\_CORE) is required to clock the SERCOM while working as a host. The slow clock (GCLK\_SERCOMx\_SLOW) is only required for certain functions. See specific mode chapters for details.

These clocks must be configured and enabled in the [Generic Clock Controller \(GCLK\)](#) before using the SERCOM.

The generic clocks are asynchronous to the user interface clock (CLK\_SERCOMx\_APB). Due to this asynchronicity, writing to certain registers will require synchronization between the clock domains. Refer to [31.6.7. Synchronization](#) for details.

### 31.5.4 Debug Operation

When the CPU is halted in Debug mode, this peripheral will continue normal operation. If the peripheral is configured to require periodical service by the CPU through interrupts or similar, improper operation or data loss may result during debugging. This peripheral can be forced to halt operation during debugging - refer to the Debug Control (DBGCTRL) register for details.

### 31.5.5 Register Access Protection

Registers with write-access can be write-protected optionally by the [Peripheral Access Controller \(PAC\)](#).

Optional write protection by the Peripheral Access Controller (PAC) is denoted by the "PAC Write Protection" property in each individual register description.

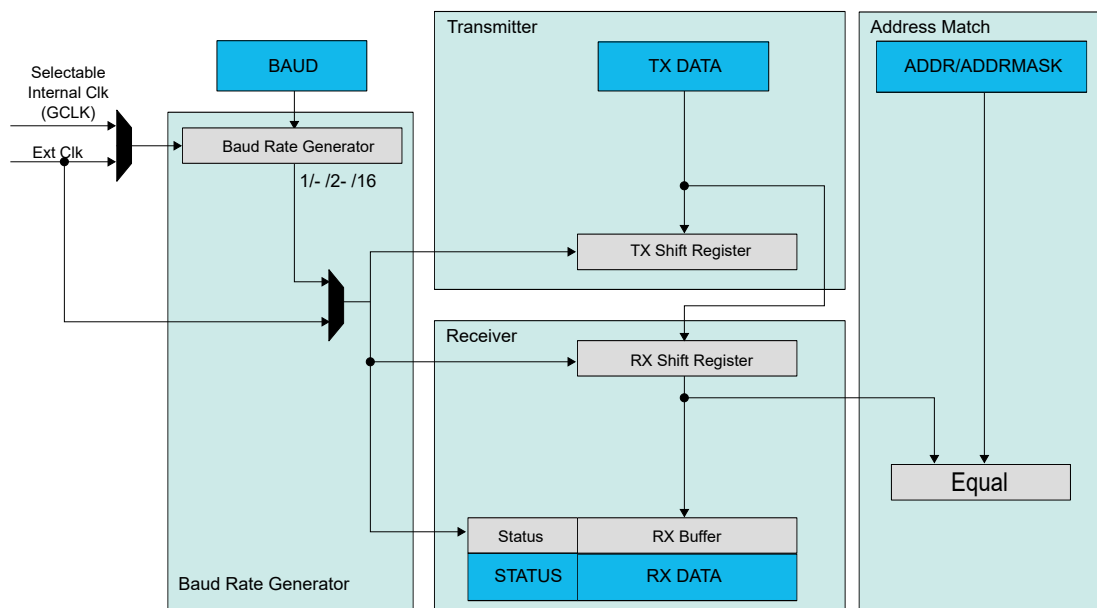
PAC write protection does not apply to accesses through an external debugger.

## 31.6 Functional Description

### 31.6.1 Principle of Operation

The basic structure of the SERCOM serial engine is shown in the following figure. Labels in capital letters are synchronous to the system clock and accessible by the CPU; labels in lowercase letters can be configured to run on the GCLK\_SERCOMx\_CORE clock or an external clock.

Figure 31-2. SERCOM Serial Engine



The transmitter consists of a single write buffer and a Shift register.

The receiver consists of a one-level (I<sup>2</sup>C), or two-level (USART, SPI) receive buffer and a Shift register.

The baud-rate generator is capable of running on the GCLK\_SERCOMx\_CORE clock or an external clock.

Address matching logic is included for SPI and I<sup>2</sup>C operation.

## 31.6.2 Basic Operation

### 31.6.2.1 Initialization

The SERCOM must be configured to the desired mode by writing the Operating Mode bits in the Control A register (CTRLA.MODE) as shown in the table below.

**Table 31-1.** SERCOM Modes

CTRLA.MODE	Description
0x0	USART with external clock
0x1	USART with internal clock
0x2	SPI in Client operation
0x3	SPI in Host operation
0x4	I <sup>2</sup> C Client operation
0x5	I <sup>2</sup> C Host operation
0x6-0x7	Reserved

For further initialization information, see the respective SERCOM mode chapters:

- [SERCOM I<sup>2</sup>C](#)
- [SERCOM USART](#)
- [SERCOM SPI](#)

### 31.6.2.2 Enabling, Disabling, and Resetting

This peripheral is enabled by writing '1' to the Enable bit in the Control A register (CTRLA.ENABLE), and disabled by writing '0' to it.

Writing '1' to the Software Reset bit in the Control A register (CTRLA.SWRST) will reset all registers of this peripheral to their initial states, except the DBGCTRL register, and the peripheral is disabled.

Refer to the CTRLA register description for details.

### 31.6.2.3 Clock Generation – Baud-Rate Generator

The baud-rate generator, as shown in the following figure, generates internal clocks for asynchronous and synchronous communication. The output frequency ( $f_{\text{BAUD}}$ ) is determined by the Baud register (BAUD) setting and the baud reference frequency ( $f_{\text{ref}}$ ). The baud reference clock is the serial engine clock, and it can be internal or external.

For asynchronous communication, the /16 (divide-by-16) output is used when transmitting, whereas the /1 (divide-by-1) output is used while receiving.

For synchronous communication, the /2 (divide-by-2) output is used.

This functionality is automatically configured, depending on the selected operating mode.

Figure 31-3. Baud Rate Generator

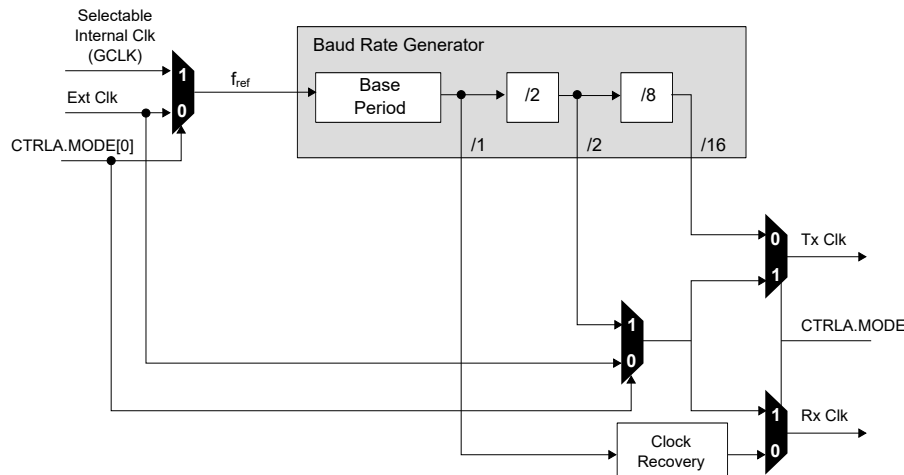


Table 31-2 contains equations for the baud rate (in bits per second) and the BAUD register value for each operating mode.

For asynchronous operation, there is one mode: *arithmetic mode*, the BAUD register value is 16 bits (0 to 65,535), *fractional mode*, the BAUD register value is 13 bits, while the fractional adjustment is 3 bits. In this mode the BAUD setting must be greater than or equal to 1.

For synchronous operation, the BAUD register value is 8 bits (0 to 255).

Table 31-2. Baud Rate Equations

Operating Mode	Condition	Baud Rate (Bits Per Second)	BAUD Register Value Calculation
Asynchronous Arithmetic	$f_{BAUD} \leq \frac{f_{ref}}{16}$	$f_{BAUD} = \frac{f_{ref}}{16} \left(1 - \frac{BAUD}{65536}\right)$	$BAUD = 65536 \cdot \left(1 - S \cdot \frac{f_{BAUD}}{f_{ref}}\right)$
Asynchronous Fractional	$f_{BAUD} \leq \frac{f_{ref}}{S}$	$f_{BAUD} = \frac{f_{ref}}{S \cdot \left(BAUD + \frac{FP}{8}\right)}$	$BAUD = \frac{f_{ref}}{S \cdot f_{BAUD}} - \frac{FP}{8}$
Synchronous	$f_{BAUD} \leq \frac{f_{ref}}{2}$	$f_{BAUD} = \frac{f_{ref}}{2 \cdot (BAUD + 1)}$	$BAUD = \frac{f_{ref}}{2 \cdot f_{BAUD}} - 1$

S - Number of samples per bit, which can be 16, 8, or 3.

The Asynchronous Fractional option is used for auto-baud detection.

The baud rate error is represented by the following formula:

$$\text{Error} = 1 - \left(\frac{\text{ExpectedBaudRate}}{\text{ActualBaudRate}}\right)$$

### 31.6.2.3.1 Asynchronous Arithmetic Mode BAUD Value Selection

The formula given for  $f_{BAUD}$  calculates the average frequency over 65536  $f_{ref}$  cycles. Although the BAUD register can be set to any value between 0 and 65536, the actual average frequency of  $f_{BAUD}$  over a single frame is more granular. The BAUD register values that will affect the average frequency over a single frame lead to an integer increase in the cycles per frame (CPF).

$$CPF = \frac{f_{ref}}{f_{BAUD}}(D + S)$$

Where,

- D represent the data bits per frame

- $S$  represent the sum of start and first stop bits, if present.

The following table shows the BAUD register value versus baud frequency  $f_{\text{BAUD}}$  at a serial engine frequency of 48 MHz. This assumes a  $D$  value of 8 bits and an  $S$  value of 2 bits (10 bits, including start and stop bits).

**Table 31-3.** BAUD Register Value vs. Baud Frequency

BAUD Register Value	Serial Engine CPF	$f_{\text{BAUD}}$ at 100 MHz Serial Engine Frequency ( $f_{\text{REF}}$ )
0 – 406	161	6.211 MHz
407 – 808	162	6.211 MHz
809 – 1205	163	6.173 MHz
...	...	...
65206	31775	31.47 kHz
65207	31872	31.38 kHz
65208	31969	31.28 kHz

### 31.6.3 Additional Features

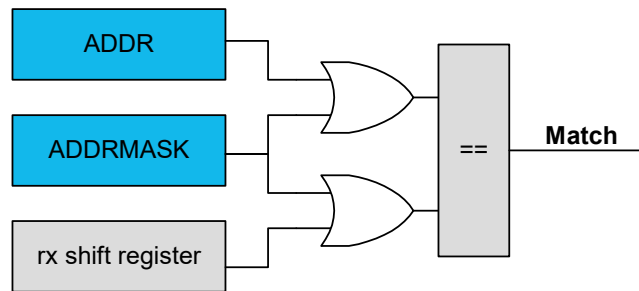
#### 31.6.3.1 Address Match and Mask

The SERCOM address match and mask feature is capable of matching either one address, two unique addresses, or a range of addresses with a mask, based on the mode selected. The match uses seven or eight bits, depending on the mode.

##### Address With Mask

An address written to the Address bits in the Address register (ADDR.ADDR), and a mask written to the Address Mask bits in the Address register (ADDR.ADDRMASK) will yield an address match. All bits that are masked are not included in the match. Note that writing the ADDR.ADDRMASK to 'all zeros' will match a single unique address, while writing ADDR.ADDRMASK to 'all ones' will result in all addresses being accepted.

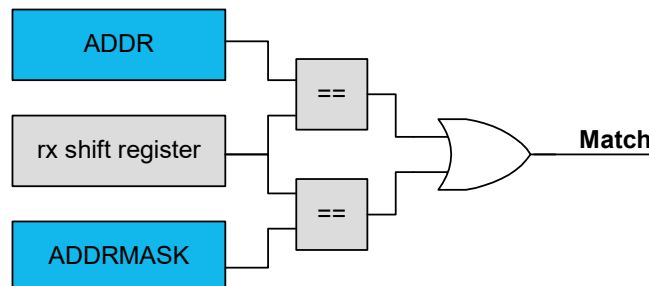
**Figure 31-4.** Address With Mask



##### Two Unique Addresses

The two addresses written to ADDR and ADDRMASK will cause a match.

**Figure 31-5.** Two Unique Addresses

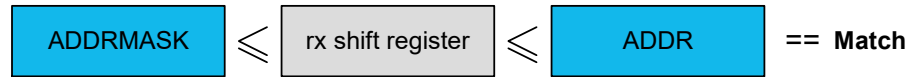




### Address Range

The range of addresses between and including ADDR.ADDR and ADDR.ADDRMASK will cause a match. ADDR.ADDR and ADDR.ADDRMASK can be set to any two addresses, with ADDR.ADDR acting as the upper limit and ADDR.ADDRMASK acting as the lower limit.

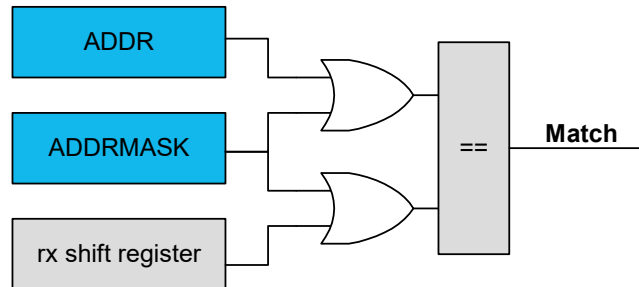
Figure 31-6. Address Range



#### 31.6.3.1.1 Address With Mask

An address written to the Address bits in the Address register (ADDR.ADDR), and a mask written to the Address Mask bits in the Address register (ADDR.ADDRMASK) will yield an address match. All bits that are masked are not included in the match. Note that writing the ADDR.ADDRMASK to 'all zeros' will match a single unique address, while writing ADDR.ADDRMASK to 'all ones' will result in all addresses being accepted.

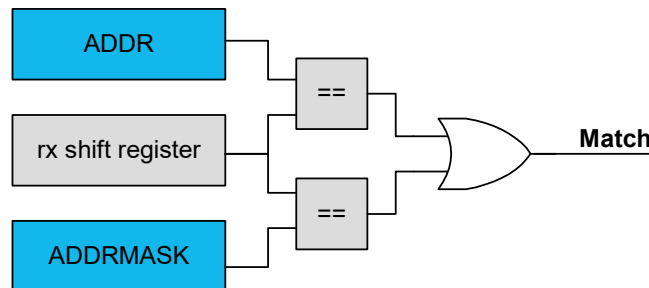
Figure 31-7. Address With Mask



#### 31.6.3.1.2 Two Unique Addresses

The two addresses written to ADDR and ADDRMASK will cause a match.

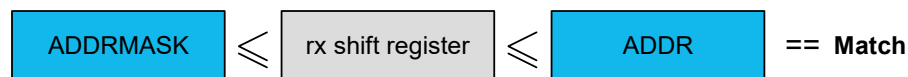
Figure 31-8. Two Unique Addresses



#### 31.6.3.1.3 Address Range

The range of addresses between and including ADDR.ADDR and ADDR.ADDRMASK will cause a match. ADDR.ADDR and ADDR.ADDRMASK can be set to any two addresses, with ADDR.ADDR acting as the upper limit and ADDR.ADDRMASK acting as the lower limit.

Figure 31-9. Address Range



### 31.6.4 DMA Operation

The available DMA interrupts and their depend on the operation mode of the SERCOM peripheral. Refer to the Functional Description sections of the respective SERCOM mode.

- [SERCOM I<sup>2</sup>C](#)
- [SERCOM USART](#)
- [SERCOM SPI](#)

### 31.6.5 Interrupts

Interrupt sources are mode specific. See the respective SERCOM mode chapters for details.

Each interrupt source has its own Interrupt flag.

The Interrupt flag in the Interrupt Flag Status and Clear register (INTFLAG) will be set when the Interrupt condition is met.

Each interrupt can be individually enabled by writing '1' to the corresponding bit in the Interrupt Enable Set register (INTENSET), and disabled by writing '1' to the corresponding bit in the Interrupt Enable Clear register (INTENCLR).

An interrupt request is generated when the Interrupt flag is set and the corresponding interrupt is enabled. The interrupt request remains active until either the Interrupt flag is cleared, the interrupt is disabled, or the SERCOM is reset. For details on clearing Interrupt flags, refer to the INTFLAG register description.

The value of INTFLAG indicates which Interrupt condition occurred. The user must read the INTFLAG register to determine which Interrupt condition is present.

**Note:** Interrupts must be globally enabled for interrupt requests to be generated.

### 31.6.6 Sleep Mode Operation

The peripheral can operate in any Sleep mode where the selected serial clock is running. This clock can be external or generated by the internal baud-rate generator.

The SERCOM interrupts can be used to wake-up the device from Sleep modes. Refer to the different SERCOM mode chapters for details.

- [SERCOM I<sup>2</sup>C](#)
- [SERCOM USART](#)
- [SERCOM SPI](#)

### 31.6.7 Synchronization

Due to asynchronicity between the main clock domain and the peripheral clock domains, some registers need to be synchronized when written or read.

Required write synchronization is denoted by the "Write-Synchronized" property in the register description.

Required read synchronization is denoted by the "Read-Synchronized" property in the register description.

## 32. SERCOM Synchronous and Asynchronous Receiver and Transmitter (SERCOM USART)

### 32.1 Overview

The Universal Synchronous and Asynchronous Receiver and Transmitter (USART) is one of the available modes in the [Serial Communication Interface \(SERCOM\)](#).

The USART uses the SERCOM transmitter and receiver, see [32.3. Block Diagram](#). Labels in uppercase letters are synchronous to CLK\_SERCOMx\_APB and accessible for CPU. Labels in lowercase letters can be programmed to run on the internal generic clock or an external clock.

The transmitter consists of a single write buffer, a Shift register, and control logic for different frame formats. The write buffer support data transmission without any delay between frames. The receiver consists of a two-level receive buffer and a Shift register. Status information of the received data is available for error checking. Data and clock recovery units ensure robust synchronization and noise filtering during asynchronous data reception.

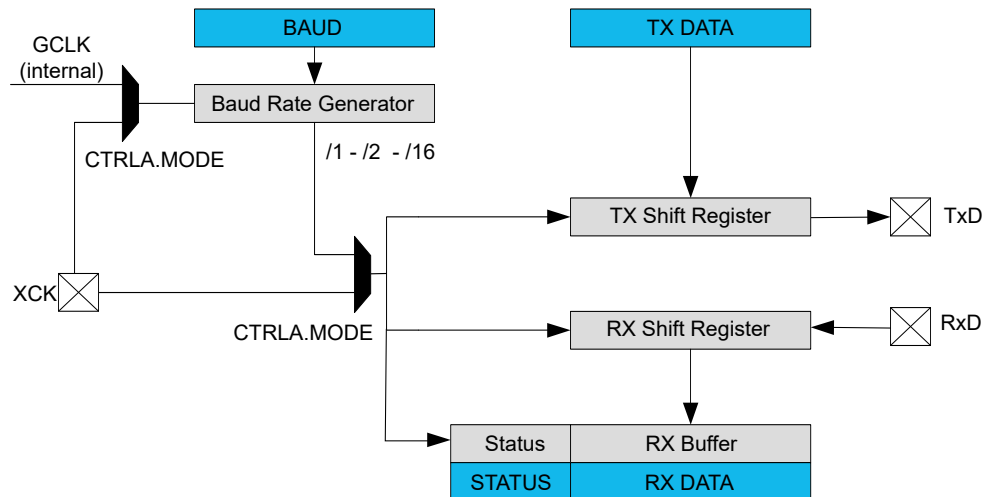
### 32.2 USART Features

The following are key features of the SERCOM USART:

- Full-duplex Operation
- Asynchronous (with Clock Reconstruction) or Synchronous Operation
- Internal or External Clock source for Asynchronous and Synchronous Operation
- Baud-rate Generator
- Supports Serial Frames with 5, 6, 7, 8 or 9 Data bits and 1 or 2 Stop bits
- Odd or Even Parity Generation and Parity Check
- Selectable LSB- or MSB-first Data Transfer
- Buffer Overflow and Frame Error Detection
- Noise Filtering, Including False Start bit Detection and Digital Low-pass Filter
- Collision Detection
- Can Operate in all Sleep modes
- Operation at Speeds up to Half the System Clock for Internally Generated Clocks
- Operation at Speeds up to the System Clock for Externally Generated Clocks
- RTS and CTS Flow Control
- IrDA Modulation and Demodulation up to 115.2 kbps
- LIN Host Support
- LIN Client Support
  - Auto-baud and break character detection
- ISO 7816 T = 0 or T = 1 protocols for Smart Card Interfacing
- RS485 Support
- Start-of-frame detection
- Two-Level Receive Buffer
- Can work with DMA
- 32-bit Extension for Better System Bus Utilization

## 32.3 Block Diagram

Figure 32-1. USART Block Diagram



## 32.4 Signal Description

Table 32-1. SERCOM USART Signals

Signal Name	Type	Description
PAD[3:0]	Digital I/O	General SERCOM pins



I/Os for SERCOM peripherals are grouped into I/O sets. For these peripherals, it is mandatory to use I/Os that belong to the same I/O set. The timings are not guaranteed when I/Os from different I/O sets are mixed. Refer to the [Pinout and Packaging](#) chapter to get IOSET definitions.

## 32.5 Peripheral Dependencies

Refer to Section 33.5 [Peripheral Dependencies](#) for more information.

### 32.5.1 I/O Lines

Using the USART's I/O lines requires the I/O pins to be configured using the [I/O Pin Controller \(PORT\)](#).

When the SERCOM is used in USART mode, the SERCOM controls the direction and value of the I/O pins according to the table below. If the receiver or transmitter is disabled, these pins can be used for other purposes.

Table 32-2. USART Pin Configuration

Pin	Pin Configuration
TxD	Output
RxD	Input
XCK	Output or input

The combined configuration of PORT and the Transmit Data Pinout and Receive Data Pinout bit fields in the Control A register (CTRLA.TXPO and CTRLA.RXPO, respectively) will define the physical position of the USART signals in the table above.

## 32.6 Functional Description

### 32.6.1 Principle of Operation

The USART uses the following lines for data transfer:

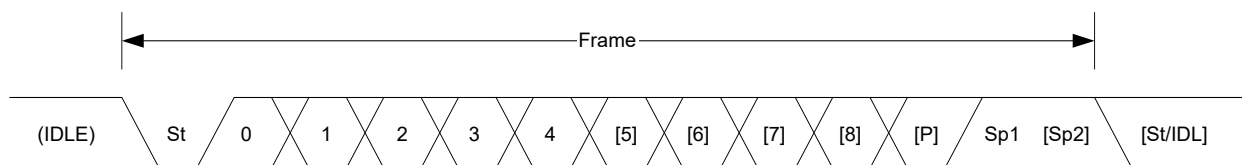
- RxD for receiving
- TxD for transmitting
- XCK for the transmission clock in synchronous operation

USART data transfer is frame based. A serial frame consists of:

- 1 start bit
- From 5 to 9 data bits (MSB or LSB first)
- No, even or odd parity bit
- 1 or 2 stop bits

A frame starts with the Start bit followed by one character of Data bits. If enabled, the parity bit is inserted after the Data bits and before the first Stop bit. After the Stop bits of a frame, either the next frame can follow immediately, or the communication line can return to the Idle (high) state. The figure below illustrates the possible frame formats. Values inside brackets ([x]) denote optional bits.

**Figure 32-2.** Frame Formats



St Start bit. Signal is always low.

n, [n] Data bits. 0 to [5..9]

[P] Parity bit. Either odd or even.

Sp, [Sp] Stop bit. Signal is always high.

IDLE No frame is transferred on the communication line. Signal is always high in this state.

### 32.6.2 Basic Operation

#### 32.6.2.1 Initialization

The following registers are enable-protected, meaning they can only be written when the USART is disabled (CTRL.ENABLE = 0):

- Control A register (CTRLA), except the Enable (ENABLE) and Software Reset (SWRST) bits.
- Control B register (CTRLB), except the Receiver Enable (RXEN) and Transmitter Enable (TXEN) bits.
- Baud register (BAUD).

When the USART is enabled or is being enabled (CTRLA.ENABLE = 1), any writing attempt to these registers will be discarded. If the peripheral is being disabled, writing to these registers will be executed after disabling is completed. Enable-protection is denoted by the "Enable-Protection" property in the register description.

Before the USART is enabled, it must be configured by these steps:

1. Select either external (0x0) or internal clock (0x1) by writing the Operating Mode value in the CTRLA register (CTRLA.MODE).

2. Select either Asynchronous (0) or Synchronous (1) Communication mode by writing the Communication Mode bit in the CTRLA register (CTRLA.CMODE).
3. Select pin for receive data by writing the Receive Data Pinout value in the CTRLA register (CTRLA.RXPO).
4. Select pads for the transmitter and external clock by writing the Transmit Data Pinout bit in the CTRLA register (CTRLA.TXPO).
5. Configure the Character Size field in the CTRLB register (CTRLB.CHSIZE) for character size.
6. Set the Data Order bit in the CTRLA register (CTRLA.DORD) to determine MSB- or LSB-first data transmission.
7. To use parity mode:
  - a. Enable Parity mode by writing 0x1 to the Frame Format field in the CTRLA register (CTRLA.FORM).
  - b. Configure the Parity Mode bit in the CTRLB register (CTRLB.PMODE) for even or odd parity.
8. Configure the number of stop bits in the Stop Bit Mode bit in the CTRLB register (CTRLB.SBMODE).
9. When using an internal clock, write the Baud register (BAUD) to generate the desired baud rate.
10. Enable the transmitter and receiver by writing '1' to the Receiver Enable and Transmitter Enable bits in the CTRLB register (CTRLB.RXEN and CTRLB.TXEN).

### 32.6.2.2 Enabling, Disabling, and Resetting

This peripheral is enabled by writing '1' to the Enable bit in the Control A register (CTRLA.ENABLE), and disabled by writing '0' to it.

Writing '1' to the Software Reset bit in the Control A register (CTRLA.SWRST) will reset all registers of this peripheral to their initial states, and the peripheral is disabled.

**Note:** Software Reset (CTRLA.SWRST=1) is not functional when the SERCOM is not enabled (CTRLA.ENABLE=0).

Refer to the [CTRLA](#) register description for details.

### 32.6.2.3 Clock Generation and Selection

For both Synchronous and Asynchronous modes, the clock used for shifting and sampling data can be generated internally by the SERCOM baud-rate generator or supplied externally through the XCK line.

The Synchronous mode is selected by writing a '1' to the Communication Mode bit in the Control A register (CTRLA.CMODE), the Asynchronous mode is selected by writing '0' to CTRLA.CMODE.

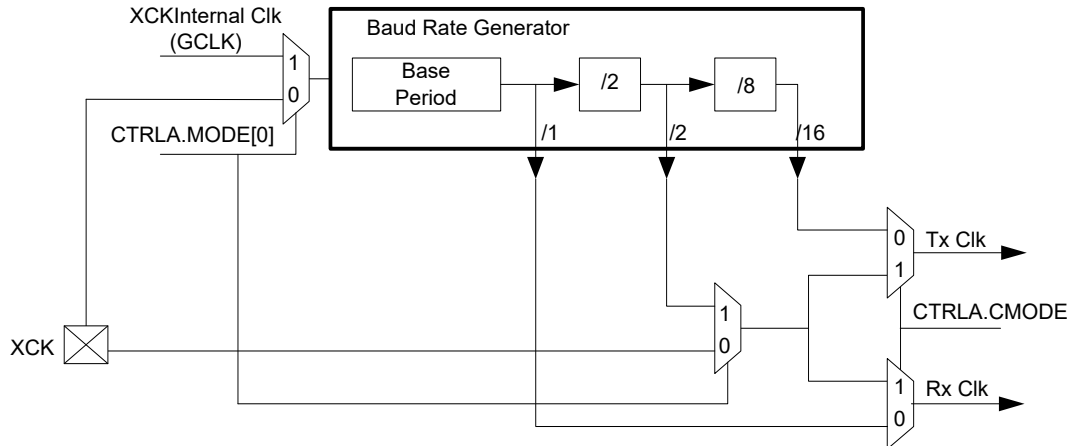
The internal clock source is selected by writing '1' to the Operation Mode bit field in the Control A register (CTRLA.MODE), the external clock source is selected by writing '0' to CTRLA.MODE.

The SERCOM baud-rate generator is configured as in the following figure.

In Asynchronous mode (CTRLA.CMODE = 0), the 16-bit Baud register value is used.

In Synchronous mode (CTRLA.CMODE = 1), the eight LSBs of the Baud register are used. Refer to [Clock Generation – Baud-Rate Generator](#) for details on configuring the baud rate.

Figure 32-3. Clock Generation



### 32.6.2.3.1 Synchronous Clock Operation

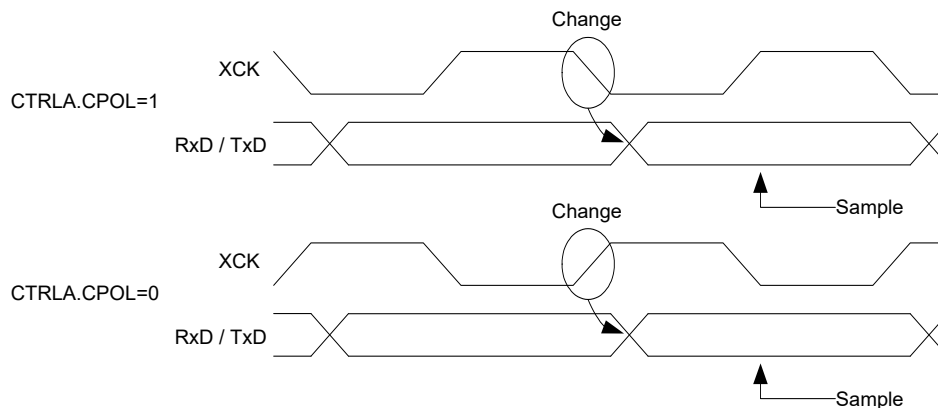
In Synchronous mode, the CTRLA.MODE bit field determines whether the transmission clock line (XCK) serves either as input or output. The dependency between clock edges, data sampling, and data change is the same for internal and external clocks. Data input on the RxD pin is sampled at the opposite XCK clock edge when data is driven on the TxD pin.

The Clock Polarity bit in the Control A register (CTRLA.CPOL) selects which XCK clock edge is used for RxD sampling, and which is used for TxD change:

When CTRLA.CPOL is '0', the data will be changed on the rising edge of XCK, and sampled on the falling edge of XCK.

When CTRLA.CPOL is '1', the data will be changed on the falling edge of XCK, and sampled on the rising edge of XCK.

Figure 32-4. Synchronous Mode XCK Timing



When the clock is provided through XCK (CTRLA.MODE=0x0), the Shift registers operate directly on the XCK clock. This means that XCK is not synchronized with the system clock and, therefore, can operate at frequencies up to the system frequency.

### 32.6.2.4 Data Register

The USART Transmit Data register (TxDATA) and USART Receive Data register (RxDATA) share the same I/O address, referred to as the Data register (DATA). Writing the DATA register will update the TxDATA register. Reading the DATA register will return the contents of the RxDATA register.

### 32.6.2.5 Data Transmission

Data transmission is initiated by writing the data to be sent into the DATA register. Then, the data in TxDATA will be moved to the Shift register when the Shift register is empty and ready to send a new frame. After the Shift register is loaded with data, the data frame will be transmitted.

When the entire data frame including the Stop bit has been transmitted (both the Tx buffer and the Shift register are empty) and no new data was written to the DATA register, the Transmit Complete Interrupt flag in the Interrupt Flag Status and Clear register (INTFLAG.TXC) will be set, and the optional interrupt can be generated.

The DATA Register Empty Flag in the Interrupt Flag Status and Clear register (INTFLAG.DRE) indicates that the register is empty and ready for new data. The DATA register must only be written to when INTFLAG.DRE is set.

#### Disabling the Transmitter

The transmitter is disabled by writing '0' to the Transmitter Enable bit in the CTRLB register (CTRLB.TXEN).

Disabling the transmitter will complete only after any ongoing and pending transmissions are completed, i.e., there is no data in the Transmit Shift register and TxDATA to transmit.

### 32.6.2.6 Data Reception

The receiver accepts data when a valid Start bit is detected. Each bit following the Start bit will be sampled according to the baud rate or XCK clock, and shifted into the receive Shift register until the first Stop bit of a frame is received. The second Stop bit will be ignored by the receiver.

When the first Stop bit is received and a complete serial frame is present in the Receive Shift register, the contents of the Shift register will be moved into the two-level receive buffer. Then, the Receive Complete Interrupt flag in the Interrupt Flag Status and Clear register (INTFLAG.RXC) will be set, and the optional interrupt can be generated.

The received data can be read from the DATA register when the Receive Complete Interrupt flag is set.

#### Disabling the Receiver

Writing '0' to the Receiver Enable bit in the CTRLB register (CTRLB.RXEN) will disable the receiver, flush the two-level receive buffer, and data from ongoing receptions will be lost.

#### Error Bits

The USART receiver has three error bits in the Status (STATUS) register: Frame Error (FERR), Buffer Overflow (BUFOVF), and Parity Error (PERR). Once an error happens, the corresponding error bit will be set until it is cleared by writing '1' to it. These bits are also cleared automatically when the receiver is disabled.

There are two methods for buffer overflow notification, selected by the Immediate Buffer Overflow Notification bit in the Control A register (CTRLA.IBON):

When CTRLA.IBON = 1, STATUS.BUFOVF is raised immediately upon buffer overflow. Software can then empty the receive FIFO by reading RxDATA, until the receiver complete interrupt flag (INTFLAG.RXC) is cleared.

When CTRLA.IBON = 0, the buffer overflow condition is attending data through the receive FIFO. After the received data is read, STATUS.BUFOVF will be set along with INTFLAG.RXC.

#### Asynchronous Data Reception

The USART includes a clock recovery and data recovery unit for handling asynchronous data reception.

The clock recovery logic can synchronize the incoming asynchronous serial frames at the RxD pin to the internally generated baud-rate clock.



The data recovery logic samples and applies a low-pass filter to each incoming bit, thereby improving the noise immunity of the receiver.

### Asynchronous Operational Range

The operational range of the asynchronous reception depends on the accuracy of the internal baud-rate clock, the rate of the incoming frames, and the frame size (in number of bits). In addition, the operational range of the receiver is depending on the difference between the received bit rate and the internally generated baud rate. If the baud rate of an external transmitter is too high or too low compared to the internally generated baud rate, the receiver will not be able to synchronize the frames to the start bit.

There are two possible sources for a mismatch in baud rate: First, the reference clock will always have some minor instability. Second, the baud-rate generator cannot always do an exact division of the reference clock frequency to get the baud rate desired. In this case, the BAUD register value should be set to give the lowest possible error. Refer to [Clock Generation – Baud-Rate Generator](#) for details.

Recommended maximum receiver baud-rate errors for various character sizes are shown in the table below.

**Table 32-3.** Asynchronous Receiver Error for 16-fold Oversampling

D (Data bits+Parity)	R <sub>SLOW</sub> [%]	R <sub>FAST</sub> [%]	Max. total error [%]	Recommended max. Rx error [%]
5	91.42	107.69	+5.88/-7.69	±2.5
6	94.92	106.67	+5.08/-6.67	±2.0
7	95.52	105.88	+4.48/-5.88	±2.0
8	96.00	105.26	+4.00/-5.26	±2.0
9	96.39	104.76	+3.61/-4.76	±1.5
10	96.70	104.35	+3.30/-4.35	±1.5

The following equations calculate the ratio of the incoming data rate and internal receiver baud rate:

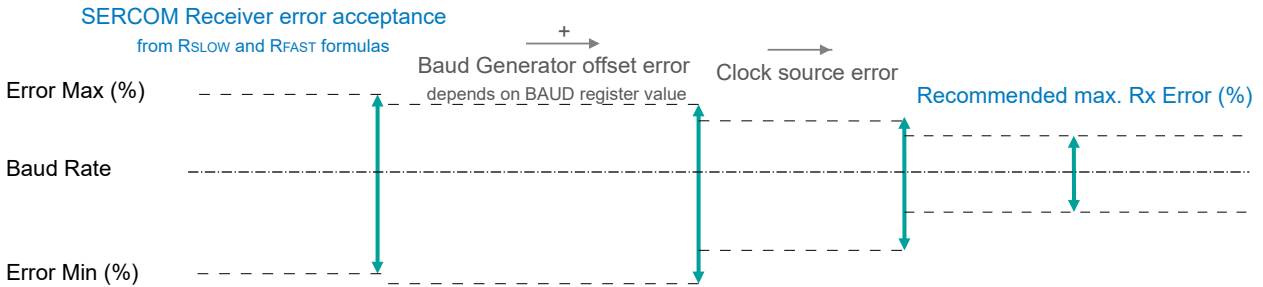
$$R_{\text{SLOW}} = \frac{16(D + 1)}{16(D + 1) + 6} \quad , \quad R_{\text{FAST}} = \frac{16(D + 2)}{16(D + 1) + 8}$$

Where,

- $R_{\text{SLOW}}$  is the ratio of the slowest incoming data rate that can be accepted in relation to the receiver baud rate.
- $R_{\text{FAST}}$  is the ratio of the fastest incoming data rate that can be accepted in relation to the receiver baud rate.
- $D$  is the sum of character size and parity size ( $D = 5$  to 10 bits).

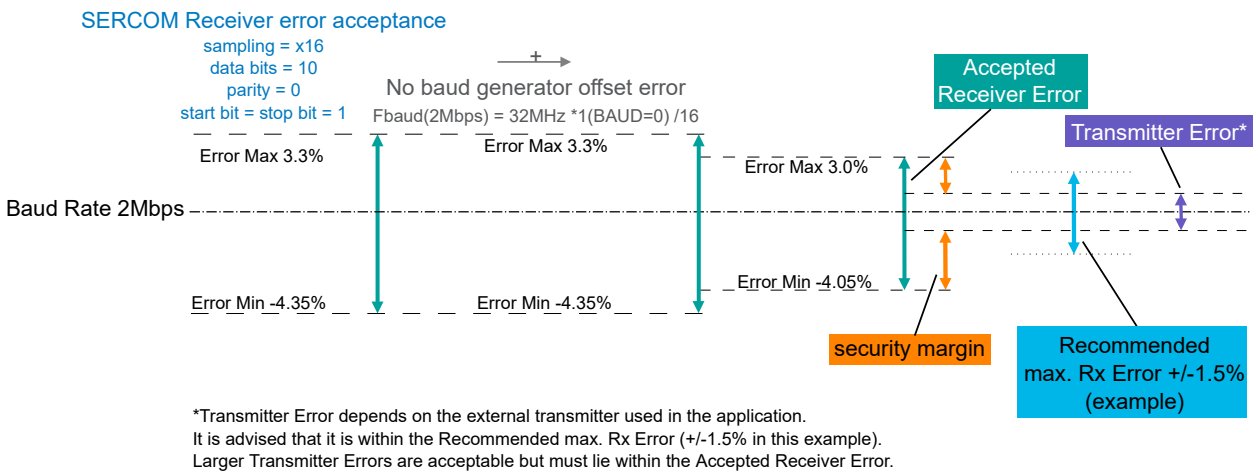
The recommended maximum Rx Error assumes that the receiver and transmitter equally divide the maximum total error. Its connection to the SERCOM Receiver error acceptance is depicted in this figure:

**Figure 32-5. USART Rx Error Calculation**



The recommendation values in the table above accommodate errors of the clock source and the baud generator. The following figure gives an example for a baud rate of 3 Mbps:

**Figure 32-6. USART Rx Error Calculation Example**



### 32.6.2.6.1 Disabling the Receiver

Writing '0' to the Receiver Enable bit in the CTRLB register (CTRLB.RXEN) will disable the receiver, flush the two-level receive buffer, and data from ongoing receptions will be lost.

### 32.6.2.6.2 Error Bits

The USART receiver has three error bits in the Status (STATUS) register: Frame Error (FERR), Buffer Overflow (BUFOVF), and Parity Error (PERR). Once an error happens, the corresponding error bit will be set until it is cleared by writing '1' to it. These bits are also cleared automatically when the receiver is disabled.

There are two methods for buffer overflow notification, selected by the Immediate Buffer Overflow Notification bit in the Control A register (CTRLA.IBON):

When CTRLA.IBON = 1, STATUS.BUFOVF is raised immediately upon buffer overflow. Software can then empty the receive FIFO by reading RxDATA, until the Receiver Complete Interrupt flag (INTFLAG.RXC) is cleared.

When CTRLA.IBON = 0, the Buffer Overflow condition travels with data through the receive FIFO, which will then set the INTFLAG.ERROR bit. After the received data is read, STATUS.BUFOVF (and INTFLAG.ERROR) will be set along with INTFLAG.RXC.

### 32.6.2.6.3 Asynchronous Data Reception

The USART includes a clock recovery and data recovery unit for handling asynchronous data reception.

The clock recovery logic can synchronize the incoming asynchronous serial frames at the RxD pin to the internally generated baud-rate clock.

The data recovery logic samples and applies a low-pass filter to each incoming bit, thereby improving the noise immunity of the receiver.

#### 32.6.2.6.4 Asynchronous Operational Range

The operational range of the asynchronous reception depends on the accuracy of the internal baud-rate clock, the rate of the incoming frames, and the frame size (in number of bits). In addition, the operational range of the receiver is depending on the difference between the received bit rate and the internally generated baud rate. If the baud rate of an external transmitter is too high or too low compared to the internally generated baud rate, the receiver will not be able to synchronize the frames to the start bit.

There are two possible sources for a mismatch in baud rate: First, the reference clock will always have some minor instability. Second, the baud-rate generator cannot always do an exact division of the reference clock frequency to get the baud rate desired. In this case, the BAUD register value should be set to give the lowest possible error. Refer to [Clock Generation – Baud-Rate Generator](#) for details.

Recommended maximum receiver baud-rate errors for various character sizes are shown in the table below.

**Table 32-4.** Asynchronous Receiver Error for 16-fold Oversampling

D (Data bits+Parity)	R <sub>SLOW</sub> [%]	R <sub>FAST</sub> [%]	Max. total error [%]	Recommended max. Rx error [%]
5	94.12	107.69	+5.88/-7.69	±2.5
6	94.92	106.67	+5.08/-6.67	±2.0
7	95.52	105.88	+4.48/-5.88	±2.0
8	96.00	105.26	+4.00/-5.26	±2.0
9	96.39	104.76	+3.61/-4.76	±1.5
10	96.70	104.35	+3.30/-4.35	±1.5

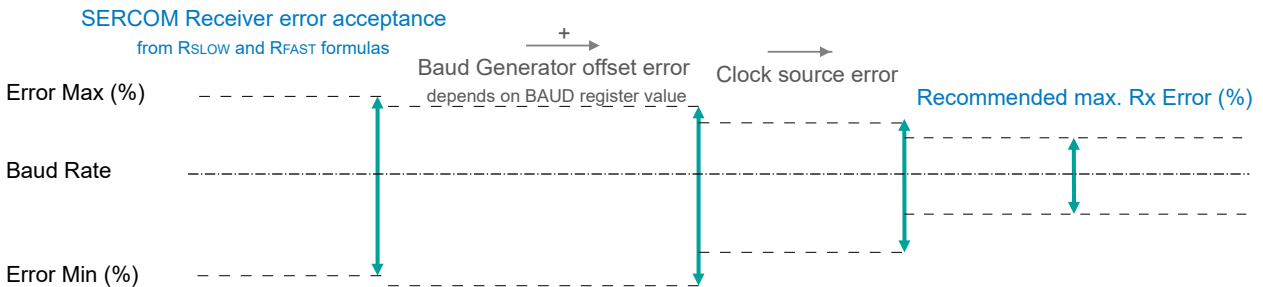
The following equations calculate the ratio of the incoming data rate and internal receiver baud rate:

$$R_{\text{SLOW}} = \frac{(D + 1)S}{S - 1 + D \cdot S + S_F} \quad , \quad R_{\text{FAST}} = \frac{(D + 2)S}{(D + 1)S + S_M}$$

- $R_{\text{SLOW}}$  is the ratio of the slowest incoming data rate that can be accepted in relation to the receiver baud rate
- $R_{\text{FAST}}$  is the ratio of the fastest incoming data rate that can be accepted in relation to the receiver baud rate
- $D$  is the sum of character size and parity size ( $D = 5$  to  $10$  bits)
- $S$  is the number of samples per bit ( $S = 16, 8$  or  $3$ )
- $S_F$  is the first sample number used for majority voting ( $S_F = 7, 3,$  or  $2$ ) when CTRLA.SAMPA=0.
- $S_M$  is the middle sample number used for majority voting ( $S_M = 8, 4,$  or  $2$ ) when CTRLA.SAMPA=0.

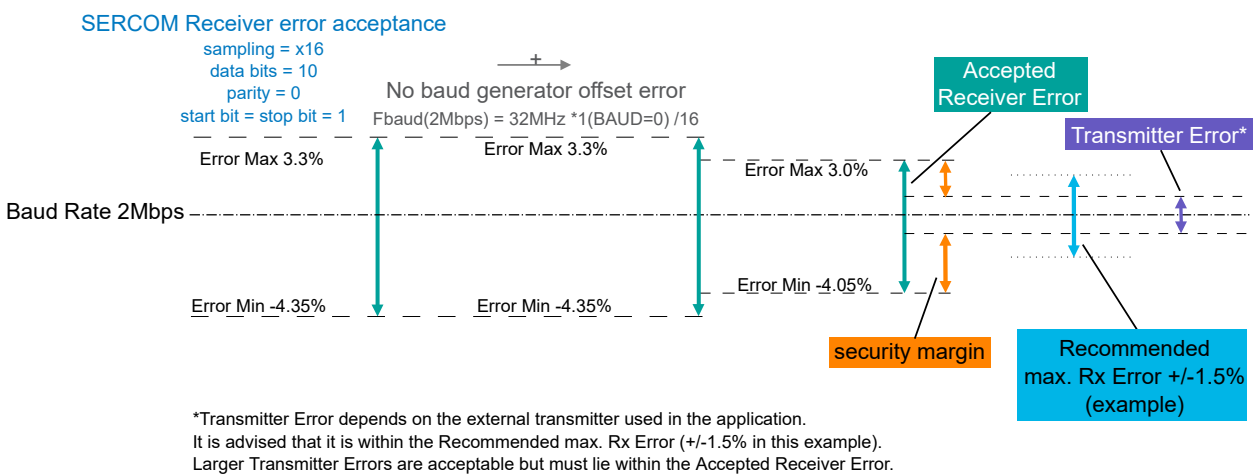
The recommended maximum Rx Error assumes that the receiver and transmitter equally divide the maximum total error. Its connection to the SERCOM Receiver error acceptance is depicted in this figure:

Figure 32-7. USART Rx Error Calculation



The recommendation values in the table above accommodate errors of the clock source and the baud generator. The following figure gives an example for a baud rate of 3Mbps:

Figure 32-8. USART Rx Error Calculation Example



### 32.6.3 Additional Features

#### 32.6.3.1 Parity

Even or odd parity can be selected for error checking by writing 0x1 to the Frame Format bit field in the Control A register (CTRLA.FORM).

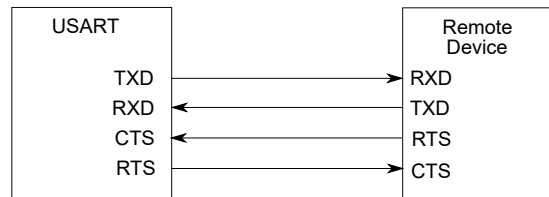
If *even parity* is selected (CTRLB.PMODE = 0), the Parity bit of an outgoing frame is '1' if the data contains an odd number of bits that are '1', making the total number of '1' even.

If *odd parity* is selected (CTRLB.PMODE = 1), the Parity bit of an outgoing frame is '1' if the data contains an even number of bits that are '0', making the total number of '1' odd.

When parity checking is enabled, the parity checker calculates the parity of the data bits in incoming frames and compares the result with the Parity bit of the corresponding frame. If a parity error is detected, the Parity Error bit in the Status register (STATUS.PERR) is set.

#### 32.6.3.2 Hardware Handshaking

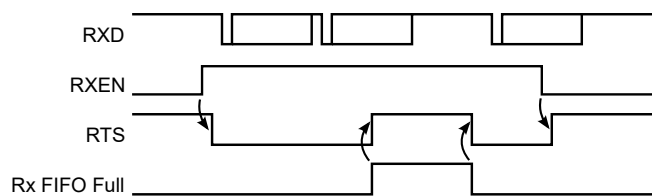
The USART features an out-of-band hardware handshaking flow control mechanism, implemented by connecting the RTS and CTS pins with the remote device, as shown in the figure below.

**Figure 32-9.** Connection with a Remote Device for Hardware Handshaking

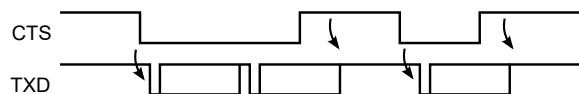
Hardware handshaking is only available in the following configuration:

- USART with internal clock (CTRLA.MODE = 1),
- Asynchronous mode (CTRLA.CMODE = 0)
- Flow control pinout (CTRLA.TXPO = 2).

When the receiver is disabled or the receive FIFO is full, the receiver will drive the RTS pin high. This notifies the remote device to stop transfer after the ongoing transmission. Enabling and disabling the receiver by writing to CTRLB.RXEN will set/clear the RTS pin after a synchronization delay. When the receive FIFO goes full, RTS will be set immediately and the frame being received will be stored in the Shift register until the receive FIFO is no longer full.

**Figure 32-10.** Receiver Behavior when Operating with Hardware Handshaking

The current CTS Status is in the STATUS register (STATUS.CTS). Character transmission will start only if STATUS.CTS = 0. When CTS is set, the transmitter will complete the ongoing transmission and stop transmitting.

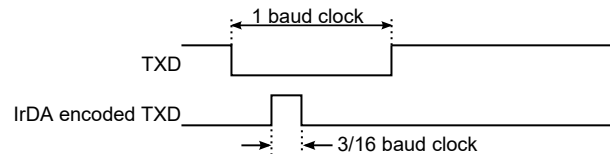
**Figure 32-11.** Transmitter Behavior when Operating with Hardware Handshaking

### 32.6.3.3 IrDA Modulation and Demodulation

Transmission and reception can be encoded IrDA compliant up to 115.2 kb/s. IrDA modulation and demodulation work in the following configuration:

- IrDA encoding enabled (CTRLB.ENC = 1)
- Asynchronous mode (CTRLA.CMODE = 0)
- and 16x sample rate (CTRLA.SAMPR[0] = 0).

During transmission, each low bit is transmitted as a high pulse. The pulse width is 3/16 of the baud rate period, as illustrated in the figure below.

**Figure 32-12.** IrDA Transmit Encoding

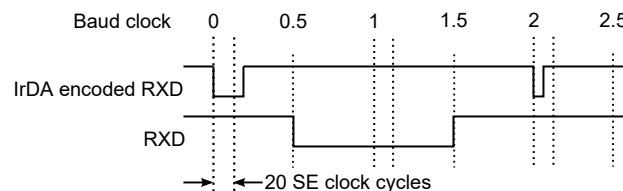
The reception decoder has two main functions.

The first is to synchronize the incoming data to the IrDA baud rate counter. Synchronization is performed at the start of each zero pulse.

The second main function is to decode incoming Rx data. If a pulse width meets the minimum length set by configuration (RXPL.RXPL), it is accepted. When the baud rate counter reaches its middle value (1/2 bit length), it is transferred to the receiver.

**Note:** The polarity of the transmitter and receiver are opposite: During transmission, a '0' bit is transmitted as a '1' pulse. During reception, an accepted '0' pulse is received as a '0' bit.

**Example:** The figure below illustrates reception where RXPL.RXPL is set to 19. This indicates that the pulse width should be at least 20 SE clock cycles. When using BAUD = 0xE666 or 160 SE cycles per bit, this corresponds to 2/16 baud clock as minimum pulse width required. In this case the first bit is accepted as a '0', the second bit is a '1', and the third bit is also a '1'. A low pulse is rejected since it does not meet the minimum requirement of 2/16 baud clock.

**Figure 32-13.** IrDA Receive Decoding

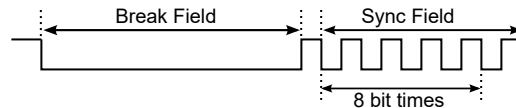
### 32.6.3.4 Break Character Detection and Auto-Baud/LIN Client

The break character detection and auto-baud are available in this configuration:

- Auto-baud frame format (CTRLA.FORM = 0x04 or 0x05)
- Asynchronous mode (CTRLA.CMODE = 0)
- 16x sample rate using fractional baud rate generation (CTRLA.SAMPR = 1).

The USART uses a break detection threshold of greater than 11 nominal bit times at the configured baud rate. At any time, if more than 11 consecutive dominant bits are detected on the bus, the USART detects a Break Field. When a break field has been detected, the Receive Break Interrupt Flag (INTFLAG.RXBRK) is set and the USART expects the sync field character to be 0x55. This field is used to update the actual baud rate in order to stay synchronized. If the received sync character is not 0x55, then the Inconsistent Sync Field error flag (STATUS.ISF) is set along with the Error Interrupt Flag (INTFLAG.ERROR), and the baud rate is unchanged.

The auto-baud follows the LIN format. All LIN Frames start with a Break Field followed by a Sync Field.

**Figure 32-14.** LIN Break and Sync Fields

After a Break field is detected and the Start bit of the Sync field is detected, a counter is started. The counter is then incremented for the next 8 bit times of the Sync field. At the end of these 8 bit times, the counter is stopped. At this moment, the 13 Most Significant bits of the counter (value divided by 8) give the new clock divider (BAUD.BAUD), and the 3 Least Significant bits of this value (the remainder) give the new Fractional Part (BAUD.FP).

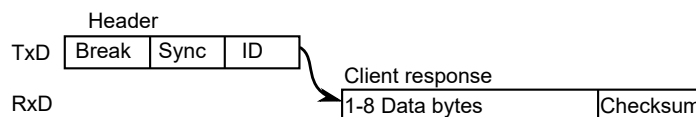
When the Sync field has been received, the clock divider (BAUD.BAUD) and the Fractional Part (BAUD.FP) are updated after a synchronization delay. After the Break and Sync fields are received, multiple characters of data can be received.

### 32.6.3.5 LIN Host

The LIN Host is available with the following configuration:

- LIN Host format (CTRLA.FORM = 0x02)
- Asynchronous mode (CTRLA.CMODE = 0)
- 16x sample rate using fractional baud rate generation (CTRLA.SAMPR = 1)

LIN frames start with a header transmitted by the Host. The header consists of the break, sync, and identifier fields. After the Host transmits the header, the addressed Client will respond with 1-8 bytes of data plus checksum.

**Figure 32-15.** LIN Frame Format

Using the LIN command field (CTRLB.LINCMD), the complete header can be automatically transmitted, or software can control transmission of the various header components.

When CTRLB.LINCMD = 0x1, software controls transmission of the LIN header. In this case, software uses the following sequence.

1. The CTRLB.LINCMD is written to 0x1.
2. The DATA register written to 0x00. This triggers transmission of the break field by hardware. Writing the DATA register with any other value will also result in the transmission of the break field by hardware.
3. The DATA register written to 0x55. The 0x55 value (sync) is transmitted.
4. The DATA register written to the identifier. The identifier is transmitted.

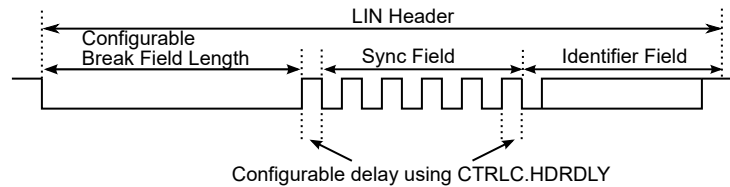
**Note:** It is recommended to use The DATA Register Empty flag in the Interrupt Flag Status and Clear register (INTFLAG.DRE) to ensure no extra delay is added during the transmission of the data.

When CTRLB.LINCMD = 0x2, hardware controls transmission of the LIN header. In this case, software uses the following sequence:

1. The CTRLB.LINCMD is written to 0x2.
2. The DATA register written to the identifier. This triggers transmission of the complete header by hardware. First the break field is transmitted. Next, the sync field is transmitted, and finally the identifier is transmitted.

In LIN Host mode, the length of the break field is programmable using the break length field (CTRLC.BRKLEN). When the LIN header command is used (CTRLB.LINCMD = 0x2), the delay between the Break and Sync fields, in addition to the delay between the Sync and ID fields are configurable using the header delay field (CTRLC.HDRDLY). When manual transmission is used (CTRLB.LINCMD = 0x1), software controls the delay between the Break and Sync.

**Figure 32-16.** LIN Header Generation



After header transmission is complete, the Client responds with 1-8 data bytes plus checksum.

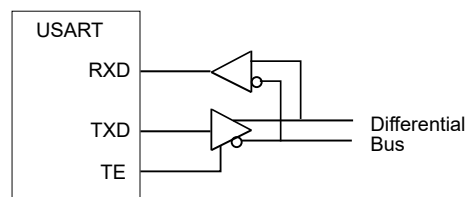
### 32.6.3.6 RS485

RS485 is available with the following configuration:

- USART frame format (CTRLA.FORM = 0x00 or 0x01)
- RS485 pinout (CTRLA.TXPO = 0x3).

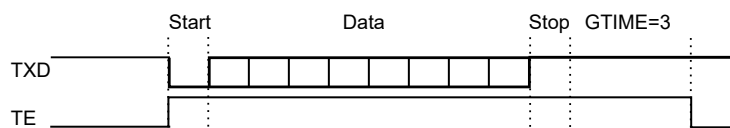
The RS485 feature enables control of an external line driver as shown in the figure below. While operating in RS485 mode, the transmit enable pin (TE) is driven high when the transmitter is active.

**Figure 32-17.** RS485 Bus Connection



The TE pin will remain high for the complete frame including stop bit(s). If a Guard Time is programmed in the Control C register (CTRLC.GTIME), the line will remain driven after the last character completion. The following figure shows a transfer with one stop bit and CTRLC.GTIME = 3.

**Figure 32-18.** Example of TE Drive with Guard Time



The Transmit Complete interrupt flag (INTFLAG.TXC) will be raised after the guard time is complete and TE goes low.

### 32.6.3.7 ISO 7816 for Smart Card Interfacing

The SERCOM USART features an ISO/IEC 7816-compatible operating mode. This mode permits interfacing with smart cards and Security Access Modules (SAM) communicating through an ISO 7816 link. Both T = 0 and T = 1 protocols defined by the ISO 7816 specification are supported.

ISO 7816 is available with the following configuration:

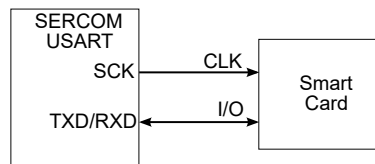
- ISO 7816 format (CTRLA.FORM = 0x07)
- Inverse transmission and reception (CTRLA.RXINV = 1 and CTRLA.TXINV = 1)



- Single bidirectional data line (CTRLA.TXPO and CTRLA.RXPO configured to use the same data pin)
- Even parity (CTRLB.PMODE = 0)
- 8-bit character size (CTRLB.CHSIZE = 0)
- T=0 (CTRLA.CMODE = 1) or T = 1 (CTRLA.CMODE = 0)

ISO 7816 is a half duplex communication on a single bidirectional line. The USART connects to a smart card as shown below. The output is only driven when the USART is transmitting. The USART is considered as the Host of the communication as it generates the clock.

**Figure 32-19.** Connection of a Smart Card to the SERCOM USART



ISO 7816 characters are specified as 8 bits with even parity. The USART must be configured accordingly.

The USART cannot operate concurrently in both receiver and transmitter modes as the communication is unidirectional. It has to be configured according to the required mode by enabling or disabling either the receiver or the transmitter as desired. Enabling both the receiver and the transmitter at the same time in ISO 7816 mode may lead to unpredictable results.

The ISO 7816 specification defines an inverse transmission format. Data bits of the character must be transmitted on the I/O line at their negative value (CTRLA.RXINV = 1 and CTRLA.TXINV = 1).

### Protocol T = 0

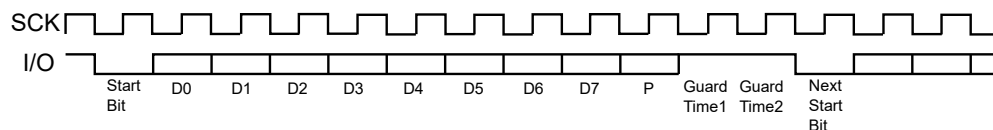
In T = 0 protocol, a character is made up of:

- One start bit
- Eight data bits
- One parity bit
- One guard time, which lasts two bit times

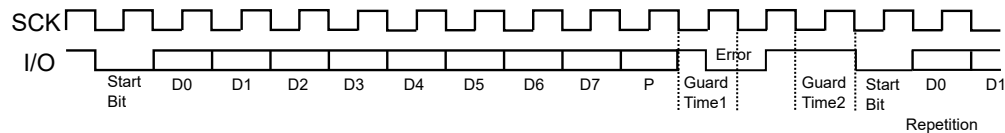
To transmit data in ISO7816, T = 0 protocol mode, the USART is configured in CTRLA.CMODE = 1 communication mode. The transmitter shifts out the bits and does not drive the I/O line during the guard time. Additional guard time can be added by programming the Guard Time (CTRLC.GTIME).

If no parity error is detected, the I/O line remains during the guard time and the transmitter can continue with the transmission of the next character, as shown in the figure below.

**Figure 32-20.** T=0 Protocol without Parity Error



If a parity error is detected by the receiver, it drives the I/O line to 0 during the guard time, as shown in the next figure. This error bit is also named NACK, for Non Acknowledge. In this case, the character lasts 1 bit time more, as the guard time length is the same and is added to the error bit time, which lasts 1 bit time.

**Figure 32-21.** T=0 Protocol with Parity Error

When the USART is the receiver and it detects a parity error, the parity error bit in the Status Register (STATUS.PERR) is set and the character is not written to the receive FIFO.

### Receive Error Counter

The receiver also records the total number of errors (receiver parity errors and NACKs from the remote transmitter) up to a maximum of 255. This can be read in the Receive Error Count (RXERRCNT) register. RXERRCNT is automatically cleared on read.

### Receive NACK Inhibit

The receiver can also be configured to inhibit error generation. This can be achieved by setting the Inhibit Not Acknowledge (CTRLC.INACK) bit. If CTRLC.INACK is 1, no error signal is driven on the I/O line even if a parity error is detected. Moreover, if CTRLC.INACK is set, the erroneous received character is stored in the receive FIFO, and the STATUS.PERR bit is set. Inhibit not acknowledge (CTRLC.INACK) takes priority over disable successive receive NACK (CTRLC.DSNACK).

### Transmit Character Repetition

When the USART is transmitting a character and gets a NACK, it can automatically repeat the character before moving on to the next character. Repetition is enabled by writing the Maximum Iterations register (CTRLC.MAXITER) to a non-zero value. The USART repeats the character the number of times specified in CTRLC.MAXITER.

When the USART repetition number reaches the programmed value in CTRLC.MAXITER, the STATUS.ITER bit is set and the internal iteration counter is reset. If the repetition of the character is acknowledged by the receiver before the maximum iteration is reached, the repetitions are stopped and the iteration counter is cleared.

### Disable Successive Receive NACK

The receiver can limit the number of successive NACKs sent back to the remote transmitter. This is programmed by setting the Disable Successive NACK bit (CTRLC.DSNACK). The maximum number of NACKs transmitted is programmed in the CTRLC.MAXITER field. As soon as the maximum is reached, the character is considered as correct, an acknowledge is sent on the line, the STATUS.ITER bit is set and the internal iteration counter is reset.

### Protocol T = 1

To transmit data in ISO7816, T = 1 protocol mode, the USART is configured in CTRLA.CMODE = 0 communication mode with one or two stop bits. After the stop bits are sent, the transmitter does not drive the I/O line.

Parity is generated when transmitting and checked when receiving. Parity error detection sets the STATUS.PERR bit, and the erroneous character is written to the receive FIFO. When using T = 1 protocol, the receiver does not signal errors on the I/O line and the transmitter does not retransmit.

### 32.6.3.8 Collision Detection

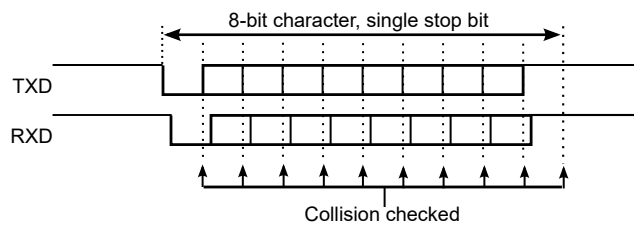
When the receiver and transmitter are connected either through pin configuration or externally, transmit collision can be detected after selecting the Collision Detection Enable bit in the CTRLB register (CTRLB.COLDEN = 1). To detect collision, the receiver and transmitter must be enabled (CTRLB.RXEN = 1 and CTRLB.TXEN = 1).



**Important:** The SERCOM APB clock must always be higher than the SERCOM GCLK Generic Clock to support collision detection.

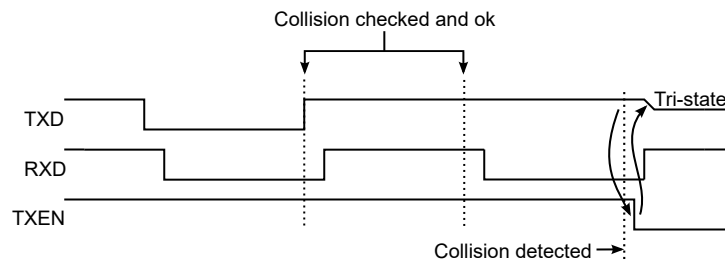
Collision detection is performed for each bit transmitted by comparing the received value with the transmit value, as shown in the figure below. While the transmitter is idle (no transmission in progress), characters can be received on RxD without triggering a collision.

**Figure 32-22.** Collision Checking



The figure below shows the conditions for a collision detection. In this case, the Start bit and the first Data bit are received with the same value as transmitted. The second received Data bit is found to be different than the transmitted bit at the detection point, which indicates a collision.

**Figure 32-23.** Collision Detected



When a collision is detected, the USART follows these steps:

1. Abort the current transfer.
2. Flush the transmit buffer.
3. Disable transmitter (CTRLB.TXEN = 0)
  - This is done after a synchronization delay. The CTRLB Synchronization Busy bit (SYNCBUSY.CTRLB) will be set until this is complete.
  - After disabling, the TxD pin will be tri-stated.
4. Set the Collision Detected bit (STATUS.COLL) along with the Error Interrupt Flag (INTFLAG.ERROR).
5. Set the Transmit Complete Interrupt Flag (INTFLAG.TXC), since the transmit buffer no longer contains data.

After a collision, software must manually enable the transmitter again before continuing, after assuring that the CTRLB Synchronization Busy bit (SYNCBUSY.CTRLB) is not set.

### 32.6.3.9 Loop-Back Mode

For Loop-Back mode, configure the Receive Data Pinout (CTRLA.RXPO) and Transmit Data Pinout (CTRLA.TXPO) to use the same data pins for transmit and receive. The loop-back is through the pad, so the signal is also available externally.

### 32.6.3.10 Start-of-Frame Detection

The USART start-of-frame detector can wake-up the CPU when it detects a Start bit. In Standby Sleep mode, an internal fast start-up oscillator must be selected as the GCLK\_SERCOMx\_CORE source. If the fast startup oscillator is not selected there may be corruption until the oscillator is stable.

When a 1-to-0 transition is detected on RxD, the internal fast start-up oscillator is powered up and the USART clock is enabled. After start-up, the rest of the data frame can be received, provided that the baud rate is slow enough in relation to the fast start-up internal oscillator start-up time. Refer to

the *Electrical Characteristics* chapters for details. The start-up time of this oscillator varies with supply voltage and temperature.

The USART start-of-frame detection works both in Asynchronous and Synchronous modes. It is enabled by writing '1' to the Start of Frame Detection Enable bit in the Control B register (CTRLB.SFDE).

If the Receive Start Interrupt Enable bit in the Interrupt Enable Set register (INTENSET.RXS) is set, the Receive Start interrupt is generated immediately when a start is detected.

When using start-of-frame detection without the Receive Start interrupt, start detection will force the 8 MHz internal oscillator and USART clock active while the frame is being received. In this case, the CPU will not wake up until the receive complete interrupt is generated.

### 32.6.3.11 Sample Adjustment

In Asynchronous mode (CTRLA.CMODE = 0), three samples in the middle are used to determine the value based on majority voting. The three samples used for voting can be selected using the Sample Adjustment bit field in Control A register (CTRLA.SAMPA). When CTRLA.SAMPA = 0, samples 7-8-9 are used for 16x oversampling, and samples 3-4-5 are used for 8x oversampling.

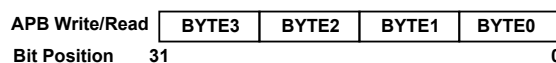
### 32.6.3.12 32-bit Extension

For better system bus utilization, 32-bit data receive and transmit can be enabled separately by writing to the Data 32-bit bit field in the Control C register (CTRLC.DATA32B). When enabled, writes and/or reads to the DATA register are 32 bit in size.

If frames are not multiples of 4 Bytes, the length counter (LENGTH.LEN) and length enable (LENGTH.LENEN) must be configured before data transfer begins, LENGTH.LEN must be enabled only when CTRLC.DATA32B is enabled.

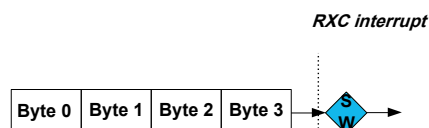
The figure below shows the order of transmit and receive when using 32-bit extension. Bytes are transmitted or received, and stored in order from 0 to 3. Only 8-bit and smaller character sizes are supported. If the character size is less than 8 bits, characters will still be 8-bit aligned within the 32-bit APB write or read. The unused bits within each byte will be zero for received data and unused for transmit data.

Figure 32-24. 32-bit Extension Ordering



A receive transaction using 32-bit extension is in the next figure. The Receive Complete flag (INTFLAG.RXC) is raised every four received Bytes. For transmit transactions, the Data Register Empty flag (INTFLAG.DRE) is raised instead of INTFLAG.RXC.

Figure 32-25. 32-bit Extension Receive Operation



### Data Length Configuration

When the Data Length Enable bit field in the Length register (LENGTH.LENEN) is written to 0x1 or 0x2, the Data Length bit (LENGTH.LEN) determines the number of characters to be transmitted or received from 1 to 255.

**Note:** There is one internal length counter that can be used for either transmit (LENGTH.LENEN=0x1) or receive (LENGTH.LENEN=0x2), but not for both simultaneously.

The LENGTH register must be written before the frame begins. If LENGTH.LEN is not a multiple of 4 Bytes, the final INTFLAG.RXC/DRE interrupt will be raised when the last byte is received/sent. The internal length counter is reset when LENGTH.LEN is reached or when LENGTH.LENEN is written to 0x0.

Writing the LENGTH register while a frame is in progress will produce unpredictable results. If LENGTH.LENEN is not set and a frame is not a multiple of 4 Bytes, the remainder may be lost. Attempting to use the length counter for transmit and receive at the same time will produce unpredictable results.

### 32.6.4 DMA, Interrupts and Events

**Table 32-5.** Module Request for SERCOM USART

Condition	Request		
	DMA	Interrupt	Event
Data Register Empty (DRE)	Yes (request cleared when data is written)	Yes	N/A
Receive Complete (RXC)	Yes (request cleared when data is read)	Yes	
Transmit Complete (TXC)	N/A	Yes	
Receive Start (RXS)	N/A	Yes	
Clear to Send Input Change (CTSIC)	N/A	Yes	
Receive Break (RXBRK)	N/A	Yes	
Error (ERROR)	N/A	Yes	

#### 32.6.4.1 DMA Operation

The USART generates the following DMA requests:

- Data received (RX): The request is set when data is available in the receive FIFO. The request is cleared when DATA is read.
- Data transmit (TX): The request is set when the transmit buffer (TX DATA) is empty. The request is cleared when DATA is written.

#### 32.6.4.2 Interrupts

The USART has the following interrupt sources. These are asynchronous interrupts, and can wake-up the device from any Sleep mode:

- Data Register Empty (DRE)
- Receive Complete (RXC)
- Transmit Complete (TXC)
- Receive Start (RXS)
- Clear to Send Input Change (CTSIC)
- Received Break (RXBRK)
- Error (ERROR)

Each interrupt source has its own Interrupt flag. The Interrupt flag in the Interrupt Flag Status and Clear register (INTFLAG) will be set when the Interrupt condition is met. Each interrupt can be individually enabled by writing '1' to the corresponding bit in the Interrupt Enable Set register (INTENSET), and disabled by writing '1' to the corresponding bit in the Interrupt Enable Clear register (INTENCLR). The status of enabled interrupts can be read from either INTENSET or INTENCLR.

An interrupt request is generated when the Interrupt flag is set and if the corresponding interrupt is enabled. The interrupt request remains active until either the Interrupt flag is cleared, the interrupt

is disabled, or the USART is reset. For details on clearing Interrupt flags, refer to the INTFLAG register description.

The value of INTFLAG indicates which interrupt is executed. Note that interrupts must be globally enabled for interrupt requests. Refer to [Nested Vector Interrupt Controller](#) for details.

### 32.6.5 Sleep Mode Operation

The behavior in Sleep mode is depending on the clock source and the Run In Standby bit in the Control A register (CTRLA.RUNSTDBY):

- Internal clocking, CTRLA.RUNSTDBY = 1: GCLK\_SERCOMx\_CORE can be enabled in all Sleep modes. Any interrupt can wake up the device (except Frame error (FERR) and Parity error (PERR) that are part of the ERROR interrupt).
- External clocking, CTRLA.RUNSTDBY = 1: The Receive Complete interrupt(s) can wake-up the device
- Internal clocking, CTRLA.RUNSTDBY = 0: Internal clock will be disabled, after any ongoing transfer was completed. The Receive Complete interrupt(s) can wake-up the device.
- External clocking, CTRLA.RUNSTDBY = 0: External clock will be disconnected, after any ongoing transfer was completed. All reception will be dropped.

When targeting the lowest STANDBY power consumption for a transmit only application, the Receiver must remain disabled, but the receiver data pinout (CTRLA.RXPO) must be set to match the transmit data pinout (CTRLA.TXPO).

### 32.6.6 Synchronization

Due to asynchronicity between the main clock domain and the peripheral clock domains, some registers must be synchronized when written or read.

The following bits are synchronized when written:

- The Software Reset bit in the CTRLA register (CTRLA.SWRST)
- The Enable bit in the CTRLA register (CTRLA.ENABLE)
- The Receiver Enable bit in the CTRLB register (CTRLB.RXEN)
- The Transmitter Enable bit in the Control B register (CTRLB.TXEN)

**Note:** The CTRLB.RXEN is write-synchronized somewhat differently. Refer to [32.7.2. CTRLB](#) for details.

Required write synchronization is denoted by the "Write-Synchronized" property in the register description.

## 32.7 Register Summary

Offset	Name	Bit Pos.	7	6	5	4	3	2	1	0	
0x00	CTRLA	7:0	RUNSTDBY				MODE[2:0]		ENABLE	SWRST	
		15:8	SAMPR[2:0]					RXINV	TXINV	IBON	
		23:16	SAMPA[1:0]		RXPO[1:0]				TXPO[1:0]		
		31:24		DORD	CPOL	CMODE	FORM[3:0]				
0x04	CTRLB	7:0		SBMODE				CHSIZE[2:0]			
		15:8			PMODE			ENC	SFDE	COLDEN	
		23:16							RXEN	TXEN	
		31:24							LINCMD[1:0]		
0x08	CTRLC	7:0						GTIME[2:0]			
		15:8					HDRDLY[1:0]		BRKLEN[1:0]		
		23:16	MAXITER[2:0]					DSNACK	INACK		
		31:24						DATA32B[1:0]			
0x0C	BAUD	7:0	BAUD[7:0]								
		15:8	BAUD[15:8]								
0x0E	RXPL	7:0	RXPL[7:0]								
0x0F	Reserved										
...	Reserved										
0x13	Reserved										
0x14	INTENCLR	7:0	ERROR		RXBRK	CTSIC	RXS	RXC	TXC	DRE	
0x15	Reserved										
0x16	INTENSET	7:0	ERROR		RXBRK	CTSIC	RXS	RXC	TXC	DRE	
0x17	Reserved										
0x18	INTFLAG	7:0	ERROR		RXBRK	CTSIC	RXS	RXC	TXC	DRE	
0x19	Reserved										
0x1A	STATUS	7:0	ITER	TXE	COLL	ISF	CTS	BUFOVF	FERR	PERR	
		15:8									
0x1C	SYNCBUSY	7:0				LENGTH	RXERRCNT	CTRLB	ENABLE	SWRST	
		15:8									
		23:16									
		31:24									
0x20	RXERRCNT	7:0	RXERRCNT[7:0]								
0x21	Reserved										
0x22	LENGTH	7:0	LEN[7:0]								
		15:8							LENEN[1:0]		
0x24	Reserved										
...	Reserved										
0x27	Reserved										
0x28	DATA	7:0	DATA[7:0]								
		15:8	DATA[15:8]								
		23:16	DATA[23:16]								
		31:24	DATA[31:24]								

### 32.7.1 Control A

**Name:** CTRLA  
**Offset:** 0x00  
**Reset:** 0x00000000  
**Property:** PAC Write-Protection, Enable-Protected Bits, Write-Synchronized Bits

Bit	31	30	29	28	27	26	25	24
		DORD	CPOL	CMODE	FORM[3:0]			
Access		R/W	R/W	R/W	R/W	R/W	R/W	R/W
Reset		0	0	0	0	0	0	0
Bit	23	22	21	20	19	18	17	16
	SAMPA[1:0]		RXPO[1:0]				TXPO[1:0]	
Access	R/W	R/W	R/W	R/W			R/W	R/W
Reset	0	0	0	0			0	0
Bit	15	14	13	12	11	10	9	8
	SAMPR[2:0]					RXINV	TXINV	IBON
Access	R/W	R/W	R/W			R/W	R/W	R/W
Reset	0	0	0			0	0	0
Bit	7	6	5	4	3	2	1	0
	RUNSTDBY			MODE[2:0]			ENABLE	SWRST
Access	R/W			R/W	R/W	R/W	R/W	R/W
Reset	0			0	0	0	0	0

#### Bit 30 – DORD Data Order

This bit selects the data order when a character is shifted out from the Data register.  
This bit is not synchronized.

Value	Description
0	MSB is transmitted first.
1	LSB is transmitted first.

#### Bit 29 – CPOL Clock Polarity

This bit selects the relationship between data output change and data input sampling in synchronous mode.  
This bit is not synchronized.

CPOL	TxD Change	RxD Sample
0x0	Rising XCK edge	Falling XCK edge
0x1	Falling XCK edge	Rising XCK edge

#### Bit 28 – CMODE Communication Mode

This bit selects asynchronous or synchronous communication.  
This bit is not synchronized.

Value	Description
0	Asynchronous communication.
1	Synchronous communication.

#### Bits 27:24 – FORM[3:0] Frame Format

These bits define the frame format.  
These bits are not synchronized.



FORM[3:0]	Description
0x0	USART frame
0x1	USART frame with parity
0x2	LIN Host - Break and sync generation. See LIN Command (CTRLB.LINCMD).
0x3	Reserved
0x4	Auto-baud (LIN Client) - break detection and auto-baud.
0x5	Auto-baud - break detection and auto-baud with parity
0x6	Reserved
0x7	ISO 7816
0x8-0xF	Reserved

**Bits 23:22 – SAMPA[1:0]** Sample Adjustment

These bits define the sample adjustment.  
These bits are not synchronized.

SAMPA[1:0]	16x Over-sampling (CTRLA.SAMPR=0 or 1)	8x Over-sampling (CTRLA.SAMPR=2 or 3)
0x0	7-8-9	3-4-5
0x1	9-10-11	4-5-6
0x2	11-12-13	5-6-7
0x3	13-14-15	6-7-8

**Bits 21:20 – RXPO[1:0]** Receive Data Pinout

These bits define the receive data (RxD) pin configuration.  
These bits are not synchronized.

RXPO[1:0]	Name	Description
0x0	PAD[0]	SERCOM PAD[0] is used for data reception
0x1	PAD[1]	SERCOM PAD[1] is used for data reception
0x2	PAD[2]	SERCOM PAD[2] is used for data reception
0x3	PAD[3]	SERCOM PAD[3] is used for data reception

**Bits 17:16 – TXPO[1:0]** Transmit Data Pinout

These bits define the transmit data (TxD) and XCK pin configurations.  
This bit is not synchronized.

TXPO	TxD Pin Location	XCK Pin Location (When Applicable)	RTS/TE	CTS
0x0	SERCOM PAD[0]	SERCOM PAD[1]	N/A	N/A
0x1	Reserved			
0x2	SERCOM PAD[0]	N/A	SERCOM PAD[2]	SERCOM PAD[3]
0x3	SERCOM_PAD[0]	SERCOM_PAD[1]	SERCOM_PAD[2]	N/A

**Bits 15:13 – SAMPR[2:0]** Sample Rate

These bits select the sample rate.  
These bits are not synchronized.

SAMPR[2:0]	Description
0x0	16x over-sampling using arithmetic baud rate generation.
0x1	16x over-sampling using fractional baud rate generation.
0x2	8x over-sampling using arithmetic baud rate generation.
0x3	8x over-sampling using fractional baud rate generation.
0x4	3x over-sampling using arithmetic baud rate generation.
0x5-0x7	Reserved

**Bit 10 – RXINV** Receive Data Invert

This bit controls whether the receive data (RxD) is inverted or not.

**Notes:**

1. Start, parity and stop bit(s) are unchanged. When enabled, parity is calculated on the inverted data.
2. This field is only valid when using ISO7816 T=0 mode (CTRLA.MODE=0x7).

This bit is not synchronized.

Value	Description
0	RxD is not inverted.
1	RxD is inverted.

**Bit 9 – TXINV** Transmit Data Invert

This bit controls whether the transmit data (TxD) is inverted or not.

**Notes:**

1. Start, parity and stop bit(s) are unchanged. When enabled, parity is calculated on the inverted data.
2. This field is only valid when using ISO7816 T=0 mode (CTRLA.MODE=0x7).

This bit is not synchronized.

Value	Description
0	TxD is not inverted.
1	TxD is inverted.

**Bit 8 – IBON** Immediate Buffer Overflow Notification

This bit controls when the buffer overflow status bit (STATUS.BUFOVF) is asserted when a buffer overflow occurs.

This bit is not synchronized.

Value	Description
0	STATUS.BUFOVF is asserted when it occurs in the data stream.
1	STATUS.BUFOVF is asserted immediately upon buffer overflow.

**Bit 7 – RUNSTDBY** Run In Standby

This bit defines the functionality in standby sleep mode.

This bit is not synchronized.

RUNSTDBY	External Clock	Internal Clock
0x0	External clock is disconnected when ongoing transfer is finished. All reception is dropped.	Generic clock is disabled when ongoing transfer is finished. The device will not wake up on Transfer Complete interrupt unless the appropriate ONDEMAND bits are set in the clocking chain.
0x1	Wake on Receive Complete interrupt.	Generic clock is enabled in all sleep modes. Any interrupt can wake up the device.

**Bits 4:2 – MODE[2:0]** Operating Mode

These bits select the USART serial communication interface of the SERCOM.

These bits are not synchronized.

Value	Description
0x0	USART with external clock
0x1	USART with internal clock

**Bit 1 – ENABLE** Enable

Due to synchronization, there is delay from writing CTRLA.ENABLE until the peripheral is enabled/disabled. The value written to CTRLA.ENABLE will read back immediately and the Enable Synchronization Busy bit in the Synchronization Busy register (SYNCBUSY.ENABLE) will be set. SYNCBUSY.ENABLE is cleared when the operation is complete.

This bit is not enable-protected.

Value	Description
0	The peripheral is disabled or being disabled.

Value	Description
1	The peripheral is enabled or being enabled.

**Bit 0 – SWRST** Software Reset

Writing '0' to this bit has no effect.

Writing '1' to this bit resets all registers in the SERCOM, to their initial state, and the SERCOM will be disabled.

**Note:** Software Reset (CTRLA.SWRST=1) is not functional when the SERCOM is not enabled (CTRLA.ENABLE=0).

Writing '1' to CTRLA.SWRST will always take precedence, meaning that all other writes in the same write-operation will be discarded. Any register write access during the ongoing reset will result in an APB error. Reading any register will return the reset value of the register.

Due to synchronization, there is a delay from writing CTRLA.SWRST until the reset is complete.

CTRLA.SWRST and SYNCBUSY.SWRST will both be cleared when the reset is complete.

**Notes:**

1. When CTRLA.SWRST is written, the user must poll the SYNCBUSY.SWRST bit to know when the reset operation is complete.
2. During a SWRST, access to registers or bits without the SWRST are disallowed until the SYNCBUSY.SWRST bit is cleared by hardware.
3. This bit is not Enable-Protected.

Value	Description
0	There is no reset operation ongoing.
1	The reset operation is ongoing.

### 32.7.2 Control B

**Name:** CTRLB  
**Offset:** 0x04  
**Reset:** 0x00000000  
**Property:** PAC Write-Protection, Enable-Protected Bits, Write-Synchronized Bits

Bit	31	30	29	28	27	26	25	24
							LINCMD[1:0]	
Access							R/W	R/W
Reset							0	0
Bit	23	22	21	20	19	18	17	16
							RXEN	TXEN
Access							R/W	R/W
Reset							0	0
Bit	15	14	13	12	11	10	9	8
			PMODE			ENC	SFDE	COLDEN
Access			R/W			R/W	R/W	R/W
Reset			0			0	0	0
Bit	7	6	5	4	3	2	1	0
	SBMODE					CHSIZE[2:0]		
Access	R/W					R/W	R/W	R/W
Reset	0					0	0	0

#### Bits 25:24 – LINCMD[1:0] LIN Command

These bits define the LIN header transmission control. This field is only valid in LIN Host mode (CTRLA.FORM= LIN Host).

These are strobe bits and will always read back as zero.

These bits are not enable-protected.

Value	Description
0x0	Normal USART transmission.
0x1	Break field is transmitted when DATA is written.
0x2	Break, sync and identifier are automatically transmitted when DATA is written with the identifier.
0x3	Reserved

#### Bit 17 – RXEN Receiver Enable

Writing '0' to this bit will disable the USART receiver. Disabling the receiver will flush the receive buffer and clear the FERR, PERR and BUFOVF bits in the STATUS register.

Writing '1' to CTRLB.RXEN when the USART is disabled will set CTRLB.RXEN immediately. When the USART is enabled, CTRLB.RXEN will be cleared, and SYNCBUSY.CTRLB will be set and remain set until the receiver is enabled. When the receiver is enabled, CTRLB.RXEN will read back as '1'.

Writing '1' to CTRLB.RXEN when the USART is enabled will set SYNCBUSY.CTRLB, which will remain set until the receiver is enabled, and CTRLB.RXEN will read back as '1'.

This bit is not enable-protected.

Value	Description
0	The receiver is disabled or being enabled.
1	The receiver is enabled or will be enabled when the USART is enabled.

#### Bit 16 – TXEN Transmitter Enable

Writing '0' to this bit will disable the USART transmitter. Disabling the transmitter will not become effective until ongoing and pending transmissions are completed.

Writing '1' to CTRLB.TXEN when the USART is disabled will set CTRLB.TXEN immediately. When the USART is enabled, CTRLB.TXEN will be cleared, and SYNCBUSY.CTRLB will be set and remain set until the transmitter is enabled. When the transmitter is enabled, CTRLB.TXEN will read back as '1'. Writing '1' to CTRLB.TXEN when the USART is enabled will set SYNCBUSY.CTRLB, which will remain set until the transmitter is enabled, and CTRLB.TXEN will read back as '1'.

This bit is not enable-protected.

Value	Description
0	The transmitter is disabled or being enabled.
1	The transmitter is enabled or will be enabled when the USART is enabled.

#### Bit 13 – PMODE Parity Mode

This bit selects the type of parity used when parity is enabled (CTRLA.FORM is '1'). The transmitter will automatically generate and send the parity of the transmitted data bits within each frame. The receiver will generate a parity value for the incoming data and parity bit, compare it to the parity mode and, if a mismatch is detected, STATUS.PERR will be set.

This bit is not synchronized.

Value	Description
0	Even parity.
1	Odd parity.

#### Bit 10 – ENC Encoding Format

This bit selects the data encoding format.

This bit is not synchronized.

Value	Description
0	Data is not encoded.
1	Data is IrDA encoded.

#### Bit 9 – SFDE Start of Frame Detection Enable

This bit controls whether the start-of-frame detector will wake up the device when a start bit is detected on the RxD line.

This bit is not synchronized.

SFDE	INTENSET.RXS	INTENSET.RXC	Description
0	X	X	Start-of-frame detection disabled.
1	0	0	Reserved
1	0	1	Start-of-frame detection enabled. RXC wakes up the device from all sleep modes.
1	1	0	Start-of-frame detection enabled. RXS wakes up the device from all sleep modes.
1	1	1	Start-of-frame detection enabled. Both RXC and RXS wake up the device from all sleep modes.

#### Bit 8 – COLDEN Collision Detection Enable

This bit enables collision detection.

This bit is not synchronized.

Value	Description
0	Collision detection is not enabled.
1	Collision detection is enabled.

#### Bit 6 – SBMODE Stop Bit Mode

This bit selects the number of stop bits transmitted.

This bit is not synchronized.

Value	Description
0	One stop bit.
1	Two stop bits.

#### Bits 2:0 – CHSIZE[2:0] Character Size

These bits select the number of bits in a character.

These bits are not synchronized.

CHSIZE[2:0]	Description
0x0	8 bits
0x1	9 bits
0x2-0x4	Reserved
0x5	5 bits
0x6	6 bits
0x7	7 bits

### 32.7.3 Control C

**Name:** CTRLC  
**Offset:** 0x08  
**Reset:** 0x00000000  
**Property:** PAC Write-Protection, Enable-Protected

Bit	31	30	29	28	27	26	25	24
							DATA32B[1:0]	
Access							R/W	R/W
Reset							0	0
Bit	23	22	21	20	19	18	17	16
				MAXITER[2:0]			DSNACK	INACK
Access	R/W		R/W	R/W			R/W	R/W
Reset	0		0	0			0	0
Bit	15	14	13	12	11	10	9	8
				HDRDLY[1:0]			BRKLEN[1:0]	
Access				R/W	R/W	R/W	R/W	
Reset				0	0	0	0	
Bit	7	6	5	4	3	2	1	0
							GTIME[2:0]	
Access							R/W	R/W
Reset							0	0

#### Bits 25:24 – DATA32B[1:0] Data 32 Bit

These bits configure 32-bit Extension for read and write transactions to the DATA register. When disabled, access is according to CTRLB.CHSIZE.

Value	Description
0x0	DATA reads (for received data) and writes (for transmit data) according to CTRLB.CHSIZE.
0x1	DATA reads according to CTRLB.CHSIZE. DATA writes using 32-bit Extension.
0x2	DATA reads using 32-bit Extension. DATA writes according to CTRLB.CHSIZE.
0x3	DATA reads and writes using 32-bit Extension.

#### Bits 22:20 – MAXITER[2:0] Maximum Iterations

These bits define the maximum number of retransmit iterations.

These bits also define the successive NACKs sent to the remote transmitter when CTRLC.DSNACK is set.

This field is only valid when using ISO7816 T=0 mode (CTRLA.MODE=0x7).

#### Bit 17 – DSNACK Disable Successive Not Acknowledge

This bit controls how many times NACK will be sent on parity error reception.

This bit is only valid in ISO7816 T=0 mode and when CTRLC.INACK=0.

Value	Description
0	NACK is sent on the ISO line for every parity error received.
1	Successive parity errors are counted up to the value specified in CTRLC.MAXITER. These parity errors generate a NACK on the ISO line. As soon as this value is reached, no additional NACK is sent on the ISO line.

**Bit 16 – INACK** Inhibit Not Acknowledge

This bit controls whether a NACK is transmitted when a parity error is received. This bit is only valid in ISO7816 T=0 mode.

Value	Description
0	NACK is transmitted when a parity error is received.
1	NACK is not transmitted when a parity error is received.

**Bits 11:10 – HDRDLY[1:0]** LIN Host Header Delay

These bits define the delay between break and sync transmission in addition to the delay between the sync and identifier (ID) fields when in LIN Host mode (CTRLA.FORM = 0x2). This field is only valid when using the LIN header command (CTRLB.LINCMD = 0x2).

**Note:** A correct setting for this bit field must be selected to follow the LIN specification.

Value	Description
0x0	Delay between break and sync transmission is 1 bit time. Delay between sync and ID transmission is 1 bit time.
0x1	Delay between break and sync transmission is 4 bit time. Delay between sync and ID transmission is 4 bit time.
0x2	Delay between break and sync transmission is 8 bit time. Delay between sync and ID transmission is 4 bit time.
0x3	Delay between break and sync transmission is 14 bit time. Delay between sync and ID transmission is 4 bit time.

**Bits 9:8 – BRKLEN[1:0]** LIN Host Break Length

These bits define the length of the break field transmitted when in LIN Host mode (CTRLA.FORM = 0x2).

**Note:** A correct setting for this bit field must be selected to follow the LIN specification.

Value	Description
0x0	Break field transmission is 13 bit times
0x1	Break field transmission is 17 bit times
0x2	Break field transmission is 21 bit times
0x3	Break field transmission is 26 bit times

**Bits 2:0 – GTIME[2:0]** Guard Time

These bits define the guard time when using RS485 mode (CTRLA.FORM = 0x0 or CTRLA.FORM = 0x1, and CTRLA.TXPO=0x3) or ISO7816 mode (CTRLA.FORM = 0x7).

For RS485 mode, the guard time is programmable from 0-7 bit times and defines the time that the transmit enable pin (TE) remains high after the last stop bit is transmitted and there is no remaining data to be transmitted.

For ISO7816 T = 0 mode, the guard time is programmable from 2-9 bit times and defines the guard time between each transmitted byte.



### 32.7.4 Baud

**Name:** BAUD  
**Offset:** 0x0C  
**Reset:** 0x0000  
**Property:** Enable-Protected, PAC Write-Protection

Bit	15	14	13	12	11	10	9	8
	BAUD[15:8]							
Access	R/W	R/W	R/W	R/W	R/W	R/W	R/W	R/W
Reset	0	0	0	0	0	0	0	0
Bit	7	6	5	4	3	2	1	0
	BAUD[7:0]							
Access	R/W	R/W	R/W	R/W	R/W	R/W	R/W	R/W
Reset	0	0	0	0	0	0	0	0

#### Bits 15:0 – BAUD[15:0] Baud Value

Arithmetic Baud Rate Generation (CTRLA.SAMPR[0]=0):

These bits control the clock generation, as described in the SERCOM Baud Rate section.

If Fractional Baud Rate Generation (CTRLA.SAMPR[0]=1 or =3) bit positions 15 to 13 are replaced by FP[2:0] Fractional Part:

- **Bits 15:13 - FP[2:0]: Fractional Part**

These bits control the clock generation, as described in the [SERCOM Clock Generation – Baud-Rate Generator](#) section.

- **Bits 12:0 - BAUD[12:0]: Baud Value**

These bits control the clock generation, as described in the [SERCOM Clock Generation – Baud-Rate Generator](#) section.

### 32.7.5 Receive Pulse Length Register

**Name:** RXPL  
**Offset:** 0x0E  
**Reset:** 0x00  
**Property:** Enable-Protected, PAC Write-Protection

Bit	7	6	5	4	3	2	1	0
	RXPL[7:0]							
Access	R/W	R/W	R/W	R/W	R/W	R/W	R/W	R/W
Reset	0	0	0	0	0	0	0	0

#### Bits 7:0 – RXPL[7:0] Receive Pulse Length

When the encoding format is set to IrDA (CTRLB.ENC=1), these bits control the minimum pulse length that is required for a pulse to be accepted by the IrDA receiver with regards to the serial engine clock period  $SE_{per}$ .

$$PULSE \geq (RXPL + 1) \cdot SE_{per}$$

### 32.7.6 Interrupt Enable Clear

**Name:** INTENCLR  
**Offset:** 0x14  
**Reset:** 0x00  
**Property:** PAC Write-Protection

This register allows the user to disable an interrupt without doing a read-modify-write operation. Changes in this register will also be reflected in the Interrupt Enable Set register (INTENSET).

Bit	7	6	5	4	3	2	1	0
	ERROR		RXBRK	CTSIC	RXS	RXC	TXC	DRE
Access	R/W		R/W	R/W	R/W	R/W	R/W	R/W
Reset	0		0	0	0	0	0	0

#### Bit 7 – ERROR Error Interrupt Enable

Writing '0' to this bit has no effect.

Writing '1' to this bit will clear the Error Interrupt Enable bit, which disables the Error interrupt.

Value	Description
0	Error interrupt is disabled.
1	Error interrupt is enabled.

#### Bit 5 – RXBRK Receive Break Interrupt Enable

Writing '0' to this bit has no effect.

Writing '1' to this bit will clear the Receive Break Interrupt Enable bit, which disables the Receive Break interrupt.

Value	Description
0	Receive Break interrupt is disabled.
1	Receive Break interrupt is enabled.

#### Bit 4 – CTSIC Clear to Send Input Change Interrupt Enable

Writing '0' to this bit has no effect.

Writing '1' to this bit will clear the Clear To Send Input Change Interrupt Enable bit, which disables the Clear To Send Input Change interrupt.

Value	Description
0	Clear To Send Input Change interrupt is disabled.
1	Clear To Send Input Change interrupt is enabled.

#### Bit 3 – RXS Receive Start Interrupt Enable

Writing '0' to this bit has no effect.

Writing '1' to this bit will clear the Receive Start Interrupt Enable bit, which disables the Receive Start interrupt.

Value	Description
0	Receive Start interrupt is disabled.
1	Receive Start interrupt is enabled.

#### Bit 2 – RXC Receive Complete Interrupt Enable

Writing '0' to this bit has no effect.

Writing '1' to this bit will clear the Receive Complete Interrupt Enable bit, which disables the Receive Complete interrupt.

Value	Description
0	Receive Complete interrupt is disabled.
1	Receive Complete interrupt is enabled.

**Bit 1 – TXC** Transmit Complete Interrupt Enable

Writing '0' to this bit has no effect.

Writing '1' to this bit will clear the Transmit Complete Interrupt Enable bit, which disables the Receive Complete interrupt.

Value	Description
0	Transmit Complete interrupt is disabled.
1	Transmit Complete interrupt is enabled.

**Bit 0 – DRE** Data Register Empty Interrupt Enable

Writing '0' to this bit has no effect.

Writing '1' to this bit will clear the Data Register Empty Interrupt Enable bit, which disables the Data Register Empty interrupt.

Value	Description
0	Data Register Empty interrupt is disabled.
1	Data Register Empty interrupt is enabled.

### 32.7.7 Interrupt Enable Set

**Name:** INTENSET  
**Offset:** 0x16  
**Reset:** 0x00  
**Property:** PAC Write-Protection

This register allows the user to disable an interrupt without doing a read-modify-write operation. Changes in this register will also be reflected in the Interrupt Enable Clear register (INTENCLR).

Bit	7	6	5	4	3	2	1	0
	ERROR		RXBRK	CTSIC	RXS	RXC	TXC	DRE
Access	R/W		R/W	R/W	R/W	R/W	R/W	R/W
Reset	0		0	0	0	0	0	0

#### Bit 7 – ERROR Error Interrupt Enable

Writing '0' to this bit has no effect.

Writing '1' to this bit will set the Error Interrupt Enable bit, which enables the Error interrupt.

**Note:** The Frame Error (FERR) and Parity Error (PERR) error interrupts will not wake the device from Standby mode.

Value	Description
0	Error interrupt is disabled.
1	Error interrupt is enabled.

#### Bit 5 – RXBRK Receive Break Interrupt Enable

Writing '0' to this bit has no effect.

Writing '1' to this bit will set the Receive Break Interrupt Enable bit, which enables the Receive Break interrupt.

Value	Description
0	Receive Break interrupt is disabled.
1	Receive Break interrupt is enabled.

#### Bit 4 – CTSIC Clear to Send Input Change Interrupt Enable

Writing '0' to this bit has no effect.

Writing '1' to this bit will set the Clear To Send Input Change Interrupt Enable bit, which enables the Clear To Send Input Change interrupt.

Value	Description
0	Clear To Send Input Change interrupt is disabled.
1	Clear To Send Input Change interrupt is enabled.

#### Bit 3 – RXS Receive Start Interrupt Enable

Writing '0' to this bit has no effect.

Writing '1' to this bit will set the Receive Start Interrupt Enable bit, which enables the Receive Start interrupt.

Value	Description
0	Receive Start interrupt is disabled.
1	Receive Start interrupt is enabled.

#### Bit 2 – RXC Receive Complete Interrupt Enable

Writing '0' to this bit has no effect.

Writing '1' to this bit will set the Receive Complete Interrupt Enable bit, which enables the Receive Complete interrupt.

Value	Description
0	Receive Complete interrupt is disabled.
1	Receive Complete interrupt is enabled.

**Bit 1 – TXC** Transmit Complete Interrupt Enable

Writing '0' to this bit has no effect.

Writing '1' to this bit will set the Transmit Complete Interrupt Enable bit, which enables the Transmit Complete interrupt.

Value	Description
0	Transmit Complete interrupt is disabled.
1	Transmit Complete interrupt is enabled.

**Bit 0 – DRE** Data Register Empty Interrupt Enable

Writing '0' to this bit has no effect.

Writing '1' to this bit will set the Data Register Empty Interrupt Enable bit, which enables the Data Register Empty interrupt.

**Note:** Do not enable DRE interrupt (INTSET.DRE = 1) before entering in Standby Sleep mode.

Value	Description
0	Data Register Empty interrupt is disabled.
1	Data Register Empty interrupt is enabled.

### 32.7.8 Interrupt Flag Status and Clear

**Name:** INTFLAG  
**Offset:** 0x18  
**Reset:** 0x00  
**Property:** -

Bit	7	6	5	4	3	2	1	0
	ERROR		RXBRK	CTSIC	RXS	RXC	TXC	DRE
Access	R/W		R/W	R/W	R/W	R	R/W	R
Reset	0		0	0	0	0	0	0

#### Bit 7 – ERROR Error

This flag is cleared by writing '1' to it.

This bit is set when any error is detected. Errors that will set this flag have corresponding status flags in the STATUS register. Errors that will set this flag are COLL, ISF, BUFOVF, FERR, and PERR. Writing '0' to this bit has no effect.

Writing '1' to this bit will clear the flag.

**Note:** The Frame Error (FERR) and Parity Error (PERR) error interrupts will not wake the device from Standby mode.

#### Bit 5 – RXBRK Receive Break

This flag is cleared by writing '1' to it.

This flag is set when auto-baud is enabled (CTRLA.FORM) and a break character is received.

Writing '0' to this bit has no effect.

Writing '1' to this bit will clear the flag.

#### Bit 4 – CTSIC Clear to Send Input Change

This flag is cleared by writing a '1' to it.

This flag is set when a change is detected on the CTS pin.

Writing '0' to this bit has no effect.

Writing '1' to this bit will clear the flag.

#### Bit 3 – RXS Receive Start

This flag is cleared by writing '1' to it.

This flag is set when a Start condition is detected on the RxD line and start-of-frame detection is enabled (CTRLB.SFDE is '1').

Writing '0' to this bit has no effect.

Writing '1' to this bit will clear the Receive Start Interrupt flag.

#### Bit 2 – RXC Receive Complete

This flag is cleared by reading the Data register (DATA) or by disabling the receiver.

This flag is set when there are unread data in DATA.

Writing '0' to this bit has no effect.

Writing '1' to this bit has no effect.

#### Bit 1 – TXC Transmit Complete

This flag is cleared by writing '1' to it or by writing new data to DATA.

This flag is set when the entire frame in the Transmit Shift register has been shifted out and there are no new data in DATA.

Writing '0' to this bit has no effect.

Writing '1' to this bit will clear the flag.

**Bit 0 – DRE** Data Register Empty

This flag is cleared by writing new data to DATA.

This flag is set when DATA is empty and ready to be written.

Writing '0' to this bit has no effect.

Writing '1' to this bit has no effect.



### 32.7.9 Status

**Name:** STATUS  
**Offset:** 0x1A  
**Reset:** 0x0000  
**Property:** -

Bit	15	14	13	12	11	10	9	8
Access								
Reset								
Bit	7	6	5	4	3	2	1	0
Access	ITER	TXE	COLL	ISF	CTS	BUFOVF	FERR	PERR
Reset	R/W	R/W	R/W	R/W	R	R/W	R/W	R/W
Reset	0	0	0	0	0	0	0	0

#### Bit 7 – ITER Maximum Number of Repetitions Reached

This bit is set when the maximum number of NACK repetitions or retransmissions is met in ISO7816 T=0 mode.

Writing '0' to this bit has no effect.

Writing '1' to this bit will clear it.

#### Bit 6 – TXE Transmitter Empty

When CTRLA.FORM is set to LIN Host mode, this bit is set when any ongoing transmission is complete and TxDATA is empty.

When CTRLA.FORM is not set to LIN Host mode, this bit will always read back as zero.

Writing '0' to this bit has no effect.

Writing '1' to this bit will clear it.

#### Bit 5 – COLL Collision Detected

This bit is cleared by writing '1' to the bit or by disabling the receiver.

This bit is set when collision detection is enabled (CTRLB.COLDEN) and a collision is detected.

Writing '0' to this bit has no effect.

Writing '1' to this bit will clear it.

#### Bit 4 – ISF Inconsistent Sync Field

This bit is cleared by writing '1' to the bit or by disabling the receiver.

This bit is set when the frame format is set to auto-baud (CTRLA.FORM) and a sync field not equal to 0x55 is received.

Writing '0' to this bit has no effect.

Writing '1' to this bit will clear it.

#### Bit 3 – CTS Clear to Send

This bit indicates the current level of the CTS pin when flow control is enabled (CTRLA.TXPO).

Writing '0' to this bit has no effect.

Writing '1' to this bit has no effect.

#### Bit 2 – BUFOVF Buffer Overflow

Reading this bit before reading the Data register will indicate the error status of the next character to be read.

This bit is cleared by writing '1' to the bit or by disabling the receiver.

This bit is set when a buffer overflow condition is detected. A buffer overflow occurs when the receive buffer is full, there is a new character waiting in the receive shift register and a new start bit is detected.

Writing '0' to this bit has no effect.

Writing '1' to this bit will clear it.

**Bit 1 – FERR** Frame Error

Reading this bit before reading the Data register will indicate the error status of the next character to be read.

This bit is cleared by writing '1' to the bit or by disabling the receiver.

This bit is set if the received character had a frame error, i.e., when the first stop bit is zero.

Writing '0' to this bit has no effect.

Writing '1' to this bit will clear it.

**Bit 0 – PERR** Parity Error

Reading this bit before reading the Data register will indicate the error status of the next character to be read.

This bit is cleared by writing '1' to the bit or by disabling the receiver.

This bit is set if parity checking is enabled (CTRLA.FORM is 0x1, 0x5, or 0x7) and a parity error is detected.

Writing '0' to this bit has no effect.

Writing '1' to this bit will clear it.

### 32.7.10 Synchronization Busy

**Name:** SYNCBUSY  
**Offset:** 0x1C  
**Reset:** 0x00000000  
**Property:** -

Bit	31	30	29	28	27	26	25	24
Access								
Reset								
Bit	23	22	21	20	19	18	17	16
Access								
Reset								
Bit	15	14	13	12	11	10	9	8
Access								
Reset								
Bit	7	6	5	4	3	2	1	0
Access				R	R	R	R	R
Reset				0	0	0	0	0
				LENGTH	RXERRCNT	CTRLB	ENABLE	SWRST

#### Bit 4 - LENGTH LENGTH Synchronization Busy

Writing to the LENGTH register requires synchronization. When writing to LENGTH, SYNCBUSY.LENGTH will be set until synchronization is complete. If the LENGTH register is written to while SYNCBUSY.LENGTH is asserted, an APB error is generated.

Value	Description
0	LENGTH synchronization is not busy.
1	LENGTH synchronization is busy.

#### Bit 3 - RXERRCNT Receive Error Count Synchronization Busy

The RXERRCNT register is automatically synchronized to the APB domain upon error. When returning from sleep, this bit will be raised until the new value is available to be read.

Value	Description
0	RXERRCNT synchronization is not busy.
1	RXERRCNT synchronization is busy.

#### Bit 2 - CTRLB CTRLB Synchronization Busy

Writing to the CTRLB register when the SERCOM is enabled requires synchronization. When writing to CTRLB the SYNCBUSY.CTRLB bit will be set until synchronization is complete. If CTRLB is written while SYNCBUSY.CTRLB is asserted, an APB error will be generated.

Value	Description
0	CTRLB synchronization is not busy.
1	CTRLB synchronization is busy.

#### Bit 1 - ENABLE SERCOM Enable Synchronization Busy

Enabling and disabling the SERCOM (CTRLA.ENABLE) requires synchronization. When written, the SYNCBUSY.ENABLE bit will be set until synchronization is complete.

Value	Description
0	Enable synchronization is not busy.
1	Enable synchronization is busy.

**Bit 0 – SWRST** Software Reset Synchronization Busy

Resetting the SERCOM (CTRLA.SWRST) requires synchronization. When written, the SYNCBUSY.SWRST bit will be set until synchronization is complete.

Value	Description
0	SWRST synchronization is not busy.
1	SWRST synchronization is busy.

### 32.7.11 Receive Error Count

**Name:** RXERRCNT  
**Offset:** 0x20  
**Reset:** 0x00  
**Property:** Read-Synchronized

**Note:** This register is read-synchronized: SYNCBUSY.RXERRCNT must be checked to ensure the RXERRCNT register synchronization is complete.

Bit	7	6	5	4	3	2	1	0
	RXERRCNT[7:0]							
Access	R	R	R	R	R	R	R	R
Reset	0	0	0	0	0	0	0	0

#### Bits 7:0 – RXERRCNT[7:0] Receive Error Count

This register records the total number of parity errors and NACK errors combined in ISO7816 mode (CTRLA.FORM=0x7).

This register is automatically cleared on read.

### 32.7.12 Length

**Name:** LENGTH  
**Offset:** 0x22  
**Reset:** 0x00  
**Property:** PAC Write-Protection, Write-Synchronized

**Note:** This register is write-synchronized: SYNCBUSY.LENGTH must be checked to ensure the LENGTH register synchronization is complete.

Bit	15	14	13	12	11	10	9	8
							LENEN[1:0]	
Access							R/W	R/W
Reset							0	0
Bit	7	6	5	4	3	2	1	0
	LEN[7:0]							
Access	R/W	R/W	R/W	R/W	R/W	R/W	R/W	R/W
Reset	0	0	0	0	0	0	0	0

#### Bits 9:8 – LENEN[1:0] Data Length Enable

In 32-bit Extension mode, this bit field configures the length counter either for transmit or receive transactions.

Value	Description
0x0	Length counter disabled
0x1	Length counter enabled for transmit
0x2	Length counter enabled for receive
0x3	Reserved

#### Bits 7:0 – LEN[7:0] Data Length

In 32-bit Extension mode, this bit field configures the data length after which the flags INTFLAG.RXC or INTFLAG.DRE are raised.

Value	Description
0x00	Reserved if LENEN=0x1 or LENEN=0x2
0x01-0xFF	Data Length

**32.7.13 Data**

**Name:** DATA  
**Offset:** 0x28  
**Reset:** 0x0000  
**Property:** -

Bit	31	30	29	28	27	26	25	24
	DATA[31:24]							
Access	R/W	R/W	R/W	R/W	R/W	R/W	R/W	R/W
Reset	0	0	0	0	0	0	0	0
Bit	23	22	21	20	19	18	17	16
	DATA[23:16]							
Access	R/W	R/W	R/W	R/W	R/W	R/W	R/W	R/W
Reset	0	0	0	0	0	0	0	0
Bit	15	14	13	12	11	10	9	8
	DATA[15:8]							
Access	R/W	R/W	R/W	R/W	R/W	R/W	R/W	R/W
Reset	0	0	0	0	0	0	0	0
Bit	7	6	5	4	3	2	1	0
	DATA[7:0]							
Access	R/W	R/W	R/W	R/W	R/W	R/W	R/W	R/W
Reset	0	0	0	0	0	0	0	0

**Bits 31:0 – DATA[31:0] Data**

Reading these bits will return the contents of the Receive Data register. The register should be read only when the Receive Complete Interrupt Flag bit in the Interrupt Flag Status and Clear register (INTFLAG.RXC) is set. The status bits in STATUS should be read before reading the DATA value in order to get any corresponding error.

Writing these bits will write the Transmit Data register. This register should be written only when the Data Register Empty Interrupt Flag bit in the Interrupt Flag Status and Clear register (INTFLAG.DRE) is set.

Reads and writes are 32-bit or CTLB.CHSIZE based on the CTRLC.DATA32B setting.

## 33. SERCOM Serial Peripheral Interface (SERCOM SPI)

### 33.1 Overview

The Serial Peripheral Interface (SPI) is one of the available modes in the [Serial Communication Interface \(SERCOM\)](#).

The SPI uses the SERCOM transmitter and receiver configured as shown in [33.3. Block Diagram](#). Each side, Host and Client, depicts a separate SPI containing a Shift register, a transmit buffer and a two-level receive buffer. In addition, the SPI Host uses the SERCOM baud-rate generator, while the SPI Client can use the SERCOM address match logic. Labels in capital letters are synchronous to CLK\_SERCOMx\_APB and accessible by the CPU, while labels in lowercase letters are synchronous to the SCK clock.

### 33.2 Features

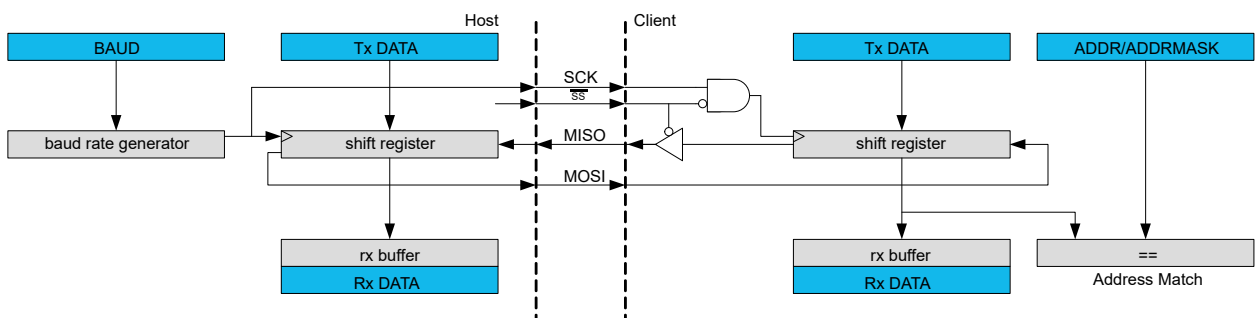
SERCOM SPI includes the following features:

- Full-duplex, four-wire interface (MISO, MOSI, SCK,  $\overline{SS}$ )
- One-level transmit buffer, two-level receive buffer
- Supports all four SPI modes of operation
- Single data direction operation allows alternate function on the MISO or MOSI pin
- Selectable LSB or MSB-first data transfer
- Can be used with DMA
- 32-bit Extension for better system bus utilization
- Host operation:
  - Serial clock speed,  $f_{SCK}=1/t_{SCK}^{(1)}$
  - 8-bit clock generator
  - Optional inter-character spacing
- Client Operation:
  - Serial clock speed,  $f_{SCK}=1/t_{SSCK}^{(1)}$
  - Optional 8-bit address match operation
  - Operation in all sleep modes
  - Wake on  $\overline{SS}$  transition

For  $t_{SCK}$  and  $t_{SSCK}$  values, refer to *SPI Timing Characteristics*.

### 33.3 Block Diagram

Figure 33-1. Full-Duplex SPI Host Client Interconnection





## 33.4 Signal Description

**Table 33-1.** SERCOM SPI Signals

Signal Name	Type	Description
PAD[3:0]	Digital I/O	General SERCOM pins



I/Os for SERCOM peripherals are grouped into I/O sets. For these peripherals, it is mandatory to use I/Os that belong to the same I/O set. The timings are not guaranteed when I/Os from different I/O sets are mixed. Refer to the [Pinout and Packaging](#) chapter to get IOSET definitions.

## 33.5 Peripheral Dependencies

Refer to Section 33.5 [Peripheral Dependencies](#) for more information.

### 33.5.1 I/O Lines

To use the SERCOM's I/O lines, the I/O pins must be configured using the [I/O Pin Controller \(PORT\)](#). When the SERCOM is configured for SPI operation, the SERCOM controls the direction and value of the I/O pins according to the details provided in the table below.

The PORT Control bit (PINCFGn.DRVSTR) is still effective for the SERCOM output pins. The PORT Control bit (PINCFGn.PULLEN) is still effective on the SERCOM input pins, but is limited to the enabling or disabling of a pull down only (it is not possible to enable or disable a pull up).

If the receiver is disabled, the data input pin can be used for other purposes.

**Table 33-2.** SPI Pin Configuration

Pin	Host SPI	Client SPI
MOSI	Output	Input
MISO	Input	Output
SCK	Output	Input
SS	Output	Input

The combined configuration of PORT, the Data In Pinout and the Data Out Pinout bit groups in the Control A register (CTRLA.DIPO and CTRLA.DOPO) define the physical position of the SPI signals in the table above.

## 33.6 Functional Description

### 33.6.1 Principle of Operation

The SPI is a high-speed synchronous data transfer interface. It allows high-speed communication between the device and peripheral devices.

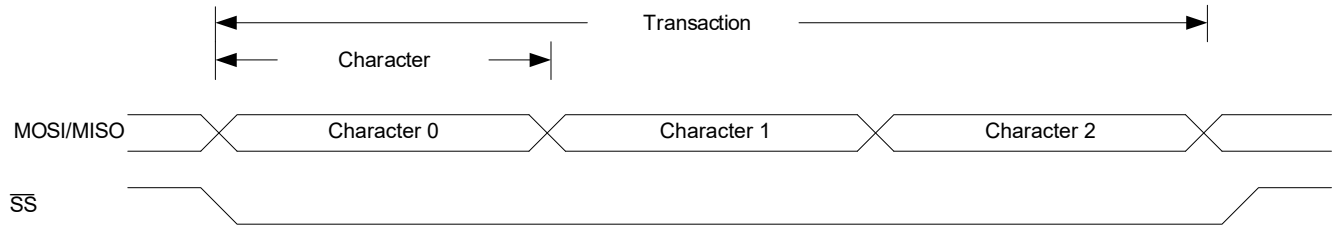
The SPI can operate as Host or Client. As Host, the SPI initiates and controls all data transactions. The SPI is single buffered for transmitting and double buffered for receiving.

When transmitting data, the Data register can be loaded with the next character to be transmitted during the current transmission.

When receiving, the data is transferred to the two-level receive buffer, and the receiver is ready for a new character.

The SPI transaction format is shown in [SPI Transaction Format](#). Each transaction can contain one or more characters. The character size is configurable, and can be either 8 or 9 bits.

**Figure 33-2. SPI Transaction Format**



The SPI Host must pull the SPI select line ( $\overline{SS}$ ) of the desired Client low to initiate a transaction if multiple Clients are connected to the bus. The SPI select line can be wired low if there is only one SPI Client on the bus. The Host and Client prepare data to send through their respective Shift registers, and the Host generates the serial clock on the SCK line.

Data is always shifted from Host to Client on the Host Output Client Input line (MOSI); data is shifted from Client to Host on the Host Input Client Output line (MISO).

Each time character is shifted out from the Host, a character will be shifted out from the Client simultaneously. To signal the end of a transaction, the Host will pull the  $\overline{SS}$  line high.

## 33.6.2 Basic Operation

### 33.6.2.1 Initialization

The following registers are enable-protected, meaning that they can only be written when the SPI is disabled (CTRLA.ENABLE = 0):

- The Control A register (CTRLA), except Enable (CTRLA.ENABLE) and Software Reset (CTRLA.SWRST)
- The Control B register (CTRLB), except Receiver Enable (CTRLB.RXEN)
- The Baud register (BAUD)
- The Address register (ADDR)

When the SPI is enabled or is being enabled (CTRLA.ENABLE = 1), any writing to these registers will be discarded.

When the SPI is being disabled, writing to these registers will be completed after the disabling.

Enable-protection is denoted by the Enable-Protection property in the register description.

Initialize the SPI by following these steps:

1. Select SPI mode in Host/Client operation in the Operating Mode bit group in the CTRLA register (CTRLA.MODE = 0x2 or 0x3).
2. Select Transfer mode for the Clock Polarity bit and the Clock Phase bit in the CTRLA register (CTRLA.CPOL and CTRLA.CPHA) if desired.
3. Select the Frame Format value in the CTRLA register (CTRLA.FORM).
4. Configure the Data In Pinout field in the Control A register (CTRLA.DIPO) for SERCOM pads of the receiver.
5. Configure the Data Out Pinout bit group in the Control A register (CTRLA.DOPO) for SERCOM pads of the transmitter.
6. Select the Character Size value in the CTRLB register (CTRLB.CHSIZE).
7. Write the Data Order bit in the CTRLA register (CTRLA.DORD) for data direction.
8. If the SPI is used in Host mode, select the desired baud rate by writing to the Baud register (BAUD).
9. Enable the receiver by writing the Receiver Enable bit in the CTRLB register (CTRLB.RXEN = 1).

### 33.6.2.2 Enabling, Disabling, and Resetting

This peripheral is enabled by writing '1' to the Enable bit in the Control A register (CTRLA.ENABLE), and disabled by writing '0' to it.

Writing '1' to the Software Reset bit in the Control A register (CTRLA.SWRST) will reset all registers of this peripheral to their initial states, except the DBGCTRL register, and the peripheral is disabled.

**Note:** Software Reset (CTRLA.SWRST=1) is not functional when the SERCOM is not enabled (CTRLA.ENABLE=0).

Refer to the [CTRLA](#) register description for details.

### 33.6.2.3 Clock Generation

In the SPI Host operation (CTRLA.MODE = 0x3), the serial clock (SCK) is generated internally by the SERCOM Baud Rate Generator (BRG).

In SPI mode, the BRG is set to Synchronous mode. The 8-bit Baud register (BAUD) value is used for generating SCK and clocking the Shift register. Refer to [Clock Generation - Baud-Rate Generator](#) for additional information.

In SPI Client operation (CTRLA.MODE is 0x2), the clock is provided by an external Host on the SCK pin. This clock is used to clock the SPI Shift register.

### 33.6.2.4 Data Register

The SPI Transmit Data register (TxDATA) and SPI Receive Data register (RxDATA) share the same I/O address, referred to as the SPI Data register (DATA). Writing DATA register will update the Transmit Data register. Reading the DATA register will return the contents of the Receive Data register.

### 33.6.2.5 SPI Transfer Modes

There are four combinations of SCK phase and polarity to transfer serial data. The SPI Data Transfer modes are shown in [SPI Transfer Modes \(Table\)](#) and [SPI Transfer Modes \(Figure\)](#).

SCK phase is configured by the Clock Phase bit in the CTRLA register (CTRLA.CPHA). SCK polarity is programmed by the Clock Polarity bit in the CTRLA register (CTRLA.CPOL). Data bits are shifted out and latched in on opposite edges of the SCK signal. This ensures sufficient time for the data signals to stabilize.

**Table 33-3.** SPI Transfer Modes

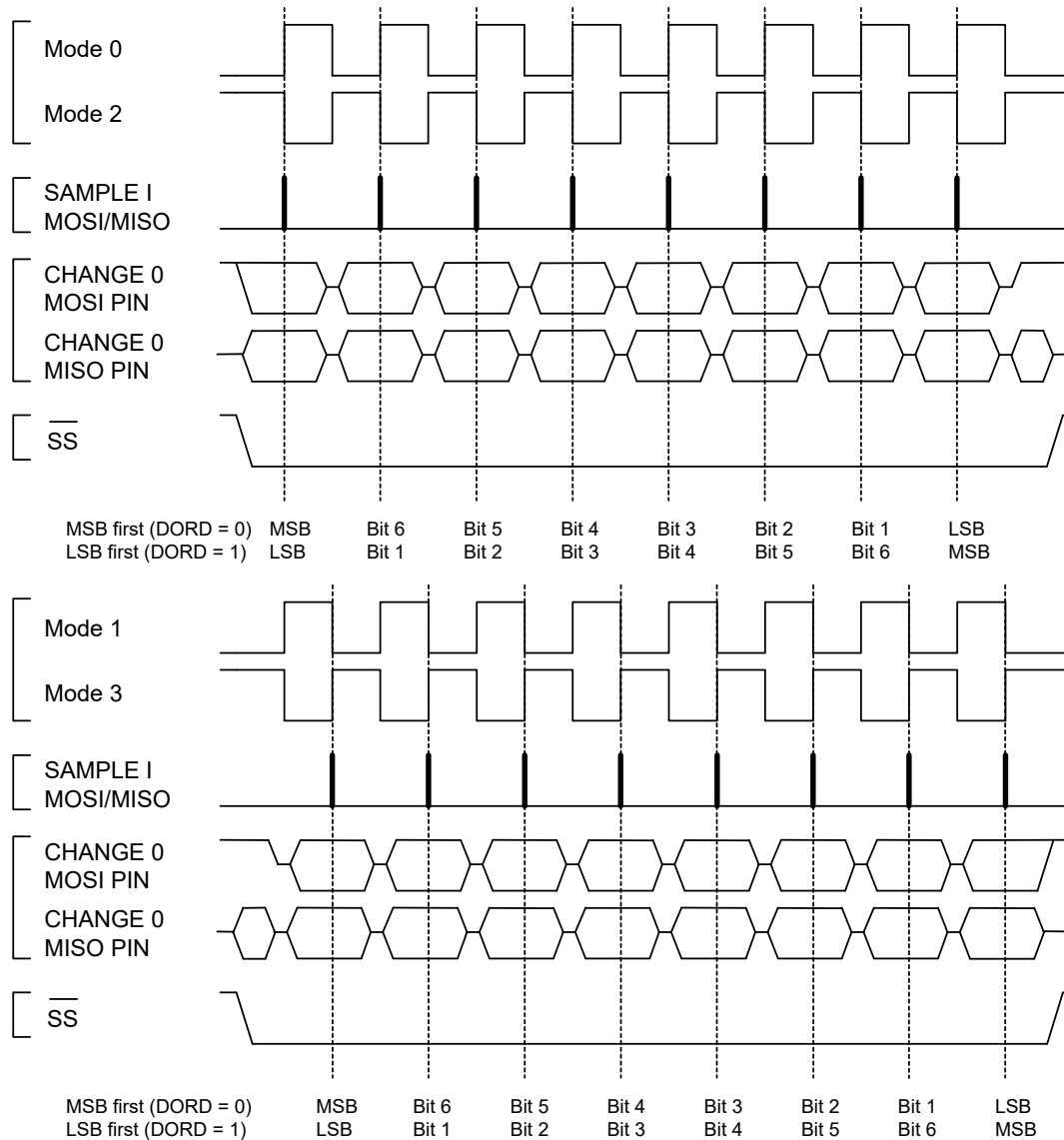
Mode	CPOL	CPHA	Leading Edge	Trailing Edge
0	0	0	Rising, sample	Falling, setup
1	0	1	Rising, setup	Falling, sample
2	1	0	Falling, sample	Rising, setup
3	1	1	Falling, setup	Rising, sample

**Note:**

Leading edge is the first clock edge in a clock cycle.

Trailing edge is the second clock edge in a clock cycle.

Figure 33-3. SPI Transfer Modes



### 33.6.2.6 Transferring Data

#### 33.6.2.6.1 Host

In Host mode, the  $\overline{SS}$  line must be configured as an output.  $\overline{SS}$  can be assigned to any general purpose I/O pin. When the SPI is ready for a data transaction, software must pull the  $\overline{SS}$  line low.

When writing a character to the Data register (DATA), the character will be transferred to the Shift register. Once the content of TxDATA has been transferred to the Shift register, the Data Register Empty flag in the Interrupt Flag Status and Clear register (INTFLAG.DRE) will be set, and a new character can be written to DATA.

Each time one character is shifted out from the Host, another character will be shifted in from the Client simultaneously. If the receiver is enabled (CTRLA.RXEN = 1), the contents of the Shift register will be transferred to the two-level receive buffer. The transfer takes place in the same clock cycle as the last data bit is shifted in. Then the Receive Complete Interrupt flag in the Interrupt Flag Status and Clear register (INTFLAG.RXC) will be set. The received data can be retrieved by reading DATA.

When the last character has been transmitted and there is no valid data in DATA, the Transmit Complete Interrupt flag in the Interrupt Flag Status and Clear register (INTFLAG.TXC) will be set.

When the transaction is finished, the Host must pull the  $\overline{SS}$  line high to notify the Client. The software must pull the  $\overline{SS}$  line high.

### 33.6.2.6.2 Client

In Client mode (CTRLA.MODE = 0x2), the SPI interface will remain inactive with the MISO line tri-stated as long as the  $\overline{SS}$  pin is pulled high. Software may update the contents of DATA at any time as long as the Data Register Empty flag in the Interrupt Status and Clear register (INTFLAG.DRE) is set.

When  $\overline{SS}$  is pulled low and SCK is running, the Client will sample and shift out data according to the Transaction mode set. When the content of TxDATA has been loaded into the Shift register, INTFLAG.DRE will be set, and new data can be written to DATA.

Similar to the Host, the Client will receive one character for each character transmitted. A character will be transferred into the two-level receive buffer within the same clock cycle its last data bit is received. The received character can be retrieved from DATA when the Receive Complete interrupt flag (INTFLAG.RXC) is set.

When the Host pulls the  $\overline{SS}$  line high, the transaction is done and the Transmit Complete Interrupt flag in the Interrupt Flag Status and Clear register (INTFLAG.TXC) will be set.

After DATA is written it takes up to three SCK clock cycles until the content of DATA is ready to be loaded into the Shift register on the next character boundary. As a consequence, the first character transferred in a SPI transaction will not be the content of DATA. This can be avoided by using the preloading feature. Refer to [33.6.3.2. Preloading of the Client Shift Register](#).

When transmitting several characters in one SPI transaction, the data has to be written into DATA register with at least three SCK clock cycles left in the current character transmission. If this criteria is not met, the previously received character will be transmitted.

Once the DATA register is empty, it takes three CLK\_SERCOM\_APB cycles for INTFLAG.DRE to be set.

### 33.6.2.7 Receiver Error Bit

The SPI receiver has one error bit: the Buffer Overflow bit (BUFOVF), which can be read from the Status register (STATUS). Once an error happens, the bit will stay set until it is cleared by writing '1' to it. The bit is also automatically cleared when the receiver is disabled.

There are two methods for buffer overflow notification, selected by the immediate Buffer Overflow Notification bit in the Control A register (CTRLA.IBON):

If CTRLA.IBON=1, STATUS.BUFOVF is raised immediately upon buffer overflow. Software can then empty the receive FIFO by reading RxDATA until the receiver complete Interrupt flag in the Interrupt Flag Status and Clear register (INTFLAG.RXC) goes low.

If CTRLA.IBON=0, the Buffer Overflow condition travels with data through the receive FIFO. After the received data is read, STATUS.BUFOVF and INTFLAG.ERROR will be set along with INTFLAG.RXC, and RxDATA will be zero.

## 33.6.3 Additional Features

### 33.6.3.1 Address Recognition

When the SPI is configured for Client operation (CTRLA.MODE = 0x2) with address recognition (CTRLA.FORM is 0x2), the SERCOM address recognition logic is enabled: the first character in a transaction is checked for an address match.

If there is a match, the Receive Complete Interrupt flag in the Interrupt Flag Status and Clear register (INTFLAG.RXC) is set, the MISO output is enabled, and the transaction is processed. If the device is in Sleep mode, an address match can wake-up the device in order to process the transaction.

If there is no match, the complete transaction is ignored.

If a 9-bit frame format is selected, only the lower 8 bits of the Shift register are checked against the Address register (ADDR).

Preload must be disabled (CTRLB.PLOADEN = 0) in order to use this mode.

### 33.6.3.2 Preloading of the Client Shift Register

When starting a transaction, the Client will first transmit the contents of the shift register before loading new data from DATA. The first character sent can be either the reset value of the shift register (if this is the first transmission since the last reset) or the last character in the previous transmission.

Preloading can be used to preload data into the shift register while  $\overline{SS}$  is high: this eliminates sending a dummy character when starting a transaction. If the shift register is not preloaded, the current contents of the shift register will be shifted out.

Only one data character will be preloaded into the shift register while the synchronized  $\overline{SS}$  signal is high. If the next character is written to DATA before  $\overline{SS}$  is pulled low, the second character will be stored in DATA until transfer begins.

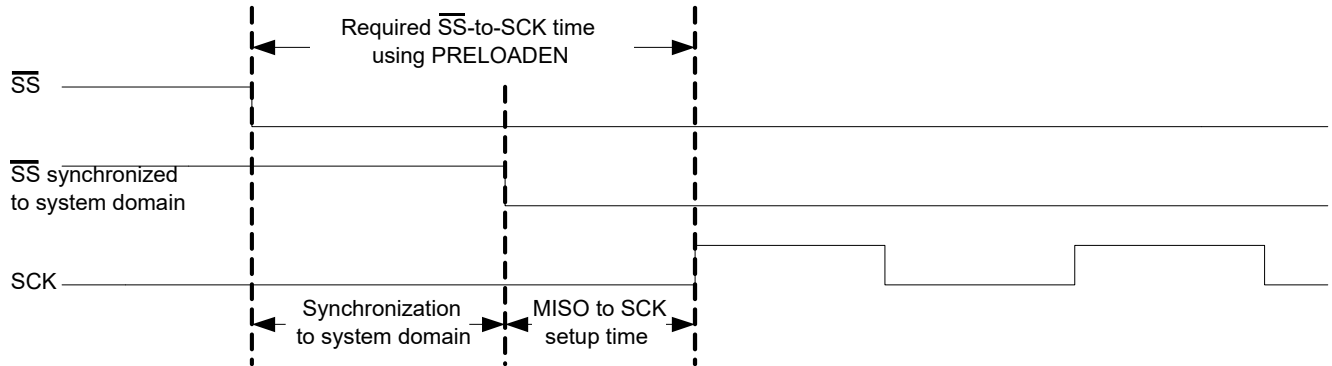
For proper preloading, sufficient time must elapse between  $\overline{SS}$  going low and the first SCK sampling edge, as shown in the following figure. See [55. Electrical Specifications 85°C](#) for timing details.

Preloading is enabled by writing '1' to the Client Data Preload Enable bit in the CTRLB register (CTRLB.PLOADEN).



**Important:** The Preload function must not be used if the Host cannot maintain the  $\overline{SS}$  low until transmission is complete.

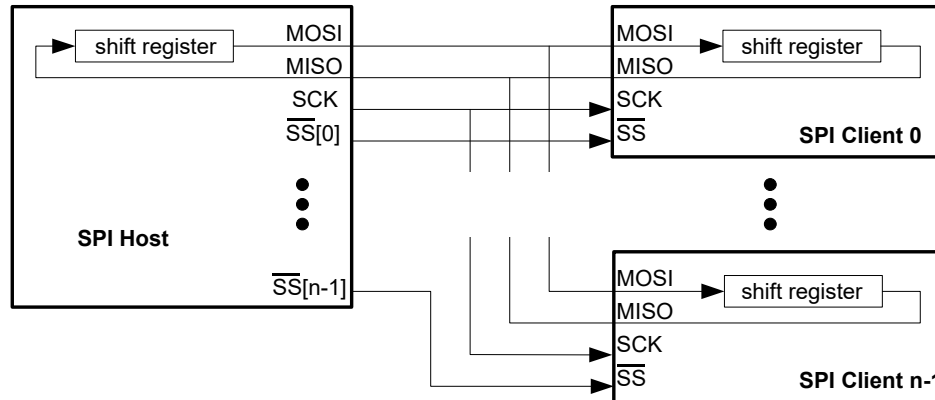
**Figure 33-4.** Timing Using Preloading



### 33.6.3.3 Host with Several Clients

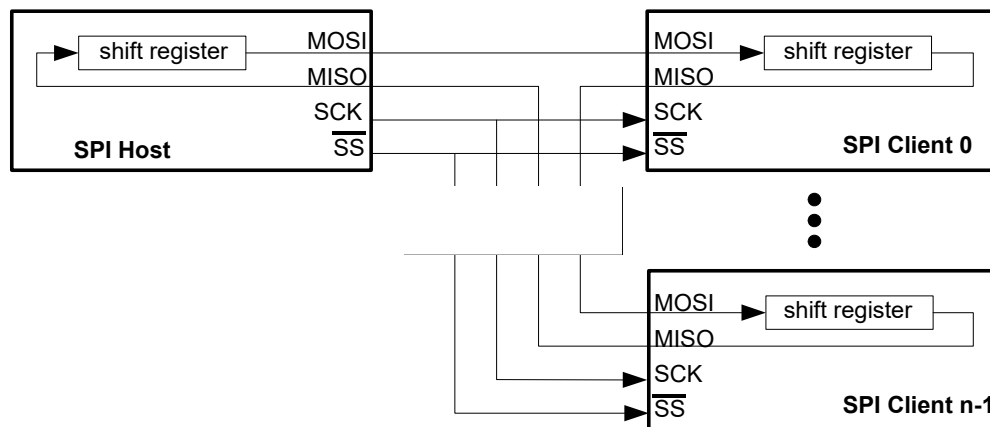
If the bus consists of several SPI Clients, an SPI Host can use general purpose I/O pins to control the  $\overline{SS}$  line to each of the Clients on the bus, as shown in [Multiple Clients in Parallel](#). In this configuration, the single selected SPI Client will drive the tri-state MISO line.

Figure 33-5. Multiple Clients in Parallel



Another configuration is multiple Clients in series, as in [Multiple Clients in Series](#). In this configuration, all n attached Clients are connected in series. A common  $\overline{SS}$  line is provided to all Clients, enabling them simultaneously. The Host must shift n characters for a complete transaction.

Figure 33-6. Multiple Clients in Series



### 33.6.3.4 Loop-Back Mode

For Loop-back mode, configure the Data In Pinout (CTRLA.DIPO) and Data Out Pinout (CTRLA.DOPO) to use the same data pins for transmit and receive. The loop-back is through the pad, so the signal is also available externally.

### 33.6.3.5 SPI Select Low Detection

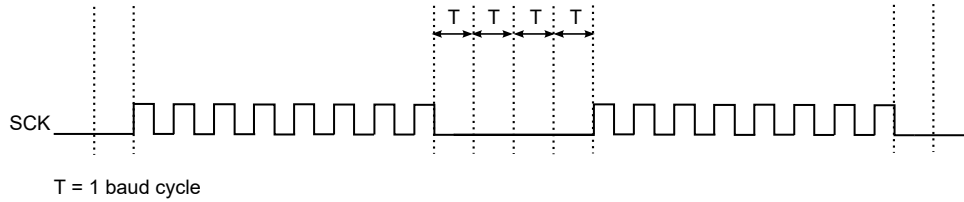
In Client mode, the SPI can wake the CPU when the SPI Select ( $\overline{SS}$ ) goes low. When the SPI Select Low Detect is enabled (CTRLB.SSDE = 1), a high-to-low transition will set the SPI Select Low Interrupt flag (INTFLAG.SSL) and the device will wake-up if applicable.

### 33.6.3.6 Host Inter-Character Spacing

When configured as Host, inter-character spacing can be increased by writing a non-zero value to the Inter-Character Spacing bit field in the Control C register (CTRLC.ICSPACE). When non-zero, CTRLC.ICSPACE represents the minimum number of baud cycles that the SCK clock line does not toggle and the next character is stalled.

The figure gives an example for CTRLC.ICSPACE = 4; In this case, the SCK is inactive for 4 baud cycles.

**Figure 33-7.** Four Cycle Inter-Character Spacing Example



### 33.6.3.7 32-bit Extension

For better system bus utilization, 32-bit data receive and transmit can be enabled by writing to the Data 32-bit bit field in the Control C register (CTRLC.DATA32B = 1). When enabled, write and read transaction to/from the DATA register are 32 bit in size.

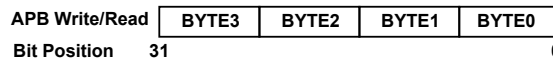
If frames are not multiples of 4 Bytes, the Length Counter (LENGTH.LEN) and Length Enable (LENGTH.LENEN) must be configured before data transfer begins. LENGTH.LEN must be enabled only when CTRLC.DATA32B is enabled.

**Note:** If LENGTH.LENEN = 1, the Inter-Character Spacing bits (CTRLC.ICSPACE) must be written with a non-zero-value.

The following figure shows the order of transmit and receive when using 32-bit mode. Bytes are transmitted or received and stored in order from 0 to 3.

Only 8-bit character size is supported.

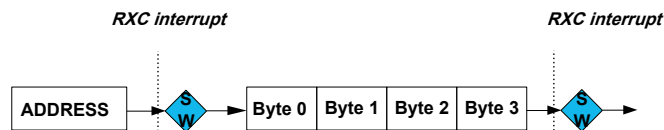
**Figure 33-8.** 32-bit Extension Byte Ordering



### 32-bit Extension Client Operation

The figure below shows a transaction with 32-bit Extension enabled (CTRLC.DATA32B = 1). When address recognition is enabled (CTRLA.FORM = 0x2) and there is an address match, the address is loaded into the FIFO as Byte zero and data begins with Byte 1. INTFLAGS.RXC will then be raised for every 4 Bytes transferred. For transmit, there is a 32-bit holding buffer in the core domain. Once DATA has been registered in the core domain, INTFLAG.DRE will be raised, so that the next 32 bits can be written to the DATA register.

**Figure 33-9.** 32-bit Extension Client Operation



When utilizing the length counter, the LENGTH register must be written before the frame begins. If the frame length while SS is low is not a multiple of LENGTH.LEN Bytes, the Length Error Status bit (STATUS.LENERR) is raised. If LENGTH.LEN is not a multiple of 4 Bytes, the final INTFLAG.RXC interrupt will be raised when the last Byte is received.

The length count is based on the received Bytes, or the number of clocks if the receiver is not enabled. If pre-loading is disabled and DATA is written to for transmit before SCK starts, transmitted data will be delayed by one Byte, but the length counter will still increment for the first (empty) Byte transmission. When the counter reaches LENGTH.LEN, the internal length counter, Rx Byte counter, and Tx Byte counter are reset. If multiple lengths are to be transmitted, INTFLAG.TXC must go high before writing DATA for subsequent lengths.



If there is a Length Error (STATUS.LENERR), the remaining Bytes in the length will be transmitted at the beginning of the next frame. If this is not desired, the SERCOM must be disabled and re-enabled in order to flush the Tx and Rx pipelines.

Writing the LENGTH register while a frame is in progress will produce unpredictable results. If LENGTH.LENEN is not configured and a frame is not a multiple of 4 Bytes (while  $\overline{SS}$  is low), the remainder will be transmitted in the next frame.

### 32-bit Extension Host Operation

When using the SPI configured as Host, the Length and the Length Enable bit fields (LENGTH.LEN and LENGTH.LENEN) must be written before the frame begins. When LENGTH.LENEN is written to '1', the value of LENGTH.LEN determines the number of data bytes in the transaction from 1 to 255.

For receive data, INTFLAG.RXC is raised every 4 Bytes received. If LENGTH.LEN is not a multiple of 4 Bytes, the final INTFLAG.RXC is set when the final byte is received.

For transmit, there is a holding buffer for the 32-bit data in the core domain. Once DATA has been registered in the core domain, INTFLAG.DRE will be raised so that the next 32 bits can be written to the DATA register.

If multiple lengths are to be transmitted, INTFLAG.TXC must go high before writing DATA for subsequent lengths.

## 33.6.4 DMA, Interrupts, and Events

**Table 33-4.** Module Request for SERCOM SPI

Condition	Request		
	DMA	Interrupt	Event
Data Register Empty (DRE)	Yes (request cleared when data is written)	Yes	N/A
Receive Complete (RXC)	Yes (request cleared when data is read)	Yes	
Transmit Complete (TXC)	N/A	Yes	
SPI Select Low (SSL)	N/A	Yes	
Error (ERROR)	N/A	Yes	

### 33.6.4.1 DMA Operation

The SPI generates the following DMA requests:

- Data received (RX): The request is set when data is available in the receive FIFO. The request is cleared when DATA is read.
- Data transmit (TX): The request is set when the transmit buffer (TX DATA) is empty. The request is cleared when DATA is written.

### 33.6.4.2 Interrupts

The SPI has the following interrupt sources. These are asynchronous interrupts, and can wake-up the device from any Sleep mode:

- Data Register Empty (DRE)
- Receive Complete (RXC)
- Transmit Complete (TXC)
- SPI Select Low (SSL)
- Error (ERROR)

Each interrupt source has its own Interrupt flag. The Interrupt flag in the Interrupt Flag Status and Clear register (INTFLAG) will be set when the Interrupt condition is met. Each interrupt can

be individually enabled by writing '1' to the corresponding bit in the Interrupt Enable Set register (INTENSET), and disabled by writing '1' to the corresponding bit in the Interrupt Enable Clear register (INTENCLR). The status of enabled interrupts can be read from either INTENSET or INTENCLR.

An interrupt request is generated when the Interrupt flag is set and if the corresponding interrupt is enabled. The interrupt request remains active until either the Interrupt flag is cleared, the interrupt is disabled, or the SPI is reset. For details on clearing Interrupt flags, refer to the INTFLAG register description.

The value of INTFLAG indicates which interrupt is executed. Note that interrupts must be globally enabled for interrupt requests. Refer to [Nested Vector Interrupt Controller](#) for details.

### 33.6.5 Sleep Mode Operation

The behavior in Sleep mode is depending on the Host/Client configuration and the Run In Standby bit in the Control A register (CTRLA.RUNSTDBY):

- Host operation, CTRLA.RUNSTDBY = 1: The peripheral clock GCLK\_SERCOMx\_CORE will continue to run in Idle mode and in Standby Sleep mode. Any interrupt can wake-up the device.
- Host operation, CTRLA.RUNSTDBY = 0: GLK\_SERCOMx\_CORE will be disabled after the ongoing transaction is finished. Any interrupt can wake up the device.
- Client operation, CTRLA.RUNSTDBY = 1: The Receive Complete interrupt can wake-up the device.
- Client operation, CTRLA.RUNSTDBY = 0: All reception will be dropped, including the ongoing transaction.

### 33.6.6 Synchronization

Due to asynchronicity between the main clock domain and the peripheral clock domains, some registers must be synchronized when written or read.

The following bits are synchronized when written:

- The Software Reset bit in the CTRLA register (CTRLA.SWRST)
- The Enable bit in the CTRLA register (CTRLA.ENABLE)
- The Receiver Enable bit in the CTRLB register (CTRLB.RXEN)

**Note:** The CTRLB.RXEN is write-synchronized somewhat differently. Refer to the [CTRLB](#) register for details.

Required write synchronization is denoted by the "Write-Synchronized" property in the register description.

### 33.7 Register Summary

Offset	Name	Bit Pos.	7	6	5	4	3	2	1	0	
0x00	CTRLA	7:0	RUNSTDBY				MODE[2:0]		ENABLE	SWRST	
		15:8								IBON	
		23:16				DIPO[1:0]				DOPO[1:0]	
		31:24		DORD	CPOL	CPHA		FORM[3:0]			
0x04	CTRLB	7:0		PLOADEN				CHSIZE[2:0]			
		15:8	AMODE[1:0]					SSDE			
		23:16						RXEN			
		31:24									
0x08	CTRLC	7:0			ICSPACE[5:0]						
		15:8									
		23:16									
		31:24								DATA32B	
0x0C	BAUD	7:0	BAUD[7:0]								
0x0D	Reserved										
...											
0x13											
0x14		INTENCLR	7:0	ERROR				SSL	RXC	TXC	DRE
0x15	Reserved										
0x16	INTENSET	7:0	ERROR				SSL	RXC	TXC	DRE	
0x17	Reserved										
0x18	INTFLAG	7:0	ERROR				SSL	RXC	TXC	DRE	
0x19	Reserved										
0x1A	STATUS	7:0						BUFOVF			
		15:8									
0x1C	SYNCBUSY	7:0				LENGTH			CTRLB	ENABLE	SWRST
		15:8									
		23:16									
		31:24									
0x20	Reserved										
...											
0x21											
0x22	LENGTH	7:0	LEN[7:0]								
		15:8								LENEN	
0x24	ADDR	7:0	ADDR[7:0]								
		15:8									
		23:16	ADDRMASK[7:0]								
		31:24									
0x28	DATA	7:0	DATA[7:0]								
		15:8	DATA[15:8]								
		23:16	DATA[23:16]								
		31:24	DATA[31:24]								
0x2C	Reserved										
...											
0x2F											
0x30	DBGCTRL	7:0								DBGSTOP	

### 33.7.1 Control A

**Name:** CTRLA  
**Offset:** 0x00  
**Reset:** 0x00000000  
**Property:** PAC Write-Protection, Enable-Protected Bits, Write-Synchronized Bits

Bit	31	30	29	28	27	26	25	24
		DORD	CPOL	CPHA	FORM[3:0]			
Access		R/W	R/W	R/W	R/W	R/W	R/W	R/W
Reset		0	0	0	0	0	0	0
Bit	23	22	21	20	19	18	17	16
			DIPO[1:0]				DOPO[1:0]	
Access			R/W	R/W			R/W	R/W
Reset			0	0			0	0
Bit	15	14	13	12	11	10	9	8
								IBON
Access								R/W
Reset								0
Bit	7	6	5	4	3	2	1	0
	RUNSTDBY			MODE[2:0]			ENABLE	SWRST
Access	R/W			R/W	R/W	R/W	R/W	R/W
Reset	0			0	0	0	0	0

#### Bit 30 – DORD Data Order

This bit selects the data order when a character is shifted out from the shift register.  
 This bit is not synchronized.

Value	Description
0	MSB is transferred first.
1	LSB is transferred first.

#### Bit 29 – CPOL Clock Polarity

In combination with the Clock Phase bit (CPHA), this bit determines the SPI transfer mode.  
 This bit is not synchronized.

Value	Description
0	SCK is low when idle. The leading edge of a clock cycle is a rising edge, while the trailing edge is a falling edge.
1	SCK is high when idle. The leading edge of a clock cycle is a falling edge, while the trailing edge is a rising edge.

#### Bit 28 – CPHA Clock Phase

In combination with the Clock Polarity bit (CPOL), this bit determines the SPI transfer mode.  
 This bit is not synchronized.

Mode	CPOL	CPHA	Leading Edge	Trailing Edge
0x0	0	0	Rising, sample	Falling, change
0x1	0	1	Rising, change	Falling, sample
0x2	1	0	Falling, sample	Rising, change
0x3	1	1	Falling, change	Rising, sample

Value	Description
0	The data is sampled on a leading SCK edge and changed on a trailing SCK edge.
1	The data is sampled on a trailing SCK edge and changed on a leading SCK edge.

**Bits 27:24 – FORM[3:0]** Frame Format

This bit field selects the various frame formats supported by the SPI in Client mode. When the 'SPI frame with address' format is selected, the first byte received is checked against the ADDR register.

FORM[3:0]	Name	Description
0x0	SPI	SPI frame
0x1	-	Reserved
0x2	SPI_ADDR	SPI frame with address
0x3-0xF	-	Reserved

**Bits 21:20 – DIPO[1:0]** Data In Pinout

These bits define the data in (DI) pad configurations.

In Host operation, DI is MISO.

In Client operation, DI is MOSI.

These bits are not synchronized.

DIPO[1:0]	Name	Description
0x0	PAD[0]	SERCOM PAD[0] is used as data input
0x1	PAD[1]	SERCOM PAD[1] is used as data input
0x2	PAD[2]	SERCOM PAD[2] is used as data input
0x3	PAD[3]	SERCOM PAD[3] is used as data input

**Bits 17:16 – DOPO[1:0]** Data Out Pinout

This bit defines the available pad configurations for data out (DO) and the serial clock (SCK).

In Client operation, the SPI Select ( $\overline{SS}$ ) line is controlled by DOPO (PAD[2]).

In Host operation, the SPI Select ( $\overline{SS}$ ) line is controlled by a GPIO driven by the application.

In Host operation, DO is MOSI.

In Client operation, DO is MISO.

These bits are not synchronized.

DOPO	DO	SCK	Client $\overline{SS}$	Host $\overline{SS}$
0x0	PAD[0]	PAD[1]	PAD[2]	Any GPIO configured by the application
0x1	Reserved			
0x2	PAD[3]	PAD[1]	PAD[2]	Any GPIO configured by the application
0x3	Reserved			

**Bit 8 – IBON** Immediate Buffer Overflow Notification

This bit controls when the buffer overflow status bit (STATUS.BUFOVF) is set when a buffer overflow occurs.

This bit is not synchronized.

Value	Description
0	STATUS.BUFOVF is set when it occurs in the data stream.
1	STATUS.BUFOVF is set immediately upon buffer overflow.

**Bit 7 – RUNSTDBY** Run In Standby

This bit defines the functionality in Standby Sleep mode.

These bits are not synchronized.

RUNSTDBY	Client	Host
0x0	Disabled. All reception is dropped, including the ongoing transaction.	Generic clock is disabled when ongoing transaction is finished. All interrupts can wake up the device.
0x1	Ongoing transaction continues, wake on Receive Complete interrupt.	Generic clock is enabled while in sleep modes. All interrupts can wake up the device.

**Bits 4:2 – MODE[2:0]** Operating Mode

These bits must be written to 0x2 or 0x3 to select the SPI serial communication interface of the SERCOM.

0x2: SPI Client operation  
 0x3: SPI Host operation  
 These bits are not synchronized.

**Bit 1 – ENABLE** Enable

Due to synchronization, there is delay from writing CTRLA.ENABLE until the peripheral is enabled/disabled. The value written to CTRLA.ENABLE will read back immediately and the Synchronization Enable Busy bit in the Synchronization Busy register (SYNCBUSY.ENABLE) will be set. SYNCBUSY.ENABLE is cleared when the operation is complete.

This bit is not enable-protected.

Value	Description
0	The peripheral is disabled or being disabled.
1	The peripheral is enabled or being enabled.

**Bit 0 – SWRST** Software Reset

Writing '0' to this bit has no effect.

Writing '1' to this bit resets all registers in the SERCOM, except DBGCTRL, to their initial state, and the SERCOM will be disabled.

**Note:** Software Reset (CTRLA.SWRST = 1) is not functional when the SERCOM is not enabled (CTRLA.ENABLE = 0).

Writing "1" to the CTRLA.SWRST will always take precedence, meaning that all other writes in the same write-operation will be discarded. Any register write access during the ongoing reset will result in an APB error. Reading any register will return the reset value of the register.

Due to synchronization, there is a delay from writing the CTRLA.SWRST until the reset is complete. The CTRLA.SWRST and SYNCBUSY.SWRST will both be cleared when the reset is complete.

**Notes:**

1. When the CTRLA.SWRST is written, the user must poll the SYNCBUSY.SWRST bit to know when the reset operation is complete.
2. During a SWRST, access to registers/bits without the SWRST are disallowed until the SYNCBUSY.SWRST is cleared by hardware.
3. This bit is not Enable-Protected.

Value	Description
0	There is no reset operation ongoing.
1	The reset operation is ongoing.

### 33.7.2 Control B

**Name:** CTRLB  
**Offset:** 0x04  
**Reset:** 0x00000000  
**Property:** PAC Write-Protection, Enable-Protected Bits, Write-Synchronized Bits

Bit	31	30	29	28	27	26	25	24
Access								
Reset								
Bit	23	22	21	20	19	18	17	16
Access							RXEN	
Reset							0	
Bit	15	14	13	12	11	10	9	8
Access	AMODE[1:0]						SSDE	
Reset	0	0					0	
Bit	7	6	5	4	3	2	1	0
Access		PLOADEN				CHSIZE[2:0]		
Reset		0				0	0	0

#### Bit 17 – RXEN Receiver Enable

Writing '0' to this bit will disable the SPI receiver immediately. The receive buffer will be flushed, data from ongoing receptions will be lost and STATUS.BUFOVF will be cleared.

Writing '1' to CTRLB.RXEN when the SPI is disabled will set CTRLB.RXEN immediately. When the SPI is enabled, CTRLB.RXEN will be cleared, SYNCBUSY.CTRLB will be set and remain set until the receiver is enabled. When the receiver is enabled CTRLB.RXEN will read back as '1'.

Writing '1' to CTRLB.RXEN when the SPI is enabled will set SYNCBUSY.CTRLB, which will remain set until the receiver is enabled, and CTRLB.RXEN will read back as '1'.

This bit is not enable-protected.

Value	Description
0	The receiver is disabled or being enabled.
1	The receiver is enabled or it will be enabled when SPI is enabled.

#### Bits 15:14 – AMODE[1:0] Address Mode

These bits set the Client Addressing mode when the frame format (CTRLA.FORM) with address is used. They are unused in Host mode.

These bits are not synchronized.

AMODE[1:0]	Name	Description
0x0	MASK	ADDRMASK is used as a mask to the ADDR register
0x1	2_ADDR	The Client responds to the two unique addresses in ADDR and ADDRMASK
0x2	RANGE	The Client responds to the range of addresses between and including ADDR and ADDRMASK. ADDR is the upper limit
0x3	-	Reserved

#### Bit 9 – SSDE SPI Select Low Detect Enable

This bit enables wake-up when the SPI Select ( $\overline{SS}$ ) pin transitions from high to low.

This bit is not synchronized.

Value	Description
0	$\overline{SS}$ low detector is disabled.
1	$\overline{SS}$ low detector is enabled.

**Bit 6 - PLOADEN** Client Data Preload Enable

Setting this bit will enable preloading of the Client Shift register when there is no transfer in progress. If the  $\overline{SS}$  line is high when DATA is written, it will be transferred immediately to the Shift register.

This bit is not synchronized.



**Important:** The Preload function must not be used if the Host cannot maintain the  $\overline{SS}$  low until transmission is complete.

**Bits 2:0 - CHSIZE[2:0]** Character Size

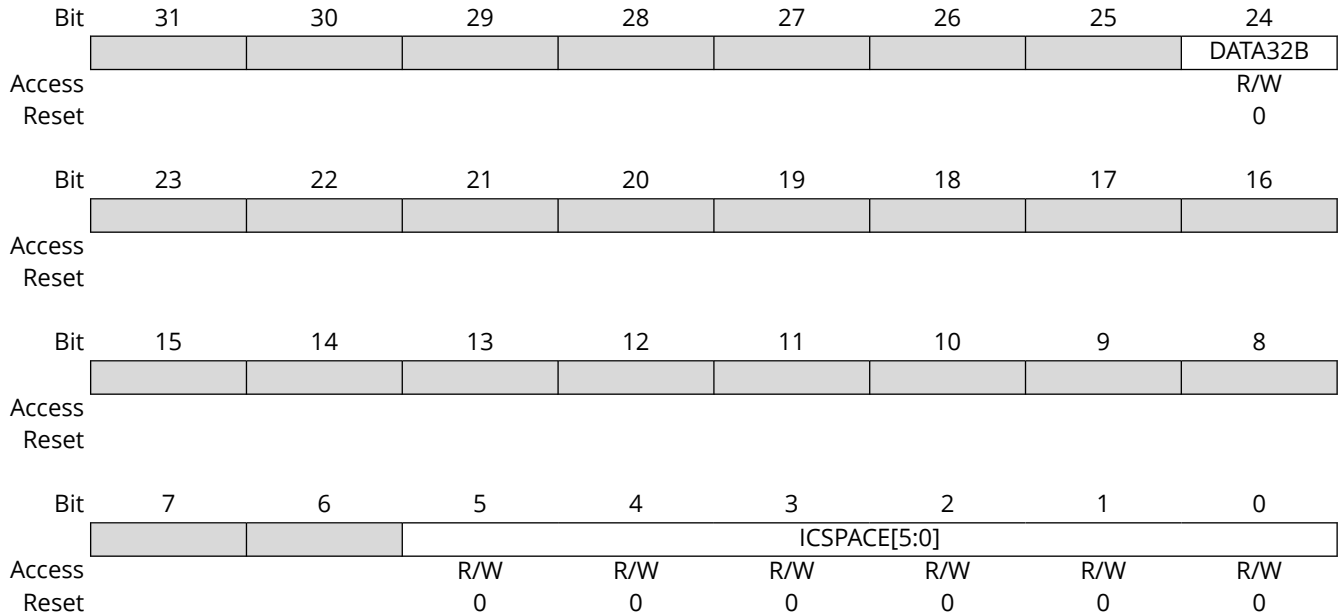
These bits are not synchronized.

CHSIZE[2:0]	Name	Description
0x0	8BIT	8 bits
0x1	9BIT	9 bits
0x2-0x7	-	Reserved



### 33.7.3 Control C

**Name:** CTRLC  
**Offset:** 0x08  
**Reset:** 0x00000000  
**Property:** PAC Write-Protection, Enable-Protected



#### Bit 24 – DATA32B Data 32 Bit

This bit enables 32-bit Extension for read and write transactions to the DATA register. When disabled, access is according to CTRLB.CHSIZE.

Value	Description
0	Transactions from and to DATA register are 8-bit
1	Transactions from and to DATA register are 32-bit

#### Bits 5:0 – ICSPACE[5:0] Inter-Character Spacing

When non-zero, CTRLC.ICSPACE selects the minimum number of baud cycles the SCK line will not toggle between characters.

Value	Description
0x00	Inter-Character Spacing is disabled
0x01–0x3F	The minimum Inter-Character Spacing

### 33.7.4 Baud Rate

**Name:** BAUD  
**Offset:** 0x0C  
**Reset:** 0x00  
**Property:** PAC Write-Protection, Enable-Protected

Bit	7	6	5	4	3	2	1	0
	BAUD[7:0]							
Access	R/W	R/W	R/W	R/W	R/W	R/W	R/W	R/W
Reset	0	0	0	0	0	0	0	0

#### Bits 7:0 – BAUD[7:0] Baud Register

These bits control the clock generation, as described in the [SERCOM Clock Generation – Baud-Rate Generator](#).

### 33.7.5 Interrupt Enable Clear

**Name:** INTENCLR  
**Offset:** 0x14  
**Reset:** 0x00  
**Property:** PAC Write-Protection

This register allows the user to disable an interrupt without read-modify-write operation. Changes in this register will also be reflected in the Interrupt Enable Set register (INTENSET).

Bit	7	6	5	4	3	2	1	0
	ERROR				SSL	RXC	TXC	DRE
Access	R/W				R/W	R/W	R/W	R/W
Reset	0				0	0	0	0

#### Bit 7 – ERROR Error Interrupt Enable

Writing '0' to this bit has no effect.

Writing '1' to this bit will clear the Error Interrupt Enable bit, which disables the Error interrupt.

Value	Description
0	Error interrupt is disabled.
1	Error interrupt is enabled.

#### Bit 3 – SSL SPI Select Low Interrupt Enable

Writing '0' to this bit has no effect.

Writing '1' to this bit will clear the SPI Select Low Interrupt Enable bit, which disables the SPI Select Low interrupt.

Value	Description
0	SPI Select Low interrupt is disabled.
1	SPI Select Low interrupt is enabled.

#### Bit 2 – RXC Receive Complete Interrupt Enable

Writing '0' to this bit has no effect.

Writing '1' to this bit will clear the Receive Complete Interrupt Enable bit, which disables the Receive Complete interrupt.

Value	Description
0	Receive Complete interrupt is disabled.
1	Receive Complete interrupt is enabled.

#### Bit 1 – TXC Transmit Complete Interrupt Enable

Writing '0' to this bit has no effect.

Writing '1' to this bit will clear the Transmit Complete Interrupt Enable bit, which disable the Transmit Complete interrupt.

Value	Description
0	Transmit Complete interrupt is disabled.
1	Transmit Complete interrupt is enabled.

#### Bit 0 – DRE Data Register Empty Interrupt Enable

Writing '0' to this bit has no effect.

Writing '1' to this bit will clear the Data Register Empty Interrupt Enable bit, which disables the Data Register Empty interrupt.

Value	Description
0	Data Register Empty interrupt is disabled.
1	Data Register Empty interrupt is enabled.

### 33.7.6 Interrupt Enable Set

**Name:** INTENSET  
**Offset:** 0x16  
**Reset:** 0x00  
**Property:** PAC Write-Protection

This register allows the user to disable an interrupt without read-modify-write operation. Changes in this register will also be reflected in the Interrupt Enable Clear register (INTENCLR).

Bit	7	6	5	4	3	2	1	0
	ERROR				SSL	RXC	TXC	DRE
Access	R/W				R/W	R/W	R/W	R/W
Reset	0				0	0	0	0

#### Bit 7 – ERROR Error Interrupt Enable

Writing '0' to this bit has no effect.

Writing '1' to this bit will set the Error Interrupt Enable bit, which enables the Error interrupt.

Value	Description
0	Error interrupt is disabled.
1	Error interrupt is enabled.

#### Bit 3 – SSL SPI Select Low Interrupt Enable

Writing '0' to this bit has no effect.

Writing '1' to this bit will set the SPI Select Low Interrupt Enable bit, which enables the SPI Select Low interrupt.

Value	Description
0	SPI Select Low interrupt is disabled.
1	SPI Select Low interrupt is enabled.

#### Bit 2 – RXC Receive Complete Interrupt Enable

Writing '0' to this bit has no effect.

Writing '1' to this bit will set the Receive Complete Interrupt Enable bit, which enables the Receive Complete interrupt.

Value	Description
0	Receive Complete interrupt is disabled.
1	Receive Complete interrupt is enabled.

#### Bit 1 – TXC Transmit Complete Interrupt Enable

Writing '0' to this bit has no effect.

Writing '1' to this bit will set the Transmit Complete Interrupt Enable bit, which enables the Transmit Complete interrupt.

Value	Description
0	Transmit Complete interrupt is disabled.
1	Transmit Complete interrupt is enabled.

#### Bit 0 – DRE Data Register Empty Interrupt Enable

Writing '0' to this bit has no effect.

Writing '1' to this bit will set the Data Register Empty Interrupt Enable bit, which enables the Data Register Empty interrupt.

**Note:** Do not enable DRE interrupt (INTSET.DRE = 1) before entering in Standby Sleep mode.

Value	Description
0	Data Register Empty interrupt is disabled.
1	Data Register Empty interrupt is enabled.

### 33.7.7 Interrupt Flag Status and Clear

**Name:** INTFLAG  
**Offset:** 0x18  
**Reset:** 0x00  
**Property:** -

Bit	7	6	5	4	3	2	1	0
	ERROR				SSL	RXC	TXC	DRE
Access	R/W				R/W	R	R/W	R
Reset	0				0	0	0	0

#### Bit 7 – ERROR Error

This flag is cleared by writing '1' to it.

This bit is set when any error is detected. Errors that will set this flag have corresponding Status flags in the STATUS register. The BUFOVF error and the LENERR error will set this Interrupt flag.

Writing '0' to this bit has no effect.

Writing '1' to this bit will clear the flag.

#### Bit 3 – SSL SPI Select Low

This flag is cleared by writing '1' to it.

This bit is set when a high to low transition is detected on the  $\overline{SS}$  pin in Client mode and SPI Select Low Detect (CTRLB.SSDE) is enabled.

Writing '0' to this bit has no effect.

Writing '1' to this bit will clear the flag.

#### Bit 2 – RXC Receive Complete

This flag is cleared by reading the Data (DATA) register or by disabling the receiver.

This flag is set when there are unread data in the receive buffer. If address matching is enabled, the first data received in a transaction will be an address.

Writing '0' to this bit has no effect.

Writing '1' to this bit has no effect.

#### Bit 1 – TXC Transmit Complete

This flag is cleared by writing '1' to it or by writing new data to DATA.

In Host mode, this flag is set when the data have been shifted out and there are no new data in DATA.

In Client mode, this flag is set when the  $\overline{SS}$  pin is pulled high. If address matching is enabled, this flag is only set if the transaction was initiated with an address match.

Writing '0' to this bit has no effect.

Writing '1' to this bit will clear the flag.

#### Bit 0 – DRE Data Register Empty

This flag is cleared by writing new data to DATA.

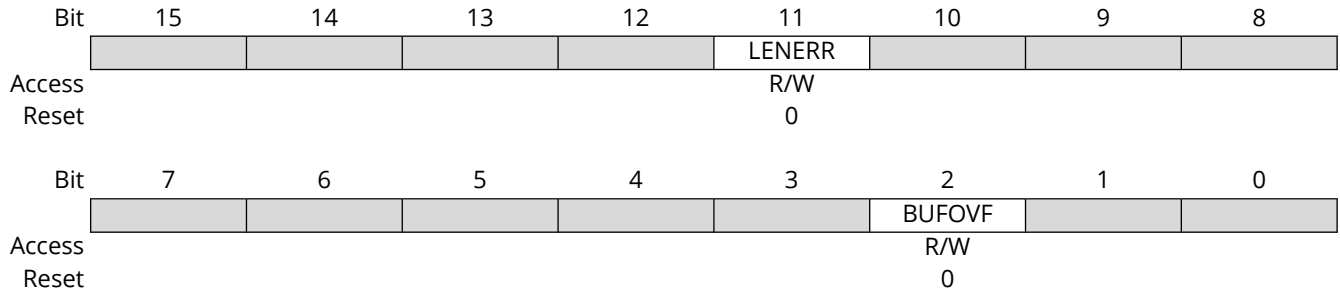
This flag is set when DATA is empty and ready for new data to transmit.

Writing '0' to this bit has no effect.

Writing '1' to this bit has no effect.

### 33.7.8 Status

**Name:** STATUS  
**Offset:** 0x1A  
**Reset:** 0x0000  
**Property:** -



#### Bit 11 – LENERR Transaction Length Error

This bit is set in Client mode when the length counter is enabled (LENGTH.LENEN=1) and the transfer length while  $\overline{SS}$  is low is not a multiple of LENGTH.LEN. Writing '0' to this bit has no effect. Writing '1' to this bit will clear it.

Value	Description
0	No Length Error has occurred.
1	A Length Error has occurred.

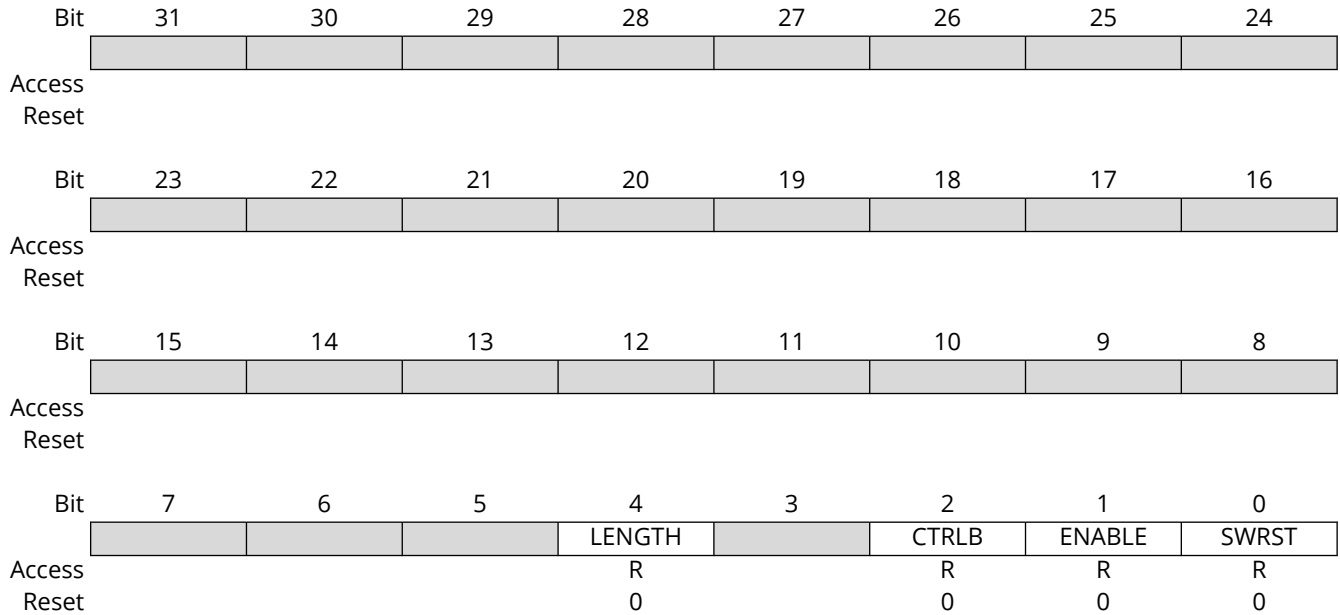
#### Bit 2 – BUFOVF Buffer Overflow

Reading this bit before reading DATA will indicate the error status of the next character to be read. This bit is cleared by writing '1' to the bit or by disabling the receiver. This bit is set when a Buffer Overflow condition is detected. See also CTRLA.IBON for overflow handling. When set, the corresponding RxDATA will be zero. Writing '0' to this bit has no effect. Writing '1' to this bit will clear it.

Value	Description
0	No Buffer Overflow has occurred.
1	A Buffer Overflow has occurred.

### 33.7.9 Synchronization Busy

**Name:** SYNCBUSY  
**Offset:** 0x1C  
**Reset:** 0x00000000  
**Property:** -



#### Bit 4 - LENGTH LENGTH Synchronization Busy

Writing to the LENGTH register requires synchronization. When writing to LENGTH, SYNCBUSY.LENGTH will be set until synchronization is complete. If the LENGTH register is written to while SYNCBUSY.LENGTH is asserted, an APB error is generated.

**Note:** In Client mode, the clock is only running during data transfer, so SYNCBUSY.LENGTH will remain asserted until the next data transfer begins.

Value	Description
0	LENGTH synchronization is not busy.
1	LENGTH synchronization is busy.

#### Bit 2 - CTRLB CTRLB Synchronization Busy

Writing to the CTRLB when the SERCOM is enabled requires synchronization. Ongoing synchronization is indicated by SYNCBUSY.CTRLB=1 until synchronization is complete. If CTRLB is written while SYNCBUSY.CTRLB=1, an APB error will be generated.

Value	Description
0	CTRLB synchronization is not busy.
1	CTRLB synchronization is busy.

#### Bit 1 - ENABLE SERCOM Enable Synchronization Busy

Enabling and disabling the SERCOM (CTRLA.ENABLE) requires synchronization. Ongoing synchronization is indicated by SYNCBUSY.ENABLE=1 until synchronization is complete.

Value	Description
0	Enable synchronization is not busy.
1	Enable synchronization is busy.

**Bit 0 – SWRST** Software Reset Synchronization Busy

Resetting the SERCOM (CTRLA.SWRST) requires synchronization. Ongoing synchronization is indicated by SYNCBUSY.SWRST=1 until synchronization is complete.

Value	Description
0	SWRST synchronization is not busy.
1	SWRST synchronization is busy.



### 33.7.10 Length

**Name:** LENGTH  
**Offset:** 0x22  
**Reset:** 0x0000  
**Property:** PAC Write-Protection, Write-Synchronized

**Note:** This register is write-synchronized: SYNCBUSY.LENGTH must be checked to ensure the LENGTH register synchronization is complete.

Bit	15	14	13	12	11	10	9	8
								LENEN
Access								R/W
Reset								0
Bit	7	6	5	4	3	2	1	0
	LEN[7:0]							
Access	R/W	R/W	R/W	R/W	R/W	R/W	R/W	R/W
Reset	0	0	0	0	0	0	0	0

#### Bit 8 – LENEN Data Length Enable

In 32-bit Extension mode, this bit field enables the length counter.

**Note:** If LENGTH.LENEN = 1, the Inter-Character Spacing bits (CTRLC.ICSPACE) must be written with a non-zero-value.

Value	Description
0	Length counter disabled
1	Length counter enabled

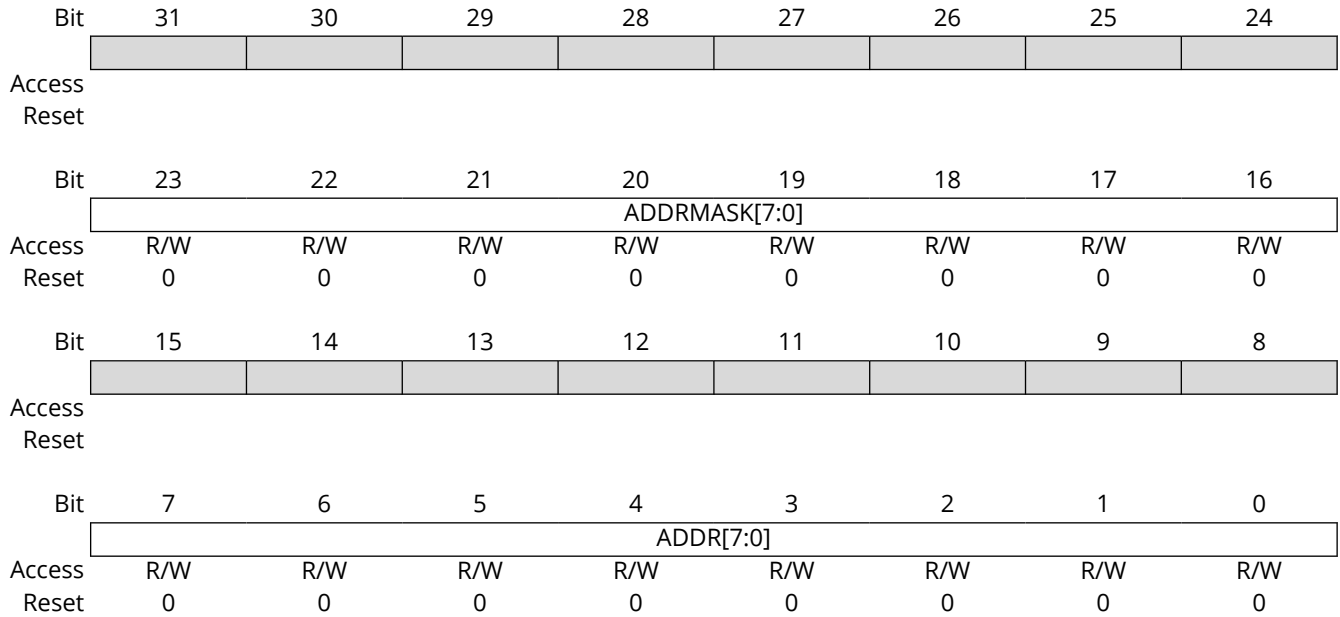
#### Bits 7:0 – LEN[7:0] Data Length

In 32-bit Extension mode, this bit field configures the data length after which the flags INTFLAG.RCX or INTFLAG.DRE are raised.

Value	Description
0x00	Reserved if LENEN=0x1
0x01-0xFF	Data Length

### 33.7.11 Address

**Name:** ADDR  
**Offset:** 0x24  
**Reset:** 0x00000000  
**Property:** PAC Write-Protection, Enable-Protected



#### Bits 23:16 – ADDRMASK[7:0] Address Mask

These bits hold the address mask when the transaction format with address is used (CTRLA.FORM, CTRLB.AMODE).

#### Bits 7:0 – ADDR[7:0] Address

These bits hold the address when the transaction format with address is used (CTRLA.FORM, CTRLB.AMODE).

### 33.7.12 Data

**Name:** DATA  
**Offset:** 0x28  
**Reset:** 0x0000  
**Property:** -

Bit	31	30	29	28	27	26	25	24
	DATA[31:24]							
Access	R/W	R/W	R/W	R/W	R/W	R/W	R/W	R/W
Reset	0	0	0	0	0	0	0	0
Bit	23	22	21	20	19	18	17	16
	DATA[23:16]							
Access	R/W	R/W	R/W	R/W	R/W	R/W	R/W	R/W
Reset	0	0	0	0	0	0	0	0
Bit	15	14	13	12	11	10	9	8
	DATA[15:8]							
Access	R/W	R/W	R/W	R/W	R/W	R/W	R/W	R/W
Reset	0	0	0	0	0	0	0	0
Bit	7	6	5	4	3	2	1	0
	DATA[7:0]							
Access	R/W	R/W	R/W	R/W	R/W	R/W	R/W	R/W
Reset	0	0	0	0	0	0	0	0

#### Bits 31:0 - DATA[31:0] Data

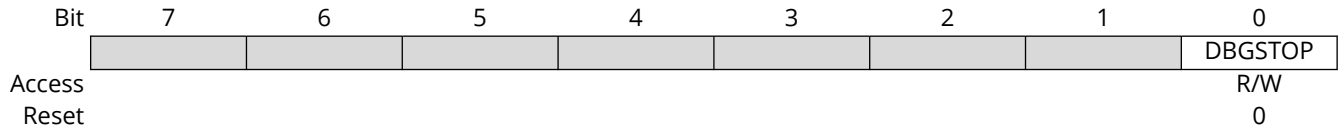
Reading these bits will return the contents of the receive data buffer. The register should be read only when the Receive Complete Interrupt Flag bit in the Interrupt Flag Status and Clear register (INTFLAG.RXC) is set.

Writing these bits will write the transmit data buffer. This register should be written only when the Data Register Empty Interrupt Flag bit in the Interrupt Flag Status and Clear register (INTFLAG.DRE) is set.

Reads and writes are 32-bit or CTRLB.CHSIZE based on the CTRLC.DATA32B setting.

### 33.7.13 Debug Control

**Name:** DBGCTRL  
**Offset:** 0x30  
**Reset:** 0x00  
**Property:** PAC Write-Protection



#### Bit 0 - DBGSTOP Debug Stop Mode

This bit controls the functionality when the CPU is halted by an external debugger.

Value	Description
0	The baud-rate generator continues normal operation when the CPU is halted by an external debugger.
1	The baud-rate generator is halted when the CPU is halted by an external debugger.

## 34. SERCOM Inter-Integrated Circuit (SERCOM I<sup>2</sup>C)

### 34.1 Overview

The Inter-Integrated Circuit (I<sup>2</sup>C) interface is one of the available modes in the [Serial Communication Interface \(SERCOM\)](#).

The I<sup>2</sup>C interface uses the SERCOM transmitter and receiver configured as shown in [Figure 34-1](#). Labels in capital letters are registers accessible by the CPU, while lowercase labels are internal to the SERCOM.

A SERCOM instance can be configured to be either an I<sup>2</sup>C Host or an I<sup>2</sup>C Client. Both Host and Client have an interface containing a Shift register, a transmit buffer and a receive buffer. In addition, the I<sup>2</sup>C Host uses the SERCOM baud-rate generator, while the I<sup>2</sup>C Client uses the SERCOM address match logic.

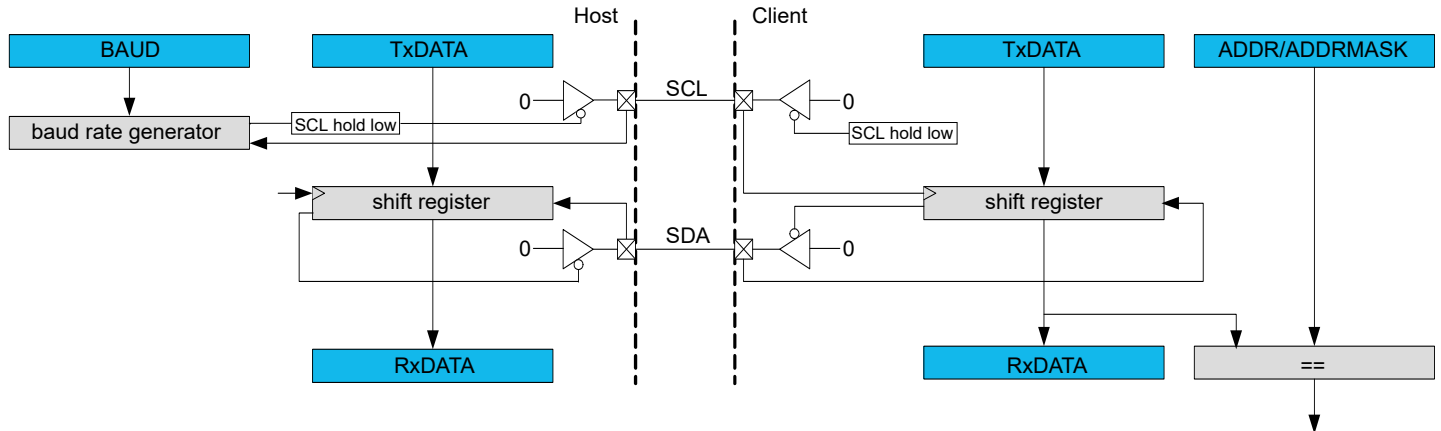
### 34.2 Features

SERCOM I<sup>2</sup>C includes the following features:

- Host or Client Operation
- Can be used with DMA
- Philips I<sup>2</sup>C Compatible
- SMBus Compatible
- PMBus™ Compatible
- Support of 100 kHz and 400 kHz, 1 MHz and 3.4 MHz I<sup>2</sup>C mode
- 32-bit Data Extension for better system bus utilization
- 4-Wire Operation Supported
- Physical interface includes:
  - Slew-rate limited outputs
  - Filtered inputs
- Client Operation:
  - Operation in all Sleep modes
  - Wake-up on address match
  - 7-bit and 10-bit Address match in hardware for:
    - Unique address and/or 7-bit general call address
    - Address range
    - Two unique addresses can be used with DMA

### 34.3 Block Diagram

Figure 34-1. I<sup>2</sup>C Single-Host Single-Client Interconnection



### 34.4 Signal Description

Signal Name	Type	Description
PAD[0]	Digital I/O	SDA
PAD[1]	Digital I/O	SCL

**CAUTION** I/Os for SERCOM peripherals are grouped into I/O sets. For these peripherals, it is mandatory to use I/Os that belong to the same I/O set. The timings are not guaranteed when I/Os from different I/O sets are mixed. Refer to the [Pinout and Packaging](#) chapter to get IOSET definitions.



**Important:** I<sup>2</sup>C is not supported on all SERCOM pins.

The following table lists the SERCOM pins which support I<sup>2</sup>C:

Table 34-1. SERCOM I<sup>2</sup>C Pinout

Package Pin Count	Supply	I/O pins with I <sup>2</sup> C Support
128	VDD	PA08, PA09, PA12, PA13, PA16, PA17, PA22, PA23, PD08, PD09
100	VDD	PA08, PA09, PA12, PA13, PA16, PA17, PA22, PA23
64	VDD	PA08, PA09, PA12, PA13, PA16, PA17, PA22, PA23

### 34.5 Peripheral Dependencies

Refer to Section 33.5 [Peripheral Dependencies](#) for more information.

#### 34.5.1 I/O Lines

In order to use the I/O lines of this peripheral, the I/O pins must be configured using the [I/O Pin Controller \(PORT\)](#).

When the SERCOM is used in I<sup>2</sup>C mode, the SERCOM controls the direction and value of the I/O pins. In I<sup>2</sup>C mode pull-up resistors are disabled. External pull-up resistors are required for proper function.

## 34.6 Functional Description

### 34.6.1 Principle of Operation

The I<sup>2</sup>C interface uses two physical lines for communication:

- Serial Data Line (SDA) for data transfer
- Serial Clock Line (SCL) for the bus clock

A transaction starts with the I<sup>2</sup>C Host sending the Start condition, followed by a 7-bit address and a direction bit (read or write to/from the Client).

The addressed I<sup>2</sup>C Client will then Acknowledge (ACK) the address, and data packet transactions can begin. Every 9-bit data packet consists of 8 data bits followed by a one-bit reply indicating whether the data was acknowledged or not.

If a data packet is Not Acknowledged (NACK), whether by the I<sup>2</sup>C Client or Host, the I<sup>2</sup>C Host takes action by either terminating the transaction by sending the Stop condition, or by sending a repeated start to transfer more data.

The figure below illustrates the possible transaction formats and [Transaction Diagram Symbols](#) explains the transaction symbols. These symbols will be used in the following descriptions.

**Figure 34-2.** Transaction Diagram Symbols

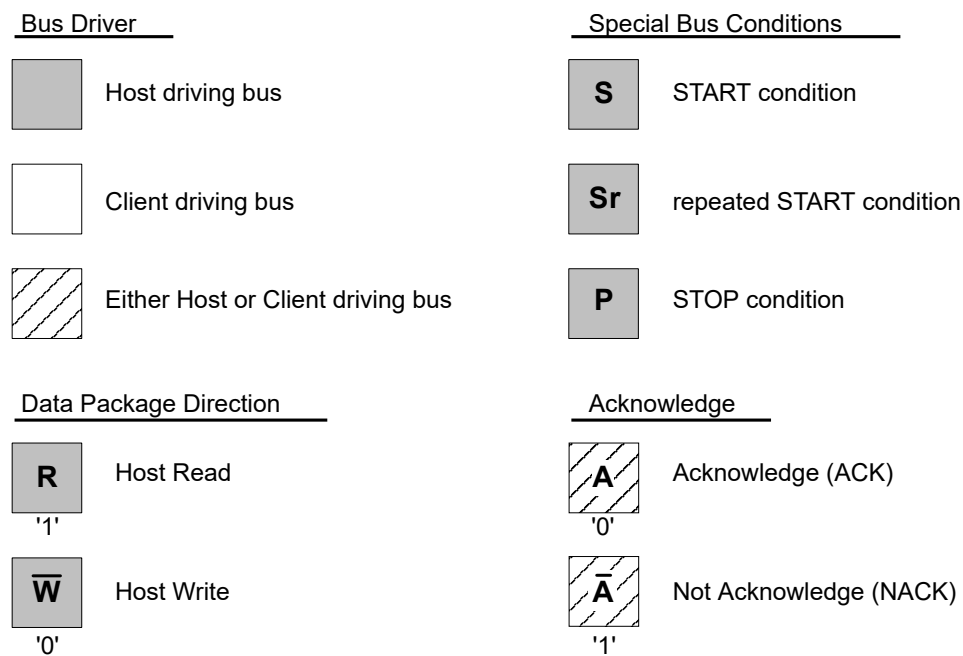
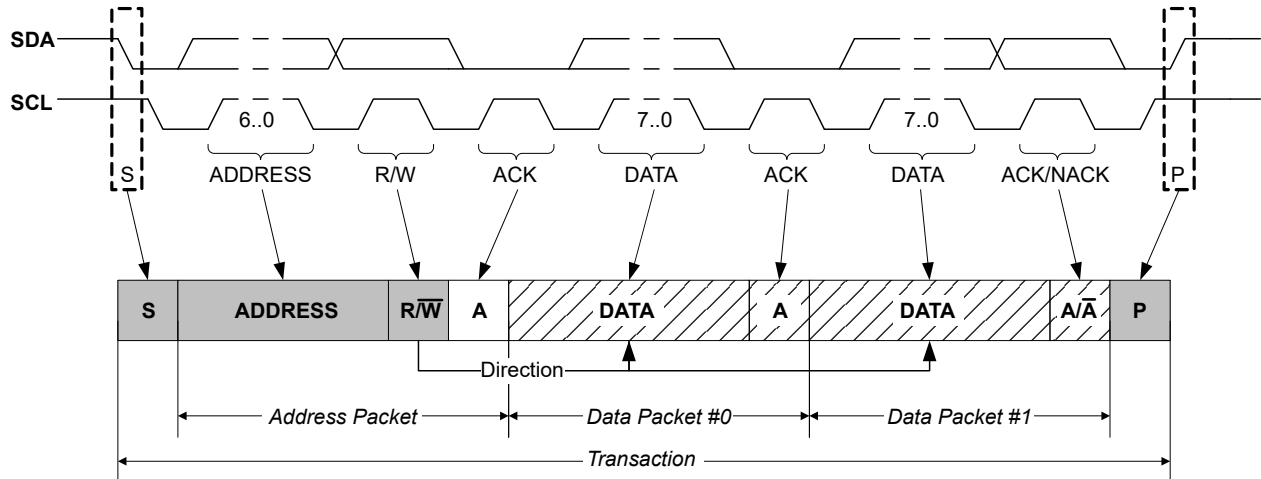


Figure 34-3. Basic I<sup>2</sup>C Transaction Diagram



## 34.6.2 Basic Operation

### 34.6.2.1 Initialization

The following registers are enable-protected, meaning they can be written only when the I<sup>2</sup>C interface is disabled (CTRLA.ENABLE is '0'):

- Control A register (CTRLA), except Enable (CTRLA.ENABLE) and Software Reset (CTRLA.SWRST) bits
- Control B register (CTRLB), except Acknowledge Action (CTRLB.ACKACT) and Command (CTRLB.CMD) bits
- Baud register (BAUD) in Host operation
- Address register (ADDR) in Client operation

When the I<sup>2</sup>C is enabled or is being enabled (CTRLA.ENABLE=1), writing to these registers will be discarded. If the I<sup>2</sup>C is being disabled, writing to these registers will be completed after the disabling.

Enable-protection is denoted by the "Enable-Protection" property in the register description.

Before the I<sup>2</sup>C is enabled it must be configured as outlined by the following steps:

1. Select I<sup>2</sup>C Host or Client mode by writing 0x4 (Client mode) or 0x5 (Host mode) to the Operating Mode bits in the CTRLA register (CTRLA.MODE).
2. If desired, select the SDA Hold Time value in the CTRLA register (CTRLA.SDAHOLD).
3. In Client mode, the minimum Client setup time for the SDA can be selected in the SDA Setup Time bit group in the Control C register (CTRLC.SDASETUP).
4. If desired, enable smart operation by setting the Smart Mode Enable bit in the CTRLB register (CTRLB.SMEN).
5. If desired, enable SCL low time-out by setting the SCL Low Time-Out bit in the Control A register (CTRLA.LOWTOUTEN).
6. In Host mode:
  - a. Select the inactive bus time-out in the Inactive Time-Out bit group in the CTRLA register (CTRLA.INACTOUT).
  - b. Write the Baud Rate register (BAUD) to generate the desired baud rate.

In Client mode:

- a. Configure the address match configuration by writing the Address Mode value in the CTRLB register (CTRLB.AMODE).



- b. Set the Address and Address Mask value in the Address register (ADDR.ADDR and ADDR.ADDRMASK) according to the address configuration.

### 34.6.2.2 Enabling, Disabling, and Resetting

This peripheral is enabled by writing '1' to the Enable bit in the Control A register (CTRLA.ENABLE), and disabled by writing '0' to it.

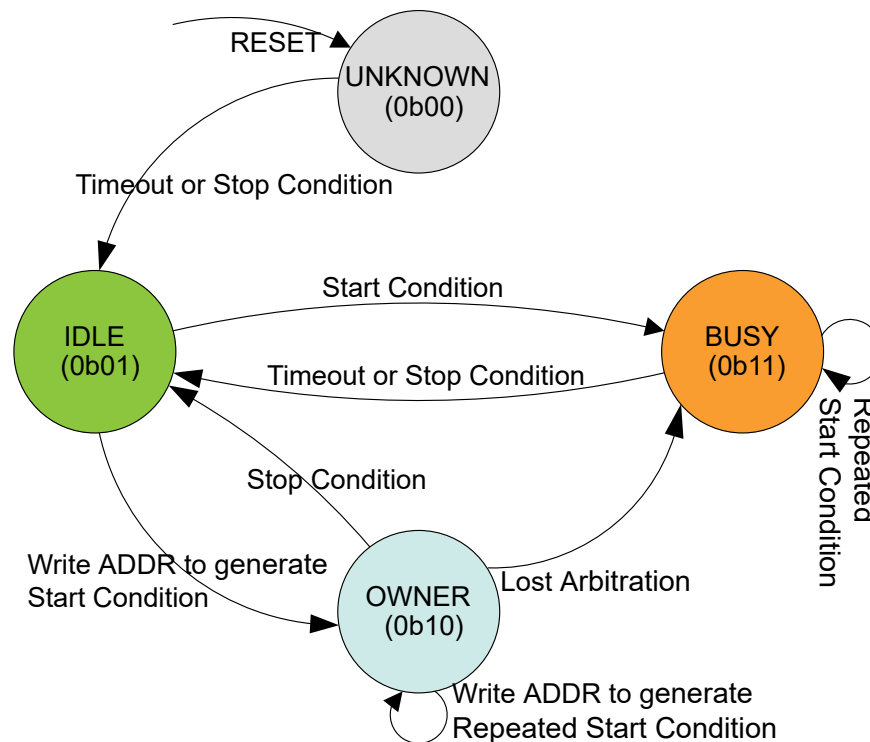
Writing '1' to the Software Reset bit in the Control A register (CTRLA.SWRST) will reset all registers of this peripheral to their initial states, except the DBGCTRL register, and the peripheral is disabled.

**Note:** Software Reset (CTRLA.SWRST=1) is not functional when the SERCOM is not enabled (CTRLA.ENABLE=0).

### 34.6.2.3 I<sup>2</sup>C Bus State Logic

The Bus state logic includes several logic blocks that continuously monitor the activity on the I<sup>2</sup>C bus lines in all Sleep modes with running GCLK\_SERCOM\_x clocks. The start and stop detectors and the bit counter are all essential in the process of determining the current Bus state. The Bus state is determined according to [Bus State Diagram](#). Software can get the current Bus state by reading the Host Bus State bits in the Status register (STATUS.BUSSTATE). The value of STATUS.BUSSTATE in the figure is shown in binary.

Figure 34-4. Bus State Diagram



The Bus state machine is active when the I<sup>2</sup>C Host is enabled.

After the I<sup>2</sup>C Host has been enabled, the Bus state is UNKNOWN (0b00). From the UNKNOWN state, the bus will transition to IDLE (0b01) by either:

- Forcing by writing 0b01 to STATUS.BUSSTATE
- A Stop condition is detected on the bus
- If the inactive bus time-out is configured for SMBus compatibility (CTRLA.INACTOUT) and a time-out occurs.

**Note:** Once a known Bus state is established, the Bus state logic will not re-enter the UNKNOWN state.

When the bus is IDLE it is ready for a new transaction. If a Start condition is issued on the bus by another I<sup>2</sup>C Host in a multi-Host setup, the bus becomes BUSY (0b11). The bus will re-enter IDLE either when a Stop condition is detected, or when a time-out occurs (inactive bus time-out needs to be configured).

If a Start condition is generated internally by writing the Address bit group in the Address register (ADDR.ADDR) while IDLE, the OWNER state (0b10) is entered. If the complete transaction was performed without interference, i.e., arbitration was not lost, the I<sup>2</sup>C Host can issue a Stop condition, which will change the Bus state back to IDLE.

However, if a packet collision is detected while in OWNER state, the arbitration is assumed lost and the Bus state becomes BUSY until a Stop condition is detected. A repeated Start condition will change the Bus state only if arbitration is lost while issuing a repeated start.

**Note:** Violating the protocol may cause the I<sup>2</sup>C to hang. If this happens it is possible to recover from this state by a software Reset (CTRLA.SWRST='1').

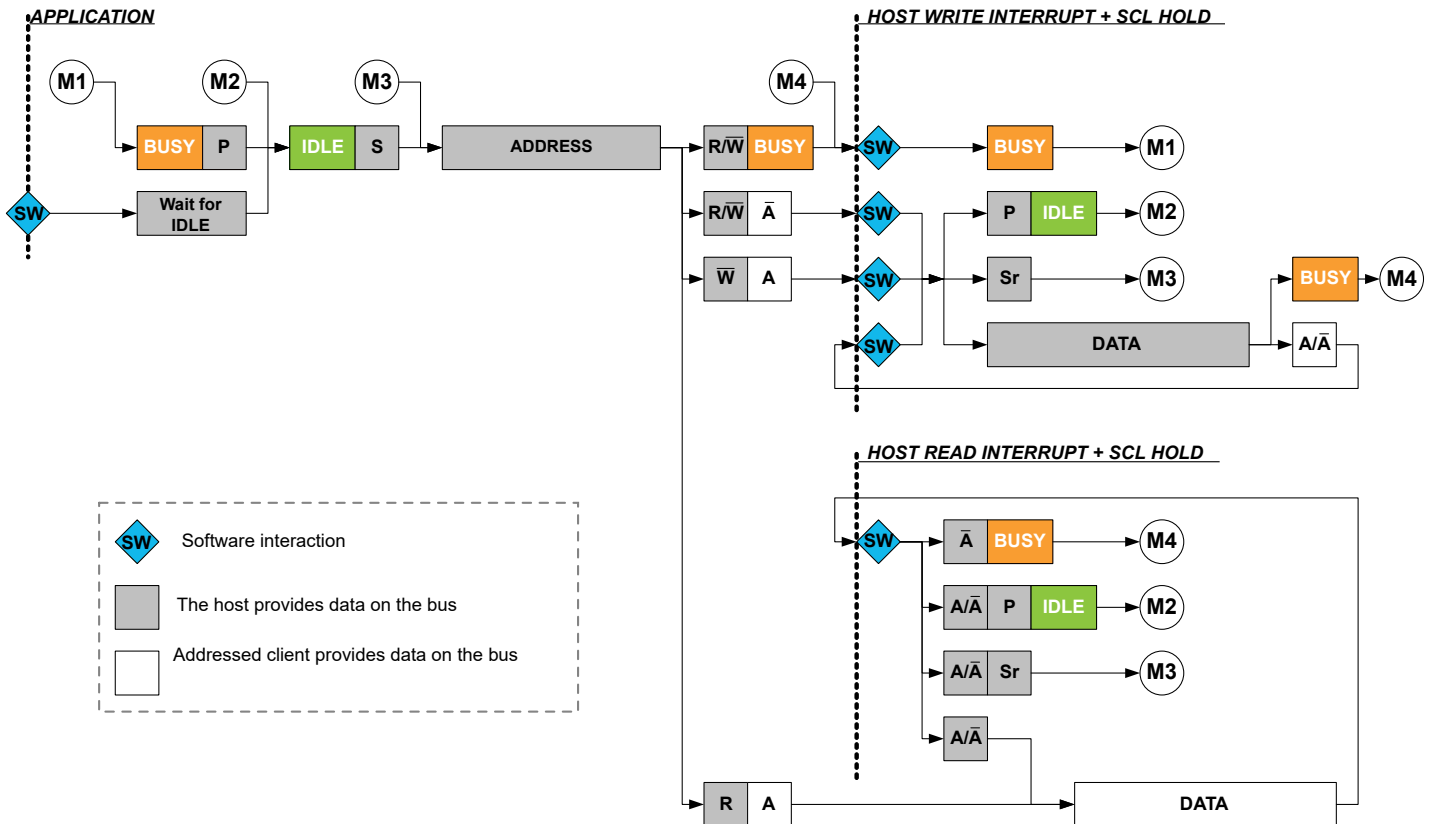
#### 34.6.2.4 I<sup>2</sup>C Host Operation

The I<sup>2</sup>C Host is byte-oriented and interrupt based. The number of interrupts generated is kept at a minimum by automatic handling of most incidents. The software driver complexity and code size are reduced by auto-triggering of operations, and a Special Smart mode, which can be enabled by the Smart Mode Enable bit in the Control B register (CTRLB.SMEN).

When SCL Stretch Mode (CTRLA.SCLSM) is '0', SCL is stretched before or after the Acknowledge bit. In this mode the I<sup>2</sup>C Host operates according to [Host Behavioral Diagram \(SCLSM=0\)](#). The circles labeled "Mn" (M1, M2..) indicate the nodes the bus logic can jump to, based on software or hardware interaction.

This diagram is used as reference for the description of the I<sup>2</sup>C Host operation throughout the document.

Figure 34-5. I<sup>2</sup>C Host Behavioral Diagram



### Host Clock Generation

The SERCOM peripheral supports several I<sup>2</sup>C bidirectional modes:

- Standard mode (*Sm*) up to 100 kHz
- Fast mode (*Fm*) up to 400 kHz

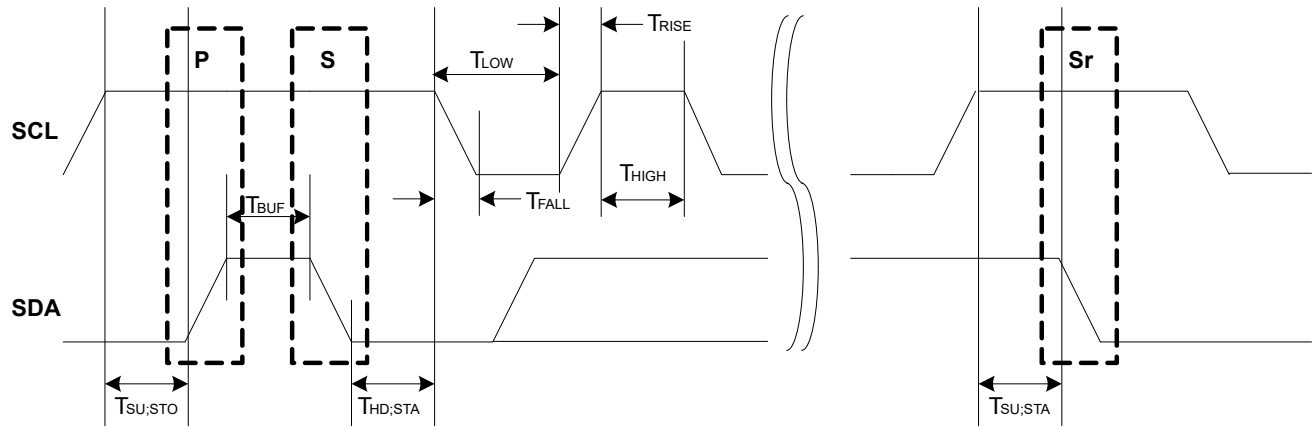
The Host clock configuration for *Sm* and *Fm* are described as follows:

### Clock Generation (Standard-Mode, Fast-Mode, and Fast-Mode Plus)

In I<sup>2</sup>C *Sm* and *Fm* mode, the Host clock (SCL) frequency is determined as described in this section:

The low ( $T_{LOW}$ ) and high ( $T_{HIGH}$ ) times are determined by the Baud Rate register (BAUD), while the rise ( $T_{RISE}$ ) and fall ( $T_{FALL}$ ) times are determined by the bus topology. Because of the wired-AND logic of the bus,  $T_{FALL}$  will be considered as part of  $T_{LOW}$ . Similarly,  $T_{RISE}$  will be in a state between  $T_{LOW}$  and  $T_{HIGH}$  until a high state has been detected.

Figure 34-6. SCL Timing



The following parameters are timed using the SCL low time period  $T_{LOW}$ . This comes from the Host Baud Rate Low bit group in the Baud Rate register (BAUD.BAUDLOW). When BAUD.BAUDLOW=0, or the Host Baud Rate bit group in the Baud Rate register (BAUD.BAUD) determines it.

- $T_{LOW}$  – Low period of SCL clock
- $T_{SU;STO}$  – Set-up time for stop condition
- $T_{BUF}$  – Bus free time between stop and start conditions
- $T_{HD;STA}$  – Hold time (repeated) start condition
- $T_{SU;STA}$  – Set-up time for repeated start condition
- $T_{HIGH}$  is timed using the SCL high time count from BAUD.BAUD
- $T_{RISE}$  is determined by the bus impedance; for internal pull-ups. Refer to *Electrical Characteristics*.
- $T_{FALL}$  is determined by the open-drain current limit and bus impedance; can typically be regarded as zero. Refer to *Electrical Characteristics* for details.

The SCL frequency is given by:

$$f_{SCL} = \frac{1}{T_{LOW} + T_{HIGH} + T_{RISE}}$$

When BAUD.BAUDLOW is zero, the BAUD.BAUD value is used to time both SCL high and SCL low. In this case the following formula will give the SCL frequency:

$$f_{SCL} = \frac{f_{GCLK}}{10 + 2BAUD + f_{GCLK} \cdot T_{RISE}}$$

When BAUD.BAUDLOW is non-zero, the following formula determines the SCL frequency:

$$f_{SCL} = \frac{f_{GCLK}}{10 + BAUD + BAUDLOW + f_{GCLK} \cdot T_{RISE}}$$

The following formulas can determine the SCL  $T_{LOW}$  and  $T_{HIGH}$  times:

$$T_{LOW} = \frac{BAUDLOW + 5}{f_{GCLK}}$$

$$T_{HIGH} = \frac{BAUD + 5}{f_{GCLK}}$$

**Startup Timing** The minimum time between SDA transition and SCL rising edge is 6 APB cycles when the DATA register is written in smart mode. If a greater startup time is required due to long rise times, the time between DATA write and IF clear must be controlled by software.

**Note:** When timing is controlled by user, the Smart Mode cannot be enabled.

### Transmitting Address Packets

The I<sup>2</sup>C Host starts a bus transaction by writing the I<sup>2</sup>C Client address to ADDR.ADDR and the direction bit, as described in 34.6.1. Principle of Operation. If the bus is busy, the I<sup>2</sup>C Host will wait until the bus becomes idle before continuing the operation. When the bus is idle, the I<sup>2</sup>C Host will issue a start condition on the bus. The I<sup>2</sup>C Host will then transmit an address packet using the address written to ADDR.ADDR. After the address packet has been transmitted by the I<sup>2</sup>C Host, one of four cases will arise according to arbitration and transfer direction.

#### Case 1: Arbitration lost or bus error during address packet transmission

If arbitration was lost during transmission of the address packet, the Host on Bus bit in the Interrupt Flag Status and Clear register (INTFLAG.MB) and the Arbitration Lost bit in the Status register (STATUS.ARBLOST) are both set. Serial data output to SDA is disabled, and the SCL is released, which disables clock stretching. In effect the I<sup>2</sup>C Host is no longer allowed to execute any operation on the bus until the bus is idle again. A bus error will behave similarly to the arbitration lost condition. In this case, the MB interrupt flag and Host Bus Error bit in the Status register (STATUS.BUSERR) are both set in addition to STATUS.ARBLOST.

The Host Received Not Acknowledge bit in the Status register (STATUS.RXNACK) will always contain the last successfully received acknowledge or not acknowledge indication.

In this case, software will typically inform the application code of the condition and then clear the interrupt flag before exiting the interrupt routine. No other flags have to be cleared at this moment, because all flags will be cleared automatically the next time the ADDR.ADDR register is written.

#### Case 2: Address packet transmit complete – No ACK received

If there is no I<sup>2</sup>C Client device responding to the address packet, then the INTFLAG.MB interrupt flag and STATUS.RXNACK will be set. The clock hold is active at this point, preventing further activity on the bus.

The missing ACK response can indicate that the I<sup>2</sup>C Client is busy with other tasks or sleeping. Therefore, it is not able to respond. In this event, the next step can be either issuing a stop condition (recommended) or resending the address packet by a repeated start condition. When using SMBus logic, the Client must ACK the address. If there is no response, it means that the Client is not available on the bus.

#### Case 3: Address packet transmit complete – Write packet, Host on Bus set

If the I<sup>2</sup>C Host receives an acknowledge response from the I<sup>2</sup>C Client, INTFLAG.MB will be set and STATUS.RXNACK will be cleared. The clock hold is active at this point, preventing further activity on the bus.

In this case, the software implementation becomes highly protocol dependent. Three possible actions can enable the I<sup>2</sup>C operation to continue:

- Initiate a data transmit operation by writing the data byte to be transmitted into DATA.DATA.
- Transmit a new address packet by writing ADDR.ADDR. A repeated start condition will automatically be inserted before the address packet.
- Issue a stop condition, consequently terminating the transaction.

#### Case 4: Address packet transmit complete – Read packet, Client on Bus set

If the I<sup>2</sup>C Host receives an ACK from the I<sup>2</sup>C Client, the I<sup>2</sup>C Host proceeds to receive the next byte of data from the I<sup>2</sup>C Client. When the first data byte is received, the Client on Bus bit in the Interrupt Flag register (INTFLAG.SB) will be set and STATUS.RXNACK will be cleared. The clock hold is active at this point, preventing further activity on the bus.

In this case, the software implementation becomes highly protocol dependent. Three possible actions can enable the I<sup>2</sup>C operation to continue:

- Let the I<sup>2</sup>C Host continue to read data by acknowledging the data received. ACK can be sent by software, or automatically in smart mode.
- Transmit a new address packet.
- Terminate the transaction by issuing a stop condition.

**Note:** An ACK or NACK will be automatically transmitted if smart mode is enabled. The Acknowledge Action bit in the Control B register (CTRLB.ACKACT) determines whether ACK or NACK should be sent.

### Transmitting Data Packets

When an address packet with direction Host Write (see [Figure 34-3](#)) was transmitted successfully, INTFLAG.MB will be set. The I<sup>2</sup>C Host will start transmitting data via the I<sup>2</sup>C bus by writing to DATA.DATA, and monitor continuously for packet collisions.

If a collision is detected, the I<sup>2</sup>C Host will lose arbitration and STATUS.ARBLOST will be set. If the transmit was successful, the I<sup>2</sup>C Host will receive an ACK bit from the I<sup>2</sup>C Client, and STATUS.RXNACK will be cleared. INTFLAG.MB will be set in both cases, regardless of arbitration outcome.

It is recommended to read STATUS.ARBLOST and handle the arbitration lost condition in the beginning of the I<sup>2</sup>C Host on Bus interrupt. This can be done as there is no difference between handling address and data packet arbitration.

STATUS.RXNACK must be checked for each data packet transmitted before the next data packet transmission can commence. The I<sup>2</sup>C Host is not allowed to continue transmitting data packets if a NACK is received from the I<sup>2</sup>C Client.

### Receiving Data Packets

When INTFLAG.SB is set, the I<sup>2</sup>C Host will already have received one data packet. The I<sup>2</sup>C Host must respond by sending either an ACK or NACK. Sending a NACK may be unsuccessful when arbitration is lost during the transmission. In this case, a lost arbitration will prevent setting INTFLAG.SB. Instead, INTFLAG.MB will indicate a change in arbitration. Handling of lost arbitration is the same as for data bit transmission.

#### 34.6.2.4.1 Host Clock Generation

The SERCOM peripheral supports several I<sup>2</sup>C bidirectional modes:

- Standard mode (*Sm*) up to 100 kHz
- Fast mode (*Fm*) up to 400 kHz
- Fast mode Plus (*Fm+*) up to 1 MHz
- High-speed mode (*Hs*) up to 3.4 MHz

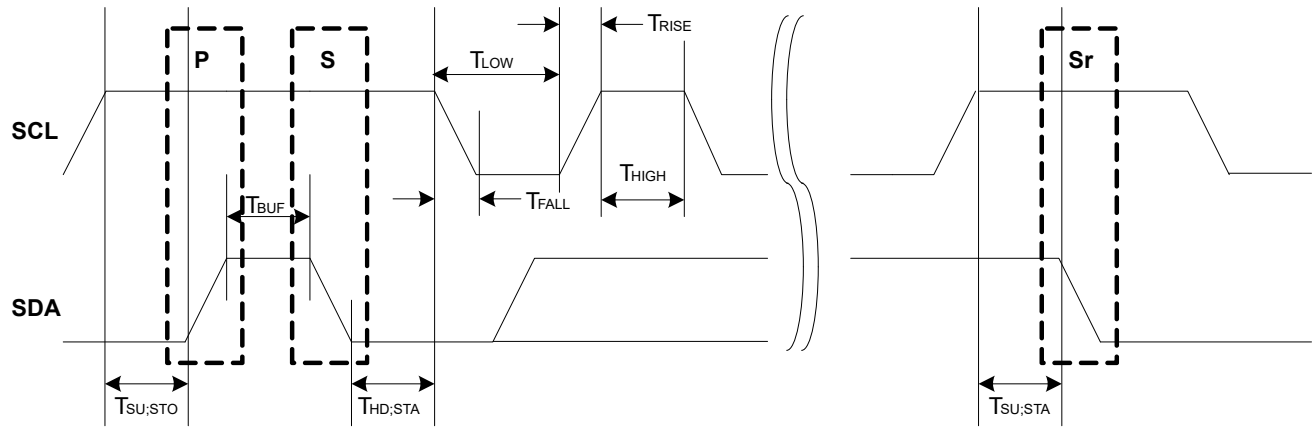
The Host clock configuration for *Sm*, *Fm*, and *Fm+* are described in [Clock Generation \(Standard-Mode, Fast-Mode, and Fast-Mode Plus\)](#). For *Hs*, refer to [Host Clock Generation \(High-Speed Mode\)](#).

#### Clock Generation (Standard-Mode, Fast-Mode, and Fast-Mode Plus)

In I<sup>2</sup>C *Sm*, *Fm*, and *Fm+* mode, the Host clock (SCL) frequency is determined as described in this section:

The low ( $T_{LOW}$ ) and high ( $T_{HIGH}$ ) times are determined by the Baud Rate register (BAUD), while the rise ( $T_{RISE}$ ) and fall ( $T_{FALL}$ ) times are determined by the bus topology. Because of the wired-AND logic of the bus,  $T_{FALL}$  will be considered as part of  $T_{LOW}$ . Likewise,  $T_{RISE}$  will be in a state between  $T_{LOW}$  and  $T_{HIGH}$  until a high state has been detected.

Figure 34-7. SCL Timing



The following parameters are timed using the SCL low time period  $T_{LOW}$ . This comes from the Host Baud Rate Low bit group in the Baud Rate register (BAUD.BAUDLOW). When BAUD.BAUDLOW=0, or the Host Baud Rate bit group in the Baud Rate register (BAUD.BAUD) determines it.

- $T_{LOW}$  – Low period of SCL clock
- $T_{SU;STO}$  – Set-up time for stop condition
- $T_{BUF}$  – Bus free time between stop and start conditions
- $T_{HD;STA}$  – Hold time (repeated) start condition
- $T_{SU;STA}$  – Set-up time for repeated start condition
- $T_{HIGH}$  is timed using the SCL high time count from BAUD.BAUD
- $T_{RISE}$  is determined by the bus impedance; for internal pull-ups.
- $T_{FALL}$  is determined by the open-drain current limit and bus impedance; can typically be regarded as zero.

The SCL frequency is given by:

$$f_{SCL} = \frac{1}{T_{LOW} + T_{HIGH} + T_{RISE}}$$

When BAUD.BAUDLOW is zero, the BAUD.BAUD value is used to time both SCL high and SCL low. In this case the following formula will give the SCL frequency:

$$f_{SCL} = \frac{f_{GCLK}}{10 + 2BAUD + f_{GCLK} \cdot T_{RISE}}$$

When BAUD.BAUDLOW is non-zero, the following formula determines the SCL frequency:

$$f_{SCL} = \frac{f_{GCLK}}{10 + BAUD + BAUDLOW + f_{GCLK} \cdot T_{RISE}}$$

The following formulas can determine the SCL  $T_{LOW}$  and  $T_{HIGH}$  times:

$$T_{LOW} = \frac{BAUDLOW + 5}{f_{GCLK}}$$

$$T_{HIGH} = \frac{BAUD + 5}{f_{GCLK}}$$

**Note:** The I<sup>2</sup>C standard *Fm+* (Fast-mode plus) requires a nominal high to low SCL ratio of 1:2, and BAUD should be set accordingly. At a minimum, BAUD.BAUD and/or BAUD.BAUDLOW must be non-zero.

**Startup Timing** The minimum time between SDA transition and SCL rising edge is 6 APB cycles when the DATA register is written in smart mode. If a greater startup time is required due to long rise times, the time between DATA write and IF clear must be controlled by software.

**Note:** When timing is controlled by user, the Smart Mode cannot be enabled.

#### Host Clock Generation (High-Speed Mode)

For I<sup>2</sup>C *Hs* transfers, there is no SCL synchronization. Instead, the SCL frequency is determined by the GCLK\_SERCOMX\_CORE frequency ( $f_{GCLK}$ ) and the High-Speed Baud setting in the Baud register (BAUD.HSBAUD). When BAUD.HSBAUDLOW=0, the HSBAUD value will determine both SCL high and SCL low. In this case the following formula determines the SCL frequency.

$$f_{SCL} = \frac{f_{GCLK}}{2 + 2 \cdot HSBAUD}$$

When HSBAUDLOW is non-zero, the following formula determines the SCL frequency.

$$f_{SCL} = \frac{f_{GCLK}}{2 + HSBAUD + HSBAUDLOW}$$

**Note:** The I<sup>2</sup>C standard *Hs* (High-speed) requires a nominal high to low SCL ratio of 1:2, and HSBAUD should be set accordingly. At a minimum, BAUD.HSBAUD and/or BAUD.HSBAUDLOW must be non-zero.

#### 34.6.2.4.2 Transmitting Address Packets

The I<sup>2</sup>C Host starts a bus transaction by writing the I<sup>2</sup>C Client address to ADDR.ADDR and the direction bit, as described in 34.6.1. [Principle of Operation](#). If the bus is busy, the I<sup>2</sup>C Host will wait until the bus becomes idle before continuing the operation. When the bus is idle, the I<sup>2</sup>C Host will issue a start condition on the bus. The I<sup>2</sup>C Host will then transmit an address packet using the address written to ADDR.ADDR. After the address packet has been transmitted by the I<sup>2</sup>C Host, one of four cases will arise according to arbitration and transfer direction.

##### Case 1: Arbitration lost or bus error during address packet transmission

If arbitration was lost during transmission of the address packet, the Host on Bus bit in the Interrupt Flag Status and Clear register (INTFLAG.MB) and the Arbitration Lost bit in the Status register (STATUS.ARBLOST) are both set. Serial data output to SDA is disabled, and the SCL is released, which disables clock stretching. In effect the I<sup>2</sup>C Host is no longer allowed to execute any operation on the bus until the bus is idle again. A bus error will behave similarly to the Arbitration Lost condition. In this case, the MB Interrupt flag and Host Bus Error bit in the Status register (STATUS.BUSERR) are both set in addition to STATUS.ARBLOST.

The Host Received Not Acknowledge bit in the Status register (STATUS.RXNACK) will always contain the last successfully received acknowledge or not acknowledge indication.

In this case, software will typically inform the application code of the condition and then clear the Interrupt flag before exiting the interrupt routine. No other flags have to be cleared at this moment, because all flags will be cleared automatically the next time the ADDR.ADDR register is written.

##### Case 2: Address packet transmit complete – No ACK received

If there is no I<sup>2</sup>C Client device responding to the address packet, then the INTFLAG.MB Interrupt flag and STATUS.RXNACK will be set. The clock hold is active at this point, preventing further activity on the bus.

The missing ACK response can indicate that the I<sup>2</sup>C Client is busy with other tasks or sleeping. Therefore, it is not able to respond. In this event, the next step can be either issuing a Stop condition (recommended) or resending the address packet by a repeated Start condition. When using SMBus logic, the Client must ACK the address. If there is no response, it means that the Client is not available on the bus.

##### Case 3: Address packet transmit complete – Write packet, Host on Bus set



If the I<sup>2</sup>C Host receives an acknowledge response from the I<sup>2</sup>C Client, INTFLAG.MB will be set and STATUS.RXNACK will be cleared. The clock hold is active at this point, preventing further activity on the bus.

In this case, the software implementation becomes highly protocol dependent. Three possible actions can enable the I<sup>2</sup>C operation to continue:

- Initiate a data transmit operation by writing the data byte to be transmitted into DATA.DATA.
- Transmit a new address packet by writing ADDR.ADDR. A repeated Start condition will automatically be inserted before the address packet.
- Issue a Stop condition, consequently terminating the transaction.

#### Case 4: Address packet transmit complete – Read packet, Client on Bus set

If the I<sup>2</sup>C Host receives an ACK from the I<sup>2</sup>C Client, the I<sup>2</sup>C Host proceeds to receive the next byte of data from the I<sup>2</sup>C Client. When the first data byte is received, the Client on Bus bit in the Interrupt Flag register (INTFLAG.SB) will be set and STATUS.RXNACK will be cleared. The clock hold is active at this point, preventing further activity on the bus.

In this case, the software implementation becomes highly protocol dependent. Three possible actions can enable the I<sup>2</sup>C operation to continue:

- Let the I<sup>2</sup>C Host continue to read data by acknowledging the data received. ACK can be sent by software, or automatically in Smart mode.
- Transmit a new address packet.
- Terminate the transaction by issuing a Stop condition.

**Note:** An ACK or NACK will be automatically transmitted if Smart mode is enabled. The Acknowledge Action bit in the Control B register (CTRLB.ACKACT) determines whether ACK or NACK should be sent.

### 34.6.2.4.3 Transmitting Data Packets

When an address packet with direction Host Write (see [Figure 34-3](#)) was transmitted successfully, INTFLAG.MB will be set. The I<sup>2</sup>C Host will start transmitting data via the I<sup>2</sup>C bus by writing to DATA.DATA, and monitor continuously for packet collisions.

If a collision is detected, the I<sup>2</sup>C Host will lose arbitration and STATUS.ARBLOST will be set. If the transmit was successful, the I<sup>2</sup>C Host will receive an ACK bit from the I<sup>2</sup>C Client, and STATUS.RXNACK will be cleared. INTFLAG.MB will be set in both cases, regardless of arbitration outcome.

It is recommended to read STATUS.ARBLOST and handle the arbitration lost condition in the beginning of the I<sup>2</sup>C Host on Bus interrupt. This can be done as there is no difference between handling address and data packet arbitration.

STATUS.RXNACK must be checked for each data packet transmitted before the next data packet transmission can commence. The I<sup>2</sup>C Host is not allowed to continue transmitting data packets if a NACK is received from the I<sup>2</sup>C Client.

### 34.6.2.4.4 Receiving Data Packets (SCLSM=0)

When INTFLAG.SB is set, the I<sup>2</sup>C Host will already have received one data packet. The I<sup>2</sup>C Host must respond by sending either an ACK or NACK. Sending a NACK may be unsuccessful when arbitration is lost during the transmission. In this case, a lost arbitration will prevent setting INTFLAG.SB. Instead, INTFLAG.MB will indicate a change in arbitration. Handling of lost arbitration is the same as for data bit transmission.

### 34.6.2.4.5 Receiving Data Packets (SCLSM=1)

When INTFLAG.SB is set, the I<sup>2</sup>C Host will already have received one data packet and transmitted an ACK or NACK, depending on CTRLB.ACKACT. At this point, CTRLB.ACKACT must be set to the correct value for the next ACK bit, and the transaction can continue by reading DATA and issuing a command if not in the Smart mode.

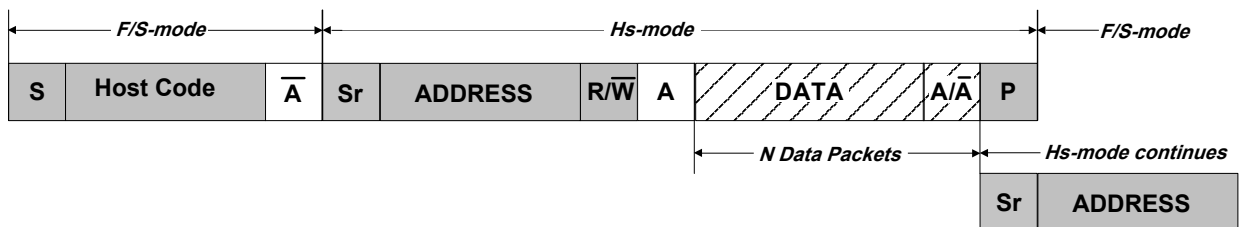
### 34.6.2.4.6 High-Speed Mode

High-speed transfers are a multi-step process, see [High Speed Transfer](#).

First, a Host code (0b00001nnn, where 'nnn' is a unique Host code) is transmitted in Full-speed mode, followed by a NACK since no Client should acknowledge. Arbitration is performed only during the Full-speed Host Code phase. The Host code is transmitted by writing the Host code to the Address register (ADDR.ADDR) and writing the High-speed bit (ADDR.HS) to '0'.

After the Host code and NACK have been transmitted, the Host write interrupt will be asserted. In the meanwhile, the Client address can be written to the ADDR.ADDR register together with ADDR.HS=1. Now in High-speed mode, the Host will generate a repeated start, followed by the Client address with RW-direction. The bus will remain in High-speed mode until a stop is generated. If a repeated start is desired, the ADDR.HS bit must again be written to '1', along with the new address ADDR.ADDR to be transmitted.

Figure 34-8. High Speed Transfer



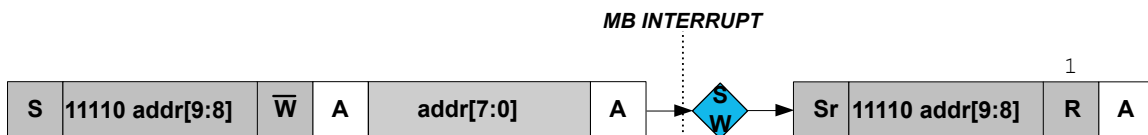
Transmitting in High-speed mode requires the I<sup>2</sup>C Host to be configured in High-speed mode (CTRLA.SPEED=0x2) and the SCL Clock Stretch mode (CTRLA.SCLSM) bit set to '1'.

### 34.6.2.4.7 10-Bit Addressing

When 10-bit addressing is enabled by the Ten Bit Addressing Enable bit in the Address register (ADDR.TENBITEN=1) and the Address bit field ADDR.ADDR is written, the two address bytes will be transmitted, see [10-bit Address Transmission for a Read Transaction](#). The addressed Client acknowledges the two address bytes, and the transaction continues. Regardless of whether the transaction is a read or write, the Host must start by sending the 10-bit address with the direction bit (ADDR.ADDR[0]) being zero.

If the Host receives a NACK after the first byte, the Write Interrupt flag will be raised and the STATUS.RXNACK bit will be set. If the first byte is acknowledged by one or more Clients, then the Host will proceed to transmit the second address byte and the Host will first see the Write Interrupt flag after the second byte is transmitted. If the transaction direction is read-from-Client, the 10-bit address transmission must be followed by a repeated start and the first 7 bits of the address with the read/write bit equal to '1'.

Figure 34-9. 10-bit Address Transmission for a Read Transaction



This implies the following procedure for a 10-bit read operation:

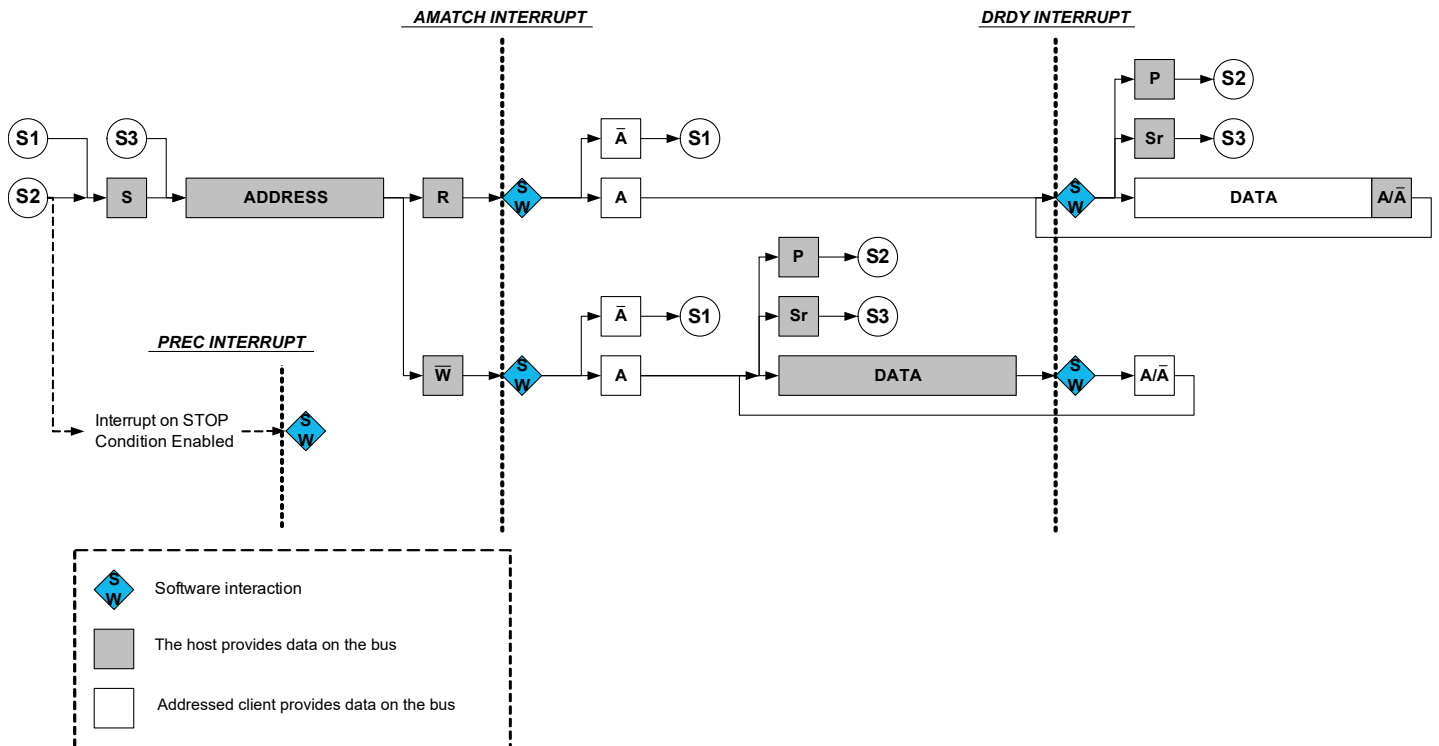
1. Write the 10-bit address to ADDR.ADDR[10:1]. ADDR.TENBITEN must be '1', the direction bit (ADDR.ADDR[0]) must be '0' (can be written simultaneously with ADDR).
2. Once the Host on Bus interrupt is asserted, Write ADDR[7:0] register to '11110 address[9:8] 1'. ADDR.TENBITEN must be cleared (can be written simultaneously with ADDR).
3. Proceed to transmit data.

### 34.6.2.5 I<sup>2</sup>C Client Operation

The I<sup>2</sup>C Client is byte-oriented and interrupt-based. The number of interrupts generated is kept at a minimum by automatic handling of most events. The software driver complexity and code size are reduced by auto-triggering of operations, and a special smart mode, which can be enabled by the Smart Mode Enable bit in the Control B register (CTRLB.SMEN).

This diagram is used as reference for the description of the I<sup>2</sup>C Client operation throughout the document.

**Figure 34-10.** I<sup>2</sup>C Client Behavioral Diagram



#### Receiving Address Packets

When a start condition is detected, the successive address packet will be received and checked by the address match logic. If the received address is not a match, the packet will be rejected, and the I<sup>2</sup>C Client will wait for a new start condition. If the received address is a match, the Address Match bit in the Interrupt Flag register (INTFLAG.AMATCH) will be set.

SCL will be stretched until the I<sup>2</sup>C Client clears INTFLAG.AMATCH. As the I<sup>2</sup>C Client holds the clock by forcing SCL low, the software has unlimited time to respond.

The direction of a transaction is determined by reading the Read / Write Direction bit in the Status register (STATUS.DIR). This bit will be updated only when a valid address packet is received.

If the Transmit Collision bit in the Status register (STATUS.COLL) is set, this indicates that the last packet addressed to the I<sup>2</sup>C Client had a packet collision. A collision causes the SDA and SCL lines to be released without any notification to software. Therefore, the next AMATCH interrupt is the first indication of the previous packet's collision. Collisions are intended to follow the SMBus Address Resolution Protocol (ARP).

After the address packet has been received from the I<sup>2</sup>C Host, one of two cases will arise based on transfer direction.

#### Case 1: Address packet accepted – Read flag set

The STATUS.DIR bit is '1', indicating an I<sup>2</sup>C Host read operation. The SCL line is forced low, stretching the bus clock. If an ACK is sent, I<sup>2</sup>C Client hardware will set the Data Ready bit in the Interrupt Flag register (INTFLAG.DRDY), indicating data are needed for transmit. If a NACK is sent, the I<sup>2</sup>C Client will wait for a new start condition and address match.

Typically, software will immediately acknowledge the address packet by sending an ACK/NACK bit. The I<sup>2</sup>C Client Command bit field in the Control B register (CTRLB.CMD) can be written to '0x3' for both read and write operations as the command execution is dependent on the STATUS.DIR bit. Writing '1' to INTFLAG.AMATCH will also cause an ACK/NACK to be sent corresponding to the CTRLB.ACKACT bit.

### Case 2: Address packet accepted – Write flag set

The STATUS.DIR bit is cleared, indicating an I<sup>2</sup>C Host write operation. The SCL line is forced low, stretching the bus clock. If an ACK is sent, the I<sup>2</sup>C Client will wait for data to be received. Data, repeated start or stop can be received.

If a NACK is sent, the I<sup>2</sup>C Client will wait for a new start condition and address match. Typically, software will immediately acknowledge the address packet by sending an ACK/NACK. The I<sup>2</sup>C Client command CTRLB.CMD = 3 can be used for both read and write operation as the command execution is dependent on STATUS.DIR.

Writing '1' to INTFLAG.AMATCH will also cause an ACK/NACK to be sent corresponding to the CTRLB.ACKACT bit.

### Receiving and Transmitting Data Packets

After the I<sup>2</sup>C Client has received an address packet, it will respond according to the direction either by waiting for the data packet to be received or by starting to send a data packet by writing to DATA.DATA. When a data packet is received or sent, INTFLAG.DRDY will be set. After receiving data, the I<sup>2</sup>C Client will send an acknowledge according to CTRLB.ACKACT.

#### Case 1: Data received

INTFLAG.DRDY is set, and SCL is held low, pending for SW interaction.

#### Case 2: Data sent

When a byte transmission is successfully completed, the INTFLAG.DRDY interrupt flag is set. If NACK is received, indicated by STATUS.RXNACK=1, the I<sup>2</sup>C Client must expect a stop or a repeated start to be received. The I<sup>2</sup>C Client must release the data line to allow the I<sup>2</sup>C Host to generate a stop or repeated start. Upon detecting a stop condition, the Stop Received bit in the Interrupt Flag register (INTFLAG.PREC) will be set and the I<sup>2</sup>C Client will return to IDLE state.

#### 34.6.2.5.1 Receiving Address Packets (SCLSM=0)

When CTRLA.SCLSM=0, the I<sup>2</sup>C Client stretches the SCL line according to [Figure 34-10](#). When the I<sup>2</sup>C Client is properly configured, it will wait for a Start condition.

When a Start condition is detected, the successive address packet will be received and checked by the address match logic. If the received address is not a match, the packet will be rejected, and the I<sup>2</sup>C Client will wait for a new Start condition. If the received address is a match, the Address Match bit in the Interrupt Flag register (INTFLAG.AMATCH) will be set.

SCL will be stretched until the I<sup>2</sup>C Client clears INTFLAG.AMATCH. As the I<sup>2</sup>C Client holds the clock by forcing SCL low, the software has unlimited time to respond.

The direction of a transaction is determined by reading the Read/Write Direction bit in the Status register (STATUS.DIR). This bit will be updated only when a valid address packet is received.

If the Transmit Collision bit in the Status register (STATUS.COLL) is set, this indicates that the last packet addressed to the I<sup>2</sup>C Client had a packet collision. A collision causes the SDA and SCL lines to be released without any notification to software. Therefore, the next AMATCH interrupt is the first

indication of the previous packet's collision. Collisions are intended to follow the SMBus Address Resolution Protocol (ARP).

After the address packet has been received from the I<sup>2</sup>C Host, one of two cases will arise based on transfer direction.

#### Case 1: Address packet accepted – Read flag set

The STATUS.DIR bit is '1', indicating an I<sup>2</sup>C Host read operation. The SCL line is forced low, stretching the bus clock. If an ACK is sent, I<sup>2</sup>C Client hardware will set the Data Ready bit in the Interrupt Flag register (INTFLAG.DRDY), indicating data are needed for transmit. If a NACK is sent, the I<sup>2</sup>C Client will wait for a new Start condition and address match.

Typically, software will immediately acknowledge the address packet by sending an ACK/NACK bit. The I<sup>2</sup>C Client Command bit field in the Control B register (CTRLB.CMD) can be written to '0x3' for both read and write operations as the command execution is dependent on the STATUS.DIR bit. Writing '1' to INTFLAG.AMATCH will also cause an ACK/NACK to be sent corresponding to the CTRLB.ACKACT bit.

#### Case 2: Address packet accepted – Write flag set

The STATUS.DIR bit is cleared, indicating an I<sup>2</sup>C Host write operation. The SCL line is forced low, stretching the bus clock. If an ACK is sent, the I<sup>2</sup>C Client will wait for data to be received. Data, repeated start or stop can be received.

If a NACK is sent, the I<sup>2</sup>C Client will wait for a new Start condition and address match. Typically, software will immediately acknowledge the address packet by sending an ACK/NACK. The I<sup>2</sup>C Client command CTRLB.CMD = 3 can be used for both read and write operation as the command execution is dependent on STATUS.DIR.

Writing '1' to INTFLAG.AMATCH will also cause an ACK/NACK to be sent corresponding to the CTRLB.ACKACT bit.

### 34.6.2.5.2 Receiving Address Packets (SCLSM=1)

When SCLSM=1, the I<sup>2</sup>C Client will stretch the SCL line only after an ACK, see [Figure 34-10](#). When the I<sup>2</sup>C Client is properly configured, it will wait for a Start condition to be detected.

When a Start condition is detected, the successive address packet will be received and checked by the address match logic.

If the received address is not a match, the packet will be rejected and the I<sup>2</sup>C Client will wait for a new Start condition.

If the address matches, the acknowledge action as configured by the Acknowledge Action bit Control B register (CTRLB.ACKACT) will be sent and the Address Match bit in the Interrupt Flag register (INTFLAG.AMATCH) is set. SCL will be stretched until the I<sup>2</sup>C Client clears INTFLAG.AMATCH. As the I<sup>2</sup>C Client holds the clock by forcing SCL low, the software is given unlimited time to respond to the address.

The direction of a transaction is determined by reading the Read/Write Direction bit in the Status register (STATUS.DIR). This bit will be updated only when a valid address packet is received.

If the Transmit Collision bit in the Status register (STATUS.COLL) is set, the last packet addressed to the I<sup>2</sup>C Client had a packet collision. A collision causes the SDA and SCL lines to be released without any notification to software. The next AMATCH interrupt is, therefore, the first indication of the previous packet's collision. Collisions are intended to follow the SMBus Address Resolution Protocol (ARP).

After the address packet has been received from the I<sup>2</sup>C Host, INTFLAG.AMATCH be set to '1' to clear it.

### 34.6.2.5.3 Receiving and Transmitting Data Packets

After the I<sup>2</sup>C Client has received an address packet, it will respond according to the direction either by waiting for the data packet to be received or by starting to send a data packet by writing to DATA.DATA. When a data packet is received or sent, INTFLAG.DRDY will be set. After receiving data, the I<sup>2</sup>C Client will send an acknowledge according to CTRLB.ACKACT.

#### Case 1: Data received

INTFLAG.DRDY is set, and SCL is held low, pending for SW interaction.

#### Case 2: Data sent

When a byte transmission is successfully completed, the INTFLAG.DRDY Interrupt flag is set. If NACK is received, indicated by STATUS.RXNACK=1, the I<sup>2</sup>C Client must expect a stop or a repeated start to be received. The I<sup>2</sup>C Client must release the data line to allow the I<sup>2</sup>C Host to generate a stop or repeated start. Upon detecting a Stop condition, the Stop Received bit in the Interrupt Flag register (INTFLAG.PREC) will be set and the I<sup>2</sup>C Client will return to IDLE state.

### 34.6.2.5.4 High-Speed Mode

When the I<sup>2</sup>C Client is configured in High-speed mode (*Hs*, CTRLA.SPEED=0x2) and CTRLA.SCLSM=1, switching between Full-speed and High-speed modes is automatic. When the Client recognizes a START followed by a Host code transmission and a NACK, it automatically switches to High-speed mode and sets the High-speed status bit (STATUS.HS). The Client will then remain in High-speed mode until a STOP is received.

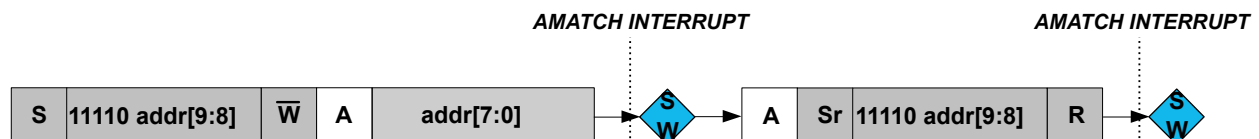
### 34.6.2.5.5 10-Bit Addressing

When 10-bit addressing is enabled (ADDR.TENBITEN=1), the two address bytes following a START will be checked against the 10-bit Client address recognition. The first byte of the address will always be acknowledged, and the second byte will raise the address Interrupt flag, see [10-bit Addressing](#).

If the transaction is a write, then the 10-bit address will be followed by *N* data bytes.

If the operation is a read, the 10-bit address will be followed by a repeated START and reception of '11110 ADDR[9:8] 1', and the second address interrupt will be received with the DIR bit set. The Client matches on the second address as it was addressed by the previous 10-bit address.

Figure 34-11. 10-bit Addressing



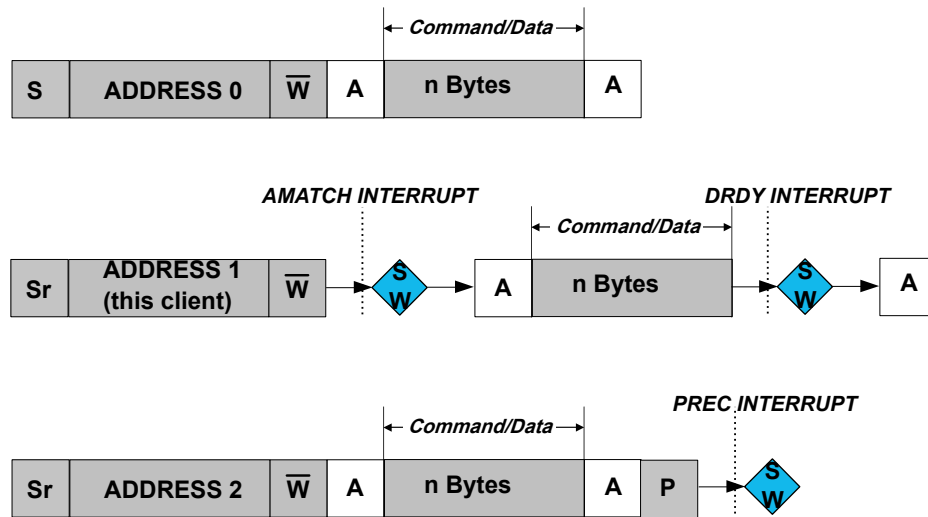
### 34.6.2.5.6 PMBus Group Command

When the PMBus Group Command bit in the CTRLB register is set (CTRLB.GCMD=1) and 7-bit addressing is used, INTFLAG.PREC will be set if the Client has been addressed since the last STOP condition. When CTRLB.GCMD=0, a STOP condition without address match will not be set INTFLAG.PREC.

The group command protocol is used to send commands to more than one device. The commands are sent in one continuous transmission with a single STOP condition at the end. When the STOP condition is detected by the Clients addressed during the group command, they all begin executing the command they received.

[PMBus Group Command Example](#) shows an example where this Client, bearing ADDRESS 1, is addressed after a repeated START condition. There can be multiple Clients addressed before and after this Client. Eventually, at the end of the group command, a single STOP is generated by the Host. At this point a STOP interrupt is asserted.

Figure 34-12. PMBus Group Command Example



### 34.6.3 Additional Features

#### 34.6.3.1 SMBus

The I<sup>2</sup>C includes three hardware SCL low time-outs, which allow a time-out to occur for SMBus SCL low time-out, Host extend time-out, and Client extend time-out. This allows for SMBus functionality. These time-outs are driven by the GCLK\_SERCOM\_SLOW clock. The GCLK\_SERCOM\_SLOW clock is used to accurately time the time-out and must be configured to use a 32.768 kHz oscillator. The I<sup>2</sup>C interface also allows for a SMBus compatible SDA hold time.

- $T_{\text{TIMEOUT}}$ : SCL low time of 25..35ms – Measured for a single SCL low period. It is enabled by CTRLA.LOWTOUTEN.
- $T_{\text{LOW:SEXT}}$ : Cumulative clock low extend time of 25 ms – Measured as the cumulative SCL low extend time by a Client device in a single message from the initial START to the STOP. It is enabled by CTRLA.SEXTTOEN.
- $T_{\text{LOW:MEXT}}$ : Cumulative clock low extend time of 10 ms – Measured as the cumulative SCL low extend time by the Host device within a single byte from START-to-ACK, ACK-to-ACK, or ACK-to-STOP. It is enabled by CTRLA.MEXTTOEN.

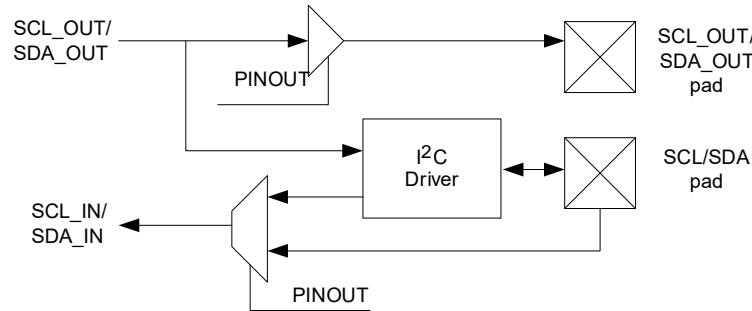
#### 34.6.3.2 Smart Mode

The I<sup>2</sup>C interface has a Smart mode that simplifies application code and minimizes the user interaction needed to adhere to the I<sup>2</sup>C protocol. The Smart mode accomplishes this by automatically issuing an ACK or NACK (based on the content of CTRLB.ACKACT) as soon as DATA.DATA is read.

#### 34.6.3.3 4-Wire Mode

Writing a '1' to the Pin Usage bit in the Control A register (CTRLA.PINOUT) will enable 4-Wire mode operation. In this mode, the internal I<sup>2</sup>C tri-state drivers are bypassed, and an external I<sup>2</sup>C compliant tri-state driver is needed when connecting to an I<sup>2</sup>C bus.

**Figure 34-13.** I<sup>2</sup>C Pad Interface



### 34.6.3.4 Quick Command

Setting the Quick Command Enable bit in the Control B register (CTRLB.QCEN) enables quick command. When quick command is enabled, the corresponding Interrupt flag (INTFLAG.SB or INTFLAG.MB) is set immediately after the client acknowledges the address. At this point, the software can either issue a Stop command or a repeated start by writing CTRLB.CMD or ADDR.ADDR.



**Important:** The use of the Quick Command mode (CTRLB.QCEN = 1) is only allowed if SCL Stretch Mode is CTRLA.SCLSM=0 which makes the Quick Command feature not available in High-Speed mode.

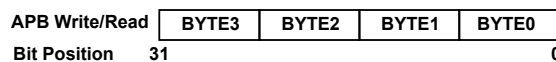
### 34.6.3.5 32-bit Extension

For better system bus utilization, 32-bit data receive and transmit can be enabled by writing to the Data 32-bit bit field in the Control C register (CTRLC.DATA32B=1). When enabled, write and read transaction to/from the DATA register are 32 bit in size.

If frames are not multiples of 4 Bytes, the Length Counter (LENGTH.LEN) and Length Enable (LENGTH.LENEN) must be configured before data transfer begins. LENGTH.LEN must be enabled only when CTRLC.DATA32B is enabled.

The figure below shows the order of transmit and receive when using 32-bit mode. Bytes are transmitted or received and stored in order from 0 to 3.

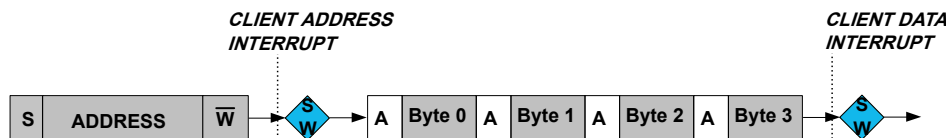
**Figure 34-14.** 32-bit Extension Byte Ordering



### 32-bit Extension Client Operation

The figure below shows a transaction with 32-bit Extension enabled (CTRLC.DATA32B=1). In Client operation, the Address Match interrupt in the Interrupt Flag Status and Clear register (INTFLAG.AMATCH) is set after the address is received and available in the DATA register. The Data Ready interrupt (INTFLAG.DRDY) will then be raised for every 4 Bytes transferred.

**Figure 34-15.** 32-bit Extension Client Operation



The LENGTH register can be written before the frame begins, or when the AMATCH interrupt is set. If the frame size is not LENGTH.LEN Bytes, the Length Error status bit (STATUS.LENERR) is raised. If



LENGTH.LEN is not a multiple of 4 Bytes, the final INTFLAG.DRDY interrupt is raised when the last Byte is received for Host reads. For Host writes, the last data byte will be automatically NACKed. On address recognition, the internal length counter is reset in preparation for the incoming frame.

High Speed transactions start with a Full Speed Host Code. When a Host Code is detected, no data is received and the next expected operation is a repeated start. For this reason, the length is not counted after a Host Code is received. In this case, no Length Error (STATUS.LENERR) is registered, regardless of the LENGTH.LENEN setting.

When SCL clock stretch mode is selected (CTRLA.SCLSM=1) and the transaction is a Host write, the selected Acknowledge Action (CTRLB.ACKACT) will only be used to ACK/NACK each 4th byte. All other bytes are ACKed. This allows the user to write CTRLB.ACKACT=1 in the final interrupt, so that the last byte in a 32-bit word will be NACKed.

Writing to the LENGTH register while a frame is in progress will produce unpredictable results. If LENGTH.LENEN is not set and a frame is not a multiple of 4 Bytes, the remainder will be lost.

### 32-bit Extension Host Operation

When using the I<sup>2</sup>C configured as Host, the Address register must be written with the desired address (ADDR.ADDR), and optionally, the transaction Length and transaction Length Enable bits (ADDR.LEN and ADDR.LENEN) can be written. When ADDR.LENEN is written to '1' along with ADDR.ADDR, ADDR.LEN determines the number of data bytes in the transaction from 0 to 255. Then, the ADDR.LEN bytes are transferred, followed by an automatically generated NACK (for Host reads) and a STOP.

The INTFLAG.SB or INTFLAG.MB are raised for every 4 Bytes transferred. If the transaction is a Host read and ADDR.LEN is not a multiple of 4 Bytes, the final INTFLAG.SB is set when the last byte is received.

When SCL clock stretch mode is enabled (CTRLA.SCLSM=1) and the transaction is a Host read, the selected Acknowledge Action (CTRLB.ACKACT) will only be used to ACK/NACK each 4th Byte. All other bytes are ACKed. This allows the user to set CTRLB.ACKACT=1 in the final interrupt, so that the last byte in a 32-bit word will be NACKed.

If a NACK is received by the Client for a Host write transaction before ADDR.LEN bytes, a STOP will be automatically generated, and the length error (STATUS.LENERR) is raised along with the INTFLAG.ERROR interrupt.

## 34.6.4 DMA, Interrupts and Events

Each interrupt source has its own Interrupt flag. The Interrupt flag in the Interrupt Flag Status and Clear register (INTFLAG) will be set when the Interrupt condition is met. Each interrupt can be individually enabled by writing '1' to the corresponding bit in the Interrupt Enable Set register (INTENSET), and disabled by writing '1' to the corresponding bit in the Interrupt Enable Clear register (INTENCLR). An interrupt request is generated when the Interrupt flag is set and the corresponding interrupt is enabled. The interrupt request is active until the Interrupt flag is cleared, the interrupt is disabled or the I<sup>2</sup>C is reset. See the [INTFLAG \(Client\)](#) or [INTFLAG \(Host\)](#) register for details on how to clear Interrupt flags.

**Table 34-2.** Module Request for SERCOM I<sup>2</sup>C Client

Condition	Request		
	DMA	Interrupt	Event
Data needed for transmit (TX) (Client Transmit mode)	Yes (request cleared when data is written)	-	N/A
Data received (RX) (Client Receive mode)	Yes (request cleared when data is read)	-	
Data Ready (DRDY)	-	Yes	
Address Match (AMATCH)	-	Yes	
Stop received (PREC)	-	Yes	
Error (ERROR)	-	Yes	

**Table 34-3.** Module Request for SERCOM I<sup>2</sup>C Host

Condition	Request		
	DMA	Interrupt	Event
Data needed for transmit (TX) (Host Transmit mode)	Yes (request cleared when data is written)	-	N/A
Data needed for transmit (RX) (Host Transmit mode)	Yes (request cleared when data is read)	-	
Host on Bus (MB)	-	Yes	
Stop received (SB)	-	Yes	
Error (ERROR)	-	Yes	

### 34.6.4.1 DMA Operation

Smart mode must be enabled for DMA operation in the Control B register by writing CTRLB.SMEN=1.

#### 34.6.4.1.1 Client DMA

When using the I<sup>2</sup>C Client with DMA, an address match will cause the address Interrupt flag (INTFLAG.ADDRMATCH) to be raised. After the interrupt has been serviced, data transfer will be performed through DMA.

The I<sup>2</sup>C Client generates the following requests:

- Write data received (RX): The request is set when Host write data is received. The request is cleared when DATA is read.
- Read data needed for transmit (TX): The request is set when data is needed for a Host read operation. The request is cleared when DATA is written.

#### 34.6.4.1.2 Host DMA

When using the I<sup>2</sup>C Host with DMA, the ADDR register must be written with the desired address (ADDR.ADDR), transaction length (ADDR.LEN), and transaction length enable (ADDR.LENEN). When ADDR.LENEN is written to 1 along with ADDR.ADDR, ADDR.LEN determines the number of data bytes in the transaction from 0 to 255. DMA is then used to transfer ADDR.LEN bytes followed by an automatically generated NACK (for Host reads) and a STOP.

If a NACK is received by the Client for a Host write transaction before ADDR.LEN bytes, a STOP will be automatically generated and the length error (STATUS.LENERR) will be raised along with the INTFLAG.ERROR interrupt.

The I<sup>2</sup>C Host generates the following requests:

- Read data received (RX): The request is set when Host read data is received. The request is cleared when DATA is read.
- Write data needed for transmit (TX): The request is set when data is needed for a Host write operation. The request is cleared when DATA is written.

#### 34.6.4.2 Interrupts

The I<sup>2</sup>C Client has the following interrupt sources. These are asynchronous interrupts. They can wake-up the device from any Sleep mode:

- Error (ERROR)
- Data Ready (DRDY)
- Address Match (AMATCH)
- Stop Received (PREC)

The I<sup>2</sup>C Host has the following interrupt sources. These are asynchronous interrupts. They can wake-up the device from any Sleep mode:

- Error (ERROR)
- Client on Bus (SB)
- Host on Bus (MB)

Each interrupt source has its own Interrupt flag. The Interrupt flag in the Interrupt Flag Status and Clear register (INTFLAG) will be set when the Interrupt condition is met. Each interrupt can be individually enabled by writing '1' to the corresponding bit in the Interrupt Enable Set register (INTENSET), and disabled by writing '1' to the corresponding bit in the Interrupt Enable Clear register (INTENCLR).

The status of enabled interrupts can be read from either INTENSET or INTENCLR. An interrupt request is generated when the Interrupt flag is set and the corresponding interrupt is enabled. The interrupt request active until the Interrupt flag is cleared, the interrupt is disabled or the I<sup>2</sup>C is reset. See the INTFLAG register for details on how to clear Interrupt flags.

The value of INTFLAG indicates which interrupt is executed. Note that interrupts must be globally enabled for interrupt requests. Refer to [Nested Vector Interrupt Controller](#) for details.

#### 34.6.5 Sleep Mode Operation

##### I<sup>2</sup>C Host Operation

The generic clock (GCLK\_SERCOMx\_CORE) will continue to run in idle sleep mode. If the Run In Standby bit in the Control A register (CTRLA.RUNSTDBY) is '1', the GLK\_SERCOMx\_CORE will also run in Standby Sleep mode. Any interrupt can wake-up the device.

If CTRLA.RUNSTDBY=0, the GLK\_SERCOMx\_CORE will be disabled after any ongoing transaction is finished. Any interrupt can wake-up the device.

##### I<sup>2</sup>C Client Operation

Writing CTRLA.RUNSTDBY=1 will allow the Address Match interrupt to wake-up the device.

When CTRLA.RUNSTDBY=0, all receptions will be dropped.

#### 34.6.6 Synchronization

Due to asynchronicity between the main clock domain and the peripheral clock domains, some registers need to be synchronized when written or read.

The following bits are synchronized when written:

- Software Reset bit in the CTRLA register (CTRLA.SWRST)
- Enable bit in the CTRLA register (CTRLA.ENABLE)

- Command bits in CTRLB register (CTRLB.CMD)
- Write to Bus State bits in the Status register (STATUS.BUSSTATE)
- Address bits in the Address register (ADDR.ADDR) when in Host operation.

The following registers are synchronized when written:

- Data (DATA) when in Host operation
- Length (LENGTH) when in Client operation

Required write synchronization is denoted by the "Write-Synchronized" property in the register description.

### 34.7 Register Summary - I2C Client

Offset	Name	Bit Pos.	7	6	5	4	3	2	1	0	
0x00	CTRLA	7:0	RUNSTDBY				MODE[2:0]		ENABLE	SWRST	
		15:8									
		23:16	SEXTTOEN		SDAHOLD[1:0]					PINOUT	
		31:24		LOWTOUTEN			SCLSM		SPEED[1:0]		
0x04	CTRLB	7:0							GCMD	SMEN	
		15:8	AMODE[1:0]						ACKACT	CMD[1:0]	
		23:16									
31:24											
0x08	CTRLC	7:0					SDASETUP[3:0]				
		15:8									
		23:16									
		31:24								DATA32B	
0x0C ... 0x13	Reserved										
0x14	INTENCLR	7:0	ERROR					DRDY	AMATCH	PREC	
0x15	Reserved										
0x16	INTENSET	7:0	ERROR					DRDY	AMATCH	PREC	
0x17	Reserved										
0x18	INTFLAG	7:0	ERROR					DRDY	AMATCH	PREC	
0x19	Reserved										
0x1A	STATUS	7:0	CLKHOLD	LOWTOUT		SR	DIR	RXNACK	COLL	BUSERR	
		15:8					LENERR	HS	SEXTTOUT		
0x1C	SYNCBUSY	7:0				LENGTH			ENABLE	SWRST	
		15:8									
		23:16									
		31:24									
0x20 ... 0x21	Reserved										
0x22	LENGTH	7:0	LEN[7:0]								
		15:8								LENEN	
0x24	ADDR	7:0	ADDR[6:0]							GENCEN	
		15:8	TENBITEN					ADDR[9:7]			
		23:16	ADDRMASK[6:0]								
		31:24	ADDRMASK[9:7]								
0x28	DATA	7:0	DATA[7:0]								
		15:8	DATA[15:8]								
		23:16	DATA[23:16]								
		31:24	DATA[31:24]								

### 34.7.1 Control A

**Name:** CTRLA  
**Offset:** 0x00  
**Reset:** 0x00000000  
**Property:** PAC Write-Protection, Enable-Protected Bits, Write-Synchronized Bits

Bit	31	30	29	28	27	26	25	24
		LOWTOUTEN			SCLSM		SPEED[1:0]	
Access		R/W			R/W		R/W	R/W
Reset		0			0		0	0
Bit	23	22	21	20	19	18	17	16
	SEXTTOEN		SDAHOLD[1:0]					PINOUT
Access	R/W		R/W	R/W				R/W
Reset	0		0	0				0
Bit	15	14	13	12	11	10	9	8
Access								
Reset								
Bit	7	6	5	4	3	2	1	0
	RUNSTDBY			MODE[2:0]			ENABLE	SWRST
Access	R/W			R/W	R/W	R/W	R/W	R/W
Reset	0			0	0	0	0	0

#### Bit 30 – LOWTOUTEN SCL Low Time-Out Enable

This bit enables the SCL low time-out. If SCL is held low for 25ms-35ms, the Client will release its clock hold, if enabled, and reset the internal state machine. Any interrupt flags set at the time of time-out will remain set.

This bit is not synchronized.

Value	Description
0	Time-out disabled.
1	Time-out enabled.

#### Bit 27 – SCLSM SCL Clock Stretch Mode

This bit controls when SCL will be stretched for software interaction.

This bit is not synchronized.

Value	Description
0	SCL stretch according to <a href="#">Figure 34-10</a>
1	SCL stretch only after ACK bit according to <a href="#">Figure 34-10</a>

#### Bits 25:24 – SPEED[1:0] Transfer Speed

These bits define bus speed.

These bits are not synchronized.

Value	Name	Description
0x0	STANDARD_AND_FAST_MODE	Standard-mode (Sm) up to 100 kHz and Fast-mode (Fm) up to 400 kHz
0x1	FASTPLUS_MODE	Fast-mode Plus (Fm+) up to 1 MHz
0x2	HIGH_SPEED_MODE	High-speed mode (Hs-mode) up to 3.4 MHz
0x3	-	Reserved

**Bit 23 – SEXTTOEN** Client SCL Low Extend Time-Out

This bit enables the Client SCL low extend time-out. If SCL is cumulatively held low for greater than 25ms from the initial START to a STOP, the Client will release its clock hold if enabled and reset the internal state machine. Any interrupt flags set at the time of time-out will remain set. If the address was recognized, PREC will be set when a STOP is received.

This bit is not synchronized.

Value	Description
0	Time-out disabled
1	Time-out enabled

**Bits 21:20 – SDAHOLD[1:0]** SDA Hold Time

These bits define the SDA hold time with respect to the negative edge of SCL.

These bits are not synchronized.

Value	Name	Description
0x0	DISABLE	Disabled
0x1	75NS	50-100ns hold time
0x2	450NS	300-600ns hold time
0x3	600NS	400-800ns hold time

**Bit 16 – PINOUT** Pin Usage

This bit sets the pin usage to either two- or four-wire operation:

This bit is not synchronized.

Value	Description
0	4-wire operation disabled
1	4-wire operation enabled

**Bit 7 – RUNSTDBY** Run in Standby

This bit defines the functionality in standby sleep mode.

This bit is not synchronized.

Value	Description
0	Disabled – All reception is dropped.
1	Wake on address match, if enabled.

**Bits 4:2 – MODE[2:0]** Operating Mode

These bits must be written to 0x04 to select the I<sup>2</sup>C Client serial communication interface of the SERCOM.

These bits are not synchronized.

**Bit 1 – ENABLE** Enable

Due to synchronization, there is delay from writing CTRLA.ENABLE until the peripheral is enabled/disabled. The value written to CTRLA.ENABLE will read back immediately and the Enable Synchronization Busy bit in the Synchronization Busy register (SYNCBUSY.ENABLE) will be set. SYNCBUSY.ENABLE will be cleared when the operation is complete.

This bit is not enable-protected.

Value	Description
0	The peripheral is disabled or being disabled.
1	The peripheral is enabled.

**Bit 0 – SWRST** Software Reset

Writing '0' to this bit has no effect.

Writing '1' to this bit resets all registers in the SERCOM, except DBGCTRL, to their initial state, and the SERCOM will be disabled.

**Note:** Software Reset (CTRLA.SWRST = 1) is not functional when the SERCOM is not enabled (CTRLA.ENABLE = 0).

Writing '1' to CTRLA.SWRST will always take precedence, meaning that all other writes in the same write-operation will be discarded. Any register write access during the ongoing reset will result in an APB error. Reading any register will return the reset value of the register. Due to synchronization, there is a delay from writing CTRLA.SWRST until the reset is complete. CTRLA.SWRST and SYNCBUSY.SWRST will both be cleared when the reset is complete.

**Notes:**

1. When the CTRLA.SWRST is written, the user must poll the SYNCBUSY.SWRST bit to know when the reset operation is complete.
2. During a SWRST, access to registers or bits without the SWRST are disallowed until the SYNCBUSY.SWRST is cleared by hardware.
3. This bit is not Enable-Protected.

Value	Description
0	There is no reset operation ongoing.
1	The reset operation is ongoing.



### 34.7.2 Control B

**Name:** CTRLB  
**Offset:** 0x04  
**Reset:** 0x00000000  
**Property:** PAC Write-Protection, Enable-Protected

Bit	31	30	29	28	27	26	25	24
Access								
Reset								
Bit	23	22	21	20	19	18	17	16
Access						ACKACT	CMD[1:0]	
Reset						R/W	W	W
						0	0	0
Bit	15	14	13	12	11	10	9	8
Access	AMODE[1:0]						GCMD	SMEN
Reset	R/W	R/W					R/W	R/W
	0	0					0	0
Bit	7	6	5	4	3	2	1	0
Access								
Reset								

#### Bit 18 – ACKACT Acknowledge Action

This bit defines the Client's acknowledge behavior after an address or data byte is received from the Host. The acknowledge action is executed when a command is written to the CMD bits. If smart mode is enabled (CTRLB.SMEN = 1), the acknowledge action is performed when the DATA register is read.

ACKACT shall not be updated more than once between each peripheral interrupts request.

This bit is not enable-protected.

Value	Description
0	Send ACK
1	Send NACK

#### Bits 17:16 – CMD[1:0] Command

This bit field triggers the Client operation as the below. The CMD bits are strobe bits, and always read as zero. The operation is dependent on the Client interrupt flags, INTFLAG.DRDY and INTFLAG.AMATCH, in addition to STATUS.DIR.

All interrupt flags (INTFLAG.DRDY, INTFLAG.AMATCH and INTFLAG.PREC) are automatically cleared when a command is given.

This bit is not enable-protected.

**Table 34-4.** Command Description

CMD[1:0]	DIR	Action
0x0	X	(No action)
0x1	X	(Reserved)
0x2		Used to complete a transaction in response to a data interrupt (DRDY)
	0 (Host write)	Execute acknowledge action succeeded by waiting for any start (S/Sr) condition
	1 (Host read)	Wait for any start (S/Sr) condition

.....continued

CMD[1:0]	DIR	Action
0x3	Used in response to an address interrupt (AMATCH)	
	0 (Host write)	Execute acknowledge action succeeded by reception of next byte
1 (Host read)	Used in response to a data interrupt (DRDY)	
	0 (Host write)	Execute acknowledge action succeeded by reception of next byte
1 (Host read)	Execute a byte read operation followed by ACK/NACK reception	

### Bits 15:14 – AMODE[1:0] Address Mode

These bits set the addressing mode.

Value	Name	Description
0x0	MASK	The Client responds to the address written in ADDR.ADDR masked by the value in ADDR.ADDRMASK. See <a href="#">SERCOM – Serial Communication Interface</a> for additional information.
0x1	2_ADDRESSES	The Client responds to the two unique addresses in ADDR.ADDR and ADDR.ADDRMASK.
0x2	RANGE	The Client responds to the range of addresses between and including ADDR.ADDR and ADDR.ADDRMASK. ADDR.ADDR is the upper limit.
0x3	-	Reserved.

### Bit 9 – GCMD PMBus Group Command

This bit enables PMBus group command support. When enabled, the Stop Recived interrupt flag (INTFLAG.PREC) will be set when a STOP condition is detected if the Client has been addressed since the last STOP condition on the bus.

Value	Description
0	Group command is disabled.
1	Group command is enabled.

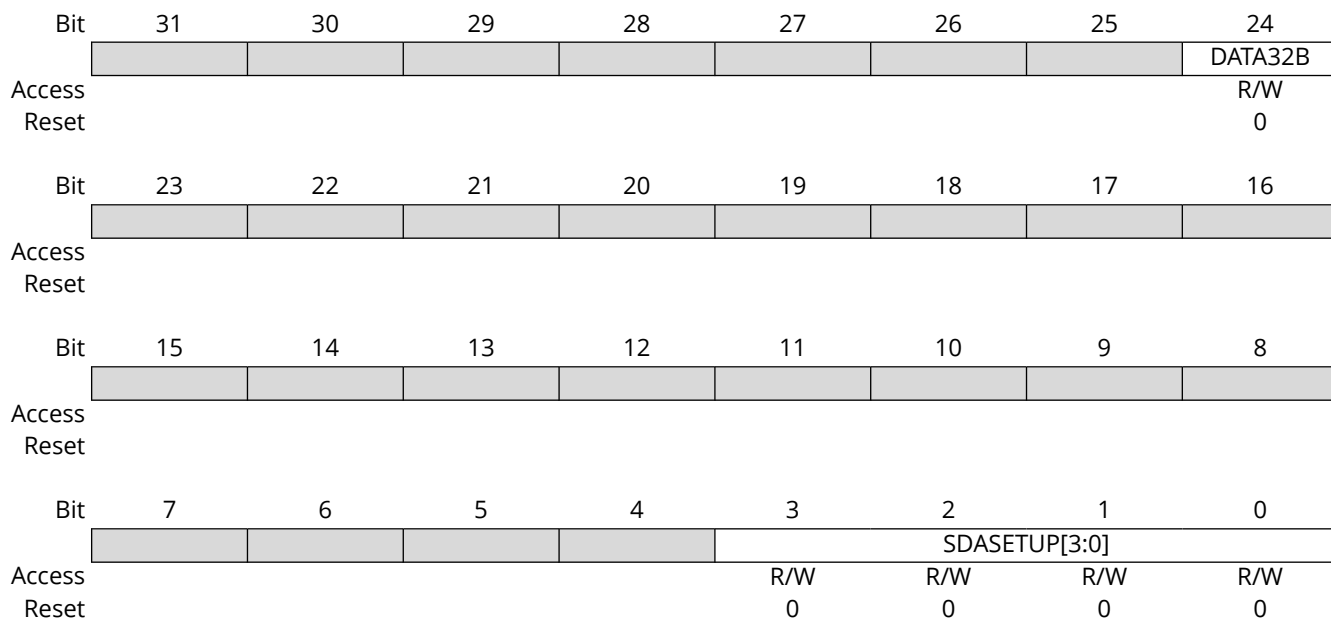
### Bit 8 – SMEN Smart Mode Enable

When smart mode is enabled, data is acknowledged automatically when DATA.DATA is read.

Value	Description
0	Smart mode is disabled.
1	Smart mode is enabled.

### 34.7.3 Control C

**Name:** CTRLC  
**Offset:** 0x08  
**Reset:** 0x00000000  
**Property:** PAC Write-Protection, Enable-Protected



#### Bit 24 – DATA32B Data 32 Bit

This bit enables 32-bit data writes and reads to/from the DATA register.

Value	Description
0	Data transaction to/from DATA are 8-bit in size
1	Data transaction to/from DATA are 32-bit in size

#### Bits 3:0 – SDASETUP[3:0] SDA Setup Time

These bits select the minimum SDA-to-SCL setup time, measured from the release of SDA to the release of SCL:

$$t_{SU:DAT} = (\text{CLK\_SERCOMx} \times \text{APB period}) \times (6 + 16 \times \text{SDASETUP})$$

### 34.7.4 Interrupt Enable Clear

**Name:** INTENCLR  
**Offset:** 0x14  
**Reset:** 0x00  
**Property:** PAC Write-Protection

This register allows the user to disable an interrupt without doing a read-modify-write operation. Changes in this register will also be reflected in the Interrupt Enable Set register (INTENSET).

Bit	7	6	5	4	3	2	1	0
	ERROR					DRDY	AMATCH	PREC
Access	R/W					R/W	R/W	R/W
Reset	0					0	0	0

#### Bit 7 – ERROR Error Interrupt Enable

Writing '0' to this bit has no effect.

Writing '1' to this bit will clear the Error Interrupt Enable bit, which disables the Error interrupt.

Value	Description
0	Error interrupt is disabled.
1	Error interrupt is enabled.

#### Bit 2 – DRDY Data Ready Interrupt Enable

Writing '0' to this bit has no effect.

Writing '1' to this bit will clear the Data Ready bit, which disables the Data Ready interrupt.

Value	Description
0	The Data Ready interrupt is disabled.
1	The Data Ready interrupt is enabled.

#### Bit 1 – AMATCH Address Match Interrupt Enable

Writing '0' to this bit has no effect.

Writing '1' to this bit will clear the Address Match Interrupt Enable bit, which disables the Address Match interrupt.

Value	Description
0	The Address Match interrupt is disabled.
1	The Address Match interrupt is enabled.

#### Bit 0 – PREC Stop Received Interrupt Enable

Writing '0' to this bit has no effect.

Writing '1' to this bit will clear the Stop Received Interrupt Enable bit, which disables the Stop Received interrupt.

Value	Description
0	The Stop Received interrupt is disabled.
1	The Stop Received interrupt is enabled.

### 34.7.5 Interrupt Enable Set

**Name:** INTENSET  
**Offset:** 0x16  
**Reset:** 0x00  
**Property:** PAC Write-Protection

This register allows the user to enable an interrupt without doing a read-modify-write operation. Changes in this register will also be reflected in the Interrupt Enable Clear register (INTENCLR).

Bit	7	6	5	4	3	2	1	0
	ERROR					DRDY	AMATCH	PREC
Access	R/W					R/W	R/W	R/W
Reset	0					0	0	0

#### Bit 7 – ERROR Error Interrupt Enable

Writing '0' to this bit has no effect.  
 Writing '1' to this bit will set the Error Interrupt Enable bit, which enables the Error interrupt.

Value	Description
0	Error interrupt is disabled.
1	Error interrupt is enabled.

#### Bit 2 – DRDY Data Ready Interrupt Enable

Writing '0' to this bit has no effect.  
 Writing '1' to this bit will set the Data Ready bit, which enables the Data Ready interrupt.

Value	Description
0	The Data Ready interrupt is disabled.
1	The Data Ready interrupt is enabled.

#### Bit 1 – AMATCH Address Match Interrupt Enable

Writing '0' to this bit has no effect.  
 Writing '1' to this bit will set the Address Match Interrupt Enable bit, which enables the Address Match interrupt.

Value	Description
0	The Address Match interrupt is disabled.
1	The Address Match interrupt is enabled.

#### Bit 0 – PREC Stop Received Interrupt Enable

Writing '0' to this bit has no effect.  
 Writing '1' to this bit will set the Stop Received Interrupt Enable bit, which enables the Stop Received interrupt.

Value	Description
0	The Stop Received interrupt is disabled.
1	The Stop Received interrupt is enabled.

### 34.7.6 Interrupt Flag Status and Clear

**Name:** INTFLAG  
**Offset:** 0x18  
**Reset:** 0x00  
**Property:** -

Bit	7	6	5	4	3	2	1	0
	ERROR					DRDY	AMATCH	PREC
Access	R/W					R/W	R/W	R/W
Reset	0					0	0	0

#### Bit 7 – ERROR Error

This bit is set when any error is detected. Errors that will set this flag have corresponding status flags in the STATUS register. The corresponding bits in STATUS are LENERR, SEXTTOUT, LOWTOUT, COLL, and BUSERR.

Writing '0' to this bit has no effect.

Writing '1' to this bit will clear the flag.

#### Bit 2 – DRDY Data Ready

This flag is set when a I<sup>2</sup>C Client byte transmission is successfully completed.

The flag is cleared by hardware when either:

- Writing to the DATA register.
- Reading the DATA register with Smart mode enabled.
- Writing a valid command to the CMD register.

Writing '0' to this bit has no effect.

Writing '1' to this bit will clear the Data Ready Interrupt flag.

#### Bit 1 – AMATCH Address Match

This flag is set when the I<sup>2</sup>C Client address match logic detects that a valid address has been received.

The flag is cleared by hardware when CTRL.CMD is written.

Writing '0' to this bit has no effect.

Writing '1' to this bit will clear the Address Match Interrupt flag. When cleared, an ACK/NACK will be sent according to CTRLB.ACKACT.

#### Bit 0 – PREC Stop Received

This flag is set when a Stop condition is detected for a transaction being processed. A Stop condition detected between a bus Host and another Client will not set this flag, unless the PMBus Group Command is enabled in the Control B register (CTRLB.GCMD=1).

This flag is cleared by hardware after a command is issued on the next address match.

Writing '0' to this bit has no effect.

Writing '1' to this bit will clear the Stop Received Interrupt flag.

### 34.7.7 Status

**Name:** STATUS  
**Offset:** 0x1A  
**Reset:** 0x0000  
**Property:** -

Bit	15	14	13	12	11	10	9	8
					LENERR	HS	SEXTTOUT	
Access					R/W	R/W	R/W	
Reset					0	0	0	
Bit	7	6	5	4	3	2	1	0
	CLKHOLD	LOWTOUT		SR	DIR	RXNACK	COLL	BUSERR
Access	R/W	R/W		R	R	R	R/W	R/W
Reset	0	0		0	0	0	0	0

#### Bit 11 – LENERR Transaction Length Error

This bit is set when the length counter is enabled (LENGTH.LENEN) and a STOP or repeated START is received before or after the length in LENGTH.LEN is reached.

This bit is cleared automatically when responding to a new start condition with ACK or NACK (CTRLB.CMD = 0x3).

**Note:** This bit is not cleared when INTFLAG.AMATCH is cleared. Write to '1' to clear LENERR status.

Writing a '0' to this bit has no effect.

Writing a '1' to this bit will clear the status.

#### Bit 10 – HS High-speed

This bit is set if the Client detects a START followed by a Host Code transmission.

Writing a '0' to this bit has no effect.

Writing a '1' to this bit will clear the status. However, this flag is automatically cleared when a STOP is received.

#### Bit 9 – SEXTTOUT Client SCL Low Extend Time-Out

This bit is set if a Client SCL low extend time-out occurs.

This bit is cleared automatically if responding to a new start condition with ACK or NACK (write 3 to CTRLB.CMD).

**Note:** This bit is not cleared when INTFLAG.AMATCH is cleared. Write to '1' to clear SEXTTOUT status.

Writing a '0' to this bit has no effect.

Writing a '1' to this bit will clear the status.

Value	Description
0	No SCL low extend time-out has occurred.
1	SCL low extend time-out has occurred.

#### Bit 7 – CLKHOLD Clock Hold

The Client Clock Hold bit (STATUS.CLKHOLD) is set when the Client is holding the SCL line low, stretching the I2C clock. Software should consider this bit a read-only status flag that is set when INTFLAG.DRDY or INTFLAG.AMATCH is set.

Writing a '0' to this bit has no effect.

Writing a '1' to this bit will clear the status.

**Note:** Do not clear this bit to preserve the current clock hold state.

This bit is automatically cleared when the corresponding interrupt is also cleared.

**Bit 6 – LOWTOUT** SCL Low Time-out

This bit is set if an SCL low time-out occurs.

This bit is cleared automatically if responding to a new start condition with ACK or NACK (write 3 to CTRLB.CMD).

**Note:** This bit is not cleared when INTFLAG.AMATCH is cleared. Write to '1' to clear LOWTOUT status.

Writing a '0' to this bit has no effect.

Writing a '1' to this bit will clear the status.

Value	Description
0	No SCL low time-out has occurred.
1	SCL low time-out has occurred.

**Bit 4 – SR** Repeated Start

When INTFLAG.AMATCH is raised due to an address match, SR indicates a repeated start or start condition.

This flag is only valid while the INTFLAG.AMATCH flag is one.

Value	Description
0	Start condition on last address match
1	Repeated start condition on last address match

**Bit 3 – DIR** Read / Write Direction

The Read/Write Direction (STATUS.DIR) bit stores the direction of the last address packet received from a Host.

Value	Description
0	Host write operation is in progress.
1	Host read operation is in progress.

**Bit 2 – RXNACK** Received Not Acknowledge

This bit indicates whether the last data packet sent was acknowledged or not.

Value	Description
0	Host responded with ACK.
1	Host responded with NACK.

**Bit 1 – COLL** Transmit Collision

If set, the I2C Client was not able to transmit a high data or NACK bit, the I2C Client will immediately release the SDA and SCL lines and wait for the next packet addressed to it.

This flag is intended for the SMBus address resolution protocol (ARP). A detected collision in non-ARP situations indicates that there has been a protocol violation, and should be treated as a bus error.

Note that this status will not trigger any interrupt, and should be checked by software to verify that the data were sent correctly.

This bit is cleared automatically if responding to an address match with an ACK or a NACK (writing 0x3 to CTRLB.CMD).

**Note:** This bit is not cleared when INTFLAG.AMATCH is cleared. Write to '1' to clear COLL status.

Writing a '0' to this bit has no effect.

Writing a '1' to this bit will clear the status.

Value	Description
0	No collision detected on last data byte sent.
1	Collision detected on last data byte sent.

**Bit 0 – BUSERR** Bus Error

The Bus Error bit (STATUS.BUSERR) indicates that an illegal bus condition has occurred on the bus, regardless of bus ownership. An illegal bus condition is detected if a protocol violating start, repeated start or stop is detected on the I2C bus lines. A start condition directly followed by a stop condition is one example of a protocol violation. If a time-out occurs during a frame, this is also considered a protocol violation, and will set STATUS.BUSERR.



This bit is cleared automatically if responding to an address match with an ACK or a NACK (writing 0x3 to CTRLB.CMD).

**Note:** This bit is not cleared when INTFLAG.AMATCH is cleared. Write to '1' to clear BUSERR status.

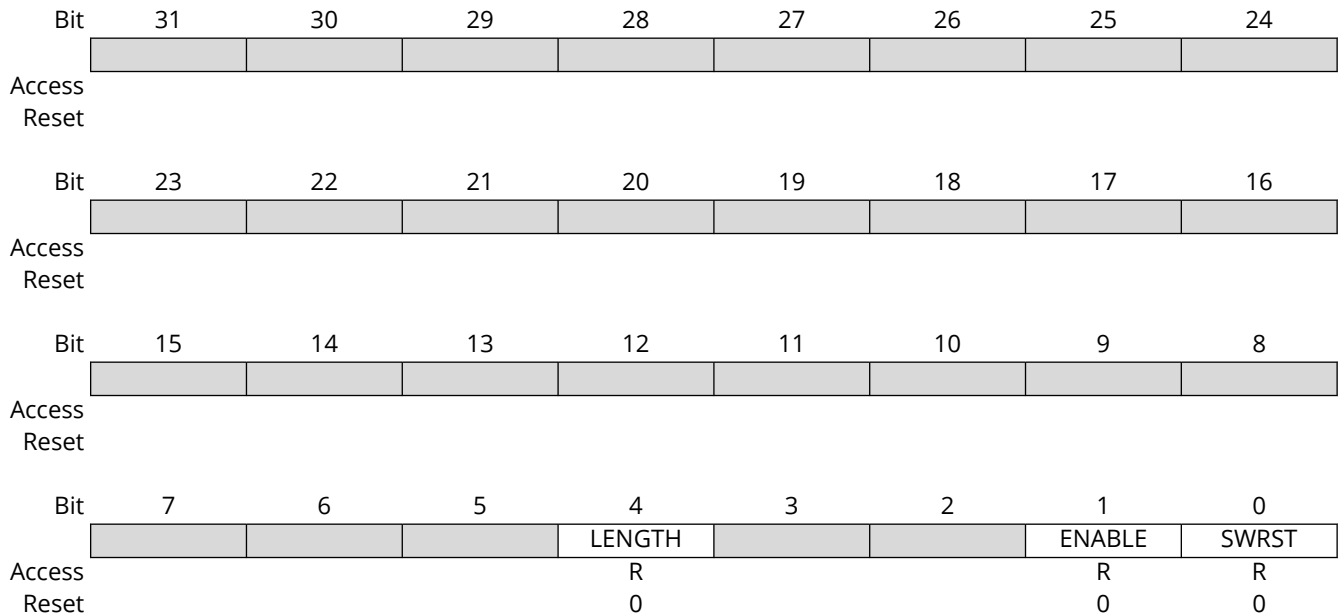
Writing a '1' to this bit will clear the status.

Writing a '0' to this bit has no effect.

Value	Description
0	No bus error detected.
1	Bus error detected.

### 34.7.8 Synchronization Busy

**Name:** SYNCBUSY  
**Offset:** 0x1C  
**Reset:** 0x00000000  
**Property:** -



#### Bit 4 - LENGTH LENGTH Synchronization Busy

Writing LENGTH requires synchronization. When written, this bit will be set until synchronization is complete. If LENGTH is written while SYNCBUSY.LENGTH is asserted, an APB error will be generated.

**Note:** In Client mode, the clock is only running during data transfer, so SYNCBUSY.LENGTH will remain asserted until the next data transfer begins.

Value	Description
0	LENGTH synchronization is not busy.
1	LENGTH synchronization is busy.

#### Bit 1 - ENABLE SERCOM Enable Synchronization Busy

Enabling and disabling the SERCOM (CTRLA.ENABLE) requires synchronization. When written, the SYNCBUSY.ENABLE bit will be set until synchronization is complete.

Value	Description
0	Enable synchronization is not busy.
1	Enable synchronization is busy.

#### Bit 0 - SWRST Software Reset Synchronization Busy

Resetting the SERCOM (CTRLA.SWRST) requires synchronization. When written, the SYNCBUSY.SWRST bit will be set until synchronization is complete.

Value	Description
0	SWRST synchronization is not busy.
1	SWRST synchronization is busy.

### 34.7.9 Length

**Name:** LENGTH  
**Offset:** 0x22  
**Reset:** 0x0000  
**Property:** PAC Write-Protection, Write-Synchronized

**Note:** This register is write-synchronized: SYNCBUSY.LENGTH must be checked to ensure the LENGTH register synchronization is complete.

Bit	15	14	13	12	11	10	9	8
								LENEN
Access								R/W
Reset								0
Bit	7	6	5	4	3	2	1	0
	LEN[7:0]							
Access	R/W	R/W	R/W	R/W	R/W	R/W	R/W	R/W
Reset	0	0	0	0	0	0	0	0

#### Bit 8 – LENEN Data Length Enable

In 32-bit Extension mode (CTRLC.DATA32B=1), this bit field enables the length counter.

Value	Description
0	Length counter is disabled.
1	Length counter is enabled.

#### Bits 7:0 – LEN[7:0] Data Length

In 32-bit Extension mode (CTRLC.DATA32B=1) with Data Length counting enabled (LENGTH.LENEN), this bit field configures the data length from 0 to 255 Bytes after which the flag INTFLAG.DRDY is raised.

### 34.7.10 Address

**Name:** ADDR  
**Offset:** 0x24  
**Reset:** 0x00000000  
**Property:** PAC Write-Protection, Enable-Protected

Bit	31	30	29	28	27	26	25	24	
							ADDRMASK[9:7]		
Access						R/W	R/W	R/W	
Reset						0	0	0	
Bit	23	22	21	20	19	18	17	16	
	ADDRMASK[6:0]								
Access	R/W	R/W	R/W	R/W	R/W	R/W	R/W		
Reset	0	0	0	0	0	0	0		
Bit	15	14	13	12	11	10	9	8	
	TENBITEN					ADDR[9:7]			
Access	R/W					R/W	R/W	R/W	
Reset	0					0	0	0	
Bit	7	6	5	4	3	2	1	0	
	ADDR[6:0]							GENCEN	
Access	R/W	R/W	R/W	R/W	R/W	R/W	R/W	R/W	
Reset	0	0	0	0	0	0	0	0	

#### Bits 26:17 – ADDRMASK[9:0] Address Mask

These bits act as a second address match register, an address mask register or the lower limit of an address range, depending on the CTRLB.AMODE setting.

#### Bit 15 – TENBITEN Ten Bit Addressing Enable

Value	Description
0	10-bit address recognition disabled.
1	10-bit address recognition enabled.

#### Bits 10:1 – ADDR[9:0] Address

These bits contain the I<sup>2</sup>C Client address used by the Client address match logic to determine if a Host has addressed the Client.

When using 7-bit addressing, the Client address is represented by ADDR[6:0].

When using 10-bit addressing (ADDR.TENBITEN=1), the Client address is represented by ADDR[9:0].

When the address match logic detects a match, INTFLAG.AMATCH is set and STATUS.DIR is updated to indicate whether it is a read or a write transaction.

#### Bit 0 – GENCEN General Call Address Enable

A general call address is an address consisting of all-zeroes, including the direction bit (Host write).

Value	Description
0	General call address recognition disabled.
1	General call address recognition enabled.

### 34.7.11 Data

**Name:** DATA  
**Offset:** 0x28  
**Reset:** 0x00000000  
**Property:** Read/Write

Bit	31	30	29	28	27	26	25	24
	DATA[31:24]							
Access	R/W	R/W	R/W	R/W	R/W	R/W	R/W	R/W
Reset	0	0	0	0	0	0	0	0
Bit	23	22	21	20	19	18	17	16
	DATA[23:16]							
Access	R/W	R/W	R/W	R/W	R/W	R/W	R/W	R/W
Reset	0	0	0	0	0	0	0	0
Bit	15	14	13	12	11	10	9	8
	DATA[15:8]							
Access	R/W	R/W	R/W	R/W	R/W	R/W	R/W	R/W
Reset	0	0	0	0	0	0	0	0
Bit	7	6	5	4	3	2	1	0
	DATA[7:0]							
Access	R/W	R/W	R/W	R/W	R/W	R/W	R/W	R/W
Reset	0	0	0	0	0	0	0	0

#### Bits 31:0 – DATA[31:0] Data

The Client data register I/O location (DATA.DATA) provides access to the Host transmit and receive data buffers. Reading valid data or writing data to be transmitted can be successfully done only when SCL is held low by the Client (STATUS.CLKHOLD is set). An exception occurs when reading the last data byte after the stop condition has been received.

Accessing DATA.DATA auto-triggers I<sup>2</sup>C bus operations. The operation performed depends on the state of CTRLB.ACKACT, CTRLB.SMEN and the type of access (read/write).

When CTRLC.DATA32B=1, read and write transactions from/to the DATA register are 32 bit in size. Otherwise, reads and writes are 8 bit.

### 34.8 Register Summary - I2C Host

Offset	Name	Bit Pos.	7	6	5	4	3	2	1	0
0x00	CTRLA	7:0	RUNSTDBY				MODE[2:0]		ENABLE	SWRST
		15:8								
		23:16	SEXTTOEN	MEXTTOEN	SDAHOLD[1:0]					PINOUT
		31:24		LOWTOUTEN	INACTOUT[1:0]		SCLSM		SPEED[1:0]	
0x04	CTRLB	7:0							QCEN	SMEN
		15:8						ACKACT	CMD[1:0]	
		23:16								
0x08	CTRLC	7:0								
		15:8								
		23:16								
		31:24								DATA32B
0x0C	BAUD	7:0	BAUD[7:0]							
		15:8	BAUDLOW[7:0]							
		23:16	HSBAUD[7:0]							
		31:24	HSBAUDLOW[7:0]							
0x10 ...	Reserved									
0x13	Reserved									
0x14	INTENCLR	7:0	ERROR						SB	MB
0x15	Reserved									
0x16	INTENSET	7:0	ERROR						SB	MB
0x17	Reserved									
0x18	INTFLAG	7:0	ERROR						SB	MB
0x19	Reserved									
0x1A	STATUS	7:0	CLKHOLD	LOWTOUT	BUSSTATE[1:0]			RXNACK	ARBLOST	BUSERR
		15:8						LENERR	SEXTTOUT	MEXTTOUT
0x1C	SYNCBUSY	7:0						SYSOP	ENABLE	SWRST
		15:8								
		23:16								
		31:24								
0x20 ...	Reserved									
0x24	ADDR	7:0	ADDR[7:0]							
		15:8	TENBITEN	HS	LENEN				ADDR[10:8]	
		23:16	LEN[7:0]							
		31:24								
0x28	DATA	7:0	DATA[7:0]							
		15:8	DATA[15:8]							
		23:16	DATA[23:16]							
		31:24	DATA[31:24]							
0x2C ...	Reserved									
0x2F	Reserved									
0x30	DBGCTRL	7:0								DBGSTOP

### 34.8.1 Control A

**Name:** CTRLA  
**Offset:** 0x00  
**Reset:** 0x00000000  
**Property:** PAC Write-Protection, Enable-Protected Bits, Write-Synchronized Bits

Bit	31	30	29	28	27	26	25	24
		LOWTOUTEN	INACTOUT[1:0]		SCLSM		SPEED[1:0]	
Access		R/W	R/W	R/W	R/W		R/W	R/W
Reset		0	0	0	0		0	0
Bit	23	22	21	20	19	18	17	16
	SEXTTOEN	MEXTTOEN	SDAHOLD[1:0]					PINOUT
Access	R/W	R/W	R/W	R/W				R/W
Reset	0	0	0	0				0
Bit	15	14	13	12	11	10	9	8
Access								
Reset								
Bit	7	6	5	4	3	2	1	0
	RUNSTDBY			MODE[2:0]			ENABLE	SWRST
Access	R/W			R/W	R/W	R/W	R/W	R/W
Reset	0			0	0	0	0	0

#### Bit 30 – LOWTOUTEN SCL Low Time-Out Enable

This bit enables the SCL low time-out. If SCL is held low for 25ms-35ms, the Host will release its clock hold, if enabled, and complete the current transaction. A stop condition will automatically be transmitted.

INTFLAG.SB or INTFLAG.MB will be set as normal, but the clock hold will be released. The STATUS.LOWTOUT and STATUS.BUSERR status bits will be set.

This bit is not synchronized.

Value	Description
0	Time-out disabled.
1	Time-out enabled.

#### Bits 29:28 – INACTOUT[1:0] Inactive Time-Out

If the inactive bus time-out is enabled and the bus is inactive for longer than the time-out setting, the bus state logic will be set to idle. An inactive bus arise when either an I<sup>2</sup>C Host or Client is holding the SCL low.

Enabling this option is necessary for SMBus compatibility, but can also be used in a non-SMBus set-up.

Calculated time-out periods are based on a 100kHz baud rate.

These bits are not synchronized.

Value	Name	Description
0x0	DISABLE	Disabled
0x1	55US	5-6 SCL cycle time-out (50-60µs)
0x2	105US	10-11 SCL cycle time-out (100-110µs)
0x3	205US	20-21 SCL cycle time-out (200-210µs)

#### Bit 27 – SCLSM SCL Clock Stretch Mode

This bit controls when SCL will be stretched for software interaction.

This bit is not synchronized.

Value	Description
0	SCL stretch according to <a href="#">Figure 34-5</a> .
1	SCL stretch only after ACK bit, <a href="#">Figure 34-5</a> .

**Bits 25:24 – SPEED[1:0]** Transfer Speed

These bits define bus speed.  
 These bits are not synchronized.

Value	Name	Description
0x0	STANDARD_AND_FAST_MODE	Standard-mode (Sm) up to 100 kHz and Fast-mode (Fm) up to 400 kHz
0x1	FASTPLUS_MODE	Fast-mode Plus (Fm+) up to 1 MHz
0x2	HIGH_SPEED_MODE	High-speed mode (Hs-mode) up to 3.4 MHz
0x3	-	Reserved

**Bit 23 – SEXTTOEN** Client SCL Low Extend Time-Out

This bit enables the Client SCL low extend time-out. If SCL is cumulatively held low for greater than 25ms from the initial START to a STOP, the Host will release its clock hold if enabled, and complete the current transaction. A STOP will automatically be transmitted. SB or MB will be set as normal, but CLKHOLD will be release. The MEXTTOUT and BUSERR status bits will be set.

This bit is not synchronized.

Value	Description
0	Time-out disabled
1	Time-out enabled

**Bit 22 – MEXTTOEN** Host SCL Low Extend Time-Out

This bit enables the Host SCL low extend time-out. If SCL is cumulatively held low for greater than 10ms from START-to-ACK, ACK-to-ACK, or ACK-to-STOP the Host will release its clock hold if enabled, and complete the current transaction. A STOP will automatically be transmitted. SB or MB will be set as normal, but CLKHOLD will be released. The MEXTTOUT and BUSERR status bits will be set.

This bit is not synchronized.

Value	Description
0	Time-out disabled
1	Time-out enabled

**Bits 21:20 – SDAHOLD[1:0]** SDA Hold Time

These bits define the SDA hold time with respect to the negative edge of SCL.  
 These bits are not synchronized.

Value	Name	Description
0x0	DISABLE	Disabled
0x1	75NS	50-100ns hold time
0x2	450NS	300-600ns hold time
0x3	600NS	400-800ns hold time

**Bit 16 – PINOUT** Pin Usage

This bit set the pin usage to either two- or four-wire operation:  
 This bit is not synchronized.

Value	Description
0	4-wire operation disabled.
1	4-wire operation enabled.

**Bit 7 – RUNSTDBY** Run in Standby

This bit defines the functionality in standby sleep mode.  
 This bit is not synchronized.



Value	Description
0	GCLK_SERCOMx_CORE is disabled and the I <sup>2</sup> C Host will not operate in standby sleep mode.
1	GCLK_SERCOMx_CORE is enabled in all sleep modes.

**Bits 4:2 – MODE[2:0] Operating Mode**

These bits must be written to 0x5 to select the I<sup>2</sup>C Host serial communication interface of the SERCOM.

These bits are not synchronized.

**Bit 1 – ENABLE Enable**

Due to synchronization, there is delay from writing CTRLA.ENABLE until the peripheral is enabled/disabled. The value written to CTRLA.ENABLE will read back immediately and the Synchronization Enable Busy bit in the Synchronization Busy register (SYNCBUSY.ENABLE) will be set. SYNCBUSY.ENABLE will be cleared when the operation is complete.

This bit is not enable-protected.

Value	Description
0	The peripheral is disabled or being disabled.
1	The peripheral is enabled.

**Bit 0 – SWRST Software Reset**

Writing '0' to this bit has no effect.

Writing '1' to this bit resets all registers in the SERCOM, except DBGCTRL, to their initial state, and the SERCOM will be disabled.

**Note:** Software Reset (CTRLA.SWRST = 1) is not functional when the SERCOM is not enabled (CTRLA.ENABLE = 0).

Writing '1' to CTRLA.SWRST will always take precedence, meaning that all other writes in the same write-operation will be discarded. Any register write access during the ongoing reset will result in an APB error. Reading any register will return the reset value of the register.

Due to synchronization there is a delay from writing CTRLA.SWRST until the reset is complete.

CTRLA.SWRST and SYNCBUSY.SWRST will both be cleared when the reset is complete.

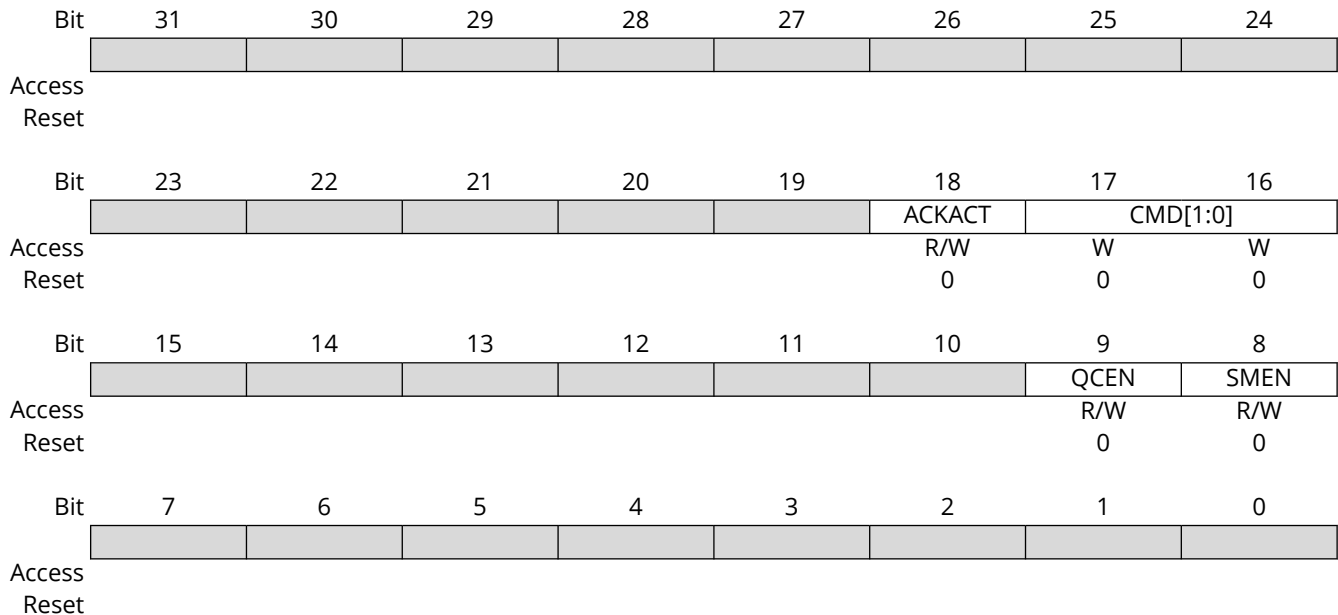
**Notes:**

1. When the CTRLA.SWRST is written, the user must poll the SYNCBUSY.SWRST bit to know when the reset operation is complete.
2. During a SWRST, access to registers or bits without the SWRST are disallowed until the SYNCBUSY.SWRST is cleared by hardware.
3. This bit is not Enable-Protected.

Value	Description
0	There is no reset operation ongoing.
1	The reset operation is ongoing.

### 34.8.2 Control B

**Name:** CTRLB  
**Offset:** 0x04  
**Reset:** 0x00000000  
**Property:** PAC Write-Protection, Enable-Protected Bits, Write-Synchronized Bits



#### Bit 18 – ACKACT Acknowledge Action

This bit defines the I<sup>2</sup>C Host's acknowledge behavior after a data byte is received from the I<sup>2</sup>C Client. The acknowledge action is executed when a command is written to CTRLB.CMD, or if Smart mode is enabled (CTRLB.SMEN is written to one), when DATA.DATA is read.

This bit is not enable-protected.  
 This bit is not write-synchronized.

Value	Description
0	Send ACK.
1	Send NACK.

#### Bits 17:16 – CMD[1:0] Command

Writing these bits triggers a Host operation as described below. The CMD bits are strobe bits, and always read as zero. The acknowledge action is only valid in Host Read mode. In Host Write mode, a command will only result in a repeated Start or Stop condition. The CTRLB.ACKACT bit and the CMD bits can be written at the same time, and then the acknowledge action will be updated before the command is triggered.

Commands can only be issued when either the Client on Bus Interrupt flag (INTFLAG.SB) or Host on Bus Interrupt flag (INTFLAG.MB) is '1'.

If CMD 0x1 is issued, a repeated start will be issued followed by the transmission of the current address in ADDR.ADDR. If another address is desired, ADDR.ADDR must be written instead of the CMD bits. This will trigger a repeated start followed by transmission of the new address.

Issuing a command will set the System Operation bit in the Synchronization Busy register (SYNCBUSY.SYSOP).

**Table 34-5. Command Description**

CMD[1:0]	Direction	Action
0x0	X	(No action)

.....continued

CMD[1:0]	Direction	Action
0x1	X	Execute acknowledge action succeeded by repeated Start
0x2	0 (Write)	No operation
	1 (Read)	Execute acknowledge action succeeded by a byte read operation
0x3	X	Execute acknowledge action succeeded by issuing a Stop condition

These bits are not enable-protected.

**Bit 9 – QCEN** Quick Command Enable

This bit is not write-synchronized.



**Important:** The use of the Quick Command mode (CTRLB.QCEN = 1) is only allowed if SCL Stretch Mode is CTRLA.SCLSM=0 which makes the Quick Command feature not available in High-Speed mode.

Value	Description
0	Quick Command is disabled.
1	Quick Command is enabled.

**Bit 8 – SMEN** Smart Mode Enable

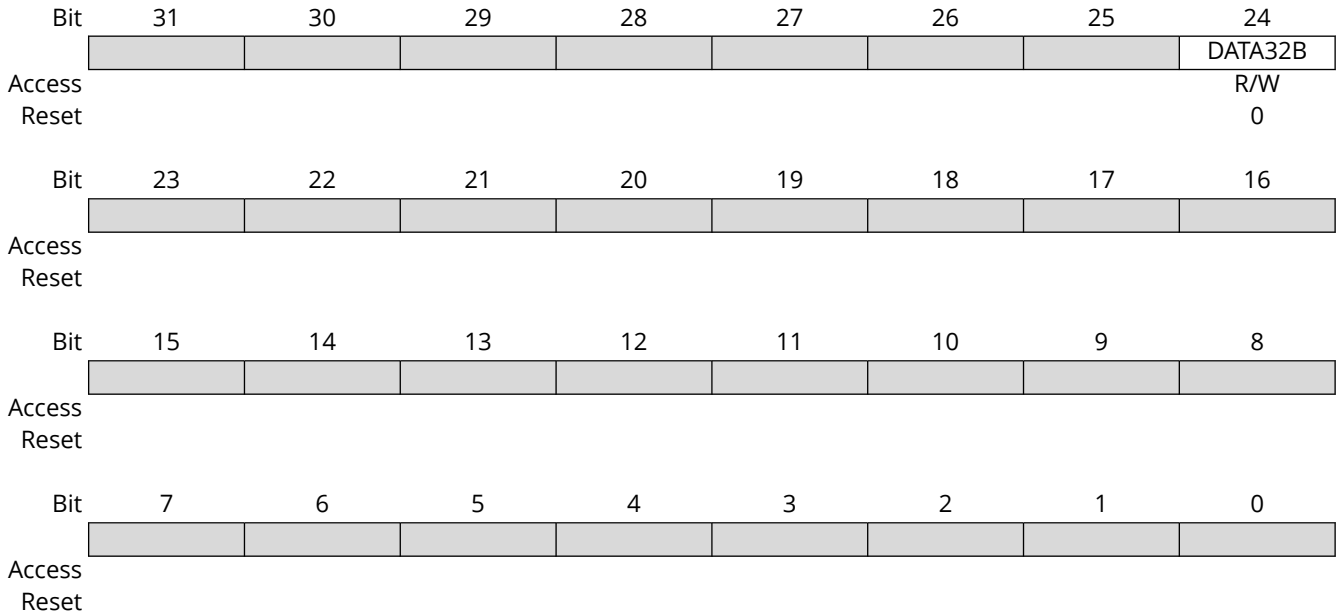
When Smart mode is enabled, acknowledge action is sent when DATA.DATA is read.

This bit is not write-synchronized.

Value	Description
0	Smart mode is disabled.
1	Smart mode is enabled.

### 34.8.3 Control C

**Name:** CTRLC  
**Offset:** 0x08  
**Reset:** 0x00000000  
**Property:** PAC Write-Protection, Enable-Protected



#### Bit 24 - DATA32B Data 32 Bit

This bit enables 32-bit data writes and reads to/from the DATA register.

Value	Description
0	Data transactions to/from DATA are 8-bit in size
1	Data transactions to/from DATA are 32-bit in size

### 34.8.4 Baud Rate

**Name:** BAUD  
**Offset:** 0x0C  
**Reset:** 0x0000  
**Property:** PAC Write-Protection, Enable-Protected

Bit	31	30	29	28	27	26	25	24
	HSBAUDLOW[7:0]							
Access	R/W	R/W	R/W	R/W	R/W	R/W	R/W	R/W
Reset	0	0	0	0	0	0	0	0
Bit	23	22	21	20	19	18	17	16
	HSBAUD[7:0]							
Access	R/W	R/W	R/W	R/W	R/W	R/W	R/W	R/W
Reset	0	0	0	0	0	0	0	0
Bit	15	14	13	12	11	10	9	8
	BAUDLOW[7:0]							
Access	R/W	R/W	R/W	R/W	R/W	R/W	R/W	R/W
Reset	0	0	0	0	0	0	0	0
Bit	7	6	5	4	3	2	1	0
	BAUD[7:0]							
Access	R/W	R/W	R/W	R/W	R/W	R/W	R/W	R/W
Reset	0	0	0	0	0	0	0	0

#### Bits 31:24 – HSBAUDLOW[7:0] High Speed Host Baud Rate Low

HSBAUDLOW non-zero: HSBAUDLOW indicates the SCL low time in High-speed mode according to  $HSBAUDLOW = f_{GCLK} \cdot T_{LOW} - 1$   
 HSBAUDLOW equal to zero: The HSBAUD register is used to time  $T_{LOW}$ ,  $T_{HIGH}$ ,  $T_{SU;STO}$ ,  $T_{HD;STA}$  and  $T_{SU;STA}$ .  $T_{BUF}$  is timed by the BAUD register.

#### Bits 23:16 – HSBAUD[7:0] High Speed Host Baud Rate

This bit field indicates the SCL high time in High-speed mode according to the following formula. When HSBAUDLOW is zero,  $T_{LOW}$ ,  $T_{HIGH}$ ,  $T_{SU;STO}$ ,  $T_{HD;STA}$  and  $T_{SU;STA}$  are derived using this formula.  $T_{BUF}$  is timed by the BAUD register.  
 $HSBAUD = f_{GCLK} \cdot T_{HIGH} - 1$

#### Bits 15:8 – BAUDLOW[7:0] Host Baud Rate Low

If this bit field is non-zero, the SCL low time will be described by the value written. For more information on how to calculate the frequency, see SERCOM [31.6.2.3. Clock Generation – Baud-Rate Generator](#).

#### Bits 7:0 – BAUD[7:0] Host Baud Rate

This bit field is used to derive the SCL high time if BAUD.BAUDLOW is non-zero. If BAUD.BAUDLOW is zero, BAUD will be used to generate both high and low periods of the SCL. For more information on how to calculate the frequency, see SERCOM [31.6.2.3. Clock Generation – Baud-Rate Generator](#).

### 34.8.5 Interrupt Enable Clear

**Name:** INTENCLR  
**Offset:** 0x14  
**Reset:** 0x00  
**Property:** PAC Write-Protection

This register allows the user to disable an interrupt without doing a read-modify-write operation. Changes in this register will also be reflected in the Interrupt Enable Set register (INTENSET).

Bit	7	6	5	4	3	2	1	0
	ERROR						SB	MB
Access	R/W						R/W	R/W
Reset	0						0	0

#### Bit 7 – ERROR Error Interrupt Enable

Writing '0' to this bit has no effect.

Writing '1' to this bit will clear the Error Interrupt Enable bit, which disables the Error interrupt.

Value	Description
0	Error interrupt is disabled.
1	Error interrupt is enabled.

#### Bit 1 – SB Client on Bus Interrupt Enable

Writing '0' to this bit has no effect.

Writing '1' to this bit will clear the Client on Bus Interrupt Enable bit, which disables the Client on Bus interrupt.

Value	Description
0	The Client on Bus interrupt is disabled.
1	The Client on Bus interrupt is enabled.

#### Bit 0 – MB Host on Bus Interrupt Enable

Writing '0' to this bit has no effect.

Writing '1' to this bit will clear the Host on Bus Interrupt Enable bit, which disables the Host on Bus interrupt.

Value	Description
0	The Host on Bus interrupt is disabled.
1	The Host on Bus interrupt is enabled.

### 34.8.6 Interrupt Enable Set

**Name:** INTENSET  
**Offset:** 0x16  
**Reset:** 0x00  
**Property:** PAC Write-Protection

This register allows the user to enable an interrupt without doing a read-modify-write operation. Changes in this register will also be reflected in the Interrupt Enable Clear register (INTENCLR).

Bit	7	6	5	4	3	2	1	0
	ERROR						SB	MB
Access	R/W						R/W	R/W
Reset	0						0	0

#### Bit 7 – ERROR Error Interrupt Enable

Writing '0' to this bit has no effect.

Writing '1' to this bit will set the Error Interrupt Enable bit, which enables the Error interrupt.

Value	Description
0	Error interrupt is disabled.
1	Error interrupt is enabled.

#### Bit 1 – SB Client on Bus Interrupt Enable

Writing '0' to this bit has no effect.

Writing '1' to this bit will set the Client on Bus Interrupt Enable bit, which enables the Client on Bus interrupt.

Value	Description
0	The Client on Bus interrupt is disabled.
1	The Client on Bus interrupt is enabled.

#### Bit 0 – MB Host on Bus Interrupt Enable

Writing '0' to this bit has no effect.

Writing '1' to this bit will set the Host on Bus Interrupt Enable bit, which enables the Host on Bus interrupt.

Value	Description
0	The Host on Bus interrupt is disabled.
1	The Host on Bus interrupt is enabled.

### 34.8.7 Interrupt Flag Status and Clear

**Name:** INTFLAG  
**Offset:** 0x18  
**Reset:** 0x00  
**Property:** -

Bit	7	6	5	4	3	2	1	0
	ERROR						SB	MB
Access	R/W						R/W	R/W
Reset	0						0	0

#### Bit 7 – ERROR Error

This flag is cleared by writing '1' to it.

This bit is set when any error is detected. Errors that will set this flag have corresponding status bits in the STATUS register. These status bits are LENERR, SEXTTOUT, MEXTTOUT, LOWTOUT, ARBLOST, and BUSERR.

Writing '0' to this bit has no effect.

Writing '1' to this bit will clear the flag.

#### Bit 1 – SB Client on Bus

The Client on Bus flag (SB) is set when a byte is successfully received in Host Read mode, for example, no arbitration lost or bus error occurred during the operation. When this flag is set, the Host forces the SCL line low, stretching the I<sup>2</sup>C clock period. The SCL line will be released and SB will be cleared on one of the following actions:

- Writing to ADDR.ADDR
- Writing to DATA.DATA
- Reading DATA.DATA when Smart mode is enabled (CTRLB.SMEN)
- Writing a valid command to CTRLB.CMD

Writing '1' to this bit location will clear the SB flag. The transaction will not continue or be terminated until one of the above actions is performed.

Writing '0' to this bit has no effect.

#### Bit 0 – MB Host on Bus

This flag is set when a byte is transmitted in Host Write mode. The flag is set regardless of the occurrence of a bus error or an Arbitration Lost condition. MB is also set when arbitration is lost during sending of NACK in Host Read mode, or when issuing a Start condition if the bus state is unknown. When this flag is set and arbitration is not lost, the Host forces the SCL line low, stretching the I<sup>2</sup>C clock period. The SCL line will be released and MB will be cleared on one of the following actions:

- Writing to ADDR.ADDR
- Writing to DATA.DATA
- Reading DATA.DATA when Smart mode is enabled (CTRLB.SMEN)
- Writing a valid command to CTRLB.CMD

Writing '1' to this bit location will clear the MB flag. The transaction will not continue or be terminated until one of the above actions is performed.

Writing '0' to this bit has no effect.



### 34.8.8 Status

**Name:** STATUS  
**Offset:** 0x1A  
**Reset:** 0x0000  
**Property:** Write-Synchronized

**Note:** This register is write-synchronized: SYNCBUSY.STATUS must be checked to ensure the STATUS register synchronization is complete.

Bit	15	14	13	12	11	10	9	8
						LENERR	SEXTTOUT	MEXTTOUT
Access						R/W	R/W	R/W
Reset						0	0	0
Bit	7	6	5	4	3	2	1	0
	CLKHOLD	LOWTOUT	BUSSTATE[1:0]			RXNACK	ARBLOST	BUSERR
Access	R/W	R/W	R/W	R/W		R	R/W	R/W
Reset	0	0	0	0		0	0	0

#### Bit 10 – LENERR Transaction Length Error

This bit is set when automatic length is used for a DMA and/or 32-bit transaction and the Client sends a NACK before ADDR.LEN bytes have been written by the Host.  
 Writing '1' to this bit location will clear STATUS.LENERR. This flag is automatically cleared when writing to the ADDR register.  
 Writing '0' to this bit has no effect.  
 This bit is not write-synchronized.

#### Bit 9 – SEXTTOUT Client SCL Low Extend Time-Out

This bit is set if a Client SCL low extend time-out occurs.  
 This bit is automatically cleared when writing to the ADDR register.  
 Writing '1' to this bit location will clear SEXTTOUT. Normal use of the I<sup>2</sup>C interface does not require the SEXTTOUT flag to be cleared by this method.  
 Writing '0' to this bit has no effect.  
 This bit is not write-synchronized.

#### Bit 8 – MEXTTOUT Host SCL Low Extend Time-Out

This bit is set if a Host SCL low time-out occurs.  
 Writing '1' to this bit location will clear STATUS.MEXTTOUT. This flag is automatically cleared when writing to the ADDR register.  
 Writing '0' to this bit has no effect.  
 This bit is not write-synchronized.

#### Bit 7 – CLKHOLD Clock Hold

This bit is set when the Host is holding the SCL line low, stretching the I<sup>2</sup>C clock. Software should consider this bit when INTFLAG.SB or INTFLAG.MB is set.  
 This bit is cleared when the corresponding Interrupt flag is cleared and the next operation is given.  
 Writing '0' to this bit has no effect.  
 Writing a '1' to this bit will clear the status.  
**Note:** Do not clear this bit to preserve the current clock hold state.  
 This bit is not write-synchronized.

#### Bit 6 – LOWTOUT SCL Low Time-Out

This bit is set if an SCL low time-out occurs.

Writing '1' to this bit location will clear this bit. This flag is automatically cleared when writing to the ADDR register.  
 Writing '0' to this bit has no effect.  
 This bit is not write-synchronized.

**Bits 5:4 - BUSSTATE[1:0] Bus State**

These bits indicate the current I<sup>2</sup>C Bus state.  
 When in UNKNOWN state, writing 0x1 to BUSSTATE forces the bus state into the IDLE state. The bus state cannot be forced into any other state.  
 Writing BUSSTATE to idle will set SYNCBUSY.SYSOP.

Value	Name	Description
0x0	UNKNOWN	The Bus state is unknown to the I <sup>2</sup> C Host and will wait for a Stop condition to be detected or wait to be forced into an Idle state by software
0x1	IDLE	The Bus state is waiting for a transaction to be initialized
0x2	OWNER	The I <sup>2</sup> C Host is the current owner of the bus
0x3	BUSY	Some other I <sup>2</sup> C Host owns the bus

**Bit 2 - RXNACK Received Not Acknowledge**

This bit indicates whether the last address or data packet sent was acknowledged or not.  
 Writing '0' to this bit has no effect.  
 Writing '1' to this bit has no effect.  
 This bit is not write-synchronized.

Value	Description
0	Client responded with ACK.
1	Client responded with NACK.

**Bit 1 - ARBLOST Arbitration Lost**

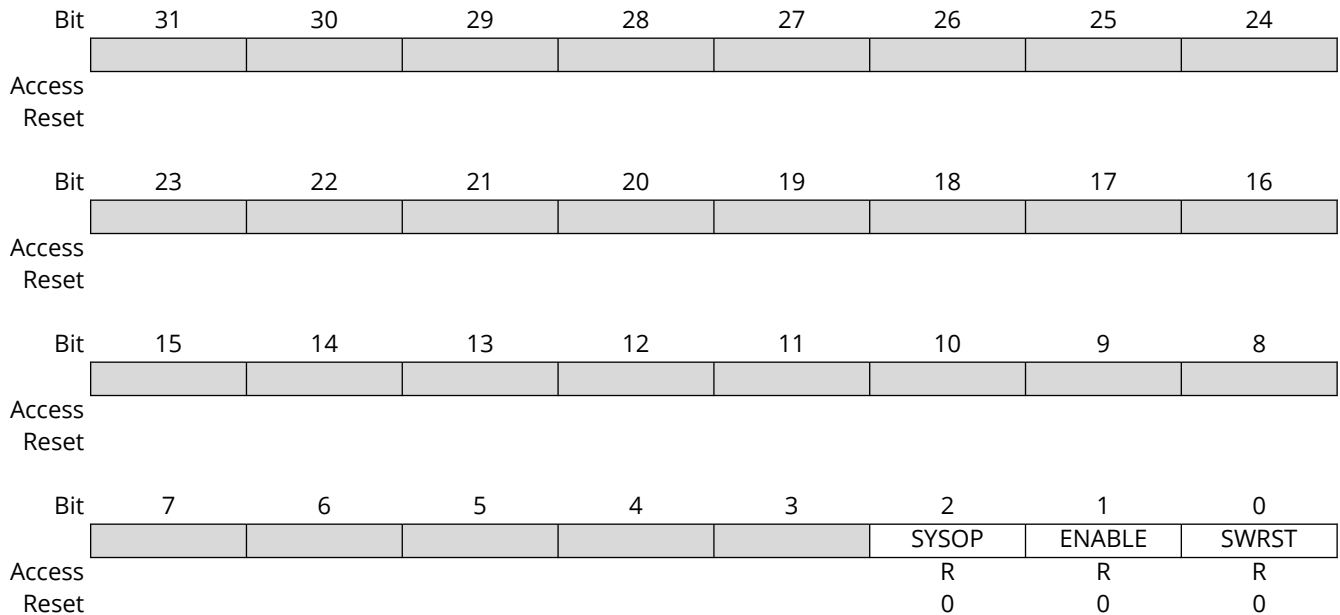
This bit is set if arbitration is lost while transmitting a high data bit or a NACK bit, or while issuing a Start or Repeated Start condition on the bus. The Host on Bus Interrupt flag (INTFLAG.MB) will be set when STATUS.ARBLOST is set.  
 Writing the ADDR.ADDR register will automatically clear STATUS.ARBLOST.  
 Writing '0' to this bit has no effect.  
 Writing '1' to this bit will clear it.  
 This bit is not write-synchronized.

**Bit 0 - BUSERR Bus Error**

This bit indicates that an illegal Bus condition has occurred on the bus, regardless of bus ownership. An illegal Bus condition is detected if a protocol violating start, repeated start or stop is detected on the I<sup>2</sup>C bus lines. A Start condition directly followed by a Stop condition is one example of a protocol violation. If a time-out occurs during a frame, this is also considered a protocol violation, and will set BUSERR.  
 If the I<sup>2</sup>C Host is the bus owner at the time a bus error occurs, STATUS.ARBLOST and INTFLAG.MB will be set in addition to BUSERR.  
 Writing the ADDR.ADDR register will automatically clear the BUSERR flag.  
 Writing '0' to this bit has no effect.  
 Writing '1' to this bit will clear it.  
 This bit is not write-synchronized.

### 34.8.9 Synchronization Busy

**Name:** SYNCBUSY  
**Offset:** 0x1C  
**Reset:** 0x00000000



#### Bit 2 – SYSOP System Operation Synchronization Busy

Writing CTRLB.COMD, STATUS.BUSSTATE, ADDR, or DATA when the SERCOM is enabled requires synchronization. When written, the SYNCBUSY.SYSOP bit will be set until synchronization is complete.

Value	Description
0	System operation synchronization is not busy.
1	System operation synchronization is busy.

#### Bit 1 – ENABLE SERCOM Enable Synchronization Busy

Enabling and disabling the SERCOM (CTRLA.ENABLE) requires synchronization. When written, the SYNCBUSY.ENABLE bit will be set until synchronization is complete.

Value	Description
0	Enable synchronization is not busy.
1	Enable synchronization is busy.

#### Bit 0 – SWRST Software Reset Synchronization Busy

Resetting the SERCOM (CTRLA.SWRST) requires synchronization. When written, the SYNCBUSY.SWRST bit will be set until synchronization is complete.

Value	Description
0	SWRST synchronization is not busy.
1	SWRST synchronization is busy.

### 34.8.10 Address

**Name:** ADDR  
**Offset:** 0x24  
**Reset:** 0x0000  
**Property:** Write-Synchronized

**Note:** This register is write-synchronized: SYNCBUSY.ADDR must be checked to ensure the ADDR register synchronization is complete.

Bit	31	30	29	28	27	26	25	24
Access								
Reset								
Bit	23	22	21	20	19	18	17	16
Access	LEN[7:0]							
Reset	0	0	0	0	0	0	0	0
Bit	15	14	13	12	11	10	9	8
Access	TENBITEN	HS	LENEN			ADDR[10:8]		
Reset	0	0	0			0	0	0
Bit	7	6	5	4	3	2	1	0
Access	ADDR[7:0]							
Reset	0	0	0	0	0	0	0	0

#### Bits 23:16 – LEN[7:0] Transaction Length

These bits define the transaction length of a DMA and/or 32-bit transaction from 0 to 255 bytes. The Transfer Length Enable (LENEN) bit must be written to '1' in order to use DMA.

#### Bit 15 – TENBITEN Ten Bit Addressing Enable

This bit enables 10-bit addressing. This bit can be written simultaneously with ADDR to indicate a 10-bit or 7-bit address transmission.

Value	Description
0	10-bit addressing disabled.
1	10-bit addressing enabled.

#### Bit 14 – HS High Speed

This bit enables High-speed mode for the current transfer from repeated START to STOP. This bit can be written simultaneously with ADDR for a high speed transfer.

Value	Description
0	High-speed transfer disabled.
1	High-speed transfer enabled.

#### Bit 13 – LENEN Transfer Length Enable

Value	Description
0	Automatic transfer length disabled.
1	Automatic transfer length enabled.

#### Bits 10:0 – ADDR[10:0] Address

When ADDR is written, the consecutive operation will depend on the bus state:

UNKNOWN: INTFLAG.MB and STATUS.BUSERR are set, and the operation is terminated.

BUSY: The I<sup>2</sup>C Host will await further operation until the bus becomes IDLE.

IDLE: The I<sup>2</sup>C Host will issue a start condition followed by the address written in ADDR. If the address is acknowledged, SCL is forced and held low, and STATUS.CLKHOLD and INTFLAG.MB are set.

OWNER: A repeated start sequence will be performed. If the previous transaction was a read, the acknowledge action is sent before the repeated start bus condition is issued on the bus. Writing ADDR to issue a repeated start is performed while INTFLAG.MB or INTFLAG.SB is set.

STATUS.BUSERR, STATUS.ARBLOST, INTFLAG.MB and INTFLAG.SB will be cleared when ADDR is written.

The ADDR register can be read at any time without interfering with ongoing bus activity, as a read access does not trigger the Host logic to perform any bus protocol related operations.

The I<sup>2</sup>C Host control logic uses bit 0 of ADDR as the bus protocol's read/write flag (R/W); 0 for write and 1 for read.

### 34.8.11 Data

**Name:** DATA  
**Offset:** 0x28  
**Reset:** 0x00000000  
**Property:** Read/Write

Bit	31	30	29	28	27	26	25	24
	DATA[31:24]							
Access	R/W	R/W	R/W	R/W	R/W	R/W	R/W	R/W
Reset	0	0	0	0	0	0	0	0
Bit	23	22	21	20	19	18	17	16
	DATA[23:16]							
Access	R/W	R/W	R/W	R/W	R/W	R/W	R/W	R/W
Reset	0	0	0	0	0	0	0	0
Bit	15	14	13	12	11	10	9	8
	DATA[15:8]							
Access	R/W	R/W	R/W	R/W	R/W	R/W	R/W	R/W
Reset	0	0	0	0	0	0	0	0
Bit	7	6	5	4	3	2	1	0
	DATA[7:0]							
Access	R/W	R/W	R/W	R/W	R/W	R/W	R/W	R/W
Reset	0	0	0	0	0	0	0	0

#### Bits 31:0 – DATA[31:0] Data

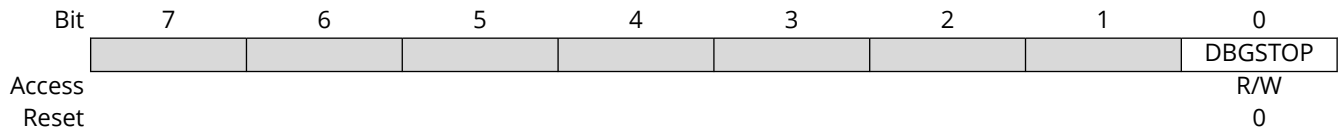
The Host data register I/O location (DATA) provides access to the Host transmit and receive data buffers. Reading valid data or writing data to be transmitted can be successfully done only when SCL is held low by the Host (STATUS.CLKHOLD is set). An exception is reading the last data byte after the stop condition has been sent.

Accessing DATA.DATA auto-triggers I<sup>2</sup>C bus operations. The operation performed depends on the state of CTRLB.ACKACT, CTRLB.SMEN and the type of access (read/write).

When CTRLC.DATA32B=1, read and write transactions from/to the DATA register are 32 bit in size. Otherwise, reads and writes are 8 bit.

### 34.8.12 Debug Control

**Name:** DBGCTRL  
**Offset:** 0x30  
**Reset:** 0x00  
**Property:** PAC Write-Protection



#### Bit 0 - DBGSTOP Debug Stop Mode

This bit controls functionality when the CPU is halted by an external debugger.

Value	Description
0	The baud-rate generator continues normal operation when the CPU is halted by an external debugger.
1	The baud-rate generator is halted when the CPU is halted by an external debugger.

## 35. Quad Serial Peripheral Interface (QSPI)

### 35.1 Overview

The Quad SPI Interface (QSPI) circuit is a synchronous serial data link that provides communication with external devices in Host mode.

The QSPI can be used in “SPI mode” to interface serial peripherals, such as ADCs, DACs, LCD controllers and sensors, or in “Serial Memory Mode” to interface serial Flash memories.

The QSPI allows the system to execute code directly from a serial Flash memory (XIP) without code shadowing to SRAM. The serial Flash memory mapping is seen in the system as other memories (ROM, SRAM, DRAM, embedded Flash memories, and so on).

With the support of the quad-SPI protocol, the QSPI allows the system to use high performance serial Flash memories which are small and inexpensive, in place of larger and more expensive parallel Flash memories.

### 35.2 Features

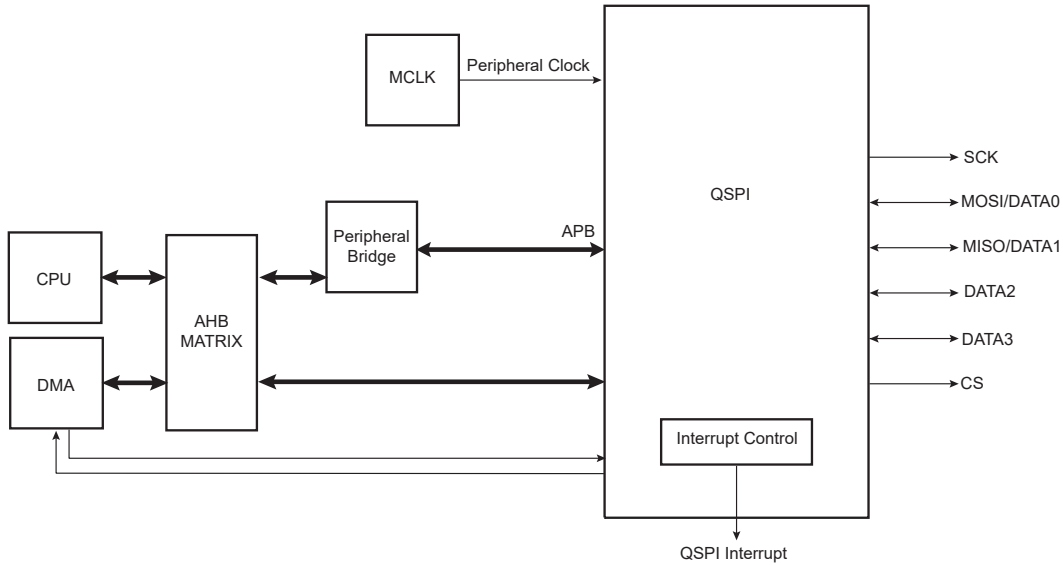
The following are key features of the QSPI:

- Host SPI Interface:
  - Programmable Clock Phase and Clock Polarity
  - Programmable transfer delays between consecutive transfers, between clock and data, between deactivation and activation of chip select (CS)
- SPI Mode:
  - To use serial peripherals, such as ADCs, DACs, LCD controllers, CAN controllers, and sensors
  - 8-bit, 16-bit, or 32-bit programmable data length
- Serial Memory Mode:
  - To use serial Flash memories operating in single-bit SPI, Dual SPI, and Quad SPI
  - Supports “execute in place” (XIP). The system can execute code directly from a Serial Flash memory.
  - Flexible Instruction register, to be compatible with all Serial Flash memories
  - 32-bit Address mode (default is 24-bit address) to support Serial Flash memories larger than 128 Mbit
  - Continuous Read mode
  - Scrambling/Unscrambling “On-the-Fly”
  - Double data rate support (read only)
- Connection to DMA Channel Capabilities Optimizes Data Transfers
  - One channel for the receiver and one channel for the transmitter
- Register Write Protection



### 35.3 Block Diagram

Figure 35-1. QSPI Block Diagram



### 35.4 Signal Description

Table 35-1. Quad-SPI Signals

Signal	Description	Type
SCK	Serial Clock	Output
CS	Chip Select	Output
MOSI(DATA0)	Data Output (Data Input Output 0)	Output (Input/Output)
MISO(DATA1)	Data Input (Data Input Output 1)	Input (Input/Output)
DATA2	Data Input Output 2	Input/Output
DATA3	Data Input Output 3	Input/Output

**Note:** MOSI and MISO are used for single-bit SPI operation

**Note:** DATA0-DATA1 are used for Dual SPI operation

**Note:** DATA0-DATA3 are used for Quad SPI operation

Refer to the [pinout](#) table for details on the pin mapping for this peripheral. One signal can be mapped to one of several pins.

### 35.5 Peripheral Dependencies

<b>Peripheral Name</b>	QSPI - Quad Serial Peripheral Interface
<b>Base Address</b>	0x4200_3400 (Peripheral Bus C)
<b>NVIC IRQ Index:Source</b>	134 : RXC, DRE, TXC, ERROR, CSRISRE, INSTREND
<b>MCLK APB Clock (1)</b>	CLK_QSPI_AHB, Enabled, AHBMASK.QSPI CLK_QSPI2X_AHB Enabled, AHBMASK.QSPI_2X APBCMASK.QSPI, Enabled, APBCMASK.QSPI
<b>GCLK Peripheral Channel Index:Clock Name</b>	n/a
<b>PAC Peripheral Identifier (PAC.WRCTRL)</b>	77
<b>DMA Trigger Index:Source (DMAC.CHCTRLAk,k=0,1,...31)</b>	83 : RX; 84 : TX

**Note:**

1. Clock Name, Default State, Mask Field.

### 35.5.1 I/O Lines

Using the QSPI I/O lines requires the I/O pins to be configured.

### 35.5.2 Power Management

The QSPI will continue to operate in any Sleep mode where the selected source clock is running. The QSPI interrupts can be used to wake up the device from sleep modes. Refer to the [Power Manager](#) chapter for details on the different sleep modes.

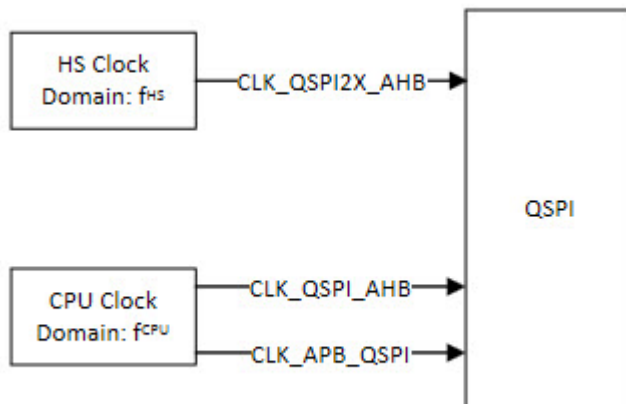
### 35.5.3 Clocks

The QSPI bus clock (CLK\_QSPI\_APB) can be enabled and disabled in the Main Clock module, and the default state of CLK\_QSPI\_APB can be found in the [Peripheral Clock Masking](#) section in the MCLK chapter.

An AHB clock (CLK\_QSPI\_AHB) is required to clock the QSPI. This clock can be enabled and disabled in the Main Clock module, and the default state of CLK\_QSPI\_AHB can be found in the Peripheral Clock Masking section in the MCLK chapter.

A FAST clock (CLK\_QSPI2X\_AHB) is required to clock the QSPI. This clock can be enabled and disabled in the Main Clock module, and the default state of CLK\_QSPI2X\_AHB can be found in the Peripheral Clock Masking section in the MCLK chapter. This clock is derived from the High-Speed Clock Domain (HS Clock Domain, frequency  $f_{HS}$ ).

**Figure 35-2.** QSPI Clock Organization



**Important:** The CLK\_QSPI2x\_AHB must be 2 times faster to CLK\_QSPI\_AHB when the QSPI is operated in DDR mode. In SDR, the CLK\_QSPI2x\_AHB is not used.

CLK\_QSPI\_APB, CLK\_QSPI\_AHB, and CLK\_QSPI2X\_AHB, respectively, are all synchronous, but can be divided by a prescaler and may run even when the module clock is turned off.

### 35.5.4 DMA

The DMA request lines are connected to the [DMA Controller \(DMAC\)](#). Using the QSPI DMA requests requires the DMA Controller to be configured first.

**Note:** DMAC write access must be 32-bit aligned. If a single byte is to be written in a 32-bit word, the rest of the word must be filled with 'ones'.

### 35.5.5 Debug Operation

When the CPU is halted in debug mode the QSPI continues normal operation. If the QSPI is configured in a way that requires it to be periodically serviced by the CPU through interrupts or similar, improper operation or data loss may result during debugging.

### 35.5.6 Register Access Protection

All registers with write-access are optionally write-protected by the [Peripheral Access Controller \(PAC\)](#), except the following registers:

- The Control A (CTRLA) register
- The Transmit Data (TXDATA) register
- The Interrupt Flag Status and Clear (INTFLAG) register
- The Interrupt Flag Status and Clear (INTFLAG) register

PAC write-protection is denoted by the 'PAC Write-Protection' property in the register description. Write-protection does not apply to accesses through an external debugger.

## 35.6 Functional Description

### 35.6.1 Principle of Operation

The QSPI is a high-speed synchronous data transfer interface. It allows high-speed communication between the device and peripheral or serial memory devices.

The QSPI operates as a host. It initiates and controls all data transactions.

When transmitting, the TXDATA register can be loaded with the next character to be transmitted during the current transmission.

When receiving, the data is transferred to the RXDATA register, and the receiver is ready for a new character.

### 35.6.2 Basic Operation

#### 35.6.2.1 Initialization

After Power-On Reset, this peripheral is enabled.

#### 35.6.2.2 Enabling, Disabling, and Resetting

The peripheral is enabled by writing a '1' to the Enable bit in the Control A register (CTRLA.ENABLE).

The peripheral is disabled by writing a '0' to CTRLA.ENABLE.

The peripheral is reset by writing a '1' to the Software Reset bit (CTRLA.SWRST).

### 35.6.3 Transfer Data Rate

By default, the QSPI module is enabled in single data rate (SDR) mode. In this operating mode, the CLK\_QSPI2X\_AHB clock is not used and can be disabled.

The Dual Data Rate (DDR) operating mode (read only) is enabled by writing a '1' to the Double Data Rate Enable bit in the Instruction Frame register (INSTRFRAME.DDREN). This operating mode requires the CLK\_QSPI2X\_AHB clock and must be enabled before writing the DDREN bit.

### 35.6.4 Serial Clock Baudrate

The QSPI Baud rate clock is generated by dividing the module clock (CLK\_QSPI\_AHB) by a value between 1 and 255.

This allows a maximum operating baud rate at up to Host Clock and a minimum operating baud rate of CLK\_QSPI\_AHB divided by 256.

### 35.6.5 Serial Clock Phase and Polarity

Four combinations of polarity and phase are available for data transfers. Writing the Clock Polarity bit in the QSPI Baud register (BAUD.CPOL) selects the polarity. The Clock Phase bit in the BAUD register programs the clock phase (BAUD.CPHA). These two parameters determine the edges of the clock signal on which data is driven and sampled. Each of the two parameters has two possible states, resulting in four possible combinations.

**Note:** The polarity/phase combinations are incompatible. Thus, the interfaced Client must use the same parameter values to communicate.

All combinations of polarity and phase are available when QSPI operates in SPI mode (CTRLB.MODE = 0).

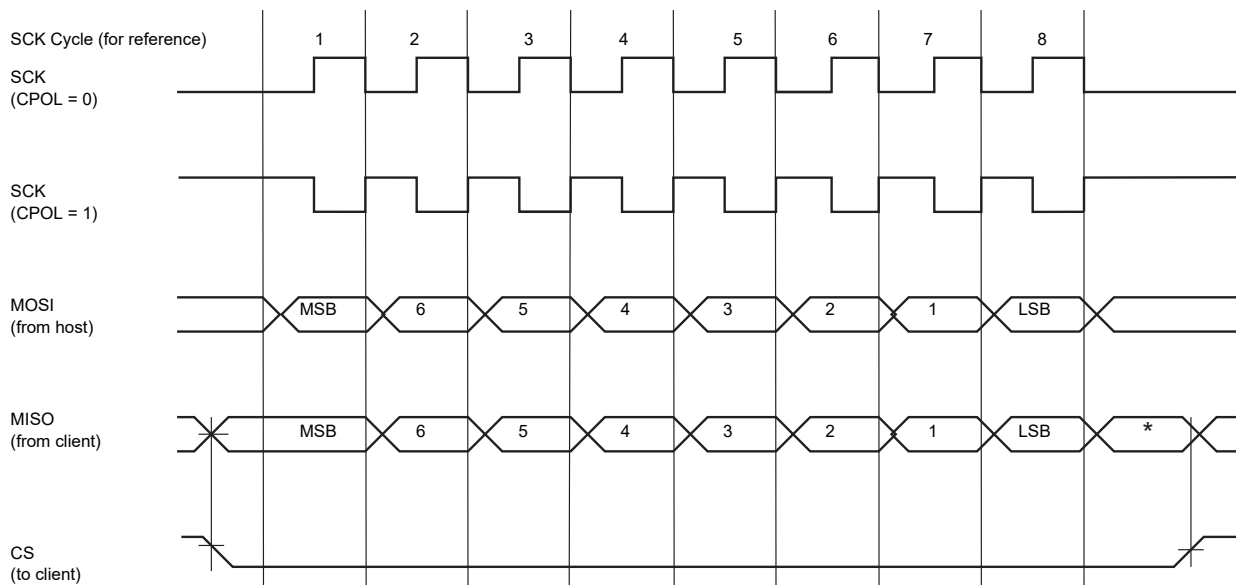
In QSPI Serial Memory mode (CTRLB.MODE = 1), only Mode 0 is supported.

In QSPI Dual Data Rate transfer mode (INSTRFRAME.DDREN = 1), only Mode 0 is supported.

**Table 35-2.** QSPI Transfer Mode

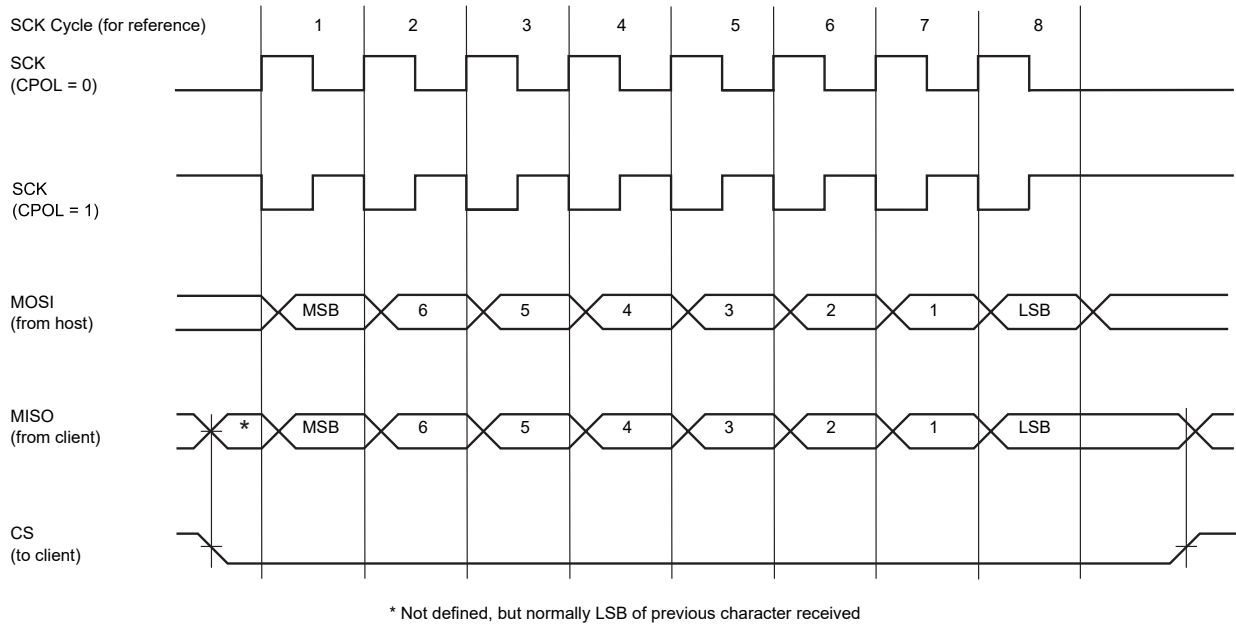
Mode	BAUD.CPOL	BAUD.CPHA	Shift SCK Edge	Capture SCK Edge	SCK Inactive Level
0	0	0	Falling	Falling	Low
1	0	1	Rising	Rising	Low
2	1	0	Rising	Rising	High
3	1	1	Falling	Falling	High

**Figure 35-3.** QSPI Transfer Modes (BAUD.CPHA = 0, 8-bit transfer)



\* Not defined, but normally MSB of previous character received

**Figure 35-4.** QSPI Transfer Modes (BAUD.CPHA = 1, 8-bit transfer)



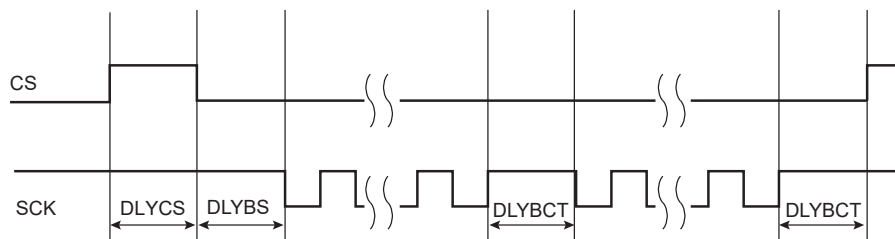
### 35.6.6 Transfer Delays

The QSPI supports several consecutive transfers while the chip select is active. Three delays can be programmed to modify the transfer waveforms:

- The delay between the inactivation and the activation of CS is programmed by writing the Minimum Inactive CS Delay bit field in the Control B register (CTRLB.DLYCS), allowing to tune the minimum time of CS at high level.
- The delay between consecutive transfers is programmed by writing the Delay Between Consecutive Transfers bit field in the Control B register (CTRLB.DLYBCT), allowing to insert a delay between two consecutive transfers. In Serial Memory mode, this delay is not programmable and DLYBCT settings are ignored.
- The delay before SCK is programmed by writing the Delay Before SCK bit field in the BAUD register (BAUD.DLYBS), allowing to delay the start of SPCK after the chip select has been asserted.

These delays allow the QSPI to be adapted to the interfaced peripherals and their speed and bus release time.

**Figure 35-5.** Programmable Delay



### 35.6.7 QSPI SPI Mode

In this mode, the QSPI acts as a regular SPI Host.

To activate this mode, the MODE bit in Control B register must be cleared (CTRLB.MODE=0).

### 35.6.7.1 SPI Mode Operations

The QSPI in standard SPI mode operates on the clock generated by the internal programmable baud rate generator. It fully controls the data transfers to and from the Client connected to the SPI bus. The QSPI drives the chip select line to the Client (CS) and the serial clock signal (SCK).

The QSPI features a single internal shift register and two holding registers: the Transmit Data Register (TXDATA) and the Receive Data Register (RXDATA). The holding registers maintain the data flow at a constant rate.

After enabling the QSPI, a data transfer begins when the processor writes to the TXDATA. The written data is immediately transferred into the internal shift register and transfer on the SPI bus starts. While the data in the internal shift register is shifted on the MOSI line, the MISO line is sampled and shifted into the internal shift register. Receiving data cannot occur without transmitting data.

If new data is written in TXDATA during the transfer, it stays in TXDATA until the current transfer is completed. Then, the received data is transferred from the internal shift register to the RXDATA, the data in TXDATA is loaded into the internal shift register, and a new transfer starts.

The transfer of data written in TXDATA in the internal shift register is indicated by the Transmit Data Register Empty (DRE) bit in the Interrupt Flag Status and Clear register (INTFLAG.DRE). When new data is written in TXDATA, this bit is cleared. The DRE bit is used to trigger the Transmit DMA channel.

The end of transfer is indicated by the Transmission Complete flag (INTFLAG.TXC). If the transfer delay for the last transfer was configured to be greater than 0 (CTRLB.DLYBCT), TXC is set after the completion of the delay. The module clock (CLK\_QSPI\_AHB) can be switched off at this time.

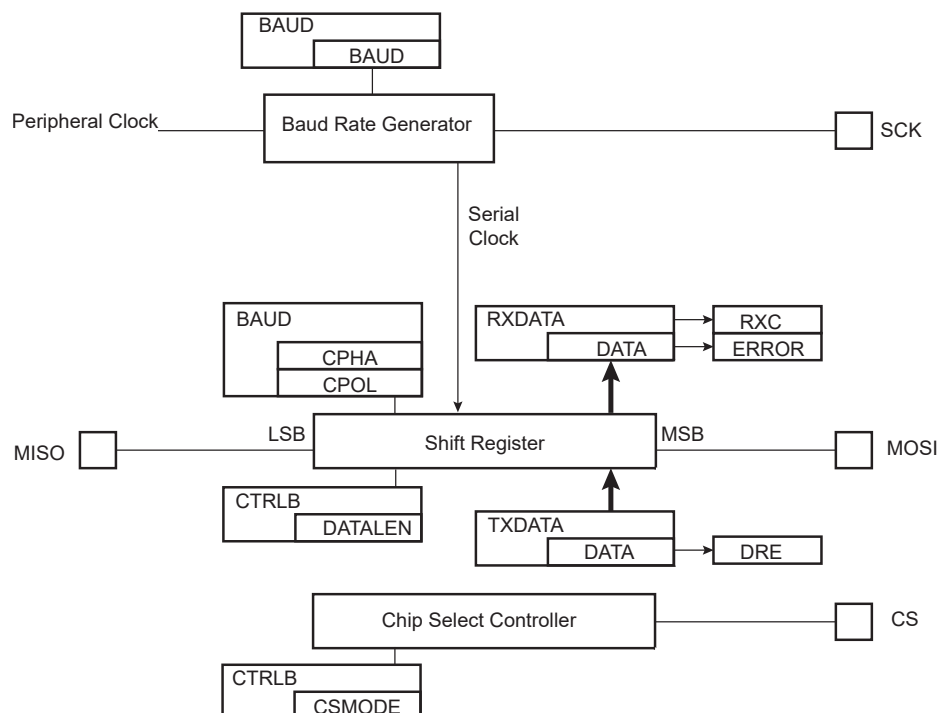
Ongoing transfer of received data from the internal shift register into RXDATA is indicated by the Receive Data Register Full flag (INTFLAG.RXC). When the received data is read, the RXC bit is cleared.

If the RXDATA has not been read before new data is received, the Overrun Error flag in INTFLAG register (INTFLAG.ERROR) is set. As long as this flag is set, data is loaded in RXDATA.

The SPI Mode [Block Diagram](#) shows a flow chart describing how transfers are handled.

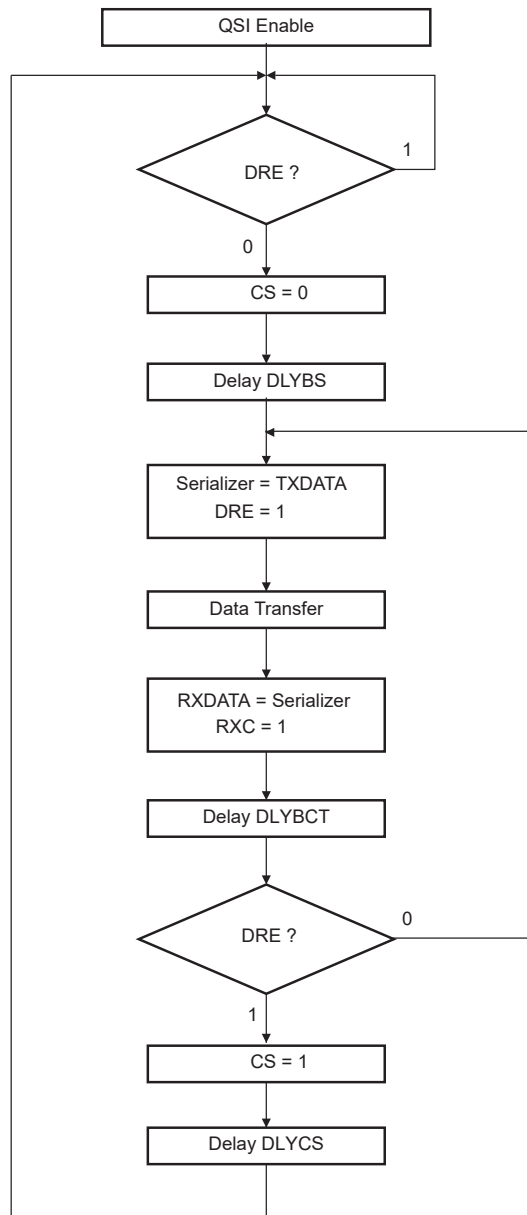
### 35.6.7.2 SPI Mode Block Diagram

Figure 35-6. SPI Mode Block Diagram

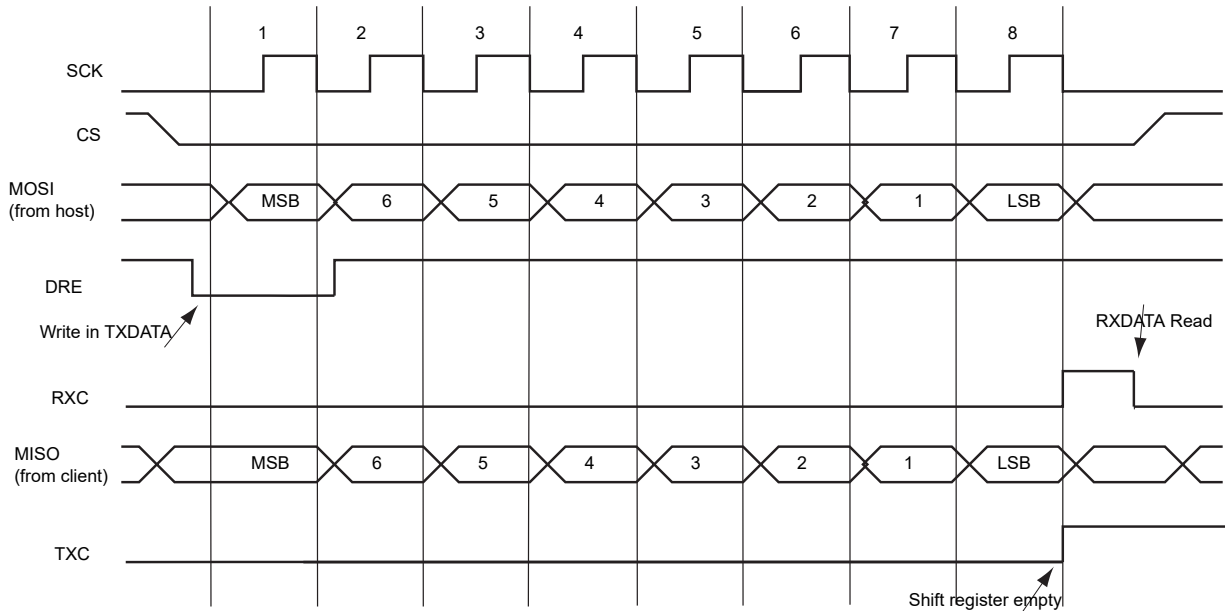


### 35.6.7.3 SPI Mode Flow Diagram

Figure 35-7. SPI Mode Flow Diagram



**Figure 35-8. Interrupt Flags Behaviour**



#### 35.6.7.4 Peripheral Deselection with DMA

When the Direct Memory Access Controller is used, the Chip Select line will remain low during the whole transfer since the Transmit Data Register Empty flag in the Interrupt Flag Status and Clear register (INTFLAG.DRE) is managed by the DMA itself. The reloading of the TXDATA by the DMA is done as soon as INTFLAG.DRE flag is set. In this case, setting the Chip Select Mode bit field in the Control B register (CTRLB.CSMODE) to 0x1 is not mandatory.

However, it may happen that when other DMA channels connected to other peripherals are in use as well, the QSPI DMA could be delayed by another DMA transfer with a higher priority on the bus. Having DMA buffers in slower memories like flash memory or SDRAM (compared to fast internal SRAM), may lengthen the reload time of the TXDATA by the DMA as well. This means that TXDATA might not be reloaded in time to keep the Chip Select line low. In this case the Chip Select line may toggle between data transfer and according to some SPI Client devices, and the communication might get lost. Writing CTRLB.CSMODE=0x1 can prevent this loss.

When CTRLB.CSMODE=0x0, the CS does not rise in all cases between two transfers on the same peripheral. During a transfer on a Chip Select, the INTFLAG.DRE flag is raised as soon as the content of the TXDATA is transferred into the internal shifter. When this flag is detected the TXDATA can be reloaded. If this reload occurs before the end of the current transfer and if the next transfer is performed on the same Chip Select as the current transfer, the Chip Select is not de-asserted between the two transfers. This may lead to difficulties for interfacing with some serial peripherals requiring the Chip Select to be de-asserted after each transfer. To facilitate interfacing with such devices, it is recommended to write CTRLB.CSMODE to 0x2.

#### 35.6.7.5 Peripheral Deselection without DMA

During multiple data transfers on a Chip Select without the DMA, the TXDATA is loaded by the processor, and the Transmit Data Register Empty flag in the Interrupt Flag Status and Clear register (INTFLAG.DRE) rises as soon as the content of the RXDATA is transferred into the internal shift register. When this flag is detected high, the TXDATA can be reloaded. If this reload-by-processor occurs before the end of the current transfer and if the next transfer is performed on the same Chip Select as the current transfer, the Chip Select is not de-asserted between the two transfers.

Depending on the application software handling the flags or servicing other interrupts or other tasks, the processor may not reload the TXDATA in time to keep the Chip Select active (low). A null



Delay Between Consecutive Transfer bit field value in the CTRLB register (CTRLB.DLYBCT) will give even less time for the processor to reload the TXDATA. With some SPI Client peripherals, requiring the Chip Select line to remain active (low) during a full set of transfers might lead to communication errors.

To facilitate interfacing with such devices, the Chip Select Mode bit field in the CTRLB register (CTRLB.CSMODE) can be written to 0x1. This allows the Chip Select lines to remain in their current state (low = active) until the end of transfer is indicated by the Last Transfer bit in the CTRLA register (CTRLA.LASTXFER). Even if the TXDATA is not reloaded the Chip Select will remain active. To have the Chip Select line rise at the end of the last data transfer, the LASTXFER bit in the CTRLA must be set before writing the last data to transmit into the TXDATA.

### 35.6.8 QSPI Serial Memory Mode

In this mode the QSPI acts as a serial Flash memory controller. The QSPI can be used to read data from the serial Flash memory allowing the CPU to execute code from it (XIP execute in place). The QSPI can also be used to control the serial Flash memory (Program, Erase, Lock, etc.) by sending specific commands. In this mode, the QSPI is compatible with single-bit SPI, Dual-SPI and Quad-SPI protocols.

To activate this mode, the MODE bit in Control B register must be set to one (CTRLB.MODE = 1).

In serial memory mode, data cannot be transferred by the TXDATA and the RXDATA, but by writing or reading the QSPI memory space (0x0400 0000 – 0x0500 0000).



**Important:** QSPI memory space region can be cached to improve data transfer speed. However, external Flash devices which have command/status registers mapped in the QSPI memory space region must be managed carefully by applying any one of the following configurations:

- Data cache must be disabled
- If data cache is required, then cache line must be invalidated before reading the status register

#### 35.6.8.1 Instruction Frame

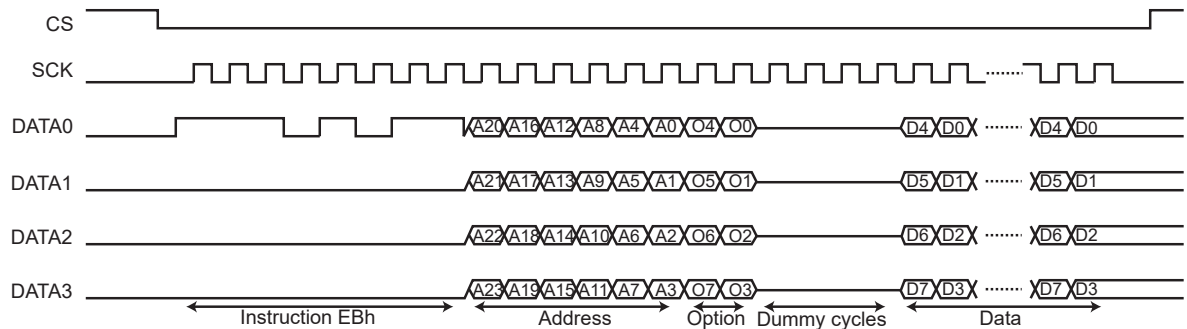
In order to control serial flash memories, the QSPI is able to sent instructions by the SPI bus (ex: READ, PROGRAM, ERASE, LOCK, etc.). Because instruction set implemented in serial flash memories is memory vendor dependant, the QSPI includes a complete instruction registers, which makes it very flexible and compatible with all serial flash memories.

An instruction frame includes:

- An instruction code (size: 8 bits). The instruction can be optional in some cases.
- An address (size: 24 bits or 32 bits). The address is optional but is required by instructions such as READ, PROGRAM, ERASE, LOCK. By default the address is 24 bits long, but it can be 32 bits long to support serial flash memories larger than 128 Mbit (16 Mbyte).
- An option code (size: 1/2/4/8 bits). The option code is optional but is useful for activate the “XIP mode” or the “Continuous Read Mode” for READ instructions, in some serial flash memory devices. These modes allow to improve the data read latency.
- Dummy cycles. Dummy cycles are optional but required by some READ instructions.
- Data bytes are optional. Data bytes are present for data transfer instructions such as READ or PROGRAM.

The instruction code, the address/option and the data can be sent with Single-bit SPI, Dual SPI or Quad SPI protocols.

**Figure 35-9. Instruction Frame**



### 35.6.8.2 Instruction Frame Sending

To send an instruction frame, the user must first configure the address to send by writing the field ADDR in the Instruction Address Register (INSTRADDR.ADDR). This step is required if the instruction frame includes an address and no data. When data is present, the address of the instruction is defined by the address of the data accesses in the QSPI memory space, and not by the INSTRADDR register.

If the instruction frame includes the instruction code and/or the option code, the user must configure the instruction code and/or the option code to send by writing the fields INST and OPTCODE bit fields in the Instruction Control Register (INSTRCTRL.OPTCODE, INSTRCTRL.INSTR).

Then, the user must write the Instruction Frame Register (INSTRFRAME) to configure the instruction frame depending on which instruction must be sent. If the instruction frame does not include data, writing in this register triggers the send of the instruction frame in the QSPI. If the instruction frame includes data, the send of the instruction frame is triggered by the first data access in the QSPI memory space.

The instruction frame is configured by the following bits and fields of INSTRFRAME:

- WIDTH field is used to configure which data lanes are used to send the instruction code, the address, the option code and to transfer the data. It is possible to use two unidirectional data lanes (MISO-MOSI Single-bit SPI), two bidirectional data lanes (DATA0 - DATA1 Dual SPI) or four bidirectional data lanes (DATA0 - DATA3).

**Table 35-3. WIDTH Encoding**

INSTRFRAME	Instruction	Address/Option	Data
0	Single-bit SPI	Single-bit SPI	Single-bit SPI
1	Single-bit SPI	Single-bit SPI	Dual SPI
2	Single-bit SPI	Single-bit SPI	Quad SPI
3	Single-bit SPI	Dual SPI	Dual SPI
4	Single-bit SPI	Quad SPI	Quad SPI
5	Dual SPI	Dual SPI	Dual SPI
6	Quad SPI	Quad SPI	Quad SPI
7	Reserved		

- INSTREN bit enables sending an instruction code.
- ADDRLEN bit enables sending of an address after the instruction code.
- OPTCODEEN bit enables sending of an option code after the address.
- DATAEN bit enables the transfer of data (READ or PROGRAM instruction).
- OPTCODELEN field configures the option code length (0 -> 1-bit / 1 -> 2-bit / 2 -> 4-bit / 3 -> 8-bit). The value written in OPTCODELEN must be consistent with value written in the field WIDTH. For

example: OPTCODELEN = 0 (1-bit option code) is not coherent with WIDTH = 6 (option code sent with QuadSPI protocol, thus the minimum length of the option code is 4-bit).

- ADDRLEN bit configures the address length (0 -> 24 bits / 1-> 32 bits)
- TFRTYPE field defines which type of data transfer must be performed.
- DUMMYLEN field configures the number of dummy cycles when reading data from the serial flash memory. Between the address/option and the data, with some instructions, dummy cycles are inserted by the serial flash memory.

If data transfer is enabled, the user can access the serial memory by reading or writing the QSPI memory space following these rules:

- Reading from the serial memory, but not memory data (for example reading the JEDEC-ID or the STATUS), requires TFRTYPE to be written to 0x0.
- Reading from the serial memory, and particularly memory data, requires TFRTYPE to be written to '1'.
- Writing to the serial memory, but not memory data (for example writing the configuration or STATUS), requires TFRTYPE to be written to 0x2.
- Writing to the serial memory, and particularly memory data, requires TFRTYPE to be written to 0x3.

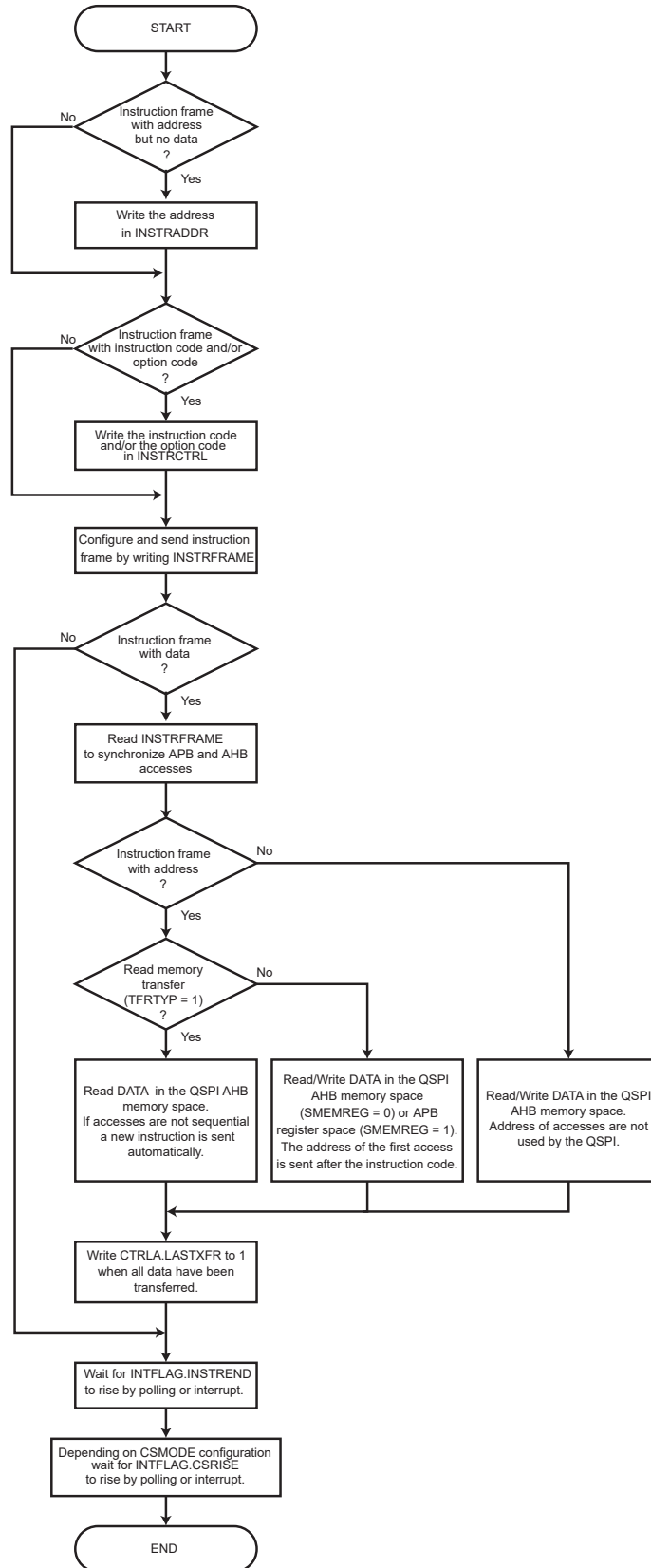
If TFRTYPE has a value other than 0x1 and CTRLB.SMEMREG=0, the address sent in the instruction frame is the address of the first system bus accesses. The addresses of the subsequent access actions are not used by the QSPI. At each system bus access, an SPI transfer is performed with the same size. For example, a half-word system bus access leads to a 16-bit SPI transfer, and a byte system bus access leads to an 8-bit SPI transfer.

If CTRLB.SMEMREG=1, accesses are made via the QSPI registers and the address sent in the instruction frame is the address defined in the INSTRADDR register. Each time the INSTRFRAME or TXDATA registers are written, an SPI transfer is performed with a byte size. Another byte is read each time RXDATA register is read or written each time TXDATA register is written. The SPI transfer ends by writing the LASTXFER bit in Control A register (CTRLA.LASTXFER).

If TFRTYPE=0x1, the address of the first instruction frame is the one of the first read access in the QSPI memory space. Each time the read accesses become non-sequential (addresses are not consecutive), a new instruction frame is sent with the last system bus access address. In this way, the system can read data at a random location in the serial memory. The size of the SPI transfers may differ from the size of the system bus read accesses.

When data transfer is not enabled, the end of the instruction frame is indicated when the INSTREND interrupt flag in the INTFLAG register is set. When data transfer is enabled, the user must indicate when data transfer is completed in the QSPI memory space by setting the bit LASTXFR in the CTRLA. The end of the instruction frame is indicated when the INSTREND interrupt flag in the INTFLAG register is set.

Figure 35-10. Instruction Transmission Flow Diagram



### 35.6.8.3 Read Memory Transfer

The user can access the data of the serial memory by sending an instruction with DATAEN=1 and TFRTYP=0x1 in the Instruction Frame register (INSTRFRAME).

In this mode the QSPI is able to read data at random address into the serial flash memory, allowing the CPU to execute code directly from it (XIP execute-in-place).

In order to fetch data, the user must first configure the instruction frame by writing the INSTRFRAME. Then data can be read at any address in the QSPI address space mapping. The address of the system bus read accesses match the address of the data inside the serial Flash memory.

When Fetch Mode is enabled, several instruction frames can be sent before writing the bit LASTXFR in the CTRLA. Each time the system bus read accesses become non-sequential (addresses are not consecutive), a new instruction frame is sent with the corresponding address.

### 35.6.8.4 Continuous Read Mode

The QSPI is compatible with Continuous Read Mode (CRM) which is implemented in some Serial Flash memories.

The CRM allows to reduce the instruction overhead by excluding the instruction code from the instruction frame. When CRM is activated in a Serial Flash memory (by a specific option code), the instruction code is stored in the memory. For the next instruction frames, the instruction code is not required, as the memory uses the stored one.

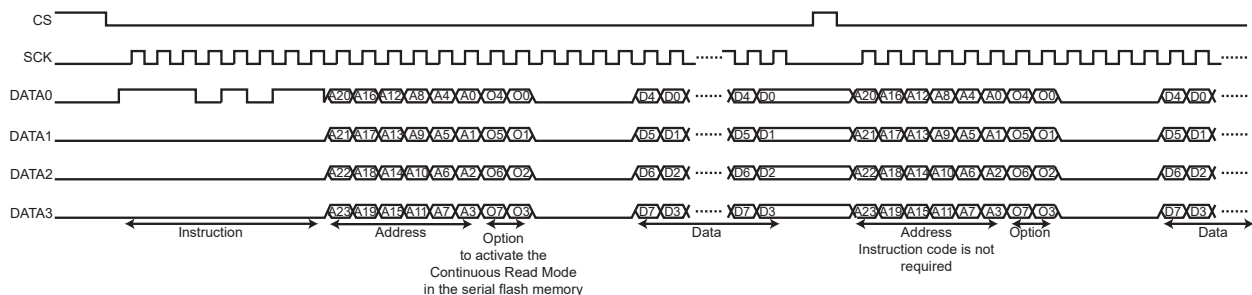
In the QSPI, CRM is used when reading data from the memory (INSTRFRAME.TFRTYPE=0x1). The addresses of the system bus read accesses are often non-sequential, this leads to many instruction frames with always the same instruction code. By disabling the sending of the instruction code, the CRM reduces the access time of the data.

To be functional, this mode must be enabled in both the QSPI and the Serial Flash memory. The CRM is enabled in the QSPI by setting the CRM bit in the INSTRFRAME register (INSTRFRAME.CRMODE=1, INSTRFRAME.TFRTYPE must be 0x1). The CRM is enabled in the Serial Flash memory by sending a specific option code.



If CRM is not supported by the Serial Flash memory or disabled, the CRMODE bit must not be set. Otherwise, data read out the Serial Flash memory is not valid.

Figure 35-11. Continuous Read Mode



### 35.6.8.5 Instruction Frame Transmission Examples

All waveforms in the following examples describe SPI transfers in SPI Clock mode 0 (BAUD.CPOL=0 and BAUD.CPHA=0). All system bus accesses described below refer to the system bus address phase. System bus wait cycles and system bus data phases are not shown.

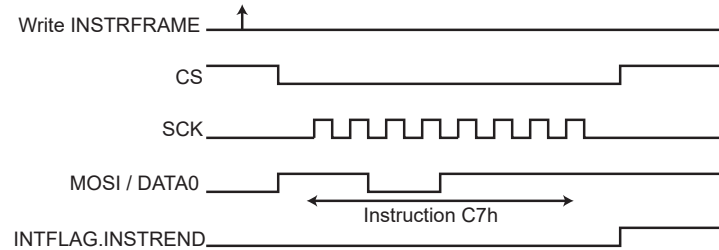
**Example 35-1.** Example 1

Instruction in Single-bit SPI, without address, without option, without data.

Command: CHIP ERASE (C7h).

- Write 0x0000\_00C7 to INSTRCTRL register.
- Write 0x0000\_0010 to INSTRFRAME register.
- Wait for INTFLAG.INSTREND to rise.

**Figure 35-12.** Instruction Transmission Waveform 1



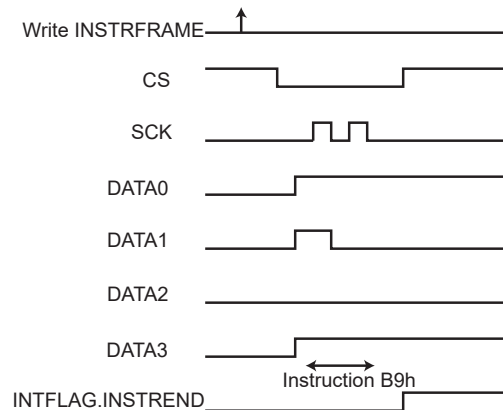
**Example 35-2.** Example 2

Instruction in Quad SPI, without address, without option, without data.

Command: POWER DOWN (B9h)

- Write 0x0000\_00B9 to INSTRCTRL register.
- Write 0x0000\_0016 to INSTRFRAME register.
- Wait for INTFLAG.INSTREND to rise.

**Figure 35-13.** Instruction Transmission Waveform 2



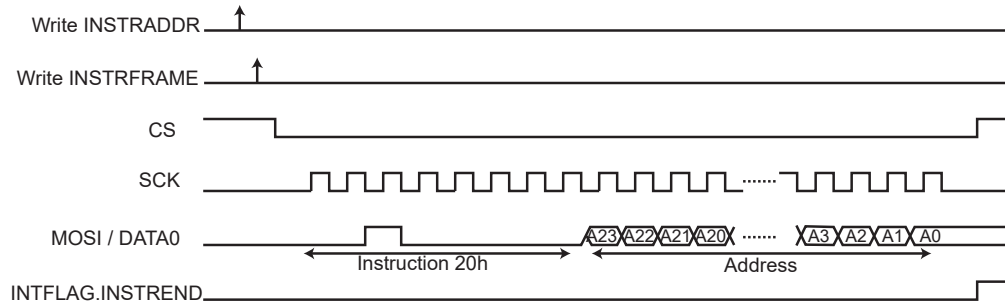
**Example 35-3.** Example 3

Instruction in Single-bit SPI, with address in Single-bit SPI, without option, without data.

Command: BLOCK ERASE (20h)

- Write the address (of the block to erase) to QSPI\_AR.
- Write 0x0000\_0020 to INSTRCTRL register.
- Write 0x0000\_0030 to INSTRFRAME register.
- Wait for INTFLAG.INSTREND to rise.

**Figure 35-14.** Instruction Transmission Waveform 3



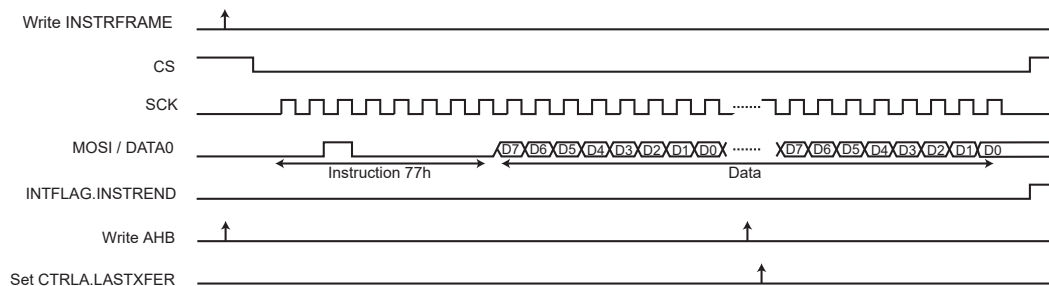
**Example 35-4.** Example 4

Instruction in Single-bit SPI, without address, without option, with data write in Single-bit SPI.

Command: SET BURST (77h)

- Write 0x0000\_0077 to INSTRCTRL register.
- Write 0x0000\_2090 to INSTRFRAME register.
- Read INSTRFRAME register (dummy read) to synchronize system bus accesses.
- Write data to the system bus memory space (0x0400\_0000–0x0500\_0000). The address of the system bus write accesses is not used.
- Write the LASTXFR bit in CTRLA register to '1'.
- Wait for INTFLAG.INSTREND to rise.

**Figure 35-15.** Instruction Transmission Waveform 4



**Example 35-5.** Example 5

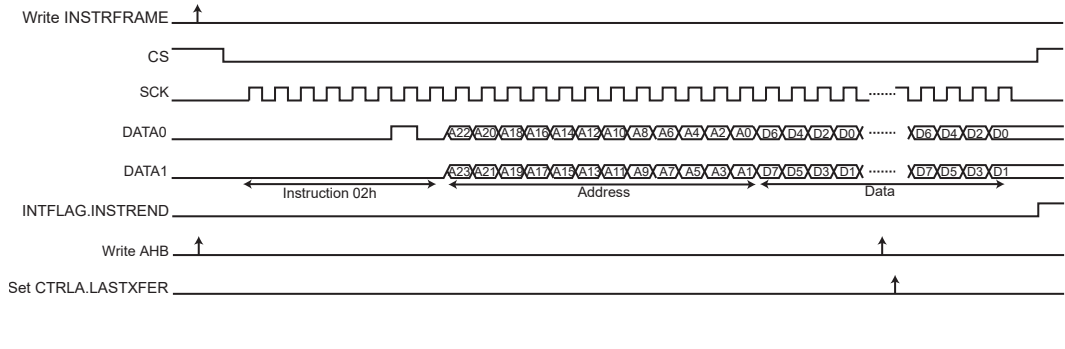
Instruction in Single-bit SPI, with address in Dual SPI, without option, with data write in Dual SPI.

Command: BYTE/PAGE PROGRAM (02h)

- Write 0x0000\_0002 to INSTRCTRL register.
- Write 0x0000\_30B3 to INSTRFRAME register.
- Read INSTRFRAME register (dummy read) to synchronize system bus accesses.
- Write data to the QSPI system bus memory space (0x040 00000–0x0500\_0000). The address of the first system bus write access is sent in the instruction frame. The address of the next system bus write accesses is not used.

- Write LASTXFR bit in CTRLA register to '1'.
- Wait for INTFLAG.INSTREND to rise.

**Figure 35-16.** Instruction Transmission Waveform 5



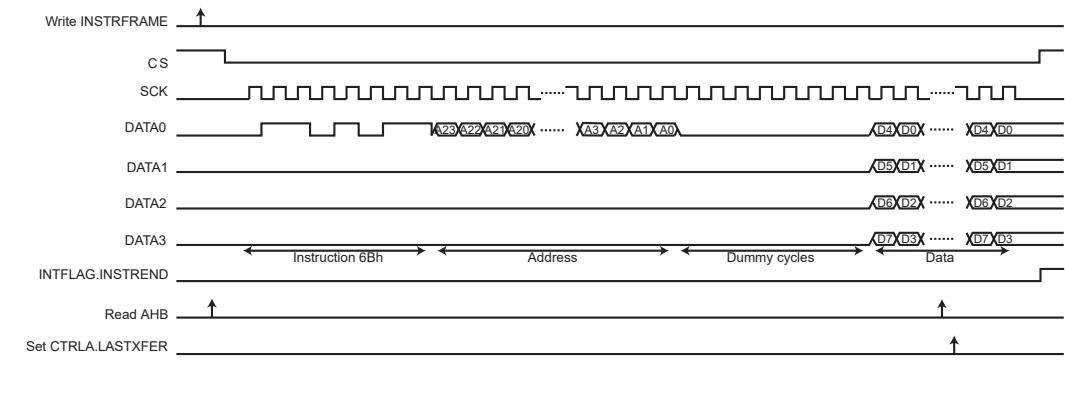
**Example 35-6.** Example 6

Instruction in Single-bit SPI, with address in Single-bit SPI, without option, with data read in Quad SPI, with eight dummy cycles.

Command: QUAD\_OUTPUT READ ARRAY (6Bh)

- Write 0x0000\_006B to INSTRCTRL register.
- Write 0x0008\_10B2 to INSTRFRAME register.
- Read QSPI\_IR (dummy read) to synchronize system bus accesses.
- Read data from the QSPI system bus memory space (0x040\_00000–0x0500\_0000). The address of the first system bus read access is sent in the instruction frame. The address of the next system bus read accesses is not used.
- Write the LASTXFR bit in CTRLA register to '1'.
- Wait for INTFLAG.INSTREND to rise.

**Figure 35-17.** Instruction Transmission Waveform 6



**Example 35-7.** Example 7

Instruction in Single-bit SPI, with address and option in Quad SPI, with data read from Quad SPI, with four dummy cycles, with fetch and continuous read.

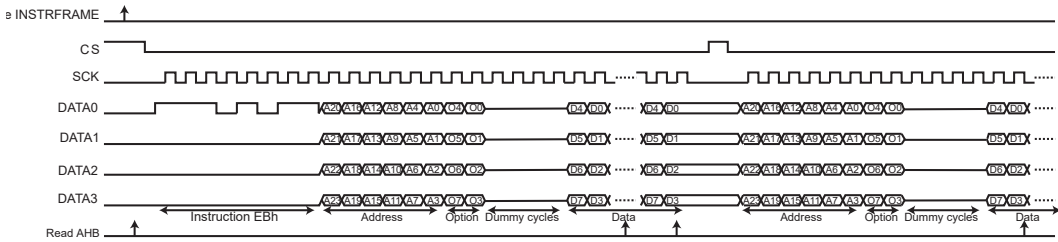
Command: FAST READ QUAD I/O (EBh) - 8-BIT OPTION (0x30h)

- Write 0x0030\_00EB to INSTRCTRL register.



- Write 0x0004\_33F4 to INSTRFRAME register.
- Read INSTRFRAME register (dummy read) to synchronize system bus accesses.
- Read data from the QSPI system bus memory space (0x040\_00000–0x0500\_0000). Fetch is enabled, the address of the system bus read accesses is always used.
- Write LASTXFR bit in CTRLA register to '1'.
- Wait for INTFLAG.INSTREND to rise.

**Figure 35-18.** Instruction Transmission Waveform 7



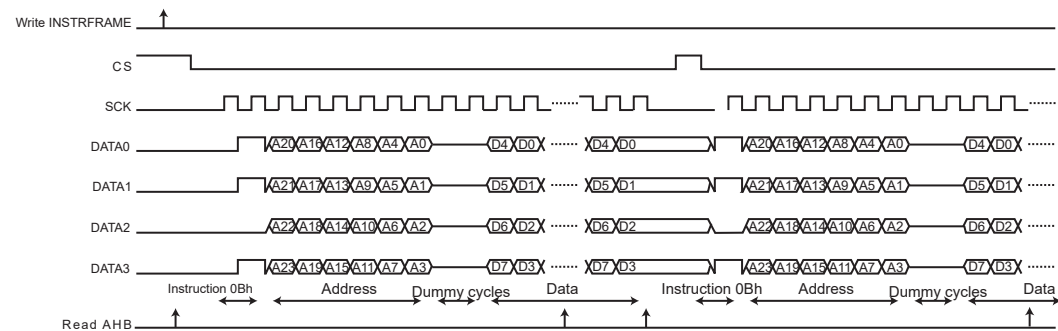
**Example 35-8.** Example 8

Instruction in Quad SPI, with address in Quad SPI, without option, with data read from Quad SPI, with two dummy cycles, with fetch.

Command: HIGH-SPEED READ (0Bh)

- Write 0x0000\_000B to INSTRCTRL register.
- Write 0x0002\_20B6 to INSTRFRAME register.
- Read INSTRFRAME register (dummy read) to synchronize system bus accesses.
- Read data in the QSPI system bus memory space (0x040\_00000–0x0500\_0000). Fetch is enabled, the address of the system bus read accesses is always used.
- Write LASTXFR bit in CTRLA register to '1'.
- Wait for INTFLAG.INSTREND to rise.

**Figure 35-19.** Instruction Transmission Waveform 8



**35.6.9 Scrambling/Unscrambling Function**

The scrambling/unscrambling function cannot be performed on devices other than memories. Data is scrambled when written to memory and unscrambled when data is read.

The external data lines can be scrambled in order to prevent intellectual property data located in off-chip memories from being easily recovered by analyzing data at the package pin level of either the micro-controller or the QSPI Client device (e.g. memory).

The scrambling/unscrambling function can be enabled by writing a '1' to the ENABLE bit in the Scrambling Control register (SCRAMBCTRL.ENABLE).

The scrambling and unscrambling are performed on-the-fly without impacting the throughput.

The scrambling method depends on the user-configurable Scrambling User Key in the Scrambling Key register (SCRAMBKEY.KEY). This register is only accessible in write mode.

By default, the scrambling and unscrambling algorithm includes the scrambling user key, plus a device-dependent random value. This random value is not included when the Scrambling/Unscrambling Random Value Disable bit in the Scrambling Mode register (SCRAMBCTRL.RANDOMDIS) is written to '1'.

The random value is neither user configurable nor readable. If SCRAMBCTRL.RANDOMDIS=0, data scrambled by a given circuit cannot be unscrambled by a different circuit.

If SCRAMBCTRL.RANDOMDIS=1, the scrambling/unscrambling algorithm includes only the scrambling user key, making it possible to manage data by different circuits. Note that the same key must be used by the different circuits.

The scrambling user key must be securely stored in a reliable non-volatile memory in order to recover data from the off-chip memory. Any data scrambled with a given key cannot be recovered if the key is lost.

### 35.6.10 DMA Operation

The QSPI generates the following DMA requests:

- Data received (RX): The request is set when data is available in the RXDATA register, and cleared when RXDATA is read.
- Data transmit (TX): The request is set when the transmit buffer (TXDATA) is empty, and cleared when TXDATA is written.

**Note:** If DMA and RX memory modes are selected, a QSPI memory space read operation is required to force the first triggering.

If the CPU accesses the registers which are source of DMA request set/clear condition, the DMA request can be lost or the DMA transfer can be corrupted.

### 35.6.11 Interrupts

The QSPI has the following interrupt source:

- Interrupt Request (INTREQ): Indicates that at least one bit in the Interrupt Flag Status and Clear register (INTFLAG) is set to '1'.

Each interrupt source has an interrupt flag associated with it. The interrupt flag in the Interrupt Flag Status and Clear (INTFLAG) register is set when the interrupt condition occurs. Each interrupt can be individually enabled by writing a '1' to the corresponding bit in the Interrupt Enable Set (INTENSET) register, and disabled by writing a '1' to the corresponding bit in the Interrupt Enable Clear (INTENCLR) register. An interrupt request is generated when the interrupt flag is set and the corresponding interrupt is enabled. The interrupt request remains active until the interrupt flag is cleared, the interrupt is disabled, or the QSPI is reset. All interrupt requests from the peripheral are ORed together on system level to generate one combined interrupt request to the [NVIC](#). The user must read the INTFLAG register to determine which interrupt condition is present.

Note that interrupts must be globally enabled for interrupt requests to be generated.

## 35.7 Register Summary

Offset	Name	Bit Pos.	7	6	5	4	3	2	1	0
0x00	CTRLA	7:0							ENABLE	SWRST
		15:8								
		23:16								
		31:24								LASTXFER
0x04	CTRLB	7:0			CSMODE[1:0]		SMEMREG	WDRBT	LOOPEN	MODE
		15:8							DATALEN[3:0]	
		23:16							DLYBCT[7:0]	
		31:24							DLYCS[7:0]	
0x08	BAUD	7:0							CPHA	CPOL
		15:8						BAUD[7:0]		
		23:16							DLYBS[7:0]	
		31:24								
0x0C	RXDATA	7:0								DATA[7:0]
		15:8								DATA[15:8]
		23:16								
		31:24								
0x10	TXDATA	7:0								DATA[7:0]
		15:8								DATA[15:8]
		23:16								
		31:24								
0x14	INTENCLR	7:0					ERROR	TXC	DRE	RXC
		15:8						INSTREND		CSRISE
		23:16								
		31:24								
0x18	INTENSET	7:0					ERROR	TXC	DRE	RXC
		15:8						INSTREND		CSRISE
		23:16								
		31:24								
0x1C	INTFLAG	7:0					ERROR	TXC	DRE	RXC
		15:8						INSTREND		CSRISE
		23:16								
		31:24								
0x20	STATUS	7:0							ENABLE	
		15:8							CSSTATUS	
		23:16								
		31:24								
0x24 ... 0x2F	Reserved									
0x30	INSTRADDR	7:0								ADDR[7:0]
		15:8								ADDR[15:8]
		23:16								ADDR[23:16]
		31:24								ADDR[31:24]
0x34	INSTRCTRL	7:0								INSTR[7:0]
		15:8								
		23:16								OPTCODE[7:0]
		31:24								
0x38	INSTRFRAME	7:0	DATAEN	OPTCODEEN	ADDREN	INSTREN				WIDTH[2:0]
		15:8	DDREN	CRMODE		TFRTYPE[1:0]			ADDRLN	OPTCODELEN[1:0]
		23:16								DUMMYLEN[4:0]
		31:24								
0x3C ... 0x3F	Reserved									
0x40	SCRAMBCTRL	7:0							RANDOMDIS	ENABLE
		15:8								
		23:16								
		31:24								

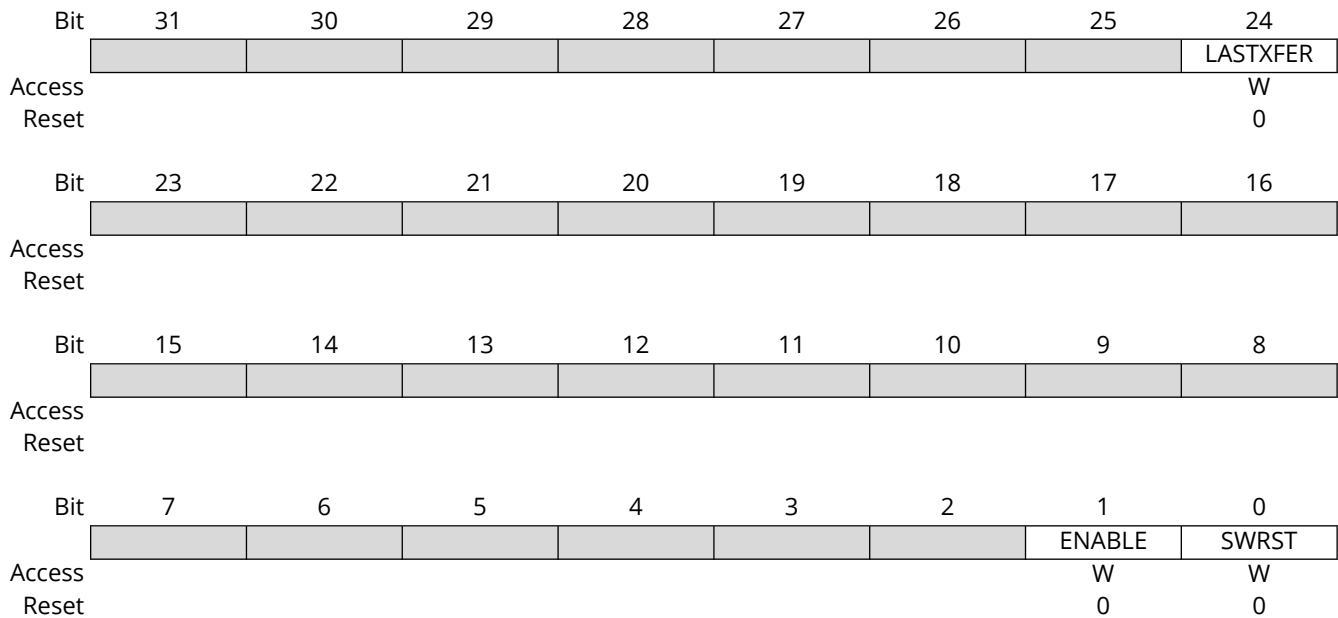
.....continued

Offset	Name	Bit Pos.	7	6	5	4	3	2	1	0	
0x44	SCRAMBKEY	7:0	KEY[7:0]								
		15:8	KEY[15:8]								
		23:16	KEY[23:16]								
		31:24	KEY[31:24]								

### 35.7.1 Control A

**Name:** CTRLA  
**Offset:** 0x00  
**Reset:** 0x00000000  
**Property:** -

Control A



#### Bit 24 – LASTXFER Last Transfer

0: No effect.

1: The chip select will be de-asserted after the character written in TD has been transferred.

#### Bit 1 – ENABLE Enable

Writing a '0' to this bit disables the QSPI.

Writing a '1' to this bit enables the QSPI to transfer and receive data.

As soon as ENABLE is reset, QSPI finishes its transfer.

All pins are set in input mode and no data is received or transmitted.

If a transfer is in progress, the transfer is finished before the QSPI is disable.

#### Bit 0 – SWRST Software Reset

Writing a '0' to this bit has no effect.

Writing a '1' to this bit resets the QSPI. A software-triggered hardware reset of the QSPI interface is performed.

DMAC channels are not affected by software reset.

### 35.7.2 Control B

**Name:** CTRLB  
**Offset:** 0x04  
**Reset:** 0x00000000  
**Property:** PAC Write-Protection

Control B

Bit	31	30	29	28	27	26	25	24
	DLYCS[7:0]							
Access	R/W	R/W	R/W	R/W	R/W	R/W	R/W	R/W
Reset	0	0	0	0	0	0	0	0
Bit	23	22	21	20	19	18	17	16
	DLYBCT[7:0]							
Access	R/W	R/W	R/W	R/W	R/W	R/W	R/W	R/W
Reset	0	0	0	0	0	0	0	0
Bit	15	14	13	12	11	10	9	8
					DATALEN[3:0]			
Access					R/W	R/W	R/W	R/W
Reset					0	0	0	0
Bit	7	6	5	4	3	2	1	0
			CSMODE[1:0]		SMEMREG	WDRBT	LOOPEN	MODE
Access			R/W	R/W	R/W	R/W	R/W	R/W
Reset			0	0	0	0	0	0

#### Bits 31:24 – DLYCS[7:0] Minimum Inactive CS Delay

This bit field defines the minimum delay between the inactivation and the activation of CS. The DLYCS time guarantees the Client minimum deselect time.

If DLYCS is 0x00, one CLK\_QSPI\_AHB period will be inserted by default.

Otherwise, the following equation determines the delay:

$$DLYCS = \text{Minimum inactive} \times f_{\text{peripheral clock}}$$

#### Bits 23:16 – DLYBCT[7:0] Delay Between Consecutive Transfers

This field defines the delay between two consecutive transfers with the same peripheral without removing the chip select. The delay is always inserted after each transfer and before removing the chip select if needed.

When DLYBCT=0x00, no delay between consecutive transfers is inserted and the clock keeps its duty cycle over the character transfers. In Serial Memory mode (MODE=1), DLYBCT is ignored and no delay is inserted. Otherwise, the following equation determines the delay:

$$DLYBCT = (\text{Delay Between Consecutive Transfers} \times f_{\text{peripheral clock}}) / 32$$

#### Bits 11:8 – DATALEN[3:0] Data Length

The DATALEN field determines the number of data bits transferred. Reserved values should not be used.

Value	Name	Description
0x0	8BITS	8-bits transfer
0x1	9BITS	9-bits transfer
0x2	10BITS	10-bits transfer
0x3	11BITS	11-bits transfer
0x4	12BITS	12-bits transfer
0x5	13BITS	13-bits transfer

Value	Name	Description
0x6	14BITS	14-bits transfer
0x7	15BITS	15-bits transfer
0x8	16BITS	16-bits transfer
0x9-0xF		Reserved

#### Bits 5:4 – CSMODE[1:0] Chip Select Mode

The CSMODE field determines how the chip select is de-asserted.

Value	Name	Description
0x0	NORELOAD	The chip select is de-asserted if TD has not been reloaded before the end of the current transfer.
0x1	LASTXFER	The chip select is de-asserted when the bit LASTXFER is written at 1 and the character written in TD has been transferred.
0x2	SYSTEMATICALLY	The chip select is de-asserted systematically after each transfer.
0x3		Reserved

#### Bit 3 – SMEMREG Serial Memory Register Mode

Value	Description
0	Serial memory registers are written via AHB access.
1	Serial memory registers are written via APB access. Reset the QSPI.

#### Bit 2 – WDRBT Wait Data Read Before Transfer

This bit determines the Wait Data Read Before Transfer option.

#### Bit 1 – LOOPEN Local Loopback Enable

This bit defines if the Local Loopback is enabled or disabled.

LOOPEN controls the local loopback on the data serializer for testing in SPI Mode only. (MISO is internally connected on MOSI).

Value	Description
0	Local Loopback is disabled.
1	Local Loopback is enabled.

#### Bit 0 – MODE Serial Memory Mode

This bit defines if the QSPI is in SPI Mode or Serial Memory Mode.

Value	Name	Description
0	SPI	SPI operating mode
1	MEMORY	Serial Memory operating mode

### 35.7.3 Baud Rate

**Name:** BAUD  
**Offset:** 0x08  
**Reset:** 0x00000000  
**Property:** PAC Write-Protection

Bit	31	30	29	28	27	26	25	24
Access								
Reset								
Bit	23	22	21	20	19	18	17	16
	DLYBS[7:0]							
Access	R/W	R/W	R/W	R/W	R/W	R/W	R/W	R/W
Reset	0	0	0	0	0	0	0	0
Bit	15	14	13	12	11	10	9	8
	BAUD[7:0]							
Access	R/W	R/W	R/W	R/W	R/W	R/W	R/W	R/W
Reset	0	0	0	0	0	0	0	0
Bit	7	6	5	4	3	2	1	0
							CPHA	CPOL
Access							R/W	R/W
Reset							0	0

#### Bits 23:16 – DLYBS[7:0] Delay Before SCK

This field defines the delay from CS valid to the first valid SCK transition. When DLYBS equals zero, the CS valid to SCK transition is 1/2 the SCK clock period. Otherwise, the following equation determines the delay:

**Equation 35-1.** Delay Before SCK

$$\text{Delay Before SCK} = \frac{DLYBS}{MCK}$$

#### Bits 15:8 – BAUD[7:0] Serial Clock Baud Rate

The QSPI uses a modulus counter to derive the SCK baud rate from the module clock CLK\_QSPI\_AHB. The Baud rate is selected by writing a value from 0 to 255 in the BAUD field. The following equation determines the SCK baud rate:

**Equation 35-2.** SCK Baud Rate

$$\text{SCK Baud Rate} = \frac{MCK}{(BAUD + 1)}$$

#### Bit 1 – CPHA Clock Phase

CPHA determines which edge of SCK causes data to change and which edge causes data to be captured. CPHA is used with CPOL to produce the required clock/data relationship between Host and Client devices.

Value	Description
0	Data is captured on the leading edge of SCK and changed on the following edge of SCK.
1	Data is changed on the leading edge of SCK and captured on the following edge of SCK.



**Bit 0 – CPOL** Clock Polarity

CPOL is used to determine the inactive state value of the serial clock (SCK). It is used with CPHA to produce the required clock/data relationship between Host and Client devices.

Value	Description
0	The inactive state value of SCK is logic level zero.
0	The inactive state value of SCK is logic level 'one'.

### 35.7.4 Receive Data

**Name:** RXDATA  
**Offset:** 0x0C  
**Reset:** 0x00000000  
**Property:** -

Bit	31	30	29	28	27	26	25	24
Access								
Reset								
Bit	23	22	21	20	19	18	17	16
Access								
Reset								
Bit	15	14	13	12	11	10	9	8
Access	DATA[15:8]							
Reset	0	0	0	0	0	0	0	0
Bit	7	6	5	4	3	2	1	0
Access	DATA[7:0]							
Reset	0	0	0	0	0	0	0	0

#### Bits 15:0 – DATA[15:0] Receive Data

Data received by the QSPI is stored in this register right-justified. Unused bits read zero.

### 35.7.5 Transmit Data

**Name:** TXDATA  
**Offset:** 0x10  
**Reset:** 0x00000000  
**Property:** -

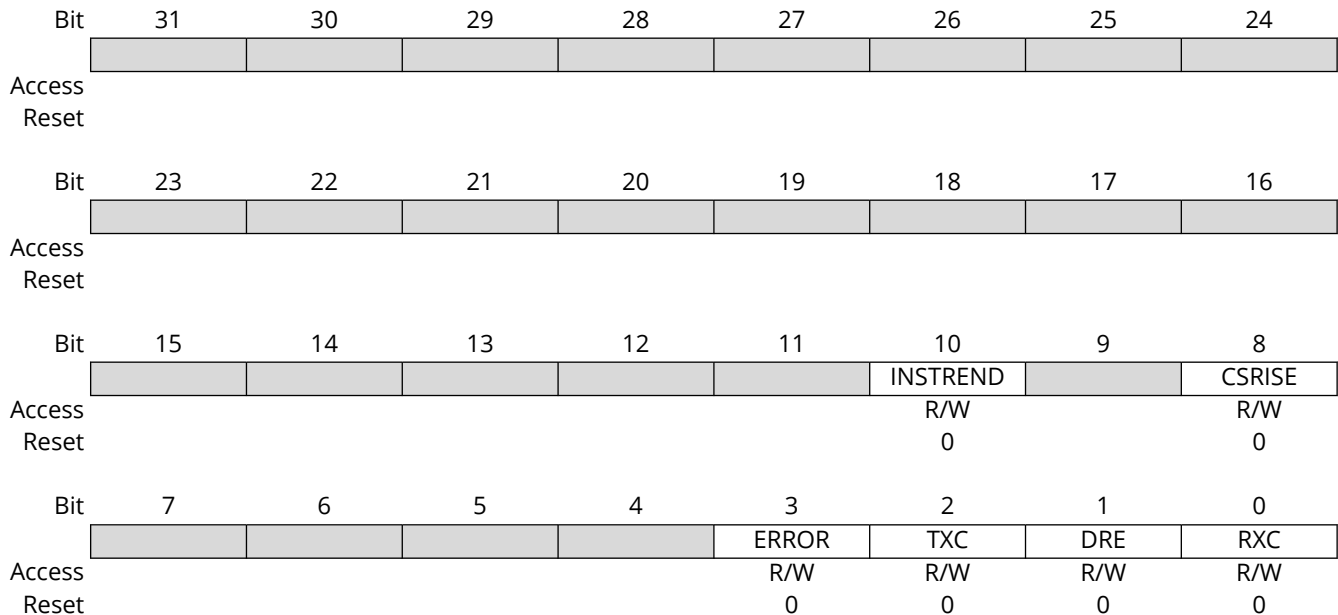
Bit	31	30	29	28	27	26	25	24
Access								
Reset								
Bit	23	22	21	20	19	18	17	16
Access								
Reset								
Bit	15	14	13	12	11	10	9	8
	DATA[15:8]							
Access	W	W	W	W	W	W	W	W
Reset	0	0	0	0	0	0	0	0
Bit	7	6	5	4	3	2	1	0
	DATA[7:0]							
Access	W	W	W	W	W	W	W	W
Reset	0	0	0	0	0	0	0	0

#### Bits 15:0 – DATA[15:0] Transmit Data

Data to be transmitted by the QSPI is stored in this register. Information to be transmitted must be written to the transmit data register in a right-justified format.

### 35.7.6 Interrupt Enable Clear

**Name:** INTENCLR  
**Offset:** 0x14  
**Reset:** 0x00000000  
**Property:** PAC Write-Protection



**Bit 10 – INSTREND** Instruction End Interrupt Disable  
 Writing a '0' to this bit has no effect.  
 Writing a '1' will clear the corresponding interrupt request.

Value	Description
0	The INSTREND interrupt is disabled.
1	The INSTREND interrupt is enabled.

**Bit 8 – CSRISE** Chip Select Rise Interrupt Disable  
 Writing a '0' to this bit has no effect.  
 Writing a '1' will clear the corresponding interrupt request.

Value	Description
0	The CSRISE interrupt is disabled.
1	The CSRISE interrupt is enabled.

**Bit 3 – ERROR** Overrun Error Interrupt Disable  
 Writing a '0' to this bit has no effect.  
 Writing a '1' will clear the corresponding interrupt request.

Value	Description
0	The ERROR interrupt is disabled.
1	The ERROR interrupt is enabled.

**Bit 2 – TXC** Transmission Complete Interrupt Disable  
 Writing a '0' to this bit has no effect.  
 Writing a '1' will clear the corresponding interrupt request.

Value	Description
0	The TXC interrupt is disabled.
1	The TXC interrupt is enabled.

**Bit 1 – DRE** Transmit Data Register Empty Interrupt Disable

Writing a '0' to this bit has no effect.

Writing a '1' will clear the corresponding interrupt request.

Value	Description
0	The DRE interrupt is disabled.
1	The DRE interrupt is enabled.

**Bit 0 – RXC** Receive Data Register Full Interrupt Disable

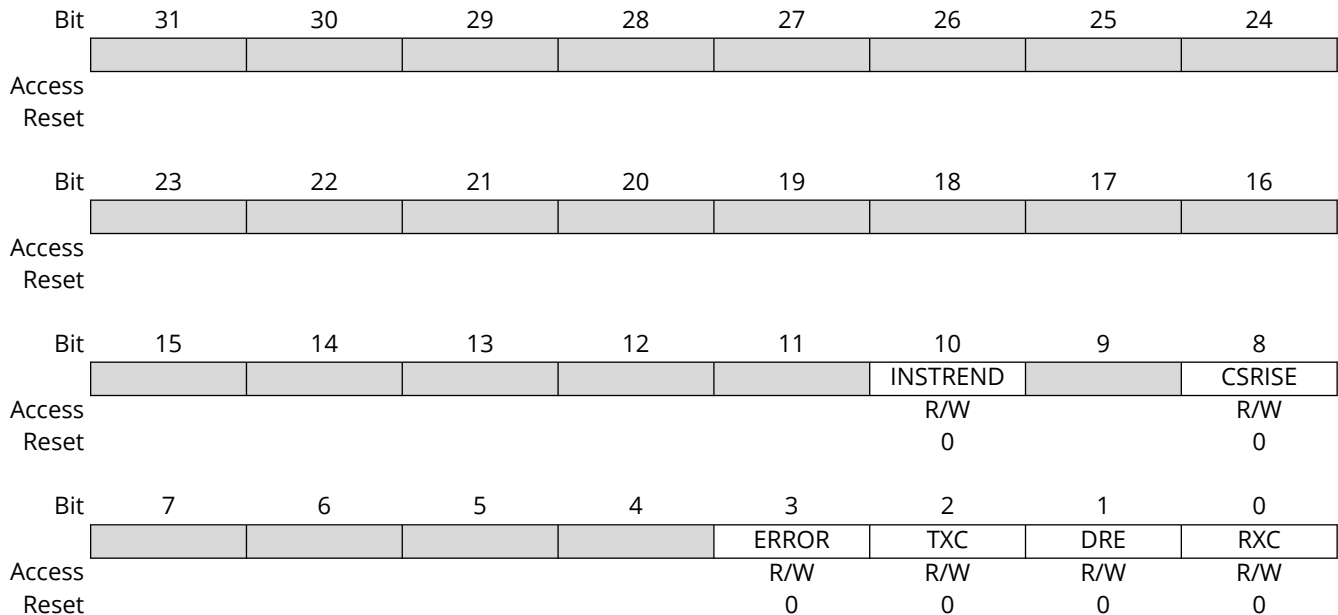
Writing a '0' to this bit has no effect.

Writing a '1' will clear the corresponding interrupt request.

Value	Description
0	The RXC interrupt is disabled.
1	The RXC interrupt is enabled.

### 35.7.7 Interrupt Enable Set

**Name:** INTENSET  
**Offset:** 0x18  
**Reset:** 0x00000000  
**Property:** PAC Write-Protection



**Bit 10 – INSTREND** Instruction End Interrupt Enable  
 Writing a '0' to this bit has no effect.  
 Writing a '1' will set the corresponding interrupt request.

Value	Description
0	The INSTREND interrupt is disabled.
1	The INSTREND interrupt is enabled.

**Bit 8 – CSRISE** Chip Select Rise Interrupt Enable  
 Writing a '0' to this bit has no effect.  
 Writing a '1' will set the corresponding interrupt request.

Value	Description
0	The CSRISE interrupt is disabled.
1	The CSRISE interrupt is enabled.

**Bit 3 – ERROR** Overrun Error Interrupt Enable  
 Writing a '0' to this bit has no effect.  
 Writing a '1' will set the corresponding interrupt request.

Value	Description
0	The ERROR interrupt is disabled.
1	The ERROR interrupt is enabled.

**Bit 2 – TXC** Transmission Complete Interrupt Enable  
 Writing a '0' to this bit has no effect.  
 Writing a '1' will set the corresponding interrupt request.

Value	Description
0	The TXC interrupt is disabled.
1	The TXC interrupt is enabled.

**Bit 1 – DRE** Transmit Data Register Empty Interrupt Enable

Writing a '0' to this bit has no effect.

Writing a '1' will set the corresponding interrupt request.

Value	Description
0	The DRE interrupt is disabled.
1	The DRE interrupt is enabled.

**Bit 0 – RXC** Receive Data Register Full Interrupt Enable

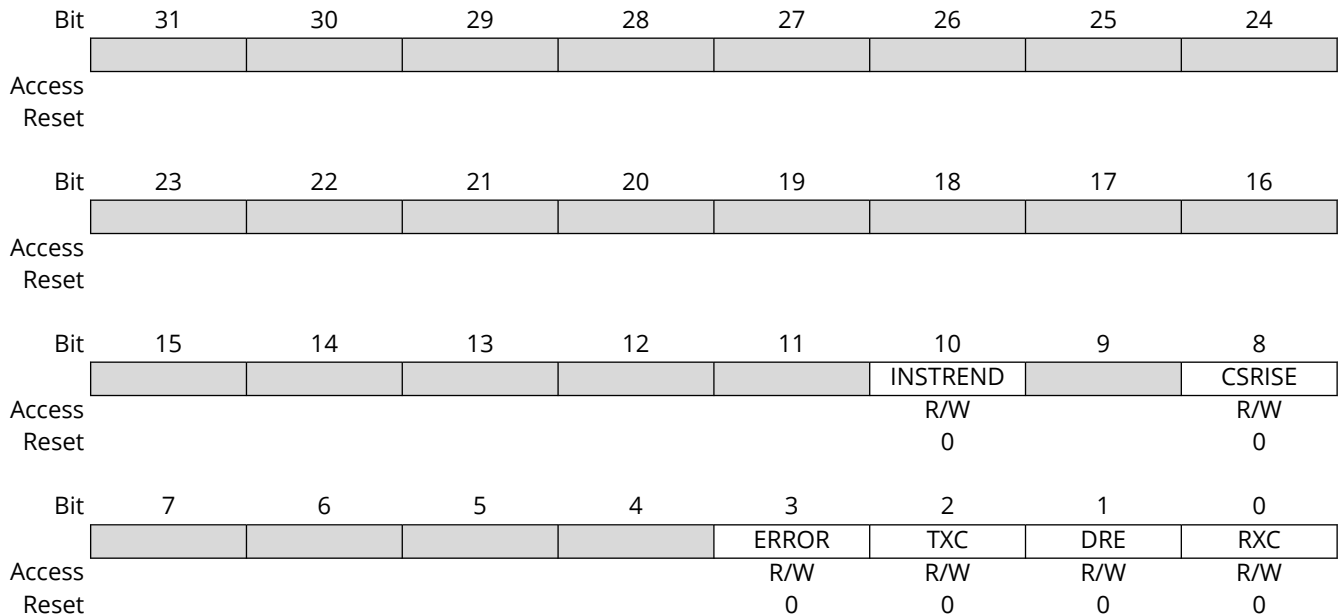
Writing a '0' to this bit has no effect.

Writing a '1' will set the corresponding interrupt request.

Value	Description
0	The RXC interrupt is disabled.
1	The RXC interrupt is enabled.

### 35.7.8 Interrupt Flag Status and Clear

**Name:** INTFLAG  
**Offset:** 0x1C  
**Reset:** 0x00000000  
**Property:** -



**Bit 10 – INSTREND** Instruction End  
 This bit is set when an Instruction End has been detected.  
 Writing a '0' to this bit has no effect.  
 Writing a '1' to this bit will clear the flag.

**Bit 8 – CSRISE** Chip Select Rise  
 The bit is set when a Chip Select Rise has been detected.  
 Writing a '0' to this bit has no effect.  
 Writing a '1' to this bit will clear the flag.

**Bit 3 – ERROR** Overrun Error  
 This bit is set when an ERROR has occurred.  
 An ERROR occurs when RXDATA is loaded at least twice from the serializer.  
 Writing a '0' to this bit has no effect.  
 Writing a '1' to this bit will clear the flag.

**Bit 2 – TXC** Transmission Complete  
 0: As soon as data is written in TXDATA.  
 1: TXDATA and internal shifter are empty. If a transfer delay has been defined, TXC is set after the completion of such delay.

**Bit 1 – DRE** Transmit Data Register Empty  
 0: Data has been written to TXDATA and not yet transferred to the serializer.  
 1: The last data written in the TXDATA has been transferred to the serializer.  
 This bit is '0' when the QSPI is disabled or at reset.  
 The bit is set as soon as ENABLE bit is set.



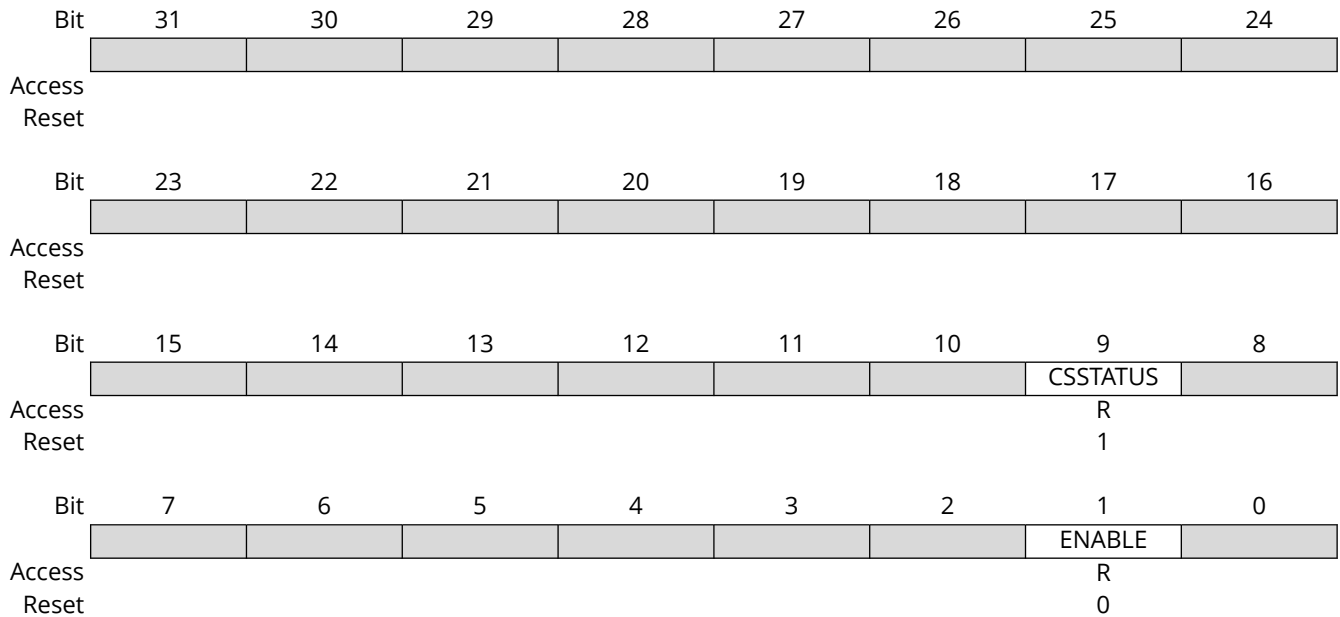
**Bit 0 – RXC** Receive Data Register Full

0: No data has been received since the last read of RXDATA.

1: Data has been received and the received data has been transferred from the serializer to RXDATA since the last read of RXDATA.

### 35.7.9 Status

**Name:** STATUS  
**Offset:** 0x20  
**Reset:** 0x00000200  
**Property:** -



#### Bit 9 - CSSTATUS Chip Select

Value	Description
0	Chip Select is asserted.
1	Chip Select is not asserted.

#### Bit 1 - ENABLE Enable

Value	Description
0	QSPI is disabled.
1	QSPI is enabled.

### 35.7.10 Instruction Address

**Name:** INSTRADDR  
**Offset:** 0x30  
**Reset:** 0x00000000  
**Property:** -

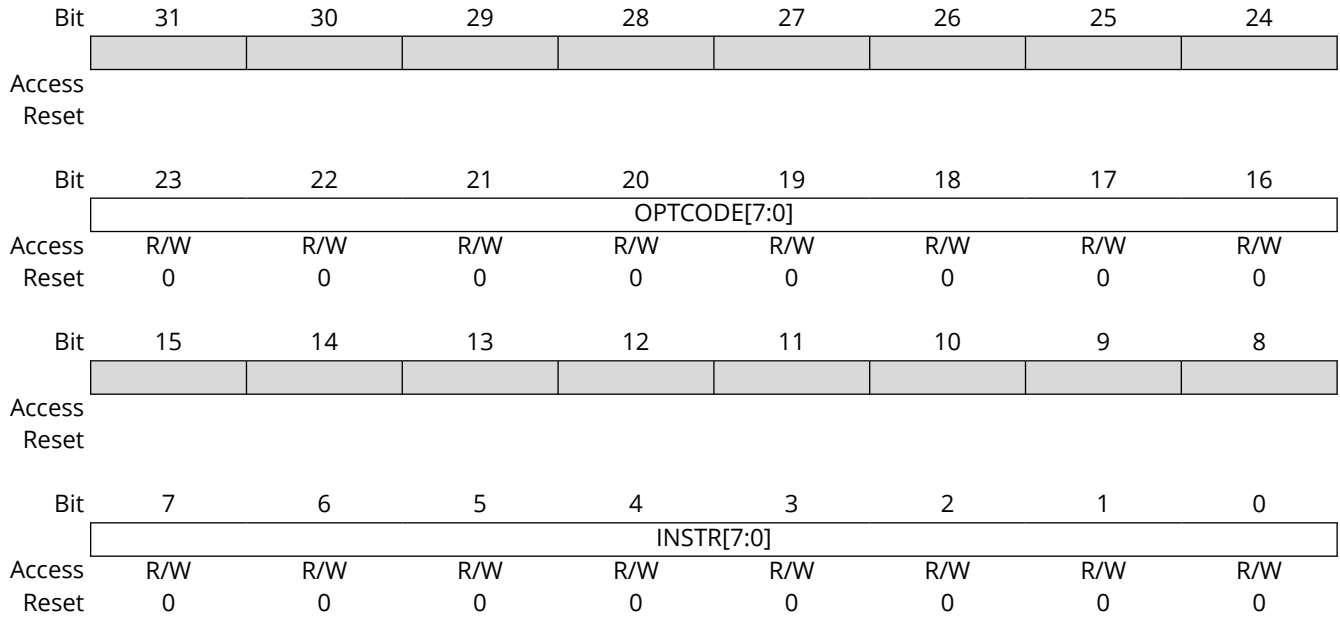
Bit	31	30	29	28	27	26	25	24
	ADDR[31:24]							
Access	R/W	R/W	R/W	R/W	R/W	R/W	R/W	R/W
Reset	0	0	0	0	0	0	0	0
Bit	23	22	21	20	19	18	17	16
	ADDR[23:16]							
Access	R/W	R/W	R/W	R/W	R/W	R/W	R/W	R/W
Reset	0	0	0	0	0	0	0	0
Bit	15	14	13	12	11	10	9	8
	ADDR[15:8]							
Access	R/W	R/W	R/W	R/W	R/W	R/W	R/W	R/W
Reset	0	0	0	0	0	0	0	0
Bit	7	6	5	4	3	2	1	0
	ADDR[7:0]							
Access	R/W	R/W	R/W	R/W	R/W	R/W	R/W	R/W
Reset	0	0	0	0	0	0	0	0

#### Bits 31:0 – ADDR[31:0] Instruction Address

Address to send to the serial flash memory in the instruction frame.

### 35.7.11 Instruction Code

**Name:** INSTRCTRL  
**Offset:** 0x34  
**Reset:** 0x00000000  
**Property:** -



**Bits 23:16 – OPTCODE[7:0]** Option Code

These bits define the option code to send to the serial flash memory.

**Bits 7:0 – INSTR[7:0]** Instruction Code

Instruction code to send to the serial flash memory.

### 35.7.12 Instruction Frame

**Name:** INSTRFRAME  
**Offset:** 0x38  
**Reset:** 0x00000000  
**Property:** -

Bit	31	30	29	28	27	26	25	24	
Access									
Reset									
Bit	23	22	21	20	19	18	17	16	
Access				DUMMYLEN[4:0]					
Reset				R/W	R/W	R/W	R/W	R/W	
				0	0	0	0	0	
Bit	15	14	13	12	11	10	9	8	
Access	DDREN	CRMODE	TFRTYPE[1:0]			ADDRLLEN	OPTCODELEN[1:0]		
Reset	R/W	R/W	R/W	R/W		R/W	R/W	R/W	
	0	0	0	0		0	0	0	
Bit	7	6	5	4	3	2	1	0	
Access	DATAEN	OPTCODEEN	ADDREN	INSTREN		WIDTH[2:0]			
Reset	R/W	R/W	R/W	R/W		R/W	R/W	R/W	
	0	0	0	0		0	0	0	

#### Bits 20:16 – DUMMYLEN[4:0] Dummy Cycles Length

The DUMMYLEN field defines the number of dummy cycles required by the serial Flash memory before data transfer.

#### Bit 15 – DDREN Double Data Rate Enable

**Note:** Double Data Rate operating is only supported in Read.

Value	Description
0	Double Data Rate operating mode is disabled.
1	Double Data Rate operating mode is enabled.

#### Bit 14 – CRMODE Continuous Read Mode

This bit defines if the Continuous Read Mode is enabled or disabled.

Value	Description
0	Continuous Read Mode is disabled.
1	Continuous Read Mode is enabled.

#### Bits 13:12 – TFRTYPE[1:0] Data Transfer Type

These bits define the data type transfer.

Value	Name	Description
0x0	READ	Read transfer from the serial memory. Scrambling is not performed. Read at random location (fetch) in the serial flash memory is not possible.
0x1	READMEMORY	Read data transfer from the serial memory. If enabled, scrambling is performed. Read at random location (fetch) in the serial flash memory is possible.
0x2	WRITE	Write transfer into the serial memory. Scrambling is not performed.
0x3	WRITEMEMORY	Write data transfer into the serial memory. If enabled, scrambling is performed.

### Bit 10 – ADDRLEN Address Length

The ADDRLEN bit determines the length of the address.

Value	Name	Description
0x0	24BITS	24-bits address length
0x1	32BITS	32-bits address length

### Bits 9:8 – OPTCODELEN[1:0] Option Code Length

The OPTCODELEN field determines the length of the option code. The value written in OPTCODELEN must be coherent with value written in the field WIDTH. For example: OPTCODELEN=0 (1-bit option code) is not coherent with WIDTH=6 (option code sent with QuadSPI protocol, thus the minimum length of the option code is 4-bit).

Value	Name	Description
0x0	1BIT	1-bit length option code
0x1	2BITS	2-bits length option code
0x2	4BITS	4-bits length option code
0x3	8BITS	8-bits length option code

### Bit 7 – DATAEN Data Enable

Value	Description
0	No data is sent/received to/from the serial flash memory.
1	Data is sent/received to/from the serial flash memory.

### Bit 6 – OPTCODEEN Option Enable

Value	Description
0	The option is not sent to the serial flash memory
1	The option is sent to the serial flash memory.

### Bit 5 – ADDREN Address Enable

Value	Description
0	The transfer address is not sent to the serial flash memory.
1	The transfer address is sent to the serial flash memory.

### Bit 4 – INSTREN Instruction Enable

Value	Description
0	The instruction is not sent to the serial flash memory.
1	The instruction is sent to the serial flash memory.

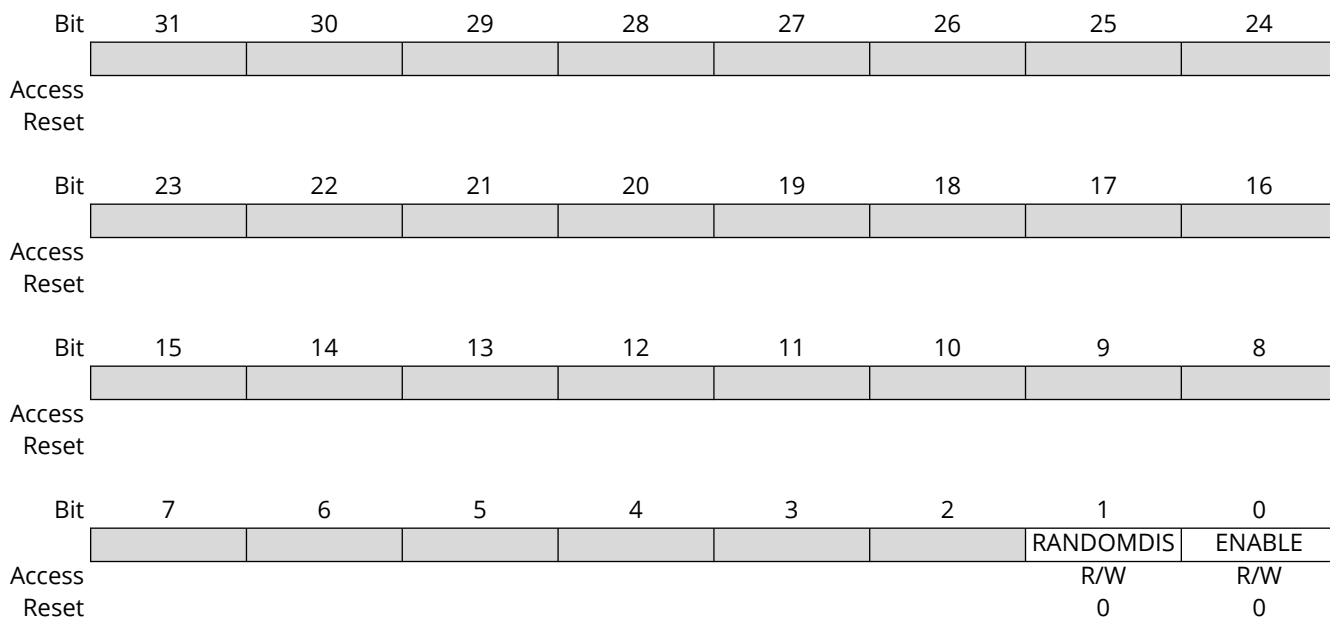
### Bits 2:0 – WIDTH[2:0] Instruction Code, Address, Option Code and Data Width

This field defines the width of the instruction code, the address, the option and the data.

Value	Name	Description
0x0	SINGLE_BIT_SPI	Instruction: Single-bit SPI / Address-Option: Single-bit SPI / Data: Single-bit SPI
0x1	DUAL_OUTPUT	Instruction: Single-bit SPI / Address-Option: Single-bit SPI / Data: Dual SPI
0x2	QUAD_OUTPUT	Instruction: Single-bit SPI / Address-Option: Single-bit SPI / Data: Quad SPI
0x3	DUAL_IO	Instruction: Single-bit SPI / Address-Option: Dual SPI / Data: Dual SPI
0x4	QUAD_IO	Instruction: Single-bit SPI / Address-Option: Quad SPI / Data: Quad SPI
0x5	DUAL_CMD	Instruction: Dual SPI / Address-Option: Dual SPI / Data: Dual SPI
0x6	QUAD_CMD	Instruction: Quad SPI / Address-Option: Quad SPI / Data: Quad SPI
0x7		Reserved

### 35.7.13 Scrambling Mode

**Name:** SCRAMBCTRL  
**Offset:** 0x40  
**Reset:** 0x00000000  
**Property:** PAC Write-Protection



#### Bit 1 - RANDOMDIS Scrambling/Unscrambling Random Value Disable

Value	Description
0	The scrambling/unscrambling algorithm includes the scrambling user key plus a random value that may differ from chip to chip.
1	The scrambling/unscrambling algorithm includes only the scrambling user key.

#### Bit 0 - ENABLE Scrambling/Unscrambling Enable

This bit defines if the scrambling/unscrambling is enabled or disabled.

Value	Description
0	Scrambling/unscrambling is disabled.
1	Scrambling/unscrambling is enabled.

### 35.7.14 Scrambling Key

**Name:** SCRAMBKEY  
**Offset:** 0x44  
**Reset:** 0x00000000  
**Property:** PAC Write-Protection

Bit	31	30	29	28	27	26	25	24
	KEY[31:24]							
Access	W	W	W	W	W	W	W	W
Reset	0	0	0	0	0	0	0	0
Bit	23	22	21	20	19	18	17	16
	KEY[23:16]							
Access	W	W	W	W	W	W	W	W
Reset	0	0	0	0	0	0	0	0
Bit	15	14	13	12	11	10	9	8
	KEY[15:8]							
Access	W	W	W	W	W	W	W	W
Reset	0	0	0	0	0	0	0	0
Bit	7	6	5	4	3	2	1	0
	KEY[7:0]							
Access	W	W	W	W	W	W	W	W
Reset	0	0	0	0	0	0	0	0

**Bits 31:0 – KEY[31:0]** Scrambling User Key  
 This field defines the user key value.



## 36. SD/MMC Host Controller (SDHC)

### 36.1 Overview

The SD/MMC Host Controller (SDHC) supports the embedded MultiMedia Card (e.MMC) Specification, the SD Memory Card Specification, and the SDIO Specification. It is compliant with the SD Host Controller Standard specifications. Refer to [36.1.1. Reference Documents](#) for details.

The SDHC includes the register set defined in the “SD Host Controller Simplified Specification V3.00” and additional registers to manage e.MMC devices and enhanced features.

The SDHC is clocked by up to three clocks (bus clock, SDHC core clock, and a slow clock for certain functions). Both the MCLK and GCLK must be configured before the SDHC can be used.

The PIC32CX SG41/SG60/SG61 provides two instances of the SDHC, SDHC0 and SDHC1.

#### 36.1.1 Reference Documents

Name	Link
SD Host Controller Simplified Specification V3.00	<a href="http://www.sdcard.org">www.sdcard.org</a>
SDIO Simplified Specification V3.00	
Physical Layer Simplified Specification V3.01	
Embedded MultiMedia Card (e.MMC) Electrical Standard 4.51	<a href="http://www.jedec.org">www.jedec.org</a>

### 36.2 Features

The following are key feature of the SDHC module:

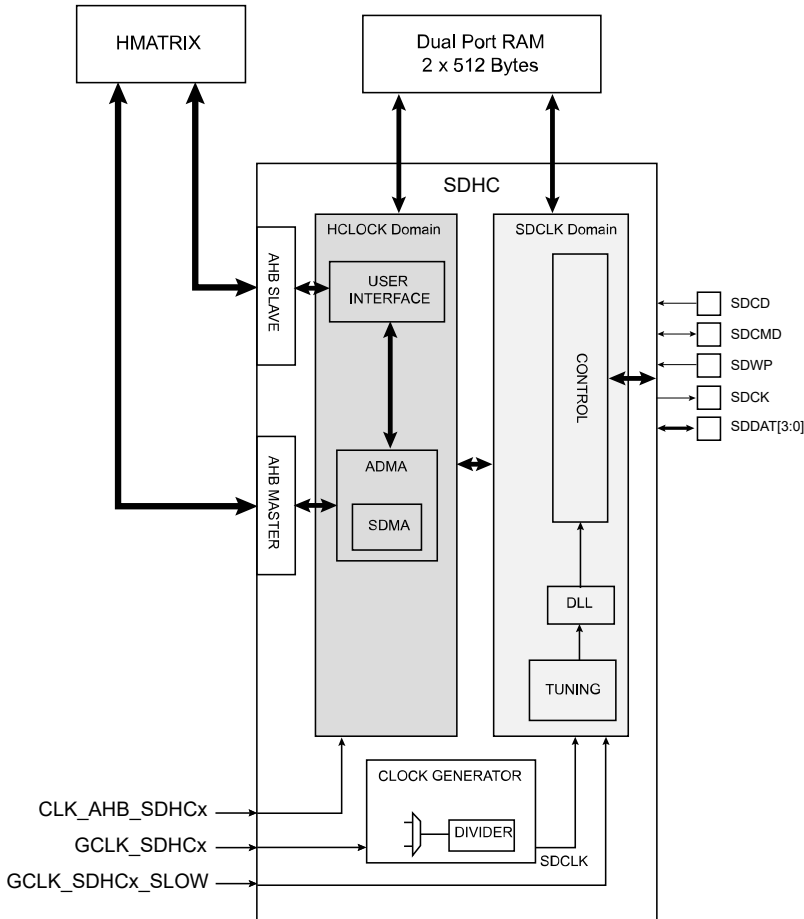
- Compatibility:
  - SD Host Controller Standard Specification
  - MultiMedia Card Specification
  - SD Memory Card Specification
  - SDIO Specification Version

Refer to [36.1.1. Reference Documents](#) for details.

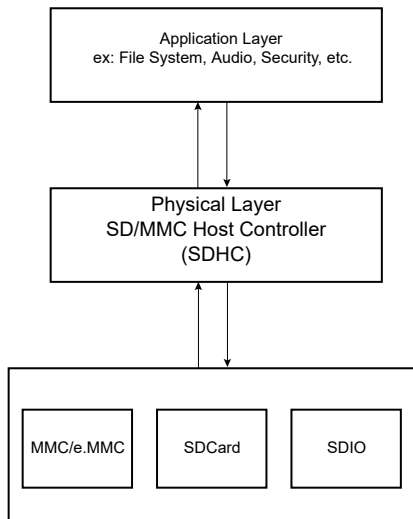
- Support for 1-bit/ 4-bit SD/SDIO Devices
- Support for 1-bit/4-bit e.MMC Devices
- Support for SD/SDIO Default Speed (Maximum SDCLK Frequency = 25 MHz)
- Support for SD/SDIO High Speed (Maximum SDCLK Frequency = 50 MHz)
- Support for e.MMC Default Speed (Maximum SDCLK Frequency = 26 MHz)
- e.MMC Boot Operation Mode Support
- Support for Block Size from 1 to 512 bytes
- Support for Stream, Block and Multi-block Data Read and Write – Advanced DMA and SDMA Capability
- Internal 1024-byte Dual Port RAM
- Support for both synchronous and asynchronous abort
- Supports for SDIO Card Interrupt

### 36.3 Block Diagrams

#### 36.3.1 Block Diagram



#### 36.3.2 Application Block Diagram



## 36.4 Signal Description

Signal Name	Type	Description
SDCD	Input	SD Card / SDIO /e.MMC Card Detect
SDCMD	I/O	SD Card / SDIO /e.MMC Command/ Response Line
SDWP	Input	SD Card Connector Write Protect Signal
SDCK	Output	SD Card / SDIO /e.MMC Clock Signal
SDDAT[3:0]	I/O	SD Card / SDIO /e.MMC data lines

## 36.5 Peripheral Dependencies

### 36.5.1 I/O Lines

In order to use the I/O lines, the I/O pins must be configured using the [I/O Pin Controller \(PORT\)](#).

### 36.5.2 Power Management

This peripheral can continue to operate in any sleep mode where its source clock is running. Refer to the [PM – Power Manager](#) for details on the different sleep modes.

### 36.5.3 Clocks

The peripheral is using two generic clocks and one bus clock.

The clock for the SDHC bus interface (CLK\_AHB\_SDHC) is enabled and disabled by the Main Clock Controller. The default state of CLK\_AHB\_SDHC can be found in the [Peripheral Clock Masking](#) section.

The two generic clocks are:

- The core clock GCLK\_SDHCx is required to clock the SDHC core.
- The slow clock GCLK\_SDHCx\_SLOW is only required for certain functions. When this clock is required, GCLK\_SDHCx must be enabled.

These clocks must be configured and enabled in the [Generic Clock Controller \(GCLK\)](#) before using the SDHC. The generic clocks are asynchronous to the user interface clock (CLK\_SDHCx\_AHB).

### 36.5.4 Interrupts

The interrupt request line is connected to the Interrupt Controller. In order to use interrupt requests of this peripheral, the Interrupt Controller ([NVIC](#)) must be configured first.

## 36.6 Functional Description

### 36.6.1 SD/SDIO Operating Mode

This peripheral is fully compliant with the "SD Host Controller Simplified Specification V3.00" for SD/SDIO devices. Refer to this specification for configuration.

Refer to "Physical Layer Simplified Specification V3.01" and "SDIO Simplified Specification V3.00" for SD/SDIO management.

### 36.6.2 e.MMC Operating Mode

This peripheral supports e.MMC devices management. As the "SD Host Controller Simplified Specification V3.00" does not apply to e.MMC devices, some registers have been added to those described in this specification in order to manage e.MMC devices. Most of the registers described in the "SD Host Controller Simplified Specification V3.00" must be used for e.MMC management, but e.MMC-specific features are managed using MC1R and MC2R.

## 36.7 Register Summary

Offset	Name	Bit Pos.	7	6	5	4	3	2	1	0
0x00	SSAR	7:0	ADDR[7:0]							
		15:8	ADDR[15:8]							
		23:16	ADDR[23:16]							
		31:24	ADDR[31:24]							
0x04	BSR	7:0	BLOCKSIZE[7:0]							
		15:8	BOUNDARY[2:0]							BLOCKSIZE[9:8]
0x06	BCR	7:0	BCNT[7:0]							
		15:8	BCNT[15:8]							
0x08	ARG1R	7:0	ARG[7:0]							
		15:8	ARG[15:8]							
		23:16	ARG[23:16]							
		31:24	ARG[31:24]							
0x0C	TMR	7:0			MSBSEL	DTDSEL	ACMDEN[1:0]		BCEN	DMAEN
		15:8								
0x0E	CR	7:0	CMDTYP[1:0]		DPSEL	CMDICEN	CMDCCEN	RESPTYP[1:0]		
		15:8	CMDIDX[5:0]							
0x10	RR0	7:0	CMDRESP[7:0]							
		15:8	CMDRESP[15:8]							
		23:16	CMDRESP[23:16]							
		31:24	CMDRESP[31:24]							
0x14	RR1	7:0	CMDRESP[7:0]							
		15:8	CMDRESP[15:8]							
		23:16	CMDRESP[23:16]							
		31:24	CMDRESP[31:24]							
0x18	RR2	7:0	CMDRESP[7:0]							
		15:8	CMDRESP[15:8]							
		23:16	CMDRESP[23:16]							
		31:24	CMDRESP[31:24]							
0x1C	RR3	7:0	CMDRESP[7:0]							
		15:8	CMDRESP[15:8]							
		23:16	CMDRESP[23:16]							
		31:24	CMDRESP[31:24]							
0x20	BDPR	7:0	BUFDATA[7:0]							
		15:8	BUFDATA[15:8]							
		23:16	BUFDATA[23:16]							
		31:24	BUFDATA[31:24]							
0x24	PSR	7:0					RTREQ	DLACT	CMDINH	CMDINH
		15:8					BUFRDEN	BUFWRN	RTACT	WTACT
		23:16	DATLL[3:0]			WRPPL	CARDDDL	CARDSS	CARDINS	
		31:24	CMDLL							
0x28	HC1R	7:0	CARDSEL	CARDDTL	DMASEL[1:0]		HSEN	DW	LEDCTRL	
0x29	PCR	7:0	SDBVSEL[2:0]							
0x2A	BGCR	7:0					INTBG	RWCTRL	CONTR	STPBGR
0x2B	WCR	7:0					WKENCREM	WKENCINS	WKENCINT	
0x2C	CCR	7:0	USDCLKFSEL[1:0]		CLKGSEL					
		15:8	SDCLKFSEL[7:0]							
0x2E	TCR	7:0	DTCVAL[3:0]							
0x2F	SRR	7:0					SWRSTDAT	SWRSTCMD	SWRSTALL	
0x30	NISTR	7:0	CREM	CINS	BRDRDY	BWRRDY	DMAINT	BLKGE	TRFC	CMDC
		15:8	ERRINT	BOOTAR						
0x32	EISTR	7:0	CURLIM	DATEND	DATCRC	DATTEO	CMDIDX	CMDEND	CMDCRC	CMDTEO
		15:8					BOOTAE	ADMA		
0x34	NISTER	7:0	CREM	CINS	BRDRDY	BWRRDY	DMAINT	BLKGE	TRFC	CMDC
		15:8					BOOTAR	CINT		
0x36	EISTER	7:0	CURLIM	DATEND	DATCRC	DATTEO	CMDIDX	CMDEND	CMDCRC	CMDTEO
		15:8					BOOTAE	ADMA		
0x38	NISIER	7:0	CREM	CINS	BRDRDY	BWRRDY	DMAINT	BLKGE	TRFC	CMDC
		15:8					BOOTAR	CINT		

.....continued

Offset	Name	Bit Pos.	7	6	5	4	3	2	1	0	
0x3A	EISIER	7:0	CURLIM	DATEND	DATCRC	DATTEO	CMDIDX	CMDEND	CMDCRC	CMDTEO	
		15:8				BOOTAE			ADMA	ACMD	
0x3C	ACESR	7:0	CMDNI			ACMDIDX	ACMDEND	ACMDCRC	ACMDTEO	ACMD12NE	
		15:8									
0x3E	HC2R - EMMC	7:0	SCLKSEL	EXTUN	DRVSEL[1:0]		HS200EN[3:0]				
		15:8	PVALEN								
0x3E	HC2R - DEFAULT	7:0	SCLKSEL	EXTUN	DRVSEL[1:0]		VS18EN	UHSMS[2:0]			
		15:8	PVALEN	ASINTEN							
0x40	CA0R	7:0	TEOCLKU		TEOCLKF[5:0]						
		15:8	BASECLKF[7:0]								
		23:16	SRSUP	SDMASUP	HSSUP	ADMA2SUP		ED8SUP	MAXBLKL[1:0]		
		31:24	SLTYPE[1:0]		ASINTSUP	SB64SUP		V18VSUP	V30VSUP	V33VSUP	
0x44	CA1R	7:0		DRVDSUP	DRVCSUP	DRVASUP		DDR50SUP	SDR104SUP	SDR50SUP	
		15:8			TSDR50		TCNTRT[3:0]				
		23:16	CLKMULT[7:0]								
		31:24									
0x48	MCCAR	7:0	MAXCUR33V[7:0]								
		15:8	MAXCUR30V[7:0]								
		23:16	MAXCUR18V[7:0]								
		31:24									
0x4C ... 0x4F	Reserved										
0x50	FERACES	7:0	CMDNI			ACMDIDX	ACMDEND	ACMDCRC	ACMDTEO	ACMD12NE	
		15:8									
0x52	FEREIS	7:0	CURLIM	DATEND	DATCRC	DATTEO	CMDIDX	CMDEND	CMDCRC	CMDTEO	
		15:8				BOOTAE			ADMA	ACMD	
0x54	AESR	7:0						LMIS	ERRST[1:0]		
0x55 ... 0x57	Reserved										
0x58	ASAR	7:0	ADMASA[7:0]								
		15:8	ADMASA[15:8]								
		23:16	ADMASA[23:16]								
		31:24	ADMASA[31:24]								
0x5C ... 0x5F	Reserved										
0x60	PVR0	7:0	SDCLKFSEL[7:0]								
		15:8	DRVSEL[1:0]							CLKGSEL	SDCLKFSEL[9:8]
0x62	PVR1	7:0	SDCLKFSEL[7:0]								
		15:8	DRVSEL[1:0]							CLKGSEL	SDCLKFSEL[9:8]
0x64	PVR2	7:0	SDCLKFSEL[7:0]								
		15:8	DRVSEL[1:0]							CLKGSEL	SDCLKFSEL[9:8]
0x66	PVR3	7:0	SDCLKFSEL[7:0]								
		15:8	DRVSEL[1:0]							CLKGSEL	SDCLKFSEL[9:8]
0x68	PVR4	7:0	SDCLKFSEL[7:0]								
		15:8	DRVSEL[1:0]							CLKGSEL	SDCLKFSEL[9:8]
0x6A	PVR5	7:0	SDCLKFSEL[7:0]								
		15:8	DRVSEL[1:0]							CLKGSEL	SDCLKFSEL[9:8]
0x6C	PVR6	7:0	SDCLKFSEL[7:0]								
		15:8	DRVSEL[1:0]							CLKGSEL	SDCLKFSEL[9:8]
0x6E	PVR7	7:0	SDCLKFSEL[7:0]								
		15:8	DRVSEL[1:0]							CLKGSEL	SDCLKFSEL[9:8]
0x70 ... 0xFB	Reserved										
0xFC	SISR	7:0									
		15:8	INTSSL[1:0]								
0xFE	HCVR	7:0	SVER[7:0]								
		15:8	VVER[7:0]								

.....continued

Offset	Name	Bit Pos.	7	6	5	4	3	2	1	0	
0x0100 ... 0x01FF	Reserved										
0x0200	APSR	7:0					HDATLL[3:0]				
		15:8									
		23:16									
		31:24									
0x0204	MC1R	7:0	FCD	RSTN	BOOTA	OPD	DDR		CMDTYP[1:0]		
0x0205	MC2R	7:0							ABOOT	SRESP	
0x0206 ... 0x0207	Reserved										
0x0208	ACR	7:0							BMAX[1:0]		
		15:8									
		23:16									
		31:24									
0x020C	CC2R	7:0								FSDCLKD	
		15:8									
		23:16									
		31:24									
0x0210 ... 0x022F	Reserved										
0x0230	CACR	7:0								CAPWREN	
		15:8	KEY[7:0]								
		23:16									
		31:24									
0x0234	DBGR	7:0								NIDBG	
		15:8									

### 36.7.1 SDMA System Address / Argument 2 Register

**Name:** SSAR  
**Offset:** 0x00  
**Reset:** 0x00000000  
**Property:** -

This register contains the physical system memory address used for SDMA transfers or the second argument for Auto CMD23.

Bit	31	30	29	28	27	26	25	24
	ADDR[31:24]							
Access	R/W	R/W	R/W	R/W	R/W	R/W	R/W	R/W
Reset	0	0	0	0	0	0	0	0
Bit	23	22	21	20	19	18	17	16
	ADDR[23:16]							
Access	R/W	R/W	R/W	R/W	R/W	R/W	R/W	R/W
Reset	0	0	0	0	0	0	0	0
Bit	15	14	13	12	11	10	9	8
	ADDR[15:8]							
Access	R/W	R/W	R/W	R/W	R/W	R/W	R/W	R/W
Reset	0	0	0	0	0	0	0	0
Bit	7	6	5	4	3	2	1	0
	ADDR[7:0]							
Access	R/W	R/W	R/W	R/W	R/W	R/W	R/W	R/W
Reset	0	0	0	0	0	0	0	0

#### Bits 31:0 – ADDR[31:0] SDMA System Address/Argument 2

The function of this bit field is depending on the operation mode:

For a SDMA transfer, this field is the system memory address. When the peripheral stops an SDMA transfer, this field points to the system address of the next contiguous data position. This field can be accessed only if no transaction is executing (i.e., after a transaction has stopped). Read operations during transfers may return an invalid value. An interrupt can be generated to instruct the software to update this field. Writing the next system address of the next data position restarts the SDMA transfer.

When executing Auto CMD23, this field is used with Auto CMD23 to set a 32-bit block count value to the CMD23 argument. If Auto CMD23 is used with ADMA, the full 32-bit block count value can be used. If Auto CMD23 is used without ADMA, the available block count value is limited by BCR. In this case, 65535 blocks is the maximum value.

### 36.7.2 Block Size Register

**Name:** BSR  
**Offset:** 0x04  
**Reset:** 0x0000  
**Property:** -

Bit	15	14	13	12	11	10	9	8
	BOUNDARY[2:0]						BLOCKSIZE[9:8]	
Access		-	-	-			R/W	R/W
Reset		0	0	0			0	0
Bit	7	6	5	4	3	2	1	0
	BLOCKSIZE[7:0]							
Access	R/W	R/W	R/W	R/W	R/W	R/W	R/W	R/W
Reset	0	0	0	0	0	0	0	0

#### Bits 14:12 – BOUNDARY[2:0] SDMA Buffer Boundary

This field specifies the size of the contiguous buffer in the system memory. The SDMA transfer waits at every boundary specified by this field and the peripheral generates the DMA Interrupt to instruct the software to update SSAR. If this field is set to 0 (buffer size = 4 Kbytes), the lowest 12 bits of SSAR.ADDRESS point to data in the contiguous buffer, and the upper 20 bits point to the location of the buffer in the system memory. This function is active when the DMA Enable bit in the Transfer Mode Register (TMR.DMAEN) is '1'.

Value	Name	Description
0	4K	4-Kbyte boundary
1	8K	8-Kbyte boundary
2	16K	16-Kbyte boundary
3	32K	32-Kbyte boundary
4	64K	64-Kbyte boundary
5	128K	128-Kbyte boundary
6	256k	256-Kbyte boundary
7	512K	512-Kbyte boundary

#### Bits 9:0 – BLOCKSIZE[9:0] Transfer Block Size

This field specifies the block size of data transfers for CMD17, CMD18, CMD24, CMD25 and CMD53. Values ranging from 1 to 512 can be set. It can be accessed only if no transaction is executing (i.e., after a transaction has stopped). Read operations during transfers may return an invalid value, and write operations are ignored.



### 36.7.3 Block Count Register

**Name:** BCR  
**Offset:** 0x06  
**Reset:** 0x0000  
**Property:** -

Bit	15	14	13	12	11	10	9	8
	BCNT[15:8]							
Access	R/W	R/W	R/W	R/W	R/W	R/W	R/W	R/W
Reset	0	0	0	0	0	0	0	0
Bit	7	6	5	4	3	2	1	0
	BCNT[7:0]							
Access	R/W	R/W	R/W	R/W	R/W	R/W	R/W	R/W
Reset	0	0	0	0	0	0	0	0

#### Bits 15:0 – BCNT[15:0] Block Count for Current Transfer

This field is used only if TMR.BCEN (Block Count Enable) is set to 1 and is valid only for multiple block transfers. BCNT is the number of blocks to be transferred and it must be set to a value between 1 and the maximum block count. The peripheral decrements the block count after each block transfer and stops when the count reaches 0. When this field is set to 0, no data block is transferred.

This register should be accessed only when no transaction is executing (i.e., after transactions are stopped). During data transfer, read operations on this register may return an invalid value and write operations are ignored.

When a suspend command is completed, the number of blocks yet to be transferred can be determined by reading this register. Before issuing a resume command, the previously saved block count is restored.

### 36.7.4 Argument 1 Register

**Name:** ARG1R  
**Offset:** 0x08  
**Reset:** 0x00000000  
**Property:** Read/Write

Bit	31	30	29	28	27	26	25	24
	ARG[31:24]							
Access	R/W	R/W	R/W	R/W	R/W	R/W	R/W	R/W
Reset	0	0	0	0	0	0	0	0
Bit	23	22	21	20	19	18	17	16
	ARG[23:16]							
Access	R/W	R/W	R/W	R/W	R/W	R/W	R/W	R/W
Reset	0	0	0	0	0	0	0	0
Bit	15	14	13	12	11	10	9	8
	ARG[15:8]							
Access	R/W	R/W	R/W	R/W	R/W	R/W	R/W	R/W
Reset	0	0	0	0	0	0	0	0
Bit	7	6	5	4	3	2	1	0
	ARG[7:0]							
Access	R/W	R/W	R/W	R/W	R/W	R/W	R/W	R/W
Reset	0	0	0	0	0	0	0	0

#### Bits 31:0 – ARG[31:0] Argument

This register contains the SD command argument which is specified as the bit 39-8 of Command-Format in the “Physical Layer Simplified Specification V3.01” or “Embedded MultiMedia Card (e.MMC) Electrical Standard 4.51”.

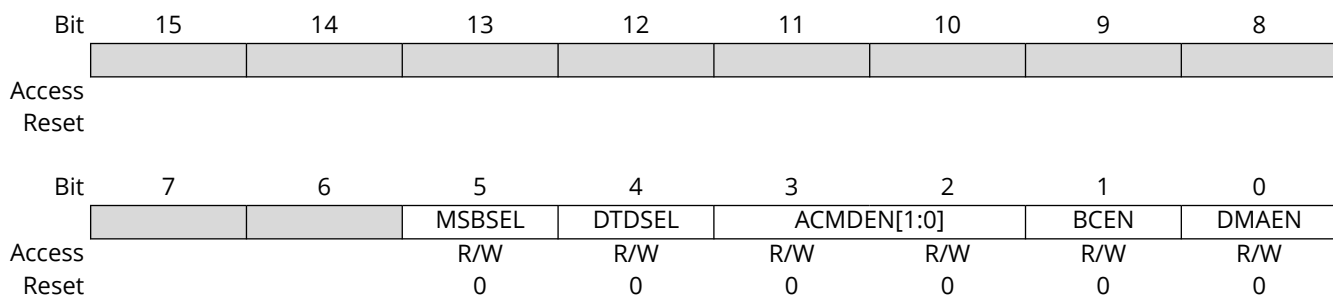
### 36.7.5 Transfer Mode Register

**Name:** TMR  
**Offset:** 0x0C  
**Reset:** 0x0000  
**Property:** -

This register is used to control data transfers. The user shall set this register before issuing a command which transfers data (refer to bit DPSEL in CR), or before issuing a Resume command. The user must save the value of this register when the data transfer is suspended (as a result of a Suspend command) and restore it before issuing a Resume command. To prevent data loss, this register cannot be written while data transactions are in progress. Writes to this register are ignored when bit PSR.CMDINH is '1'.

**Table 36-1.** Determining the Transfer Type

MSBSEL	BCEN	BCR.BCNT	Function
0	Don't care	Don't care	Single Transfer
1	0	Don't care	Infinite Transfer
1	1	Not Zero	Multiple Transfer
1	1	Zero	Stop Multiple Transfer



#### Bit 5 – MSBSEL Multi/Single Block Selection

Write this bit to '1' when issuing multiple-block transfer commands using DAT line(s). For any other commands, write this bit to 0. If this bit is 0, it is not necessary to write BCR to '1' (refer to [Table 1-4](#)).

#### Bit 4 – DTSEL Data Transfer Direction Selection

This bit defines the direction of the DAT lines data transfers. Write this bit to '1' to transfer data from the device (SD Card/SDIO/eMMC) to the peripheral. Write this bit to '0' for all other commands.

Value	Name	Description
0	WRITE	Writes data from the peripheral to the device.
1	READ	Reads data from the device to the peripheral.

#### Bits 3:2 – ACMDEN[1:0] Auto Command Enable

Two methods can be used to stop Multiple-block read and write operation:

1. Auto CMD12: when the ACMDEN field is set to 1, the peripheral issues CMD12 automatically when the last block transfer is completed. An Auto CMD12 error is indicated to ACESR. Auto CMD12 is not enabled if the command does not require CMD12.
2. Auto CMD23: when the ACMDEN field is set to 2, the peripheral issues a CMD23 automatically before issuing a command specified in CR.

The following conditions are required to use Auto CMD23:

- A memory card that supports CMD23 (SCR[33] = 1)
- If DMA is used, it must be ADMA (SDMA not supported).

- Only CMD18 or CMD25 is issued.

**Note:** The peripheral does not check the command index.

Auto CMD23 can be used with or without ADMA. By writing CR, the peripheral issues a CMD23 first and then issues a command specified by the CR.CMDIDX field. If CMD23 response errors are detected, the second command is not issued. A CMD23 error is indicated in ACESR. The CMD23 argument (32-bit block count value) is defined in SSAR.

This field determines the use of auto command functions.

Value	Name	Description
0	DISABLED	Auto Command Disabled
1	CMD12	Auto CMD12 Enabled
2	CMD23	Auto CMD23 Enabled
3	Reserved	Reserved

#### Bit 1 – BCEN Block Count Enable

This bit is used to enable BCR, which is only relevant for multiple block transfers. When this bit is 0, BCR is disabled, which is useful when executing an infinite transfer (refer to [Table 1-4](#)). If an ADMA2 transfer is more than 65535 blocks, this bit is set to 0 and the data transfer length is designated by the Descriptor Table.

Value	Name	Description
0	DISABLE	Block count is disabled
1	ENABLE	Block count is enabled

#### Bit 0 – DMAEN DMA Enable

This bit enables the DMA functionality described in section “Supporting DMA” in “SD Host Controller Simplified Specification V3.00” . DMA can be enabled only if it is supported as indicated by the bit CA0R.ADMA2SUP. One of the DMA modes can be selected using the field HC1R.DMASEL. If DMA is not supported, this bit is meaningless and then always reads 0. When this bit is set to 1, a DMA operation begins when the user writes to the upper byte of CR.

Value	Name	Description
0	DISABLE	DMA functionality is disabled
1	ENABLE	DMA functionality is enabled

### 36.7.6 Command Register

**Name:** CR  
**Offset:** 0x0E  
**Reset:** 0x0000  
**Property:** -

Bit	15	14	13	12	11	10	9	8
			CMDIDX[5:0]					
Access			R/W	R/W	R/W	R/W	R/W	R/W
Reset			0	0	0	0	0	0
Bit	7	6	5	4	3	2	1	0
	CMDTYP[1:0]		DPSEL	CMDICEN	CMDCCEN		RESPTYP[1:0]	
Access	R/W	R/W	R/W	-	R/W		R/W	R/W
Reset	0	0	0	0	0		0	0

#### Bits 13:8 – CMDIDX[5:0] Command Index

This bit shall be set to the command number (CMD0-63, ACMD0-63) that is specified in bits 45-40 of the Command-Format in the “Physical Layer Simplified Specification V3.01”, “SDIO Simplified Specification V3.00”, and “Embedded MultiMedia Card (e.MMC) Electrical Standard 4.51”.

#### Bits 7:6 – CMDTYP[1:0] Command Type

Value	Name	Description
0	NORMAL	Other commands
1	SUSPEND	CMD52 to write “Bus Suspend” in the Card Common Control Registers (CCCR) (for SDIO only)
2	RESUME	CMD52 to write “Function Select” in the Card Common Control Registers (CCCR) (for SDIO only)
3	ABORT	CMD12, CMD52 to write “I/O Abort” in the Card Common Control Registers (CCCR) (for SDIO only)

#### Bit 5 – DPSEL Data Present Select

This bit is set to 1 to indicate that data is present and shall be transferred using the DAT lines. It is set to 0 for the following:

1. Commands using only CMD line (Ex. CMD52)
2. Commands with no data transfer but using Busy signal on DAT[0] line (Ex. CMD38)
3. Resume command

Value	Description
0	No data present
1	Data present

#### Bit 4 – CMDICEN Command Index Check Enable

If this bit is set to 1, the peripheral checks the Index field in the response to see if it has the same value as the command index. If it has not, it is reported as a Command Index Error (CMDIDX) in EISTR. If this bit is set to 0, the Index field of the response is not checked.

Value	Name	Description
0	DISABLE	The Command Index Check is disabled.
1	ENABLE	The Command Index Check is enabled.

#### Bit 3 – CMDCCEN Command CRC Check Enable

If this bit is set to 1, the peripheral checks the CRC field in the response. If an error is detected, it is reported as a Command CRC Error (CMDCRC) in EISTR. If this bit is set to 0, the CRC field is not checked. The position of the CRC field is determined according to the length of the response.

Value	Name	Description
0	DISABLE	The Command CRC Check is disabled.

Value	Name	Description
1	ENABLE	The Command CRC Check is enabled.

**Bits 1:0 – RESPTYP[1:0] Response Type**

This field is set according to the response type expected for the command index (CMDIDX).

Value	Name	Description
0	NONE	No Response
1	136_BIT	Response Length 136
2	48_BIT	Response Length 48
3	48_BIT_BUSY	Response Length 48 with Busy

### 36.7.7 Response Register n

**Name:** RR  
**Offset:** 0x10 + n\*0x04 [n=0..3]  
**Reset:** 0x00000000  
**Property:** -

Bit	31	30	29	28	27	26	25	24
	CMDRESP[31:24]							
Access	R	R	R	R	R	R	R	R
Reset	0	0	0	0	0	0	0	0
Bit	23	22	21	20	19	18	17	16
	CMDRESP[23:16]							
Access	R	R	R	R	R	R	R	R
Reset	0	0	0	0	0	0	0	0
Bit	15	14	13	12	11	10	9	8
	CMDRESP[15:8]							
Access	R	R	R	R	R	R	R	R
Reset	0	0	0	0	0	0	0	0
Bit	7	6	5	4	3	2	1	0
	CMDRESP[7:0]							
Access	R	R	R	R	R	R	R	R
Reset	0	0	0	0	0	0	0	0

#### Bits 31:0 – CMDRESP[31:0] Command Response

The table below describes the mapping of command responses from the SD/SDIO/e.MMC bus to these registers for each responses type. In this table, R[] refers to a bit range of the response data as transmitted on the SD/SDIO/e.MMC bus.

Type of response	Meaning of response	Response field	Response register
R1, R1b (normal response)	Card Status	R[39:8]	RR0[31:0]
R1b (Auto CMD12 response)	Card Status for Auto CMD12	R[39:8]	RR3[31:0]
R1 (Auto CMD23 response)	Card Status for Auto CMD23	R[39:8]	RR3[31:0]
R2 (CID, CSD register)	CID or CSD register	R[127:8]	RR0[31:0] RR1[31:0] RR2[31:0] RR3[23:0]
R3 (OCR register)	OCR register for memory	R[39:8]	RR0[31:0]
R4 (OCR register)	OCR register for I/O	R[39:8]	RR0[31:0]
R5, R5b	SDIO response	R[39:8]	RR0[31:0]
R6 (Published RCA response)	New published RCA[31:16] and Card status bits	R[39:8]	RR0[31:0]

### 36.7.8 Buffer Data Port Register

**Name:** BDPR  
**Offset:** 0x20  
**Reset:** 0x00000000  
**Property:** -

Bit	31	30	29	28	27	26	25	24
	BUFDATA[31:24]							
Access	R/W	R/W	R/W	R/W	R/W	R/W	R/W	R/W
Reset	0	0	0	0	0	0	0	0
Bit	23	22	21	20	19	18	17	16
	BUFDATA[23:16]							
Access	R/W	R/W	R/W	R/W	R/W	R/W	R/W	R/W
Reset	0	0	0	0	0	0	0	0
Bit	15	14	13	12	11	10	9	8
	BUFDATA[15:8]							
Access	R/W	R/W	R/W	R/W	R/W	R/W	R/W	R/W
Reset	0	0	0	0	0	0	0	0
Bit	7	6	5	4	3	2	1	0
	BUFDATA[7:0]							
Access	R/W	R/W	R/W	R/W	R/W	R/W	R/W	R/W
Reset	0	0	0	0	0	0	0	0

#### Bits 31:0 – BUFDATA[31:0] Buffer Data

The peripheral's data buffer can be accessed through this 32-bit Data Port register.



### 36.7.9 Present State Register

**Name:** PSR  
**Offset:** 0x24  
**Reset:** 0x00F80000  
**Property:** -

Bit	31	30	29	28	27	26	25	24
								CMDLL
Access								R
Reset								0
Bit	23	22	21	20	19	18	17	16
	DATLL[3:0]				WRPPL	CARDDPL	CARDSS	CARDINS
Access	R	R	R	R	R	R	R	R
Reset	1	1	1	1	1	0	0	0
Bit	15	14	13	12	11	10	9	8
					BUFRDEN	BUFWREN	RTACT	WTACT
Access					R	R	R	R
Reset					0	0	0	0
Bit	7	6	5	4	3	2	1	0
					RTREQ	DLACT	CMDINHDL	CMDINHCL
Access					R	R	R	R
Reset					0	0	0	0

#### Bit 24 – CMDLL CMD Line Level

This status is used to check the CMD line level to recover from errors, and for debugging.

#### Bits 23:20 – DATLL[3:0] DAT[3:0] Line Level

This status is used to check the DAT line level to recover from errors, and for debugging. This is especially useful in detecting the Busy signal level from DAT[0].

#### Bit 19 – WRPPL Write Protect Pin Level

The Write Protect Switch is supported for memory and combo cards. This bit reflects the WP pin.

Value	Description
0	Write protected (WP = 0)
1	Write enabled (WP = 1)

#### Bit 18 – CARD DPL Card Detect Pin Level

This bit reflects the inverse value of the CD pin. Debouncing is not performed on this bit. This bit may be valid when CARDSS is set to 1, but it is not guaranteed because of the propagation delay. Use of this bit is limited to testing since it must be debounced by software.

Value	Description
0	No card present (CD = 1)
1	Card present (CD = 0)

#### Bit 17 – CARDSS Card State Stable

This bit is used for testing. If it is 0, the CARD DPL is not stable. If this bit is set to 1, it means that the CARD DPL is stable. No Card state can be detected if this bit is set to 1 and CARDINS is set to 0. The Software Reset For All (SWRSTALL) in SRR does not affect this bit.

Value	Description
0	Reset or debouncing

Value	Description
1	No card or card inserted

#### Bit 16 – **CARDINS** Card Inserted

This bit indicates whether a card has been inserted. The peripheral debounces this signal so that the user does not need to wait for it to stabilize.

A change from 0 to 1 rises the Card Insertion (CINS) status flag in NISTR if NISTER.CINS is set to 1. An interrupt is generated if NISIER.CINS is set to 1.

A change from 1 to 0 rises the Card Removal (CREM) status flag in NISTR if NISTER.CREM is set to 1.

An interrupt is generated if NISIER.CREM is set to 1.

The Software Reset For All (SWRSTALL) in SRR does not affect this bit.

#### Bit 11 – **BUFRDEN** Buffer Read Enable

This bit is used for non-DMA read transfers. This flag indicates that valid data exists in the peripheral data buffer. If this bit is 1, readable data exists in the buffer.

A change from 1 to 0 occurs when all the block data is read from the buffer.

A change from 0 to 1 occurs when block data is ready in the buffer. This rises the Buffer Read Ready (BRDRDY) status flag in NISTR if NISTER.BRDRDY is set to 1. An interrupt is generated if NISIER.BRDRDY is set to 1.

#### Bit 10 – **BUFWREN** Buffer Write Enable

This bit is used for non-DMA write transfers. This flag indicates if space is available for write data. If this bit is 1, data can be written to the buffer.

A change from 1 to 0 occurs when all the block data are written to the buffer.

A change from 0 to 1 occurs when top of block data can be written to the buffer. This rises the Buffer Write Ready (BRWRDY) status flag in NISTR if NISTER.BRWRDY is set to 1. An interrupt is generated if NISIER.BRWRDY is set to 1.

#### Bit 9 – **RTACT** Read Transfer Active

This bit is used to detect completion of a read transfer. Refer to section “Read Transaction Wait / Continue Timing” in the “SD Host Controller Simplified Specification V3.00” for more details on the sequence of events.

This bit is set to 1 in either of the following conditions:

- After the end bit of the read command.
- When a read operation is restarted by writing a 1 to BGCR.CONTR (Continue Request).

This bit is cleared to 0 in either of the following conditions:

- When the last data block as specified by Transfer Block Size (BLOCKSIZE) is transferred to the system.
- In case of ADMA2, end of read is designated by the descriptor table.
- When all valid data blocks in the peripheral have been transferred to the system and no current block transfers are being sent as a result of the Stop At Block Gap Request (STPBGR) of BGCR being set to 1.

A change from 1 to 0 rises the Transfer Complete (TRFC) status flag in NISTR if NISTER.TRFC is set to 1. An interrupt is generated if NISIER.TRFC is set to 1.

#### Bit 8 – **WTACT** Write Transfer Active

This bit indicates a write transfer is active. If this bit is 0, it means no valid write data exists in the peripheral. Refer to section “Write Transaction Wait / Continue Timing” in the “SD Host Controller Simplified Specification V3.00” for more details on the sequence of events.

This bit is set to 1 in either of the following conditions:

- After the end bit of the write command.
- When a write operation is restarted by writing a 1 to BGCR.CONTR (Continue Request).

This bit is cleared to 0 in either of the following conditions:

- After getting the CRC status of the last data block as specified by the transfer count (single and multiple). In case of ADMA2, transfer count is designated by the descriptor table.
- After getting the CRC status of any block where a data transmission is about to be stopped by a Stop At Block Gap Request (STPBGR) of BGCR.

During a write transaction and as the result of the Stop At Block Gap Request (STPBGR) being set, a change from 1 to 0 rises the Block Gap Event (BLKGE) status flag in NISTR if NISTER.BLKGE is set to 1. An interrupt is generated if BLKGE is set to 1 in NISIER. This status is useful to determine whether non-DAT line commands can be issued during Write Busy.

### Bit 3 – RTREQ Retuning Request

The peripheral can instruct the software to execute a re-tuning sequence by setting this bit when the data window is shifted by a temperature drift and a tuned sampling point does not have a good margin to receive correct data.

This bit is cleared to 0 when a command is issued by setting Execute Tuning (EXTUN) in HC2R.

A change from 0 to 1 rises the Re-Tuning Event (RTEVT) status flag in NISTR if NISTER.RTEVT is set to 1. An interrupt is generated if NISIER.RTEVT is set to 1.

This bit is not set to 1 if Sampling Clock Select (SCLKSEL) in HC2R is set to 0 (using a fixed sampling clock). Refer to Re-Tuning Modes (RTMODE) in CA1R.

Value	Description
0	Fixed or well-tuned sampling clock
1	Sampling clock needs re-tuning

### Bit 2 – DLACT DAT Line Active

This bit indicates whether one of the DAT lines on the bus is in use.

In the case of read transactions:

This status indicates whether a read transfer is executing on the bus. A change from 1 to 0 resulting from setting the Stop At Block Gap Request (STPBGR) rises the Block Gap Event (BLKGE) status flag in NISTR if NISTER.BLKGE is set to 1. An interrupt is generated if NISIER.BLKGE is set to 1. Refer to section “Read Transaction Wait / Continue Timing” in the “SD Host Controller Simplified Specification V3.00” for details on timing.

This bit is set in either of the following cases:

- After the end bit of the read command.
- When writing 1 to BGCR.CONTR (Continue Request) to restart a read transfer.

This bit is peripheral cleared in either of the following cases:

- When the end bit of the last data block is sent from the bus to the peripheral. In case of ADMA2, the last block is designated by the last transfer of the Descriptor Table.
- When a read transfer is stopped at the block gap initiated by a Stop At Block Gap Request (STPBGR).

The peripheral stops a read operation at the start of the interrupt cycle by driving the Read Wait (DAT[2] line) or by stopping the SD Clock. If the Read Wait signal is already driven (due to the fact that the data buffer cannot receive data), the peripheral can continue to stop the read operation by driving the Read Wait signal. It is necessary to support the Read Wait in order to use the Suspend/Resume operation.

In the case of write transactions:

This status indicates that a write transfer is executing on the bus. A change from 1 to 0 rises the Transfer Complete (TRFC) status flag in NISTR if NISTER.TRFC is set to 1. An interrupt is generated if NISIER.TRFC is set to 1. Refer to section “Write Transaction Wait / Continue Timing” in the “SD Host Controller Simplified Specification V3.00” for details on timing.

This bit is set in either of the following cases:

- After the end bit of the write command.

- When writing 1 to BGCR.CONTR (Continue Request) to continue a write transfer.

This bit is cleared in either of the following cases:

- When the card releases Write Busy of the last data block. If the card does not drive a Busy signal for 8 SDCLK, the peripheral considers the card drive "Not Busy". In the case of ADMA2, the last block is designated by the last transfer of the Descriptor Table.
- When the card releases Write Busy prior to wait for write transfer as a result of a Stop At Block Gap Request (STPBGR).

Command with Busy:

This status indicates whether a command that indicates Busy (ex. erase command for memory) is executing on the bus. This bit is set to 1 after the end bit of the command with Busy and cleared when Busy is de-asserted. A change from 1 to 0 rises the Transfer Complete (TRFC) status flag in NISTR if NISTER.TRFC is set to 1. An interrupt is generated if NISIER.TRFC is set to 1. Refer to Figures 2.11 to 2.13 in the "SD Host Controller Simplified Specification V3.00".

Value	Description
0	DAT Line Inactive
1	DAT Line Active

#### Bit 1 – CMDINH Command Inhibit (DAT)

This status bit is 1 if either the DAT Line Active (DLACT) or the Read Transfer Active (RTACT) is set to 1. If this bit is 0, it indicates that the peripheral can issue the next command. Commands with a Busy signal belong to Command Inhibit (DAT) (ex. R1b, R5b type). A change from 1 to 0 rises the Transfer Complete (TRFC) status flag in NISTR if NISTER.TRFC is set to 1. An interrupt is generated if NISIER.TRFC is set to 1.

Note: The software can save registers in the 000-00Dh range for a suspend transaction after this bit has changed from 1 to 0.

Value	Description
0	Can issue a command which uses the DAT line(s).
1	Cannot issue a command which uses the DAT line(s).

#### Bit 0 – CMDINH Command Inhibit (CMD)

If this bit is 0, it indicates the CMD line is not in use and the peripheral can issue a command using the CMD line. This bit is set to 1 immediately after CR is written. This bit is cleared when the command response is received. Auto CMD12 and Auto CMD23 consist of two responses. In this case, this bit is not cleared by the CMD12 or CMD23 response, but by the Read/Write command response. Status issuing Auto CMD12 is not read from this bit. So, if a command is issued during Auto CMD12 operation, the peripheral manages to issue both commands: CMD12 and a command set by CR. Even if the Command Inhibit (DAT) is set to 1, commands using only the CMD line can be issued if this bit is 0.

A change from 1 to 0 rises the Command Complete (CMDC) status flag in NISTR if NISTER.CMDC is set to 1. An interrupt is generated if NISIER.CMDC is set to 1.

If the peripheral cannot issue the command because of a command conflict error (refer to CMDCRC in EISTR) or because of a 'Command Not Issued By Auto CMD12' error (refer to [Section 1.2.31 "SDMMC Auto CMD Error Status Register"](#)), this bit remains 1 and Command Complete is not set.

Value	Description
0	Can issue a command using only CMD line.
1	Cannot issue a command.

### 36.7.10 Host Control 1 Register

**Name:** HC1R  
**Offset:** 0x28  
**Reset:** 0x00  
**Property:** -

Bit	7	6	5	4	3	2	1	0
	CARDDSEL	CARDDTL		DMASEL[1:0]		HSEN	DW	LEDCTRL
Access	R/W	R/W		-	-	R/W	R/W	R/W
Reset	0	0		0	0	0	0	0

#### Bit 7 – CARDDSEL Card Detect Signal Selection

**Note:** This register entry is specific to the SD/SDIO operation mode.

This bit selects the source for the card detection.

Value	Description
0	The CD pin is selected.
1	The Card Detect Test Level (CARDDTL) is selected (for test purpose).

#### Bit 6 – CARDDTL Card Detect Test Level

**Note:** This register entry is specific to the SD/SDIO operation mode.

This bit is enabled while the Card Detect Signal Selection (CARDDSEL) is set to 1 and it indicates whether the card is inserted or not.

Value	Description
0	No card.
1	Card inserted.

#### Bits 4:3 – DMASEL[1:0] DMA Select

One of the supported DAM modes can be selected. The user must check support of DMA modes by referring the CA0R. Use of selected DMA is determined by DMA Enable (DMAEN) in TMR.

Value	Name	Description
0	SDMA	SDMA is selected
1	Reserved	Reserved
2	32BIT	32-bit Address ADMA2 is selected
3	Reserved	Reserved

#### Bit 2 – HSEN High Speed Enable

Before setting this bit, the user must check the High Speed Support (HSSUP) in CA0R.

If this bit is set to 0 (default), the peripheral outputs CMD line and DAT lines at the falling edge of the SD clock (up to 25 MHz). If this bit is set to 1, the SDMMC outputs the CMD line and the DAT lines at the rising edge of the SD clock (up to 50 MHz).

If Preset Value Enable (PVALEN) in HC2R is set to 1, the user needs to reset SD Clock Enable (SDCLKEN) before changing this bit to avoid generating clock glitches. After setting this bit to 1, the user sets SDCLLEN to 1 again.

Value	Description
0	Normal Speed mode.
1	High Speed mode. Note: 1. This bit is effective only if MC1R.DDR is set to 0. 2. The clock divider (DIV) in CCR must be set to a value different from 0 when HSEN is 1.

#### Bit 1 – DW Data Width

This bit selects the data width of the peripheral. It must be set to match the data width of the card.

**Note:** If the Extended Data Transfer Width is 1, this bit has no effect and the data width is 8-bit mode.

Value	Name	Description
0	1BIT	1-bit mode
1	4BIT	4-bit mode

**Bit 0 - LEDCTRL** LED Control

**Note:** This register entry is specific to the SD/SDIO operation mode.

This bit is used to caution the user not to remove the card while it is being accessed. If the software is going to issue multiple commands, this bit is set to 1 during all transactions.

Value	Name	Description
0	OFF	LED off
1	ON	LED on

### 36.7.11 Power Control Register

**Name:** PCR  
**Offset:** 0x29  
**Reset:** 0x0E  
**Property:** -

Bit	7	6	5	4	3	2	1	0
					SDBVSEL[2:0]			SDBPWR
Access					R/W	R/W	R/W	R/W
Reset					1	1	1	0

#### Bits 3:1 – SDBVSEL[2:0] SD Bus Voltage Select

By setting this bit, the user selects the voltage level for the card. Before setting this register, the user must check the Voltage Support in CA0R. If an unsupported voltage is selected, the system does not supply the bus voltage.

Value	Name	Description
0x0–0x4	Reserved	Reserved
0x5	1V8	1.8 Volt (Typical)
0x6	3V0	3.0 Volt (Typical)
0x7	3V3	3.3 Volt (Typical)

#### Bit 0 – SDBPWR SD Bus Power

This bit is automatically cleared by the peripheral if the card is removed. If this bit is cleared, the peripheral stops driving CMD and DAT[7:0] (tri-state) and drives CK to low level.

### 36.7.12 Block Gap Control Register

**Name:** BGCR  
**Offset:** 0x2A  
**Reset:** 0x00  
**Property:** -

Bit	7	6	5	4	3	2	1	0
					INTBG	RWCTRL	CONTR	STPBGR
Access					R/W	R/W	R/W	R/W
Reset					0	0	0	0

#### Bit 3 – INTBG Interrupt at Block Gap

**Note:** This register entry is specific to the SD/SDIO operation mode.

This bit is valid only in 4-bit mode of the SDIO card and selects a sample point in the interrupt cycle. Setting to 1 enables interrupt detection at the block gap for a multiple block transfer. If the SDIO card cannot signal an interrupt during a multiple block transfer, this bit should be set to 0. When the software detects an SDIO card insertion, it sets this bit according to the CCCR of the SDIO card.

Value	Name	Description
0	DISABLED	Interrupt detection disabled
1	ENABLED	Interrupt detection enabled

#### Bit 2 – RWCTRL Read Wait Control

**Note:** This register entry is specific to the SD/SDIO operation mode.

The Read Wait control is optional for SDIO cards. If the card supports Read Wait, set this bit to enable use of the Read Wait protocol to stop read data using the DAT[2] line. Otherwise, the peripheral stops the SDCLK to hold read data, which restricts command generation. When the software detects an SD card insertion, this bit must be set according to the CCCR of the SDIO card. If the card does not support Read Wait, this bit shall never be set to 1, otherwise an DAT line conflict may occur. If this bit is set to 0, Suspend/Resume cannot be supported.

Value	Description
0	Disables Read Wait control.
1	Enables Read Wait control.

#### Bit 1 – CONTR Continue Request

This bit is used to restart a transaction which was stopped using a Stop At Block Gap Request (STPBGR). To cancel stop at the block gap, set STPBGR to 0 and set this bit to 1 to restart the transfer. The peripheral automatically clears this bit in either of the following cases:

- In the case of a read transaction, the DAT Line Active (DLACT) changes from 0 to 1 as a read transaction restarts.
- In the case of a write transaction, the Write Transfer Active (WTACT) changes from 0 to 1 as the write transaction restarts.

Therefore, it is not necessary to set this bit to 0. If STPBGR is set to 1, any write to this bit is ignored. Refer to the “Abort Transaction” and “Suspend/Resume” sections in the “SD Host Controller Simplified Specification V3.00” for more details.

Value	Description
0	No affect
1	Restart

#### Bit 0 – STPBGR Stop At Block Gap Request

This bit is used to stop executing read and write transactions at the next block gap for non-DMA, SDMA, and ADMA transfers. The user must leave this bit set to 1 until Transfer Complete (TRFC)



in NISTR. Clearing both Stop At Block Gap Request and Continue Request does not cause the transaction to restart. This bit can be set whether the card supports the Read Wait signal or not. During read transfers, the peripheral stops the transaction by using the Read Wait signal (DAT[2]) if supported, or by stopping the SD clock otherwise.

In case of write transfers in which the user writes data to BDPR, this bit must be set to 1 after all the block of data is written. If this bit is set to 1, the user does not write data to BDPR.

This bit affects Read Transfer Active (RTACT), Write Transfer Active (WTACT), DAT Line Active (DLACT) and Command Inhibit (DAT) (CMDINH) in PSR.

Refer to the "Abort Transaction" and "Suspend/Resume" sections in the "SD Host Controller Simplified Specification V3.00" for more details.

Value	Description
0	Transfer
1	Stop

### 36.7.13 Wakeup Control Register: SD/SDIO

**Name:** WCR  
**Offset:** 0x2B  
**Reset:** 0x00  
**Property:** -

Bit	7	6	5	4	3	2	1	0
						WKENCREM	WKENCINS	WKENCINT
Access						R/W	R/W	R/W
Reset						0	0	0

#### Bit 2 – WKENCREM Wake-up Event Enable on Card Removal

This bit enables a wake-up event via Card Removal (CREM) in NISTR. FN\_WUS (Wake-Up Support) in the CIS (Card Information Structure) does not affect this bit.

Value	Name	Description
0	DISABLE	Wake-Up Event disabled
1	ENABLE	Wake-Up Event enabled

#### Bit 1 – WKENCINS Wake-Up Event Enable on Card Insertion

This bit enables a wake-up event via Card Insertion (CINS) in NISTR. FN\_WUS (Wake-Up Support) in the CIS (Card Information Structure) does not affect this bit.

Value	Name	Description
0	DISABLE	Wake-Up Event disabled
1	ENABLE	Wake-Up Event enabled

#### Bit 0 – WKENCINT Wake-Up Event Enable on Card Interrupt

This bit enables a wake-up event via Card Interrupt (CINT) in NISTR. This bit can be set to 1 if FN\_WUS (Wake-Up Support) in the CIS (Card Information Structure) is set to 1 in the SDIO card.

Value	Name	Description
0	DISABLE	Wake-Up Event disabled
1	ENABLE	Wake-Up Event enabled

### 36.7.14 Clock Control Register

**Name:** CCR  
**Offset:** 0x2C  
**Reset:** 0x0000  
**Property:** -

Bit	15	14	13	12	11	10	9	8
	SDCLKFSEL[7:0]							
Access	R/W	R/W	R/W	R/W	R/W	R/W	R/W	R/W
Reset	0	0	0	0	0	0	0	0
Bit	7	6	5	4	3	2	1	0
	USDCLKFSEL[1:0]		CLKGSEL			SDCLKEN	INTCLKS	INTCLKEN
Access	R/W	R/W	R/W			R/W	R/W	R/W
Reset	0	0	0			0	0	0

#### Bits 15:8 – SDCLKFSEL[7:0] SDCLK Frequency Select

This register is used to select the frequency of the SDCLK pin. There are two SDCLK Frequency modes according to Clock Generator Select (CLKGSEL).

The length of the clock divider (DIV) is extended to 10 bits (DIV[9:8] = USDCLKFSEL, DIV[7:0] = SDCLKFSEL)

– 10-bit Divided Clock Mode (CLKGSEL = 0):

$$F_{SDCLK} = F_{BASECLK} / (2 \times DIV)$$

. If DIV = 0 then

$$F_{SDCLK} = F_{BASECLK}$$

– Programmable Clock Mode (CLKGSEL = 1):

$$F_{SDCLK} = F_{MULTCLK} / (DIV + 1)$$

This field depends on the setting of Preset Value Enable (PVALEN) in HC2R.

If HC2R.PVALEN = 0, this field is set by the user.

If HC2R.PVALEN = 1, this field is automatically set to a value specified in one of the PVR.

#### Bits 7:6 – USDCLKFSEL[1:0] Upper Bits of SDCLK Frequency Select

These bits expand the SDCLK Frequency Select (SDCLKFSEL) to 10 bits. These two bits are assigned to bit 09-08 of the clock divider as described in SDCLKFSEL.

#### Bit 5 – CLKGSEL Clock Generator Select

This bit is used to select the clock generator mode in the SDCLK Frequency Select field. If the Programmable mode is not supported (CA1R.CLKMULT (Clock Multiplier) set to 0), then this bit cannot be written and is always read at 0.

This bit depends on the setting of Preset Value Enable (PVALEN) in HC2R.

If HC2R.PVALEN = 0, this bit is set by the user.

If HC2R.PVALEN = 1, this bit is automatically set to a value specified in one of the PVRx.

Value	Description
0	Divided Clock mode (BASECLK is used to generate SDCLK).
1	Programmable Clock mode (MULTCLK is used to generate SDCLK).

#### Bit 2 – SDCLKEN SD Clock Enable

The peripheral stops the SD Clock when writing this bit to 0. SDCLK Frequency Select (SDCLKFSEL) can be changed when this bit is 0. Then, the peripheral maintains the same clock frequency until SDCLK is stopped (Stop at SDCLK=0). If Card Inserted (CARDINS) in PSR is cleared, this bit is also cleared.

Value	Description
0	SD Clock disabled
1	SD Clock enabled

**Bit 1 – INTCLKS** Internal Clock Stable

This bit is set to 1 when the SD clock is stable after setting CCR.INTCLKEN (Internal Clock Enable) to 1. The user must wait to set SD Clock Enable (SDCLKEN) until this bit is set to 1.

Value	Description
0	Internal clock not ready
1	Internal clock ready

**Bit 0 – INTCLKEN** Internal Clock Enable

This bit is set to 0 when the peripheral is not used or is awaiting a wakeup interrupt. In this case, its internal clock is stopped to reach a very low power state. Registers are still able to be read and written. The clock starts to oscillate when this bit is set to 1. Once the clock oscillation is stable, the peripheral sets Internal Clock Stable (INTCLKS) in this register to 1.

This bit does not affect card detection.

Value	Description
0	The internal clock stops.
1	The internal clock oscillates.

### 36.7.15 Timeout Control Register

**Name:** TCR  
**Offset:** 0x2E  
**Reset:** 0x00  
**Property:** -

Bit	7	6	5	4	3	2	1	0
					DTCVAL[3:0]			
Access					R/W	R/W	R/W	R/W
Reset					0	0	0	0

#### Bits 3:0 – DTCVAL[3:0] Data Timeout Counter Value

This value determines the interval at which DAT line timeouts are detected. For more information about timeout generation, refer to Data Timeout Error (DATTEO) in EISTR. When setting this register, the user can prevent inadvertent timeout events by clearing the Data Timeout Error Status Enable (in EISTER).

$$\text{TIMEOUT}_{(\mu\text{S})} = \frac{2^{13 + \text{DTCVAL}}}{F_{\text{BASECLK(MHz)}}$$

Note: DTCVAL = F<sub>(Hexa)</sub> is reserved.

### 36.7.16 Software Reset Register

**Name:** SRR  
**Offset:** 0x2F  
**Reset:** 0x00  
**Property:** -

Bit	7	6	5	4	3	2	1	0
						SWRSTDAT	SWRSTCMD	SWRSTALL
Access						R/W	R/W	R/W
Reset						0	0	0

#### Bit 2 – SWRSTDAT Software reset for DAT line

Only part of a data circuit is reset. The DMA circuit is also reset.  
The following registers and bits are cleared by this bit:

- Buffer Data Port Register [36.7.8. BDPR](#): BUFDATA is cleared and initialized.
- Present State Register [36.7.9. PSR](#):
  - Buffer Read Enable (BUFRDEN)
  - Buffer Write Enable (BUFWREN)
  - Read Transfer Active (RTACT)
  - Write Transfer Active (WTACT)
  - DAT Line Active (DATLL)
  - Command Inhibit - DAT (CMDINH)
- Block Gap Control Register [36.7.12. BGCR](#):
  - Continue Request (CONTR)
  - Stop At Block Gap Request (STPBGR)
- Normal Interrupt Status Register [36.7.17. NISTR](#):
  - Buffer Read Ready (BRDRDY)
  - Buffer Write Ready (BWRRDY)
  - DMA Interrupt (DMAINT)
  - Block Gap Event (BLKGE)
  - Transfer Complete (TRFC)

Value	Description
0	Work
1	Reset

#### Bit 1 – SWRSTCMD Software reset for CMD line

Only part of a command circuit is reset.  
The following registers and bits are cleared by this bit:

- Present State Register [36.7.9. PSR](#):
  - Command Inhibit (CMD) (CMDINHC)
- Normal Interrupt Status Register [36.7.17. NISTR](#):
  - Command Complete (CMDC)

Value	Description
0	Work
1	Reset

**Bit 0 – SWRSTALL** Software reset for All

This reset affects the entire peripheral except the card detection circuit. During initialization, the peripheral must be reset by setting this bit to 1. This bit is automatically cleared to 0 when CA0R and CA1R are valid and the user can read them. If this bit is set to 1, the user should issue a reset command and reinitialize the card.

List of registers cleared to 0:

- SDMA System Address / Argument 2 Register [36.7.1. SSAR](#)
- Block Size Register [36.7.2. BSR](#)
- Block Count Register [36.7.3. BCR](#)
- Argument 1 Register [36.7.4. ARG1R](#)
- Transfer Mode Register [36.7.5. TMR](#)
- Command Register [36.7.6. CR](#)
- Response Register n [36.7.7. RR](#)
- Buffer Data Port Register [36.7.8. BDPR](#)
- Present State Register [36.7.9. PSR](#) (except CMDLL, DATLL, WRPPL, CARDDDPL, CARDSS, CARDINS)
- Host Control 1 Register [36.7.10. HC1R](#)
- Power Control Register [36.7.11. PCR](#)
- Block Gap Control Register [36.7.12. BGCR](#)
- Wakeup Control Register [36.7.13. WCR](#)
- Clock Control Register [36.7.14. CCR](#)
- Timeout Control Register [36.7.15. TCR](#)
- Normal Interrupt Status Register [36.7.17. NISTR](#)
- Error Interrupt Status Register [36.7.18. EISTR](#)
- Normal Interrupt Status Enable Register [36.7.19. NISTER](#)
- Error Interrupt Status Enable Register [36.7.20. EISTER](#)
- Normal Interrupt Signal Enable Register [36.7.21. NISIER](#)
- Error Interrupt Signal Enable Register [36.7.22. EISIER](#)
- Auto CMD Error Status Register [36.7.23. ACESR](#)
- Host Control 2 Register [36.7.25. HC2R - DEFAULT](#)
- ADMA Error Status Register [36.7.31. AESR](#)
- ADMA System Address Registers
- Slot Interrupt Status Register [36.7.34. SISR](#)
- e.MMC Control 1 Register [36.7.37. MC1R](#)
- e.MMC Control 2 Register [36.7.38. MC2R](#)
- AHB Control Register [36.7.39. ACR](#)
- Clock Control 2 Register [36.7.40. CC2R](#)
- Capabilities Control Register [36.7.41. CACR](#) (except KEY)

Value	Description
0	Work
1	Reset

### 36.7.17 Normal Interrupt Status Register

**Name:** NISTR  
**Offset:** 0x30  
**Reset:** 0x0000  
**Property:** -

Bit	15	14	13	12	11	10	9	8
	ERRINT	BOOTAR						CINT
Access	R/W	R/W						R/W
Reset	0	0						0
Bit	7	6	5	4	3	2	1	0
	CREM	CINS	BRDRDY	BWRRDY	DMAINT	BLKGE	TRFC	CMDC
Access	R/W	R/W	R/W	R/W	R/W	R/W	R/W	R/W
Reset	0	0	0	0	0	0	0	0

#### Bit 15 – ERRINT Error Interrupt

If any of the bits in EISTR are set, then this bit is set. Therefore, the user can efficiently test for an error by checking this bit first. This bit is read-only.

Value	Description
0	No error
1	Error

#### Bit 14 – BOOTAR Boot Acknowledge Received

**Note:** This register entry is specific to the e.MMC operation mode.

This bit is set to 1 when the peripheral received a Boot Acknowledge pattern from the e.MMC. This bit can only be set to 1 if NISTER.BOOTAR is set to 1. An interrupt can only be generated if NISIER.BOOTAR is set to 1.

Writing this bit to 1 clears this bit.

Value	Description
0	Boot Acknowledge pattern not received.
1	Boot Acknowledge pattern received.

#### Bit 8 – CINT Card Interrupt

**Note:** This register entry is specific to the SD/SDIO operation mode.

Writing this bit to 1 does not clear this bit. It is cleared by resetting the SD card interrupt factor. In 1-bit mode, the peripheral detects the Card Interrupt without SDCLK to support wake-up. In 4-bit mode, the Card Interrupt signal is sampled during the interrupt cycle, so there are some sample delays between the interrupt signal from the SD card and the interrupt to the system.

When this bit has been set to 1 and the user needs to start this interrupt service, Card Interrupt Status Enable (CINT) in NISTER may be set to 0 in order to clear the card interrupt statuses latched in the peripheral and to stop driving the interrupt signal to the system. After completion of the card interrupt service (it should reset interrupt factors in the SD card and the interrupt signal may not be asserted), set NISTER.CINT to 1 and start sampling the interrupt signal again.

Interrupt detected by DAT[1] is supported when there is one card per slot. In case of a shared bus, interrupt pins are used to detect interrupts. If 0 is set to Interrupt Pin Select (INTPSEL) in SBCR, this status is effective. If a non-zero value is set to INTPSEL, INT\_A, INT\_B or INT\_C is used as device interrupts.

This bit can only be set to 1 if NISTER.CREM is set to 1. An interrupt can only be generated if NISIER.CREM is set to 1.

Value	Description
0	No card interrupt



Value	Description
1	Card interrupt

#### Bit 7 – CREM Card Removal

**Note:** This register entry is specific to the SD/SDIO operation mode.

This status is set to 1 if Card Inserted (CARDINS) in PSR changes from 1 to 0. When the user writes this bit to 1 to clear this status, the status of PSR.CARDINS must be confirmed because the card detect state may possibly be changed when the user clears this bit and no interrupt event can be generated.

This bit can only be set to 1 if NISTER.CREM is set to 1. An interrupt can only be generated if NISIER.CREM is set to 1.

Writing this bit to 1 clears this bit.

Value	Description
0	Card state unstable or card inserted
1	Card removed

#### Bit 6 – CINS Card Insertion

**Note:** This register entry is specific to the SD/SDIO operation mode.

This status is set if Card Inserted (CARDINS) in PSR changes from 0 to 1. When the user writes this bit to 1 to clear this status, the status of PSR.CARDINS must be confirmed because the card detect state may possibly be changed when the user clears this bit and no interrupt event can be generated.

This bit can only be set to 1 if NISTER.CINS is set to 1. An interrupt can only be generated if NISIER.CINS is set to 1.

Writing this bit to 1 clears this bit.

Value	Description
0	Card state unstable or card removed
1	Card inserted

#### Bit 5 – BRDRDY Buffer Read Ready

This status is set to 1 if the Buffer Read Enable (BUFRDEN) changes from 0 to 1. Refer to BUFRDEN in PSR.

This bit can only be set to 1 if NISTER.BRDRDY is set to 1. An interrupt can only be generated if NISIER.BRDRDY is set to 1.

Writing this bit to 1 clears this bit.

Value	Description
0	Not ready to read buffer
1	Ready to read buffer

#### Bit 4 – BWRRDY Buffer Write Ready

This status is set to 1 if the Buffer Write Enable (BUFWREN) changes from 0 to 1. Refer to BUFWREN in PSR.

This bit can only be set to 1 if NISTER.BWRRDY is set to 1. An interrupt can only be generated if NISIER.BWRRDY is set to 1.

Writing this bit to 1 clears this bit.

Value	Description
0	Not ready to write buffer
1	Ready to write buffer

#### Bit 3 – DMAINT DMA Interrupt

This status is set if the peripheral detects the Host SDMA Buffer boundary during transfer. Refer to SDMA Buffer Boundary (BOUNDARY) in BSR.

In case of ADMA, by setting the “int” field in the descriptor table, the peripheral rises this status flag when the descriptor line is completed. This status flag does not rise after Transfer Complete (TRFC).

This bit can only be set to 1 if NISTER.DMAINT is set to 1. An interrupt can only be generated if NISIER.DMAINT is set to 1.

Writing this bit to 1 clears this bit.

Value	Description
0	No DMA Interrupt
1	DMA Interrupt

### Bit 2 – BLKGE Block Gap Event

If the Stop At Block Gap Request (STPBGR) in BGCR is set to 1, this bit is set when either a read or a write transaction is stopped at a block gap. If STPBGR is not set to 1, this bit is not set to 1.

In the case of a Read transaction:

This bit is set at the falling edge of the DAT Line Active (DLACT) status (when the transaction is stopped at SD bus timing). The Read Wait must be supported in order to use this function. Refer to section “Read Transaction Wait / Continue Timing” in the “SD Host Controller Simplified Specification V3.00” about the detailed timing.

In the case of a Write transaction:

This bit is set at the falling edge of the Write Transfer Active (WTACT) status (after getting the CRC status at SD bus timing). Refer to section “Write Transaction Wait / Continue Timing” in the “SD Host Controller Simplified Specification V3.00” for more details on the sequence of events.

This bit can only be set to 1 if NISTER.BLKGE is set to 1. An interrupt can only be generated if NISIER.BLKGE is set to 1.

Writing this bit to 1 clears this bit.

Value	Description
0	No block gap event
1	Transaction stopped at block gap

### Bit 1 – TRFC Transfer Complete

This bit is set when a read/write transfer and a command with Busy is completed.

In the case of a Read Transaction:

This bit is set at the falling edge of the Read Transfer Active Status. The interrupt is generated in two cases. The first is when a data transfer is completed as specified by the data length (after the last data has been read to the system). The second is when data has stopped at the block gap and completed the data transfer by setting the Stop At Block Gap Request (STPBGR) in BGCR (after valid data has been read to the system). Refer to section “Read Transaction Wait / Continue Timing” in the “SD Host Controller Simplified Specification V3.00” for more details on the sequence of events.

In the case of a Write Transaction:

This bit is set at the falling edge of the DAT Line Active (DLACT) status. This interrupt is generated in two cases. The first is when the last data is written to the card as specified by the data length and the Busy signal is released. The second is when data transfers are stopped at the block gap by setting Stop At Block Gap Request (STPBGR) in BGCR and data transfers are completed. (After valid data is written to the card and the Busy signal is released). Refer to section “Write Transaction Wait / Continue Timing” in the “SD Host Controller Simplified Specification V3.00” for more details on the sequence of events.

In the case of command with Busy:

This bit is set when Busy is de-asserted. Refer to DAT Line Active (DLACT) and Command Inhibit (DAT) (CMDINH) in PSR.

This bit can only be set to 1 if NISTER.TRFC is set to 1. An interrupt can only be generated if NISIER.TRFC is set to 1.

Writing this bit to 1 clears this bit.

The table below shows that Transfer Complete (TRFC) has a higher priority than Data Timeout Error (DATTEO). If both bits are set to 1, execution of a command can be considered to be completed.

TRFC	DATTEO	Meaning of the status
0	0	Interrupted by another factor
0	1	Timeout occurred during transfer
1	Don't Care	Command execution complete

Value	Description
0	Command execution is not complete.
1	Command execution is complete.

#### Bit 0 - CMDC Command Complete

This bit is set when getting the end bit of the command response. Auto CMD12 and Auto CMD23 consist of two responses. Command Complete is not generated by the response of CMD12 or CMD23, but it is generated by the response of a read/write command. Refer to Command Inhibit (CMD) in PSR for details on how to control this bit.

This bit can only be set to 1 if NISTER.CMDC is set to 1. An interrupt can only be generated if NISIER.CMDC is set to 1.

Writing this bit to 1 clears this bit.

The table below shows that Command Timeout Error (CMDTEO) has a higher priority than Command Complete (CMDC). If both bits are set to 1, it can be considered that the response was not received correctly.

CMDC	CMDTEO	Meaning of the status
0	0	Interrupted by another factor
Don't care	1	Response not received within 64 SDCLK cycles
1	0	Response received

Value	Description
0	No command complete
1	Command complete

### 36.7.18 Error Interrupt Status Register

**Name:** EISTR  
**Offset:** 0x32  
**Reset:** 0x0000  
**Property:** -

Bit	15	14	13	12	11	10	9	8
				BOOTAE			ADMA	ACMD
Access				R/W			R/W	R/W
Reset				0			0	0
Bit	7	6	5	4	3	2	1	0
	CURLIM	DATEND	DATCRC	DATTEO	CMDIDX	CMDEND	CMDCRC	CMDTEO
Access	R/W	R/W	R/W	R/W	R/W	R/W	R/W	R/W
Reset	0	0	0	0	0	0	0	0

#### Bit 12 – BOOTAE Boot Acknowledge Error

**Note:** This register entry is specific to the e.MMC operation mode.

This bit is set to 1 when detecting that the e.MMC Boot Acknowledge Status has a value other than “010”.

This bit can only be set to 1 if EISTER.BOOTAE is set to 1. An interrupt can only be generated if EISIER.BOOTAE is set to 1.

Writing this bit to 1 clears this bit.

Value	Description
0	No error
1	Error

#### Bit 9 – ADMA ADMA Error

This bit is set to 1 when the peripheral detects errors during an ADMA-based data transfer. The state of the ADMA at an error occurrence is saved in AESR.

In addition, the peripheral rises this status bit when it detects some invalid description data (Valid=0) at the ST\_FDS state (refer to section “Advanced DMA” in the “SD Host Controller Simplified Specification V3.00”. ADMA Error Status (ERRST) in AESR indicates that an error occurs in ST\_FDS state. The user may find that the Valid bit is not set at the error descriptor.

This bit can only be set to 1 if EISTER.ADMA is set to 1. An interrupt can only be generated if EISIER.ADMA is set to 1.

Writing this bit to 1 clears this bit.

Value	Description
0	No error
1	Error

#### Bit 8 – ACMD Auto CMD Error

Auto CMD12 and Auto CMD23 use this error status. This bit is set to 1 when detecting that one of the 0 to 4 bits in AESR (ACESR[4:0]) has changed from 0 to 1. In the case of Auto CMD12, this bit is set to 1, not only when errors occur in Auto CMD12, but also when Auto CMD12 is not executed due to the previous command error.

This bit can only be set to 1 if EISTER.ACMD is set to 1. An interrupt can only be generated if EISIER.ACMD is set to 1.

Writing this bit to 1 clears this bit.

Value	Description
0	No error
1	Error

**Bit 7 – CURLIM** Current Limit Error

By setting SD Bus Power (SDBPWR) in PCR, the peripheral is requested to supply power for the SD Bus. The peripheral is protected from an illegal card by stopping power supply to the card, in which case this bit indicates a failure status. Reading 1 means the peripheral is not supplying power to the card due to some failure. Reading 0 means that the peripheral is supplying power and no error has occurred. The peripheral may require some sampling time to detect the current limit.

This bit can only be set to 1 if EISTER.CURLIM is set to 1. An interrupt can only be generated if EISIER.CURLIM is set to 1.

Writing this bit to 1 clears this bit.

Value	Description
0	No error
1	Error

**Bit 6 – DATEND** Data End Bit Error

This bit is set to 1 either when detecting 0 at the end bit position of read data which uses the DAT line or at the end bit position of the CRC Status.

This bit can only be set to 1 if EISTER.DATEND is set to 1. An interrupt can only be generated if EISIER.DATEND is set to 1.

Writing this bit to 1 clears this bit.

Value	Description
0	No error
1	Error

**Bit 5 – DATCRC** Data CRC Error

This bit is set to 1 when detecting a CRC error during a transfer of read data which uses the DAT line or when detecting that the Write CRC Status has a value other than '010'.

This bit can only be set to 1 if EISTER.DATCRC is set to 1. An interrupt can only be generated if EISIER.DATCRC is set to 1.

Writing this bit to 1 clears this bit.

Value	Description
0	No error
1	Error

**Bit 4 – DATTEO** Data Timeout error

This bit is set to 1 when detecting one of following timeout conditions:

- Busy timeout for R1b, R5b response type (see “Physical Layer Simplified Specification V3.01” and “SDIO Simplified Specification V3.00” ).
- Busy timeout after Write CRC Status.
- Write CRC Status timeout.
- Read data timeout.

This bit can only be set to 1 if EISTER.DATTEO is set to 1. An interrupt can only be generated if EISIER.DATTEO is set to 1.

Writing this bit to 1 clears this bit.

Value	Description
0	No error
1	Error

**Bit 3 – CMDIDX** Command Index Error

This bit is set to 1 if a Command Index error occurs in the command response.

This bit can only be set to 1 if EISTER.CMDIDX is set to 1. An interrupt can only be generated if EISIER.CMDIDX is set to 1.

Writing this bit to 1 clears this bit.

Value	Description
0	No error

Value	Description
1	Error

**Bit 2 – CMDEND** Command End Bit Error

This bit is set to 1 when detecting that the end bit of a command response is 0. This bit can only be set to 1 if EISTER.CMDEND is set to 1. An interrupt can only be generated if EISIER.CMDEND is set to 1. Writing this bit to 1 clears this bit.

Value	Description
0	No error
1	Error

**Bit 1 – CMDCRC** Command CRC Error

The Command CRC Error is generated in two cases. If a response is returned and Command Timeout Error (CMDTEO) is set to 0 (indicating no command timeout), this bit is set to 1 when detecting a CRC error in the command response. The peripheral detects a CMD line conflict by monitoring the CMD line when a command is issued. If the peripheral drives the CMD line to 1 level, but detects 0 level on the CMD line at the next SDCLK edge, then the peripheral aborts the command (stops driving the CMD line) and sets this bit to 1. CMDTEO is also set to 1 to indicate a CMD line conflict (refer to [Table 36-2](#)). This bit can only be set to 1 if EISTER.CMDCRC is set to 1. An interrupt can only be generated if EISIER.CMDCRC is set to 1. Writing this bit to 1 clears this bit.

**Bit 0 – CMDTEO** Command Timeout Error

This bit is set to 1 only if no response is returned within 64 SDCLK cycles from the end bit of the command. If the peripheral detects a CMD line conflict, in which case Command CRC Error (CMDCRC) is also set to 1, this bit is set without waiting for 64 SDCLK cycles because the command is aborted by the peripheral. This bit can only be set to 1 if EISTER.CMDTEO is set to 1. An interrupt can only be generated if EISIER.CMDTEO is set to 1. Writing this bit to 1 clears this bit.

**Table 36-2.** CMD Error Types

CMDCRC	CMDTEO	Types of error
0	0	No error
0	1	Response timeout error
1	0	Response CRC error
1	1	CMD line conflict

### 36.7.19 Normal Interrupt Status Enable Register: e.MMC

**Name:** NISTER  
**Offset:** 0x34  
**Reset:** 0x0000  
**Property:** -

Bit	15	14	13	12	11	10	9	8
		BOOTAR						CINT
Access		R/W						R/W
Reset		0						0
Bit	7	6	5	4	3	2	1	0
	CREM	CINS	BRDRDY	BWRRDY	DMAINT	BLKGE	TRFC	CMDC
Access	R/W	R/W	R/W	R/W	R/W	R/W	R/W	R/W
Reset	0	0	0	0	0	0	0	0

#### Bit 14 – BOOTAR Boot Acknowledge Received Status Enable

**Note:** This register entry is specific to the e.MMC operation mode.

Value	Name	Description
0	MASKED	The BOOTAR status flag in NISTR is masked.
1	ENABLED	The BOOTAR status flag in NISTR is enabled.

#### Bit 8 – CINT Card Interrupt Status Enable

If this bit is set to 0, the peripheral clears interrupt requests to the system. The Card Interrupt detection is stopped when this bit is cleared and restarted when this bit is set to 1. The user may clear this bit before servicing the Card Interrupt and may set this bit again after all interrupt requests from the card are cleared to prevent inadvertent interrupts.

Value	Name	Description
0	MASKED	The CINT status flag in NISTR is masked.
1	ENABLED	The CINT status flag in NISTR is enabled.

#### Bit 7 – CREM Card Removal Status Enable

Value	Name	Description
0	MASKED	The CREM status flag in NISTR is masked.
1	ENABLED	The CREM status flag in NISTR is enabled.

#### Bit 6 – CINS Card Insertion Status Enable

Value	Name	Description
0	MASKED	The CINS status flag in NISTR is masked.
1	ENABLED	The CINS status flag in NISTR is enabled.

#### Bit 5 – BRDRDY Buffer Read Ready Status Enable

Value	Name	Description
0	MASKED	The BRDRDY status flag in NISTR is masked.
1	ENABLED	The BRDRDY status flag in NISTR is enabled.

#### Bit 4 – BWRRDY Buffer Write Ready Status Enable

Value	Name	Description
0	MASKED	The BWRRDY status flag in NISTR is masked.
1	ENABLED	The BWRRDY status flag in NISTR is enabled.

#### Bit 3 – DMAINT DMA Interrupt Status Enable

Value	Name	Description
0	MASKED	The DMAINT status flag in NISTR is masked.
1	ENABLED	The DMAINT status flag in NISTR is enabled.

**Bit 2 – BLKGE** Block Gap Event Status Enable

Value	Name	Description
0	MASKED	The BLKGE status flag in NISTR is masked.
1	ENABLED	The BLKGE status flag in NISTR is enabled.

**Bit 1 – TRFC** Transfer Complete Status Enable

Value	Name	Description
0	MASKED	The TRFC status flag in NISTR is masked.
1	ENABLED	The TRFC status flag in NISTR is enabled.

**Bit 0 – CMDC** Command Complete Status Enable

Value	Name	Description
0	MASKED	The CMDC status flag in NISTR is masked.
1	ENABLED	The CMDC status flag in NISTR is enabled.



### 36.7.20 Error Interrupt Status Enable Register

**Name:** EISTER  
**Offset:** 0x36  
**Reset:** 0x0000  
**Property:** -

Bit	15	14	13	12	11	10	9	8
				BOOTAE			ADMA	ACMD
Access				R/W			R/W	R/W
Reset				0			0	0
Bit	7	6	5	4	3	2	1	0
	CURLIM	DATEND	DATCRC	DATTEO	CMDIDX	CMDEND	CMDCRC	CMDTEO
Access	R/W	R/W	R/W	R/W	R/W	R/W	R/W	R/W
Reset	0	0	0	0	0	0	0	0

#### Bit 12 – BOOTAE Boot Acknowledge Error Status Enable

**Note:** This register entry is specific to the e.MMC operation mode.

Value	Name	Description
0	MASKED	The BOOTAE status flag in EISTR is masked.
1	ENABLED	The BOOTAE status flag in EISTR is enabled.

#### Bit 9 – ADMA ADMA Error Status Enable

Value	Name	Description
0	MASKED	The ADMA status flag in EISTR is masked.
1	ENABLED	The ADMA status flag in EISTR is enabled.

#### Bit 8 – ACMD Auto CMD Error Status Enable

Value	Name	Description
0	MASKED	The ACMD status flag in EISTR is masked.
1	ENABLED	The ACMD status flag in EISTR is enabled.

#### Bit 7 – CURLIM Current Limit Error Status Enable

Value	Name	Description
0	MASKED	The CURLIM status flag in EISTR is masked.
1	ENABLED	The CURLIM status flag in EISTR is enabled.

#### Bit 6 – DATEND Data End Bit Error Status Enable

Value	Name	Description
0	MASKED	The DATEND status flag in EISTR is masked.
1	ENABLED	The DATEND status flag in EISTR is enabled.

#### Bit 5 – DATCRC Data CRC Error Status Enable

Value	Name	Description
0	MASKED	The DATCRC status flag in EISTR is masked.
1	ENABLED	The DATCRC status flag in EISTR is enabled.

#### Bit 4 – DATTEO Data Timeout Error Status Enable

Value	Name	Description
0	MASKED	The DATTEO status flag in EISTR is masked.
1	ENABLED	The DATTEO status flag in EISTR is enabled.

#### Bit 3 – CMDIDX Command Index Error Status Enable

Value	Name	Description
0	MASKED	The CMDIDX status flag in EISTR is masked.
1	ENABLED	The CMDIDX status flag in EISTR is enabled.

**Bit 2 – CMDEND** Command End Bit Error Status Enable

Value	Name	Description
0	MASKED	The CMDEND status flag in EISTR is masked.
1	ENABLED	The CMDEND status flag in EISTR is enabled.

**Bit 1 – CMDCRC** Command CRC Error Status Enable

Value	Name	Description
0	MASKED	The CMDCRC status flag in EISTR is masked.
1	ENABLED	The CMDCRC status flag in EISTR is enabled.

**Bit 0 – CMDTEO** Command Timeout Error Status Enable

Value	Name	Description
0	MASKED	The CMDTEO status flag in EISTR is masked.
1	ENABLED	The CMDTEO status flag in EISTR is enabled.

### 36.7.21 Normal Interrupt Signal Enable Register

**Name:** NISIER  
**Offset:** 0x38  
**Reset:** 0x0000  
**Property:** -

Bit	15	14	13	12	11	10	9	8
		BOOTAR						CINT
Access		R/W						R/W
Reset		0						0
Bit	7	6	5	4	3	2	1	0
	CREM	CINS	BRDRDY	BWRRDY	DMAINT	BLKGE	TRFC	CMDC
Access	R/W	R/W	R/W	R/W	R/W	R/W	R/W	R/W
Reset	0	0	0	0	0	0	0	0

#### Bit 14 – BOOTAR Boot Acknowledge Received Signal Enable

**Note:** This register entry is specific to the e.MMC operation mode.

Value	Name	Description
0	MASKED	No interrupt is generated when NISTR.BOOTAR is set.
1	ENABLED	An interrupt is generated when NISTR.BOOTAR is set.

#### Bit 8 – CINT Card Interrupt Signal Enable

**Note:** This register entry is specific to the SD/SDIO operation mode.

Value	Name	Description
0	MASKED	No interrupt is generated when NISTR.CINT is set.
1	ENABLED	An interrupt is generated when NISTR.CINT is set.

#### Bit 7 – CREM Card Removal Signal Enable

**Note:** This register entry is specific to the SD/SDIO operation mode.

Value	Name	Description
0	MASKED	No interrupt is generated when NISTR.CREM is set.
1	ENABLED	An interrupt is generated when NISTR.CREM is set.

#### Bit 6 – CINS Card Insertion Signal Enable

**Note:** This register entry is specific to the SD/SDIO operation mode.

Value	Name	Description
0	MASKED	No interrupt is generated when NISTR.CINS is set.
1	ENABLED	An interrupt is generated when NISTR.CINS is set.

#### Bit 5 – BRDRDY Buffer Read Ready Signal Enable

Value	Name	Description
0	MASKED	No interrupt is generated when NISTR.BRDRDY is set.
1	ENABLED	An interrupt is generated when NISTR.BRDRDY is set.

#### Bit 4 – BWRRDY Buffer Write Ready Signal Enable

Value	Name	Description
0	MASKED	No interrupt is generated when NISTR.BWRRDY is set.
1	ENABLED	An interrupt is generated when NISTR.BWRRDY is set.

#### Bit 3 – DMAINT DMA Interrupt Signal Enable

Value	Name	Description
0	MASKED	No interrupt is generated when NISTR.DMAINT is set.
1	ENABLED	An interrupt is generated when NISTR.DMAINT is set.

**Bit 2 – BLKGE** Block Gap Event Signal Enable

Value	Name	Description
0	MASKED	No interrupt is generated when NISTR.BLKGE is set.
1	ENABLED	An interrupt is generated when NISTR.BLKGE is set.

**Bit 1 – TRFC** Transfer Complete Signal Enable

Value	Name	Description
0	MASKED	No interrupt is generated when NISTR.TRFC is set.
1	ENABLED	An interrupt is generated when NISTR.TRFC is set.

**Bit 0 – CMDC** Command Complete Signal Enable

Value	Name	Description
0	MASKED	No interrupt is generated when NISTR.CMDC is set.
1	ENABLED	An interrupt is generated when NISTR.CMDC is set.

### 36.7.22 Error Interrupt Signal Enable Register

**Name:** EISIER  
**Offset:** 0x3A  
**Reset:** 0x0000  
**Property:** -

Bit	15	14	13	12	11	10	9	8
				BOOTAE			ADMA	ACMD
Access				R/W			R/W	R/W
Reset				0			0	0
Bit	7	6	5	4	3	2	1	0
	CURLIM	DATEND	DATCRC	DATTEO	CMDIDX	CMDEND	CMDCRC	CMDTEO
Access	R/W	R/W	R/W	R/W	R/W	R/W	R/W	R/W
Reset	0	0	0	0	0	0	0	0

#### Bit 12 – BOOTAE Boot Acknowledge Error Signal Enable

**Note:** This register entry is specific to the e.MMC operation mode.

Value	Name	Description
0	MASKED	No interrupt is generated when EISTR.BOOTAE is set.
1	ENABLED	An interrupt is generated when EISTR.BOOTAE is set.

#### Bit 9 – ADMA ADMA Error Signal Enable

Value	Name	Description
0	MASKED	No interrupt is generated when EISTR.ADMA is set.
1	ENABLED	An interrupt is generated when EISTR.ADMA is set.

#### Bit 8 – ACMD Auto CMD Error Signal Enable

Value	Name	Description
0	MASKED	No interrupt is generated when EISTR.ACMD is set.
1	ENABLED	An interrupt is generated when EISTR.ACMD is set.

#### Bit 7 – CURLIM Current Limit Error Signal Enable

Value	Name	Description
0	MASKED	No interrupt is generated when EISTR.CURLIM is set.
1	ENABLED	An interrupt is generated when EISTR.CURLIM is set.

#### Bit 6 – DATEND Data End Bit Error Signal Enable

Value	Name	Description
0	MASKED	No interrupt is generated when EISTR.DATEND is set.
1	ENABLED	An interrupt is generated when EISTR.DATEND is set.

#### Bit 5 – DATCRC Data CRC Error Signal Enable

Value	Name	Description
0	MASKED	No interrupt is generated when EISTR.DATCRC is set.
1	ENABLED	An interrupt is generated when EISTR.DATCRC is set.

#### Bit 4 – DATTEO Data Timeout Error Signal Enable

Value	Name	Description
0	MASKED	No interrupt is generated when EISTR.DATTEO is set.
1	ENABLED	An interrupt is generated when EISTR.DATTEO is set.

#### Bit 3 – CMDIDX Command Index Error Signal Enable

Value	Name	Description
0	MASKED	No interrupt is generated when EISTR.CMDIDX is set.
1	ENABLED	An interrupt is generated when EISTR.CMDIDX is set.

**Bit 2 – CMDEND** Command End Bit Error Signal Enable

Value	Name	Description
0	MASKED	No interrupt is generated when EISTR.CMDEND is set.
1	ENABLED	An interrupt is generated when EISTR.CMDEND is set.

**Bit 1 – CMDCRC** Command CRC Error Signal Enable

Value	Name	Description
0	MASKED	No interrupt is generated when EISTR.CMDCRC is set.
1	ENABLED	An interrupt is generated when EISTR.CMDCRC is set.

**Bit 0 – CMDTEO** Command Timeout Error Signal Enable

Value	Name	Description
0	MASKED	No interrupt is generated when EISTR.CMDTEO is set.
1	ENABLED	An interrupt is generated when EISTR.CMDTEO is set.

### 36.7.23 Auto CMD Error Status Register

**Name:** ACESR  
**Offset:** 0x3C  
**Reset:** 0x0000  
**Property:** -

Bit	15	14	13	12	11	10	9	8
Access								
Reset								
Bit	7	6	5	4	3	2	1	0
Access	R			R	R	R	R	R
Reset	0			0	0	0	0	0

#### Bit 7 - CMDNI Command Not Issued by Auto CMD12 Error

Setting this bit to 1 means CMD\_wo\_DAT is not executed due to an Auto CMD12 error (ACESR[4:1]). This bit is set to 0 when Auto CMD Error is generated by Auto CMD23.

Value	Description
0	No error
1	Error

#### Bit 4 - ACMDIDX Auto CMD Index Error

This bit is set to 1 when the Command Index error occurs in response to a command.

Value	Description
0	No error
1	Error

#### Bit 3 - ACMDEND Auto CMD End Bit Error

This bit is set to 1 when detecting that the end bit of the command response is 0.

Value	Description
0	No error
1	Error

#### Bit 2 - ACMDCRC Auto CMD CRC Error

This bit is set to 1 when detecting a CRC error in the command response (refer to [Table 1-7](#) for more details).

#### Bit 1 - ACMDTEO Auto CMD Timeout Error

This bit is set to 1 if no response is returned within 64 SDCLK cycles from the end bit of the command. If this bit is set to 1, the other error status bits (ACESR[4:2]) are meaningless.

ACMDCRC	ACMDTEO	Types of error
0	0	No error
0	1	Response Timeout error
1	0	Response CRC error
1	1	CMD line conflict

#### Bit 0 - ACMD12NE Auto CMD12 Not Executed

If a memory multiple block data transfer is not started due to a command error, this bit is not set to 1 because it is not necessary to issue Auto CMD12. Setting this bit to 1 means the peripheral cannot

issue Auto CMD12 to stop a memory multiple block data transfer due to some error. If this bit is set to 1, other error status bits (ACESR[4:1]) are meaningless.

This bit is set to 0 when an Auto CMD error is generated by Auto CMD23.

Value	Description
0	No error
1	Error



### 36.7.24 Host Control 2 Register: e.MMC

**Name:** HC2R - EMMC  
**Offset:** 0x3E  
**Reset:** 0x0000  
**Property:** -

**Note:** The content of the HC2R register is depending on the mode. This description is for e.MMC mode. For SD/SDIO mode, see [36.7.25. HC2R - DEFAULT](#).

Bit	15	14	13	12	11	10	9	8
	PVALEN							
Access	R/W							
Reset	0							

Bit	7	6	5	4	3	2	1	0
	SCLKSEL	EXTUN	DRVSEL[1:0]		HS200EN[3:0]			
Access	R/W	R/W	R/W	R/W	R/W	R/W	R/W	R/W
Reset	0	0	0	0	0	0	0	0

#### Bit 15 – PVALEN Preset Value Enable

As the operating SDCLK frequency depends on the system implementation, it is difficult to determine these parameters in the standard host driver. When Preset Value Enable (PVALEN) is set to 1, automatic SDCLK frequency generation is performed without considering system-specific conditions. This bit enables the functions defined in PVR.

If this bit is written to 0, the Clock Generator Select bit (CCR.CLKGSEL) and the SDCLK Frequency Select bit (CCR.SDCLKFSEL) in the Clock Control Register (CCR) are selected by the user.

If this bit is set to 1, CCR.SDCLKFSEL and .CLKGSEL and HC2R.DRVSEL are set by the peripheral as specified in the Preset Value Register (PVR).

Value	Description
0	CCR.SDCLK, CCR.SDCLKFSEL controlled by the user.
1	Automatic selection by Preset Value is enabled.

#### Bit 7 – SCLKSEL Sampling Clock Select

The peripheral uses this bit to select the sampling clock to receive CMD and DAT.

This bit is set by the tuning procedure and is valid after completion of tuning (when EXTUN is cleared). Setting 1 means that tuning is completed successfully and setting 0 means that tuning has failed.

Writing 1 to this bit is meaningless and ignored. A tuning circuit is reset by writing to 0. This bit can be cleared by setting EXTUN to 1. Once the tuning circuit is reset, it takes time to complete a tuning sequence. Therefore, the user should keep this bit to 1 to perform a re-tuning sequence to complete a re-tuning sequence in a short time. Changing this bit is not allowed while the peripheral is receiving a response or a read data block. Refer to Figure 2.29 in the “SD Host Controller Simplified Specification V3.00” .

Value	Description
0	The fixed clock is used to sample data.
1	The tuned clock is used to sample data.

#### Bit 6 – EXTUN Execute Tuning

This bit is set to 1 to start the tuning procedure and is automatically cleared when the tuning procedure is completed. The result of tuning is indicated to Sampling Clock Select (SCLKSEL). The tuning procedure is aborted by writing 0. Refer to Figure 2.29 in the “SD Host Controller Simplified Specification V3.00” .

Value	Description
0	Not tuned or tuning completed

Value	Description
1	Execute tuning

**Bits 5:4 – DRVSEL[1:0]** Driver Strength Select

The peripheral output driver in 1.8V signaling is selected by this bit. In 3.3V signaling, this field is not effective. This field can be set according to the Driver Type A, C and D support bits in CA1R. This field depends on setting of Preset Value Enable (PVALEN):

- PVALEN=0 - This field is set by the user.
- PVALEN=1 - This field is automatically set by a value specified in one of the PVRx.

Value	Name	Description
0	TYPEB	Driver Type B is selected (Default)
1	TYPEA	Driver Type A is selected
2	TYPEC	Driver Type C is selected
3	TYPED	Driver Type D is selected

**Bits 3:0 – HS200EN[3:0]** HS200 Mode Enable

This field is used to select the e.MMC HS200 mode. When HS200EN is set to  $B_{(\text{hexa})}$ , the HS200 mode is enabled. Any other value except 0 is forbidden when interfacing an e.MMC device.

If Preset Value Enable is set to 1, peripheral sets SDCLK Frequency Select (SDCLKFSEL), Clock Generator Select (CLKGSEL) in CCR and Driver Strength Select (DRVSEL) according to PVR. In this case, one of the preset value registers is selected by this field. The user needs to reset SD Clock Enable (SDCLKEN) before changing this field to avoid generating a clock glitch. After setting this field, the user sets SDCLKEN to 1 again.

**Note:** This field is effective only if MC1R.DDR is written to 0.

### 36.7.25 Host Control 2 Register: SD/SDIO

**Name:** HC2R - DEFAULT  
**Offset:** 0x3E  
**Reset:** 0x0000  
**Property:** -

**Note:** The content of the HC2R register is depending on the mode. This description is for SD/SDIO mode. For e.MMC mode, see [36.7.24. HC2R - EMMC](#).

Bit	15	14	13	12	11	10	9	8
	PVALEN	ASINTEN						
Access	R/W	R/W						
Reset	0	0						
Bit	7	6	5	4	3	2	1	0
	SCLKSEL	EXTUN	DRVSEL[1:0]		VS18EN		UHSMS[2:0]	
Access	R/W	R/W	R/W	R/W	R/W	R/W	R/W	R/W
Reset	0	0	0	0	0	0	0	0

#### Bit 15 – PVALEN Preset Value Enable

As the operating SDCLK frequency depends on the system implementation, it is difficult to determine these parameters in the standard host driver. When Preset Value Enable (PVALEN) is set to 1, automatic SDCLK frequency generation is performed without considering system-specific conditions. This bit enables the functions defined in PVR.

If this bit is written to 0, the Clock Generator Select bit (CCR.CLKGSEL) and the SDCLK Frequency Select bit (CCR.SDCLKFSEL) in the Clock Control Register (CCR) are selected by the user.

If this bit is set to 1, CCR.SDCLKFSEL and .CLKGSEL and HC2R.DRVSEL are set by the peripheral as specified in the Preset Value Register (PVR).

Value	Description
0	CCR.SDCLK, CCR.SDCLKFSEL controlled by the user.
1	Automatic selection by Preset Value is enabled.

#### Bit 14 – ASINTEN Asynchronous Interrupt Enable

This bit can be set to 1 if a card support asynchronous interrupts and Asynchronous Interrupt Support (ASINTSUP) is set to 1 in CA0R. Asynchronous interrupt is effective when DAT[1] interrupt is used in 4-bit SD mode. If this bit is set to 1, the user can stop the SDCLK during the asynchronous interrupt period to save power. During this period, the peripheral continues to deliver the Card Interrupt to the host when it is asserted by the card.

Value	Description
0	Disabled
1	Enabled

#### Bit 7 – SCLKSEL Sampling Clock Select

The peripheral uses this bit to select the sampling clock to receive CMD and DAT.

This bit is set by the tuning procedure and is valid after completion of tuning (when EXTUN is cleared). Setting 1 means that tuning is completed successfully and setting 0 means that tuning has failed.

Writing 1 to this bit is meaningless and ignored. A tuning circuit is reset by writing to 0. This bit can be cleared by setting EXTUN to 1. Once the tuning circuit is reset, it takes time to complete the tuning sequence. Therefore, the user should keep this bit to 1 to perform a re-tuning sequence to complete a re-tuning sequence in a short time. Changing this bit is not allowed while the peripheral is receiving a response or a read data block. Refer to Figure 2.29 in the “SD Host Controller Simplified Specification V3.00” .

Value	Description
0	The fixed clock is used to sample data.
1	The tuned clock is used to sample data.

#### Bit 6 – EXTUN Execute Tuning

This bit is set to 1 to start the tuning procedure and is automatically cleared when the tuning procedure is completed. The result of tuning is indicated to Sampling Clock Select (SCLKSEL). The tuning procedure is aborted by writing 0. Refer to Figure 2.29 in the “SD Host Controller Simplified Specification V3.00” .

Value	Description
0	Not tuned or tuning completed
1	Execute tuning

#### Bits 5:4 – DRVSEL[1:0] Driver Strength Select

The peripheral output driver in 1.8V signaling is selected by this bit. In 3.3V signaling, this field is not effective. This field can be set according to the Driver Type A, C and D support bits in CA1R. This field depends on setting of Preset Value Enable (PVALEN):

- PVALEN=0 - This field is set by the user.
- PVALEN=1 - This field is automatically set by a value specified in one of the PVRx.

Value	Name	Description
0	TYPEB	Driver Type B is selected (Default)
1	TYPEA	Driver Type A is selected
2	TYPEC	Driver Type C is selected
3	TYPED	Driver Type D is selected

#### Bit 3 – VS18EN 1.8V Signaling Enable

This bit controls the voltage regulator for the I/O cell. 3.3V is supplied to the card regardless of the signaling voltage.

Setting this bit from 0 to 1 starts changing the signal voltage from 3.3V to 1.8V. The 1.8V regulator output must be stable within 5 ms.

Clearing this bit from 1 to 0 starts changing the signal voltage from 1.8V to 3.3V. The 3.3V regulator output must be stable within 5ms.

The user can set this bit to 1 when the peripheral supports 1.8V signaling (one of the support bits is set to 1: SDR50SUP, SDR104SUP or DDR50SUP in CA1R) and the card or device supports UHS-I (S18A = 1. Refer to “Bus Switch Voltage Switch Sequence in the “Physical Layer Simplified Specification V3.01”).

Value	Description
0	3.3V signaling
1	1.8V signaling

#### Bits 2:0 – UHSMS[2:0] UHS Mode Select

This field is used to select one of the UHS-I modes and is effective when 1.8V Signal Enable (VS18EN) is set to 1.

If Preset Value Enable is set to 1, the peripheral sets SDCLK Frequency Select (SDCLKFSEL), Clock Generator Select (CLKGSEL) in CCR and Driver Strength Select (DRVSEL) according to PVR. In this case, one of the preset value registers is selected by this field. The user needs to reset SD Clock Enable (SDCLKEN) before changing this field to avoid generating a clock glitch. After setting this field, the user sets SDCLKEN to 1 again.

Value	Name	Description
0	SDR12	UHS SDR12 Mode
1	SDR25	UHS SDR25 Mode
2	SDR50	UHS SDR50 Mode
3	SDR104	UHS SDR104 Mode

Value	Name	Description
4	DDR50	UHS DDR50 Mode Note: This field is effective only if MC1R.DDR is set to 0.

### 36.7.26 Capabilities 0 Register

**Name:** CAOR  
**Offset:** 0x40  
**Reset:** 0x27E80080  
**Property:** -

**Note:** The Capabilities 0 Register is not supposed to be written by the user.

Bit	31	30	29	28	27	26	25	24
	SLTYPE[1:0]		ASINTSUP	SB64SUP		V18VSUP	V30VSUP	V33VSUP
Access	R/W	R/W	R/W	R/W		R/W	R/W	R/W
Reset	0	0	1	0		1	1	1
Bit	23	22	21	20	19	18	17	16
	SRSUP	SDMASUP	HSSUP		ADMA2SUP	ED8SUP	MAXBLKL[1:0]	
Access	R/W	R/W	R/W		R/W	R/W	R/W	R/W
Reset	1	1	1		1	0	0	0
Bit	15	14	13	12	11	10	9	8
	BASECLKF[7:0]							
Access	R/W	R/W	R/W	R/W	R/W	R/W	R/W	R/W
Reset	0	0	0	0	0	0	0	0
Bit	7	6	5	4	3	2	1	0
	TEOCLKU		TEOCLKF[5:0]					
Access	R/W		R/W	R/W	R/W	R/W	R/W	R/W
Reset	1		0	0	0	0	0	0

#### Bits 31:30 – SLTYPE[1:0] Slot Type

This field indicates usage of a slot by a specific system. An peripheral control register set is defined per slot.

Embedded Slot for One Device means that only one non-removable device is connected to a bus slot.

The Standard Host Driver controls a removable card (SLTYPE = 0) or one embedded device (SLTYPE = 1) connected to an SD bus slot.

Value	Name	Description
0	REMOVABLE	Removable Card Slot
1	EMBEDDED	Embedded Slot for One Device
2	-	Reserved
3	-	Reserved

#### Bit 29 – ASINTSUP Asynchronous Interrupt Support

Refer to section “Asynchronous Interrupt” in the “SDIO Simplified Specification V3.00”.

Value	Description
0	Asynchronous interrupt not supported
1	Asynchronous interrupt supported

#### Bit 28 – SB64SUP 64-Bit System Bus Support

This bit indicates if the peripheral supports the 64-bit Address Descriptor mode and is connected to the 64-bit address system bus.

Value	Description
0	64-bit address bus not supported
1	64-bit address bus supported

**Bit 26 – V18VSUP** Voltage Support 1.8V

Value	Description
0	1.8V Voltage supply not supported
1	1.8V Voltage supply supported

**Bit 25 – V30VSUP** Voltage Support 3.0V

**Note:** The signal and supply voltages of the peripheral are limited by the supply voltage of the device.

Value	Description
0	3.0V Voltage supply not supported
1	3.0V Voltage supply supported

**Bit 24 – V33VSUP** Voltage Support 3.3V

**Note:** The signal and supply voltages of the peripheral are limited by the supply voltage of the device.

Value	Description
0	3.3V Voltage supply not supported
1	3.3V Voltage supply supported

**Bit 23 – SRSUP** Suspend/Resume Support

This bit indicates whether the peripheral supports the Suspend/Resume functionality. If this bit is set to 0, the user does not issue either Suspend or Resume commands because the Suspend and Resume mechanism (refer to “Suspend and Resume Mechanism” in the “SD Host Controller Simplified Specification V3.00” ) is not supported.

Value	Description
0	Suspend/Resume not supported
1	Suspend/Resume supported

**Bit 22 – SDMASUP** SDMA Support

This bit indicates whether the peripheral is capable of using SDMA to transfer data between system memory and the peripheral directly.

Value	Description
0	SDMA not supported
1	SDMA supported

**Bit 21 – HSSUP** High Speed Support

This bit indicates whether the peripheral and the system support High Speed mode and they can supply SDCLK frequency from 25MHz to 50MHz.

Value	Description
0	High Speed not supported
1	High Speed supported

**Bit 19 – ADMA2SUP** ADMA2 Support

This bit indicates whether the peripheral is capable of using ADMA2.

Value	Description
0	ADMA2 not supported
1	ADMA2 supported

**Bit 18 – ED8SUP** 8-Bit Support for Embedded Device

This bit indicates whether the peripheral is capable of using the 8-bit Bus Width mode.

Value	Description
0	8-bit bus width not supported
1	8-bit bus width supported

**Bits 17:16 – MAXBLKL[1:0]** Max Block Length

This field indicates the maximum block size that the user can read and write to the buffer in the peripheral.

**Note:** For SD Memory Cards, the transfer block length is always 512 bytes, regardless of this field.

Value	Name	Description
0	512	512 bytes
1–3	NONE	Reserved

**Bits 15:8 – BASECLKF[7:0]** Base Clock Frequency

This value indicates the frequency of the base clock (BASECLK). The user uses this value to calculate the clock divider value (refer to SDCLK Frequency Select (SDCLKFSEL) in CCR).

If this field is set to 0, the user must get the information via another method.

$$F_{\text{BASECLK}} = \text{BASECLKF}_{\text{MHz}}$$

**Bit 7 – TEOCLKU** Timeout Clock Unit

This bit shows the unit of the base clock frequency used to detect Data Timeout Error.

Value	Description
0	kHz
1	MHz

**Bits 5:0 – TEOCLKF[5:0]** Timeout Clock Frequency

This bit shows the timeout clock frequency (TEOCLK) used to detect Data Timeout Error.

If this field is set to 0, the user must get the information via another method.

The Timeout Clock Unit (TEOCLKU) defines the unit of this field's value.

– TEOCLKU = 0:

$$F_{\text{TEOCLK}} = \text{TEOCLKF}_{\text{kHz}}$$

– TEOCLKU = 1:

$$F_{\text{TEOCLK}} = \text{TEOCLKF}_{\text{MHz}}$$



### 36.7.27 Capabilities 1 Register

**Name:** CA1R  
**Offset:** 0x44  
**Reset:** 0x00000070  
**Property:** -

**Note:** The Capabilities 1 Register is not supposed to be written by the user.

Bit	31	30	29	28	27	26	25	24
Access								
Reset								
Bit	23	22	21	20	19	18	17	16
Access	CLKMULT[7:0]							
Reset	R/W	R/W	R/W	R/W	R/W	R/W	R/W	R/W
Reset	0	0	0	0	0	0	0	0
Bit	15	14	13	12	11	10	9	8
Access			TSDR50		TCNTRT[3:0]			
Reset			R/W		R/W	R/W	R/W	R/W
Reset			0		0	0	0	0
Bit	7	6	5	4	3	2	1	0
Access		DRVDSUP	DRVCSUP	DRVASUP		DDR50SUP	SDR104SUP	SDR50SUP
Reset		R/W	R/W	R/W		R/W	R/W	R/W
Reset		0	0	0		0	0	0

#### Bits 23:16 – CLKMULT[7:0] Clock Multiplier

This field indicates the multiplier factor between the Base Clock (BASECLK) used for the Divided Clock Mode and the Multiplied Clock (MULTCLK) used for the Programmable Clock mode (refer to CCR).

Reading this field to 0 means that the Programmable Clock mode is not supported.

$$F_{MULTCLK} = F_{BASECLK} \times (CLKMULT + 1)$$

#### Bit 13 – TSDR50 Use Tuning for SDR50

If this bit is set to 1, the peripheral requires tuning to operate SDR50 (tuning is always required to operate SDR104).

Value	Description
0	SDR50 does not require tuning.
1	SDR50 requires tuning.

#### Bits 11:8 – TCNTRT[3:0] Timer Count For Re-Tuning

This field indicates an initial value of the Re-Tuning Timer for Re-Tuning Mode (RTMODE) 1 to 3.

Reading this field at 0 means that the Re-Tuning Timer is disabled. The Re-Tuning Timer initial value ranges from 0 to 1024 seconds.

$$T_{TIMER} = 2^{(TCNTRT + 1)} \text{Seconds}$$

#### Bit 6 – DRVDSUP Driver Type D Support

Value	Description
0	Driver type D is not supported.

#### Bit 5 – DRVCSUP Driver Type C Support

Value	Description
0	Driver type C is not supported.

**Bit 4 – DRVASUP** Driver Type A Support

Value	Description
0	Driver type A is not supported.

**Bit 2 – DDR50SUP** DDR50 Support

Value	Description
0	DDR50 mode is not supported.

**Bit 1 – SDR104SUP** SDR104 Support

Value	Description
0	SDR104 mode is not supported.
1	SDR104 mode is supported.

**Bit 0 – SDR50SUP** SDR50 Support

Value	Description
0	SDR50 mode is not supported.
1	SDR50 mode is supported.

### 36.7.28 Maximum Current Capabilities Register

**Name:** MCCAR  
**Offset:** 0x48  
**Reset:** 0x00000000  
**Property:** -

Bit	31	30	29	28	27	26	25	24
Access								
Reset								
Bit	23	22	21	20	19	18	17	16
	MAXCUR18V[7:0]							
Access	R	R	R	R	R	R	R	R
Reset	0	0	0	0	0	0	0	0
Bit	15	14	13	12	11	10	9	8
	MAXCUR30V[7:0]							
Access	R	R	R	R	R	R	R	R
Reset	0	0	0	0	0	0	0	0
Bit	7	6	5	4	3	2	1	0
	MAXCUR33V[7:0]							
Access	R	R	R	R	R	R	R	R
Reset	0	0	0	0	0	0	0	0

#### Bits 23:16 – MAXCUR18V[7:0] Maximum Current for 1.8V

This field indicates the maximum current capability for 1.8V voltage. This value is meaningful only if V18VSUP is set to 1 in CA0RCA1R. Reading MAXCUR18V at 0 means that the user must get information via another method.

$$I_{max_{mA}} = 4 \times MAXCURR18V$$

#### Bits 15:8 – MAXCUR30V[7:0] Maximum Current for 3.0V

This field indicates the maximum current capability for 3.0V voltage. This value is meaningful only if V30VSUP is set to 1 in CA0R. Reading MAXCUR30V at 0 means that the user must get information via another method.

$$I_{max_{mA}} = 4 \times MAXCURR30V$$

#### Bits 7:0 – MAXCUR33V[7:0] Maximum Current for 3.3V

This field indicates the maximum current capability for 3.3V voltage. This value is meaningful only if V33VSUP is set to 1 in CA0R. Reading MAXCUR33V at 0 means that the user must get information via another method.

$$I_{max_{mA}} = 4 \times MAXCURR33V$$

### 36.7.29 Force Event Register for Auto CMD Error Status

**Name:** FERACES  
**Offset:** 0x50  
**Reset:** 0x0000  
**Property:** -

Bit	15	14	13	12	11	10	9	8
Access								
Reset								
Bit	7	6	5	4	3	2	1	0
Access	W			W	W	W	W	W
Reset	0			0	0	0	0	0

- Bit 7 - CMDNI** Force Event for Command Not Issued by Auto CMD12 Error  
For testing purposes, the user can write this bit to 1 to rise the CMDNI status flag in ACESR. Writing this bit to 0 has no effect.
- Bit 4 - ACMDIDX** Force Event for Auto CMD Index Error  
For testing purposes, the user can write this bit to 1 to rise the ACMDIDX status flag in ACESR. Writing this bit to 0 has no effect.
- Bit 3 - ACMDEND** Force Event for Auto CMD End Bit Error  
For testing purposes, the user can write this bit to 1 to rise the ACMDEND status flag in ACESR. Writing this bit to 0 has no effect.
- Bit 2 - ACMDCRC** Force Event for Auto CMD CRC Error  
For testing purposes, the user can write this bit to 1 to rise the ACMDCRC status flag in ACESR. Writing this bit to 0 has no effect.
- Bit 1 - ACMDTEO** Force Event for Auto CMD Timeout Error  
For testing purposes, the user can write this bit to 1 to rise the ACMDTEO status flag in ACESR. Writing this bit to 0 has no effect.
- Bit 0 - ACMD12NE** Force Event for Auto CMD12 Not Executed  
For testing purposes, the user can write this bit to 1 to rise the ACMD12NE status flag in ACESR. Writing this bit to 0 has no effect.

### 36.7.30 Force Event Register for Error Interrupt Status

**Name:** FEREIS  
**Offset:** 0x52  
**Reset:** 0x0000  
**Property:** -

Bit	15	14	13	12	11	10	9	8
				BOOTAE			ADMA	ACMD
Access				W			W	W
Reset				0			0	0

Bit	7	6	5	4	3	2	1	0
	CURLIM	DATEND	DATCRC	DATTEO	CMDIDX	CMDEND	CMDCRC	CMDTEO
Access	W	W	W	W	W	W	W	W
Reset	0	0	0	0	0	0	0	0

**Bit 12 - BOOTAE** Force Event for Boot Acknowledge Error  
For testing purposes, the user can write this bit to 1 to rise the BOOTAE status flag in EISTR.  
Writing this bit to 0 has no effect.

**Bit 9 - ADMA** Force Event for ADMA Error  
For testing purposes, the user can write this bit to 1 to rise the ADMA status flag in EISTR.  
Writing this bit to 0 has no effect.

**Bit 8 - ACMD** Force Event for Auto CMD Error  
For testing purposes, the user can write this bit to 1 to rise the ACMD status flag in EISTR.  
Writing this bit to 0 has no effect.

**Bit 7 - CURLIM** Force Event for Current Limit Error  
For testing purposes, the user can write this bit to 1 to rise the CURLIM status flag in EISTR.  
Writing this bit to 0 has no effect.

**Bit 6 - DATEND** Force Event for Data End Bit Error  
For testing purposes, the user can write this bit to 1 to rise the DATEND status flag in EISTR.  
Writing this bit to 0 has no effect.

**Bit 5 - DATCRC** Force Event for Data CRC error  
For testing purposes, the user can write this bit to 1 to rise the DATCRC status flag in EISTR.  
Writing this bit to 0 has no effect.

**Bit 4 - DATTEO** Force Event for Data Timeout error  
For testing purposes, the user can write this bit to 1 to rise the DATTEO status flag in EISTR.  
Writing this bit to 0 has no effect.

**Bit 3 - CMDIDX** Force Event for Command Index Error  
For testing purposes, the user can write this bit to 1 to rise the CMDIDX status flag in EISTR.  
Writing this bit to 0 has no effect.

**Bit 2 - CMDEND** Force Event for Command End Bit Error  
For testing purposes, the user can write this bit to 1 to rise the CDMEND status flag in EISTR.  
Writing this bit to 0 has no effect.

**Bit 1 – CMDCRC** Force Event for Command CRC Error

For testing purposes, the user can write this bit to 1 to rise the CMDCRC status flag in EISTR.  
Writing this bit to 0 has no effect.

**Bit 0 – CMDTEO** Force Event for Command Timeout Error

For testing purposes, the user can write this bit to 1 to rise the CMDTEO status flag in EISTR.  
Writing this bit to 0 has no effect.

### 36.7.31 ADMA Error Status Register

**Name:** AESR  
**Offset:** 0x54  
**Reset:** 0x00  
**Property:** -

Bit	7	6	5	4	3	2	1	0
						LMIS	ERRST[1:0]	
Access						R	R	R
Reset						0	0	0

#### Bit 2 – LMIS ADMA Length Mismatch Error

This error occurs in the following two cases:

- While Block Count Enable (BCEN) is being set, the total data length specified by the Descriptor table is different from that specified by the Block Count (BCNT) and Transfer Block Size (BLOCKSIZE).
- The total data length cannot be divided by the Transfer Block Size (BLOCKSIZE).

Value	Description
0	No error
1	Error

#### Bits 1:0 – ERRST[1:0] ADMA Error State

This field indicates the state of ADMA when an error has occurred during an ADMA data transfer. This field never indicates 2 because ADMA never stops in this state.

Value	Name	Description
0x0	STOP (Stop DMA)	Points to the descriptor following the error descriptor
0x1	FDS (Fetch Descriptor)	Points to the error descriptor
0x2	-	Reserved
0x3	TRF (Transfer Data)	Points to the descriptor following the error descriptor

### 36.7.32 ADMA System Address Register

**Name:** ASAR  
**Offset:** 0x58  
**Reset:** 0x00000000  
**Property:** -

Bit	31	30	29	28	27	26	25	24
	ADMASA[31:24]							
Access	R/W	R/W	R/W	R/W	R/W	R/W	R/W	R/W
Reset	0	0	0	0	0	0	0	0
Bit	23	22	21	20	19	18	17	16
	ADMASA[23:16]							
Access	R/W	R/W	R/W	R/W	R/W	R/W	R/W	R/W
Reset	0	0	0	0	0	0	0	0
Bit	15	14	13	12	11	10	9	8
	ADMASA[15:8]							
Access	R/W	R/W	R/W	R/W	R/W	R/W	R/W	R/W
Reset	0	0	0	0	0	0	0	0
Bit	7	6	5	4	3	2	1	0
	ADMASA[7:0]							
Access	R/W	R/W	R/W	R/W	R/W	R/W	R/W	R/W
Reset	0	0	0	0	0	0	0	0

#### Bits 31:0 – ADMASA[31:0] ADMA System Address

This field holds the byte address of the executing command of the descriptor table. At the start of ADMA, the user must set the start address of the descriptor table. The ADMA increments this register address, which points to the next Descriptor line to be fetched.

When the ADMA Error (ADMA) status flag rises, this field holds a valid descriptor address depending on the ADMA Error State (ERRST). The user must program Descriptor Table on 32-bit boundary and set 32-bit boundary address to this register. ADMA2 ignores the lower 2 bits of this register and assumes it to be 0.



### 36.7.33 Preset Value Register

**Name:** PVR  
**Offset:** 0x60 + n\*0x02 [n=0..7]  
**Reset:** 0x0000  
**Property:** Read/Write

One of the Preset Value Registers is effective based on the selected bus speed mode. The table below defines the conditions to select one of the PVRs.

**Table 36-3.** Preset Value Register Select Condition

Selected Bus Speed Mode	VS18EN (HC2R)	HSEN (HC1R)	UHSMS (HC2R)
Default Speed	0	0	don't care
High Speed	0	Response Timeout Error	don't care
Reserved	1	don't care	Other values

The following table shows the effective Preset Value Register according to the Selected Bus Speed mode.

**Table 36-4.** Preset Value Registers

PVRx	Selected Bus Speed Mode	Signal Voltage
PVR0	Initialization	3.3V or 1.8V
PVR1	Default Speed	3.3V
PVR2	High Speed	3.3V

When Preset Value Enable (PVALEN) in HC2R is set to 1, SDCLK Frequency Select (SDCLKFSEL) and Clock Generator Select (CLKGSEL) in CCR are automatically set based on the Selected Bus Speed mode. This means that the user does not need to set these fields when preset is enabled. A Preset Value Register for Initialization (PVR0) is not selected by Bus Speed mode. Before starting the initialization sequence, the user needs to set a clock preset value to SDCLKFSEL in CCR. PVALEN can be set to 1 after the initialization is completed.

**Note:** Preset Values in PVRx registers are not supposed to be written by the user. However, the user can modify preset values only if Capabilities Write Enable (CAPWREN) is written to 1 in CACR.

Bit	15	14	13	12	11	10	9	8
	DRVSEL[1:0]					CLKGSEL	SDCLKFSEL[9:8]	
Access	R/W	R/W				R/W	R/W	R/W
Reset	0	0				0	0	0
Bit	7	6	5	4	3	2	1	0
	SDCLKFSEL[7:0]							
Access	R/W	R/W	R/W	R/W	R/W	R/W	R/W	R/W
Reset	0	0	0	0	0	0	0	0

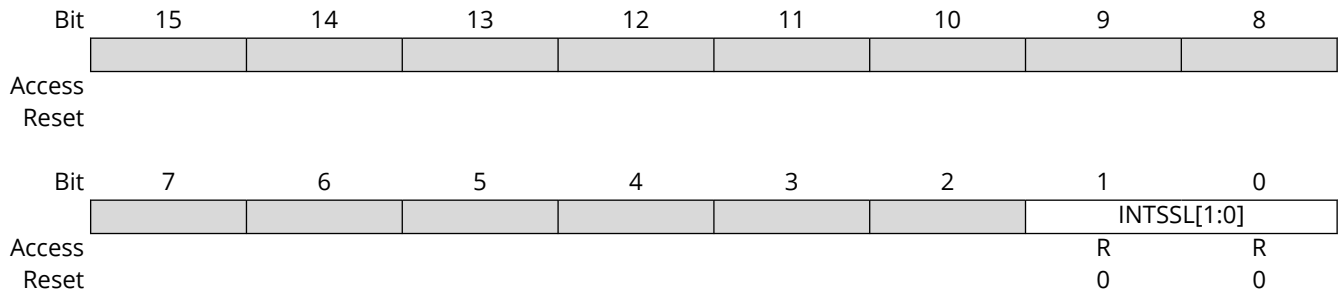
**Bits 15:14 – DRVSEL[1:0]** Driver Strength Select Value for Initialization  
Refer to DRVSEL in HC2R.

**Bit 10 – CLKGSEL** Clock Generator Select  
Refer to CGGSEL in CCR.

**Bits 9:0 – SDCLKFSEL[9:0]** SDCLK Frequency Select Value for Initialization  
Refer to SDCLKFSEL in CCR.

### 36.7.34 Slot Interrupt Status Register

**Name:** SISR  
**Offset:** 0xFC  
**Reset:** 0x0000  
**Property:** -



**Bits 1:0 – INTSSL[1:0]** Interrupt Signal for Each Slot

These status bits indicate the logical OR of Interrupt Signals and WakeUp Signal for each peripheral instance in the device. INTSSL[x] corresponds to instance SDHCx. There are 2 instances in this device.

### 36.7.35 Host Controller Version Register

**Name:** HCVR  
**Offset:** 0xFE  
**Reset:** 0x1802  
**Property:** -

Bit	15	14	13	12	11	10	9	8
	VVER[7:0]							
Access	R	R	R	R	R	R	R	R
Reset	0	0	0	1	1	0	0	0
Bit	7	6	5	4	3	2	1	0
	SVER[7:0]							
Access	R	R	R	R	R	R	R	R
Reset	0	0	0	0	0	0	1	0

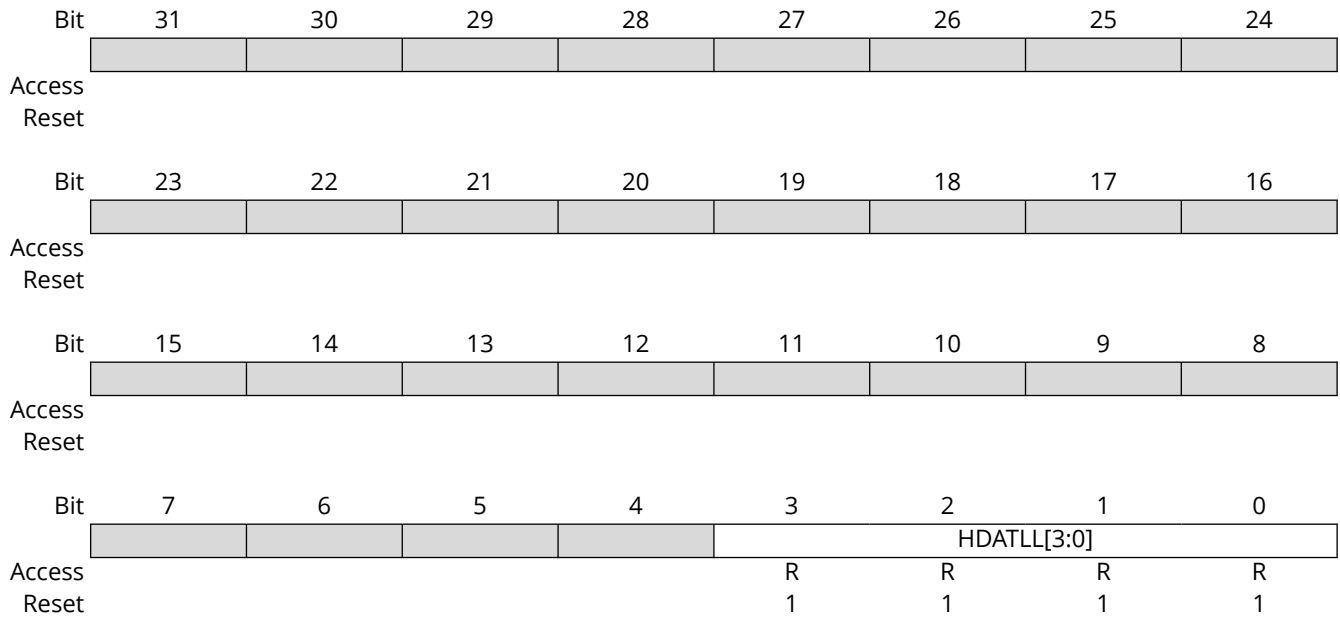
**Bits 15:8 – VVER[7:0]** Vendor Version Number  
 Reserved. Value subject to change. No functionality associated.

**Bits 7:0 – SVER[7:0]** Specification Version Number  
 This status indicates the SD Host Controller Specification Version.

Value	Name
0	Reserved
1	Reserved
2	SD Host Specification Version 3.00

### 36.7.36 Additional Present State Register

**Name:** APSR  
**Offset:** 0x200  
**Reset:** 0x0000000F  
**Property:** -



**Bits 3:0 – HDATLL[3:0]** High Line Level

This status is used to check the DAT[7:4] line level to recover from errors, and for debugging.

### 36.7.37 e.MMC Control 1 Register

**Name:** MC1R  
**Offset:** 0x204  
**Reset:** 0x00  
**Property:** R/W

Bit	7	6	5	4	3	2	1	0
	FCD	RSTN	BOOTA	OPD	DDR		CMDTYP[1:0]	
Access	R/W	R/W	R/W	R/W	R/W		R/W	R/W
Reset	0	0	0	0	0		0	0

#### Bit 7 – FCD e.MMC Force Card Detect

When using e.MMC, the user can set this bit to 1 to bypass the card detection procedure using the CD signal.

Value	Name	Description
0	DISABLED	e.MMC Forced Card Detect is disabled. The CD signal is used and debounce timing is applied.
1	ENABLED	e.MMC Forced Card Detect is enabled.

#### Bit 6 – RSTN e.MMC Reset Signal

This bit controls the e.MMC reset signal.

Value	Description
0	Reset signal is inactive.
1	Reset signal is active.

#### Bit 5 – BOOTA e.MMC Boot Acknowledge Enable

This bit must be set according to the value of BOOT\_ACK in the Extended CSD Register (refer to “Embedded MultiMedia Card (e.MMC) Electrical Standard 4.51”).

When this bit is set to 1, the peripheral waits for boot acknowledge pattern from the e.MMC before receiving boot data.

If the boot acknowledge pattern is wrong, the BOOTAE status flag rises in EISTR if BOOTAE is set in EISTER. An interrupt is generated if BOOTAE is set in EISIER.

If the no boot acknowledge pattern is received, the DATTEO status flag rises in EISTR if DATTEO is set in EISTER. An interrupt is generated if DATTEO is set in EISIER.

#### Bit 4 – OPD e.MMC Open Drain Mode

This bit sets the command line in open drain.

Value	Description
0	The command line is in push-pull.
1	The command line is in open drain.

#### Bit 3 – DDR e.MMC HSDDR Mode

This bit selects the High Speed DDR mode.

Value	Description
0	High Speed DDR is not selected.
1	High Speed DDR is selected.

Note: The clock divider (DIV) in CCR must be set to a value different from 0 when HSEN is 1.

#### Bits 1:0 – CMDTYP[1:0] e.MMC Command Type

Value	Name	Description
0	NORMAL	The command is not an e.MMC specific command.
1	WAITIRQ	This bit must be set to 1 when the e.MMC is in Interrupt mode (CMD40). Refer to “Interrupt Mode” in the “Embedded MultiMedia Card (e.MMC) Electrical Standard 4.51”.
2	STREAM	This bit must be set to 1 in the case of Stream Read (CMD11) or Stream Write (CMD20). Only effective for e.MMC up to revision 4.41.

Value	Name	Description
3	BOOT	Starts a Boot Operation mode at the next write to CR. Boot data are read directly from e.MMC device.

### 36.7.38 e.MMC Control 2 Register

**Name:** MC2R  
**Offset:** 0x205  
**Reset:** 0x00  
**Property:** -

Bit	7	6	5	4	3	2	1	0
							ABOOT	SRESP
Access							W	W
Reset							0	0

#### Bit 1 – ABOOT e.MMC Abort Boot

This bit is used to exit from Boot mode. Writing this bit to 1 exits the Boot Operation mode. Writing 0 is ignored.

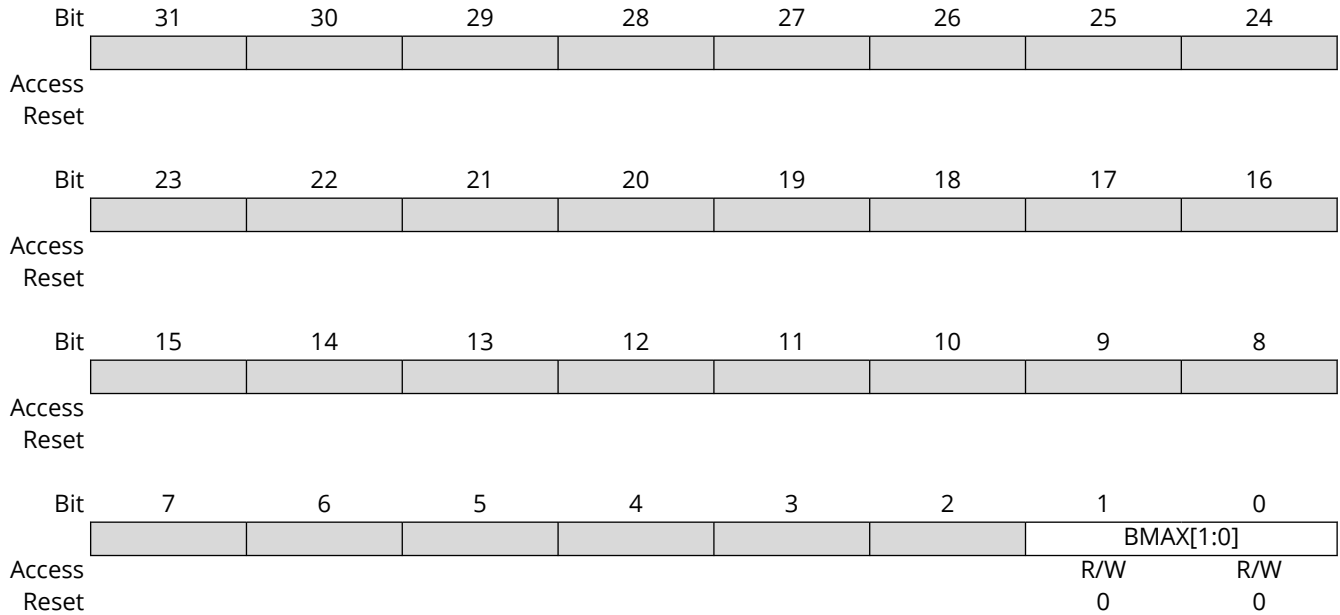
#### Bit 0 – SRESP e.MMC Abort Wait IRQ

This bit is used to exit from the Interrupt mode. When this bit is written to 1, the peripheral sends the CMD40 response automatically. This brings the e.MMC from Interrupt mode to the standard Data Transfer mode. Writing this bit to 0 is ignored.

Note: This bit is only effective when CMD\_TYP in MC1R is set to WAITIRQ.

### 36.7.39 AHB Control Register

**Name:** ACR  
**Offset:** 0x208  
**Reset:** 0x00000000  
**Property:** -



#### Bits 1:0 – BMAX[1:0] AHB Maximum Burst

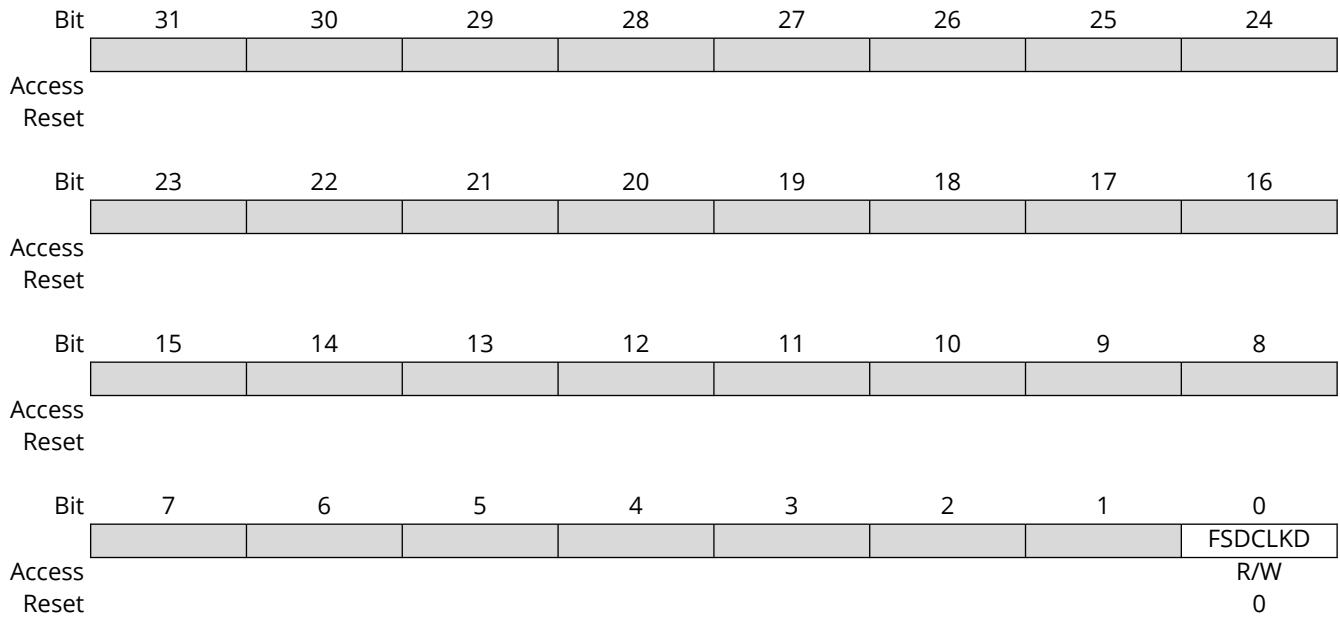
This field selects the maximum burst size in case of DMA transfer.

Value	Name	Description
0	INCR16	The maximum burst size is INCR16.
1	INCR8	The maximum burst size is INCR8.
2	INCR4	The maximum burst size is INCR4.
3	SINGLE	Only SINGLE transfers are performed.



### 36.7.40 Clock Control 2 Register

**Name:** CC2R  
**Offset:** 0x20C  
**Reset:** 0x00000000  
**Property:** -



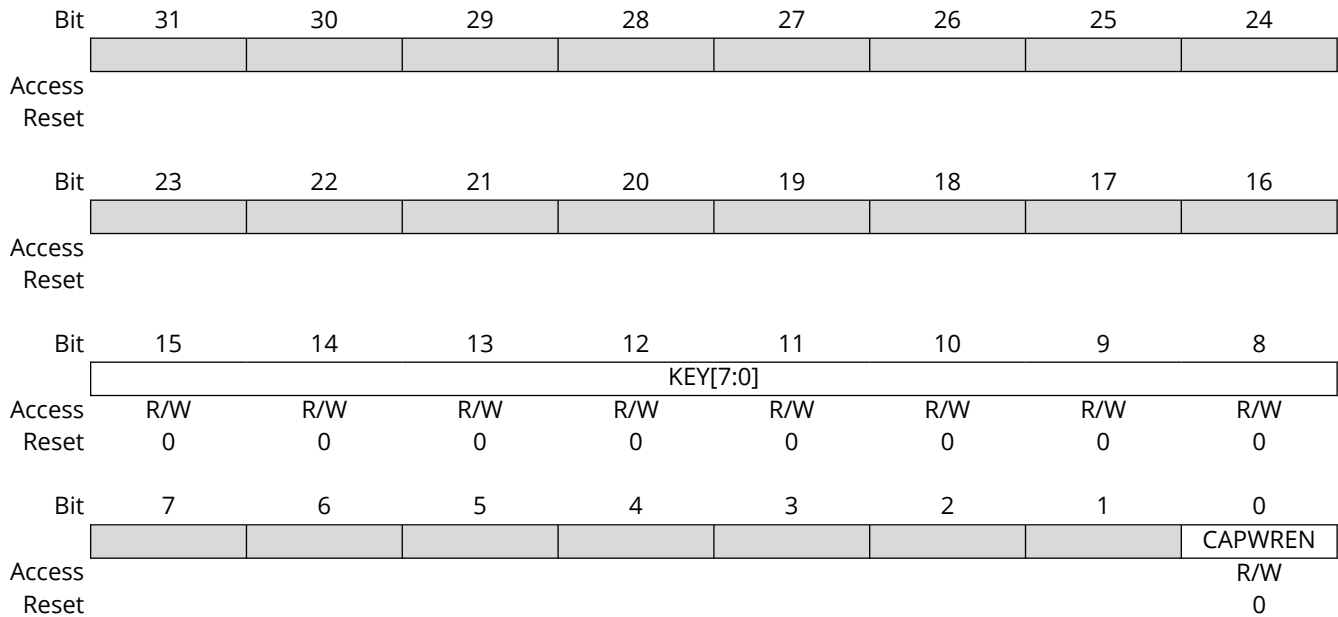
#### Bit 0 – FSDCLKD Force SDCLK Disabled

The user can choose to maintain the SDCLK during 8 SDCLK cycles after the end bit of the last data block in case of a read transaction, or after the end bit of the CRC status in case of a write transaction.

Value	Description
0	The SDCLK is forced and it cannot be stopped immediately after the transaction.
1	The SDCLK is not forced and it can be stopped immediately after the transaction.

### 36.7.41 Capabilities Control Register

**Name:** CACR  
**Offset:** 0x230  
**Reset:** 0x00000000  
**Property:** -



#### Bits 15:8 – KEY[7:0] Key

Value	Name	Description
0x46	KEY	Writing any other value in this field aborts the write operation of the CAPWREN bit. Always reads as 0.

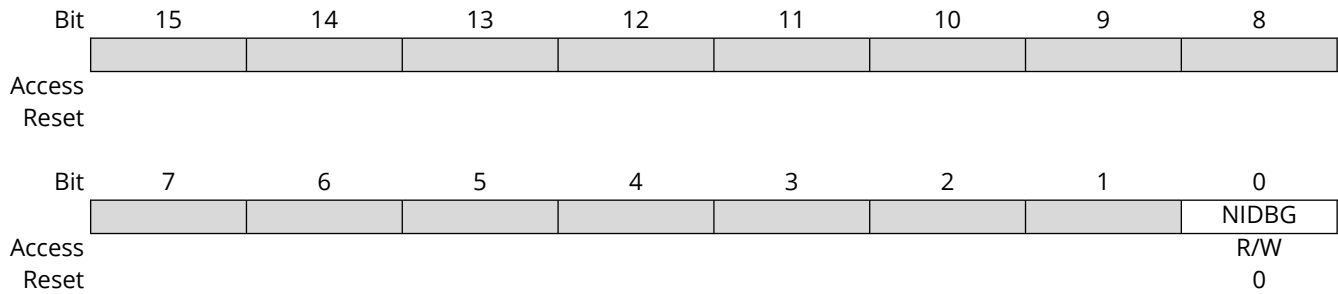
#### Bit 0 – CAPWREN Capabilities Write Enable

This bit can only be written if KEY correspond to 0x46.

Value	Description
0	Capabilities registers (CA0R and CA1R) cannot be written.
1	Capabilities registers (CA0R and CA1R) can be written.

### 36.7.42 Debug Register

**Name:** DBGR  
**Offset:** 0x234  
**Reset:** 0x00  
**Property:** -



#### Bit 0 - NIDBG Non-Intrusive Debug

Value	Name	Description
0	IDBG	Reading the BDPR via debugger increments the dual port RAM read pointer.
1	NIDBG	Reading the BDPR via debugger does not increment the dual port RAM read pointer.

## 37. Inter-IC Sound Controller (I<sup>2</sup>S)

### 37.1 Overview

The Inter-IC Sound Controller (I<sup>2</sup>S) provides bidirectional, synchronous and digital audio link with external audio devices.

This controller is compliant with the Inter-IC Sound (I<sup>2</sup>S) bus specification. It supports TDM interface with external multi-slot audio codecs. It also supports PDM interface with external MEMS microphones.

The I<sup>2</sup>S consists of two Clock Units, Transmit Serializer and Receive Serializer, that can be enabled separately to provide Host, Client, or controller modes.

The pins associated with I<sup>2</sup>S peripheral are SDO, SDI, FS<sub>n</sub>, SCK<sub>n</sub>, and MCK<sub>n</sub> pins.

Peripheral DMAC channels, separate for each Serializer, allow a continuous high bitrate data transfer without processor intervention to the following:

- Audio codecs in Host, Client, or Controller mode
- Stereo DAC or ADC through dedicated I<sup>2</sup>S serial interface
- Multi-slot or multiple stereo DACs or ADCs, using the TDM format
- Mono or stereo MEMS microphones, using the PDM interface

Each Serializer supports using either a single DMAC channel for all data channels, or two separate DMAC channels for different data channels.

The I<sup>2</sup>S supports 8-bit and 16-bit compact stereo format. This helps in reducing the required DMA bandwidth by transferring the left and right samples within the same data word.

Usually, an external audio codec or digital signal processor (DSP) requires a clock which is a multiple of the sampling frequency  $f_s$  (for example,  $384 \times f_s$ ). The I<sup>2</sup>S peripheral in Host Mode and Controller mode is capable of outputting an output clock ranging from  $16 \times f_s$  to  $1024 \times f_s$  on the Host Clock pin (MCK<sub>n</sub>). The Host Clock pin cannot output a clock signal when in Client Mode.

### 37.2 Features

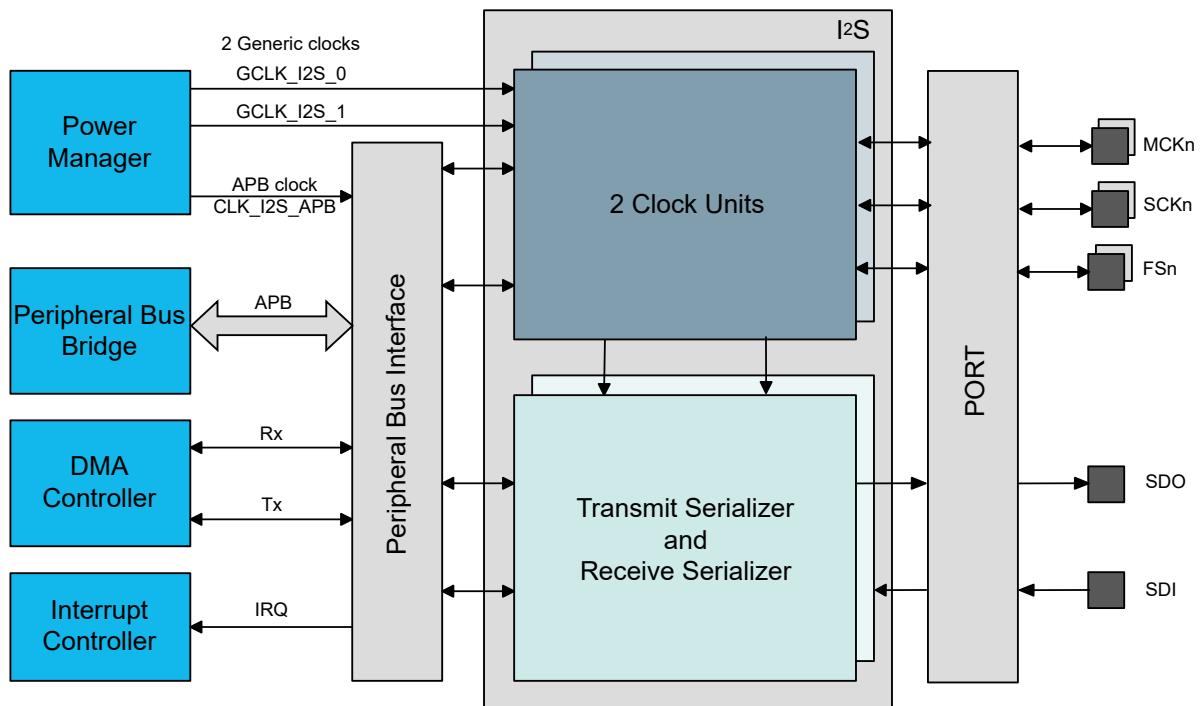
The following are key features of the I<sup>2</sup>S module:

- Compliant with Inter-IC Sound (I<sup>2</sup>S) bus specification
- Supported data formats:
  - 32-bit, 24-bit, 20-bit, 18-bit, 16-bit, and 8-bit mono or stereo format
  - 16-bit and 8-bit compact stereo format, with left and right samples packed in the same word to reduce data transfers
- Supported data frame formats:
  - 2-channel I<sup>2</sup>S with Word Select
  - 1- to 8-slot Time Division Multiplexed (TDM) with Frame Sync and individually enabled slots
  - 1- or 2-channel Pulse Density Modulation (PDM) reception for MEMS microphones
  - 1-channel burst transfer with non-periodic Frame Sync
- 2 independent Clock Units handling either the same clock or separate clocks for the Serializers:
  - Suitable for a wide range of sample frequencies  $f_s$ , including 32 kHz, 44.1 kHz, 48 kHz, 88.2 kHz, 96 kHz, and 192 kHz
  - $16 \times f_s$  to  $1024 \times f_s$  Host Clock generated for external audio CODECs
- Host, Client, and controller modes:

- Host: Data received or transmitted based on internally-generated clocks. Output Serial Clock on the SCKn pin, Host Clock on the MCKn pin, and Frame Sync Clock on the FSn pin
- Client: Data received or transmitted based on external clocks on Serial Clock pin (SCKn) or Host Clock pin (MCKn)
- Controller: Only output internally generated Host clock (MCKn), Serial Clock (SCKn), and Frame Sync Clock (FSn)
- Individual enabling and disabling of Clock Units and Serializers
- DMA interfaces for each Serializer receiver or transmitter to reduce processor overhead:
  - Either one DMA channel for all data slots
  - One DMA channel per data channel in stereo
- Smart Data Holding register management to avoid data slots mix after overrun or underrun

### 37.3 Block Diagram

Figure 37-1. I<sup>2</sup>S Block Diagram



### 37.4 Signal Description

Table 37-1.

Pin Name	Pin Description	Type
MCKn	Host Clock for Clock Unit n	Input/Output
SCKn	Serial Clock for Clock Unit n	Input/Output
FSn	I <sup>2</sup> S Word Select or TDM Frame Sync for Clock Unit n	Input/Output
SDO	Serial Data Output for Transmit Serializer	Output
SDI	Serial Data Input for Receive Serializer	Input



I/Os for I<sup>2</sup>S peripheral are grouped into I/O sets, listed in their 'IOSET' column in the pinout tables.

For these peripherals, it is mandatory to use I/Os that belong to the same I/O set. The timings are not guaranteed when I/Os from different I/O sets are mixed. Refer to the [Pinout and Packaging](#) chapter to get IOSET definitions.

## 37.5 Peripheral Dependencies

<b>Peripheral Name</b>	I <sup>2</sup> S - Inter-IC Sound Controller
<b>Base Address</b>	0x4300_2800 (Peripheral Bus D)
<b>NVIC IRQ Index:Source</b>	128 : RXOR0, RXOR1, RXRDY0, RXRDY1, TXRDY0, TXRDY1, TXUR0, TXUR1
<b>MCLK APB Clock (1)</b>	CLK_I2S_AHB, Disabled, APBDMASK.I2S
<b>GCLK Peripheral Channel Index:Clock Name (2)</b>	43:44 GCLK_I2S_0, GCLK_I2S_1
<b>PAC Peripheral Identifier (PAC.WRCTRL)</b>	106
<b>DMA Trigger Index:Source (DMAC.CHCTRLAK,k=0,1,...31)</b>	76,77 : RX triggers; 78,79 : TX Triggers
<b>Notes:</b>	
1.	Clock Name, Default State, Mask Field.
2.	See GCLK.PCHCTRLm Register, where m = Index.

### 37.5.1 Power Management

The I<sup>2</sup>S will continue to operate in any sleep mode where the selected source clocks are running.

### 37.5.2 Clocks

The clock for the I<sup>2</sup>S bus interface (CLK\_I2S\_APB) is generated by the [Power Manager](#). This clock is disabled at reset, and can be enabled in the Power Manager. It is recommended to disable the I<sup>2</sup>S before disabling the clock, to avoid freezing the I<sup>2</sup>S in an undefined state.

There are two generic clocks, GCLK\_I2S\_0 and GCLK\_I2S\_1, connected to the I<sup>2</sup>S peripheral, one for each I<sup>2</sup>S clock unit. The generic clocks (GCLK\_I2S\_n, n=0..1) can be set to a wide range of frequencies and clock sources. The GCLK\_I2S\_n must be enabled and configured before use.

The GCLK\_I2S\_n clocks must be enabled and configured before triggering Software Reset, so that the logic in all clock domains can be reset.

The generic clocks are only used in Host mode and Controller mode. In Host mode, the clock from clock unit 0 can be used for both Serializers to handle synchronous transfers, or a separate clock from different clock units can be used for each Serializer to handle transfers on non-related clocks.

### 37.5.3 Debug Operation

When the CPU is halted in Debug mode, this peripheral will continue normal operation. If the peripheral is configured to require periodical service by the CPU through interrupts or similar, improper operation or data loss may result during debugging. This peripheral can be forced to halt operation during debugging.

### 37.5.4 Register Access Protection

Registers with write access can be optionally write-protected by the [Peripheral Access Controller \(PAC\)](#), except for the following:

- DATAm
- INTFLAG
- SYNCBUSY

**Note:** Optional write protection is indicated by the "PAC Write Protection" property in the register description.

Write protection does not apply for accesses through an external debugger.

## 37.6 Functional Description

### 37.6.1 Principle of Operation

The I<sup>2</sup>S uses three or four communication lines for synchronous data transfer:

- SDO output for Transmit Serializer
- SDI input for Receive Serializer
- SCKn for the serial clock in Clock Unit n (n = 0..1)
- FSn for the frame synchronization or I<sup>2</sup>S word select, identifying the beginning of each frame
- Optionally, MCKn to output an oversampling clock to an external codec

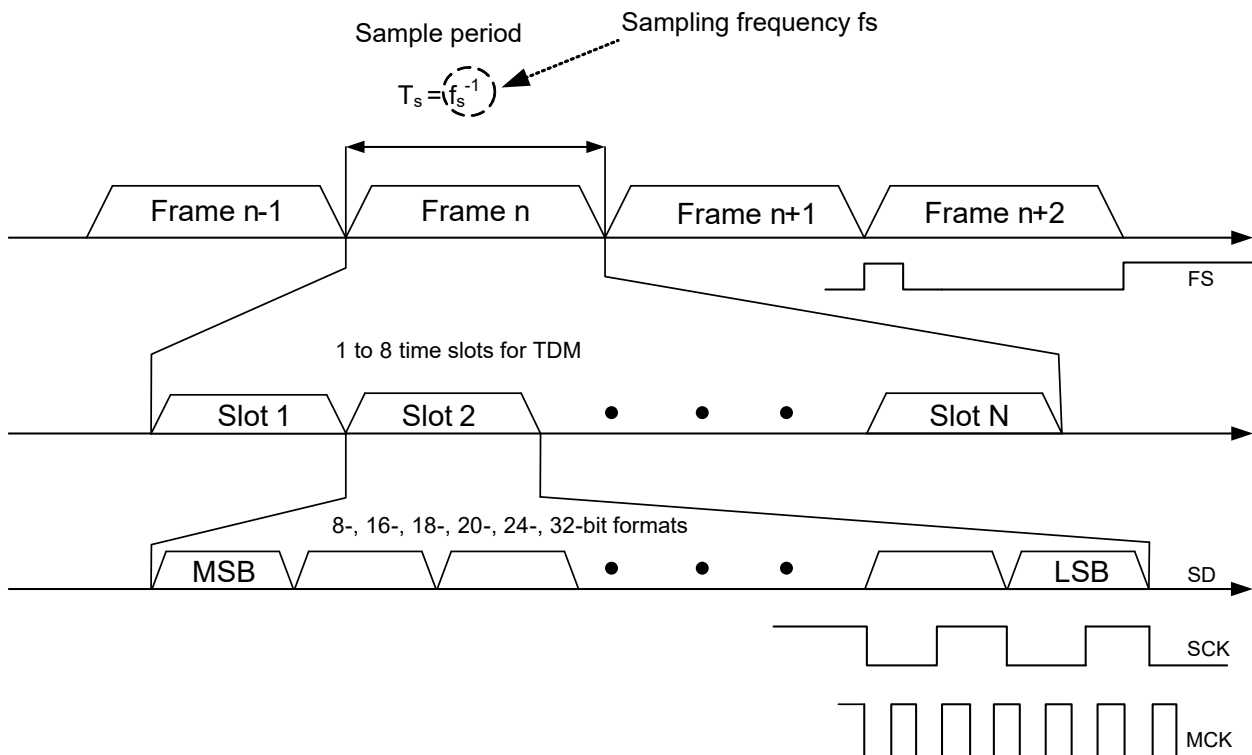
I<sup>2</sup>S data transfer is frame based, where a serial frame:

- Starts with the frame synchronization active edge, and
- Consists of 1 to 8 data slots, that are 8-bit, 16-bit, 24-bit, or 32-bit wide.

Each data slot is used to transfer one data sample of 8-bit, 16-bit, 18-bit, 20-bit, 24-bit or 32-bit.

Frame based data transfer is described in the following figure:

**Figure 37-2.** Data Format: Frames, Slot, Bits and Clocks



I<sup>2</sup>S supports multiple data formats such as:

- 32-bit, 24-bit, 20-bit, 18-bit, 16-bit, and 8-bit mono or stereo format
- 16-bit and 8-bit compact stereo format, with left and right samples packed in the same word to reduce data transfers

In mono format, Transmit mode, data written to the left channel is duplicated to the right output channel. In mono format, Receiver mode, data received from the right channel is ignored and data received from the left channel is duplicated in to the right channel.

In mono format, TDM Transmit mode with more than two slots, data written to the even-numbered slots is duplicated in to the following odd-numbered slot.

In mono format, TDM Receiver mode with more than two slots, data received from the even-numbered slots is duplicated in to the following odd-numbered slot.

Mono format can be enabled by writing a '1' to the MONO bit in the Serializer m Control register (SERCTRLm.MONO).

I<sup>2</sup>S support different data frame formats:

- 2-channel I<sup>2</sup>S with Word Select
- 1- to 8-slot Time Division Multiplexed (TDM) with Frame Sync and individually enabled slots
- 1- or 2-channel Pulse Density Modulation (PDM) reception for MEMS microphones
- 1-channel burst transfer with non-periodic Frame Sync

In 2 channel I<sup>2</sup>S mode, number of slots configured is one or two and successive data words corresponds to left and right channel. Left and right channel are identified by polarity of Word Select signal (FSn signal). Each frame consists of one or two data word(s). In the case of compact stereo format, the number of slots can be one. When 32-bit slot size is used, the number of slots can be two.

In TDM format, number slots can be configured up to 8 slots. If 4 slots are configured, each frame consists of 4 data words.

In PDM format, continuous 1-bit data samples are available on the SDI line for each SCKn rising and SCKn falling edge as in case of a MEMS microphone with PDM interface.

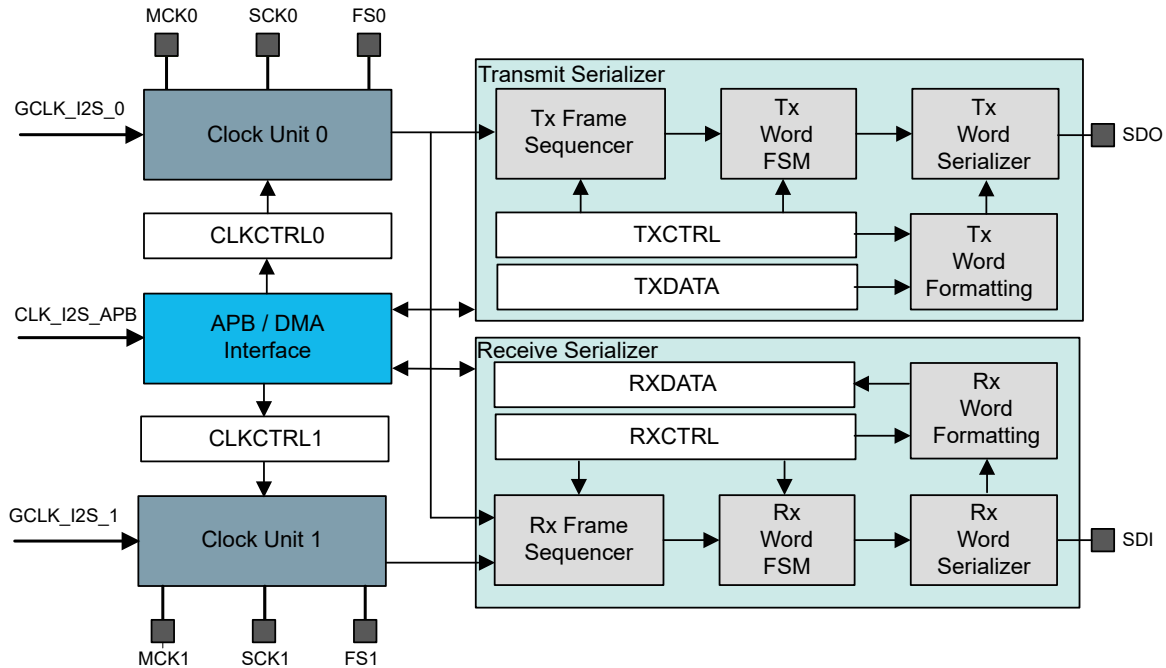
1-channel burst transfer with non-periodic Frame Sync mode is useful typically for passing control non-auto data as in case of DSP. In Burst mode, a single Data transfer starts at each Frame Sync pulse, and these pulses are 1-bit wide and occur only when a Data transfer is requested.

**Note:** Compact stereo modes (16C and 8C) are not supported in the Burst mode.

Sections [37.6.4. I2S Format - Reception and Transmission Sequence with Word Select](#), [37.6.5. TDM Format - Reception and Transmission Sequence](#) and [37.7. I2S Application Examples](#) describe more about frame/data formats and register settings required for different I<sup>2</sup>S applications.



Figure 37-3. I<sup>2</sup>S Functional Block Diagram



### 37.6.1.1 Initialization

The I<sup>2</sup>S features two Clock Units, one Transmit Serializer, and One Receive Serializer. The Transmit Serializer uses Clock Unit 0, while the Receive Serializer can either share the same Clock Unit 0 or use the Clock Unit 1.

Before enabling the I<sup>2</sup>S, the following registers must be configured:

- Clock Control registers (CLKCTRLn)
- Serializer Control registers (TXCTRL and/or RXCTRL)

In Host mode, one of the generic clocks for the I<sup>2</sup>S must also be configured to operate at the required frequency, as described in [37.6.1. Principle of Operation](#).

- $f_s$  is the sampling frequency that defines the frame period
- CLKCTRLn.NBSLOTS defines the number of slots in each frame
- CLKCTRLn.SLOTSIZE defines the number of bits in each slot
- SCKn frequency must be  $f_{SCKn} = f_s \times \text{number\_of\_slots} \times \text{number\_of\_bits\_per\_slot}$

Once the configuration has been written, the I<sup>2</sup>S Clock Units and Serializers can be enabled by writing a '1' to the CKENn, TXEN, and/or RXEN bits and to the ENABLE bit in the Control register (CTRLA). The Clock Unit n can be enabled alone, in Controller Mode, to output clocks to the MCKn, SCKn, and FSn pins. The Clock Units must be enabled if Serializers are enabled.

The Clock Units, the Transmit Serializer and the Receive Serializer can be disabled independently by writing a '0' to CTRLA.CKENn, CTRLA.TXEN, and CTRLA.RXEN, respectively. Once requested to stop, they will only stop when the pending transmit frames will be completed, if any. When requested to stop, the ongoing reception of the current slot will be completed and then the Serializer will be stopped.

**Example 37-1.** *Example Requirements:*  $f_s=48\text{kHz}$ ,  $\text{MCKn}=384 \times f_s$

If a  $384 \times f_s$  MCKn Host Clock is required (i.e. 18.432MHz), the I<sup>2</sup>S generic clock could run at 18.432MHz with a Host Clock Output Division Factor of 1 (selected by writing  $\text{CLKCTRLn.MCKOUTDIV}=0x0$ ) in order to obtain the desired MCKn frequency.

When using 6 slots per frame ( $\text{CLKCTRLn.NBSLOTS}=0x5$ ) and 32-bit slots ( $\text{CLKCTRLn.SLOTSIZE}=0x3$ ), the desired SCKn frequency is

$$f_{\text{SCKn}} = 48\text{kHz} \times 6 \times 32 = 9.216\text{MHz}$$

This frequency can be achieved by dividing the I<sup>2</sup>S generic clock output of 18.432MHz by factor 2: Writing  $\text{CLKCTRLn.MCKDIV}=0x1$  will select the correct division factor and output the desired SCKn frequency of 9.216MHz to the SCKn pin.

If MCKn is not required, the generic clock could be set to 9.216MHz and  $\text{CLKCTRLn.MCKDIV}=0x0$ .

### 37.6.2 Basic Operation

The Receiver can be operated by reading the Receive Data Holding register (RXDATA), whenever the Receive Ready m bit in the Interrupt Flag Status and Clear register (INTFLAG.RXRDYm) is set. Successive values read from the RXDATA register will correspond to the samples from the left and right audio channels. In TDM mode, the successive values read from RXDATA correspond to the first slot to the last slot. For instance, if I<sup>2</sup>S is configured in TDM mode with 4 slots in a frame, then successive values written to RXDATA register correspond to first, second, third, and fourth slot. The number of slots in TDM is configured in  $\text{CLKCTRLn.NBSLOTS}$ .

The Transmitter can be operated by writing to the Transmit Data Holding register (TXDATA), whenever the Transmit Ready m bit in the Interrupt Flag Status and Clear register (INTFLAG.TXRDYm) is set. Successive values written to TXDATA register should correspond to the samples from the left and right audio channels. In TDM mode, the successive values written to TXDATA correspond to the first, second, third, slot to the last slot. The number of slots in TDM is configured in  $\text{CLKCTRLn.NBSLOTS}$ .

The Receive Ready and Transmit Ready bits can be polled by reading the INTFLAG register.

The processor load can be reduced by enabling interrupt-driven operation. The RXRDYm and/or TXRDYm interrupt requests can be enabled by writing a '1' to the corresponding bit in the Interrupt Enable register (INTENSET). The interrupt service routine associated to the I<sup>2</sup>S interrupt request will then be executed whenever Receive Ready or Transmit Ready status bits are set.

The processor load can be reduced further by enabling DMA-driven operation. Then, the DMA channels support up to four trigger sources from the I<sup>2</sup>S peripheral. These four trigger sources in DMAC channel are

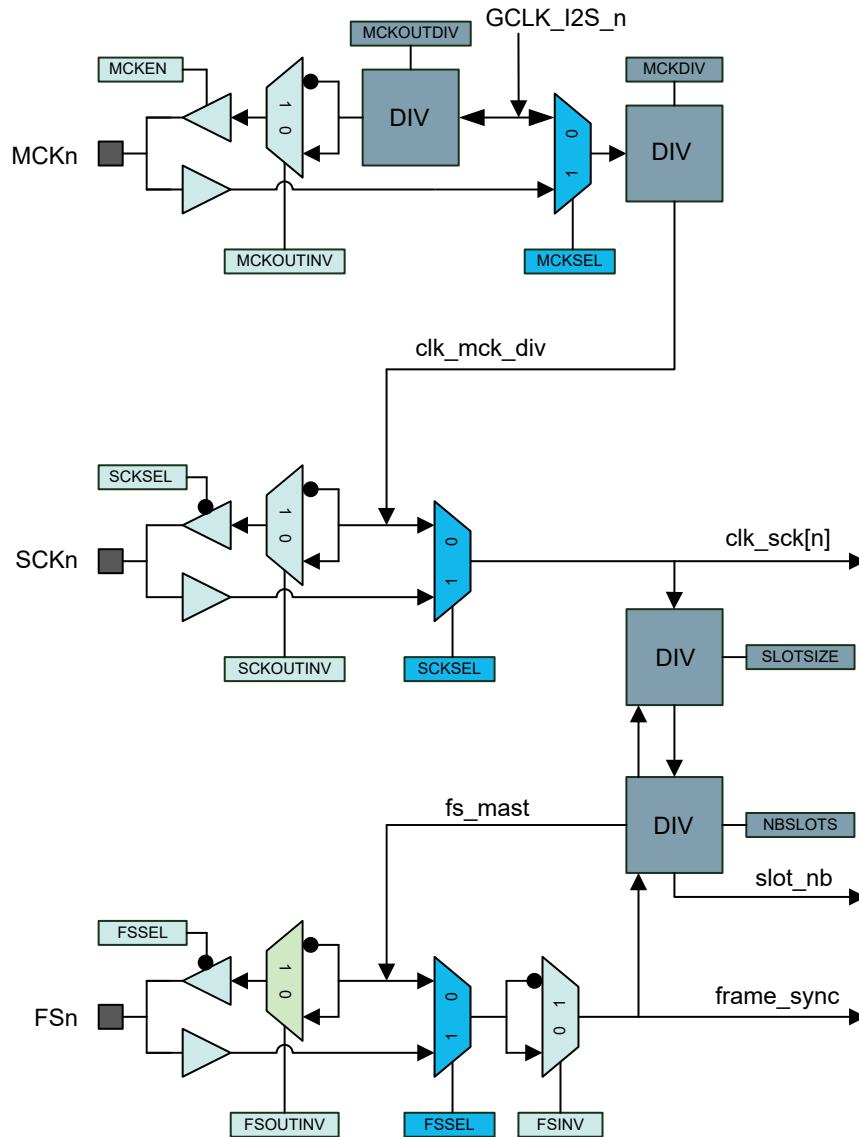
- I2S RX 0,
- I2S RX 1,
- I2S TX 0, and
- I2S TX 1.

For further reference, these are called I2S\_DMACH\_ID\_RX\_m and I2S\_DMACH\_ID\_TX\_m triggers (m=0..1). By using these trigger sources, one DMA data transfer will be executed whenever the Receive Ready or Transmit Ready status bits are set.

#### 37.6.2.1 Host Clock, Serial Clock, and Frame Sync Generation

The generation of clocks in the I<sup>2</sup>S is described in the next figure.

Figure 37-4. I<sup>2</sup>S Clocks



Generation

### 37.6.2.1.1 Client Mode

In Client mode, the Serial Clock and Frame Sync (Word Select in I<sup>2</sup>S mode and Frame Sync in TDM mode) are driven by an external Host. SCKn and FSn pins are inputs and no generic clock is required by the I<sup>2</sup>S.

### 37.6.2.1.2 Host Mode and Controller Mode

In Host Mode, the Host Clock (MCKn), the Serial Clock (SCKn), and the Frame Sync Clock (FSn) are generated by the I<sup>2</sup>S controller. The user can configure the Host Clock, Serial Clock, and Word Select Frame Sync signal (Word Select in I<sup>2</sup>S mode and Frame Sync in TDM mode) using the Clock Unit n Control register (CLKCTRLn). MCKn, SCKn, and FSn pins are outputs and a generic clock is used to derive the I<sup>2</sup>S clocks.

In some applications, audio CODECs connected to the I<sup>2</sup>S pins may require a Host Clock signal with a frequency multiple of the audio sample frequency *fs*, such as 256×*fs*.

In Controller mode, only the Clock generation unit needs to be configured by writing to the CTRLA and CLKCTRLn registers, where parameters such as clock division factors, Number of slots, Slot size, Frame Sync signal, clock enable are selected.

### 37.6.2.1.3 MCKn Clock Frequency

When the I<sup>2</sup>S is in Host mode, writing a '1' to CLKCTRLn.MCKEN will output GCLK\_I2S\_n as Host Clock to the MCKn pin. The Host Clock to MCKn pin can be divided by writing to CLKCTRLn.MCKSEL and CLKCTRLn.MCKOUTDIV. The Host Clock (MCKn) frequency is GCLK\_I2S\_n frequency divided by (MCKOUTDIV+1).

$$f(\text{MCKn}) = \frac{f(\text{GCLK\_I2S\_n})}{(\text{MCKOUTDIV}+1)}$$

### 37.6.2.1.4 SCKn Clock Frequency

When the Serial Clock (SCKn) is generated from GCLK\_I2S\_n and both CLKCTRLn.MCKSEL and CLKCTRLn.SCKSEL are zero, the Serial Clock (SCKn) frequency is GCLK\_I2S\_n frequency divided by (MCKDIV+1).

i.e.

$$f(\text{SCKn}) = \frac{f(\text{GCLK\_I2S\_n})}{(\text{MCKDIV}+1)}$$

### 37.6.2.1.5 Relation Between MCKn, SCKn, and Sampling Frequency fs

Based on sampling frequency  $f_s$ , the SCKn frequency requirement can be calculated:

- SCKn frequency:  $f_{\text{SCKn}} = f_s \times \text{total\_number\_of\_bits\_per\_frame}$ ,
- Where  $\text{total\_number\_of\_bits\_per\_frame} = \text{number\_of\_slots} \times \text{number\_of\_bits\_per\_slots}$ .
- The number of slots is selected by writing to the Number of Slots in Frame bit field in the Clock Unit n Control (CLKCTRLn) register:  $\text{number\_of\_slots} = \text{NBSLOTS} + 1$ .
- The number of bits per slot (8, 16, 24, or 32 bit) is selected by writing to the Slot Size bit field in CLKCTRLn: .
- Consequently,  $f_{\text{SCKn}} = 8 \times f_s \times (\text{NBSLOTS} + 1) \times (\text{SLOTSIZE} + 1)$ .

The clock frequencies  $f_{\text{SCKn}}$  and  $f_{\text{MCKn}}$  are derived from the generic clock frequency  $f_{\text{GCLK\_I2S\_n}}$ :

$$\begin{aligned} f_{\text{GCLK\_I2S\_n}} &= f_{\text{SCKn}} \times (\text{CLKCTRLn.MCKDIV} + 1) \\ &= 8 \times f_s \times (\text{NBSLOTS} + 1) \times (\text{SLOTSIZE} + 1) \times (\text{MCKDIV} + 1) \end{aligned}$$

, and

$$f_{\text{GCLK\_I2S\_n}} = f_{\text{MCKn}} \times (\text{MCKOUTDIV} + 1).$$

Substituting the right hand sides of the two last equations yields:

$$\begin{aligned} f_{\text{MCKn}} &= \frac{f_{\text{GCLK\_I2S\_n}}}{\text{MCKOUTDIV}+1} \\ f_{\text{MCKn}} &= \frac{8 \cdot f_s \cdot (\text{SLOTSIZE}+1) \cdot (\text{NBSLOTS}+1) \cdot (\text{MCKDIV}+1)}{\text{MCKOUTDIV}+1} \end{aligned}$$

If a Host Clock output is not required, the GCLK\_I2S generic clock can be configured as SCKn by writing a '0' to CLKCTRLn.MCKDIV. Alternatively, if the frequency of the generic clock is a multiple of the required SCKn frequency, the MCKn-to-SCKn divider can be used with the ratio defined by writing the CLKCTRLn.MCKDIV field.

The FSn pin is used as Word Select in I<sup>2</sup>S format and as Frame Synchronization in TDM format, as described in [37.6.4. I2S Format - Reception and Transmission Sequence with Word Select](#) and [37.6.5. TDM Format - Reception and Transmission Sequence](#), respectively.

### 37.6.2.2 Data Holding Registers

For both the Transmit and the Receive Serializer, the I<sup>2</sup>S user interface includes a Data register (TXDATA and RXDATA, respectively). They are used to access data samples for all data slots.

#### 37.6.2.2.1 Data Reception Mode

In receiver mode, the RXDATA register stores the received data.

When a new data word is available in the RXDATA register, the Receive Ready bit (RXRDYm) in the Interrupt Flag Status and Clear register (INTFLAG) is set. Reading the RXDATA register will clear this bit.

A receive overrun condition occurs if a new data word becomes available before the previous data word has been read from the RXDATA register. Then, the Receive Overrun bit in INTFLAG will be set (INTFLAG.RXORm). This interrupt can be cleared by writing a '1' to it.

#### 37.6.2.2.2 Data Transmission Mode

In Transmitter mode, the TXDATA register contains the data to be transmitted.

When TXDATA is empty, the Transmit Ready bit in the Interrupt Flag Status and Clear register is set (INTFLAG.TXRDYm). Writing to TXDATA will clear this bit.

A transmit underrun condition occurs if data present in TXDATA is sent and no new data is written to TXDATA register before the next time slot. Then, the Transmit Underrun bit in INTFLAG will be set (INTFLAG.TXURm). This interrupt can be cleared by writing a '1' to it. The Transmit Data when Underrun bit in the Tx Serializer Control register (TXCTRL.TXSAME) configures whether a zero data word is transmitted in case of underrun (TXCTRL.TXSAME=0), or the previous data word for the current transmit slot number is transmitted again (TXCTRL.TXSAME=1).

### 37.6.3 Host, Controller, and Client Modes

In Host and Controller modes, the I<sup>2</sup>S provides the Serial Clock, a Word Select/Frame Sync signal and optionally a Host Clock.

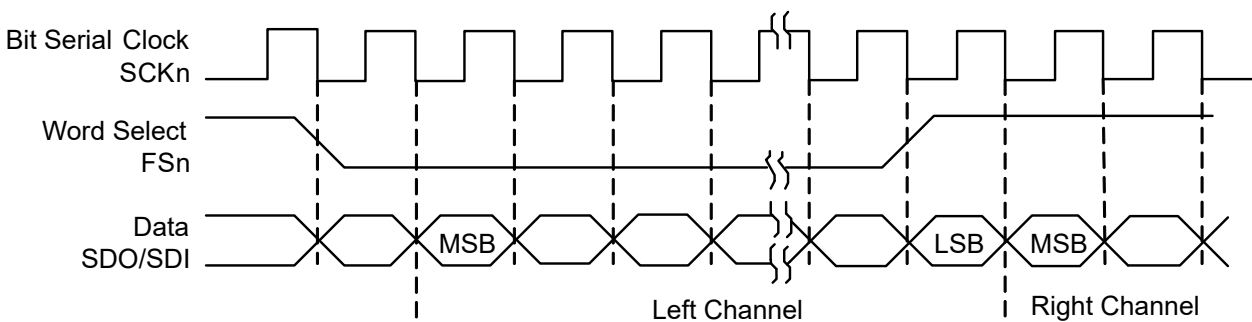
In Controller mode, the I<sup>2</sup>S Serializers are disabled. Only the clocks are enabled and output for external receivers and/or transmitters.

In Client mode, the I<sup>2</sup>S receives the Serial Clock and the Word Select/Frame Sync Signal from an external Host. SCKn and FSn pins are inputs.

### 37.6.4 I<sup>2</sup>S Format - Reception and Transmission Sequence with Word Select

As specified in the I<sup>2</sup>S protocol, data bits are left-adjusted in the Word Select slot, with the MSB transmitted first, starting one clock period after the transition on the Word Select line.

Figure 37-5. I<sup>2</sup>S Reception and Transmission Sequence



Data bits are sent on the falling edge of the Serial Clock and sampled on the rising edge of the Serial Clock. The Word Select line indicates the channel in transmission, a low level for the left channel and a high level for the right channel.

In I<sup>2</sup>S format, typical configurations are described below. These configurations do not list all necessary settings, but only basic ones. Other configuration settings are to be done as per requirement such as clock and DMA configurations.

**Case 1: I<sup>2</sup>S 16-bit compact stereo receiver**

- Slot size configured as 16 bits (CLKCTRL0.SLOTSIZE = 0x1)
- Number of slots configured as 2 (CLKCTRL0.NBSLOTS = 0x1)
- Data size configured as 16-bit compact stereo (RXCTRL.DATASIZE = 0x05)
- Data delay from Frame Sync configured as 1-bit delay (CLKCTRLn.BITDELAY = 0x01)
- Frame Sync Width configured as HALF frame (CLKCTRLn.FSWIDTH = 0x01)

**Case 2: I<sup>2</sup>S 24-bit stereo Transmitterwith 24-bit slot**

- Slot size configured as 24 bits (CLKCTRL0.SLOTSIZE = 0x2)
- Number of slots configured as 2 (CLKCTRL0.NBSLOTS = 0x1)
- Data size configured as 24 bits (TXCTRL.DATASIZE = 0x01)
- Data delay from Frame Sync configured as 1-bit delay (CLKCTRLn.BITDELAY = 0x01)
- Frame Sync Width configured as HALF frame (CLKCTRLn.FSWIDTH = 0x01)

In both cases, it will ensure that Word select signal is 'low level' for the left channel and 'high level' for the right channel.

The length of transmitted words can be chosen among 8, 16, 18, 20, 24, and 32 bits by writing the Data Word Size bit group in the Serializer Control register (RXCTRL.DATASIZE or TXCTRL.DATASIZE, respectively).

If the slot allows for more data bits than the number of bits specified in the respective DATASIZE field, additional bits are appended to the transmitted or received data word as specified in the RXCTRL/TXCTRL.EXTEND field. If the slot allows less data bits than programmed, the extra bits are not transmitted, or received data word is extended based on the EXTEND field value.

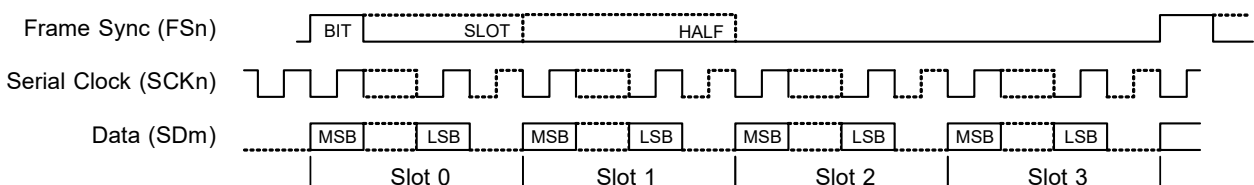
**37.6.5 TDM Format - Reception and Transmission Sequence**

In Time Division Multiplexed (TDM) format, the number of data slots sent or received within each frame will be (CLKCTRLn.NBSLOTS + 1).

By configuring the CLKCTRLn register (CLKCTRLn.FSWIDTH and CLKCTRLn.FSINV), the Frame Sync pulse width and polarity can be modified.

By configuring RXCTRL and/or TXCTRL, data bits can be left-adjusted or right-adjusted in the slot. It can also configure the data transmission/reception with either the MSB or the LSB transmitted/received first and starting the transmission/reception either at the transition of the FSn pin or one clock period after.

**Figure 37-6.** TDM Format Reception and Transmission Sequence



Data bits are sent on the falling edge of the Serial Clock and sampled on the rising edge of the Serial Clock. The FSn pin provides a frame synchronization signal, at the beginning of slot 0. The delay between the frame start and the first data bit is defined by writing the CLKCTRLn.BITDELAY field.

The Frame Sync pulse can be either one SCKn period (BIT), one slot (SLOT), or one half frame (HALF). This selection is done by writing the CLKCTRLn.FSWIDTH field.

The number of slots is selected by writing the CLKCTRLn.NBSLOTS field.

The number of bits in each slot is selected by writing the CLKCTRLn.SLOTSIZE field.

The length of transmitted words can be chosen among 8, 16, 18, 20, 24, and 32 bits by writing the DATASIZE field in the Serializer Control register (RXCTRL and/or TXCTRL).

If the slot allows more data bits than the number of bits specified in the RXCTRL. and/or TXCTRL.DATASIZE bit field, additional bits are appended to the transmitted or received data word as specified in the RXCTRL. and/or TXCTRL.EXTEND bit field. If the slot allows less data bits than programmed, the extra bits are not transmitted, or received data word is extended based on the EXTEND field value.

### 37.6.6 PDM Reception

In Pulse Density Modulation (PDM) reception mode, continuous 1-bit data samples are available on the SDI line on each SCKn rising edge, e.g. by a MEMS microphone with PDM interface. When using two channel PDM microphones, the second one (right channel) is configured to output data on each SCKn falling edge.

For one PDM microphone, the I<sup>2</sup>S controller should be configured in normal Receive mode with one slot and 16- or 32-bit data size, so that 16 or 32 samples of the microphone are stored into each data word.

For two PDM microphones, the I<sup>2</sup>S controller should be configured in PDM2 mode with one slot and 32-bit data size. The Rx Serializer will store 16 samples of each microphone in one half of the data word, with left microphone bits in lower half and right microphone bits in upper half, like in compact stereo format.

Based on oversampling frequency requirement from PDM microphone, the SCKn frequency must be configured in the I<sup>2</sup>S controller.

A microphone that requires a sampling frequency of  $f_s = 48$  kHz and an oversampling frequency of  $f_o = 64 \times f_s$  would require an SCKn frequency of 3.072 MHz.

After selecting a proper frequency for GCLK\_I2S\_n and according Host Clock Division Factor in the Clock Unit n Control register (CLKCTRLn.MCKDIV), SCKn must be selected as per required frequency.

In PDM mode, only the clock and data line (SCKn and SDIn) pins are used.

To configure PDM2 mode, set SLOTSIZE = 0x01 (16-bits), NBSLOTS = 0x00 (1 slots) and RXCTRL.DATASIZE = 0x00 (32-bit).

### 37.6.7 Data Formatting Unit

To allow more flexibility, data words received by the Receive Serializer will be formatted by the Receive Formatting Unit before being stored into the Data Holding register (DATAm). The data words written into DATAm register will be formatted by the Transmit Formatting Unit before transmission by the Transmit Serializer .

The formatting options are defined in RXCTRL and TXCTRL:

- SLOTADJ for left or right justification in the slot
- BITREV for bit reversal
- WORDADJ for left or right justification in the data word
- EXTEND for extension to the word size

## 37.6.8 DMA, Interrupts and Events

**Table 37-2.** Module Request for I<sup>2</sup>S

Condition	DMA request	DMA request is cleared	Interrupt request	Event input/output
Receive Ready	YES	When data is read	YES	
Transmit Ready (Buffer empty)	YES	When data is written	YES	
Receive Overrun			YES	
Transmit Underrun			YES	

### 37.6.8.1 DMA Operation

Each Serializer can be connected either to one single DMAC channel or to one DMAC channel per data slot in Stereo mode. This is selected by writing the RXCTRL/TXCTRL.DMA bit.

**Table 37-3.** I<sup>2</sup>C DMA Request Generation

SERCTRLm.DMA	Mode	Slot Parity	DMA Request Trigger
0	Receiver	all	I2S_DMxAC_ID_RX_m
	Transmitter	all	I2S_DMxAC_ID_TX_m
1	Receiver	even	I2S_DMxAC_ID_RX_m
		odd	I2S_DMxAC_ID_TX_m
	Transmitter	even	I2S_DMxAC_ID_TX_m
		odd	I2S_DMxAC_ID_RX_m

The DMAC reads from the RXDATA register and writes to the TXDATA register for all data slots, successively.

The DMAC transfers may use 32-bit, 16-bit, or 8-bit transactions according to the value of the TXCTRL/RXCTRL.DATASIZE field. 8-bit compact stereo uses 16-bit and 16-bit compact stereo uses 32-bit transactions.

### 37.6.8.2 Interrupts

The I<sup>2</sup>S has the following interrupt sources:

- Receive Ready (RXRDYm): This is an asynchronous interrupt and can be used to wake-up the device from any sleep mode.
- Receive Overrun (RXORM): This is an asynchronous interrupt and can be used to wake-up the device from any sleep mode.
- Transmit Ready (TXRDYm): This is an asynchronous interrupt and can be used to wake-up the device from any sleep mode.
- Transmit Underrun (TXURm): This is an asynchronous interrupt and can be used to wake-up the device from any sleep mode.

Each interrupt source has an interrupt flag associated with it. The interrupt flag in the Interrupt Flag Status and Clear (INTFLAG) register is set when the interrupt condition occurs. Each interrupt can be individually enabled by writing a one to the corresponding bit in the Interrupt Enable Set (INTENSET) register, and disabled by writing a one to the corresponding bit in the Interrupt Enable Clear (INTENCLR) register. An interrupt request is generated when the interrupt flag is set and the corresponding interrupt is enabled. The interrupt request remains active until the interrupt flag is cleared, the interrupt is disabled, or the I<sup>2</sup>S is reset. Refer to the INTFLAG register for details on how to clear interrupt flags. All interrupt requests from the peripheral are ORed together on system level to generate one combined interrupt request to the NVIC. Refer to the [Nested Vector Interrupt Controller](#) for details. The user must read the INTFLAG register to determine which interrupt condition is present.



**Note:** Interrupts must be globally enabled for interrupt requests to be generated. Refer to [Nested Vector Interrupt Controller](#) for details.

### 37.6.9 Sleep Mode Operation

The I<sup>2</sup>S continues to operate in all sleep modes that still provide its clocks.

### 37.6.10 Synchronization

Due to asynchronicity between the main clock domain and the peripheral clock domains, some registers need to be synchronized when written or read.

When executing an operation that requires synchronization, the corresponding Synchronization Busy bit in the Synchronization Busy register (SYNCBUSY) will be set immediately, and cleared when synchronization is complete.

If an operation that requires synchronization is executed while the corresponding SYNCBUSY bit is '1', a peripheral bus error is generated.

The following bits are synchronized when written:

- Software Reset bit in the Control A register (CTRLA.SWRST). SYNCBUSY.SWRST is set to '1' while synchronization is in progress.
- Enable bit in the Control A register (CTRLA.ENABLE). SYNCBUSY.ENABLE is set to '1' while synchronization is in progress.
- Clock Unit x Enable bits in the Control A register (CTRLA.CKENx). SYNCBUSY.CKENx is set to '1' while synchronization is in progress.
- Serializer Enable bits in the Control A register (CTRLA.TXEN and CTRLA.RXEN). SYNCBUSY.TXEN/RXEN is set to '1' while synchronization is in progress.

The following registers require synchronization when read or written:

- Transmit Data register (TXDATA) is Write-Synchronized. SYNCBUSY.TXDATA is set to '1' while synchronization is in progress.
- Receive Data register (RXDATA) is Read-Synchronized. SYNCBUSY.RXDATA is set to '1' while synchronization is in progress.

Synchronization is denoted by the Read-Synchronized or Write-Synchronized property in the register description.

### 37.6.11 Loop-Back Mode

For debugging purposes, the I<sup>2</sup>S can be configured to loop back the Transmitter to the Receiver. Writing a '1' to the Loop-Back Test Mode bit in the Rx Serializer Control register (RXCTRL.RXLOOP) will connect SDO to SDI, so that transmitted data is also received.

Writing RXCTRL.RXLOOP=0 will restore the normal behavior and connection between Receive Serializer and SDI pin input. As for other changes to the Serializers configuration, the Receive Serializer must be disabled before writing the TXCTRL register to update TXCTRL.RXLOOP.

## 37.7 I<sup>2</sup>S Application Examples

The I<sup>2</sup>S can support several serial communication modes used in audio or high-speed serial links. Some standard applications are shown in the following figures.

**Note:** The following examples are not a complete list of serial link applications supported by the I<sup>2</sup>S.

Figure 37-7. Audio Application Block Diagram

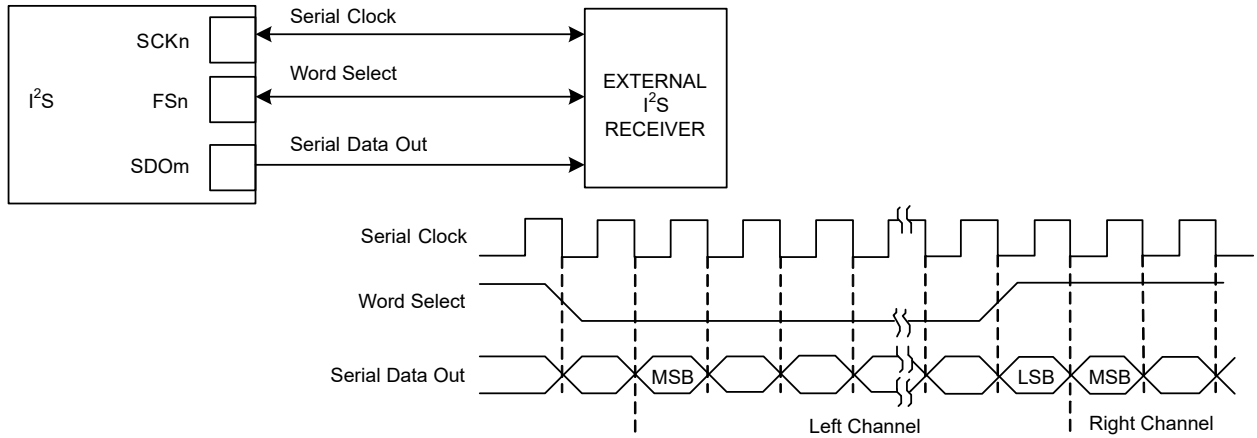
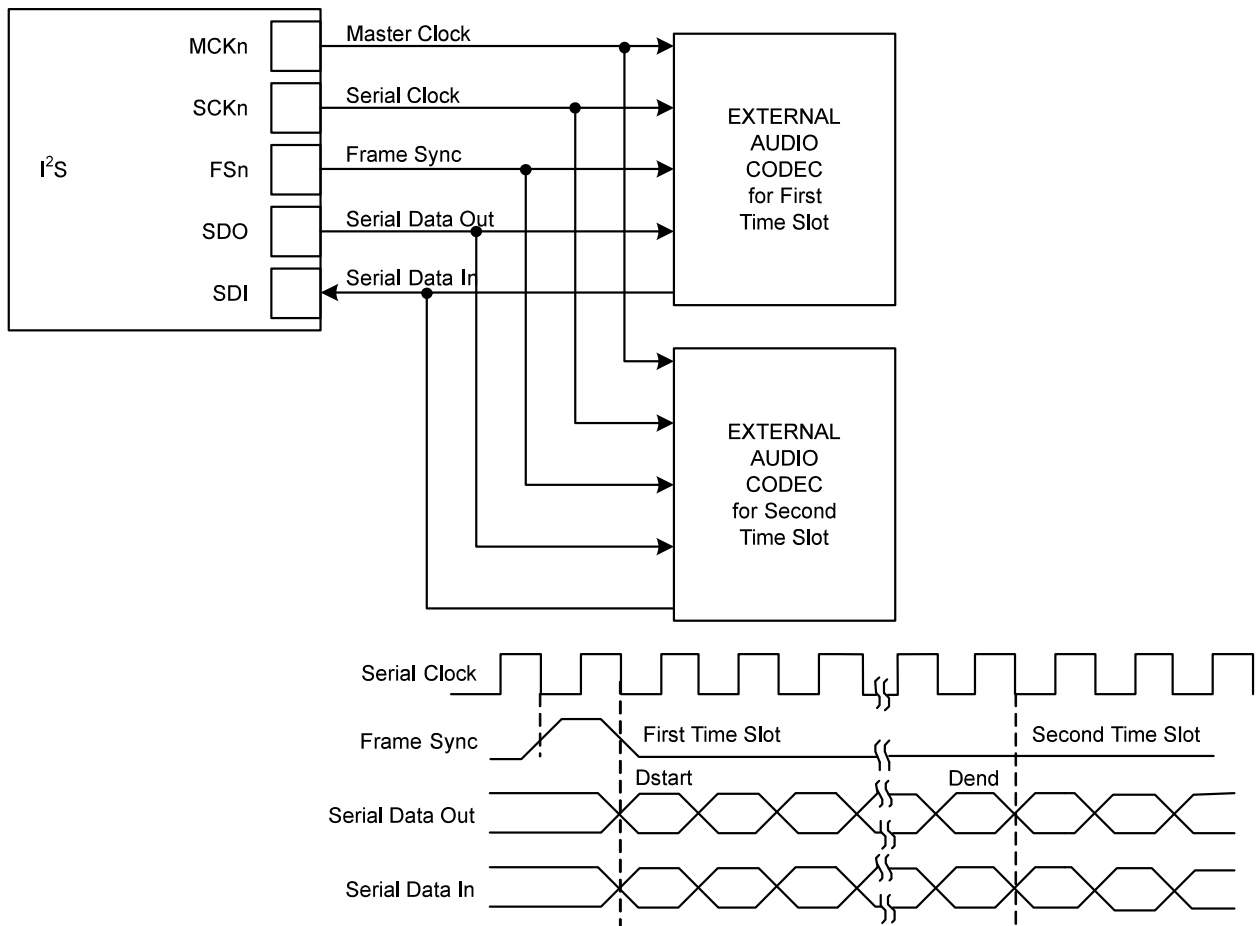
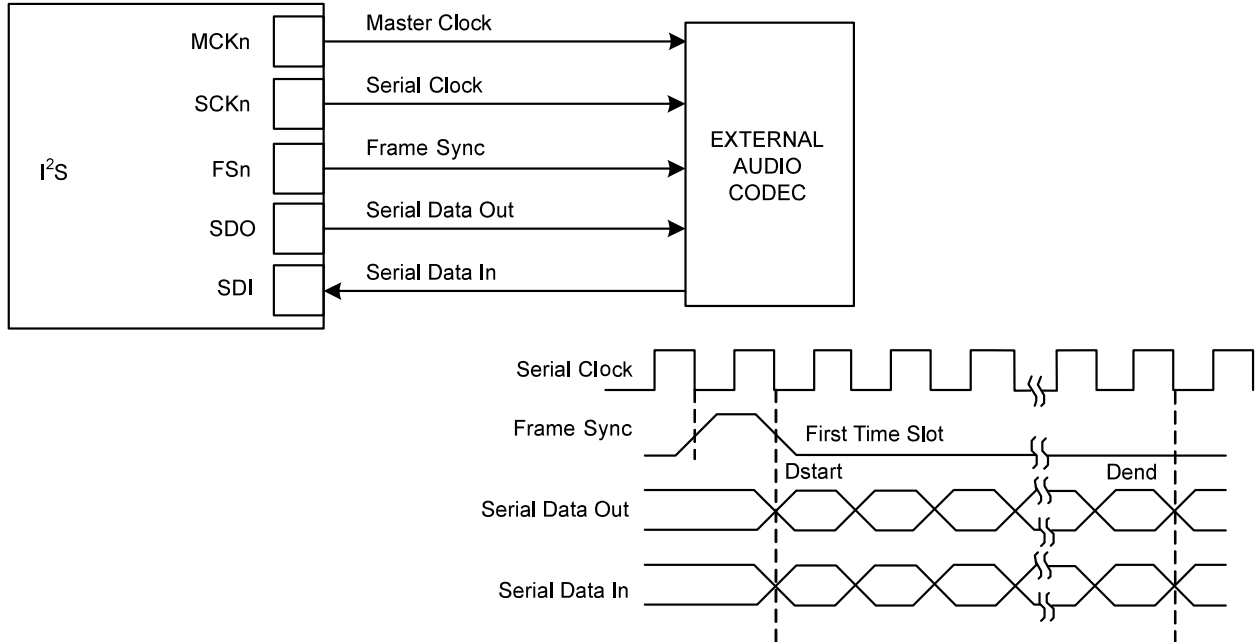


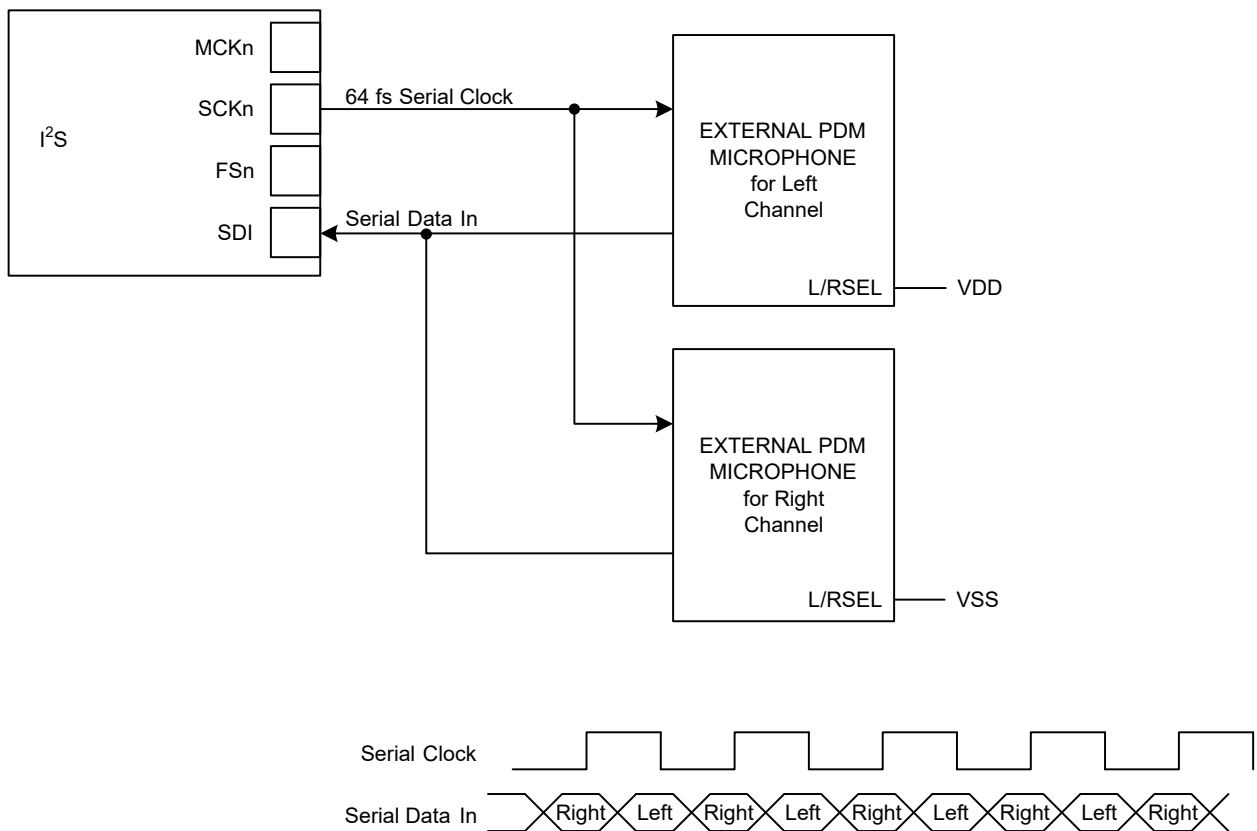
Figure 37-8. Time Slot Application Block Diagram



**Figure 37-9.** Codec Application Block Diagram



**Figure 37-10.** PDM Microphones Application Block Diagram



## 37.8 Register Summary

Offset	Name	Bit Pos.	7	6	5	4	3	2	1	0	
0x00	<b>CTRLA</b>	7:0			RXEN	TXEN	CKEN1	CKEN0	ENABLE	SWRST	
0x01 ... 0x03	Reserved										
0x04	<b>CLKCTRL0</b>	7:0	BITDELAY	FSWIDTH[1:0]		NBSLOTS[2:0]			SLOTSIZE[1:0]		
		15:8	MCKOUTINV	MCKEN	MCKSEL	SCKOUTINV	SCKSEL	FSOUTINV	FSINV	FSSEL	
		23:16			MCKDIV[5:0]						
		31:24			MCKOUTDIV[5:0]						
0x08	<b>CLKCTRL1</b>	7:0	BITDELAY	FSWIDTH[1:0]		NBSLOTS[2:0]			SLOTSIZE[1:0]		
		15:8	MCKOUTINV	MCKEN	MCKSEL	SCKOUTINV	SCKSEL	FSOUTINV	FSINV	FSSEL	
		23:16			MCKDIV[5:0]						
		31:24			MCKOUTDIV[5:0]						
0x0C	<b>INTENCLR</b>	7:0			RXOR1	RXOR0			RXRDY1	RXRDY0	
		15:8			TXUR1	TXUR0			TXRDY1	TXRDY0	
0x0E ... 0x0F	Reserved										
0x10	<b>INTENSET</b>	7:0			RXOR1	RXOR0			RXRDY1	RXRDY0	
		15:8			TXUR1	TXUR0			TXRDY1	TXRDY0	
0x12 ... 0x13	Reserved										
0x14	<b>INTFLAG</b>	7:0			RXOR1	RXOR0			RXRDY1	RXRDY0	
		15:8			TXUR1	TXUR0			TXRDY1	TXRDY0	
0x16 ... 0x17	Reserved										
0x18	<b>SYNCBUSY</b>	7:0			RXEN	TXEN	CKEN1	CKEN0	ENABLE	SWRST	
		15:8							RXDATA	TXDATA	
0x1A ... 0x1F	Reserved										
0x20	<b>TXCTRL</b>	7:0	SLOTADJ			TXSAME	TXDEFAULT[1:0]				
		15:8	BITREV	EXTEND[1:0]		WORDADJ		DATASIZE[2:0]			
		23:16	SLOTDIS7	SLOTDIS6	SLOTDIS5	SLOTDIS4	SLOTDIS3	SLOTDIS2	SLOTDIS1	SLOTDIS0	
		31:24							DMA	MONO	
0x24	<b>RXCTRL</b>	7:0	SLOTADJ		CLKSEL				SERMODE[1:0]		
		15:8	BITREV	EXTEND[1:0]		WORDADJ		DATASIZE[2:0]			
		23:16	SLOTDIS7	SLOTDIS6	SLOTDIS5	SLOTDIS4	SLOTDIS3	SLOTDIS2	SLOTDIS1	SLOTDIS0	
		31:24						RXLOOP	DMA	MONO	
0x28 ... 0x2F	Reserved										
0x30	<b>TXDATA</b>	7:0	DATA[7:0]								
		15:8	DATA[15:8]								
		23:16	DATA[23:16]								
		31:24	DATA[31:24]								
0x34	<b>RXDATA</b>	7:0	DATA[7:0]								
		15:8	DATA[15:8]								
		23:16	DATA[23:16]								
		31:24	DATA[31:24]								

### 37.8.1 Control A

**Name:** CTRLA  
**Offset:** 0x00  
**Reset:** 0x00  
**Property:** PAC Write-Protection

Bit	7	6	5	4	3	2	1	0
Access			R/W	R/W	R/W	R/W	R/W	R/W
Reset			0	0	0	0	0	0

#### Bit 5 – RXEN Rx Serializer Enable

Writing a '0' to this bit will disable the Rx Serializer.  
 Writing a '1' to this bit will enable the Rx Serializer.

Value	Description
0	The Rx Serializer is disabled.
1	The Rx Serializer is enabled.

#### Bit 4 – TXEN Tx Serializer Enable

Writing a '0' to this bit will disable the Tx Serializer.  
 Writing a '1' to this bit will enable the Tx Serializer.

Value	Description
0	The Tx Serializer is disabled.
1	The Tx Serializer is enabled.

#### Bits 2, 3 – CKENx Clock Unit x Enable [x=1..0]

Writing a '0' to this bit will disable the Clock Unit x.  
 Writing a '1' to this bit will enable the Clock Unit x.

Value	Description
0	The Clock Unit x is disabled.
1	The Clock Unit x is enabled.

#### Bit 1 – ENABLE Enable

Writing a '0' to this bit will disable the module.  
 Writing a '1' to this bit will enable the module.

Value	Description
0	The peripheral is disabled.
1	The peripheral is enabled.

#### Bit 0 – SWRST Software Reset

Writing a '0' to this bit has no effect.  
 Writing a '1' to this bit resets all registers to their initial state, and the peripheral will be disabled.  
 Writing a '1' to CTRL.SWRST will always take precedence, meaning that all other writes in the same write-operation will be discarded.  
 The I<sup>2</sup>S generic clocks must be enabled before triggering Software Reset, hence the logic in all clock domains can be reset.

Value	Description
0	There is no reset operation ongoing.
1	The reset operation is ongoing.

### 37.8.2 Clock Unit n Control

**Name:** CLKCTRL  
**Offset:** 0x04 + n\*0x04 [n=0..1]  
**Reset:** 0x00000000  
**Property:** Enable-Protected, PAC Write-Protection

Bit	31	30	29	28	27	26	25	24
	MCKOUTDIV[5:0]							
Access			R/W	R/W	R/W	R/W	R/W	R/W
Reset			0	0	0	0	0	0
Bit	23	22	21	20	19	18	17	16
	MCKDIV[5:0]							
Access			R/W	R/W	R/W	R/W	R/W	R/W
Reset			0	0	0	0	0	0
Bit	15	14	13	12	11	10	9	8
	MCKOUTINV	MCKEN	MCKSEL	SCKOUTINV	SCKSEL	FSOUTINV	FSINV	FSSEL
Access	R/W	R/W	R/W	R/W	R/W	R/W	R/W	R/W
Reset	0	0	0	0	0	0	0	0
Bit	7	6	5	4	3	2	1	0
	BITDELAY	FSWIDTH[1:0]		NBSLOTS[2:0]			SLOTSIZE[1:0]	
Access	R/W	R/W	R/W	R/W	R/W	R/W	R/W	R/W
Reset	0	0	0	0	0	0	0	0

**Bits 29:24 – MCKOUTDIV[5:0]** Host Clock Output Division Factor  
 The generic clock selected by MCKSEL is divided by (MCKOUTDIV + 1) to obtain the Host Clock n output.

**Bits 21:16 – MCKDIV[5:0]** Host Clock Division Factor  
 The Host Clock n is divided by (MCKDIV + 1) to obtain the Serial Clock n.

**Bit 15 – MCKOUTINV** Host Clock Output Invert

Value	Description
0	The Host Clock n is output without inversion.
1	The Host Clock n is inverted before being output.

**Bit 14 – MCKEN** Host Clock Enable

**Note:** MCKEN will not enable the clock output when in Client mode.

Value	Description
0	The Host Clock n division and output is disabled.
1	The Host Clock n division and output is enabled.

**Bit 13 – MCKSEL** Host Clock Select

This field selects the source of the Host Clock n.

MCKSEL	Name	Description
0x0	GCLK	GCLK_I2S_n is used as Host Clock n source
0x1	MCKPIN	MCKn input pin is used as Host Clock n source

**Bit 12 – SCKOUTINV** Serial Clock Output Invert

Value	Description
0	The Serial Clock n is output without inversion.
1	The Serial Clock n is inverted before being output.

#### Bit 11 – SCKSEL Serial Clock Select

This field selects the source of the Serial Clock n.

SCKSEL	Name	Description
0x0	MCKDIV	Divided Host Clock n is used as Serial Clock n source
0x1	SCKPIN	SCKn input pin is used as Serial Clock n source

#### Bit 10 – FSOUTINV Frame Sync Output Invert

Value	Description
0	The Frame Sync n is output without inversion.
1	The Frame Sync n is inverted before being output.

#### Bit 9 – FSINV Frame Sync Invert

Value	Description
0	The Frame Sync n is used without inversion.
1	The Frame Sync n is inverted before being used.

#### Bit 8 – FSSEL Frame Sync Select

This field selects the source of the Frame Sync n.

FSSEL	Name	Description
0x0	SCKDIV	Divided Serial Clock n is used as Frame Sync n source
0x1	FSPIN	FSn input pin is used as Frame Sync n source

#### Bit 7 – BITDELAY Data Delay from Frame Sync

BITDELAY	Name	Description
0x0	LJ	Left Justified (0 Bit Delay)
0x1	I2S	I2S (1 Bit Delay)

#### Bits 6:5 – FSWIDTH[1:0] Frame Sync Width

This field selects the duration of the Frame Sync output pulses.

When not in Burst mode, the Clock unit n operates in continuous mode when enabled, with periodic Frame Sync pulses and Data samples.

In Burst mode, a single Data transfer starts at each Frame Sync pulse; these pulses are 1-bit wide and occur only when a Data transfer is requested. Note that the compact stereo modes (16C and 8C) are not supported in the Burst mode.

**Note:** Compact stereo modes (16C and 8C) are not supported in the Burst mode.

FSWIDTH[1:0]	Name	Description
0x0	SLOT	Frame Sync Pulse is 1 Slot wide (default for I2S protocol)
0x1	HALF	Frame Sync Pulse is half a Frame wide
0x2	BIT	Frame Sync Pulse is 1 Bit wide
0x3	BURST	Clock Unit n operates in Burst mode, with a 1-bit wide Frame Sync pulse per Data sample, only when Data transfer is requested

#### Bits 4:2 – NBSLOTS[2:0] Number of Slots in Frame

Each Frame for Clock Unit n is composed of (NBSLOTS + 1) Slots.

#### Bits 1:0 – SLOTSIZE[1:0] Slot Size

Each Slot for Clock Unit n is composed of a number of bits specified by SLOTSIZE.

SLOTSIZE[1:0]	Name	Description
0x0	8	8-bit Slot for Clock Unit n

.....continued

SLOTSIZE[1:0]	Name	Description
0x1	16	16-bit Slot for Clock Unit n
0x2	24	24-bit Slot for Clock Unit n
0x3	32	32-bit Slot for Clock Unit n



### 37.8.3 Interrupt Enable Clear

**Name:** INTENCLR  
**Offset:** 0x0C  
**Reset:** 0x0000  
**Property:** PAC Write-Protection

Bit	15	14	13	12	11	10	9	8
			TXUR1	TXUR0			TXRDY1	TXRDY0
Access			R/W	R/W			R/W	R/W
Reset			0	0			0	0
Bit	7	6	5	4	3	2	1	0
			RXOR1	RXOR0			RXRDY1	RXRDY0
Access			R/W	R/W			R/W	R/W
Reset			0	0			0	0

#### Bits 12, 13 – TXURx Transmit Underrun x Interrupt Enable [x=1..0]

Writing a '0' to this bit has no effect.

Writing a '1' to this bit will clear the Transmit Underrun x Interrupt Enable bit, which disables the Transmit Underrun x interrupt.

Value	Description
0	The Transmit Underrun x interrupt is disabled.
1	The Transmit Underrun x interrupt is enabled.

#### Bits 8, 9 – TXRDYx Transmit Ready x Interrupt Enable [x=1..0]

Writing a '0' to this bit has no effect.

Writing a '1' to this bit will clear the Transmit Ready x Interrupt Enable bit, which disables the Transmit Ready x interrupt.

Value	Description
0	The Transmit Ready x interrupt is disabled.
1	The Transmit Ready x interrupt is enabled.

#### Bits 4, 5 – RXORx Receive Overrun x Interrupt Enable [x=1..0]

Writing a '0' to this bit has no effect.

Writing a '1' to this bit will clear the Receive Overrun x Interrupt Enable bit, which disables the Receive Overrun x interrupt.

Value	Description
0	The Receive Overrun x interrupt is disabled.
1	The Receive Overrun x interrupt is enabled.

#### Bits 0, 1 – RXRDYx Receive Ready x Interrupt Enable [x=1..0]

Writing a '0' to this bit has no effect.

Writing a '1' to this bit will clear the Receive Ready x Interrupt Enable bit, which disables the Receive Ready x interrupt.

Value	Description
0	The Receive Ready x interrupt is disabled.
1	The Receive Ready x interrupt is enabled.

### 37.8.4 Interrupt Enable Set

**Name:** INTENSET  
**Offset:** 0x10  
**Reset:** 0x0000  
**Property:** PAC Write-Protection

Bit	15	14	13	12	11	10	9	8
			TXUR1	TXUR0			TXRDY1	TXRDY0
Access			R/W	R/W			R/W	R/W
Reset			0	0			0	0
Bit	7	6	5	4	3	2	1	0
			RXOR1	RXOR0			RXRDY1	RXRDY0
Access			R/W	R/W			R/W	R/W
Reset			0	0			0	0

#### Bits 12, 13 – TXURx Transmit Underrun x Interrupt Enable [x=1..0]

Writing a '0' to this bit has no effect.

Writing a '1' to this bit will set the Transmit Underrun Interrupt Enable bit, which enables the Transmit Underrun interrupt.

Value	Description
0	The Transmit Underrun interrupt is disabled.
1	The Transmit Underrun interrupt is enabled.

#### Bits 8, 9 – TXRDYx Transmit Ready x Interrupt Enable [x=1..0]

Writing a '0' to this bit has no effect.

Writing a '1' to this bit will set the Transmit Ready Interrupt Enable bit, which enables the Transmit Ready interrupt.

Value	Description
0	The Transmit Ready interrupt is disabled.
1	The Transmit Ready interrupt is enabled.

#### Bits 4, 5 – RXORx Receive Overrun x Interrupt Enable [x=1..0]

Writing a '0' to this bit has no effect.

Writing a '1' to this bit will set the Receive Overrun Interrupt Enable bit, which enables the Receive Overrun interrupt.

Value	Description
0	The Receive Overrun interrupt is disabled.
1	The Receive Overrun interrupt is enabled.

#### Bits 0, 1 – RXRDYx Receive Ready x Interrupt Enable [x=1..0]

Writing a '0' to this bit has no effect.

Writing a '1' to this bit will set the Receive Ready Interrupt Enable bit, which enables the Receive Ready interrupt.

Value	Description
0	The Receive Ready interrupt is disabled.
1	The Receive Ready interrupt is enabled.

### 37.8.5 Interrupt Flag Status and Clear

**Name:** INTFLAG  
**Offset:** 0x14  
**Reset:** 0x0000  
**Property:** -

Bit	15	14	13	12	11	10	9	8
			TXUR1	TXUR0			TXRDY1	TXRDY0
Access			R/W	R/W			R/W	R/W
Reset			0	0			0	0
Bit	7	6	5	4	3	2	1	0
			RXOR1	RXOR0			RXRDY1	RXRDY0
Access			R/W	R/W			R/W	R/W
Reset			0	0			0	0

#### Bits 12, 13 – TXURx Transmit Underrun x [x=1..0]

This flag is cleared by writing a '1' to it.

This flag is set when a Transmit Underrun condition occurs in Sequencer x, and will generate an interrupt request if INTENCLR/SET.TXURx is set to '1'.

Writing a '0' to this bit has no effect.

Writing a '1' to this bit will clear the Transmit Underrun x interrupt flag.

#### Bits 8, 9 – TXRDYx Transmit Ready x [x=1..0]

This flag is cleared by writing to DATAx register or writing a '1' to it.

This flag is set when Sequencer x is ready to accept a new data word to be transmitted, and will generate an interrupt request if INTENCLR/SET.TXRDYx is set to '1'.

Writing a '0' to this bit has no effect.

Writing a '1' to this bit will clear the Transmit Ready x interrupt flag.

#### Bits 4, 5 – RXORx Receive Overrun x [x=1..0]

This flag is cleared by writing a '1' to it.

This flag is set when a Receive Overrun condition occurs in Sequencer x, and will generate an interrupt request if INTENCLR/SET.RXORx is set to '1'.

Writing a '0' to this bit has no effect.

Writing a '1' to this bit will clear the Receive Overrun x interrupt flag.

#### Bits 0, 1 – RXRDYx Receive Ready x [x=1..0]

This flag is cleared by reading from DATAx register or writing a '1' to it.

This flag is set when a Sequencer x has received a new data word, and will generate an interrupt request if INTENCLR/SET.RXRDYx is set to '1'.

Writing a '0' to this bit has no effect.

Writing a '1' to this bit will clear the Receive Ready x interrupt flag.

### 37.8.6 Synchronization Busy

**Name:** SYNCBUSY  
**Offset:** 0x18  
**Reset:** 0x0000  
**Property:** -

Bit	15	14	13	12	11	10	9	8
							RXDATA	TXDATA
Access							R	R
Reset							0	0
Bit	7	6	5	4	3	2	1	0
			RXEN	TXEN	CKEN1	CKEN0	ENABLE	SWRST
Access			R	R	R	R	R	R
Reset			0	0	0	0	0	0

#### Bit 9 – RXDATA Rx Data Synchronization Status

This bit is cleared when the synchronization of the Rx DATA Holding (RXDATA) register between the clock domains is complete.

This bit is set when the synchronization of the Rx DATA Holding (RXDATA) register between the clock domains is started.

#### Bit 8 – TXDATA Tx Data Synchronization Status

This bit is cleared when the synchronization of the Tx DATA Holding (TXDATA) register between the clock domains is complete.

This bit is set when the synchronization of the Tx DATA Holding (TXDATA) register between the clock domains is started.

#### Bit 5 – RXEN Rx Serializer Enable Synchronization Status

This bit is cleared when the synchronization of the CTRLA.RXEN bit between the clock domains is complete.

This bit is set when the synchronization of the CTRLA.RXEN bit between the clock domains is started.

#### Bit 4 – TXEN Tx Serializer Enable Synchronization Status

This bit is cleared when the synchronization of the CTRLA.TXEN bit between the clock domains is complete.

This bit is set when the synchronization of the CTRLA.TXEN bit between the clock domains is started.

#### Bits 2, 3 – CKENx Clock Unit x Enable Synchronization Status [x=1..0]

Bit CKENx is cleared when the synchronization of the CTRLA.CKENx bit between the clock domains is complete.

Bit CKENx is set when the synchronization of the CTRLA.CKENx bit between the clock domains is started.

#### Bit 1 – ENABLE Enable Synchronization Status

This bit is cleared when the synchronization of the CTRLA.ENABLE bit between the clock domains is complete.

This bit is set when the synchronization of the CTRLA.ENABLE bit between the clock domains is started.

#### Bit 0 – SWRST Software Reset Synchronization Status

This bit is cleared when the synchronization of the CTRLA.SWRST bit between the clock domains is complete.

This bit is set when the synchronization of the CTRLA.SWRST bit between the clock domains is started.

### 37.8.7 Tx Serializer Control

**Name:** TXCTRL  
**Offset:** 0x20  
**Reset:** 0x00000000  
**Property:** Enable-Protected, Write-Protection

Bit	31	30	29	28	27	26	25	24
							DMA	MONO
Access							R/W	R/W
Reset							0	0
Bit	23	22	21	20	19	18	17	16
	SLOTDIS7	SLOTDIS6	SLOTDIS5	SLOTDIS4	SLOTDIS3	SLOTDIS2	SLOTDIS1	SLOTDIS0
Access	R/W	R/W	R/W	R/W	R/W	R/W	R/W	R/W
Reset	0	0	0	0	0	0	0	0
Bit	15	14	13	12	11	10	9	8
	BITREV	EXTEND[1:0]		WORDADJ		DATASIZE[2:0]		
Access	R/W	R/W	R/W	R/W		R/W	R/W	R/W
Reset	0	0	0	0		0	0	0
Bit	7	6	5	4	3	2	1	0
	SLOTADJ			TXSAME	TXDEFAULT[1:0]			
Access	R/W			R/W	R/W	R/W		
Reset	0			0	0	0		

#### Bit 25 – DMA Single or Multiple DMA Channels

This bit selects whether even-numbered and odd-numbered slots use separate DMA channels or the same DMA channel.

DMA	Name	Description
0x0	SINGLE	Single DMA channel
0x1	MULTIPLE	One DMA channel per data channel

#### Bit 24 – MONO Mono Mode.

MONO	Name	Description
0x0	STEREO	Normal mode
0x1	MONO	Left channel data is duplicated to right channel

#### Bits 16, 17, 18, 19, 20, 21, 22, 23 – SLOTDISx Slot x Disabled for this Serializer [x=7..0]

This field allows disabling some slots in each transmit frame:

Value	Description
0	Slot x is used for data transfer.
1	Slot x is not used for data transfer and will be output as specified in the TXDEFAULT field.

#### Bit 15 – BITREV Data Formatting Bit Reverse

This bit allows changing the order of data bits in the word in the Formatting Unit.

BITREV	Name	Description
0x0	MSBIT	Transfer Data Most Significant Bit (MSB) first (default for I2S protocol)
0x1	LSBIT	Transfer Data Least Significant Bit (LSB) first

### Bits 14:13 – EXTEND[1:0] Data Formatting Bit Extension

This field defines the bit value used to extend data samples in the Formatting Unit.

EXTEND[1:0]	Name	Description
0x0	ZERO	Extend with zeros
0x1	ONE	Extend with ones
0x2	MSBIT	Extend with Most Significant Bit
0x3	LSBIT	Extend with Least Significant Bit

### Bit 12 – WORDADJ Data Word Formatting Adjust

This field defines left or right adjustment of data samples in the word in the Formatting Unit. for details.

WORDADJ	Name	Description
0x0	RIGHT	Data is right adjusted in word
0x1	LEFT	Data is left adjusted in word

### Bits 10:8 – DATASIZE[2:0] Data Word Size

This field defines the number of bits in each data sample. For 8-bit compact stereo, two 8-bit data samples are packed in bits 15 to 0 of the DATAm register. For 16-bit compact stereo, two 16-bit data samples are packed in bits 31 to 0 of the DATAm register.

DATASIZE[2:0]	Name	Description
0x0	32	32 bits
0x1	24	24 bits
0x2	20	20 bits
0x3	18	18 bits
0x4	16	16 bits
0x5	16C	16 bits compact stereo
0x6	8	8 bits
0x7	8C	8 bits compact stereo

### Bit 7 – SLOTADJ Data Slot Formatting Adjust

This field defines left or right adjustment of data samples in the slot.

SLOTADJ	Name	Description
0x0	RIGHT	Data is right adjusted in slot
0x1	LEFT	Data is left adjusted in slot

### Bit 4 – TXSAME Transmit Data when Underrun.

TXSAME	Name	Description
0x0	ZERO	Zero data transmitted in case of underrun
0x1	SAME	Last data transmitted in case of underrun

### Bits 3:2 – TXDEFAULT[1:0] Line Default Line when Slot Disabled

This field defines the default value driven on the SDn output pin during all disabled Slots.

TXDEFAULT[1:0]	Name	Description
0x0	ZERO	Output Default Value is 0
0x1	ONE	Output Default Value is 1
0x2		Reserved
0x3	HIZ	Output Default Value is high impedance

### 37.8.8 Rx Serializer Control

**Name:** RXCTRL  
**Offset:** 0x24  
**Reset:** 0x00000000  
**Property:** Enable-Protected, PAC Write-Protection

Bit	31	30	29	28	27	26	25	24
						RXLOOP	DMA	MONO
Access						R/W	R/W	R/W
Reset						0	0	0
Bit	23	22	21	20	19	18	17	16
	SLOTDIS7	SLOTDIS6	SLOTDIS5	SLOTDIS4	SLOTDIS3	SLOTDIS2	SLOTDIS1	SLOTDIS0
Access	R/W	R/W	R/W	R/W	R/W	R/W	R/W	R/W
Reset	0	0	0	0	0	0	0	0
Bit	15	14	13	12	11	10	9	8
	BITREV	EXTEND[1:0]		WORDADJ		DATASIZE[2:0]		
Access	R/W	R/W	R/W	R/W		R/W	R/W	R/W
Reset	0	0	0	0		0	0	0
Bit	7	6	5	4	3	2	1	0
	SLOTADJ		CLKSEL				SERMODE[1:0]	
Access	R/W		R/W				R/W	R/W
Reset	0		0				0	0

#### Bit 26 – RXLOOP Loop-back Test Mode

This bit enables a loop-back test mode:

Value	Description
0	Each Receiver uses its SDn pin as input (default mode).
1	Receiver uses as input the transmitter output of the other Serializer in the pair: e.g. SD1 for SD0 or SD0 for SD1.

#### Bit 25 – DMA Single or Multiple DMA Channels

This bit selects whether even- and odd-numbered slots use separate DMA channels or the same DMA channel.

DMA	Name	Description
0x0	SINGLE	Single DMA channel
0x1	MULTIPLE	One DMA channel per data channel

#### Bit 24 – MONO Mono Mode.

MONO	Name	Description
0x0	STEREO	Normal mode
0x1	MONO	Left channel data is duplicated to right channel

#### Bits 16, 17, 18, 19, 20, 21, 22, 23 – SLOTDISx Slot x Disabled for this Serializer [x=7..0]

This field allows disabling some slots in each transmit frame:

Value	Description
0	Slot x is used for data transfer.
1	Slot x is not used for data transfer and will be output as specified in the TXDEFAULT field.



**Bit 15 – BITREV** Data Formatting Bit Reverse

This bit allows changing the order of data bits in the word in the Formatting Unit.

BITREV	Name	Description
0x0	MSBIT	Transfer Data Most Significant Bit (MSB) first (default for I2S protocol)
0x1	LSBIT	Transfer Data Least Significant Bit (LSB) first

**Bits 14:13 – EXTEND[1:0]** Data Formatting Bit Extension

This field defines the bit value used to extend data samples in the Formatting Unit.

EXTEND[1:0]	Name	Description
0x0	ZERO	Extend with zeros
0x1	ONE	Extend with ones
0x2	MSBIT	Extend with Most Significant Bit
0x3	LSBIT	Extend with Least Significant Bit

**Bit 12 – WORDADJ** Data Word Formatting Adjust

This field defines left or right adjustment of data samples in the word in the Formatting Unit. for details.

WORDADJ	Name	Description
0x0	RIGHT	Data is right adjusted in word
0x1	LEFT	Data is left adjusted in word

**Bits 10:8 – DATASIZE[2:0]** Data Word Size

This field defines the number of bits in each data sample. For 8-bit compact stereo, two 8-bit data samples are packed in bits 15 to 0 of the DATAm register. For 16-bit compact stereo, two 16-bit data samples are packed in bits 31 to 0 of the DATAm register.

DATASIZE[2:0]	Name	Description
0x0	32	32 bits
0x1	24	24 bits
0x2	20	20 bits
0x3	18	18 bits
0x4	16	16 bits
0x5	16C	16 bits compact stereo
0x6	8	8 bits
0x7	8C	8 bits compact stereo

**Bit 7 – SLOTADJ** Data Slot Formatting Adjust

This field defines left or right adjustment of data samples in the slot.

SLOTADJ	Name	Description
0x0	RIGHT	Data is right adjusted in slot
0x1	LEFT	Data is left adjusted in slot

**Bit 5 – CLKSEL** Clock Unit Selection.

CLKSEL	Name	Description
0x0	CLK0	Use Clock Unit 0
0x1	CLK1	Use Clock Unit 1

**Bits 1:0 – SERMODE[1:0]** Serializer Mode.

SERMODE[1:0]	Name	Description
0x0	RX	Receive
0x1		Reserved
0x2	PDM2	Receive one PDM data on each serial clock edge

.....continued

SERMODE[1:0]	Name	Description
0x3		Reserved

### 37.8.9 Tx Data

**Name:** TXDATA  
**Offset:** 0x30  
**Reset:** 0x00000000  
**Property:** Write-Synchronized

**Note:** This register is write-synchronized: SYNCBUSY.TXDATA must be checked to ensure the TXDATA register synchronization is complete.

Bit	31	30	29	28	27	26	25	24
	DATA[31:24]							
Access	R/W	R/W	R/W	R/W	R/W	R/W	R/W	R/W
Reset	0	0	0	0	0	0	0	0
Bit	23	22	21	20	19	18	17	16
	DATA[23:16]							
Access	R/W	R/W	R/W	R/W	R/W	R/W	R/W	R/W
Reset	0	0	0	0	0	0	0	0
Bit	15	14	13	12	11	10	9	8
	DATA[15:8]							
Access	R/W	R/W	R/W	R/W	R/W	R/W	R/W	R/W
Reset	0	0	0	0	0	0	0	0
Bit	7	6	5	4	3	2	1	0
	DATA[7:0]							
Access	R/W	R/W	R/W	R/W	R/W	R/W	R/W	R/W
Reset	0	0	0	0	0	0	0	0

#### Bits 31:0 – DATA[31:0] Sample Data

This register is used to transfer data to the Tx Serializer.

Data samples written to TXDATA register will be sent to Tx Serializer for transmission, through the Transmit Formatting Unit that will apply the formatting specified in the TXCTRL register.

### 37.8.10 Rx Data

**Name:** RXDATA  
**Offset:** 0x34  
**Reset:** 0x00000000  
**Property:** Read-Synchronized

**Note:** This register is read-synchronized: SYNCBUSY.RXDATA must be checked to ensure the RXDATA register synchronization is complete.

Bit	31	30	29	28	27	26	25	24
	DATA[31:24]							
Access	R/W	R/W	R/W	R/W	R/W	R/W	R/W	R/W
Reset	0	0	0	0	0	0	0	0
Bit	23	22	21	20	19	18	17	16
	DATA[23:16]							
Access	R/W	R/W	R/W	R/W	R/W	R/W	R/W	R/W
Reset	0	0	0	0	0	0	0	0
Bit	15	14	13	12	11	10	9	8
	DATA[15:8]							
Access	R/W	R/W	R/W	R/W	R/W	R/W	R/W	R/W
Reset	0	0	0	0	0	0	0	0
Bit	7	6	5	4	3	2	1	0
	DATA[7:0]							
Access	R/W	R/W	R/W	R/W	R/W	R/W	R/W	R/W
Reset	0	0	0	0	0	0	0	0

#### Bits 31:0 – DATA[31:0] Sample Data

This register is used to transfer data from the Rx Serializer.

Data samples received by Rx Serializer will be available for reading from RXDATA register, through the Receive Formatting Unit, according to formatting information for Rx Serializer in the RXCTRL register.

## 38. Control Area Network (CAN)

### 38.1 Overview

The Control Area Network (CAN) performs communication according to ISO 11898-1:2015 (Bosch CAN specification 2.0 part A,B, ISO CAN FD). Message storage is intended to be a single- or dual-ported Message RAM outside of the module.

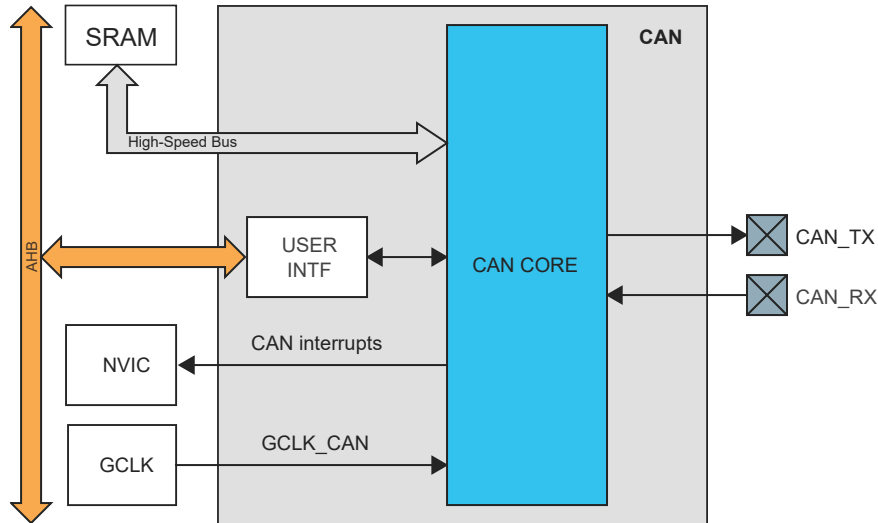
### 38.2 Features

The following are key features of the CAN module:

- Conform with CAN protocol version 2.0 part A, B and ISO 11898-1:2015
- Up to two Controller Area Network CAN interfaces
  - Supporting CAN2.0 A/B and CAN-FD (ISO 11898-1:2015)
- CAN FD with up to 64 data bytes supported
- CAN Error Logging
- AUTOSAR optimized
- SAE J1939 optimized
- Two configurable Receive FIFOs
- Separate signaling on reception of High-Priority Messages
- Up to 64 dedicated Receive Buffers and up to 32 dedicated Transmit Buffers
- Configurable Transmit FIFO, Transmit Queue, Transmit Event FIFO
- Direct Message RAM access for CPU
- Programmable Loop-Back Test mode
- Maskable module interrupts
- Power-down support; Debug on CAN support
- Transfer rates:
  - 1 Mb/s for CAN 2.0 mode
  - 10 Mb/s for CAN-FD mode

### 38.3 Block Diagram

Figure 38-1. CAN Block Diagram



### 38.4 Signal Description

Table 38-1. Signal Description

Signal	Description	Type
CAN_TX	CAN transmit	Digital output
CAN_RX	CAN receive	Digital input

One signal can be mapped to one of several pins. Refer to the [Pinout and Packaging](#) chapter for more details.

### 38.5 Peripheral Dependencies

<b>Peripheral Name</b>	CAN0, CAN1 - Control Area Network
<b>Base Address</b>	CAN0 : 0x4200_0000 (Peripheral Bus C) CAN1 : 0x4200_0400 (Peripheral Bus C)
<b>NVIC IRQ Index:Source</b>	CAN0 : 78 : LINE0, LINE1 CAN1 : 79 : LINE0, LINE1
<b>MCLK APB Clock (1)</b>	CLK_CAN0_AHB, Enabled ,AHBMASK.CAN0 CLK_CAN1_AHB, Enabled, AHBMASK.CAN1
<b>GCLK Peripheral Channel Index:Clock Name (2)</b>	27 : GCLK_CAN0 28 : GCLK_CAN1
<b>PAC Peripheral Identifier (PAC.WRCTRL)</b>	Not supported by PAC
<b>DMA Trigger Index:Source (DMAC.CHCTRLAK,k=0,1,...31)</b>	CAN0: 20 : Debug Request (DEBUG) CAN1: 21 : Debug Request (DEBUG)
<b>Notes:</b>	
1.	Clock Name, Default State, Mask Field.
2.	See GCLK.PCHCTRLm Register, where m = Index.

#### 38.5.1 Power Management

The CAN continues to operate in idle0 Sleep mode, but cannot operate in idle2 and standby Sleep modes. Consequently, the CAN interrupts can only be used to wake up the device from idle0 Sleep mode. Refer to the [Power Manager](#) chapter for details on the different sleep modes.

The CAN module has its own Low-Power mode. The clock sources cannot be halted while the CAN is enabled unless this mode is used. Refer to the [Sleep Mode Controller](#) for additional information.

### 38.5.2 Clocks

An AHB clock (CLK\_CAN\_AHB) is required to clock the CAN. This clock can be configured in the [Main Clock peripheral \(MCLK\)](#) before using the CAN, and the default state of CLK\_CAN\_AHB can be found in the MCLK.AHBMASK register.

A generic clock (GCLK\_CAN) is required to clock the CAN. This clock must be configured and enabled in the [Generic Clock Controller](#) before using the CAN.

**Note:** On-Demand Clock request is not supported by the CAN. Ensure to clear the ONDEMAND bit to zero for the oscillator source that provides the GCLK to the CAN.

This generic clock is asynchronous to the bus clock (CLK\_CAN\_AHB). Due to this asynchronicity, writes to certain registers will require synchronization between the clock domains.

### 38.5.3 DMA

The CAN has a built-in Direct Memory Access (DMA) and will read/write data to/from the system RAM when a CAN transaction takes place. No CPU or [DMA Controller \(DMAC\)](#) resources are required.

The DMAC can be used for debug messages functionality.

## 38.6 Functional Description

### 38.6.1 Principle of Operation

The CAN performs communication according to ISO 11898-1:2015 (identical to Bosch CAN protocol specification 2.0 part A,B, ISO CAN FD).

The Message storage is intended to be a single- or dual-ported Message RAM outside the module. It is connected to the CAN via AHB.

All functions concerning the handling of messages are implemented by the Rx Handler and the Tx Handler. The Rx Handler manages message acceptance filtering, the transfer of received messages from the CAN Core to the Message RAM as well as providing receive message status information. The Tx Handler is responsible for the transfer of transmit messages from the Message RAM to the CAN Core as well as providing transmit status information.

Acceptance filtering is implemented by a combination of up to 128 filter elements where each one can be configured as a range, as a bit mask, or as a dedicated ID filter.

### 38.6.2 Operating Modes

#### 38.6.2.1 Software Initialization

Software initialization is started by setting bit CCCR.INIT, either by software or by a hardware reset, when an uncorrected bit error was detected in the Message RAM, or by going Bus\_Off. While CCCR.INIT is set, message transfer from and to the CAN bus is stopped, the status of the CAN bus output CAN\_TX is "recessive" (HIGH). The counters of the Error Management Logic EML are unchanged. Setting CCCR.INIT does not change any configuration register. Resetting CCCR.INIT finishes the software initialization. Afterwards the Bit Stream Processor BSP synchronizes itself to the data transfer on the CAN bus by waiting for the occurrence of a sequence of 11 consecutive "recessive" bits (= Bus\_Idle) before it can take part in bus activities and start the message transfer.

Access to the CAN configuration registers is only enabled when both bits CCCR.INIT and CCCR.CCE are set (protected write).

CCCR.CCE can only be set/reset while CCCR.INIT = '1'. CCCR.CCE is automatically reset when CCCR.INIT is reset.

The following registers are reset when CCCR.CCE is set

- HPMS - High Priority Message Status
- RXF0S - Rx FIFO 0 Status
- RXF1S - Rx FIFO 1 Status
- TXFQS - Tx FIFO/Queue Status
- TXBRP - Tx Buffer Request Pending
- TXBTO - Tx Buffer Transmission Occurred
- TXBCF - Tx Buffer Cancellation Finished
- TXEFS - Tx Event FIFO Status

The Timeout Counter value TOCV.TOC is preset to the value configured by TOCC.TOP when CCCR.CCE is set.

In addition the state machines of the Tx Handler and Rx Handler are held in idle state while CCCR.CCE = '1'.

The following registers are only writable while CCCR.CCE = '0'

- TXBAR - Tx Buffer Add Request
- TXBCR - Tx Buffer Cancellation Request

CCCR.TEST and CCCR.MON can only be set by the CPU while CCCR.INIT = '1' and CCCR.CCE = '1'. Both bits may be reset at any time. CCCR.DAR can only be set/reset while CCCR.INIT = '1' and CCCR.CCE = '1'.

### 38.6.2.2 Normal Operation

Once the CAN is initialized and CCCR.INIT is reset to '0', the CAN synchronizes itself to the CAN bus and is ready for communication.

After passing the acceptance filtering, received messages including Message ID and DLC are stored into a dedicated Rx Buffer or into Rx FIFO0 or Rx FIFO1.

For messages to be transmitted dedicated Tx Buffers and/or a Tx FIFO or a Tx Queue can be initialized or updated. Automated transmission on reception of remote frames is not implemented.

### 38.6.2.3 CAN FD Operation

There are two variants in the CAN FD frame format, first the CAN FD frame without bit rate switching where the data field of a CAN frame may be longer than 8 bytes. The second variant is the CAN FD frame where control field, data field, and CRC field of a CAN frame are transmitted with a higher bit rate than the beginning and the end of the frame.

The previously reserved bit in CAN frames with 11-bit identifiers and the first previously reserved bit in CAN frames with 29-bit identifiers will now be decoded as FDF bit. FDF = recessive signifies a CAN FD frame, FDF = dominant signifies a Classic CAN frame. In a CAN FD frame, the two bits following FDF, res and BRS, decide whether the bit rate inside of this CAN FD frame is switched. A CAN FD bit rate switch is signified by res = dominant and BRS = recessive. The coding of res = recessive is reserved for future expansion of the protocol. In case the CAN receives a frame with FDF = recessive and res = recessive, it will signal a Protocol Exception Event by setting bit PSR.PXE. When Protocol Exception Handling is enabled (CCCR.PXHD = '0'), this causes the operation state to change from Receiver (PSR.ACT = "10") to synchronizing on CAN communication (PSR.ACT = "00") at the next sample point. In case Protocol Exception Handling is disabled (CCCR.PXHD = '1'), the CAN will treat a recessive res bit as a form error and will respond with an error frame.

CAN FD operation is enabled by programming CCCR.FDOE. In case CCCR.FDOE = '1', transmission and reception of CAN FD frames is enabled. Transmission and reception of Classic CAN frames is always possible. Whether a CAN FD frame or a Classic CAN frame is transmitted can be configured via bit FDF in the respective Tx Buffer element. With CCCR.FDOE = '0', received frames are



interpreted as Classic CAN frames, which leads to the transmission of an error frame when receiving a CAN FD frame. When CAN FD operation is disabled, no CAN FD frames are transmitted even if bit FDF of a Tx Buffer element is set. CCCR.FDOE and CCCR.BRSE can only be changed while CCCR.INIT and CCCR.CCE are both set.

With CCCR.FDOE = '0', the setting of bits FDF and BRS is ignored and frames are transmitted in Classic CAN format. With CCCR.FDOE = '1' and CCCR.BRSE = '0', only bit FDF of a Tx Buffer element is evaluated. With CCCR.FDOE = '1' and CCCR.BRSE = '1', transmission of CAN FD frames with bit rate switching is enabled. All Tx Buffer elements with bits FDF and BRS set are transmitted in CAN FD format with bit rate switching.

A mode change during CAN operation is only recommended under the following conditions:

- The failure rate in the CAN FD data phase is significantly higher than in the CAN FD arbitration phase. In this case disable the CAN FD bit rate switching option for transmissions.
- During system startup all nodes are transmitting Classic CAN messages until it is verified that they are able to communicate in CAN FD format. If this is true, all nodes switch to CAN FD operation.
- Wake-up messages in CAN Partial Networking have to be transmitted in Classic CAN format.
- End-of-line programming in case not all nodes are CAN FD capable. Non CAN FD nodes are held in silent mode until programming has completed. Then all nodes switch back to Classic CAN communication.

In the CAN FD format, the coding of the DLC differs from the standard CAN format. The DLC codes 0 to 8 have the same coding as in standard CAN, the codes 9 to 15, which in standard CAN all code a data field of 8 bytes, are coded according to the table below.

**Table 38-2.** Coding of DLC in CAN FD

DLC	9	10	11	12	13	14	15
Number of Data Bytes	12	16	20	24	32	48	64

In CAN FD frames, the bit timing will be switched inside the frame, after the BRS (Bit Rate Switch) bit, if this bit is recessive. Before the BRS bit, in the CAN FD arbitration phase, the nominal CAN bit timing is used as defined by the Nominal Bit Timing & Prescaler Register NBTP. In the following CAN FD data phase, the fast CAN bit timing is used as defined by the Data Bit Timing & Prescaler Register DBTP. The bit timing is switched back from the fast timing at the CRC delimiter or when an error is detected, whichever occurs first.

The maximum configurable bit rate in the CAN FD data phase depends on the CAN clock frequency (GCLK\_CAN). Example: with a CAN clock frequency of 20MHz and the shortest configurable bit time of  $4 t_q$ , the bit rate in the data phase is 5 Mbit/s.

In both data frame formats, CAN FD long and CAN FD fast, the value of the bit ESI (Error Status Indicator) is determined by the transmitter's error state at the start of the transmission. If the transmitter is error passive, ESI is transmitted recessive, else it is transmitted dominant.

### 38.6.2.4 Transceiver Delay Compensation

During the data phase of a CAN FD transmission only one node is transmitting, all others are receivers. The length of the bus line has no impact. When transmitting via pin CAN\_TX the CAN receives the transmitted data from its local CAN transceiver via pin CAN\_RX. The received data is delayed by the CAN transceiver's loop delay. In case this delay is greater than TSEG1 (time segment before sample point), a bit error is detected. In order to enable a data phase bit time that is even shorter than the transceiver loop delay, the delay compensation is introduced. Without transceiver delay compensation, the bit rate in the data phase of a CAN FD frame is limited by the transceivers loop delay.

Description

The CAN's protocol unit has implemented a delay compensation mechanism to compensate the transmitter delay, thereby enabling transmission with higher bit rates during the CAN FD data phase independent of the delay of a specific CAN transceiver.

To check for bit errors during the data phase of transmitting nodes, the delayed transmit data is compared against the received data at the Secondary Sample Point SSP. If a bit error is detected, the transmitter will react on this bit error at the next following regular sample point. During arbitration phase the delay compensation is always disabled.

The transmitter delay compensation enables configurations where the data bit time is shorter than the transmitter delay, it is described in detail in the new ISO11898-1. It is enabled by setting bit DBTP.TDC.

The received bit is compared against the transmitted bit at the SSP. The SSP position is defined as the sum of the measured delay from the CAN's transmit output CAN\_TX through the transceiver to the receive input CAN\_RX plus the transmitter delay compensation offset as configured by TDCR.TDCO. The transmitter delay compensation offset is used to adjust the position of the SSP inside the received bit (e.g. half of the bit time in the data phase). The position of the secondary sample point is rounded down to the next integer number of mtq.

PSR.TDCV shows the actual transmitter delay compensation value. PSR.TDCV is cleared when CCCR.INIT is set and is updated at each transmission of an FD frame while DBTP.TDC is set.

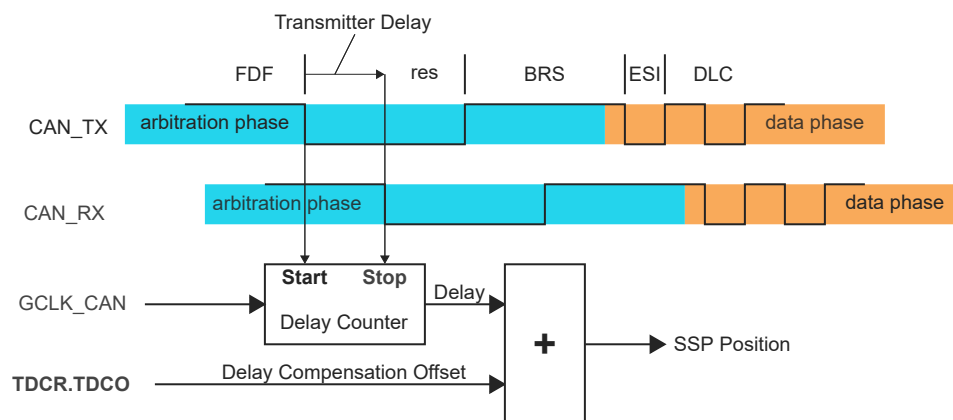
The following boundary conditions have to be considered for the transmitter delay compensation implemented in the CAN:

- The sum of the measured delay from CAN\_TX to CAN\_RX and the configured transceiver delay compensation offset FBTP.TDCO has to be less than 6 bit times in the data phase.
- The sum of the measured delay from CAN\_TX to CAN\_RX and the configured transceiver delay compensation offset FBTP.TDCO has to be less or equal to 127 mtq. In case this sum exceeds 127 mtq, the maximum value of 127 mtq is used for transceiver delay compensation.
- The data phase ends at the sample point of the CRC delimiter, that stops checking of receive bits at the SSPs.

#### Transmitter Delay Compensation Measurement

If transmitter delay compensation is enabled by programming DBTP.TDC = '1', the measurement is started within each transmitted CAN FD frame at the falling edge of bit FDF to bit res. The measurement is stopped when this edge is seen at the receive input CAN\_TX of the transmitter. The resolution of this measurement is one mtq.

**Figure 38-2.** Transceiver delay measurement



To avoid that a dominant glitch inside the received FDF bit ends the delay compensation measurement before the falling edge of the received res bit, resulting in a too early SSP position, the use of a transmitter delay compensation filter window can be enabled by programming TDCR.TDCF. This defines a minimum value for the SSP position. Dominant edges of CAN\_RX, that would result in an earlier SSP position are ignored for transmitter delay measurement. The measurement is stopped when the SSP position is at least TDCR.TDCF AND CAN\_RX is low.

### 38.6.2.5 Restricted Operation Mode

In Restricted Operation Mode the node is able to receive data and remote frames and to give acknowledge to valid frames, but it does not send data frames, remote frames, active error frames, or overload frames. In case of an error condition or overload condition, it does not send dominant bits, instead it waits for the occurrence of bus idle condition to resynchronize itself to the CAN communication. The error counters (ECR.REC, ECR.TEC) are frozen while Error Logging (ECR.CEL) is still incremented. The CPU can set the CAN into Restricted Operation Mode by setting bit CCCR.ASM. The bit can only be set by the CPU when both CCCR.CCE and CCCR.INIT are set to '1'. The bit can be reset by the CPU at any time.

Restricted Operation Mode is automatically entered when the Tx Handler was not able to read data from the Message RAM in time. To leave Restricted Operation Mode, the CPU has to reset CCCR.ASM.

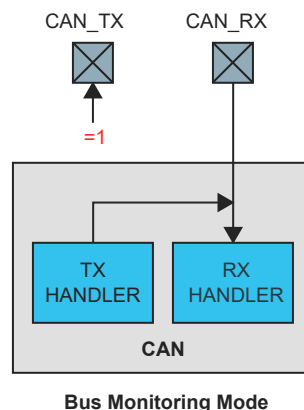
The Restricted Operation Mode can be used in applications that adapt themselves to different CAN bit rates. In this case the application tests different bit rates and leaves the Restricted Operation Mode after it has received a valid frame.

### 38.6.2.6 Bus Monitoring Mode

The CAN is set in Bus Monitoring Mode by programming CCCR.MON to '1'. In Bus Monitoring Mode (see ISO 11898-1, 10.12 Bus monitoring), the CAN is able to receive valid data frames and valid remote frames, but cannot start a transmission. In this mode, it sends only recessive bits on the CAN bus. If the CAN is required to send a dominant bit (ACK bit, overload flag, active error flag), the bit is rerouted internally so that the CAN monitors this dominant bit, although the CAN bus may remain in recessive state. In Bus Monitoring Mode register TXBRP is held in reset state.

The Bus Monitoring Mode can be used to analyze the traffic on a CAN bus without affecting it by the transmission of dominant bits. The figure below shows the connection of signals CAN\_TX and CAN\_RX to the CAN in Bus Monitoring Mode.

Figure 38-3. Pin Control in Bus Monitoring Mode



### 38.6.2.7 Disabled Automatic Retransmission

According to the CAN Specification (see ISO 11898-1, 6.3.3 Recovery Management), the CAN provides means for automatic retransmission of frames that have lost arbitration or that have been disturbed by errors during transmission. By default automatic retransmission is enabled. To support time-

triggered communication as described in ISO 11898-1, chapter 9.2, the automatic retransmission may be disabled via CCCR.DAR.

#### Frame Transmission in DAR Mode

In DAR mode all transmissions are automatically cancelled after they started on the CAN bus. A Tx Buffer's Tx Request Pending bit TXBRP.TRPx is reset after successful transmission, when a transmission has not yet been started at the point of cancellation, has been aborted due to lost arbitration, or when an error occurred during frame transmission.

- Successful transmission:
  - Corresponding Tx Buffer Transmission Occurred bit TXBTO.TOx set
  - Corresponding Tx Buffer Cancellation Finished bit TXBCF.CFx not set
- Successful transmission in spite of cancellation:
  - Corresponding Tx Buffer Transmission Occurred bit TXBTO.TOx set
  - Corresponding Tx Buffer Cancellation Finished bit TXBCF.CFx set
- Arbitration lost or frame transmission disturbed:
  - Corresponding Tx Buffer Transmission Occurred bit TXBTO.TOx not set
  - Corresponding Tx Buffer Cancellation Finished bit TXBCF.CFx set

In case of a successful frame transmission, and if storage of Tx events is enabled, a Tx Event FIFO element is written with Event Type ET = "10" (transmission in spite of cancellation).

### 38.6.2.8 Test Modes

To enable write access to register TEST, bit CCCR.TEST has to be set to '1'. This allows the configuration of the test modes and test functions.

Four output functions are available for the CAN transmit pin CAN\_TX by programming TEST.TX. Additionally to its default function – the serial data output – it can drive the CAN Sample Point signal to monitor the CAN's bit timing and it can drive constant dominant or recessive values. The actual value at pin CAN\_RX can be read from TEST.RX. Both functions can be used to check the CAN bus' physical layer.

Due to the synchronization mechanism between GCLK\_CAN and GCLK\_CAN\_APB domains, there may be a delay of several GCLK\_CAN\_APB periods between writing to TEST.TX until the new configuration is visible at output pin CAN\_TX. This applies also when reading input pin CAN\_RX via TEST.RX.

Note: Test modes should be used for production tests or self test only. The software control for pin CAN\_TX interferes with all CAN protocol functions. It is not recommended to use test modes for application.

#### External Loop Back Mode

The CAN can be set in External Loop Back Mode by programming TEST.LBCK to '1'. In Loop Back Mode, the CAN treats its own transmitted messages as received messages and stores them (if they pass acceptance filtering) into an Rx Buffer or an Rx FIFO. The figure below shows the connection of signals CAN\_TX and CAN\_RX to the CAN in External Loop Back Mode.

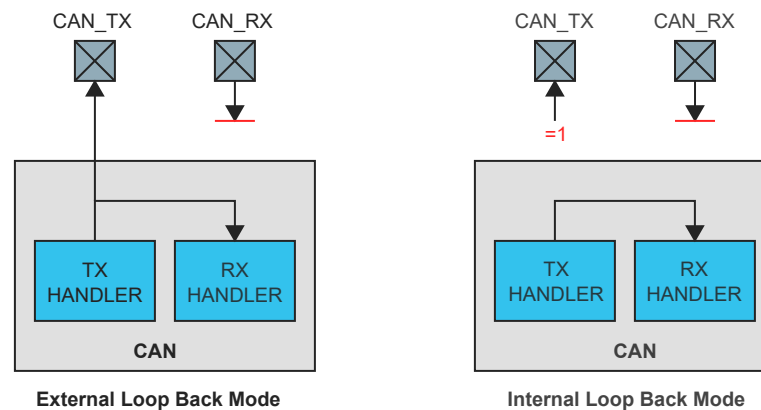
This mode is provided for hardware self-test. To be independent from external stimulation, the CAN ignores acknowledge errors (recessive bit sampled in the acknowledge slot of a data/remote frame) in Loop Back Mode. In this mode the CAN performs an internal feedback from its Tx output to its Rx input. The actual value of the CAN\_RX input pin is disregarded by the CAN. The transmitted messages can be monitored at the CAN\_TX pin.

#### Internal Loop Back Mode

Internal Loop Back Mode is entered by programming bits TEST.LBCK and CCCR.MON to '1'. This mode can be used for a "Hot Selftest", meaning the CAN can be tested without affecting a running

CAN system connected to the pins CAN\_TX and CAN\_RX. In this mode pin CAN\_RX is disconnected from the CAN and pin CAN\_TX is held recessive. The figure below shows the connection of CAN\_TX and CAN\_RX to the CAN in case of Internal Loop Back Mode.

**Figure 38-4.** Pin Control in Loop Back Modes



### 38.6.3 Timestamp Generation

For timestamp generation, the CAN supplies a 16-bit wrap-around counter. A prescaler TSCC.TCP can be configured to clock the counter in multiples of CAN bit times (1...16). The counter is readable through TSCV.TSC. A write access to TSCV register resets the counter to '0'. When the timestamp counter wraps around interrupt flag IR.TSW is set.

On start of frame reception/transmission the counter value is captured and stored into the timestamp section of an Rx Buffer/Rx FIFO (RXTS[15:0]) or Tx Event FIFO (TXTS[15:0]) element.

**Note:** In CANFD mode, if the bit rate switching is turned on (that is, CCCR.BRSE = 1), this counter can not be used.

### 38.6.4 Timeout Counter

To signal timeout conditions for Rx FIFO 0, Rx FIFO 1, and the Tx Event FIFO the CAN supplies a 16-bit Timeout Counter. It operates as down-counter and uses the same prescaler controlled by TSCC.TCP as the Timestamp Counter. The Timeout Counter is configured via register TOCC. The actual counter value can be read from TOCV.TOC. The Timeout Counter can only be started while CCCR.INIT = '0'. It is stopped when CCCR.INIT = '1', e.g. when the CAN enters Bus\_Off state.

The operation mode is selected by TOCC.TOS. When operating in Continuous Mode, the counter starts when CCCR.INIT is reset. A write to TOCV presets the counter to the value configured by TOCC.TOP and continues down-counting.

When the Timeout Counter is controlled by one of the FIFOs, an empty FIFO presets the counter to the value configured by TOCC.TOP. Down-counting is started when the first FIFO element is stored. Writing to TOCV has no effect.

When the counter reaches zero, interrupt flag IR.TOO is set. In Continuous Mode, the counter is immediately restarted at TOCC.TOP.

Note: The clock signal for the Timeout Counter is derived from the CAN Core's sample point signal. Therefore the point in time where the Timeout Counter is decremented may vary due to the synchronization / re-synchronization mechanism of the CAN Core. If the baud rate switch feature in CAN FD is used, the timeout counter is clocked differently in arbitration and data field.

### 38.6.5 Rx Handling

The Rx Handler controls the acceptance filtering, the transfer of received messages to the Rx Buffers or to one of the two Rx FIFOs, as well as the Rx FIFO's Put and Get Indices.

#### 38.6.5.1 Acceptance Filtering

The CAN offers the possibility to configure two sets of acceptance filters, one for standard identifiers and one for extended identifiers. These filters can be assigned to an Rx Buffer or to Rx FIFO 0,1. For acceptance filtering each list of filters is executed from element #0 until the first matching element. Acceptance filtering stops at the first matching element. The following filter elements are not evaluated for this message.

The main features are:

- Each filter element can be configured as
  - range filter (from - to)
  - filter for one or two dedicated IDs
  - classic bit mask filter
- Each filter element is configurable for acceptance or rejection filtering
- Each filter element can be enabled / disabled individually
- Filters are checked sequentially, execution stops with the first matching filter element

Related configuration registers are:

- Global Filter Configuration GFC
- Standard ID Filter Configuration SIDFC
- Extended ID Filter Configuration XIDFC
- Extended ID AND Mask XIDAM

Depending on the configuration of the filter element (SFEC/EFEC) a match triggers one of the following actions:

- Store received frame in FIFO 0 or FIFO 1
- Store received frame in Rx Buffer
- Store received frame in Rx Buffer and generate pulse at filter event pin
- Reject received frame
- Set High Priority Message interrupt flag IR.HPM
- Set High Priority Message interrupt flag IR.HPM and store received frame in FIFO 0 or FIFO 1

Acceptance filtering is started after the complete identifier has been received. After acceptance filtering has completed, and if a matching Rx Buffer or Rx FIFO has been found, the Message Handler starts writing the received message data in portions of 32 bit to the matching Rx Buffer or Rx FIFO. If the CAN protocol controller has detected an error condition (e.g. CRC error), this message is discarded with the following impact on the affected Rx Buffer or Rx FIFO:

#### Rx Buffer

New Data flag of matching Rx Buffer is not set, but Rx Buffer (partly) overwritten with received data. For error type see PSR.LEC respectively PSR.FLEC.

#### Rx FIFO

Put index of matching Rx FIFO is not updated, but related Rx FIFO element (partly) overwritten with received data. For error type see PSR.LEC respectively PSR.FLEC. In case the matching Rx FIFO is operated in overwrite mode, the boundary conditions described in [Rx FIFO Overwrite Mode](#) have to be considered.

Note: When an accepted message is written to one of the two Rx FIFOs, or into an Rx Buffer, the unmodified received identifier is stored independent of the filter(s) used. The result of the acceptance filter process is strongly depending on the sequence of configured filter elements.

### Range Filter

The filter matches for all received frames with Message IDs in the range defined by SF1ID/SF2ID for standard frames or EF1ID/EF2ID for extended frames.

There are two possibilities when range filtering is used together with extended frames:

- EFT = "00" The Message ID of received frames is AND'ed with the Extended ID AND Mask (XIDAM) before the range filter is applied
- EFT = "11" The Extended ID AND Mask (XIDAM) is not used for range filtering

### Filter for specific IDs

A filter element can be configured to filter for one or two specific Message IDs. To filter for one specific Message ID, the filter element has to be configured with SF1ID = SF2ID resp. EF1ID = EF2ID.

### Classic Bit Mask Filter

Classic bit mask filtering is intended to filter groups of Message IDs by masking single bits of a received Message ID. With classic bit mask filtering SF1ID/EF1ID is used as Message ID filter, while SF2ID/EF2ID is used as filter mask.

A zero bit at the filter mask will mask out the corresponding bit position of the configured ID filter, e.g. the value of the received Message ID at that bit position is not relevant for acceptance filtering. Only those bits of the received Message ID where the corresponding mask bits are one are relevant for acceptance filtering.

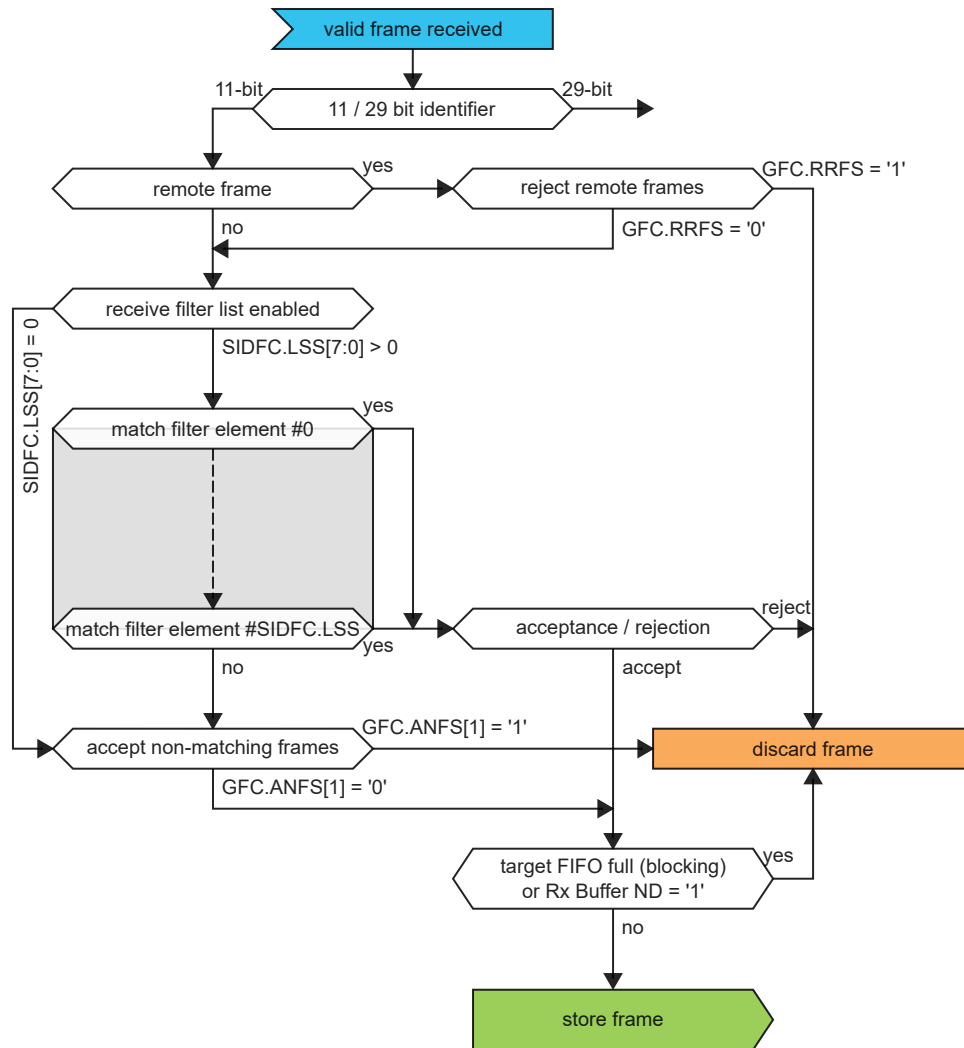
In case all mask bits are one, a match occurs only when the received Message ID and the Message ID filter are identical. If all mask bits are zero, all Message IDs match.

### Standard Message ID Filtering

The figure below shows the flow for standard Message ID (11-bit Identifier) filtering. The Standard Message ID Filter element is described in [38.7.5. Standard Message ID Filter Element](#).

Controlled by the Global Filter Configuration GFC and the Standard ID Filter Configuration SIDFC Message ID, Remote Transmission Request bit (RTR), and the Identifier Extension bit (IDE) of received frames are compared against the list of configured filter elements.

Figure 38-5. Standard Message ID Filtering



### Extended Message ID Filtering

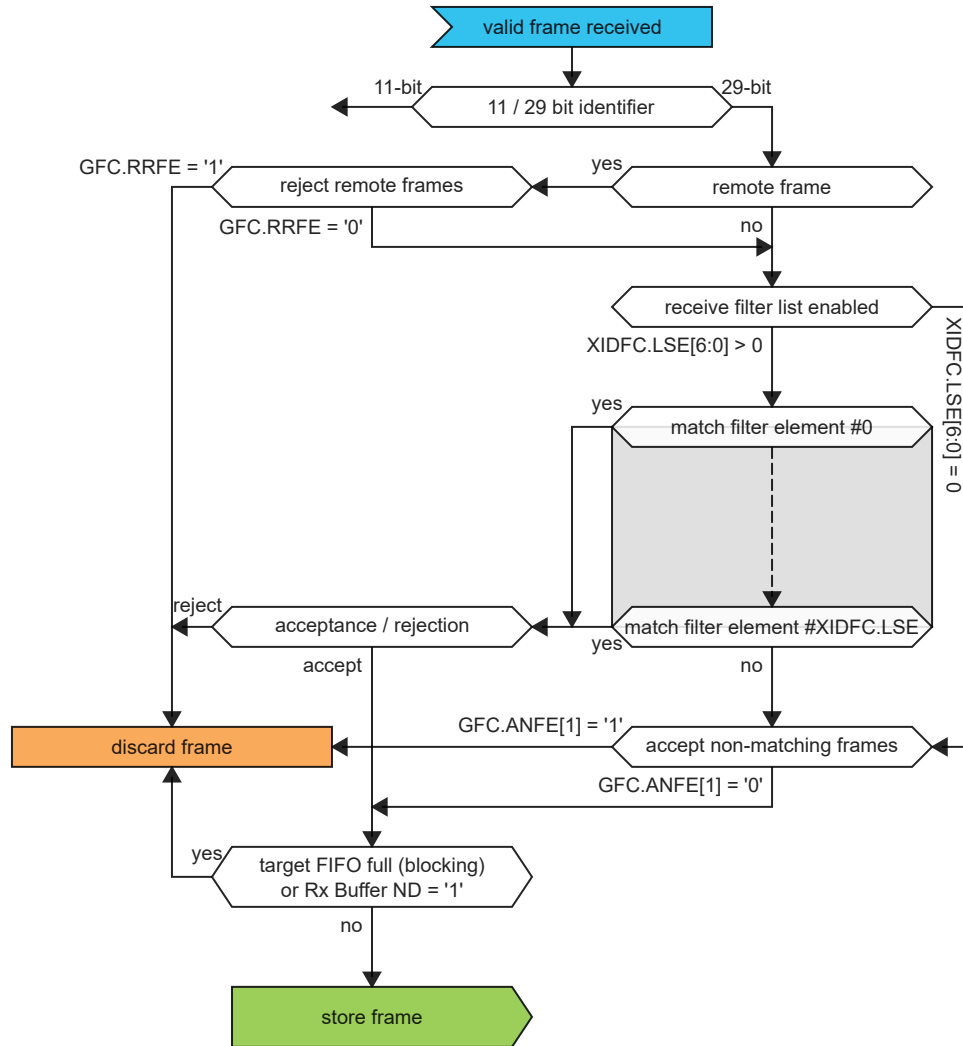
The figure below shows the flow for extended Message ID (29-bit Identifier) filtering. The Extended Message ID Filter element is described in [38.7.6. Extended Message ID Filter Element](#).

Controlled by the Global Filter Configuration GFC and the Extended ID Filter Configuration XIDFC Message ID, Remote Transmission Request bit (RTR), and the Identifier Extension bit (IDE) of received frames are compared against the list of configured filter elements.

The Extended ID AND Mask XIDAM is AND'ed with the received identifier before the filter list is executed.



Figure 38-6. Extended Message ID Filtering



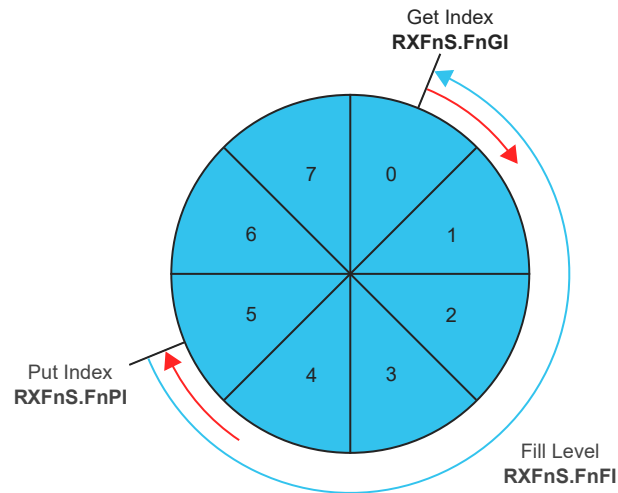
### 38.6.5.2 Rx FIFOs

Rx FIFO 0 and Rx FIFO 1 can be configured to hold up to 64 elements each. Configuration of the two Rx FIFOs is done via registers RXF0C and RXF1C.

Received messages that passed acceptance filtering are transferred to the Rx FIFO as configured by the matching filter element. For a description of the filter mechanisms available for Rx FIFO 0 and Rx FIFO 1 see [38.6.5.1. Acceptance Filtering](#). The Rx FIFO element is described in [38.7.2. Rx Buffer and FIFO Element](#).

To avoid an Rx FIFO overflow, the Rx FIFO watermark can be used. When the Rx FIFO fill level reaches the Rx FIFO watermark configured by RXFnC.FnWM, interrupt flag IR.RFnW is set. When the Rx FIFO Put Index reaches the Rx FIFO Get Index an Rx FIFO Full condition is signalled by RXFnS.FnF. In addition interrupt flag IR.RFnF is set.

Figure 38-7. Rx FIFO Status



When reading from an Rx FIFO, Rx FIFO Get Index  $RxFnS.FnGI \cdot \text{FIFO Element Size}$  has to be added to the corresponding Rx FIFO start address  $RxFnC.FnSA$ .

Table 38-3. Rx Buffer / FIFO Element Size

$RXESC.RBDS[2:0]$ $RXESC.FnDS[2:0]$	Data Field [bytes]	FIFO Element Size [RAM words]
000	8	4
001	12	5
010	16	6
011	20	7
100	24	8
101	32	10
110	48	14
111	64	18

### Rx FIFO Blocking Mode

The Rx FIFO blocking mode is configured by  $RxFnC.FnOM = '0'$ . This is the default operation mode for the Rx FIFOs.

When an Rx FIFO full condition is reached ( $RxFnS.FnPI = RxFnS.FnGI$ ), no further messages are written to the corresponding Rx FIFO until at least one message has been read out and the Rx FIFO Get Index has been incremented. An Rx FIFO full condition is signaled by  $RxFnS.FnF = '1'$ . In addition interrupt flag  $IR.RFnF$  is set.

In case a message is received while the corresponding Rx FIFO is full, this message is discarded and the message lost condition is signalled by  $RxFnS.RFnL = '1'$ . In addition interrupt flag  $IR.RFnL$  is set.

### Rx FIFO Overwrite Mode

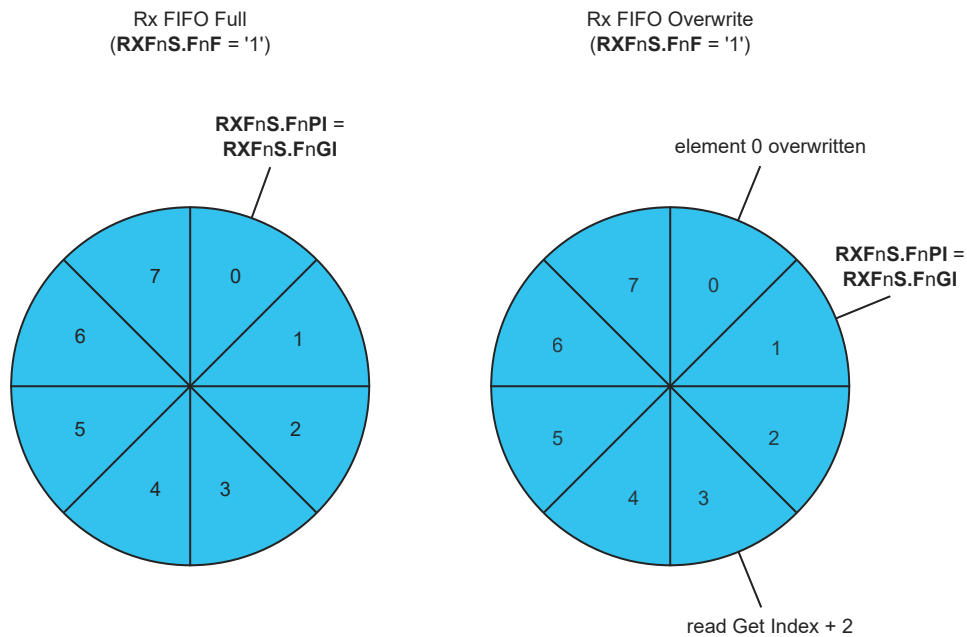
The Rx FIFO overwrite mode is configured by  $RxFnC.FnOM = '1'$ .

When an Rx FIFO full condition ( $RxFnS.FnPI = RxFnS.FnGI$ ) is signaled by  $RxFnS.FnF = '1'$ , the next message accepted for the FIFO will overwrite the oldest FIFO message. Put and get index are both incremented by one.

When an Rx FIFO is operated in overwrite mode and an Rx FIFO full condition is signaled, reading of the Rx FIFO elements should start at least at get index + 1. The reason for that is, that it might

happen, that a received message is written to the Message RAM (put index) while the CPU is reading from the Message RAM (get index). In this case inconsistent data may be read from the respective Rx FIFO element. Adding an offset to the get index when reading from the Rx FIFO avoids this problem. The offset depends on how fast the CPU accesses the Rx FIFO. The figure below shows an offset of two with respect to the get index when reading the Rx FIFO. In this case the two messages stored in element 1 and 2 are lost.

**Figure 38-8.** Rx FIFO Overflow Handling



After reading from the Rx FIFO, the number of the last element read has to be written to the Rx FIFO Acknowledge Index RXFnA.FnA. This increments the get index to that element number. In case the put index has not been incremented to this Rx FIFO element, the Rx FIFO full condition is reset (RXFnS.FnF = '0').

### 38.6.5.3 Dedicated Rx Buffers

The CAN supports up to 64 dedicated Rx Buffers. The start address of the dedicated Rx Buffer section is configured via RXBC.RBSA.

For each Rx Buffer a Standard or Extended Message ID Filter Element with SFEC / EFEC = "111" and SFID2 / EFID2[10:9] = "00" has to be configured (see [38.7.5. Standard Message ID Filter Element](#) and [38.7.6. Extended Message ID Filter Element](#)).

After a received message has been accepted by a filter element, the message is stored into the Rx Buffer in the Message RAM referenced by the filter element. The format is the same as for an Rx FIFO element. In addition the flag IR.DRX (Message stored in Dedicated Rx Buffer) in the interrupt register is set.

**Table 38-4.** Example Filter Configuration for Rx Buffers

Filter Element	SFID1[10:0] / EFID1[28:0]	SFID2[10:9] / EFID2[10:9]	SFID2[5:0] / EFID2[5:0]
0	ID message 1	00	00 0000
1	ID message 2	00	00 0001
2	ID message 3	00	00 0010

After the last word of a matching received message has been written to the Message RAM, the respective New Data flag in register NDAT1, NDAT2 is set. As long as the New Data flag is set, the

respective Rx Buffer is locked against updates from received matching frames. The New Data flags have to be reset by the CPU by writing a '1' to the respective bit position.

While an Rx Buffer's New Data flag is set, a Message ID Filter Element referencing this specific Rx Buffer will not match, causing the acceptance filtering to continue. Following Message ID Filter Elements may cause the received message to be stored into another Rx Buffer, or into an Rx FIFO, or the message may be rejected, depending on filter configuration.

### Rx Buffer Handling

- Reset interrupt flag IR.DRX
- Read New Data registers
- Read messages from Message RAM
- Reset New Data flags of processed messages

#### 38.6.5.4 Debug on CAN Support

Debug messages are stored into Rx Buffers. For debug handling three consecutive Rx buffers (e.g. #61, #62, #63) have to be used for storage of debug messages A, B, and C. The format is the same as for an Rx Buffer or an Rx FIFO element (see [38.7.2. Rx Buffer and FIFO Element](#)).

Advantage: Fixed start address for the DMA transfers (relative to RXBC.RBSA), no additional configuration required.

For filtering of debug messages Standard / Extended Filter Elements with SFEC / EFEC = "111" have to be set up. Messages matching these filter elements are stored into the Rx Buffers addressed by SFID2 / EFID2[5:0].

After message C has been stored, the DMA request output is activated and the three messages can be read from the Message RAM under DMA control. The RAM words holding the debug messages will not be changed by the CAN while DMA request is activated. The behavior is similar to that of an Rx Buffers with its New Data flag set.

After the DMA has completed the DMA unit sets the DMA acknowledge. This resets DMA request. Now the CAN is prepared to receive the next set of debug messages.

### Filtering for Debug Messages

Filtering for debug messages is done by configuring one Standard / Extended Message ID Filter Element for each of the three debug messages. To enable a filter element to filter for debug messages SFEC / EFEC has to be programmed to "111". In this case fields SFID1 / SFID2 and EFID1 / EFID2 have a different meaning (see [38.7.5. Standard Message ID Filter Element](#) and [38.7.6. Extended Message ID Filter Element](#)). While SFID2 / EFID2[10:9] controls the debug message handling state machine, SFID2 / EFID2[5:0] controls the location for storage of a received debug message.

When a debug message is stored, neither the respective New Data flag nor IR.DRX are set. The reception of debug messages can be monitored via RXF1S.DMS.

**Table 38-5.** Example Filter Configuration for Debug Messages

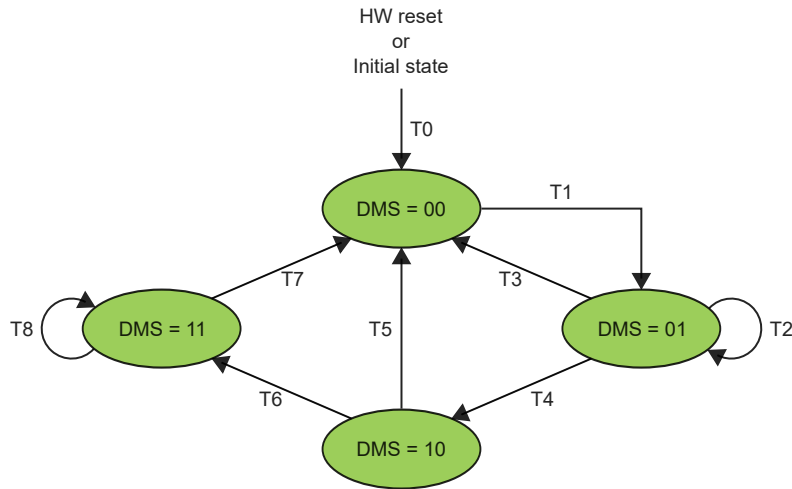
Filter Element	SFID1[10:0] / EFID1[28:0]	SFID2[10:9] / EFID2[10:9]	SFID2[5:0] / EFID2[5:0]
0	ID debug message A	01	11 1101
1	ID debug message B	10	11 1110
2	ID debug message C	11	11 1111

### Debug Message Handling

The debug message handling state machine assures that debug messages are stored to three consecutive Rx Buffers in correct order. In case of missing messages the process is restarted. The

DMA request is activated only when all three debug messages A, B, C have been received in correct order.

**Figure 38-9.** Debug Message Handling State Machine



- T0: Reset DMA request output, enable reception of debug message A, B, and C
- T1: Reception of debug message A
- T2: Reception of debug message A
- T3: Reception of debug message C
- T4: Reception of debug message B
- T5: Reception of debug message A, B
- T6: Reception of debug message C
- T7: DMA transfer completed
- T8: Reception of debug message A, B, C (message rejected)

### 38.6.6 Tx Handling

The Tx Handler handles transmission requests for the dedicated Tx Buffers, the Tx FIFO, and the Tx Queue. It controls the transfer of transmit messages to the CAN Core, the Put and Get Indices, and the Tx Event FIFO. Up to 32 Tx Buffers can be set up for message transmission. The CAN mode for transmission (Classic CAN or CAN FD) can be configured separately for each Tx Buffer element. The Tx Buffer element is described in [38.7.3. Tx Buffer Element](#). The table below describes the possible configurations for frame transmission.

**Table 38-6.** Possible Configurations for Frame Transmission

CCCR		Tx Buffer Element		Frame Transmission
BRSE	FDOE	FDF	BRS	
ignored	0	ignored	ignored	Classic CAN
0	1	0	ignored	Classic CAN
0	1	1	ignored	FD without bit rate switching
1	1	0	ignored	Classic CAN
1	1	1	0	FD without bit rate switching
1	1	1	1	FD with bit rate switching

Note: AUTOSAR requires at least three Tx Queue Buffers and support of transmit cancellation

The Tx Handler starts a Tx scan to check for the highest priority pending Tx request (Tx Buffer with lowest Message ID) when the Tx Buffer Request Pending register TXBRP is updated, or when a transmission has been started.

### 38.6.6.1 Transmit Pause

The transmit pause feature is intended for use in CAN systems where the CAN message identifiers are (permanently) specified to specific values and cannot easily be changed. These message identifiers may have a higher CAN arbitration priority than other defined messages, while in a specific application their relative arbitration priority should be inverse. This may lead to a case where one ECU sends a burst of CAN messages that cause another ECU's CAN messages to be delayed because that other messages have a lower CAN arbitration priority.

If e.g. CAN ECU-1 has the transmit pause feature enabled and is requested by its application software to transmit four messages, it will, after the first successful message transmission, wait for two CAN bit times of bus idle before it is allowed to start the next requested message. If there are other ECUs with pending messages, those messages are started in the idle time, they would not need to arbitrate with the next message of ECU-1. After having received a message, ECU-1 is allowed to start its next transmission as soon as the received message releases the CAN bus.

The transmit pause feature is controlled by bit CCCR.TXP. If the bit is set, the CAN will, each time it has successfully transmitted a message, pause for two CAN bit times before starting the next transmission. This enables other CAN nodes in the network to transmit messages even if their messages have lower prior identifiers. Default is transmit pause disabled (CCCR.TXP = '0').

This feature looses up burst transmissions coming from a single node and it protects against "babbling idiot" scenarios where the application program erroneously requests too many transmissions.

### 38.6.6.2 Dedicated Tx Buffers

Dedicated Tx Buffers are intended for message transmission under complete control of the CPU. Each Dedicated Tx Buffer is configured with a specific Message ID. In case that multiple Tx Buffers are configured with the same Message ID, the Tx Buffer with the lowest buffer number is transmitted first.

If the data section has been updated, a transmission is requested by an Add Request via TXBAR.ARn. The requested messages arbitrate internally with messages from an optional Tx FIFO or Tx Queue and externally with messages on the CAN bus, and are sent out according to their Message ID.

A Dedicated Tx Buffer allocates Element Size 32-bit words in the Message RAM (refer to table below). Therefore the start address of a dedicated Tx Buffer in the Message RAM is calculated by adding transmit buffer index (0...31) • Element Size to the Tx Buffer Start Address TXBC.TBSA.

**Table 38-7.** Tx Buffer / FIFO / Queue Element Size

TXESC.TBDS[2:0]	Data Field [bytes]	Element Size [RAM words]
000	8	4
001	12	5
010	16	6
011	20	7
100	24	8
101	32	10
110	48	14
111	64	18

### 38.6.6.3 Tx FIFO

Tx FIFO operation is configured by programming TXBC.TFQM to '0'. Messages stored in the Tx FIFO are transmitted starting with the message referenced by the Get Index TXFQS.TFGI. After each transmission the Get Index is incremented cyclically until the Tx FIFO is empty. The Tx FIFO enables transmission of messages with the same Message ID from different Tx Buffers in the order these messages have been written to the Tx FIFO. The CAN calculates the Tx FIFO Free Level TXFQS.TFFL as difference between Get and Put Index. It indicates the number of available (free) Tx FIFO elements.

New transmit messages have to be written to the Tx FIFO starting with the Tx Buffer referenced by the Put Index TXFQS.TFQPI. An Add Request increments the Put Index to the next free Tx FIFO element. When the Put Index reaches the Get Index, Tx FIFO Full (TXFQS.TFQF = '1') is signaled. In this case no further messages should be written to the Tx FIFO until the next message has been transmitted and the Get Index has been incremented.

When a single message is added to the Tx FIFO, the transmission is requested by writing a '1' to the TXBAR bit related to the Tx Buffer referenced by the Tx FIFO's Put Index.

When multiple (n) messages are added to the Tx FIFO, they are written to n consecutive Tx Buffers starting with the Put Index. The transmissions are then requested via TXBAR. The Put Index is then cyclically incremented by n. The number of requested Tx buffers should not exceed the number of free Tx Buffers as indicated by the Tx FIFO Free Level.

When a transmission request for the Tx Buffer referenced by the Get Index is canceled, the Get Index is incremented to the next Tx Buffer with pending transmission request and the Tx FIFO Free Level is recalculated. When transmission cancellation is applied to any other Tx Buffer, the Get Index and the FIFO Free Level remain unchanged.

A Tx FIFO element allocates Element Size 32-bit words in the Message RAM (refer to Table 38-7). Therefore the start address of the next available (free) Tx FIFO Buffer is calculated by adding Tx FIFO/Queue Put Index TXFQS.TFQPI (0...31) • Element Size to the Tx Buffer Start Address TXBC.TBSA.

### 38.6.6.4 Tx Queue

Tx Queue operation is configured by programming TXBC.TFQM to '1'. Messages stored in the Tx Queue are transmitted starting with the message with the lowest Message ID (highest priority). In case that multiple Queue Buffers are configured with the same Message ID, the Queue Buffer with the lowest buffer number is transmitted first.

New messages have to be written to the Tx Buffer referenced by the Put Index TXFQS.TFQPI. An Add Request cyclically increments the Put Index to the next free Tx Buffer. In case that the Tx Queue is full (TXFQS.TFQF = '1'), the Put Index is not valid and no further message should be written to the Tx Queue until at least one of the requested messages has been sent out or a pending transmission request has been canceled.

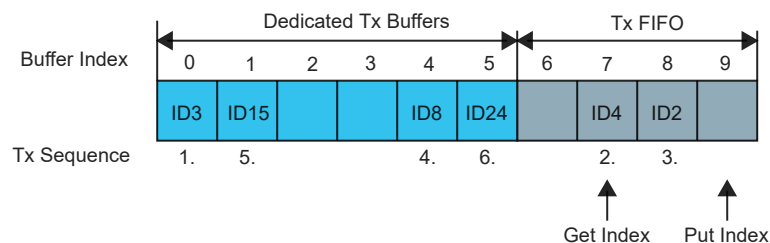
The application may use register TXBRP instead of the Put Index and may place messages to any Tx Buffer without pending transmission request.

A Tx Queue Buffer allocates Element Size 32-bit words in the Message RAM (refer to Table 38-7). Therefore the start address of the next available (free) Tx Queue Buffer is calculated by adding Tx FIFO/Queue Put Index TXFQS.TFQPI (0...31) • Element Size to the Tx Buffer Start Address TXBC.TBSA.

### 38.6.6.5 Mixed Dedicated Tx Buffers / Tx FIFO

In this case the Tx Buffers section in the Message RAM is subdivided into a set of Dedicated Tx Buffers and a Tx FIFO. The number of Dedicated Tx Buffers is configured by TXBC.NDTB. The number of Tx Buffers assigned to the Tx FIFO is configured by TXBC.TFQS. In case TXBC.TFQS is programmed to zero, only Dedicated Tx Buffers are used.

**Figure 38-10.** Example of mixed Configuration Dedicated Tx Buffers / Tx FIFO



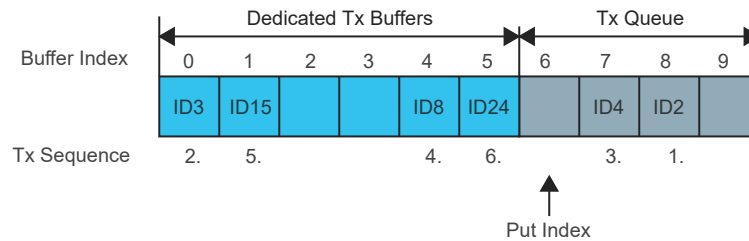
Tx prioritization:

- Scan Dedicated Tx Buffers and oldest pending Tx FIFO Buffer (referenced by TXFS.TFGI)
- Buffer with lowest Message ID gets highest priority and is transmitted next

### 38.6.6.6 Mixed Dedicated Tx Buffers / Tx Queue

In this case the Tx Buffers section in the Message RAM is subdivided into a set of Dedicated Tx Buffers and a Tx Queue. The number of Dedicated Tx Buffers is configured by TXBC.NDTB. The number of Tx Queue Buffers is configured by TXBC.TFQS. In case TXBC.TFQS is programmed to zero, only Dedicated Tx Buffers are used.

**Figure 38-11.** Example of mixed Configuration Dedicated Tx Buffers / Tx Queue



Tx prioritization:

- Scan all Tx Buffers with activated transmission request
- Tx Buffer with lowest Message ID gets highest priority and is transmitted next

### 38.6.6.7 Transmit Cancellation

The CAN supports transmit cancellation. This feature is especially intended for gateway applications and AUTOSAR based applications. To cancel a requested transmission from a dedicated Tx Buffer or a Tx Queue Buffer the CPU has to write a '1' to the corresponding bit position (=number of Tx Buffer) of register TXBCR. Transmit cancellation is not intended for Tx FIFO operation.

Successful cancellation is signaled by setting the corresponding bit of register TXBCF to '1'.

In case a transmit cancellation is requested while a transmission from a Tx Buffer is already ongoing, the corresponding TXBRP bit remains set as long as the transmission is in progress. If the transmission was successful, the corresponding TXBTO and TXBCF bits are set. If the transmission was not successful, it is not repeated and only the corresponding TXBCF bit is set.

**Note:** In case a pending transmission is canceled immediately before this transmission could have been started, there follows a short time window where no transmission is started even if another message is also pending in this node. This may enable another node to transmit a message which may have a lower priority than the second message in this node.

### 38.6.6.8 Tx Event Handling

To support Tx event handling the CAN has implemented a Tx Event FIFO. After the CAN has transmitted a message on the CAN bus, Message ID and timestamp are stored in a Tx Event FIFO element. To link a Tx event to a Tx Event FIFO element, the Message Marker from the transmitted Tx Buffer is copied into the Tx Event FIFO element.

The Tx Event FIFO can be configured to a maximum of 32 elements. The Tx Event FIFO element is described in [38.7.4. Tx Event FIFO Element](#).

When a Tx Event FIFO full condition is signaled by IR.TEFF, no further elements are written to the Tx Event FIFO until at least one element has been read out and the Tx Event FIFO Get Index has been incremented. In case a Tx event occurs while the Tx Event FIFO is full, this event is discarded and interrupt flag IR.TEFL is set.



To avoid a Tx Event FIFO overflow, the Tx Event FIFO watermark can be used. When the Tx Event FIFO fill level reaches the Tx Event FIFO watermark configured by TXEFC.EFWM, interrupt flag IR.TEFW is set.

When reading from the Tx Event FIFO, two times the Tx Event FIFO Get Index TXEFS.EFGI has to be added to the Tx Event FIFO start address TXEFC.EFSA.

### 38.6.7 FIFO Acknowledge Handling

The Get Indexes of Rx FIFO 0, Rx FIFO 1 and the Tx Event FIFO are controlled by writing to the corresponding FIFO Acknowledge Index (refer to [38.8.29. RXF0A](#), [38.8.33. RXF1A](#) and [38.8.47. TXEFA](#)). Writing to the FIFO Acknowledge Index will set the FIFO Get Index to the FIFO Acknowledge Index plus one and thereby updates the FIFO Fill Level. There are two use cases:

When only a single element has been read from the FIFO (the one being pointed to by the Get Index), this Get Index value is written to the FIFO Acknowledge Index.

When a sequence of elements has been read from the FIFO, it is sufficient to write the FIFO Acknowledge Index only once at the end of that read sequence (value: Index of the last element read), to update the FIFO's Get Index.

Due to the fact that the CPU has free access to the CAN's Message RAM, special care has to be taken when reading FIFO elements in an arbitrary order (Get Index not considered). This might be useful when reading a High Priority Message from one of the two Rx FIFOs. In this case the FIFO's Acknowledge Index should not be written because this would set the Get Index to a wrong position and also alters the FIFO's Fill Level. In this case some of the older FIFO elements would be lost.

**Note:** The application has to ensure that a valid value is written to the FIFO Acknowledge Index. The CAN does not check for erroneous values.

### 38.6.8 Interrupts

The CAN has the following interrupt sources:

- Access to Reserved Address
- Protocol Errors (Data Phase / Arbitration Phase)
- Watchdog Interrupt
- Bus\_Off Status
- Error Warning & Passive
- Error Logging Overflow
- Message RAM Bit Errors (Uncorrected / Corrected)
- Message stored to Dedicated Rx Buffer
- Timeout Occurred
- Message RAM Access Failure
- Timestamp Wraparound
- Tx Event FIFO statuses (Element Lost / Full / Watermark Reached / New Entry)
- Tx FIFO Empty
- Transmission Cancellation Finished
- Timestamp Completed
- High Priority Message
- Rx FIFO 1 Statuses (Message Lost / Full / Watermark Reached / New Message)
- Rx FIFO 0 Statuses (Message Lost / Full / Watermark Reached / New Message)

Each interrupt source has an interrupt flag associated with it. The interrupt flag register (IR) is set when the interrupt condition occurs. Each interrupt can be individually enabled by writing '1' or disabled by writing '0' to the corresponding bit in the interrupt enable register (IE). Each interrupt flag can be assigned to one of two interrupt service lines.

An interrupt request is generated when an interrupt flag is set, the corresponding interrupt enable is set, and the corresponding service line enable assigned to the interrupt is set. The interrupt request remains active until the interrupt flag is cleared, the interrupt is disabled, the service line is disabled, or the CAN is reset. Refer to [38.8.16. IR](#) for details on how to clear interrupt flags. All interrupt requests from the peripheral are sent to the [NVIC](#). The user must read the IR register to determine which interrupt condition is present.

Note that interrupts must be globally enabled for interrupt requests to be generated.

### 38.6.9 Sleep Mode Operation

The CAN can operate in IDLE0 sleep mode, but cannot operate in IDLE2 and Standby sleep modes.

The CAN has its own low-power mode that may be used at any time without disabling the CAN. It is also mandatory to allow the CAN to complete all pending transactions before entering stand-by by activating this Low-Power mode. This is performed by writing one to the Clock Stop Request bit in the CC Control register (CCCR.CSR = 1). Once all pending transactions are completed and the idle bus state is detected, the CAN will automatically set the Clock Stop Acknowledge bit (CCCR.CSA = 1). The CAN then reverts to its initial state (CCCR.INIT = 1), blocking further transfers, and it is now safe for CLK\_CANx\_APB and GCLK\_CANx to be switched off and the system may go to standby.

To leave Low-Power mode, CLK\_CANx\_APB and GCLK\_CANx must be active before writing CCCR.CSR to '0'. The CAN will acknowledge this by resetting CCCR.CSA = 0. Afterwards, the application can restart CAN communication by resetting the CCCR.INIT bit.

### 38.6.10 Synchronization

Due to the asynchronicity between the main clock domain (CLK\_CAN\_APB) and the peripheral clock domain (GCLK\_CAN) some registers are synchronized when written. When a write-synchronized register is written, the read back value will not be updated until the register has completed synchronization.

The following bits and registers are write-synchronized:

- INIT Initialization bit in CC Control register (CCCR.INIT)

## 38.7 Message RAM

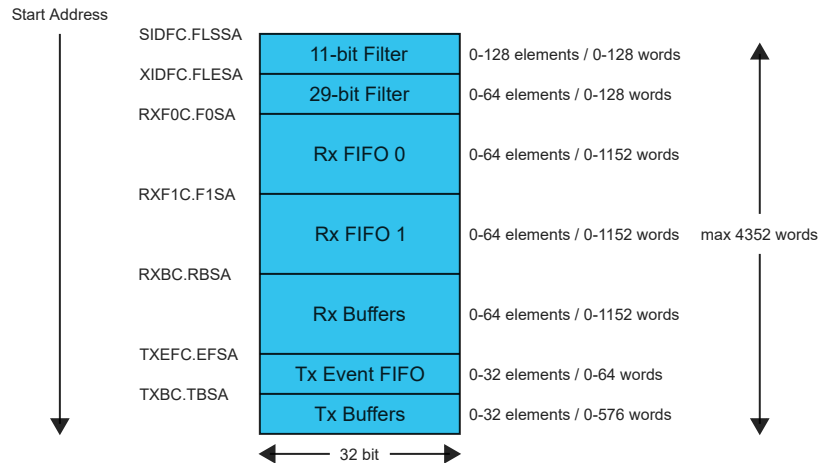
For storage of Rx/Tx messages and for storage of the filter configuration a single- or dual-ported Message RAM has to be connected to the CAN module.

### 38.7.1 Message RAM Configuration

The Message RAM has a width of 32 bits. In case parity checking or ECC is used a respective number of bits has to be added to each word. The CAN module can be configured to allocate up to 4352 words in the Message RAM. It is not necessary to configure each of the sections listed in the figure below, nor is there any restriction with respect to the sequence of the sections.

When operated in CAN FD mode the required Message RAM size strongly depends on the element size configured for Rx FIFO 0, Rx FIFO 1, Rx Buffers, and Tx Buffers via RXESC.F0DS, RXESC.F1DS, RXESC.RBDS, and TXESC.TBDS.

Figure 38-12. Message RAM Configuration



When the CAN addresses the Message RAM it addresses 32-bit words, not single bytes. The configurable start addresses are 32-bit word addresses (i.e., only bits 15 to 2 are evaluated and the two LSBs are ignored).

**Note:** Message RAM can only be located in the first 64 KB area of the system RAM.



The CAN does not check for erroneous configuration of the Message RAM. Especially the configuration of the start addresses of the different sections and the number of elements of each section has to be done carefully to avoid falsification or loss of data.

### 38.7.2 Rx Buffer and FIFO Element

Up to 64 Rx Buffers and two Rx FIFOs can be configured in the Message RAM. Each Rx FIFO section can be configured to store up to 64 received messages. The structure of a Rx Buffer / FIFO element is shown in the table below. The element size can be configured for storage of CAN FD messages with up to 64 bytes data field via register RXESC.

Table 38-8. Rx Buffer and FIFO Element

	31	30	29	28	27	26	25	24	23	22	21	20	19	18	17	16	15	14	13	12	11	10	9	8	7	6	5	4	3	2	1	0
R0	E S I	X T D	R T T R	ID[28:0]																												
R1	A N M F	FID[6:0]								F D F	B R S	DLC[3:0]			RXTS[15:0]																	
R2	DB3[7:0]						DB2[7:0]						DB1[7:0]						DB0[7:0]													
R3	DB7[7:0]						DB6[7:0]						DB5[7:0]						DB4[7:0]													
...	...						...						...						...													
Rn	DBm[7:0]						DBm-1[7:0]						DBm-2[7:0]						DBm-3[7:0]													

- R0 Bit 31 - ESI: Error State Indicator  
0 : Transmitting node is error active.  
1 : Transmitting node is error passive.
- R0 Bit 30 - XTD: Extended Identifier

Signals to the Host whether the received frame has a standard or extended identifier.

0 : 11-bit standard identifier.

1 : 29-bit extended identifier.

- R0 Bit 29 - RTR: Remote Transmission Request

Signals to the Host whether the received frame is a data frame or a remote frame.

0 : Received frame is a data frame.

1 : Received frame is a remote frame.

**Note:** There are no remote frames in CAN FD format. In case a CAN FD frame was received (EDL = '1'), bit RTR reflects the state of the reserved bit r1.

- R0 Bits 28:0 - ID[28:0]: Identifier

Standard or extended identifier depending on bit XTD. A standard identifier is stored into ID[28:18].

- R1 Bit 31 - ANMF: Accepted Non-matching Frame

Acceptance of non-matching frames may be enabled via GFC.ANFS and GFC.ANFE.

0 : Received frame matching filter index FIDX.

1 : Received frame did not match any Rx filter element.

- R1 Bits 30:24 - FIDX[6:0]: Filter Index

0-127 : Index of matching Rx acceptance filter element (invalid if ANMF = '1').

**Note:** Range is 0 to SIDFC.LSS-1 for standard and 0 to XIDFC.LSE-1 for extended.

- R1 Bits 23:22 - Reserved

- R1 Bit 21 - FDF: FD Format

0 : Standard frame format.

1 : CAN FD frame format (new DLC-coding and CRC).

- R1 Bit 20 - BRS: Bit Rate Search

0 : Frame received without bit rate switching.

1 : Frame received with bit rate switching.

- R1 Bits 19:16 - DLC[3:0]: Data Length Code

0-8 : CAN + CAN FD: received frame has 0-8 data bytes.

9-15 : CAN: received frame has 8 data bytes.

9-15 : CAN FD: received frame has 12/16/20/24/32/48/64 data bytes.

- R1 Bits 15:0 - RXTS[15:0]: Rx Timestamp

Timestamp Counter value captured on start of frame reception. Resolution depending on configuration of the Timestamp Counter Prescaler TSCC.TCP.

- R2 Bits 31:24 - DB3[7:0]: Data Byte 3

- R2 Bits 23:16 - DB2[7:0]: Data Byte 2

- R2 Bits 15:8 - DB1[7:0]: Data Byte 1

- R2 Bits 7:0 - DB0[7:0]: Data Byte 0

- R3 Bits 31:24 - DB7[7:0]: Data Byte 7

- R3 Bits 23:16 - DB6[7:0]: Data Byte 6

- R3 Bits 15:8 - DB5[7:0]: Data Byte 5

- R3 Bits 7:0 - DB4[7:0]: Data Byte 4

...

- Rn Bits 31:24 - DBm[7:0]: Data Byte m
- Rn Bits 23:16 - DBm-1[7:0]: Data Byte m-1
- Rn Bits 15:8 - DBm-2[7:0]: Data Byte m-2
- Rn Bits 7:0 - DBm-3[7:0]: Data Byte m-3



Depending on the configuration of RXESC, between two and sixteen 32-bit words (Rn = 3 ... 17) are used for storage of a CAN message's data field.

### 38.7.3 Tx Buffer Element

The Tx Buffers section can be configured to hold dedicated Tx Buffers as well as a Tx FIFO / Tx Queue. In case that the Tx Buffers section is shared by dedicated Tx buffers and a Tx FIFO / Tx Queue, the dedicated Tx Buffers start at the beginning of the Tx Buffers section followed by the buffers assigned to the Tx FIFO or Tx Queue. The Tx Handler distinguishes between dedicated Tx Buffers and Tx FIFO / Tx Queue by evaluating the Tx Buffer configuration TXBC.TFQS and TXBC.NDTB. The element size can be configured for storage of CAN FD messages with up to 64 bytes data field via register TXESC.

**Table 38-9.** Tx Buffer Element

	31	30	29	28	27	26	25	24	23	22	21	20	19	18	17	16	15	14	13	12	11	10	9	8	7	6	5	4	3	2	1	0
T0	ESI	XTD	RTR	ID[28:0]																												
T1	MM[7:0]								EC	FD	FB	DR	DLC[3:0]																			
T2	DB3[7:0]								DB2[7:0]				DB1[7:0]				DB0[7:0]															
T3	DB7[7:0]								DB6[7:0]				DB5[7:0]				DB4[7:0]															
...	...								...				...				...															
Tn	DBm[7:0]								DBm-1[7:0]				DBm-2[7:0]				DBm-3[7:0]															

- T0 Bit 31 - ESI: Error State Indicator  
0 : ESI bit in CAN FD format depends only on error passive flag.  
1 : ESI bit in CAN FD format transmitted recessive.  
**Note:** The ESI bit of the transmit buffer is OR'ed with the error passive flag to decide the value of the ESI bit in the transmitted FD frame. As required by the CAN FD protocol specification, an error active node may optionally transmit the ESI bit recessive, but an error passive node will always transmit the ESI bit recessive.
- T0 Bit 30 - XTD: Extended Identifier  
0 : 11-bit standard identifier.  
1 : 29-bit extended identifier.
- T0 Bit 29 - RTR: Remote Transmission Request  
0 : Transmit data frame.  
1 : Transmit remote frame.  
**Note:** When RTR = '1', the CAN transmits a remote frame according to ISO 11898-1, even if CCCR.CME enables the transmission in CAN FD format.
- T0 Bits 28:0 - ID[28:0]: Identifier  
Standard or extended identifier depending on bit XTD. A standard identifier is stored into ID[28:18].

- T1 Bits 31:24 - MM[7:0]: Message Marker  
Written by CPU during Tx Buffer configuration. Copied into Tx Event FIFO element for identification of Tx message status.
- T1 Bit 23 - EFC: Event FIFO Control  
0 : Don't store Tx events.  
1 : Store Tx events.
- T1 Bit 22 - Reserved
- TR1 Bit 21 - FDF: FD Format  
0 : Frame transmitted in Classic CAN format.  
1 : Frame transmitted in CAN FD format.
- T1 Bit 20 - BRS: Bit Rate Search  
0 : CAN FD frames transmitted without bit rate switching.  
1 : CAN FD frames transmitted with bit rate switching.  
**Note:** Bits ESI, FDF, and BRS are only evaluated when CAN FD operation is enabled CCCR.FDOE = '1'. Bit BRS is only evaluated when in addition CCCR.BRSE = '1'.
- T1 Bits 19:16 - DLC[3:0]: Data Length Code  
0-8 : CAN + CAN FD: received frame has 0-8 data bytes.  
9-15 : CAN: received frame has 8 data bytes.  
9-15 : CAN FD: received frame has 12/16/20/24/32/48/64 data bytes.
- T1 Bits 15:0 - Reserved
- T2 Bits 31:24 - DB3[7:0]: Data Byte 3
- T2 Bits 23:16 - DB2[7:0]: Data Byte 2
- T2 Bits 15:8 - DB1[7:0]: Data Byte 1
- T2 Bits 7:0 - DB0[7:0]: Data Byte 0
- T3 Bits 31:24 - DB7[7:0]: Data Byte 7
- T3 Bits 23:16 - DB6[7:0]: Data Byte 6
- T3 Bits 15:8 - DB5[7:0]: Data Byte 5
- T3 Bits 7:0 - DB4[7:0]: Data Byte 4
- ...
- Tn Bits 31:24 - DBm[7:0]: Data Byte m
- Tn Bits 23:16 - DBm-1[7:0]: Data Byte m-1
- Tn Bits 15:8 - DBm-2[7:0]: Data Byte m-2
- Tn Bits 7:0 - DBm-3[7:0]: Data Byte m-3

**Note:** Depending on the configuration of TXESC, between two and sixteen 32-bit words (Tn = 3 ... 17) are used for storage of a CAN message's data field.

#### 38.7.4 Tx Event FIFO Element

Each element stores information about transmitted messages. By reading the Tx Event FIFO the Host CPU gets this information in the order the messages were transmitted. Status information about the Tx Event FIFO can be obtained from register TXEFS.

**Table 38-10. Tx Event FIFO Element**

	31	30	29	28	27	26	25	24	23	22	21	20	19	18	17	16	15	14	13	12	11	10	9	8	7	6	5	4	3	2	1	0
E0	ESI	XTD	RTR	ID[28:0]																												
E1	MM[7:0]							ET[1:0]		FDFS		BRS		DLC[3:0]			TXTS[15:0]															

- E0 Bit 31 - ESI: Error State Indicator  
0 : Transmitting node is error active.  
1 : Transmitting node is error passive.
- E0 Bit 30 - XTD: Extended Identifier  
0 : 11-bit standard identifier.  
1 : 29-bit extended identifier.
- E0 Bit 29 - RTR: Remote Transmission Request  
0 : Received frame is a data frame.  
1 : Received frame is a remote frame.
- E0 Bits 28:0 - ID[28:0]: Identifier  
Standard or extended identifier depending on bit XTD. A standard identifier is stored into ID[28:18].
- E1 Bits 31:24 - MM[7:0]: Message Marker  
Copied from Tx Buffer into Tx Event FIFO element for identification of Tx message status.
- E1 Bits 23:22 - ET[1:0]: Event Type  
This field defines the event type.

**Table 38-11. Event Type**

Value	Name	Description
0x0 or 0x3	RES	Reserved
0x1	TXE	Tx event
0x2	TXC	Transmission in spite of cancellation (always set for transmission in DAR mode)

- E1 Bit 21 - FDF: FD Format  
0 : Standard frame format.  
1 : CAN FD frame format (new DLC-coding and CRC).
- E1 Bit 20 - BRS: Bit Rate Search  
0 : Frame received without bit rate switching.  
1 : Frame received with bit rate switching.
- E1 Bits 19:16 - DLC[3:0]: Data Length Code  
0-8 : CAN + CAN FD: received frame has 0-8 data bytes.  
9-15 : CAN: received frame has 8 data bytes.  
9-15 : CAN FD: received frame has 12/16/20/24/32/48/64 data bytes.
- E1 Bits 15:0 - TXTS[15:0]: Tx Timestamp  
Timestamp Counter value captured on start of frame transmission. Resolution depending on configuration of the Timestamp Counter Prescaler TSCC.TCP.

### 38.7.5 Standard Message ID Filter Element

Up to 128 filter elements can be configured for 11-bit standard IDs. When accessing a Standard Message ID Filter element, its address is the Filter List Standard Start Address SIDFC.FLSSA plus the index of the filter element (0 ... 127).

**Table 38-12.** Standard Message ID Filter Element

	31	30	29	28	27	26	25	24	23	22	21	20	19	18	17	16	15	14	13	12	11	10	9	8	7	6	5	4	3	2	1	0
S0	SFT [1:0]		SFEC [2:0]		SFID1[10:0]										SFID2[10:0]																	

- Bits 31:30 - SFT[1:0]: Standard Filter Type  
This field defines the standard filter type.

**Table 38-13.** Standard Filter Type

Value	Name	Description
0x0	RANGE	Range filter from SFID1 to SFID2 (SFID2 >= SFID1)
0x1	DUAL	Dual ID filter for SFID1 or SFID2
0x2	CLASSIC	Classic filter: SFID1 = filter, SFID2 = mask
0x3	RES	Reserved

- Bits 29:27 - SFEC[2:0]: Standard Filter Element Configuration  
All enabled filter elements are used for acceptance filtering of standard frames. Acceptance filtering stops at the first matching enabled filter element or when the end of the filter list is reached. If SFEC = "100", "101", or "110" a match sets interrupt flag IR.HPM and, if enabled, an interrupt is generated. In this case register HPMS is updated with the status of the priority match.

**Table 38-14.** Standard Filter Element Configuration

Value	Name	Description
0x0	DISABLE	Disable filter element
0x1	STF0M	Store in Rx FIFO 0 if filter matches
0x2	STF1M	Store in Rx FIFO 1 if filter matches
0x3	REJECT	Reject ID if filter matches
0x4	PRIORITY	Set priority if filter matches.
0x5	PRIF0M	Set priority and store in FIFO 0 if filter matches.
0x6	PRIF1M	Set priority and store in FIFO 1 if filter matches.
0x7	STRXBUF	Store into Rx Buffer or as debug message, configuration of SFT[1:0] ignored.

- Bits 26:16 - SFID1[10:0]: Standard Filter ID 1  
First ID of standard ID filter element.  
When filtering for Rx Buffers or for debug messages this field defines the ID of a standard message to be stored. The received identifiers must match exactly, no masking mechanism is used.
- Bits 15:11 - Reserved
- Bits 10:0 - SFID2[10:0]: Standard Filter ID 2  
This bit field has a different meaning depending on the configuration of SFEC.
  - SFEC = "001" ... "110": Second ID of standard ID filter element.
  - SFEC = "111": Filter for Rx Buffers or for debug messages.
 SFID2[10:9] decides whether the received message is stored into an Rx Buffer or treated as message A, B, or C of the debug message sequence.  
00 = Store message into an Rx Buffer



01 = Debug Message A  
10 = Debug Message B  
11 = Debug Message C  
SFID2[8:6] is Reserved.

SFID2[5:0] defines the offset to the Rx Buffer Start Address RXBC.RBSA for storage of a matching message.

### 38.7.6 Extended Message ID Filter Element

Up to 64 filter elements can be configured for 29-bit extended IDs. When accessing an Extended Message ID Filter element, its address is the Filter List Extended Start Address XIDFC.FLESA plus two times the index of the filter element (0...63).

**Table 38-15.** Extended Message ID Filter Element

	31	30	29	28	27	26	25	24	23	22	21	20	19	18	17	16	15	14	13	12	11	10	9	8	7	6	5	4	3	2	1	0
F0	EFEC [2:0]		EFID1[28:0]																													
F1	EFT [1:0]		EFID2[28:0]																													

- F0 Bits 31:29 - EFEC[2:0]: Extended Filter Element Configuration  
All enabled filter elements are used for acceptance filtering of extended frames. Acceptance filtering stops at the first matching enabled filter element or when the end of the filter list is reached. If EFEC = "100", "101", or "110" a match sets interrupt flag IR.HPM and, if enabled, an interrupt is generated. In this case register HPMS is updated with the status of the priority match.

**Table 38-16.** Extended Filter Element Configuration

Value	Name	Description
0x0	DISABLE	Disable filter element.
0x1	STF0M	Store in Rx FIFO 0 if filter matches.
0x2	STF1M	Store in Rx FIFO 1 if filter matches.
0x3	REJECT	Reject ID if filter matches.
0x4	PRIORITY	Set priority if filter matches.
0x5	PRIF0M	Set priority and store in FIFO 0 if filter matches.
0x6	PRIF1M	Set priority and store in FIFO 1 if filter matches.
0x7	STRXBUF	Store into Rx Buffer or as debug message, configuration of EFT[1:0] ignored.

- F0 Bits 28:0 - EFID1[28:0]: Extended Filter ID 1  
First ID of extended ID filter element.  
When filtering for Rx Buffers or for debug messages this field defines the ID of a extended message to be stored. The received identifiers must match exactly, only XIDAM masking mechanism is used.
- F1 Bits 31:30 - EFT[1:0]: Extended Filter Type  
This field defines the extended filter type.

**Table 38-17.** Extended Filter Type

Value	Name	Description
0x0	RANGEM	Range filter from EFID1 to EFID2 (EFID2 >= EFID1).
0x1	DUAL	Dual ID filter for EFID1 or EFID2.
0x2	CLASSIC	Classic filter: EFID1 = filter, EFID2 = mask.
0x3	RANGE	Range filter from EFID1 to EFID2 (EFID2 >= EFID1), XIDAM mask not applied.

- F1 Bits 28:0 - EFID2[28:0]: Extended Filter ID 2

This bit field has a different meaning depending on the configuration of EFEC.

- 1) EFEC = "001" ... "110" Second ID of standard ID filter element.
- 2) EFEC = "111" Filter for Rx Buffers or for debug messages.

EFID2[10:9] decides whether the received message is stored into an Rx Buffer or treated as message A, B, or C of the debug message sequence.

00 = Store message into an Rx Buffer

01 = Debug Message A

10 = Debug Message B

11 = Debug Message C

EFID2[8:6] is used to control the filter event pins at the Extension Interface. A '1' at the respective bit position enables generation of a pulse at the related filter event pin with the duration of one CLK\_CAN\_APB period in case the filter matches.

EFID2[5:0] defines the offset to the Rx Buffer Start Address RXBC.RBSA for storage of a matching message.

## 38.8 Register Summary

Offset	Name	Bit Pos.	7	6	5	4	3	2	1	0	
0x00	CREL	7:0									
		15:8									
		23:16	SUBSTEP[3:0]								
		31:24	REL[3:0]			STEP[3:0]					
0x04	ENDN	7:0				ETV[7:0]					
		15:8				ETV[15:8]					
		23:16				ETV[23:16]					
		31:24				ETV[31:24]					
0x08	MRCFG	7:0							QOS[1:0]		
		15:8									
		23:16									
		31:24									
0x0C	DBTP	7:0	DTSEG2[3:0]				DSJW[3:0]				
		15:8				DTSEG1[4:0]					
		23:16	TDC			DBRP[4:0]					
		31:24									
0x10	TEST	7:0	RX	TX[1:0]		LBCK					
		15:8									
		23:16									
		31:24									
0x14	RWD	7:0	WDC[7:0]								
		15:8	WDV[7:0]								
		23:16									
		31:24									
0x18	CCCR	7:0	TEST	DAR	MON	CSR	CSA	ASM	CCE	INIT	
		15:8		TXP	EFBI	PXHD			BRSE	FDOE	
		23:16									
		31:24									
0x1C	NBTP	7:0	NTSEG2[6:0]								
		15:8	NTSEG1[7:0]								
		23:16	NBRP[7:0]								
		31:24	NSJW[6:0]			NBRP[8]					
0x20	TSCC	7:0							TSS[1:0]		
		15:8									
		23:16	TCP[3:0]								
		31:24									
0x24	TSCV	7:0	TSC[7:0]								
		15:8	TSC[15:8]								
		23:16									
		31:24									
0x28	TOCC	7:0						TOS[1:0]		ETOC	
		15:8									
		23:16	TOP[7:0]								
		31:24	TOP[15:8]								
0x2C	TOCV	7:0	TOC[7:0]								
		15:8	TOC[15:8]								
		23:16									
		31:24									
0x30 ... 0x3F	Reserved										
0x40	ECR	7:0	TEC[7:0]								
		15:8	RP	REC[6:0]							
		23:16	CEL[7:0]								
		31:24									
0x44	PSR	7:0	BO	EW	EP	ACT[1:0]		LEC[2:0]			
		15:8		PXE	RFDF	RBRS	RESI	DLEC[2:0]			
		23:16	TDCV[6:0]								
		31:24									

.....continued

Offset	Name	Bit Pos.	7	6	5	4	3	2	1	0	
0x48	TDCR	7:0					TDCF[6:0]				
		15:8					TDCO[6:0]				
		23:16									
		31:24									
0x4C ... 0x4F	Reserved										
0x50	IR	7:0	RF1L	RF1F	RF1W	RF1N	RF0L	RF0F	RF0W	RF0N	
		15:8	TEFL	TEFF	TEFW	TEFN	TFE	TCF	TC	HPM	
		23:16	EP	ELO	BEU	BEC	DRX	TOO	MRAF	TSW	
		31:24			ARA	PED	PEA	WDI	BO	EW	
0x54	IE	7:0	RF1LE	RF1FE	RF1WE	RF1NE	RF0LE	RF0FE	RF0WE	RF0NE	
		15:8	TEFLE	TEFFE	TEFWE	TEFNE	TFEE	TCFE	TCE	HPME	
		23:16	EPE	ELOE	BEUE	BECE	DRXE	TOOE	MRAFE	TSWE	
		31:24			ARAE	PEDE	PEAE	WDIE	BOE	EWE	
0x58	ILS	7:0	RF1LL	RF1FL	RF1WL	RF1NL	RF0LL	RF0FL	RF0WL	RF0NL	
		15:8	TEFLL	TEFFL	TEFWL	TEFNL	TFEL	TCFL	TCL	HPML	
		23:16	EPL	ELOL	BEUL	BECL	DRXL	TOOL	MRAFL	TSWL	
		31:24			ARAL	PEDL	PEAL	WDIL	BOL	EWL	
0x5C	ILE	7:0							EINT1	EINT0	
		15:8									
		23:16									
		31:24									
0x60 ... 0x7F	Reserved										
0x80	GFC	7:0			ANFS[1:0]		ANFE[1:0]		RRFS	RRFE	
		15:8									
		23:16									
		31:24									
0x84	SIDFC	7:0	FLSSA[7:0]								
		15:8	FLSSA[15:8]								
		23:16	LSS[7:0]								
		31:24									
0x88	XIDFC	7:0	FLESA[7:0]								
		15:8	FLESA[15:8]								
		23:16	LSE[6:0]								
		31:24									
0x8C ... 0x8F	Reserved										
0x90	XIDAM	7:0	EIDM[7:0]								
		15:8	EIDM[15:8]								
		23:16	EIDM[23:16]								
		31:24	EIDM[28:24]								
0x94	HPMS	7:0	MSI[1:0]		BIDX[5:0]						
		15:8	FLST	FIDX[6:0]							
		23:16									
		31:24									
0x98	NDAT1	7:0	ND7	ND6	ND5	ND4	ND3	ND2	ND1	ND0	
		15:8	ND15	ND14	ND13	ND12	ND11	ND10	ND9	ND8	
		23:16	ND23	ND22	ND21	ND20	ND19	ND18	ND17	ND16	
		31:24	ND31	ND30	ND29	ND28	ND27	ND26	ND25	ND24	
0x9C	NDAT2	7:0	ND39	ND38	ND37	ND36	ND35	ND34	ND33	ND32	
		15:8	ND47	ND46	ND45	ND44	ND43	ND42	ND41	ND40	
		23:16	ND55	ND54	ND53	ND52	ND51	ND50	ND49	ND48	
		31:24	ND63	ND62	ND61	ND60	ND59	ND58	ND57	ND56	
0xA0	RXFOC	7:0	FOSA[7:0]								
		15:8	FOSA[15:8]								
		23:16		FOS[6:0]							
		31:24	F00M	FOWM[6:0]							

.....continued

Offset	Name	Bit Pos.	7	6	5	4	3	2	1	0	
0xA4	RXF0S	7:0	F0FL[6:0]								
		15:8	F0GI[5:0]								
		23:16	F0PI[5:0]								
		31:24								RFOL	F0F
0xA8	RXF0A	7:0	F0AI[5:0]								
		15:8									
		23:16									
		31:24									
0xAC	RXBC	7:0	RBSA[7:0]								
		15:8	RBSA[15:8]								
		23:16									
		31:24									
0xB0	RXF1C	7:0	F1SA[7:0]								
		15:8	F1SA[15:8]								
		23:16	F1S[6:0]								
		31:24	F1OM								F1WM[6:0]
0xB4	RXF1S	7:0	F1FL[6:0]								
		15:8	F1GI[5:0]								
		23:16	F1PI[5:0]								
		31:24	DMS[1:0]								RF1L
0xB8	RXF1A	7:0	F1AI[5:0]								
		15:8									
		23:16									
		31:24									
0xBC	RXESC	7:0	F1DS[2:0]							F0DS[2:0]	
		15:8								RBDS[2:0]	
		23:16									
		31:24									
0xC0	TXBC	7:0	TBSA[7:0]								
		15:8	TBSA[15:8]								
		23:16	NDTB[5:0]								
		31:24	TFQM								TFQS[5:0]
0xC4	TXFQS	7:0	TFFL[5:0]								
		15:8	TFGI[4:0]								
		23:16	TFQF								TFQPI[4:0]
		31:24									
0xC8	TXESC	7:0	TBDS[2:0]								
		15:8									
		23:16									
		31:24									
0xCC	TXBRP	7:0	TRP7	TRP6	TRP5	TRP4	TRP3	TRP2	TRP1	TRP0	
		15:8	TRP15	TRP14	TRP13	TRP12	TRP11	TRP10	TRP9	TRP8	
		23:16	TRP23	TRP22	TRP21	TRP20	TRP19	TRP18	TRP17	TRP16	
		31:24	TRP31	TRP30	TRP29	TRP28	TRP27	TRP26	TRP25	TRP24	
0xD0	TXBAR	7:0	AR7	AR6	AR5	AR4	AR3	AR2	AR1	AR0	
		15:8	AR15	AR14	AR13	AR12	AR11	AR10	AR9	AR8	
		23:16	AR23	AR22	AR21	AR20	AR19	AR18	AR17	AR16	
		31:24	AR31	AR30	AR29	AR28	AR27	AR26	AR25	AR24	
0xD4	TXBCR	7:0	CR7	CR6	CR5	CR4	CR3	CR2	CR1	CR0	
		15:8	CR15	CR14	CR13	CR12	CR11	CR10	CR9	CR8	
		23:16	CR23	CR22	CR21	CR20	CR19	CR18	CR17	CR16	
		31:24	CR31	CR30	CR29	CR28	CR27	CR26	CR25	CR24	
0xD8	TXBTO	7:0	TO7	TO6	TO5	TO4	TO3	TO2	TO1	TO0	
		15:8	TO15	TO14	TO13	TO12	TO11	TO10	TO9	TO8	
		23:16	TO23	TO22	TO21	TO20	TO19	TO18	TO17	TO16	
		31:24	TO31	TO30	TO29	TO28	TO27	TO26	TO25	TO24	
0xDC	TXBCF	7:0	CF7	CF6	CF5	CF4	CF3	CF2	CF1	CF0	
		15:8	CF15	CF14	CF13	CF12	CF11	CF10	CF9	CF8	
		23:16	CF23	CF22	CF21	CF20	CF19	CF18	CF17	CF16	
		31:24	CF31	CF30	CF29	CF28	CF27	CF26	CF25	CF24	

.....continued

Offset	Name	Bit Pos.	7	6	5	4	3	2	1	0	
0xE0	TXBTIE	7:0	TIE7	TIE6	TIE5	TIE4	TIE3	TIE2	TIE1	TIE0	
		15:8	TIE15	TIE14	TIE13	TIE12	TIE11	TIE10	TIE9	TIE8	
		23:16	TIE23	TIE22	TIE21	TIE20	TIE19	TIE18	TIE17	TIE16	
		31:24	TIE31	TIE30	TIE29	TIE28	TIE27	TIE26	TIE25	TIE24	
0xE4	TXBCIE	7:0	CFIE7	CFIE6	CFIE5	CFIE4	CFIE3	CFIE2	CFIE1	CFIE0	
		15:8	CFIE15	CFIE14	CFIE13	CFIE12	CFIE11	CFIE10	CFIE9	CFIE8	
		23:16	CFIE23	CFIE22	CFIE21	CFIE20	CFIE19	CFIE18	CFIE17	CFIE16	
		31:24	CFIE31	CFIE30	CFIE29	CFIE28	CFIE27	CFIE26	CFIE25	CFIE24	
0xE8 ... 0xEF	Reserved										
0xF0	TXEFC	7:0	EFSA[7:0]								
		15:8	EFSA[15:8]								
		23:16								EFS[5:0]	
		31:24								EFWM[5:0]	
0xF4	TXEFS	7:0								EFFL[5:0]	
		15:8								EFGI[4:0]	
		23:16								EFPI[4:0]	
		31:24									TEFL
0xF8	TXEFA	7:0								EFAI[4:0]	
		15:8									
		23:16									
		31:24									

### 38.8.1 Core Release

**Name:** CREL  
**Offset:** 0x00  
**Reset:** 0x32100000  
**Property:** Read-only

Bit	31	30	29	28	27	26	25	24
	REL[3:0]				STEP[3:0]			
Access	R	R	R	R	R	R	R	R
Reset	0	0	1	1	0	0	1	0
Bit	23	22	21	20	19	18	17	16
	SUBSTEP[3:0]							
Access	R	R	R	R				
Reset	0	0	0	1				
Bit	15	14	13	12	11	10	9	8
Access								
Reset								
Bit	7	6	5	4	3	2	1	0
Access								
Reset								

**Bits 31:28 – REL[3:0]** Core Release  
One digit, BCD-coded.

**Bits 27:24 – STEP[3:0]** Step of Core Release  
One digit, BCD-coded.

**Bits 23:20 – SUBSTEP[3:0]** Sub-step of Core Release  
One digit, BCD-coded.

### 38.8.2 Endian

**Name:** ENDN  
**Offset:** 0x04  
**Reset:** 0x87654321  
**Property:** Read-only

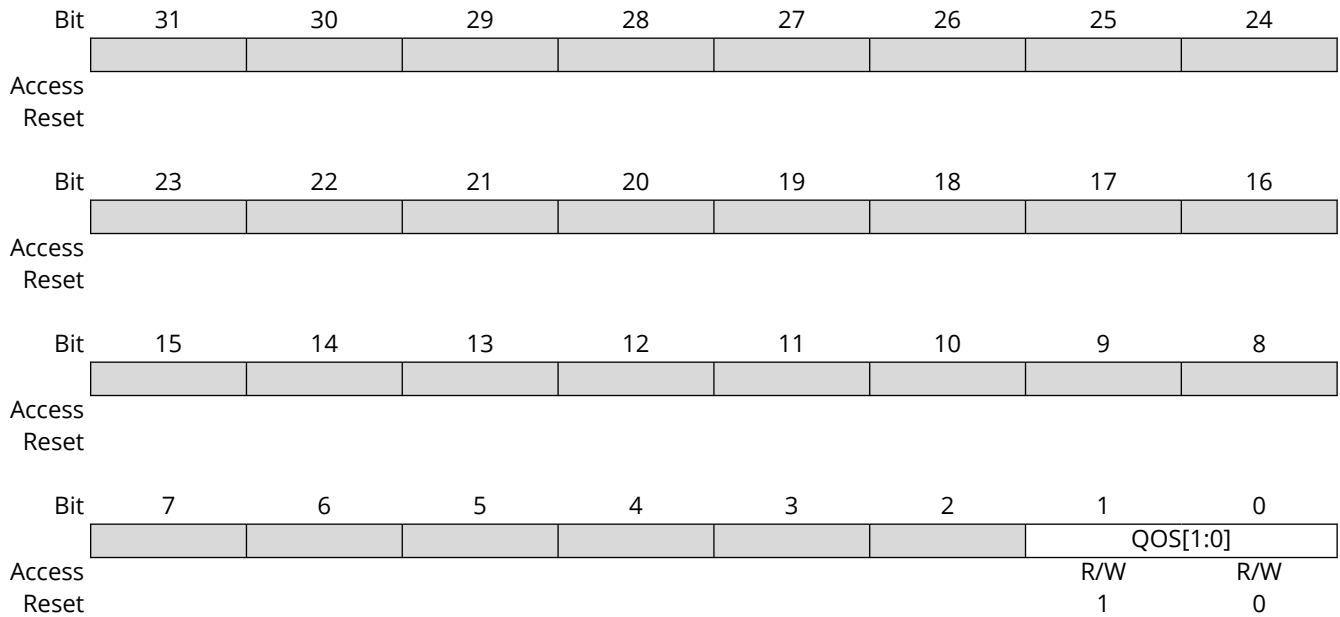
Bit	31	30	29	28	27	26	25	24
ETV[31:24]								
Access	R	R	R	R	R	R	R	R
Reset	1	0	0	0	0	1	1	1
Bit	23	22	21	20	19	18	17	16
ETV[23:16]								
Access	R	R	R	R	R	R	R	R
Reset	0	1	1	0	0	1	0	1
Bit	15	14	13	12	11	10	9	8
ETV[15:8]								
Access	R	R	R	R	R	R	R	R
Reset	0	1	0	0	0	0	1	1
Bit	7	6	5	4	3	2	1	0
ETV[7:0]								
Access	R	R	R	R	R	R	R	R
Reset	0	0	1	0	0	0	0	1

**Bits 31:0 – ETV[31:0]** Endianness Test Value  
The endianness test value is 0x87654321



### 38.8.3 Message RAM Configuration

**Name:** MRCFG  
**Offset:** 0x08  
**Reset:** 0x00000002  
**Property:** -



#### Bits 1:0 – QOS[1:0] Data Quality of Service

This field defines the memory priority access during the Message RAM read/write data operation.

Value	Name	Description
0x0	DISABLE	Background (no sensitive operation)
0x1	LOW	Sensitive bandwidth
0x2	MEDIUM	Sensitive latency
0x3	HIGH	Critical latency

### 38.8.4 Data Bit Timing and Prescaler

**Name:** DBTP  
**Offset:** 0x0C  
**Reset:** 0x00000A33  
**Property:** Write-restricted

This register is write-restricted and only writable if bit fields CCCR.CCE = 1 and CCCR.INIT = 1.

The CAN bit time may be programmed in the range of 4 to 49 time quanta. The CAN time quantum may be programmed in the range of 1 to 32 GCLK\_CAN periods.  $t_q = (DBRP + 1) mtq$ .

**Note:**

With a GCLK\_CAN of 8MHz, the reset value 0x00000A33 configures the CAN for a fast bit rate of 500 kBits/s.

The bit rate configured for the CAN FD data phase via DBTP must be higher or equal to the bit rate configured for the arbitration phase via NBTP.

Bit	31	30	29	28	27	26	25	24
Access								
Reset								
Bit	23	22	21	20	19	18	17	16
Access	TDC			DBRP[4:0]				
Reset	R/W			R/W	R/W	R/W	R/W	R/W
Reset	0			0	0	0	0	0
Bit	15	14	13	12	11	10	9	8
Access				DTSEG1[4:0]				
Reset				R/W	R/W	R/W	R/W	R/W
Reset				0	1	0	1	0
Bit	7	6	5	4	3	2	1	0
Access	DTSEG2[3:0]			DSJW[3:0]				
Reset	R/W	R/W	R/W	R/W	R/W	R/W	R/W	R/W
Reset	0	0	1	1	0	0	1	1

#### Bit 23 – TDC Transceiver Delay Compensation

Value	Description
0	Transceiver Delay Compensation disabled.
1	Transceiver Delay Compensation enabled.

#### Bits 20:16 – DBRP[4:0] Data Baud Rate Prescaler

Value	Description
0x00 – 0x1F	The value by which the oscillator frequency is divided for generating the bit time quanta. The bit time is built up from a multiple of this quanta. Valid values for the Baud Rate Prescaler are 0 to 31. The actual interpretation by the hardware of this value is such that one more than the value programmed here is used.

#### Bits 12:8 – DTSEG1[4:0] Fast time segment before sample point

Value	Description
0x00 – 0x1F	Valid values are 0 to 31. The actual interpretation by the hardware of this value is such that one more than the programmed value is used. DTSEG1 is the sum of Prop_Seg and Phase_Seg1.

#### Bits 7:4 – DTSEG2[3:0] Data time segment after sample point

Value	Description
0x0 - 0xF	Valid values are 0 to 15. The actual interpretation by the hardware of this value is such that one more than the programmed value is used. DTSEG2 is Phase_Seg2.

**Bits 3:0 - DSJW[3:0] Data (Re)Synchronization Jump Width**

Value	Description
0x0 - 0xF	Valid values are 0 to 15. The actual interpretation by the hardware of this value is such that one more than the programmed value is used.

### 38.8.5 Test

**Name:** TEST  
**Offset:** 0x10  
**Reset:** 0x00000000  
**Property:** Read-only, Write-restricted

Bit	31	30	29	28	27	26	25	24
Access								
Reset								
Bit	23	22	21	20	19	18	17	16
Access								
Reset								
Bit	15	14	13	12	11	10	9	8
Access								
Reset								
Bit	7	6	5	4	3	2	1	0
Access	RX	TX[1:0]		LBCK				
Reset	0	0	0	0				

#### Bit 7 – RX Receive Pin

Monitors the actual value of pin CAN\_RX

Value	Description
0	The CAN bus is dominant (CAN_RX = 0).
1	The CAN bus is recessive (CAN_RX = 1).

#### Bits 6:5 – TX[1:0] Control of Transmit Pin

This field defines the control of the transmit pin.

Value	Name	Description
0x0	CORE	Reset value, CAN_TX controlled by CAN core, updated at the end of CAN bit time.
0x1	SAMPLE	Sample Point can be monitored at pin CAN_TX.
0x2	DOMINANT	Dominant ('0') level at pin CAN_TX.
0x3	RECESSIVE	Recessive ('1') level at pin CAN_TX.

#### Bit 4 – LBCK Loop Back Mode

Value	Description
0	Loop Back Mode is disabled.
1	Loop Back Mode is enabled.

### 38.8.6 RAM Watchdog

**Name:** RWD  
**Offset:** 0x14  
**Reset:** 0x00000000  
**Property:** Read-only, Write-restricted

This register is write-restricted and only writable if bit fields CCCR.CCE = 1 and CCCR.INIT = 1.

The RAM Watchdog monitors the READY output of the Message RAM. A Message RAM access via the CAN's AHB Host Interface starts the Message RAM Watchdog Counter with the value configured by RWD.WDC. The counter is reloaded with RWD.WDC when the Message RAM signals successful completion by activating its READY output. In case there is no response from the Message RAM until the counter has counted down to zero, the counter stops and interrupt IR.WDI is set.

Bit	31	30	29	28	27	26	25	24
Access								
Reset								
Bit	23	22	21	20	19	18	17	16
Access								
Reset								
Bit	15	14	13	12	11	10	9	8
Access	WDV[7:0]							
Reset	0	0	0	0	0	0	0	0
Bit	7	6	5	4	3	2	1	0
Access	WDC[7:0]							
Reset	0	0	0	0	0	0	0	0

**Bits 15:8 - WDV[7:0]** Watchdog Value  
Actual Message RAM Watchdog Counter Value.

**Bits 7:0 - WDC[7:0]** Watchdog Configuration  
Start value of the Message RAM Watchdog Counter. With the reset value of 0x00 the counter is disabled.

### 38.8.7 CC Control

**Name:** CCCR  
**Offset:** 0x18  
**Reset:** 0x00000001  
**Property:** Read-only, Write-restricted

Bit	31	30	29	28	27	26	25	24
Access								
Reset								
Bit	23	22	21	20	19	18	17	16
Access								
Reset								
Bit	15	14	13	12	11	10	9	8
Access		TXP	EFBI	PXHD			BRSE	FDOE
Reset		R/W	R/W	R/W			R/W	R/W
		0	0	0			0	0
Bit	7	6	5	4	3	2	1	0
Access	TEST	DAR	MON	CSR	CSA	ASM	CCE	INIT
Reset	R/W	R/W	R/W	R/W	R/W	R/W	R/W	R/W
	0	0	0	0	0	0	0	1

#### Bit 14 – TXP Transmit Pause

This bit field is write-restricted and only writable if bit fields CCE = 1 and INIT = 1.

Value	Description
0	Transmit pause disabled.
1	Transmit pause enabled. The CAN pauses for two CAN bit times before starting the next transmission after itself has successfully transmitted a frame.

#### Bit 13 – EFBI Edge Filtering during Bus Integration

Value	Description
0	Edge filtering is disabled.
1	Two consecutive dominant tq required to detect an edge for hard synchronization.

#### Bit 12 – PXHD Protocol Exception Handling Disable

**Note:** When protocol exception handling is disabled, the CAN will transmit an error frame when it detects a protocol exception condition.

Value	Description
0	Protocol exception handling enabled.
1	Protocol exception handling disabled.

#### Bit 9 – BRSE Bit Rate Switch Enable

**Note:** When CAN FD operation is disabled FDOE = 0, BRSE is not evaluated.

Value	Description
0	Bit rate switching for transmissions disabled.
1	Bit rate switching for transmissions enabled.

#### Bit 8 – FDOE FD Operation Enable

Value	Description
0	FD operation disabled.
1	FD operation enabled.

**Bit 7 – TEST** Test Mode Enable

This bit field is write-restricted.  
Writing a 0 to this field is always allowed.  
Writing a 1 to this field is only allowed if bit fields CCE = 1 and INIT = 1.

Value	Description
0	Normal operation. Register TEST holds reset values.
1	Test Mode, write access to register TEST enabled.

**Bit 6 – DAR** Disable Automatic Retransmission

This bit field is write-restricted and only writable if bit fields CCE = 1 and INIT = 1.

Value	Description
0	Automatic retransmission of messages not transmitted successfully enabled.
1	Automatic retransmission disabled.

**Bit 5 – MON** Bus Monitoring Mode

This bit field is write-restricted.  
Writing a 0 to this field is always allowed.  
Writing a 1 to this field is only allowed if bit fields CCE = 1 and INIT = 1.

Value	Description
0	Bus Monitoring Mode is disabled.
1	Bus Monitoring Mode is enabled.

**Bit 4 – CSR** Clock Stop Request

Value	Description
0	No clock stop is requested.
1	Clock stop requested. When clock stop is requested, first INIT and then CSA will be set after all pending transfer requests have been completed and the CAN bus reached idle.

**Bit 3 – CSA** Clock Stop Acknowledge

Value	Description
0	No clock stop acknowledged.
1	CAN may be set in power down by stopping CLK_CAN_APB and GCLK_CAN.

**Bit 2 – ASM** Restricted Operation Mode

This bit field is write-restricted.  
Writing a 0 to this field is always allowed.  
Writing a 1 to this field is only allowed if bit fields CCE = 1 and INIT = 1.

Value	Description
0	Normal CAN operation.
1	Restricted Operation Mode active.

**Bit 1 – CCE** Configuration Change Enable

This bit field is write-restricted and only writable if bit field INIT = 1.

Value	Description
0	The CPU has no write access to the protected configuration registers.
1	The CPU has write access to the protected configuration registers (while CCCR.INIT = 1).

**Bit 0 – INIT** Initialization

Due to the synchronization mechanism between the two clock domains, there may be a delay until the value written to INIT can be read back. The programmer has to assure that the previous value written to INIT has been accepted by reading INIT before setting INIT to a new value.

Value	Description
0	Normal Operation.

Value	Description
1	Initialization is started.



### 38.8.8 Nominal Bit Timing and Prescaler

**Name:** NBTP  
**Offset:** 0x1C  
**Reset:** 0x00000A33  
**Property:** Write-restricted

This register is write-restricted and only writable if bit fields CCCR.CCE = 1 and CCCR.INIT = 1.

The CAN bit time may be programmed in the range of 4 to 385 time quanta. The CAN time quantum may be programmed in the range of 1 to 512 GCLK\_CAN periods.  $t_q = (NBRP + 1) mtq$ .

NTSEG1 is the sum of Prop\_Seg and Phase\_Seg1. NTSEG2 is Phase\_Seg2.

Therefore the length of the bit time is (programmed values) [NTSEG1 + NTSEG2 + 3]  $t_q$  or (functional values) [Sync\_Seg + Prop\_Seg + Phase\_Seg1 + Phase\_Seg2]  $t_q$ .

The Information Processing Time (IPT) is zero, meaning the data for the next bit is available at the first clock edge after the sample point.

**Note:** With a CAN clock (GCLK\_CAN) of 8MHz, the reset value 0x06000A03 configures the CAN for a bit rate of 500 kBits/s.

Bit	31	30	29	28	27	26	25	24
	NSJW[6:0]							NBRP[8]
Access	R/W	R/W	R/W	R/W	R/W	R/W	R/W	R/W
Reset	0	0	0	0	0	1	1	0
Bit	23	22	21	20	19	18	17	16
	NBRP[7:0]							
Access	R/W	R/W	R/W	R/W	R/W	R/W	R/W	R/W
Reset	0	0	0	0	0	0	0	0
Bit	15	14	13	12	11	10	9	8
	NTSEG1[7:0]							
Access	R/W	R/W	R/W	R/W	R/W	R/W	R/W	R/W
Reset	0	0	0	0	1	0	1	0
Bit	7	6	5	4	3	2	1	0
		NTSEG2[6:0]						
Access		R/W	R/W	R/W	R/W	R/W	R/W	R/W
Reset		0	0	0	0	0	1	1

#### Bits 31:25 – NSJW[6:0] Nominal (Re)Synchronization Jump Width

Value	Description
0x00 – 0x7F	Valid values are 0 to 127. The actual interpretation by the hardware of this value is such that one more than the programmed value is used.

#### Bits 24:16 – NBRP[8:0] Nominal Baud Rate Prescaler

Value	Description
0x000 – 0x1FF	The value by which the oscillator frequency is divided for generating the bit time quanta. The bit time is built up from a multiple of this quanta. Valid values for the Baud Rate Prescaler are 0 to 511. The actual interpretation by the hardware of this value is such that one more than the value programmed here is used.

#### Bits 15:8 – NTSEG1[7:0] Nominal Time segment before sample point

Value	Description
0x00 – 0x7F	Valid values are 1 to 255. The actual interpretation by the hardware of this value is such that one more than the programmed value is used. NTSEG1 is the sum of Prop_Seg and Phase_Seg1.

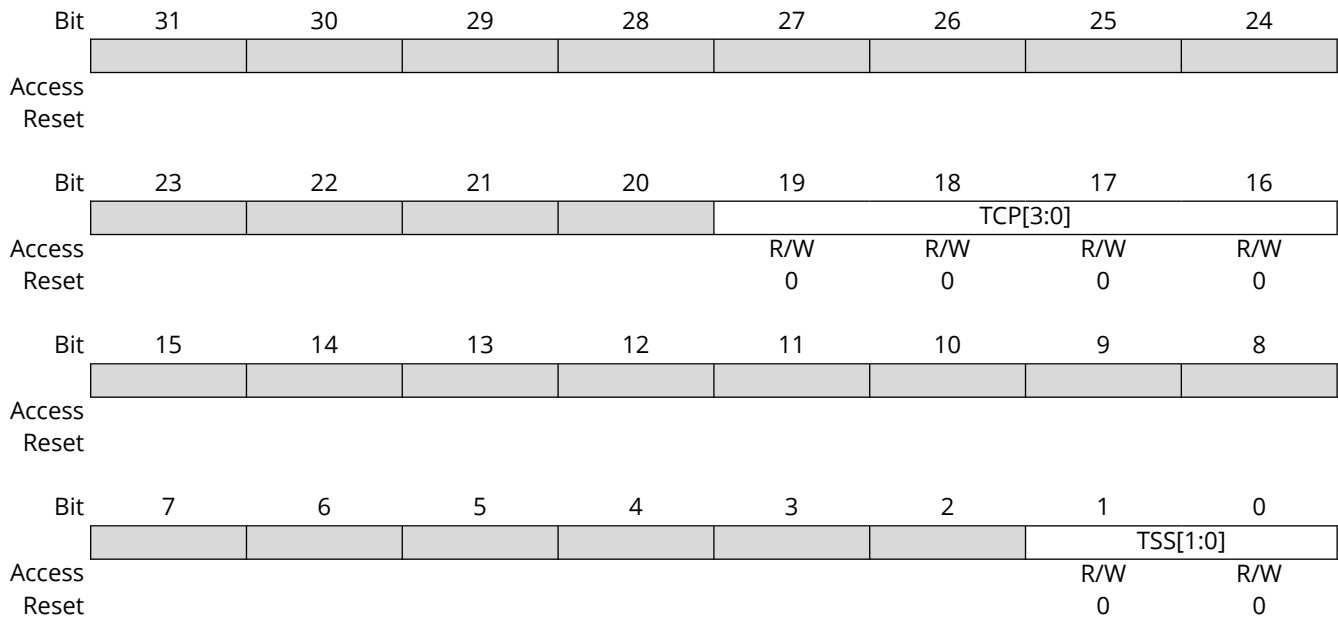
**Bits 6:0 – NTSEG2[6:0]** Time segment after sample point

Value	Description
0x00 – 0x7F	Valid values are 0 to 127. The actual interpretation by the hardware of this value is such that one more than the programmed value is used. NTSEG2 is Phase_Seg2.

### 38.8.9 Timestamp Counter Configuration

**Name:** TSCC  
**Offset:** 0x20  
**Reset:** 0x00000000  
**Property:** Write-restricted

This register is write-restricted and only writable if bit fields CCCR.CCE = 1 and CCCR.INIT = 1.



#### Bits 19:16 – TCP[3:0] Timestamp Counter Prescaler

Value	Description
0x0 – 0xF	Configures the timestamp and timeout counters time unit in multiples of CAN bit times [1...16]. The actual interpretation by the hardware of this value is such that one more than the value programmed here is used.

#### Bits 1:0 – TSS[1:0] Timestamp Select

This field defines the timestamp counter selection.

Value	Name	Description
0x0 or 0x3	ZERO	Timestamp counter value always 0x0000.
0x1	INC	Timestamp counter value incremented by TCP.
0x2	-	Reserved

### 38.8.10 Timestamp Counter Value

**Name:** TSCV  
**Offset:** 0x24  
**Reset:** 0x00000000  
**Property:** Read-only

**Notes:**

1. A write access to TSCV while in internal mode clears the Timestamp Counter value. A write access to TSCV while in external mode has no impact.
2. A “wrap around” is a change of the Timestamp Counter value from non-zero to zero not caused by the write access to TSCV.

Bit	31	30	29	28	27	26	25	24
Access								
Reset								
Bit	23	22	21	20	19	18	17	16
Access								
Reset								
Bit	15	14	13	12	11	10	9	8
TSC[15:8]								
Access	R	R	R	R	R	R	R	R
Reset	0	0	0	0	0	0	0	0
Bit	7	6	5	4	3	2	1	0
TSC[7:0]								
Access	R	R	R	R	R	R	R	R
Reset	0	0	0	0	0	0	0	0

**Bits 15:0 – TSC[15:0] Timestamp Counter**

The internal Timestamp Counter value is captured on start of frame (both Rx and Tx). When TSCC.TSS = 0x1, the Timestamp Counter is incremented in multiples of CAN bit times [1...16] depending on the configuration of TSCC.TCP. A wrap around sets interrupt flag IR.TSW.

### 38.8.11 Timeout Counter Configuration

**Name:** TOCC  
**Offset:** 0x28  
**Reset:** 0xFFFF0000  
**Property:** Write-restricted

This register is write-restricted and only writable if bit fields CCCR.CCE = 1 and CCCR.INIT = 1.

Bit	31	30	29	28	27	26	25	24
	TOP[15:8]							
Access	R/W	R/W	R/W	R/W	R/W	R/W	R/W	R/W
Reset	1	1	1	1	1	1	1	1
Bit	23	22	21	20	19	18	17	16
	TOP[7:0]							
Access	R/W	R/W	R/W	R/W	R/W	R/W	R/W	R/W
Reset	1	1	1	1	1	1	1	1
Bit	15	14	13	12	11	10	9	8
Access								
Reset								
Bit	7	6	5	4	3	2	1	0
						TOS[1:0]		ETOC
Access						R/W	R/W	R/W
Reset						0	0	0

#### Bits 31:16 – TOP[15:0] Timeout Period

Start value of the Timeout Counter (down-counter). Configures the Timeout Period.

#### Bits 2:1 – TOS[1:0] Timeout Select

When operating in Continuous mode, a write to TOCV presets the counter to the value configured by TOCC.TOP and continues down-counting. When the Timeout Counter is controlled by one of the FIFOs, an empty FIFO presets the counter to the value configured by TOCC.TOP. Down-counting is started when the first FIFO element is stored.

Value	Name	Description
0x0	CONT	Continuous operation.
0x1	TXEF	Timeout controlled by TX Event FIFO.
0x2	RXF0	Timeout controlled by Rx FIFO 0.
0x3	RXF1	Timeout controlled by Rx FIFO 1.

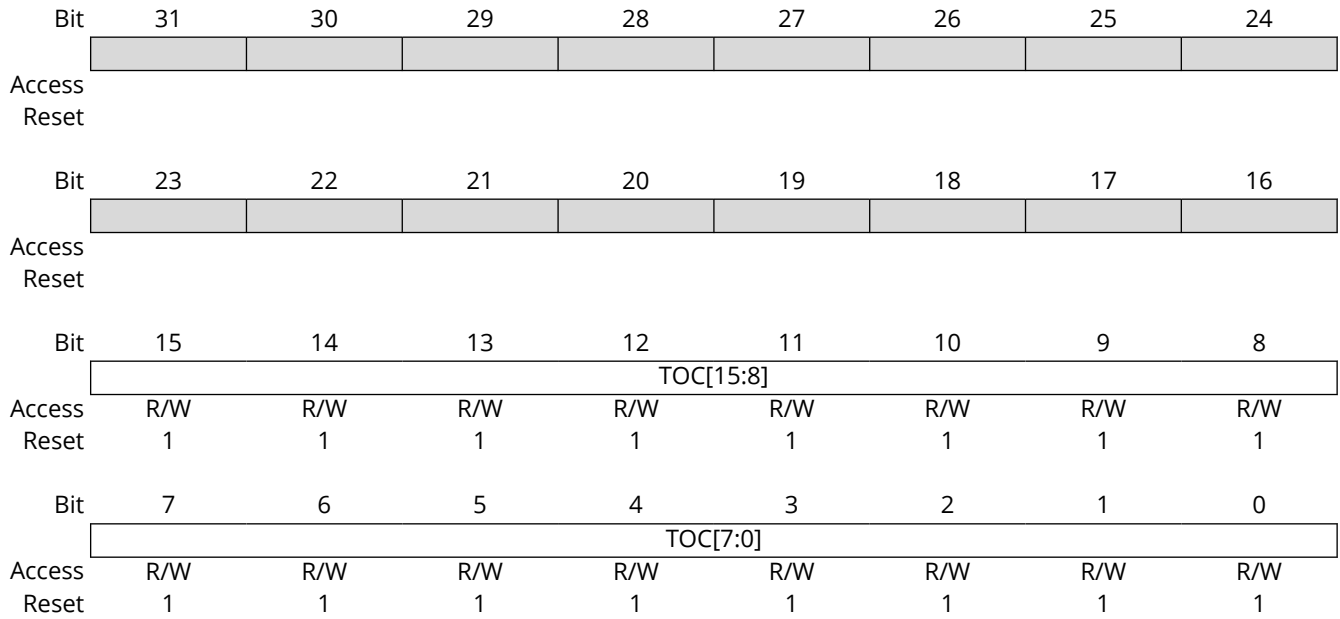
#### Bit 0 – ETOC Enable Timeout Counter

Value	Description
0	Timeout Counter disabled.
1	Timeout Counter enabled.

### 38.8.12 Timeout Counter Value

**Name:** TOCV  
**Offset:** 0x2C  
**Reset:** 0x0000FFFF  
**Property:** Read-only

**Note:** A write access to TOCV reloads the Timeout Counter with the value of TOCV.TOP.



#### Bits 15:0 – TOC[15:0] Timeout Counter

The Timeout Counter is decremented in multiples of CAN bit times [1...16] depending on the configuration of TSCC.TCP. When decremented to zero, interrupt flag IR.TOO is set and the Timeout Counter is stopped. Start and reset/restart conditions are configured via TOCC.TOS.

### 38.8.13 Error Counter

**Name:** ECR  
**Offset:** 0x40  
**Reset:** 0x00000000  
**Property:** Read-only

**Note:** When CCCR.ASM is set, the CAN protocol controller does not increment TEC and REC when a CAN protocol error is detected, but CEL is still incremented.

Bit	31	30	29	28	27	26	25	24
Access								
Reset								
Bit	23	22	21	20	19	18	17	16
Access	CEL[7:0]							
Reset	0	0	0	0	0	0	0	0
Bit	15	14	13	12	11	10	9	8
Access	RP	REC[6:0]						
Reset	0	0	0	0	0	0	0	0
Bit	7	6	5	4	3	2	1	0
Access	TEC[7:0]							
Reset	0	0	0	0	0	0	0	0

#### Bits 23:16 – CEL[7:0] CAN Error Logging

The counter is incremented each time when a CAN protocol error causes the Transmit Error Counter or Receive Error Counter to be incremented. It is reset by read access to CEL. The counter stops at 0xFF; the next increment of TEC or REC sets interrupt flag IR.ELO.

#### Bit 15 – RP Receive Error Passive

#### Bits 14:8 – REC[6:0] Receive Error Counter

Actual state of the Receive Error Counter, values between 0 and 127.

#### Bits 7:0 – TEC[7:0] Transmit Error Counter

Actual state of the Transmit Error Counter, values between 0 and 255.

### 38.8.14 Protocol Status

**Name:** PSR  
**Offset:** 0x44  
**Reset:** 0x00000707  
**Property:** Read-only

**Notes:**

1. When a frame in CAN FD format has reached the data phase with BRS flag set, the next CAN event (error or valid frame) will be shown in FLEC instead of LEC. An error in a fixed stuff bit of a CAN FD CRC sequence will be shown as a Form Error, not Stuff Error.
2. The Bus\_Off recovery sequence (see CAN Specification Rev. 2.0 or ISO 11898-1) cannot be shortened by setting or resetting CCCR.INIT. If the device goes Bus\_Off, it will set CCCR.INIT of its own accord, stopping all bus activities. Once CCCR.INIT has been cleared by the CPU, the device will then wait for 129 occurrences of Bus Idle (129 \* 11 consecutive recessive bits) before resuming normal operation. At the end of the Bus\_Off recovery sequence, the Error Management Counters will be reset. During the waiting time after the resetting of CCCR.INIT, each time a sequence of 11 recessive bits has been monitored, a Bit0 Error code is written to PSR.LEC, enabling the CPU to readily check up whether the CAN bus is stuck at dominant or continuously disturbed and to monitor the Bus\_Off recovery sequence. ECR.REC is used to count these sequences.

Bit	31	30	29	28	27	26	25	24
Access								
Reset								
Bit	23	22	21	20	19	18	17	16
Access		TDCV[6:0]						
Reset		R	R	R	R	R	R	R
Reset		0	0	0	0	0	0	0
Bit	15	14	13	12	11	10	9	8
Access		PXE	RFDF	RBRS	RESI	DLEC[2:0]		
Reset		R	R	R	R	R	R	R
Reset		0	0	0	0	1	1	1
Bit	7	6	5	4	3	2	1	0
Access	BO	EW	EP	ACT[1:0]		LEC[2:0]		
Reset	R	R	R	R	R	R	R	R
Reset	0	0	0	0	0	1	1	1

#### Bits 22:16 – TDCV[6:0] Transmitter Delay Compensation Value

Value	Description
0x00 – 0x7F	Position of the secondary sample point, defined by the sum of the measured delay from CAN_TX to CAN_RX and TDCR.TDCO. The SSP position is, in the data phase, the number of mtq between the start of the transmitted bit and the secondary sample point. Valid values are 0 to 127 mtq.

#### Bit 14 – PXE Protocol Exception Event

This field is cleared on read access.

Value	Description
0	No protocol exception event occurred since last read access.
1	Protocol exception event occurred.



**Bit 13 – RPDF** Received a CAN FD Message

This field is cleared on read access.

Value	Description
0	Since this bit was reset by the CPU, no CAN FD message has been received.
1	Message in CAN FD format with RPDF flag set has been received. This bit is set independent of acceptance filtering.

**Bit 12 – RBRS** BRS flag of last received CAN FD Message

This field is cleared on read access.

Value	Description
0	Last received CAN FD message did not have its BRS flag set.
1	Last received CAN FD message had its BRS flag set. This bit is set together with RPDF, independent of acceptance filtering.

**Bit 11 – RESI** ESI flag of last received CAN FD Message

This field is cleared on read access.

Value	Description
0	Last received CAN FD message did not have its ESI flag set.
1	Last received CAN FD message had its ESI flag set.

**Bits 10:8 – DLEC[2:0]** Data Last Error Code

Type of last error that occurred in the data phase of a CAN FD format frame with its BRS flag set. Coding is the same as for LEC. This field will be cleared to zero when a CAN FD format frame with its BRS flag set has been transferred (reception or transmission) without error.

**Bit 7 – BO** Bus\_Off Status

Value	Description
0	The CAN is not Bus_Off.
1	The CAN is in Bus_Off state.

**Bit 6 – EW** Error Warning Status

Value	Description
0	Both error counters are below the Error_Warning limit of 96.
1	At least one of the error counter has reached the Error_Warning limit of 96.

**Bit 5 – EP** Error Passive

Value	Description
0	The CAN is in the Error_Active state. It normally takes part in bus communication and sends an active error flag when an error has been detected.
1	The CAN is in the Error_Passive state.

**Bits 4:3 – ACT[1:0]** Activity

Monitors the module's CAN communication state.

Value	Name	Description
0x0	SYNC	Node is synchronizing on CAN communication.
0x1	IDLE	Node is neither receiver nor transmitter.
0x2	RX	Node is operating as receiver.
0x3	TX	Node is operating as transmitter.

**Bits 2:0 – LEC[2:0]** Last Error Code

The LEC indicates the type of the last error to occur on the CAN bus. This field will be cleared to '0' when a message has been transferred (reception or transmission) without error.

This field is set on read access.

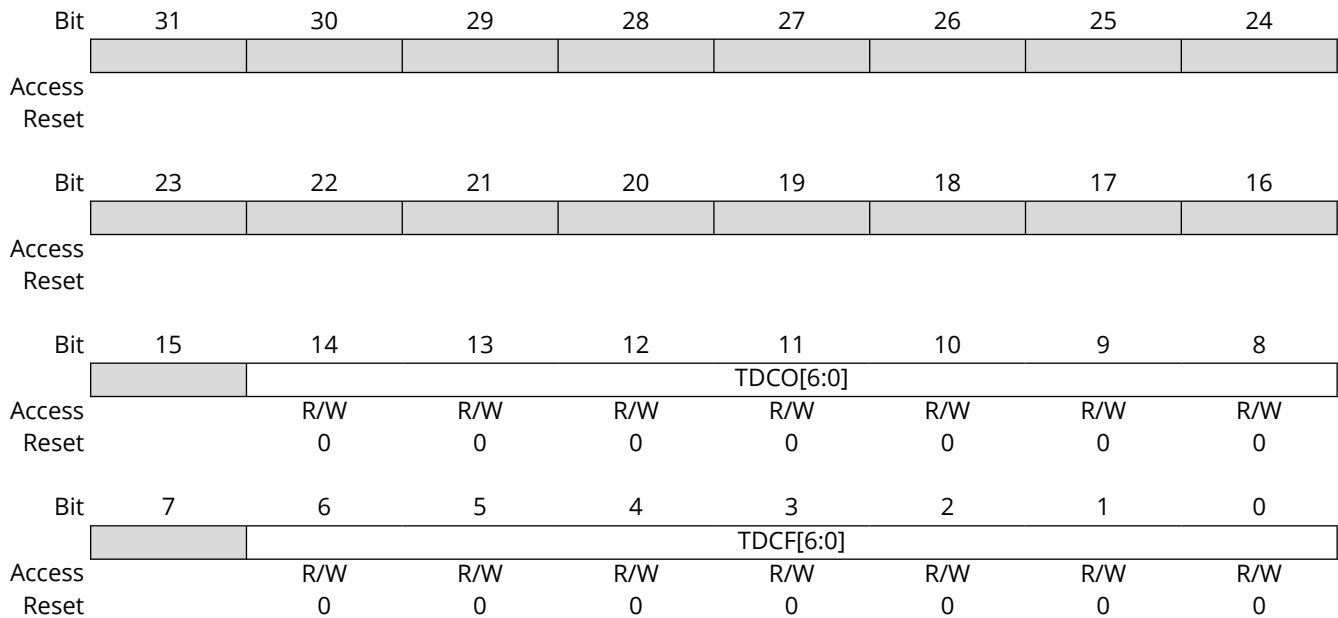
Value	Name	Description
0x0	NONE	No Error: No error occurred since LEC has been reset by successful reception or transmission.
0x1	STUFF	Stuff Error: More than 5 equal bits in a sequence have occurred in a part of a received message where this is not allowed.

Value	Name	Description
0x2	FORM	Form Error: A fixed format part of a received frame has the wrong format.
0x3	ACK	Ack Error: The message transmitted by the CAN was not acknowledged by another node.
0x4	BIT1	Bit1 Error: During the transmission of a message (with the exception of the arbitration field), the device wanted to send a recessive level (bit of logical value '1'), but the monitored bus was dominant.
0x5	BIT0	Bit0 Error: During the transmission of a message (or acknowledge bit, or active error flag, or overload flag), the device wanted to send a dominant level (data or identifier bit logical value '0'), but the monitored bus value was recessive. During Bus_Off recovery this status is set each time a sequence of 11 recessive bits have been monitored. This enables the CPU to monitor the proceeding of the Bus_Off recovery sequence (indicating the bus is not stuck at dominant or continuously disturbed).
0x6	CRC	CRC Error: The CRC checksum of a received message was incorrect. The CRC of an incoming message does not match with the CRC calculated from the received data.
0x7	NC	No Change: Any read access to the Protocol Status Register re-initializes the LEC to '7'. When the LEC shows the value '7', no CAN bus event was detected since the last CPU read access to the Protocol Status Register.

### 38.8.15 Transmitter Delay Compensation

**Name:** TDCR  
**Offset:** 0x48  
**Reset:** 0x00000000  
**Property:** Write-restricted

This register is write-restricted and only writable if bit fields CCCR.CCE = 1 and CCCR.INIT = 1.



#### Bits 14:8 – TDCO[6:0] Transmitter Delay Compensation Offset

Value	Description
0x00 – 0x7F	Offset value defining the distance between the measured delay from CAN_TX to CAN_RX and the secondary sample point. Valid values are 0 to 127 mtq.

#### Bits 6:0 – TDCF[6:0] Transmitter Delay Compensation Filter Window Length

Value	Description
0x00 – 0x7F	Defines the minimum value for the SSP position, dominant edges on CAN_RX that would result in an earlier SSP position are ignored for transmitter delay measurement. The feature is enabled when TDCF is configured to a value greater than TDCO. Valid values are 0 to 127 mtq.

### 38.8.16 Interrupt

**Name:** IR  
**Offset:** 0x50  
**Reset:** 0x00000000  
**Property:** -

The flags are set when one of the listed conditions is detected (edge-sensitive). A flag is cleared by writing a 1 to the corresponding bit field. Writing a 0 has no effect. A hard reset will clear the register.

Bit	31	30	29	28	27	26	25	24
			ARA	PED	PEA	WDI	BO	EW
Access			R/W	R/W	R/W	R/W	R/W	R/W
Reset			0	0	0	0	0	0
Bit	23	22	21	20	19	18	17	16
	EP	ELO	BEU	BEC	DRX	TOO	MRAF	TSW
Access	R/W	R/W	R/W	R/W	R/W	R/W	R/W	R/W
Reset	0	0	0	0	0	0	0	0
Bit	15	14	13	12	11	10	9	8
	TEFL	TEFF	TEFW	TEFN	TFE	TCF	TC	HPM
Access	R/W	R/W	R/W	R/W	R/W	R/W	R/W	R/W
Reset	0	0	0	0	0	0	0	0
Bit	7	6	5	4	3	2	1	0
	RF1L	RF1F	RF1W	RF1N	RF0L	RF0F	RF0W	RF0N
Access	R/W	R/W	R/W	R/W	R/W	R/W	R/W	R/W
Reset	0	0	0	0	0	0	0	0

#### Bit 29 – ARA Access to Reserved Address

Value	Description
0	No access to reserved address occurred.
1	Access to reserved address occurred.

#### Bit 28 – PED Protocol Error in Data Phase

Value	Description
0	No protocol error in data phase.
1	Protocol error in data phase detected (PSR.DLEC != 0,7).

#### Bit 27 – PEA Protocol Error in Arbitration Phase

Value	Description
0	No protocol error in arbitration phase.
1	Protocol error in arbitration phase detected (PSR.LEC != 0,7).

#### Bit 26 – WDI Watchdog Interrupt

Value	Description
0	No Message RAM Watchdog event occurred.
1	Message RAM Watchdog event due to missing READY.

#### Bit 25 – BO Bus\_Off Status

Value	Description
0	Bus_Off status unchanged.
1	Bus_Off status changed.

**Bit 24 – EW Error Warning Status**

Value	Description
0	Error_Warning status unchanged.
1	Error_Warning status changed.

**Bit 23 – EP Error Passive**

Value	Description
0	Error_Passive status unchanged.
1	Error_Passive status changed.

**Bit 22 – ELO Error Logging Overflow**

Value	Description
0	CAN Error Logging Counter did not overflow.
1	Overflow of CAN Error Logging Counter occurred.

**Bit 21 – BEU Bit Error Uncorrected**

Message RAM bit error detected, uncorrected. Generated by an optional external parity / ECC logic attached to the Message RAM. An uncorrected Message RAM bit sets CCCR.INIT to 1. This is done to avoid transmission of corrupted data.

Value	Description
0	Not bit error detected when reading from Message RAM.
1	Bit error detected, uncorrected (e.g. parity logic).

**Bit 20 – BEC Bit Error Corrected**

Message RAM bit error detected and corrected. Generated by an optional external parity / ECC logic attached to the Message RAM.

Value	Description
0	Not bit error detected when reading from Message RAM.
1	Bit error detected and corrected (e.g. ECC).

**Bit 19 – DRX Message stored to Dedicated Rx Buffer**

The flag is set whenever a received message has been stored into a dedicated Rx Buffer.

Value	Description
0	No Rx Buffer updated.
1	At least one received message stored into a Rx Buffer.

**Bit 18 – TOO Timeout Occurred**

Value	Description
0	No timeout.
1	Timeout reached.

**Bit 17 – MRAF Message RAM Access Failure**

The flag is set, when the Rx Handler

- has not completed acceptance filtering or storage of an accepted message until the arbitration field of the following message has been received. In this case acceptance filtering or message storage is aborted and the Rx Handler starts processing of the following message.
- was not able to write a message to the Message RAM. In this case message storage is aborted.

In both cases the FIFO put index is not updated resp. the New Data flag for a dedicated Rx Buffer is not set, a partly stored message is overwritten when the next message is stored to this location. The flag is also set when the Tx Handler was not able to read a message from the Message RAM in time. In this case message transmission is aborted. In case of a Tx Handler access failure the CAN is switched into Restricted Operation Mode. To leave Restricted Operation Mode, the Host CPU has to reset CCCR.ASM.

Value	Description
0	No Message RAM access failure occurred.

Value	Description
1	Message RAM access failure occurred.

**Bit 16 – TSW** Timestamp Wraparound

Value	Description
0	No timestamp counter wrap-around.
1	Timestamp counter wrapped around.

**Bit 15 – TEFL** Tx Event FIFO Element Lost

Value	Description
0	No Tx Event FIFO element lost.
1	Tx Event FIFO element lost, also set after write attempt to Tx Event FIFO of size zero.

**Bit 14 – TEFF** Tx Event FIFO Full

Value	Description
0	Tx Event FIFO not full.
1	Tx Event FIFO full.

**Bit 13 – TEFW** Tx Event FIFO Watermark Reached

Value	Description
0	Tx Event FIFO fill level below watermark.
1	Tx Event FIFO fill level reached watermark.

**Bit 12 – TEFN** Tx Event FIFO New Entry

Value	Description
0	Tx Event FIFO unchanged.
1	Tx Handler wrote Tx Event FIFO element.

**Bit 11 – TFE** Tx FIFO Empty

Value	Description
0	Tx FIFO non-empty.
1	Tx FIFO empty.

**Bit 10 – TCF** Transmission Cancellation Finished

Value	Description
0	No transmission cancellation finished.
1	Transmission cancellation finished.

**Bit 9 – TC** Timestamp Completed

Value	Description
0	Timestamp not completed.
1	Timestamp completed.

**Bit 8 – HPM** High Priority Message

Value	Description
0	No high priority message received.
1	High priority message received.

**Bit 7 – RF1L** Rx FIFO 1 Message Lost

Value	Description
0	No Rx FIFO 1 message lost.
1	Rx FIFO 1 message lost, also set after write attempt to Rx FIFO 1 of size zero.

**Bit 6 – RF1F** Rx FIFO 1 Full

Value	Description
0	Rx FIFO 1 not full.
1	Rx FIFO 1 full.

**Bit 5 – RF1W** Rx FIFO 1 Watermark Reached

Value	Description
0	Rx FIFO 1 fill level below watermark.
1	Rx FIFO 1 fill level reached watermark.

**Bit 4 – RF1N** Rx FIFO 1 New Message

Value	Description
0	No new message written to Rx FIFO 1.
1	New message written to Rx FIFO 1.

**Bit 3 – RF0L** Rx FIFO 0 Message Lost

Value	Description
0	No Rx FIFO 0 message lost.
1	Rx FIFO 0 message lost. also set after write attempt to Rx FIFO 0 of size zero.

**Bit 2 – RF0F** Rx FIFO 0 Full

Value	Description
0	Rx FIFO 0 not full.
1	Rx FIFO 0 full.

**Bit 1 – RF0W** Rx FIFO 0 Watermark Reached

Value	Description
0	Rx FIFO 0 fill level below watermark.
1	Rx FIFO 0 fill level reached watermark.

**Bit 0 – RF0N** Rx FIFO 0 New Message

Value	Description
0	No new message written to Rx FIFO 0.
1	New message written to Rx FIFO 0.

### 38.8.17 Interrupt Enable

**Name:** IE  
**Offset:** 0x54  
**Reset:** 0x00000000  
**Property:** -

The settings in the Interrupt Enable register determine which status changes in the Interrupt Register will be signalled on an interrupt line.

Bit	31	30	29	28	27	26	25	24
			ARAE	PEDE	PEAE	WDIE	BOE	EWE
Access			R/W	R/W	R/W	R/W	R/W	R/W
Reset			0	0	0	0	0	0
Bit	23	22	21	20	19	18	17	16
	EPE	ELOE	BEUE	BECE	DRXE	TOOE	MRAFE	TSWE
Access	R/W	R/W	R/W	R/W	R/W	R/W	R/W	R/W
Reset	0	0	0	0	0	0	0	0
Bit	15	14	13	12	11	10	9	8
	TEFLE	TEFFE	TEFWE	TEFNE	TFEE	TCFE	TCE	HPME
Access	R/W	R/W	R/W	R/W	R/W	R/W	R/W	R/W
Reset	0	0	0	0	0	0	0	0
Bit	7	6	5	4	3	2	1	0
	RF1LE	RF1FE	RF1WE	RF1NE	RFOLE	RFOFE	RFOWE	RFONE
Access	R/W	R/W	R/W	R/W	R/W	R/W	R/W	R/W
Reset	0	0	0	0	0	0	0	0

#### Bit 29 – ARAE Access to Reserved Address Interrupt Enable

Value	Description
0	Interrupt disabled.
1	Interrupt enabled.

#### Bit 28 – PEDE Protocol Error in Data Phase Interrupt Enable

Value	Description
0	Interrupt disabled.
1	Interrupt enabled.

#### Bit 27 – PEAE Protocol Error in Arbitration Phase Interrupt Enable

Value	Description
0	Interrupt disabled.
1	Interrupt enabled.

#### Bit 26 – WDIE Watchdog Interrupt Enable

Value	Description
0	Interrupt disabled.
1	Interrupt enabled.

#### Bit 25 – BOE Bus\_Off Status Interrupt Enable

Value	Description
0	Interrupt disabled.
1	Interrupt enabled.



**Bit 24 – EWE** Error Warning Status Interrupt Enable

Value	Description
0	Interrupt disabled.
1	Interrupt enabled.

**Bit 23 – EPE** Error Passive Interrupt Enable

Value	Description
0	Interrupt disabled.
1	Interrupt enabled.

**Bit 22 – ELOE** Error Logging Overflow Interrupt Enable

Value	Description
0	Interrupt disabled.
1	Interrupt enabled.

**Bit 21 – BEUE** Bit Error Uncorrected Interrupt Enable.

Value	Description
0	Interrupt disabled.
1	Interrupt enabled.

**Bit 20 – BECE** Bit Error Corrected Interrupt Enable

Value	Description
0	Interrupt disabled.
1	Interrupt enabled.

**Bit 19 – DRXE** Message stored to Dedicated Rx Buffer Interrupt Enable

Value	Description
0	Interrupt disabled.
1	Interrupt enabled.

**Bit 18 – TOOE** Timeout Occurred Interrupt Enable

Value	Description
0	Interrupt disabled.
1	Interrupt enabled.

**Bit 17 – MRAFE** Message RAM Access Failure Interrupt Enable

Value	Description
0	Interrupt disabled.
1	Interrupt enabled.

**Bit 16 – TSWE** Timestamp Wraparound Interrupt Enable

Value	Description
0	Interrupt disabled.
1	Interrupt enabled.

**Bit 15 – TEFLE** Tx Event FIFO Event Lost Interrupt Enable

Value	Description
0	Interrupt disabled.
1	Interrupt enabled.

**Bit 14 – TEFFE** Tx Event FIFO Full Interrupt Enable

Value	Description
0	Interrupt disabled.
1	Interrupt enabled.

**Bit 13 – TEFWE** Tx Event FIFO Watermark Reached Interrupt Enable

Value	Description
0	Interrupt disabled.
1	Interrupt enabled.

**Bit 12 – TEFNE** Tx Event FIFO New Entry Interrupt Enable

Value	Description
0	Interrupt disabled.
1	Interrupt enabled.

**Bit 11 – TFEE** Tx FIFO Empty Interrupt Enable

Value	Description
0	Interrupt disabled.
1	Interrupt enabled.

**Bit 10 – TCFE** Transmission Cancellation Finished Interrupt Enable

Value	Description
0	Interrupt disabled.
1	Interrupt enabled.

**Bit 9 – TCE** Transmission Completed Interrupt Enable

Value	Description
0	Interrupt disabled.
1	Interrupt enabled.

**Bit 8 – HPME** High Priority Message Interrupt Enable

Value	Description
0	Interrupt disabled.
1	Interrupt enabled.

**Bit 7 – RF1LE** Rx FIFO 1 Message Lost Interrupt Enable

Value	Description
0	Interrupt disabled.
1	Interrupt enabled.

**Bit 6 – RF1FE** Rx FIFO 1 Full Interrupt Enable

Value	Description
0	Interrupt disabled.
1	Interrupt enabled.

**Bit 5 – RF1WE** Rx FIFO 1 Watermark Reached Interrupt Enable

Value	Description
0	Interrupt disabled.
1	Interrupt enabled.

**Bit 4 – RF1NE** Rx FIFO 1 New Message Interrupt Enable

Value	Description
0	Interrupt disabled.
1	Interrupt enabled.

**Bit 3 – RF0LE** Rx FIFO 0 Message Lost Interrupt Enable

Value	Description
0	Interrupt disabled.
1	Interrupt enabled.

**Bit 2 – RF0FE** Rx FIFO 0 Full Interrupt Enable

Value	Description
0	Interrupt disabled.

Value	Description
1	Interrupt enabled.

**Bit 1 – RF0WE** Rx FIFO 0 Watermark Reached Interrupt Enable

Value	Description
0	Interrupt disabled.
1	Interrupt enabled.

**Bit 0 – RF0NE** Rx FIFO 0 New Message Interrupt Enable

Value	Description
0	Interrupt disabled.
1	Interrupt enabled.

### 38.8.18 Interrupt Line Select

**Name:** ILS  
**Offset:** 0x58  
**Reset:** 0x00000000  
**Property:** -

The Interrupt Line Select register assigns an interrupt generated by a specific interrupt flag from IR to one of the two module interrupt lines.

Bit	31	30	29	28	27	26	25	24
			ARAL	PEDL	PEAL	WDIL	BOL	EWL
Access			R/W	R/W	R/W	R/W	R/W	R/W
Reset			0	0	0	0	0	0
Bit	23	22	21	20	19	18	17	16
	EPL	ELOL	BEUL	BECL	DRXL	TOOL	MRAFL	TSWL
Access	R/W	R/W	R/W	R/W	R/W	R/W	R/W	R/W
Reset	0	0	0	0	0	0	0	0
Bit	15	14	13	12	11	10	9	8
	TEFLL	TEFFL	TEFWL	TEFNL	TFEL	TCFL	TCL	HPML
Access	R/W	R/W	R/W	R/W	R/W	R/W	R/W	R/W
Reset	0	0	0	0	0	0	0	0
Bit	7	6	5	4	3	2	1	0
	RF1LL	RF1FL	RF1WL	RF1NL	RFOLL	RF0FL	RF0WL	RF0NL
Access	R/W	R/W	R/W	R/W	R/W	R/W	R/W	R/W
Reset	0	0	0	0	0	0	0	0

#### Bit 29 – ARAL Access to Reserved Address Interrupt Line

Value	Description
0	Interrupt assigned to CAN interrupt line 0.
1	Interrupt assigned to CAN interrupt line 1.

#### Bit 28 – PEDL Protocol Error in Data Phase Interrupt Line

Value	Description
0	Interrupt assigned to CAN interrupt line 0.
1	Interrupt assigned to CAN interrupt line 1.

#### Bit 27 – PEAL Protocol Error in Arbitration Phase Interrupt Line

Value	Description
0	Interrupt assigned to CAN interrupt line 0.
1	Interrupt assigned to CAN interrupt line 1.

#### Bit 26 – WDIL Watchdog Interrupt Line

Value	Description
0	Interrupt assigned to CAN interrupt line 0.
1	Interrupt assigned to CAN interrupt line 1.

#### Bit 25 – BOL Bus\_Off Status Interrupt Line

Value	Description
0	Interrupt assigned to CAN interrupt line 0.
1	Interrupt assigned to CAN interrupt line 1.

**Bit 24 – EWL Error Warning Status Interrupt Line**

Value	Description
0	Interrupt assigned to CAN interrupt line 0.
1	Interrupt assigned to CAN interrupt line 1.

**Bit 23 – EPL Error Passive Interrupt Line**

Value	Description
0	Interrupt assigned to CAN interrupt line 0.
1	Interrupt assigned to CAN interrupt line 1.

**Bit 22 – ELOL Error Logging Overflow Interrupt Line**

Value	Description
0	Interrupt assigned to CAN interrupt line 0.
1	Interrupt assigned to CAN interrupt line 1.

**Bit 21 – BEUL Bit Error Uncorrected Interrupt Line**

Value	Description
0	Interrupt assigned to CAN interrupt line 0.
1	Interrupt assigned to CAN interrupt line 1.

**Bit 20 – BECL Bit Error Corrected Interrupt Line**

Value	Description
0	Interrupt assigned to CAN interrupt line 0.
1	Interrupt assigned to CAN interrupt line 1.

**Bit 19 – DRXL Message stored to Dedicated Rx Buffer Interrupt Line**

Value	Description
0	Interrupt assigned to CAN interrupt line 0.
1	Interrupt assigned to CAN interrupt line 1.

**Bit 18 – TOOL Timeout Occurred Interrupt Line**

Value	Description
0	Interrupt assigned to CAN interrupt line 0.
1	Interrupt assigned to CAN interrupt line 1.

**Bit 17 – MRAFL Message RAM Access Failure Interrupt Line**

Value	Description
0	Interrupt assigned to CAN interrupt line 0.
1	Interrupt assigned to CAN interrupt line 1.

**Bit 16 – TSWL Timestamp Wraparound Interrupt Line**

Value	Description
0	Interrupt assigned to CAN interrupt line 0.
1	Interrupt assigned to CAN interrupt line 1.

**Bit 15 – TEFLL Tx Event FIFO Event Lost Interrupt Line**

Value	Description
0	Interrupt assigned to CAN interrupt line 0.
1	Interrupt assigned to CAN interrupt line 1.

**Bit 14 – TEFFL Tx Event FIFO Full Interrupt Line**

Value	Description
0	Interrupt assigned to CAN interrupt line 0.
1	Interrupt assigned to CAN interrupt line 1.

**Bit 13 – TEFWL Tx Event FIFO Watermark Reached Interrupt Line**

Value	Description
0	Interrupt assigned to CAN interrupt line 0.
1	Interrupt assigned to CAN interrupt line 1.

**Bit 12 – TEFNL Tx Event FIFO New Entry Interrupt Line**

Value	Description
0	Interrupt assigned to CAN interrupt line 0.
1	Interrupt assigned to CAN interrupt line 1.

**Bit 11 – TFEL Tx FIFO Empty Interrupt Line**

Value	Description
0	Interrupt assigned to CAN interrupt line 0.
1	Interrupt assigned to CAN interrupt line 1.

**Bit 10 – TCFL Transmission Cancellation Finished Interrupt Line**

Value	Description
0	Interrupt assigned to CAN interrupt line 0.
1	Interrupt assigned to CAN interrupt line 1.

**Bit 9 – TCL Transmission Completed Interrupt Line**

Value	Description
0	Interrupt assigned to CAN interrupt line 0.
1	Interrupt assigned to CAN interrupt line 1.

**Bit 8 – HPML High Priority Message Interrupt Line**

Value	Description
0	Interrupt assigned to CAN interrupt line 0.
1	Interrupt assigned to CAN interrupt line 1.

**Bit 7 – RF1LL Rx FIFO 1 Message Lost Interrupt Line**

Value	Description
0	Interrupt assigned to CAN interrupt line 0.
1	Interrupt assigned to CAN interrupt line 1.

**Bit 6 – RF1FL Rx FIFO 1 Full Interrupt Line**

Value	Description
0	Interrupt assigned to CAN interrupt line 0.
1	Interrupt assigned to CAN interrupt line 1.

**Bit 5 – RF1WL Rx FIFO 1 Watermark Reached Interrupt Line**

Value	Description
0	Interrupt assigned to CAN interrupt line 0.
1	Interrupt assigned to CAN interrupt line 1.

**Bit 4 – RF1NL Rx FIFO 1 New Message Interrupt Line**

Value	Description
0	Interrupt assigned to CAN interrupt line 0.
1	Interrupt assigned to CAN interrupt line 1.

**Bit 3 – RF0LL Rx FIFO 0 Message Lost Interrupt Line**

Value	Description
0	Interrupt assigned to CAN interrupt line 0.
1	Interrupt assigned to CAN interrupt line 1.

**Bit 2 – RF0FL Rx FIFO 0 Full Interrupt Line**

Value	Description
0	Interrupt assigned to CAN interrupt line 0.

Value	Description
1	Interrupt assigned to CAN interrupt line 1.

**Bit 1 – RF0WL** Rx FIFO 0 Watermark Reached Interrupt Line

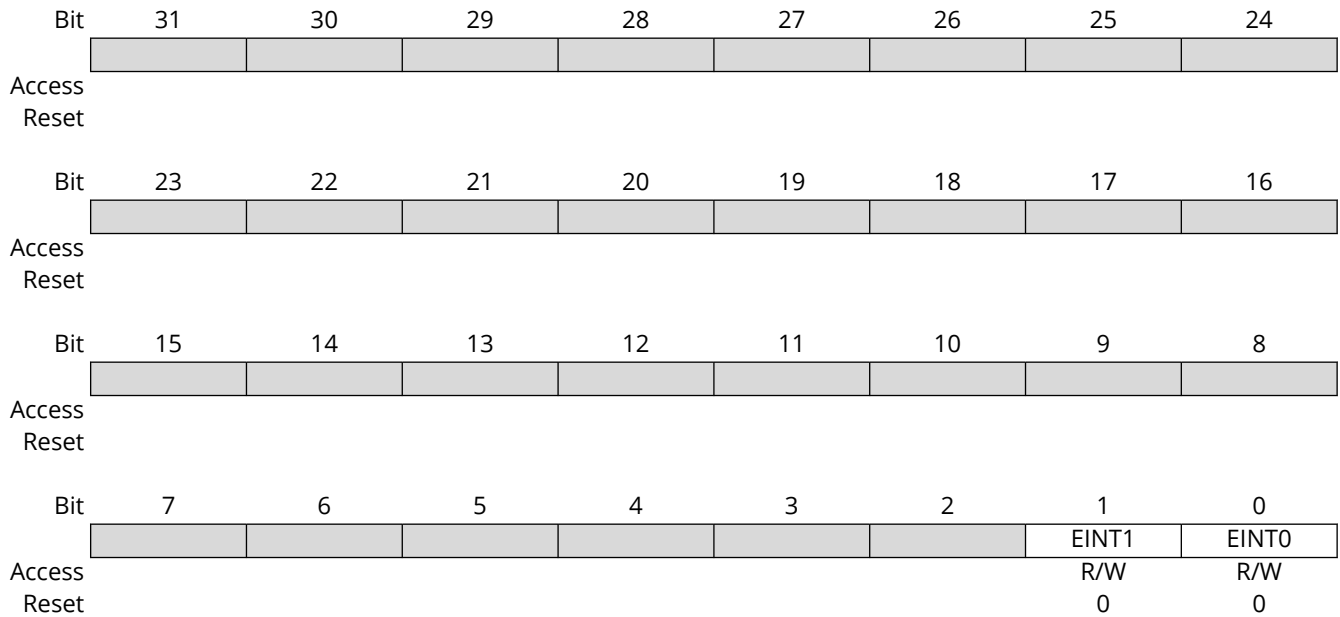
Value	Description
0	Interrupt assigned to CAN interrupt line 0.
1	Interrupt assigned to CAN interrupt line 1.

**Bit 0 – RF0NL** Rx FIFO 0 New Message Interrupt Line

Value	Description
0	Interrupt assigned to CAN interrupt line 0.
1	Interrupt assigned to CAN interrupt line 1.

### 38.8.19 Interrupt Line Enable

**Name:** ILE  
**Offset:** 0x5C  
**Reset:** 0x00000000  
**Property:** -



#### Bits 0, 1 - EINTn Enable Interrupt Line n [n = 1,0]

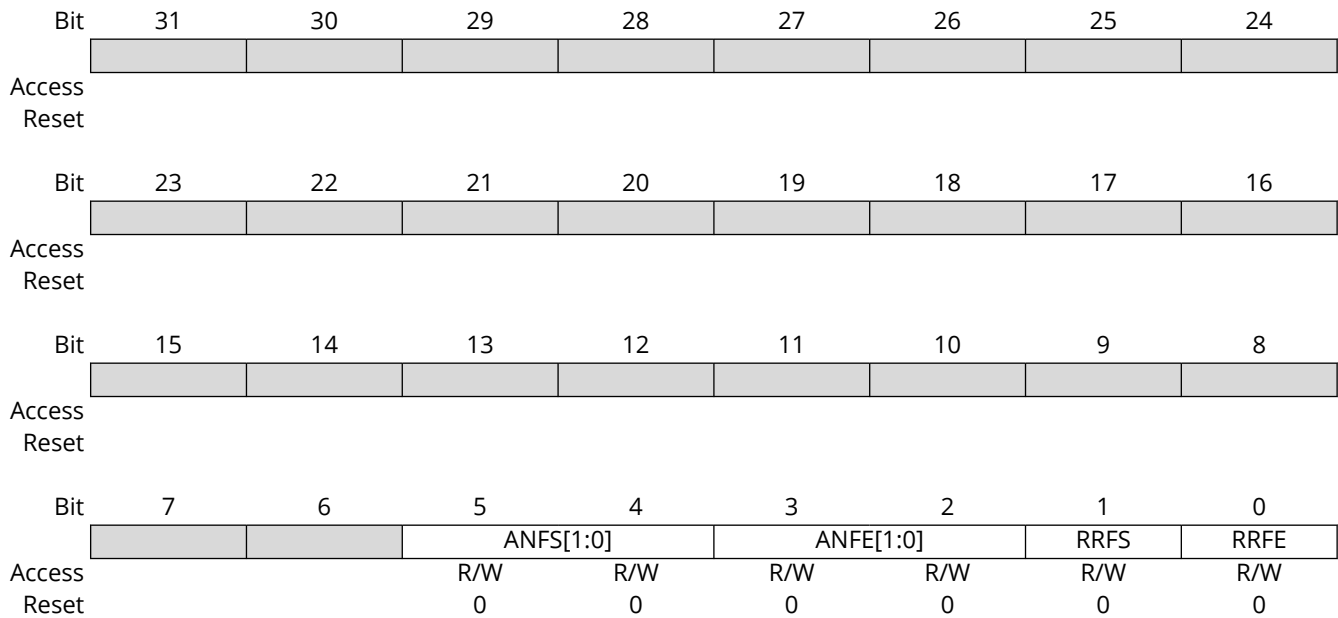
Value	Description
0	CAN interrupt line n disabled.
1	CAN interrupt line n enabled.



### 38.8.20 Global Filter Configuration

**Name:** GFC  
**Offset:** 0x80  
**Reset:** 0x00000000  
**Property:** Write-restricted

This register is write-restricted and only writable if bit fields CCCR.CCE = 1 and CCCR.INIT = 1.



#### Bits 5:4 – ANFS[1:0] Accept Non-matching Frames Standard

Defines how received messages with 11-bit IDs that do not match any element of the filter list are treated.

Value	Name	Description
0x0	RXF0	Accept in Rx FIFO 0.
0x1	RXF1	Accept in Rx FIFO 1.
0x2 or 0x3	REJECT	Reject

#### Bits 3:2 – ANFE[1:0] Accept Non-matching Frames Extended

Defines how received messages with 29-bit IDs that do not match any element of the filter list are treated.

Value	Name	Description
0x0	RXF0	Accept in Rx FIFO 0.
0x1	RXF1	Accept in Rx FIFO 1.
0x2 or 0x3	REJECT	Reject

#### Bit 1 – RRFS Reject Remote Frames Standard

Value	Description
0	Filter remote frames with 11-bit standard IDs.
1	Reject all remote frames with 11-bit standard IDs.

#### Bit 0 – RRFE Reject Remote Frames Extended

Value	Description
0	Filter remote frames with 29-bit extended IDs.

Value	Description
1	Reject all remote frames with 29-bit extended IDS.

### 38.8.21 Standard ID Filter Configuration

**Name:** SIDFC  
**Offset:** 0x84  
**Reset:** 0x00000000  
**Property:** Write-restricted

This register is write-restricted and only writable if bit fields CCCR.CCE = 1 and CCCR.INIT = 1.

Bit	31	30	29	28	27	26	25	24
Access								
Reset								
Bit	23	22	21	20	19	18	17	16
	LSS[7:0]							
Access	R/W	R/W	R/W	R/W	R/W	R/W	R/W	R/W
Reset	0	0	0	0	0	0	0	0
Bit	15	14	13	12	11	10	9	8
	FLSSA[15:8]							
Access	R/W	R/W	R/W	R/W	R/W	R/W	R/W	R/W
Reset	0	0	0	0	0	0	0	0
Bit	7	6	5	4	3	2	1	0
	FLSSA[7:0]							
Access	R/W	R/W	R/W	R/W	R/W	R/W	R/W	R/W
Reset	0	0	0	0	0	0	0	0

#### Bits 23:16 – LSS[7:0] List Size Standard

Value	Description
0	No standard Message ID filter.
1 - 128	Number of standard Message ID filter elements.
> 128	Values greater than 128 are interpreted as 128.

#### Bits 15:0 – FLSSA[15:0] Filter List Standard Start Address

Start address of standard Message ID filter list. When the CAN module addresses the Message RAM it addresses 32-bit words, not single bytes. The configurable start addresses are 32-bit word addresses, i.e. only bits 15 to 2 are evaluated, the two least significant bits are ignored. Bits 1 to 0 will always be read back as “00”.

### 38.8.22 Extended ID Filter Configuration

**Name:** XIDFC  
**Offset:** 0x88  
**Reset:** 0x00000000  
**Property:** Write-restricted

Bit	31	30	29	28	27	26	25	24
Access								
Reset								
Bit	23	22	21	20	19	18	17	16
	LSE[6:0]							
Access		R/W	R/W	R/W	R/W	R/W	R/W	R/W
Reset		0	0	0	0	0	0	0
Bit	15	14	13	12	11	10	9	8
	FLESA[15:8]							
Access	R/W	R/W	R/W	R/W	R/W	R/W	R/W	R/W
Reset	0	0	0	0	0	0	0	0
Bit	7	6	5	4	3	2	1	0
	FLESA[7:0]							
Access	R/W	R/W	R/W	R/W	R/W	R/W	R/W	R/W
Reset	0	0	0	0	0	0	0	0

#### Bits 22:16 – LSE[6:0] List Size Extended

Value	Description
0	No extended Message ID filter.
1 – 64	Number of Extended Message ID filter elements.
> 64	Values greater than 64 are interpreted as 64.

#### Bits 15:0 – FLESA[15:0] Filter List Extended Start Address

Start address of extended Message ID filter list. When the CAN module addresses the Message RAM it addresses 32-bit words, not single bytes. The configurable start addresses are 32-bit word addresses, i.e. only bits 15 to 2 are evaluated, the two least significant bits are ignored. Bits 1 to 0 will always be read back as “00”.

### 38.8.23 Extended ID AND Mask

**Name:** XIDAM  
**Offset:** 0x90  
**Reset:** 0x1FFFFFFF  
**Property:** Write-restricted

This register is write-restricted and only writable if bit fields CCCR.CCE = 1 and CCCR.INIT = 1.

Bit	31	30	29	28	27	26	25	24
				EIDM[28:24]				
Access				R/W	R/W	R/W	R/W	R/W
Reset				1	1	1	1	1
Bit	23	22	21	20	19	18	17	16
	EIDM[23:16]							
Access	R/W	R/W	R/W	R/W	R/W	R/W	R/W	R/W
Reset	1	1	1	1	1	1	1	1
Bit	15	14	13	12	11	10	9	8
	EIDM[15:8]							
Access	R/W	R/W	R/W	R/W	R/W	R/W	R/W	R/W
Reset	1	1	1	1	1	1	1	1
Bit	7	6	5	4	3	2	1	0
	EIDM[7:0]							
Access	R/W	R/W	R/W	R/W	R/W	R/W	R/W	R/W
Reset	1	1	1	1	1	1	1	1

#### Bits 28:0 – EIDM[28:0] Extended ID Mask

For acceptance filtering of extended frames the Extended ID AND Mask is ANDed with the Message ID of a received frame. Intended for masking of 29-bit IDs in SAE J1939. With the reset value of all bits set to one the mask is not active.

### 38.8.24 High Priority Message Status

**Name:** HPMS  
**Offset:** 0x94  
**Reset:** 0x00000000  
**Property:** Read-only

This register is updated every time a Message ID filter element configured to generate a priority event matches. This can be used to monitor the status of incoming high priority messages and to enable fast access to these messages.

Bit	31	30	29	28	27	26	25	24
Access								
Reset								
Bit	23	22	21	20	19	18	17	16
Access								
Reset								
Bit	15	14	13	12	11	10	9	8
Access	FLST	FIDX[6:0]						
Reset	R	R	R	R	R	R	R	R
Reset	0	0	0	0	0	0	0	0
Bit	7	6	5	4	3	2	1	0
Access	MSI[1:0]		BIDX[5:0]					
Reset	R	R	R	R	R	R	R	R
Reset	0	0	0	0	0	0	0	0

#### Bit 15 – FLST Filter List

Indicates the filter list of the matching filter element.

Value	Description
0	Standard Filter List.
1	Extended Filter List.

#### Bits 14:8 – FIDX[6:0] Filter Index

Index of matching filter element. Range is 0 to SIDFC.LSS - 1 (standard) or XIDFC.LSE - 1 (extended).

#### Bits 7:6 – MSI[1:0] Message Storage Indicator

This field defines the message storage information to a FIFO.

Value	Name	Description
0x0	NONE	No FIFO selected.
0x1	LOST	FIFO message lost.
0x2	FIFO0	Message stored in FIFO 0.
0x3	FIFO1	Message stored in FIFO 1.

#### Bits 5:0 – BIDX[5:0] Buffer Index

Index of Rx FIFO element to which the message was stored. Only valid when MSI[1] = 1.

### 38.8.25 New Data 1

**Name:** NDAT1  
**Offset:** 0x98  
**Reset:** 0x00000000  
**Property:** -

Bit	31	30	29	28	27	26	25	24
	ND31	ND30	ND29	ND28	ND27	ND26	ND25	ND24
Access	R/W	R/W	R/W	R/W	R/W	R/W	R/W	R/W
Reset	0	0	0	0	0	0	0	0
Bit	23	22	21	20	19	18	17	16
	ND23	ND22	ND21	ND20	ND19	ND18	ND17	ND16
Access	R/W	R/W	R/W	R/W	R/W	R/W	R/W	R/W
Reset	0	0	0	0	0	0	0	0
Bit	15	14	13	12	11	10	9	8
	ND15	ND14	ND13	ND12	ND11	ND10	ND9	ND8
Access	R/W	R/W	R/W	R/W	R/W	R/W	R/W	R/W
Reset	0	0	0	0	0	0	0	0
Bit	7	6	5	4	3	2	1	0
	ND7	ND6	ND5	ND4	ND3	ND2	ND1	ND0
Access	R/W	R/W	R/W	R/W	R/W	R/W	R/W	R/W
Reset	0	0	0	0	0	0	0	0

#### Bits 0, 1, 2, 3, 4, 5, 6, 7, 8, 9, 10, 11, 12, 13, 14, 15, 16, 17, 18, 19, 20, 21, 22, 23, 24, 25, 26, 27, 28, 29, 30, 31 - NDn New Data n [n = 0..31]

The register holds the New Data flags of Rx Buffers 0 to 31. The flags are set when the respective Rx Buffer has been updated from a received frame. The flags remain set until the Host clears them. A flag is cleared by writing 1 to the corresponding bit position. Writing a 0 has no effect. A hard reset will clear the register.

### 38.8.26 New Data 2

**Name:** NDAT2  
**Offset:** 0x9C  
**Reset:** 0x00000000  
**Property:** -

Bit	31	30	29	28	27	26	25	24
	ND63	ND62	ND61	ND60	ND59	ND58	ND57	ND56
Access	R/W	R/W	R/W	R/W	R/W	R/W	R/W	R/W
Reset	0	0	0	0	0	0	0	0
Bit	23	22	21	20	19	18	17	16
	ND55	ND54	ND53	ND52	ND51	ND50	ND49	ND48
Access	R/W	R/W	R/W	R/W	R/W	R/W	R/W	R/W
Reset	0	0	0	0	0	0	0	0
Bit	15	14	13	12	11	10	9	8
	ND47	ND46	ND45	ND44	ND43	ND42	ND41	ND40
Access	R/W	R/W	R/W	R/W	R/W	R/W	R/W	R/W
Reset	0	0	0	0	0	0	0	0
Bit	7	6	5	4	3	2	1	0
	ND39	ND38	ND37	ND36	ND35	ND34	ND33	ND32
Access	R/W	R/W	R/W	R/W	R/W	R/W	R/W	R/W
Reset	0	0	0	0	0	0	0	0

#### Bits 0, 1, 2, 3, 4, 5, 6, 7, 8, 9, 10, 11, 12, 13, 14, 15, 16, 17, 18, 19, 20, 21, 22, 23, 24, 25, 26, 27, 28, 29, 30, 31 - NDn New Data [n = 32..64]

The register holds the New Data flags of Rx Buffers 32 to 63. The flags are set when the respective Rx Buffer has been updated from a received frame. The flags remain set until the Host clears them. A flag is cleared by writing 1 to the corresponding bit position. Writing a 0 has no effect. A hard reset will clear the register.



### 38.8.27 Rx FIFO 0 Configuration

**Name:** RXFOC  
**Offset:** 0xA0  
**Reset:** 0x00000000  
**Property:** Write-restricted

Bit	31	30	29	28	27	26	25	24
	FOOM		FOWM[6:0]					
Access	R/W	R/W	R/W	R/W	R/W	R/W	R/W	R/W
Reset	0	0	0	0	0	0	0	0
Bit	23	22	21	20	19	18	17	16
		FOS[6:0]						
Access		R/W	R/W	R/W	R/W	R/W	R/W	R/W
Reset		0	0	0	0	0	0	0
Bit	15	14	13	12	11	10	9	8
	FOSA[15:8]							
Access	R/W	R/W	R/W	R/W	R/W	R/W	R/W	R/W
Reset	0	0	0	0	0	0	0	0
Bit	7	6	5	4	3	2	1	0
	FOSA[7:0]							
Access	R/W	R/W	R/W	R/W	R/W	R/W	R/W	R/W
Reset	0	0	0	0	0	0	0	0

#### Bit 31 – FOOM FIFO 0 Operation Mode

FIFO 0 can be operated in blocking or in overwrite mode.

Value	Description
0	FIFO 0 blocking mode.
1	FIFO 0 overwrite mode.

#### Bits 30:24 – FOWM[6:0] Rx FIFO 0 Watermark

Value	Description
0	Watermark interrupt disabled.
1 – 64	Level for Rx FIFO 0 watermark interrupt (IR.RFOW).
>64	Watermark interrupt disabled.

#### Bits 22:16 – FOS[6:0] Rx FIFO 0 Size

The Rx FIFO 0 elements are indexed from 0 to FOS - 1.

Value	Description
0	No Rx FIFO 0
1 – 64	Number of Rx FIFO 0 elements.
>64	Values greater than 64 are interpreted as 64.

#### Bits 15:0 – FOSA[15:0] Rx FIFO 0 Start Address

Start address of Rx FIFO 0 in Message RAM. When the CAN module addresses the Message RAM it addresses 32-bit words, not single bytes. The configurable start addresses are 32-bit word addresses, i.e. only bits 15 to 2 are evaluated, the two least significant bits are ignored. Bits 1 to 0 will always be read back as "00".

### 38.8.28 Rx FIFO 0 Status

**Name:** RXFOS  
**Offset:** 0xA4  
**Reset:** 0x00000000  
**Property:** Read-only

Bit	31	30	29	28	27	26	25	24
							RFOL	FOF
Access							R	R
Reset							0	0
Bit	23	22	21	20	19	18	17	16
			FOPI[5:0]					
Access			R	R	R	R	R	R
Reset			0	0	0	0	0	0
Bit	15	14	13	12	11	10	9	8
			FOGI[5:0]					
Access			R	R	R	R	R	R
Reset			0	0	0	0	0	0
Bit	7	6	5	4	3	2	1	0
	FOFL[6:0]							
Access		R	R	R	R	R	R	R
Reset		0	0	0	0	0	0	0

#### Bit 25 – RFOL Rx FIFO 0 Message Lost

This bit is a copy of interrupt flag IR.RFOL. When IR.RFOL is reset, this bit is also reset. Overwriting the oldest message when RXF0C.FOOM = '1' will not set this flag.

Value	Description
0	No Rx FIFO 0 message lost.
1	Rx FIFO 0 message lost, also set after write attempt to Rx FIFO 0 of size zero.

#### Bit 24 – FOF Rx FIFO 0 Full

Value	Description
0	Rx FIFO 0 not full.
1	Rx FIFO 0 full.

#### Bits 21:16 – FOPI[5:0] Rx FIFO 0 Put Index

Rx FIFO 0 write index pointer, range 0 to 63.

#### Bits 13:8 – FOGI[5:0] Rx FIFO 0 Get Index

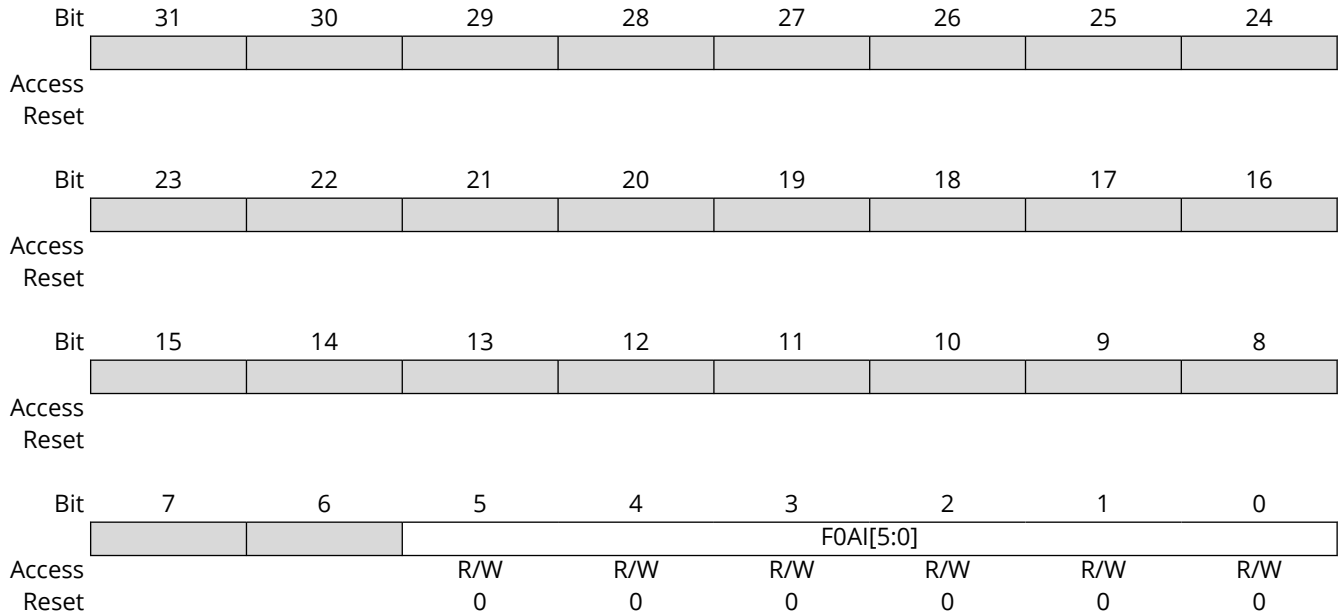
Rx FIFO 0 read index pointer, range 0 to 63.

#### Bits 6:0 – FOFL[6:0] Rx FIFO 0 Fill Level

Number of elements stored in Rx FIFO 0, range 0 to 64.

### 38.8.29 Rx FIFO 0 Acknowledge

**Name:** RXFOA  
**Offset:** 0xA8  
**Reset:** 0x00000000  
**Property:** -



#### Bits 5:0 – F0AI[5:0] Rx FIFO 0 Acknowledge Index

After the Host has read a message or a sequence of messages from Rx FIFO 0 it has to write the buffer index of the last element read from Rx FIFO 0 to F0AI. This will set the Rx FIFO 0 Get Index RXF0S.F0GI to F0AI + 1 and update the FIFO 0 Fill Level RXF0S.F0FL.

### 38.8.30 Rx Buffer Configuration

**Name:** RXBC  
**Offset:** 0xAC  
**Reset:** 0x00000000  
**Property:** Write-restricted

This register is write-restricted and only writable if bit fields CCCR.CCE = 1 and CCCR.INIT = 1.

Bit	31	30	29	28	27	26	25	24
	[Greyed out bits]							
Access								
Reset								
Bit	23	22	21	20	19	18	17	16
	[Greyed out bits]							
Access								
Reset								
Bit	15	14	13	12	11	10	9	8
	RBSA[15:8]							
Access	R/W	R/W	R/W	R/W	R/W	R/W	R/W	R/W
Reset	0	0	0	0	0	0	0	0
Bit	7	6	5	4	3	2	1	0
	RBSA[7:0]							
Access	R/W	R/W	R/W	R/W	R/W	R/W	R/W	R/W
Reset	0	0	0	0	0	0	0	0

#### Bits 15:0 – RBSA[15:0] Rx Buffer Start Address

Configures the start address of the Rx Buffers section in the Message RAM. Also used to reference debug message A,B,C. When the CAN module addresses the Message RAM it addresses 32-bit words, not single bytes. The configurable start addresses are 32-bit word addresses, i.e. only bits 15 to 2 are evaluated, the two least significant bits are ignored. Bits 1 to 0 will always be read back as “00”.

### 38.8.31 Rx FIFO 1 Configuration

**Name:** RXF1C  
**Offset:** 0xB0  
**Reset:** 0x00000000  
**Property:** Write-restricted

This register is write-restricted and only writable if bit fields CCCR.CCE = 1 and CCCR.INIT = 1.

Bit	31	30	29	28	27	26	25	24
	F1OM		F1WM[6:0]					
Access	R/W	R/W	R/W	R/W	R/W	R/W	R/W	R/W
Reset	0	0	0	0	0	0	0	0
Bit	23	22	21	20	19	18	17	16
		F1S[6:0]						
Access		R/W	R/W	R/W	R/W	R/W	R/W	R/W
Reset		0	0	0	0	0	0	0
Bit	15	14	13	12	11	10	9	8
	F1SA[15:8]							
Access	R/W	R/W	R/W	R/W	R/W	R/W	R/W	R/W
Reset	0	0	0	0	0	0	0	0
Bit	7	6	5	4	3	2	1	0
	F1SA[7:0]							
Access	R/W	R/W	R/W	R/W	R/W	R/W	R/W	R/W
Reset	0	0	0	0	0	0	0	0

#### Bit 31 – F1OM FIFO 1 Operation Mode

FIFO 1 can be operated in blocking or in overwrite mode.

Value	Description
0	FIFO 1 blocking mode.
1	FIFO 1 overwrite mode.

#### Bits 30:24 – F1WM[6:0] Rx FIFO 1 Watermark

Value	Description
0	Watermark interrupt disabled.
1 – 64	Level for Rx FIFO 1 watermark interrupt (IR.RF1W).
>64	Watermark interrupt disabled.

#### Bits 22:16 – F1S[6:0] Rx FIFO 1 Size

The Rx FIFO 1 elements are indexed from 0 to F1S - 1.

Value	Description
0	No Rx FIFO 1
1 – 64	Number of Rx FIFO 1 elements.
>64	Values greater than 64 are interpreted as 64.

#### Bits 15:0 – F1SA[15:0] Rx FIFO 1 Start Address

Start address of Rx FIFO 1 in Message RAM. When the CAN module addresses the Message RAM it addresses 32-bit words, not single bytes. The configurable start addresses are 32-bit word addresses, i.e. only bits 15 to 2 are evaluated, the two least significant bits are ignored. Bits 1 to 0 will always be read back as "00".

### 38.8.32 Rx FIFO 1 Status

**Name:** RXF1S  
**Offset:** 0xB4  
**Reset:** 0x00000000  
**Property:** Read-only

Bit	31	30	29	28	27	26	25	24
	DMS[1:0]						RF1L	F1F
Access	R	R					R	R
Reset	0	0					0	0
Bit	23	22	21	20	19	18	17	16
			F1PI[5:0]					
Access			R	R	R	R	R	R
Reset			0	0	0	0	0	0
Bit	15	14	13	12	11	10	9	8
			F1GI[5:0]					
Access			R	R	R	R	R	R
Reset			0	0	0	0	0	0
Bit	7	6	5	4	3	2	1	0
		F1FL[6:0]						
Access		R	R	R	R	R	R	R
Reset		0	0	0	0	0	0	0

**Bits 31:30 – DMS[1:0]** Debug Message Status  
This field defines the debug message status.

Value	Name	Description
0x0	IDLE	Idle state, wait for reception of debug messages, DMA request is cleared.
0x1	DBGA	Debug message A received.
0x2	DBGB	Debug message A, B received.
0x3	DBGC	Debug message A, B, C received, DMA request is set.

**Bit 25 – RF1L** Rx FIFO 1 Message Lost  
This bit is a copy of interrupt flag IR.RF1L. When IR.RF1L is reset, this bit is also reset. Overwriting the oldest message when RXF1C.F1OM = '1' will not set this flag.

Value	Description
0	No Rx FIFO 1 message lost.
1	Rx FIFO 1 message lost, also set after write attempt to Rx FIFO 1 of size zero.

**Bit 24 – F1F** Rx FIFO 1 Full

Value	Description
0	Rx FIFO 1 not full.
1	Rx FIFO 1 full.

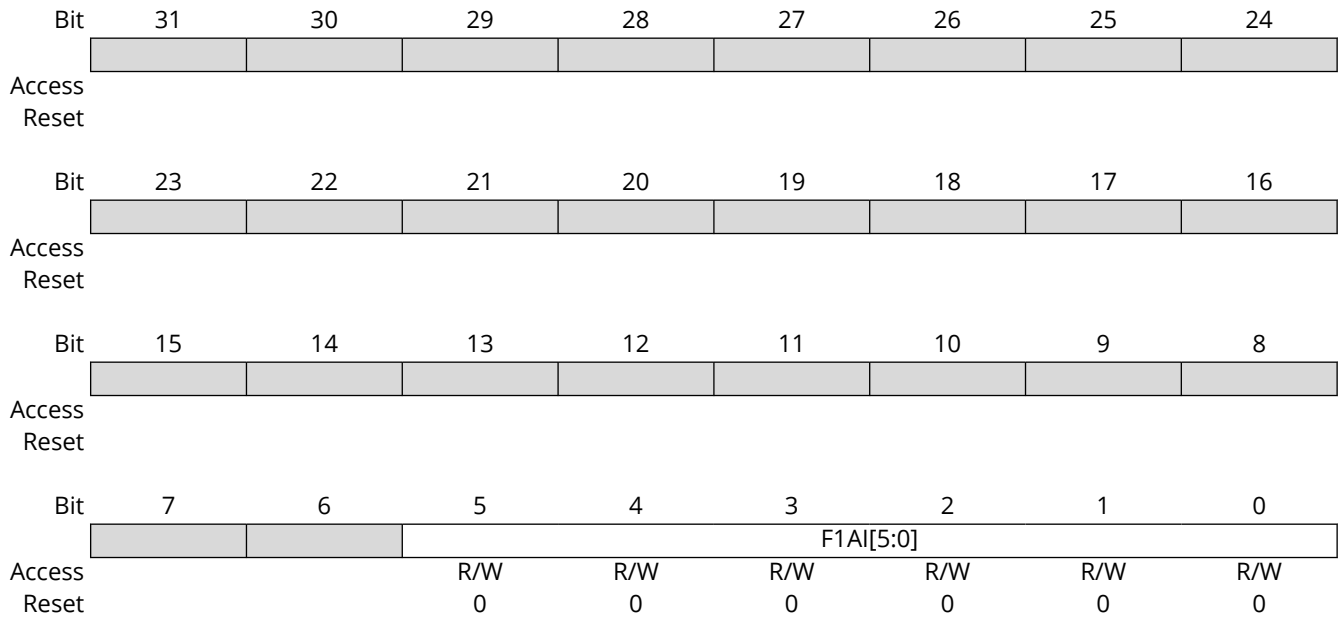
**Bits 21:16 – F1PI[5:0]** Rx FIFO 1 Put Index  
Rx FIFO 1 write index pointer, range 0 to 63.

**Bits 13:8 – F1GI[5:0]** Rx FIFO 1 Get Index  
Rx FIFO 1 read index pointer, range 0 to 63.

**Bits 6:0 – F1FL[6:0]** Rx FIFO 1 Fill Level  
Number of elements stored in Rx FIFO 1, range 0 to 64.

### 38.8.33 Rx FIFO 1 Acknowledge

**Name:** RXF1A  
**Offset:** 0xB8  
**Reset:** 0x00000000  
**Property:** -



#### Bits 5:0 – F1AI[5:0] Rx FIFO 1 Acknowledge Index

After the Host has read a message or a sequence of messages from Rx FIFO 1 it has to write the buffer index of the last element read from Rx FIFO 1 to F1AI. This will set the Rx FIFO 1 Get Index RXF1S.F1GI to F1AI + 1 and update the FIFO 1 Fill Level RXF1S.F1FL.

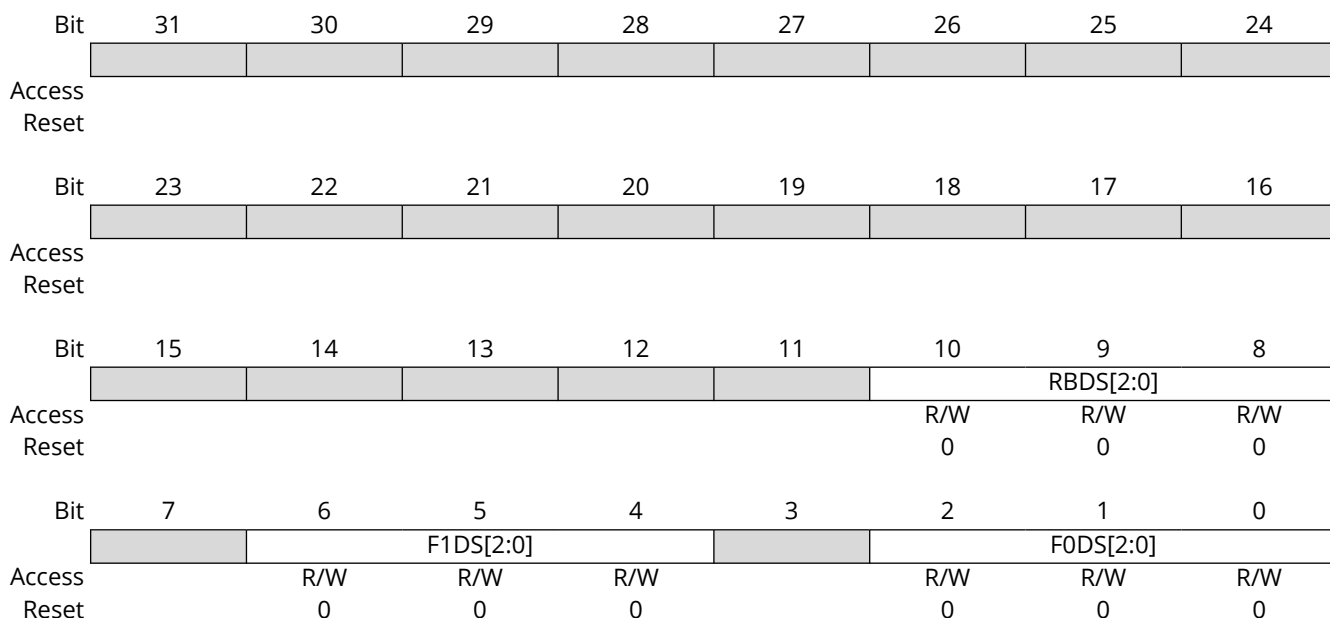


### 38.8.34 Rx Buffer / FIFO Element Size Configuration

**Name:** RXESC  
**Offset:** 0xBC  
**Reset:** 0x00000000  
**Property:** Write-restricted

This register is write-restricted and only writable if bit fields CCCR.CCE = 1 and CCCR.INIT = 1.

Configures the number of data bytes belonging to an Rx Buffer / Rx FIFO element. Data field sizes >8 bytes are intended for CAN FD operation only.



#### Bits 10:8 – RBDS[2:0] Rx Buffer Data Field Size

In case the data field size of an accepted CAN frame exceeds the data field size configured for the matching Rx Buffer, only the number of bytes as configured by RXESC are stored to the Rx Buffer element. The rest of the frame's data field is ignored.

Value	Name	Description
0x0	DATA8	8 byte data field.
0x1	DATA12	12 byte data field.
0x2	DATA16	16 byte data field.
0x3	DATA20	20 byte data field.
0x4	DATA24	24 byte data field.
0x5	DATA32	32 byte data field.
0x6	DATA48	48 byte data field.
0x7	DATA64	64 byte data field.

#### Bits 6:4 – F1DS[2:0] Rx FIFO 1 Data Field Size

In case the data field size of an accepted CAN frame exceeds the data field size configured for the matching Rx FIFO 1, only the number of bytes as configured by RXESC are stored to the Rx FIFO 1 element. The rest of the frame's data field is ignored.

Value	Name	Description
0x0	DATA8	8 byte data field.
0x1	DATA12	12 byte data field.
0x2	DATA16	16 byte data field.
0x3	DATA20	20 byte data field.

Value	Name	Description
0x4	DATA24	24 byte data field.
0x5	DATA32	32 byte data field.
0x6	DATA48	48 byte data field.
0x7	DATA64	64 byte data field.

**Bits 2:0 – FODS[2:0]** Rx FIFO 0 Data Field Size

In case the data field size of an accepted CAN frame exceeds the data field size configured for the matching Rx FIFO 0, only the number of bytes as configured by RXESC are stored to the Rx FIFO 0 element. The rest of the frame's data field is ignored.

Value	Name	Description
0x0	DATA8	8 byte data field.
0x1	DATA12	12 byte data field.
0x2	DATA16	16 byte data field.
0x3	DATA20	20 byte data field.
0x4	DATA24	24 byte data field.
0x5	DATA32	32 byte data field.
0x6	DATA48	48 byte data field.
0x7	DATA64	64 byte data field.

### 38.8.35 Tx Buffer Configuration

**Name:** TXBC  
**Offset:** 0xC0  
**Reset:** 0x00000000  
**Property:** Write-restricted

This register is write-restricted and only writable if bit fields CCCR.CCE = 1 and CCCR.INIT = 1.

**Note:** Be aware that the sum of TFQS and NDTB may not be greater than 32. There is no check for erroneous configurations. The Tx Buffers section in the Message RAM starts with the dedicated Tx Buffers.

Bit	31	30	29	28	27	26	25	24
	TFQM		TFQS[5:0]					
Access	R/W		R/W	R/W	R/W	R/W	R/W	R/W
Reset	0		0	0	0	0	0	0
Bit	23	22	21	20	19	18	17	16
			NDTB[5:0]					
Access			R/W	R/W	R/W	R/W	R/W	R/W
Reset			0	0	0	0	0	0
Bit	15	14	13	12	11	10	9	8
	TBSA[15:8]							
Access	R/W	R/W	R/W	R/W	R/W	R/W	R/W	R/W
Reset	0	0	0	0	0	0	0	0
Bit	7	6	5	4	3	2	1	0
	TBSA[7:0]							
Access	R/W	R/W	R/W	R/W	R/W	R/W	R/W	R/W
Reset	0	0	0	0	0	0	0	0

#### Bit 30 – TFQM Tx FIFO/Queue Mode

Value	Description
0	Tx FIFO operation.
1	Tx Queue operation.

#### Bits 29:24 – TFQS[5:0] Transmit FIFO/Queue Size

Value	Description
0	No Tx FIFO/Queue.
1 – 32	Number of Tx Buffers used for Tx FIFO/Queue.
>32	Values greater than 32 are interpreted as 32.

#### Bits 21:16 – NDTB[5:0] Number of Dedicated Transmit Buffers

Value	Description
0	No Tx FIFO/Queue.
1 – 32	Number of Tx Buffers used for Tx FIFO/Queue.
>32	Values greater than 32 are interpreted as 32.

#### Bits 15:0 – TBSA[15:0] Tx Buffers Start Address

Start address of Tx Buffers section in Message RAM. When the CAN module addresses the Message RAM it addresses 32-bit words, not single bytes. The configurable start addresses are 32-bit word addresses, i.e. only bits 15 to 2 are evaluated, the two least significant bits are ignored. Bits 1 to 0 will always be read back as "00".

### 38.8.36 Tx FIFO/Queue Status

**Name:** TXFQS  
**Offset:** 0xC4  
**Reset:** 0x00000000  
**Property:** Read-only

**Note:** In case of mixed configurations where dedicated Tx Buffers are combined with a Tx FIFO or a Tx Queue, the Put and Get Indexes indicate the number of the Tx Buffer starting with the first dedicated Tx Buffers. Example: For a configuration of 12 dedicated Tx Buffers and a Tx FIFO of 20 Buffers a Put Index of 15 points to the fourth buffer of the Tx FIFO.

Bit	31	30	29	28	27	26	25	24
Access								
Reset								
Bit	23	22	21	20	19	18	17	16
Access			TFQF	TFQPI[4:0]				
Reset			R	R	R	R	R	R
Reset			0	0	0	0	0	0
Bit	15	14	13	12	11	10	9	8
Access				TFGI[4:0]				
Reset				R	R	R	R	R
Reset				0	0	0	0	0
Bit	7	6	5	4	3	2	1	0
Access			TFFL[5:0]					
Reset			R	R	R	R	R	R
Reset			0	0	0	0	0	0

#### Bit 21 – TFQF Tx FIFO/Queue Full

Value	Description
0	Tx FIFO/Queue not full.
1	Tx FIFO/Queue full.

**Bits 20:16 – TFQPI[4:0]** Tx FIFO/Queue Put Index  
Tx FIFO/Queue write index pointer, range 0 to 31.

**Bits 12:8 – TFGI[4:0]** Tx FIFO/Queue Get Index  
Tx FIFO read index pointer, range 0 to 31. Read as zero when Tx Queue operation is configured (TXBC.TFQM = '1').

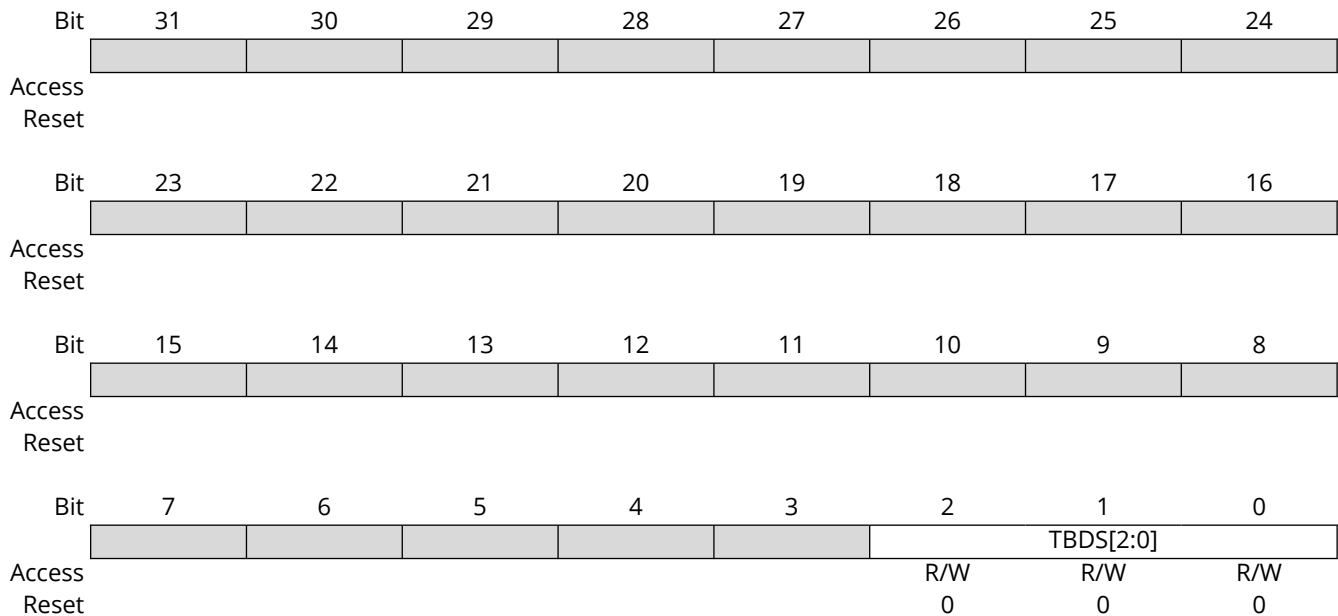
**Bits 5:0 – TFFL[5:0]** Tx FIFO Free Level  
Number of consecutive free Tx FIFO elements starting from TFGI, range 0 to 32. Read as zero when Tx Queue operation is configured (TXBC.TFQM = '1').

### 38.8.37 Tx Buffer Element Size Configuration

**Name:** TXESC  
**Offset:** 0xC8  
**Reset:** 0x00000000  
**Property:** Write-restricted

This register is write-restricted and only writable if bit fields CCCR.CCE = 1 and CCCR.INIT = 1.

Configures the number of data bytes belonging to a Tx Buffer element. Data field sizes >8 bytes are intended for CAN FD operation only.



#### Bits 2:0 – TBDS[2:0] Tx Buffer Data Field Size

In case the data length code DLC of a Tx Buffer element is configured to a value higher than the Tx Buffer data field size TXESC.TBDS, the bytes not defined by the Tx Buffer are transmitted as “0xCC” (padding bytes).

Value	Name	Description
0x0	DATA8	8 byte data field.
0x1	DATA12	12 byte data field.
0x2	DATA16	16 byte data field.
0x3	DATA20	20 byte data field.
0x4	DATA24	24 byte data field.
0x5	DATA32	32 byte data field.
0x6	DATA48	48 byte data field.
0x7	DATA64	64 byte data field.

### 38.8.38 Tx Buffer Request Pending

**Name:** TXBRP  
**Offset:** 0xCC  
**Reset:** 0x00000000  
**Property:** Read-only

**Note:** TXBRP bits which are set while a Tx scan is in progress are not considered during this particular Tx scan. In case a cancellation is requested for such a Tx Buffer, this Add Request is canceled immediately, the corresponding TXBRP bit is reset.

Bit	31	30	29	28	27	26	25	24
	TRP31	TRP30	TRP29	TRP28	TRP27	TRP26	TRP25	TRP24
Access	R	R	R	R	R	R	R	R
Reset	0	0	0	0	0	0	0	0
Bit	23	22	21	20	19	18	17	16
	TRP23	TRP22	TRP21	TRP20	TRP19	TRP18	TRP17	TRP16
Access	R	R	R	R	R	R	R	R
Reset	0	0	0	0	0	0	0	0
Bit	15	14	13	12	11	10	9	8
	TRP15	TRP14	TRP13	TRP12	TRP11	TRP10	TRP9	TRP8
Access	R	R	R	R	R	R	R	R
Reset	0	0	0	0	0	0	0	0
Bit	7	6	5	4	3	2	1	0
	TRP7	TRP6	TRP5	TRP4	TRP3	TRP2	TRP1	TRP0
Access	R	R	R	R	R	R	R	R
Reset	0	0	0	0	0	0	0	0

#### Bits 0, 1, 2, 3, 4, 5, 6, 7, 8, 9, 10, 11, 12, 13, 14, 15, 16, 17, 18, 19, 20, 21, 22, 23, 24, 25, 26, 27, 28, 29, 30, 31 – TRPn Transmission Request Pending

Each Tx Buffer has its own Transmission Request Pending bit.

The bits are reset after a requested transmission has completed or has been cancelled via register TXBCR.

TXBRP bits are set only for those Tx Buffers configured via TXBC. After a TXBRP bit has been set, a Tx scan is started to check for the pending Tx request with the highest priority (Tx Buffer with lowest Message ID).

A cancellation request resets the corresponding transmission request pending bit of register TXBRP. In case a transmission has already been started when a cancellation is requested, this is done at the end of the transmission, regardless whether the transmission was successful or not. The cancellation request bits are reset directly after the corresponding TXBRP bit has been reset.

After a cancellation has been requested, a finished cancellation is signaled via TXBCF

- after successful transmission together with the corresponding TXBTO bit
- when the transmission has not yet been started at the point of cancellation
- when the transmission has been aborted due to lost arbitration
- when an error occurred during frame transmission

In DAR mode all transmissions are automatically canceled if they are not successful. The corresponding TXBCF bit is set for all unsuccessful transmissions.

Value	Description
0	No transmission request pending.
1	Transmission request pending.

### 38.8.39 Tx Buffer Add Request

**Name:** TXBAR  
**Offset:** 0xD0  
**Reset:** 0x00000000  
**Property:** -

**Note:** If an add request is applied for a Tx Buffer with pending transmission request (corresponding TXBRP bit is already set), this add request is ignored.

Bit	31	30	29	28	27	26	25	24
	AR31	AR30	AR29	AR28	AR27	AR26	AR25	AR24
Access	R/W	R/W	R/W	R/W	R/W	R/W	R/W	R/W
Reset	0	0	0	0	0	0	0	0
Bit	23	22	21	20	19	18	17	16
	AR23	AR22	AR21	AR20	AR19	AR18	AR17	AR16
Access	R/W	R/W	R/W	R/W	R/W	R/W	R/W	R/W
Reset	0	0	0	0	0	0	0	0
Bit	15	14	13	12	11	10	9	8
	AR15	AR14	AR13	AR12	AR11	AR10	AR9	AR8
Access	R/W	R/W	R/W	R/W	R/W	R/W	R/W	R/W
Reset	0	0	0	0	0	0	0	0
Bit	7	6	5	4	3	2	1	0
	AR7	AR6	AR5	AR4	AR3	AR2	AR1	AR0
Access	R/W	R/W	R/W	R/W	R/W	R/W	R/W	R/W
Reset	0	0	0	0	0	0	0	0

#### Bits 0, 1, 2, 3, 4, 5, 6, 7, 8, 9, 10, 11, 12, 13, 14, 15, 16, 17, 18, 19, 20, 21, 22, 23, 24, 25, 26, 27, 28, 29, 30, 31 – ARn Add Request

Each Tx Buffer has its own Add Request bit.

Writing a '1' will set the corresponding Add Request bit; writing a '0' has no impact. This enables the Host to set transmission requests for multiple Tx Buffers with one write to TXBAR. TXBAR bits are set only for those Tx Buffers configured via TXBC. When no Tx scan is running, the bits are reset immediately, else the bits remain set until the Tx scan process has completed.

### 38.8.40 Tx Buffer Cancellation Request

**Name:** TXBCR  
**Offset:** 0xD4  
**Reset:** 0x00000000  
**Property:** -

Bit	31	30	29	28	27	26	25	24
	CR31	CR30	CR29	CR28	CR27	CR26	CR25	CR24
Access	R/W	R/W	R/W	R/W	R/W	R/W	R/W	R/W
Reset	0	0	0	0	0	0	0	0
Bit	23	22	21	20	19	18	17	16
	CR23	CR22	CR21	CR20	CR19	CR18	CR17	CR16
Access	R/W	R/W	R/W	R/W	R/W	R/W	R/W	R/W
Reset	0	0	0	0	0	0	0	0
Bit	15	14	13	12	11	10	9	8
	CR15	CR14	CR13	CR12	CR11	CR10	CR9	CR8
Access	R/W	R/W	R/W	R/W	R/W	R/W	R/W	R/W
Reset	0	0	0	0	0	0	0	0
Bit	7	6	5	4	3	2	1	0
	CR7	CR6	CR5	CR4	CR3	CR2	CR1	CR0
Access	R/W	R/W	R/W	R/W	R/W	R/W	R/W	R/W
Reset	0	0	0	0	0	0	0	0

#### Bits 0, 1, 2, 3, 4, 5, 6, 7, 8, 9, 10, 11, 12, 13, 14, 15, 16, 17, 18, 19, 20, 21, 22, 23, 24, 25, 26, 27, 28, 29, 30, 31 – CRn Cancellation Request

Each Tx Buffer has its own Cancellation Request bit.

Writing a '1' will set the corresponding Cancellation Request bit; writing a '0' has no impact. This enables the Host to set cancellation requests for multiple Tx Buffers with one write to TXBCR. TXBCR bits are set only for those Tx Buffers configured via TXBC. The bits remain set until the corresponding bit of TXBRP is reset.

Value	Description
0	No cancellation pending.
1	Cancellation pending.



### 38.8.41 Tx Buffer Transmission Occurred

**Name:** TXBTO  
**Offset:** 0xD8  
**Reset:** 0x00000000  
**Property:** Read-only

Bit	31	30	29	28	27	26	25	24
	TO31	TO30	TO29	TO28	TO27	TO26	TO25	TO24
Access	R	R	R	R	R	R	R	R
Reset	0	0	0	0	0	0	0	0
Bit	23	22	21	20	19	18	17	16
	TO23	TO22	TO21	TO20	TO19	TO18	TO17	TO16
Access	R	R	R	R	R	R	R	R
Reset	0	0	0	0	0	0	0	0
Bit	15	14	13	12	11	10	9	8
	TO15	TO14	TO13	TO12	TO11	TO10	TO9	TO8
Access	R	R	R	R	R	R	R	R
Reset	0	0	0	0	0	0	0	0
Bit	7	6	5	4	3	2	1	0
	TO7	TO6	TO5	TO4	TO3	TO2	TO1	TO0
Access	R	R	R	R	R	R	R	R
Reset	0	0	0	0	0	0	0	0

#### Bits 0, 1, 2, 3, 4, 5, 6, 7, 8, 9, 10, 11, 12, 13, 14, 15, 16, 17, 18, 19, 20, 21, 22, 23, 24, 25, 26, 27, 28, 29, 30, 31 – TOn Transmission Occurred

Each Tx Buffer has its own Transmission Occurred bit.

The bits are set when the corresponding TXBRP bit is cleared after a successful transmission.

The bits are reset when a new transmission is requested by writing '1' to the corresponding bit of register TXBAR.

### 38.8.42 Tx Buffer Cancellation Finished

**Name:** TXBCF  
**Offset:** 0xDC  
**Reset:** 0x00000000  
**Property:** Read-only

Bit	31	30	29	28	27	26	25	24
	CF31	CF30	CF29	CF28	CF27	CF26	CF25	CF24
Access	R	R	R	R	R	R	R	R
Reset	0	0	0	0	0	0	0	0
Bit	23	22	21	20	19	18	17	16
	CF23	CF22	CF21	CF20	CF19	CF18	CF17	CF16
Access	R	R	R	R	R	R	R	R
Reset	0	0	0	0	0	0	0	0
Bit	15	14	13	12	11	10	9	8
	CF15	CF14	CF13	CF12	CF11	CF10	CF9	CF8
Access	R	R	R	R	R	R	R	R
Reset	0	0	0	0	0	0	0	0
Bit	7	6	5	4	3	2	1	0
	CF7	CF6	CF5	CF4	CF3	CF2	CF1	CF0
Access	R	R	R	R	R	R	R	R
Reset	0	0	0	0	0	0	0	0

#### Bits 0, 1, 2, 3, 4, 5, 6, 7, 8, 9, 10, 11, 12, 13, 14, 15, 16, 17, 18, 19, 20, 21, 22, 23, 24, 25, 26, 27, 28, 29, 30, 31 – CFn Cancellation Finished

Each Tx Buffer has its own Cancellation Finished bit.

The bits are set when the corresponding TXBRP bit is cleared after a cancellation was requested via TXBCR. In case the corresponding TXBRP bit was not set at the point of cancellation, CF is set immediately.

The bits are reset when a new transmission is requested by writing '1' to the corresponding bit of register TXBAR.

### 38.8.43 Tx Buffer Transmission Interrupt Enable

**Name:** TXBTIE  
**Offset:** 0xE0  
**Reset:** 0x00000000  
**Property:** -

Bit	31	30	29	28	27	26	25	24
	TIE31	TIE30	TIE29	TIE28	TIE27	TIE26	TIE25	TIE24
Access	R/W	R/W	R/W	R/W	R/W	R/W	R/W	R/W
Reset	0	0	0	0	0	0	0	0
Bit	23	22	21	20	19	18	17	16
	TIE23	TIE22	TIE21	TIE20	TIE19	TIE18	TIE17	TIE16
Access	R/W	R/W	R/W	R/W	R/W	R/W	R/W	R/W
Reset	0	0	0	0	0	0	0	0
Bit	15	14	13	12	11	10	9	8
	TIE15	TIE14	TIE13	TIE12	TIE11	TIE10	TIE9	TIE8
Access	R/W	R/W	R/W	R/W	R/W	R/W	R/W	R/W
Reset	0	0	0	0	0	0	0	0
Bit	7	6	5	4	3	2	1	0
	TIE7	TIE6	TIE5	TIE4	TIE3	TIE2	TIE1	TIE0
Access	R/W	R/W	R/W	R/W	R/W	R/W	R/W	R/W
Reset	0	0	0	0	0	0	0	0

#### Bits 0, 1, 2, 3, 4, 5, 6, 7, 8, 9, 10, 11, 12, 13, 14, 15, 16, 17, 18, 19, 20, 21, 22, 23, 24, 25, 26, 27, 28, 29, 30, 31 - TIE<sub>n</sub> Transmission Interrupt Enable

Each Tx Buffer has its own Transmission Interrupt Enable bit.

Value	Description
0	Transmission interrupt disabled.
1	Transmission interrupt enabled.

### 38.8.44 Tx Buffer Cancellation Finished Interrupt Enable

**Name:** TXBCIE  
**Offset:** 0xE4  
**Reset:** 0x00000000  
**Property:** -

Bit	31	30	29	28	27	26	25	24
	CFIE31	CFIE30	CFIE29	CFIE28	CFIE27	CFIE26	CFIE25	CFIE24
Access	R/W	R/W	R/W	R/W	R/W	R/W	R/W	R/W
Reset	0	0	0	0	0	0	0	0
Bit	23	22	21	20	19	18	17	16
	CFIE23	CFIE22	CFIE21	CFIE20	CFIE19	CFIE18	CFIE17	CFIE16
Access	R/W	R/W	R/W	R/W	R/W	R/W	R/W	R/W
Reset	0	0	0	0	0	0	0	0
Bit	15	14	13	12	11	10	9	8
	CFIE15	CFIE14	CFIE13	CFIE12	CFIE11	CFIE10	CFIE9	CFIE8
Access	R/W	R/W	R/W	R/W	R/W	R/W	R/W	R/W
Reset	0	0	0	0	0	0	0	0
Bit	7	6	5	4	3	2	1	0
	CFIE7	CFIE6	CFIE5	CFIE4	CFIE3	CFIE2	CFIE1	CFIE0
Access	R/W	R/W	R/W	R/W	R/W	R/W	R/W	R/W
Reset	0	0	0	0	0	0	0	0

#### Bits 0, 1, 2, 3, 4, 5, 6, 7, 8, 9, 10, 11, 12, 13, 14, 15, 16, 17, 18, 19, 20, 21, 22, 23, 24, 25, 26, 27, 28, 29, 30, 31 - CFIE<sub>n</sub> Cancellation Finished Interrupt Enable

Each Tx Buffer has its own Cancellation Finished Interrupt Enable bit.

Value	Description
0	Cancellation finished interrupt disabled.
1	Cancellation finished interrupt enabled.

### 38.8.45 Tx Event FIFO Configuration

**Name:** TXEFC  
**Offset:** 0xF0  
**Reset:** 0x00000000  
**Property:** Write-restricted

This register is write-restricted and only writable if bit fields CCCR.CCE = 1 and CCCR.INIT = 1.

Bit	31	30	29	28	27	26	25	24
			EFWM[5:0]					
Access			R/W	R/W	R/W	R/W	R/W	R/W
Reset			0	0	0	0	0	0
Bit	23	22	21	20	19	18	17	16
			EFS[5:0]					
Access			R	R	R	R	R	R
Reset			0	0	0	0	0	0
Bit	15	14	13	12	11	10	9	8
	EFSA[15:8]							
Access	R/W	R/W	R/W	R/W	R/W	R/W	R/W	R/W
Reset	0	0	0	0	0	0	0	0
Bit	7	6	5	4	3	2	1	0
	EFSA[7:0]							
Access	R/W	R/W	R/W	R/W	R/W	R/W	R/W	R/W
Reset	0	0	0	0	0	0	0	0

#### Bits 29:24 – EFWM[5:0] Event FIFO Watermark

Value	Description
0	Watermark interrupt disabled.
1 – 32	Level for Tx Event FIFO watermark interrupt (IR.TEFW).
>32	Watermark interrupt disabled.

#### Bits 21:16 – EFS[5:0] Event FIFO Size

The Tx Event FIFO elements are indexed from 0 to EFS - 1.

Value	Description
0	Tx Event FIFO disabled
1 – 32	Number of Tx Event FIFO elements.
>32	Values greater than 32 are interpreted as 32.

#### Bits 15:0 – EFSA[15:0] Event FIFO Start Address

Start address of Tx Event FIFO in Message RAM. When the CAN module addresses the Message RAM it addresses 32-bit words, not single bytes. The configurable start addresses are 32-bit word addresses, i.e. only bits 15 to 2 are evaluated, the two least significant bits are ignored. Bits 1 to 0 will always be read back as “00”.

### 38.8.46 Tx Event FIFO Status

**Name:** TXEFS  
**Offset:** 0xF4  
**Reset:** 0x00000000  
**Property:** Read-only

Bit	31	30	29	28	27	26	25	24	
							TEFL	EFF	
Access							R	R	
Reset							0	0	
Bit	23	22	21	20	19	18	17	16	
					EFPI[4:0]				
Access					R	R	R	R	R
Reset					0	0	0	0	0
Bit	15	14	13	12	11	10	9	8	
				EFGI[4:0]					
Access				R	R	R	R	R	
Reset				0	0	0	0	0	
Bit	7	6	5	4	3	2	1	0	
			EFFL[5:0]						
Access			R	R	R	R	R	R	
Reset			0	0	0	0	0	0	

#### Bit 25 – TEFL Tx Event FIFO Element Lost

This bit is a copy of interrupt flag IR.TEFL. When IR.TEFL is reset, this bit is also reset.

Value	Description
0	No Tx Event FIFO element lost.
1	Tx Event FIFO element lost, also set after write attempt to Tx Event FIFO of size zero.

#### Bit 24 – EFF Event FIFO Full

Value	Description
0	Tx Event FIFO not full.
1	Tx Event FIFO full.

#### Bits 20:16 – EFPI[4:0] Event FIFO Put Index

Tx Event FIFO write index pointer, range 0 to 31.

#### Bits 12:8 – EFGI[4:0] Event FIFO Get Index

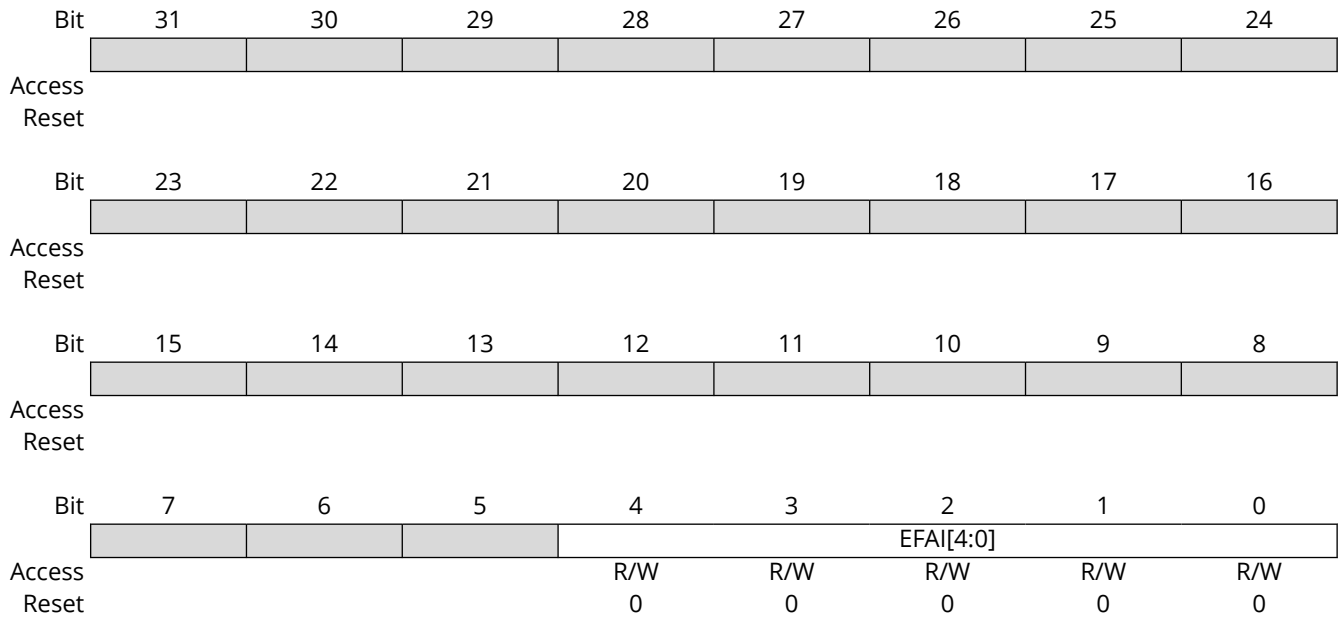
Tx Event FIFO read index pointer, range 0 to 31.

#### Bits 5:0 – EFFL[5:0] Event FIFO Fill Level

Number of elements stored in Tx Event FIFO, range 0 to 32.

### 38.8.47 Tx Event FIFO Acknowledge

**Name:** TXEFA  
**Offset:** 0xF8  
**Reset:** 0x00000000  
**Property:** -



#### Bits 4:0 – EFAI[4:0] Event FIFO Acknowledge Index

After the Host has read an element or a sequence of elements from the Tx Event FIFO it has to write the index of the last element read from Tx Event FIFO to EFAI. This will set the Tx Event FIFO Get Index TXEFS.EFGI to EFAI + 1 and update the FIFO 0 Fill Level TXEFS.EFFL.

## 39. Parallel Capture Controller (PCC)

### 39.1 Overview

The Parallel Capture Controller can be used to interface an external system, such as a CMOS digital image sensor, ADC, or DSP, and capture its parallel data.

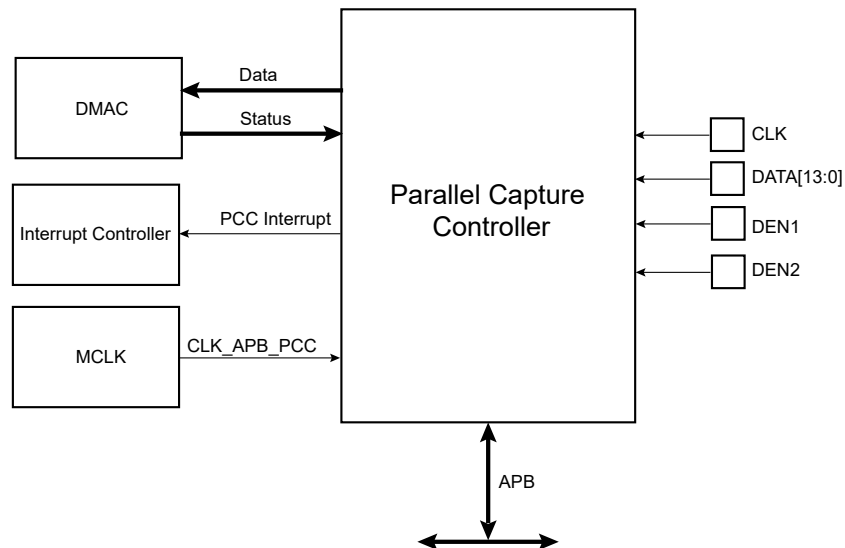
### 39.2 Features

The following are key features of the PCC module:

- One clock, up to 14-bit parallel data, and two Data Enable on I/O lines
- Data can be sampled every other time (for example, for chrominance sampling)
- Supports connection of the DMAC, which offers buffer reception without processor intervention
- Auto-scale feature available when 10, 12, or 14 bits data size is selected.
- Can be used to interface a CMOS Digital Image Sensor, an ADC and so on.

### 39.3 Block Diagram

Figure 39-1. Block Diagram



### 39.4 Signal Description

Signal	Description	Type
CLK	Digital input	PCC Clock
DATA[13:0]	Digital input	Data [13:0]
DEN1	Digital input	Data Enable 1
DEN2	Digital input	Data Enable 2

### 39.5 Peripheral Dependencies

<b>Peripheral Name</b>	Parallel Capture Controller (PCC)
<b>Base Address</b>	0x4300_2C00 (Peripheral Bus D)
<b>NVIC IRQ Index:Source</b>	129 : DRDY, OVRE
<b>MCLK APB Clock(1)</b>	CLK_APB_PCC, Disabled, APBDMASK.PCC
<b>GCLK Peripheral Channel Index:Clock Name</b>	n/a



<b>PAC Peripheral Peripheral Identifier (PAC.WRCTRL)</b>	Not supported by PAC
<b>DMA Trigger Index:Source (DMAC.CHCTRLAk,k = 0,1,...31)</b>	80 : RX
<b>Note:</b>	
1. Clock Name, Default State, Mask Field.	

### 39.5.1 Power Management

The PCC will continue to operate in any Sleep mode where the selected source clock is running.

### 39.5.2 Clocks

The PCC bus clock (CLK\_APB\_PCC) is provided by the [Main Clock Controller \(MCLK\)](#) through the AHB-APB D bridge. The clock is enabled and disabled by writing the PCC bit the in the APB D Mask register (MCLK.APBDMASK.PCC).

For capturing operation, the external device has to provide a PCC clock signal (PCC\_CLK) synchronous to the data received (pixel clock) through a pin. Refer to the [PORT](#) section and the [Pinout](#) table for additional information.

Writing any of the registers does not require the PCC\_CLK to be enabled.



**Important:** The CLK\_APB\_PCC clock frequency must be at least twice the PCC\_CLK frequency.

### 39.5.3 DMA

The DMAC can be configured to use the RX channel of the PCC as trigger source.

If configured, a trigger signal is send to the DMAC when data is received by the PCC, such that the DMAC will automatically read the received data buffer. The buffer ready signal will be automatically clear upon the read done by the DMAC.

### 39.5.4 Debug Operation

When the CPU is halted in Debug mode, the PCC will not halt normal operation.

**Note:** A buffer overflow condition will occur if the received data buffer is not read by CPU or CPU DMAC.

### 39.5.5 Register Access Protection

To prevent any single software error from corrupting PCC behavior, certain registers in the address space can be write-protected by setting the WPEN bit in the Write Protection Mode Register (WPMR).

If a write access to a write-protected register is detected, the WPVS flag in the Write Protection Status Register (WPSR) is set and WPSR.WPVSRC indicates the register in which the write access has been attempted.

The WPVS bit is automatically cleared after reading WPSR.

The following registers can be write-protected:

- PCC Mode Register

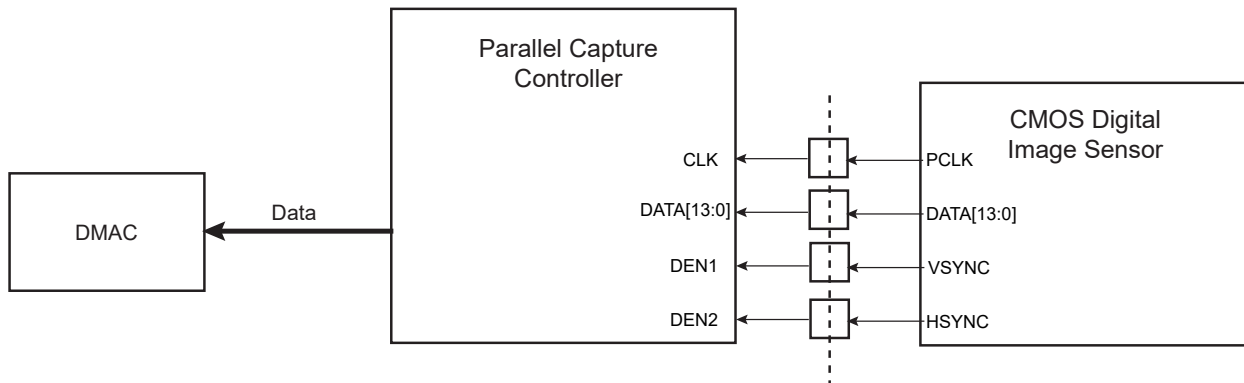
## 39.6 Functional Description

### 39.6.1 Principle of Operation

For better understanding and to ease reading, the following description uses an example with a CMOS digital image sensor.

The CMOS digital image sensor provides a sensor clock, an 10-bit data synchronous with the sensor clock and two data enables which are also synchronous with the sensor clock.

**Figure 39-2.** Parallel Capture Controller Connection with CMOS Digital Image Sensor



The PCC must be configured first, and is enabled by writing a '1' to the Parallel Capture Enable bit in the Mode Register (MR.PCEN).

Once enabled, the PCC samples the data at rising edge of the sensor clock, and resynchronizes it with the PCC clock domain.

The input data bus size can be programmed using the Input Data Size bit field (MR.ISIZE).

A re-initialization of the internal mechanism of the PCC can be automatically done by setting the CID register when a falling edge of the DEN1 or DEN2 is detected. This feature allows glitch filtering and prevents image de-synchronization.

The number of the data which can be read in the Reception Holding Register (RHR) can be programmed by writing the Data Size bit field (MR.DSIZE). The PCC samples one or several sensor data, according to the DSIZE value.

If the MR.SCALE bit is written to '1' and MR.ISIZE  $\neq$  0, the sampled data is automatically up-scaled to 16 bits. When the right number of data has been sampled, data are stored in the RHR, and the Data Ready flag in the Interrupt Status Register (ISR.DRDY) is set to '1'.

The PCC can be associated with a reception channel of the DMA Controller (DMAC). This performs reception transfer from the PCC to a memory buffer without any intervention from the CPU.

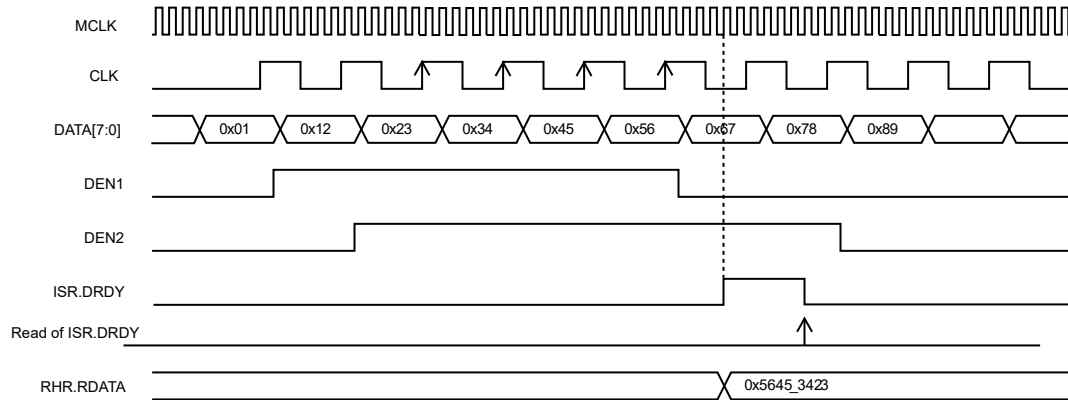
The PCC can be configured to either comply with the sensor data enable signals, or not. If the Always Sampling bit in the Mode Register (MR.ALWYS) is written to '0', the PCC samples the sensor data at the rising edge of the sensor clock only if both data enable signals are active (at '1'). If ALWYS is written to '1', the PCC samples the sensor data at the rising edge of the sensor clock, independent of the data enable signals.

The PCC can be configured to sample the sensor data only every other time. This is particularly useful when only the luminance Y from a YUV422 data stream of a CMOS digital image sensor is to be sampled. If the Half Sampling bit in the Mode Register (MR.HALFS) is written to '0', the PCC samples the sensor data as configured above. If MR.HALFS = 1, the PCC samples the sensor data as configured above (i.e., respecting the MR.ALWYS setting), but only one time out of two.

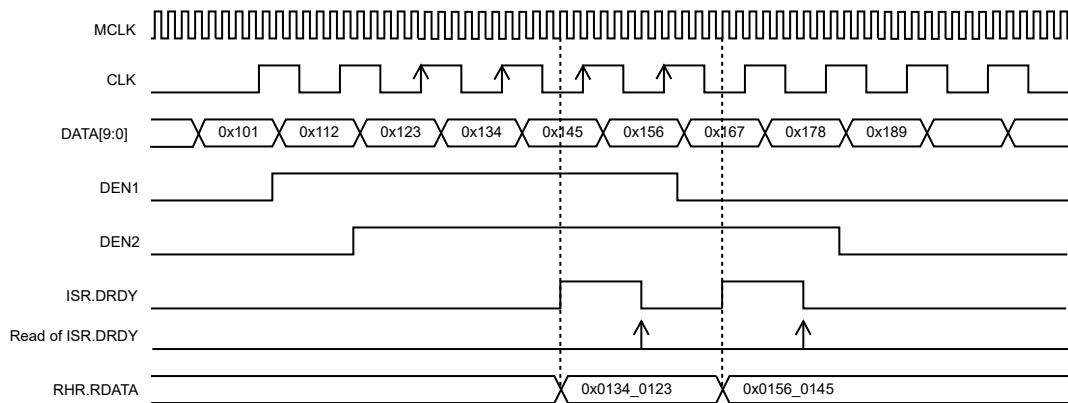
The PCC can either sample the even or odd sensor data, depending on the First Sample bit (MR.FRSTS). If sensor data are numbered with an index from zero to n in the order they are received and FRSTS = 0, only data with an even index are sampled. For FRSTS = 1, only data with an odd index are sampled.

If data are ready in the Reception Holding Register (RHR) but it is not read before new data is stored in RHR, an overrun error occurs: The previous data is lost and the Overrun Error flag in the Interrupt Status Register (ISR.OVRE) is set. This flag is automatically cleared when ISR is read (reset after read). The flags DRDY and OVRE can be a source of the PCC interrupt.

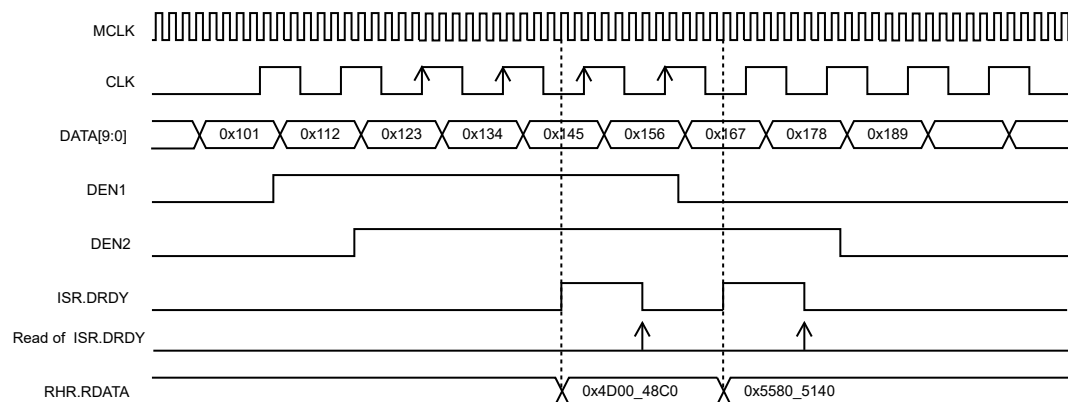
**Figure 39-3.** PCC Waveforms (DSIZE = 4\_DATA, ALWAYS = 0, HALFS = 0)



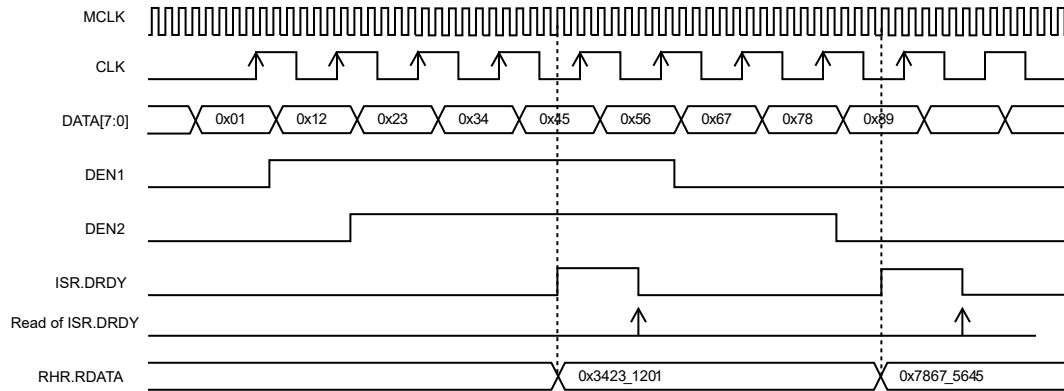
**Figure 39-4.** PCC Waveforms (ISIZE = 10\_BITS, DSIZE = 2\_DATA, ALWAYS = 0, HALFS = 0, SCALE = 0)



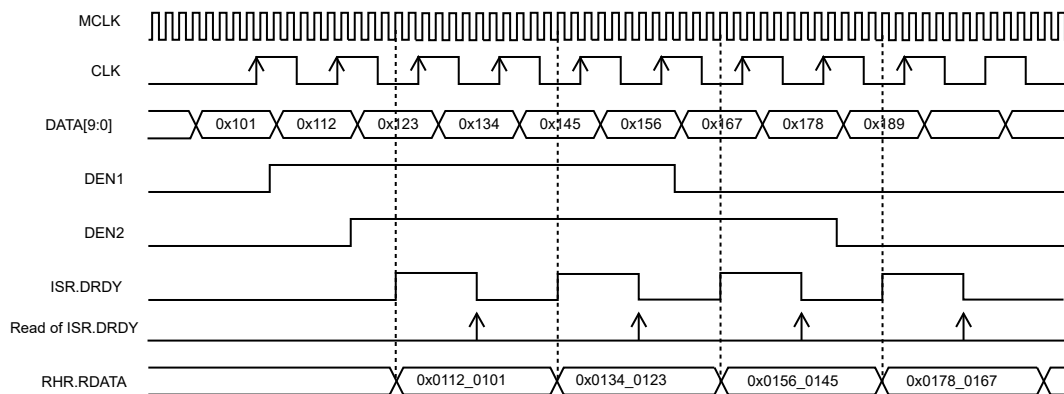
**Figure 39-5.** PCC Waveforms (ISIZE = 10\_BITS, DSIZE = 2\_DATA, ALWAYS = 0, HALFS = 0, SCALE = 1)



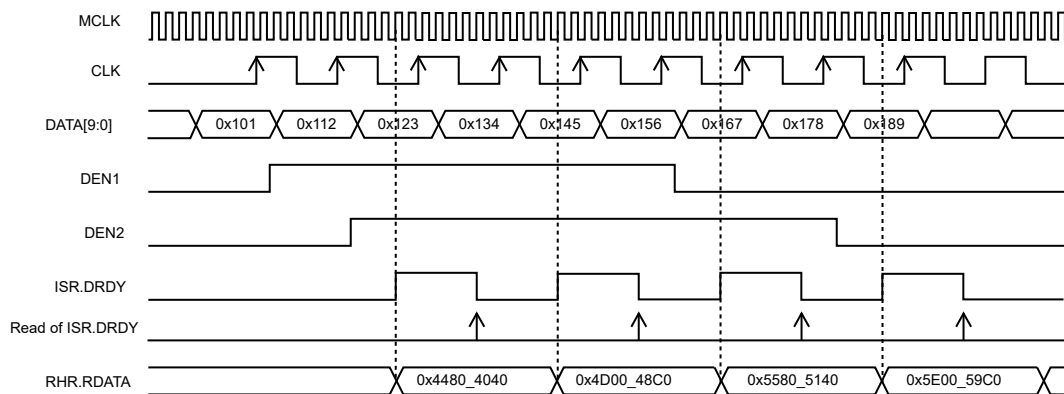
**Figure 39-6.** PCC Waveforms (DSIZE = 4\_DATA, ALWAYS = 1, HALFS = 0)



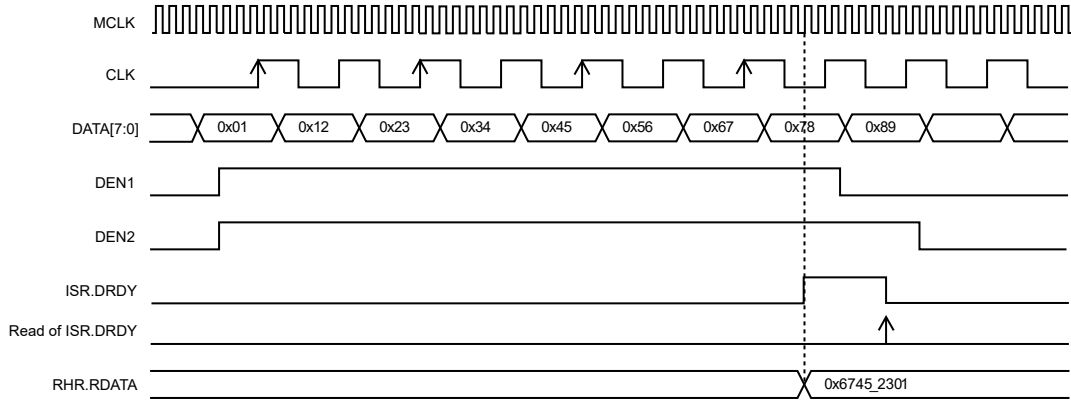
**Figure 39-7.** PCC Waveforms (ISIZE = 10\_BITS, DSIZE = 2\_DATA, ALWAYS = 1, HALFS = 0, SCALE = 0)



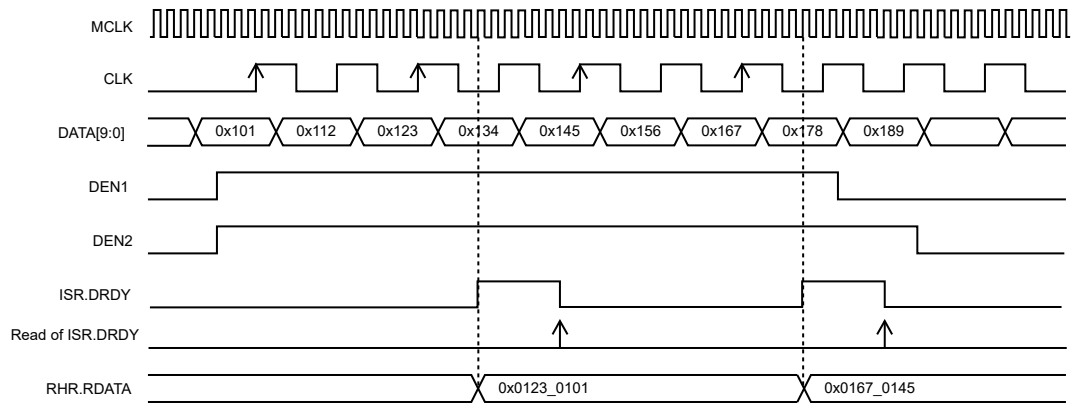
**Figure 39-8.** PCC Waveforms (ISIZE = 10\_BITS, DSIZE = 2\_DATA, ALWAYS = 1, HALFS = 0, SCALE = 1)



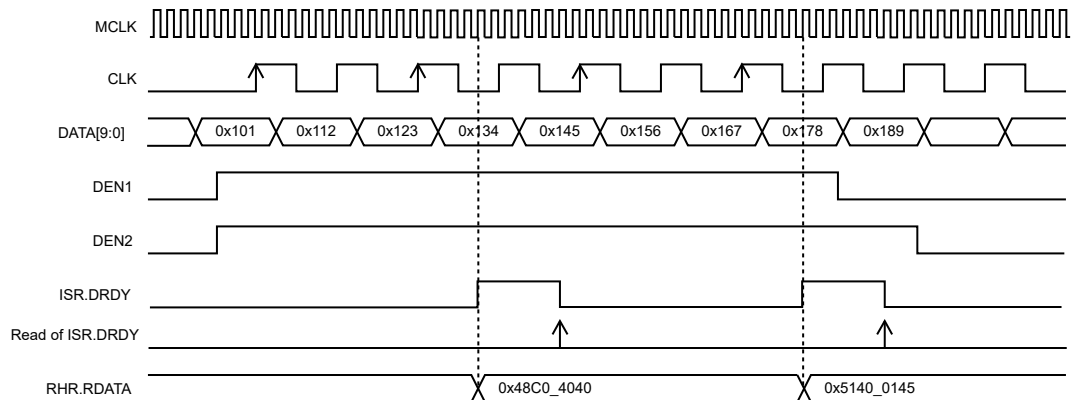
**Figure 39-9.** PCC Waveforms (DSIZE = 4\_DATA, ALWAYS = 0, HALFS = 1, FRSTS = 0)



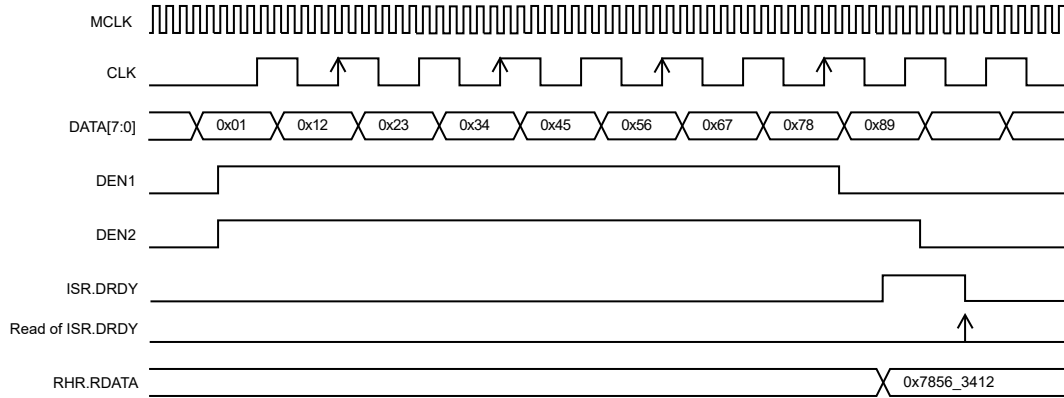
**Figure 39-10.** PCC Waveforms (ISIZE = 10\_BITS, DSIZE = 2\_DATA, ALWAYS = 0, HALFS = 1, FRSTS = 0, SCALE = 0)



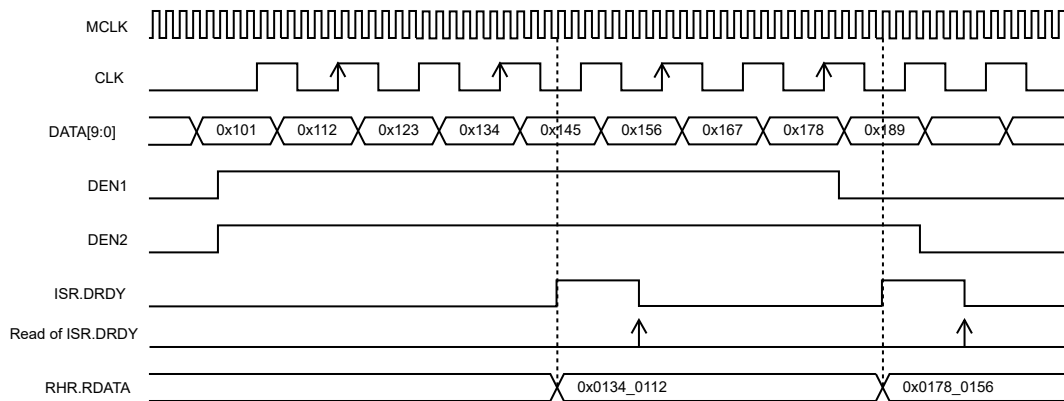
**Figure 39-11.** PCC Waveforms (ISIZE = 10\_BITS, DSIZE = 2\_DATA, ALWAYS = 0, HALFS = 1, FRSTS = 0, SCALE = 1)



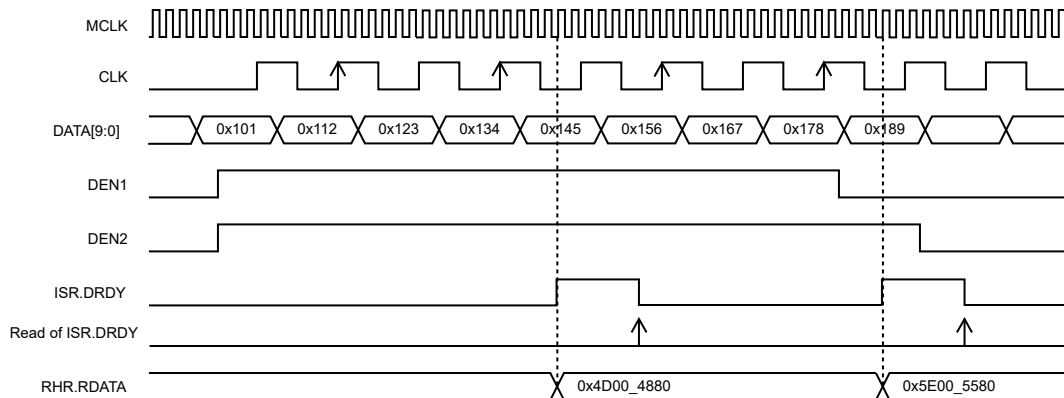
**Figure 39-12.** PCC Waveforms (DSIZE = 4\_DATA, ALWAYS = 0, HALFS = 1, FRSTS = 1)



**Figure 39-13.** PCC Waveforms (ISIZE = 10\_BITS, DSIZE = 2\_DATA, ALWAYS = 0, HALFS = 1, FRSTS = 1, SCALE = 0)



**Figure 39-14.** PCC Waveforms (ISIZE = 10\_BITS, DSIZE = 2\_DATA, ALWAYS = 0, HALFS = 1, FRSTS = 1, SCALE = 1)



### 39.6.2 Register Access Protection

The configuration bit fields ISIZE, SCALE, DSIZE, ALWAYS, HALFS and FRSTS in the Mode Register (MR) can be changed only if the PCC is disabled at this time (MR.PCEN = 0).

### 39.6.3 Programming Sequence

#### 39.6.3.1 Without DMAC

1. Write the Interrupt Enable and Interrupt Disable Registers (IER and IDR) in order to configure the PCC interrupt mask.

2. Write the Mode Register (MR) fields ISIZE, SCALE, DSIZE, ALWAYS, HALFS and FRSTS in order to configure the PCC. Do not enable the PCC in this write access.
3. Write the PCC Enable bit in the Mode Register (MR.PCEN) to '1' in order to enable the PCC. Do not change the configuration from the previous step.
4. Wait for a Data Ready, either by polling the Data Ready flag in the Interrupt Status Register (ISR.DRDY) or by waiting for the corresponding interrupt.
5. Check the Overrun Error flag (ISR.OVRE).
6. Read the data in the Reception Holding Register (RHR).
7. If new data are expected, go to step 4.
8. Disable the PCC by writing MR.PCEN to '0' *without* changing the configuration.

### 39.6.3.2 With DMAC

1. Write the Interrupt Enable and Interrupt Disable Registers (IER and IDR) in order to configure the PCC interrupt mask.
2. Configure DMAC transfer in the DMAC registers.
3. Write the Mode Register (MR) fields ISIZE, SCALE, DSIZE, ALWAYS, HALFS and FRSTS in order to configure the PCC. Do not enable the PCC in this write access.
4. Write the PCC Enable bit in the Mode Register (MR.PCEN) to '1' in order to enable the PCC. Do not change the configuration from the previous step.
5. Wait for the DMA status flag to indicate that the buffer transfer is complete.
6. Check the Overrun Error flag (ISR.OVRE).
7. If a new buffer transfer is expected, go to step 5.
8. Disable the PCC by writing MR.PCEN to '0' *without* changing the configuration.

## 39.7 Register Summary

Offset	Name	Bit Pos.	7	6	5	4	3	2	1	0
0x00	MR	7:0			DSIZE[1:0]					PCEN
		15:8					FRSTS	HALFS	ALWYS	SCALE
		23:16							ISIZE[2:0]	
		31:24	CID[1:0]							
0x04	IER	7:0							OVRE	DRDY
		15:8								
		23:16								
0x08	IDR	7:0							OVRE	DRDY
		15:8								
		23:16								
0x0C	IMR	7:0							OVRE	DRDY
		15:8								
		23:16								
0x10	ISR	7:0							OVRE	DRDY
		15:8								
		23:16								
0x14	RHR	7:0					RDATA[7:0]			
		15:8					RDATA[15:8]			
		23:16					RDATA[23:16]			
		31:24					RDATA[31:24]			
0x18 ... 0xDF	Reserved									
0xE0	WPMR	7:0								WPEN
		15:8				WPKEY[7:0]				
		23:16				WPKEY[15:8]				
		31:24				WPKEY[23:16]				
0xE4	WPSR	7:0								WPVS
		15:8				WPVSR[7:0]				
		23:16				WPVSR[15:8]				
		31:24								



### 39.7.1 PCC Mode Register

**Name:** MR  
**Offset:** 0x00  
**Reset:** 0x00000000  
**Property:** -

This register can only be written if the WPEN bit is cleared in the Write Protection Mode Register.

**Table 39-1. Register Bit Attribute Legend**

Symbol	Description	Symbol	Description	Symbol	Description
<b>R</b>	Readable bit	<b>HC</b>	Cleared by Hardware	(Grey cell)	Unimplemented
<b>W</b>	Writable bit	<b>HS</b>	Set by Hardware	<b>X</b>	Bit is unknown at Reset
<b>K</b>	Write to clear	<b>S</b>	Software settable bit	—	—

Bit	31	30	29	28	27	26	25	24
	CID[1:0]							
Access	R/W	R/W						
Reset	0	0						
Bit	23	22	21	20	19	18	17	16
						ISIZE[2:0]		
Access						R/W	R/W	R/W
Reset						0	0	0
Bit	15	14	13	12	11	10	9	8
					FRSTS	HALFS	ALWYS	SCALE
Access					R/W	R/W	R/W	R/W
Reset					0	0	0	0
Bit	7	6	5	4	3	2	1	0
			DSIZE[1:0]					PCEN
Access			R/W	R/W				R/W
Reset			0	0				0

#### Bits 31:30 – CID[1:0] Clear If Disabled

Clears status flags if disabled. These bits are useful to re-initialize the internal mechanism of the PCC to avoid corrupted data due to glitches. Each time a falling edge of the selected DEN1 or DEN2 signal is detected, the internal mechanism of the PCC is re-initialized to avoid alignment issues.

Value	Description
0x0	Clear not enabled
0x1	Clear on falling edge on DEN1 enabled
0x2	Clear on falling edge on DEN2 enabled
0x3	Clear on falling edge on either DEN1 or DEN2 enabled

#### Bits 18:16 – ISIZE[2:0] Input Data Size

Value	Name	Description
0x0	8BITS	Input data bus size is 8 bits
0x1	10BITS	Input data bus size is 10 bits
0x2	12BITS	Input data bus size is 12 bits
0x3	14BITS	Input data bus size is 14 bits

**Bit 11 – FRSTS** First Sample

This bit is useful only if the HALFS bit is set to 1. If data are numbered in the order that they are received with an index from 0 to n.

Value	Description
0	Only data with an even index are sampled.
1	Only data with an odd index are sampled.

**Bit 10 – HALFS** Half Sampling

This function is independent from the ALWYS bit.

Value	Description
0	The Parallel Capture Controller samples all the data.
1	The Parallel Capture Controller samples the data only every other time.

**Bit 9 – ALWYS** Always Sampling

Value	Description
0	The parallel capture Controller samples the data when both data enables are active.
1	The parallel capture controller always samples the data, regardless of the state of data enable.

**Bit 8 – SCALE** Scale Data

Value	Description
0	No effect.
1	When input data size is not equal to 8 bits (ISIZE ≠ 0), the data stored in the PCC_RHR is automatically up-scaled to 16 bits.

**Bits 5:4 – DSIZE[1:0]** Data Size

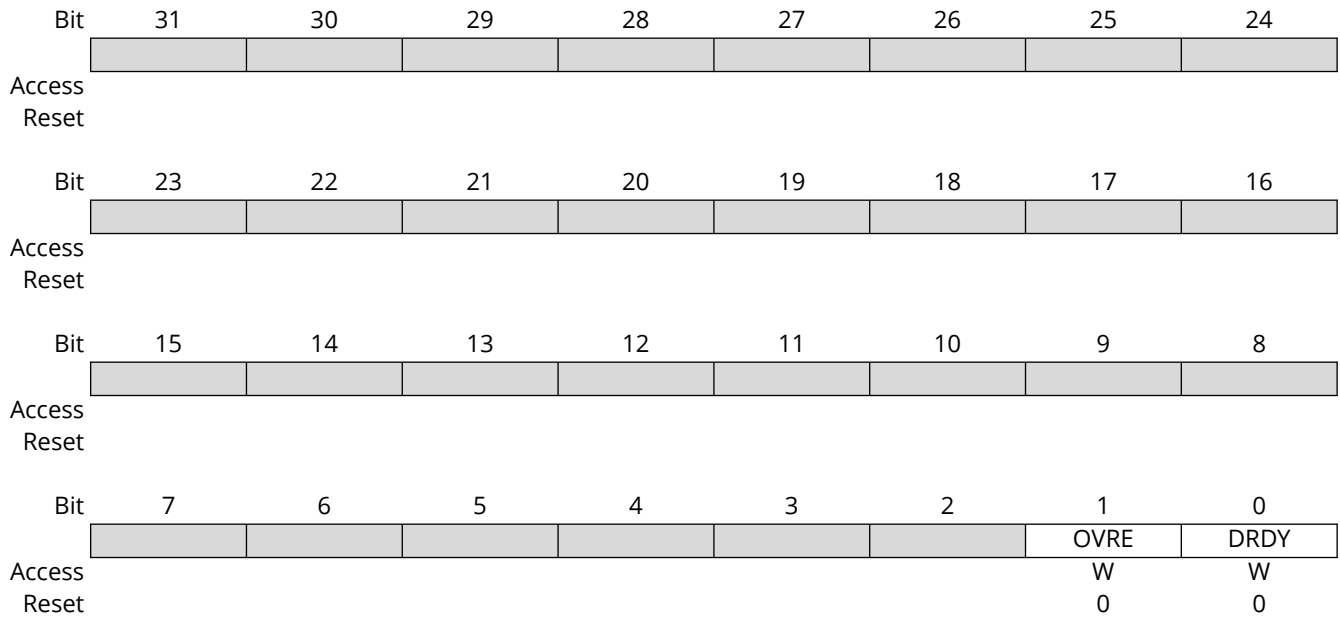
Value	Name	Description
0x0	1DATA	1 data is read in the PCC_RHR
0x1	2DATA	2 data are read in the PCC_RHR
0x2	4DATA	4 data are read in the PCC_RHR (only for 8 bits data size, ISIZE = 0)
0x3	-	Reserved

**Bit 0 – PCEN** Parallel Capture Enable

Value	Description
0	The Parallel Capture Controller is disabled.
1	The Parallel Capture Controller is enabled.

### 39.7.2 Interrupt Enable Register

**Name:** IER  
**Offset:** 0x04  
**Reset:** 0x00000000  
**Property:** -

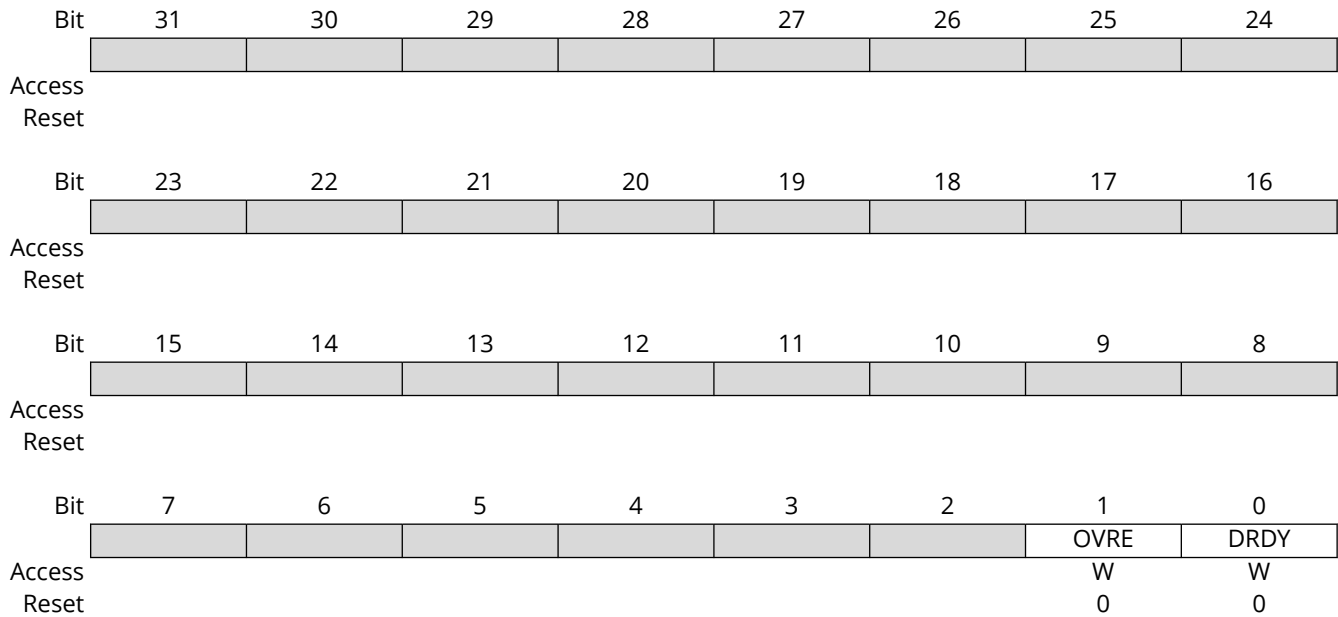


**Bit 1 - OVRE** Overrun Error Interrupt Enable  
 Writing a '1' to this register enables the Overrun Error interrupt.  
 Writing a '0' has no effect.

**Bit 0 - DRDY** Data Ready Interrupt Enable  
 Writing a '1' to this register enables the Data Ready Interrupt interrupt.  
 Writing a '0' has no effect.

### 39.7.3 Interrupt Disable Register

**Name:** IDR  
**Offset:** 0x08  
**Reset:** 0x00000000  
**Property:** -



**Bit 1 - OVRE** Overrun Error Interrupt Disable

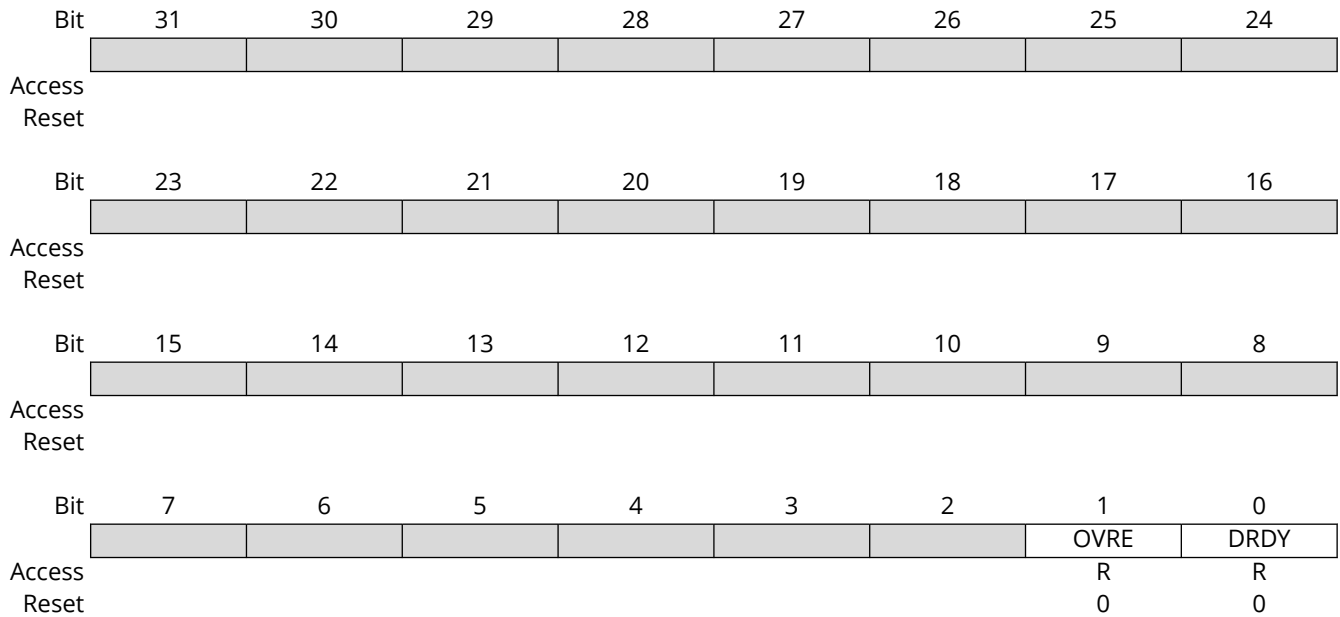
Writing a '1' to this register disables the Overrun Error interrupt.  
 Writing a '0' has no effect.

**Bit 0 - DRDY** Data Ready Interrupt Disable

Writing a '1' to this register disables the Data Ready interrupt.  
 Writing a '0' has no effect.

### 39.7.4 Interrupt Mask Register

**Name:** IMR  
**Offset:** 0x0C  
**Reset:** 0x00000000  
**Property:** -



#### Bit 1 - OVRE Overrun Error Interrupt Mask

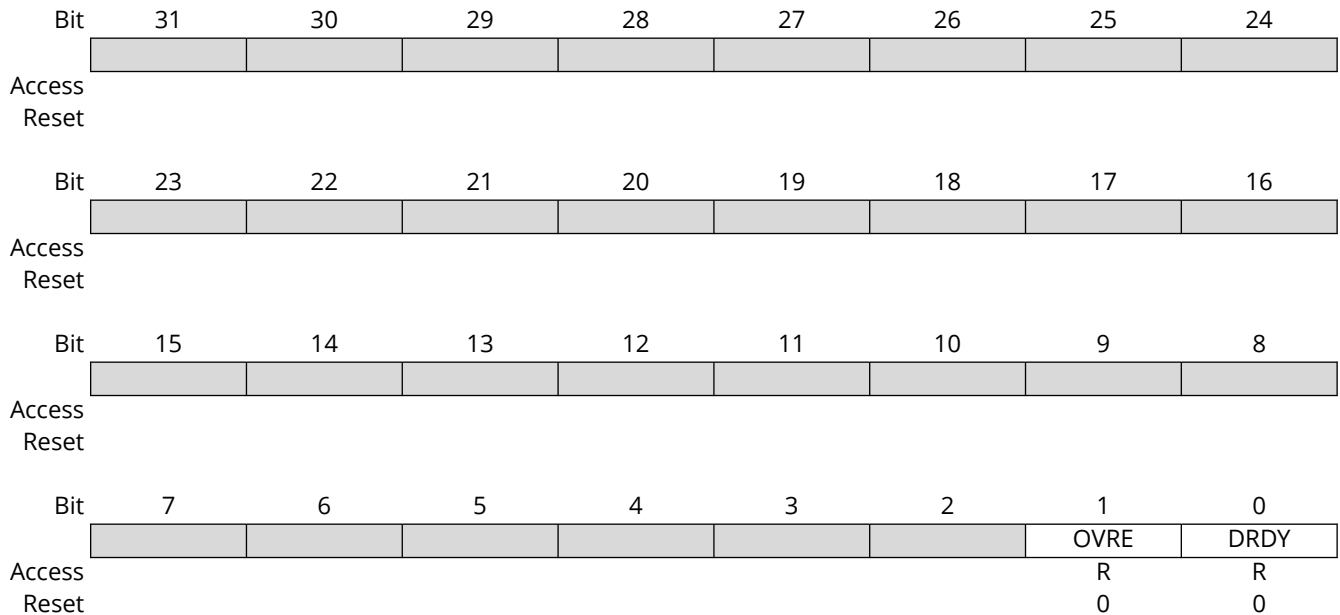
Value	Description
1	The Overrun Error interrupt is enabled.
0	The Overrun Error interrupt is not enabled.

#### Bit 0 - DRDY Data Ready Interrupt Mask

Value	Description
1	The Data Ready interrupt is enabled.
0	The Data Ready interrupt is not enabled.

### 39.7.5 Interrupt Status Register

**Name:** ISR  
**Offset:** 0x10  
**Reset:** 0x00000000  
**Property:** -



#### Bit 1 - OVRE Overrun Error Interrupt Status

The OVRE flag is automatically reset when this register is read or when the PCC is disabled.

Value	Description
0	No overrun error occurred since the last read of this register.
1	At least one overrun error occurred since the last read of this register.

#### Bit 0 - DRDY Data Ready Interrupt Status

The DRDY flag is automatically reset when RHR is read or when the PCC is disabled.

Value	Description
0	No new data is ready to be read since the last read of RHR.
1	New data is ready to be read since the last read of RHR.

### 39.7.6 Reception Holding Register

**Name:** RHR  
**Offset:** 0x14  
**Reset:** 0x00000000  
**Property:** -

**Table 39-2.** Register Bit Attribute Legend

Symbol	Description	Symbol	Description	Symbol	Description
<b>R</b>	Readable bit	<b>HC</b>	Cleared by Hardware	(Grey cell)	Unimplemented
<b>W</b>	Writable bit	<b>HS</b>	Set by Hardware	<b>X</b>	Bit is unknown at Reset
<b>K</b>	Write to clear	<b>S</b>	Software settable bit	—	—

Bit	31	30	29	28	27	26	25	24
	RDATA[31:24]							
Access	R	R	R	R	R	R	R	R
Reset	0	0	0	0	0	0	0	0
Bit	23	22	21	20	19	18	17	16
	RDATA[23:16]							
Access	R	R	R	R	R	R	R	R
Reset	0	0	0	0	0	0	0	0
Bit	15	14	13	12	11	10	9	8
	RDATA[15:8]							
Access	R	R	R	R	R	R	R	R
Reset	0	0	0	0	0	0	0	0
Bit	7	6	5	4	3	2	1	0
	RDATA[7:0]							
Access	R	R	R	R	R	R	R	R
Reset	0	0	0	0	0	0	0	0

#### Bits 31:0 – RDATA[31:0] Reception Data

ISIZE	SCALE	DSIZE	Description
8_BITS	-	1_DATA	RDATA[7:0] is useful
		2_DATA	RDATA[15:0] is useful
		4_DATA	RDATA[31:0] is useful
10_BITS	0 (OFF)	1_DATA	RDATA[9:0] is useful
		2_DATA	RDATA[9:0] and RDATA[25:16] are useful
	1 (ON)	1_DATA	RDATA[15:0] is useful
		2_DATA	RDATA[31:0] is useful
12_BITS	0 (OFF)	1_DATA	RDATA[11:0] is useful
		2_DATA	RDATA[11:0] and RDATA[27:16] are useful
	1 (ON)	1_DATA	RDATA[15:0] is useful
		2_DATA	RDATA[31:0] is useful
14_BITS	0 (OFF)	1_DATA	RDATA[13:0] is useful
		2_DATA	RDATA[13:0] and RDATA[29:16] are useful
	1 (ON)	1_DATA	RDATA[15:0] is useful
		2_DATA	RDATA[31:0] is useful

### 39.7.7 Write Protection Mode Register

**Name:** WPMR  
**Offset:** 0xE0  
**Reset:** 0x00000000  
**Property:** -

**Table 39-3.** Register Bit Attribute Legend

Symbol	Description	Symbol	Description	Symbol	Description
<b>R</b>	Readable bit	<b>HC</b>	Cleared by Hardware	(Grey cell)	Unimplemented
<b>W</b>	Writable bit	<b>HS</b>	Set by Hardware	<b>X</b>	Bit is unknown at Reset
<b>K</b>	Write to clear	<b>S</b>	Software settable bit	—	—

Bit	31	30	29	28	27	26	25	24
	WPKEY[23:16]							
Access	R/W	R/W	R/W	R/W	R/W	R/W	R/W	R/W
Reset	0	0	0	0	0	0	0	0
Bit	23	22	21	20	19	18	17	16
	WPKEY[15:8]							
Access	R/W	R/W	R/W	R/W	R/W	R/W	R/W	R/W
Reset	0	0	0	0	0	0	0	0
Bit	15	14	13	12	11	10	9	8
	WPKEY[7:0]							
Access	R/W	R/W	R/W	R/W	R/W	R/W	R/W	R/W
Reset	0	0	0	0	0	0	0	0
Bit	7	6	5	4	3	2	1	0
								WPEN
Access								R/W
Reset								0

#### Bits 31:8 – WPKEY[23:0] Write Protection Key

Value	Name	Description
0x504343	PASSWD	Writing any other value in this field aborts the write operation of the WPEN bit. Always reads as 0.

#### Bit 0 – WPEN Write Protection Enable

Value	Description
0	Disables the write protection if WPKEY corresponds to 0x504343 (“PCC” in ASCII).
1	Enables the write protection if WPKEY corresponds to 0x504343 (“PCC” in ASCII).



### 39.7.8 Write Protection Status Register

**Name:** WPSR  
**Offset:** 0xE4  
**Reset:** 0x00000000  
**Property:** -

**Table 39-4.** Register Bit Attribute Legend

Symbol	Description	Symbol	Description	Symbol	Description
<b>R</b>	Readable bit	<b>HC</b>	Cleared by Hardware	(Grey cell)	Unimplemented
<b>W</b>	Writable bit	<b>HS</b>	Set by Hardware	<b>X</b>	Bit is unknown at Reset
<b>K</b>	Write to clear	<b>S</b>	Software settable bit	—	—

Bit	31	30	29	28	27	26	25	24
Access								
Reset								
Bit	23	22	21	20	19	18	17	16
Access	WPVSR[15:8]							
Reset	R	R	R	R	R	R	R	R
Reset	0	0	0	0	0	0	0	0
Bit	15	14	13	12	11	10	9	8
Access	WPVSR[7:0]							
Reset	R	R	R	R	R	R	R	R
Reset	0	0	0	0	0	0	0	0
Bit	7	6	5	4	3	2	1	0
Access								WPVS
Reset								R
Reset								0

#### Bits 23:8 – WPVSR[15:0] Write Protection Violation Source

When WPVS = 1, WPVSR indicates the register address offset at which a write access has been attempted.

#### Bit 0 – WPVS Write Protection Violation Status

Value	Description
0	No write protection violation has occurred since the last read of the WPSR.
1	A write protection violation has occurred since the last read of the WPSR. If this violation is an unauthorized attempt to write a protected register, the associated violation is reported into field WPVSR.

## 40. Universal Serial Bus (USB)

### 40.1 Overview

The Universal Serial Bus interface (USB) module complies with the Universal Serial Bus (USB) 2.1 specification supporting both device and embedded host modes.

The USB device mode supports 8 endpoint addresses. All endpoint addresses have one input and one output endpoint, for a total of 16 endpoints. Each endpoint is fully configurable in any of the four transfer types: control, interrupt, bulk or isochronous. The USB host mode supports up to 8 pipes. The maximum data payload size is selectable up to 1023 bytes.

Internal SRAM is used to keep the configuration and data buffer for each endpoint. The memory locations used for the endpoint configurations and data buffers is fully configurable. The amount of memory allocated is dynamic according to the number of endpoints in use, and the configuration of these. The USB module has a built-in Direct Memory Access (DMA) and will read/write data from/to the system RAM when a USB transaction takes place. No CPU or DMA Controller resources are required.

To maximize throughput, an endpoint can be configured for ping-pong operation. When this is done the input and output endpoint with the same address are used in the same direction. The CPU or DMA Controller can then read/write one data buffer while the USB module writes/reads from the other buffer. This gives double buffered communication.

Multi-packet transfer enables a data payload exceeding the maximum packet size of an endpoint to be transferred as multiple packets without any software intervention. This reduces the number of interrupts and software intervention needed for USB transfers.

For low power operation the USB module can put the microcontroller in any sleep mode when the USB bus is idle and a suspend condition is given. Upon bus resume, the USB module can wake the microcontroller from any sleep mode.

### 40.2 Features

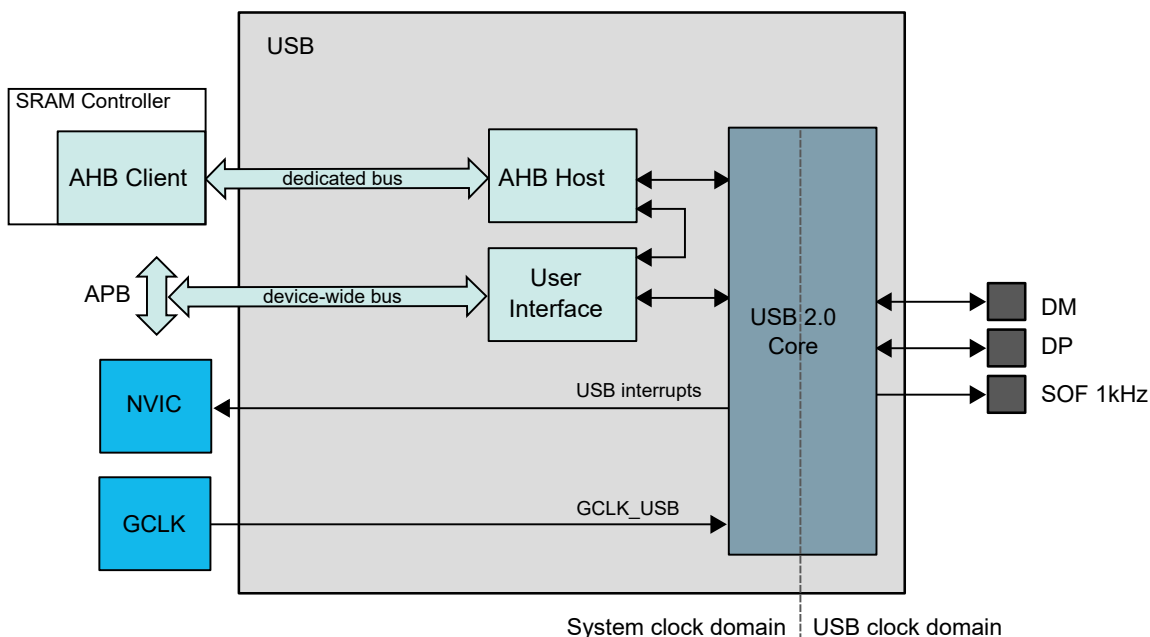
The following are key features of the USB:

- Compatible with the USB 2.1 specification
- USB Embedded Host and Device mode
- Supports full (12 Mbit/s) and low (1.5 Mbit/s) speed communication
- Supports Link Power Management (LPM-L1) protocol
- On-chip transceivers with built-in pull-ups and pull-downs
- On-Chip USB serial resistors
- 1 kHz SOF clock available on external pin
- Device mode
  - Supports 8 IN endpoints and 8 OUT endpoints
  - No endpoint size limitations
  - Built-in DMA with multi-packet and dual bank for all endpoints
  - Supports feedback endpoint
  - Supports crystal less clock
- Host mode
  - Supports 8 physical pipes
  - No pipe size limitations
  - Supports multiplexed virtual pipe on one physical pipe to allow an unlimited USB tree

- Built-in DMA with multi-packet support and dual bank for all pipes
- Supports feedback endpoint
- Supports the USB 2.0 Phase-locked SOFs feature

### 40.3 USB Block Diagram

Figure 40-1. LS/FS Implementation: USB Block Diagram



### 40.4 Signal Description

Pin Name	Pin Description	Type
DM	Data -: Differential Data Line - Port	Input/Output
DP	Data +: Differential Data Line + Port	Input/Output
SOF 1kHz	SOF Output	Output

Refer to the [Pinout](#) for details on the pin mapping for this peripheral. One signal can be mapped on several pins.

### 40.5 Peripheral Dependencies

<b>Peripheral Name</b>	USB – Universal Serial Bus
<b>Base Address</b>	0x4100_0000 (Peripheral Bus B)
<b>NVIC IRQ Index:Source</b>	80 : EORSM/DNRSM, EORST/RST, LPM/DCONN, LPMSUSP/DDISC, RAMACER, RXSTP/TXSTP 0..7, STALL0/STALL 0..7, STALL1 0..7, SUSPEND, TRFAIL0/TRFAIL 0..7, TRFAIL1/PERR 0..7, UPRSM, WAKEUP 81 : SOF/HOFSOF 82 : TRCPT0 0..7 83 : TRCPT1 0..7
<b>MCLK APB Clock (1)</b>	CLK_USB_AHB, Enabled, AHBMASK.USB CLK_USB_APB, Disabled ,APBBMASK.USB
<b>GCLK Peripheral Channel Index:Clock Name (2)</b>	10 : GCLK_USB
<b>PAC Peripheral Identifier (PAC.WRCTRL)</b>	32
<b>Note:</b>	
1.	Clock Name, Default State, Mask Field.

### 40.5.1 I/O Lines

The USB pins may be multiplexed with the I/O lines Controller. The user must first configure the I/O Controller to assign the USB pins to their peripheral functions.

A 1kHz SOF clock is available on an external pin. The user must first configure the I/O Controller to assign the 1kHz SOF clock to the peripheral function. The SOF clock is available for device and host mode.

### 40.5.2 Power Management

This peripheral can continue to operate in any Sleep mode where its source clock is running. The interrupts can wake up the device from Sleep modes. Events connected to the event system can trigger other operations in the system without exiting Sleep modes.

### 40.5.3 Clocks

The USB bus clock (CLK\_USB\_AHB) can be enabled and disabled in the Main Clock module, MCLK, and the default state of CLK\_USB\_AHB can be found in the [Peripheral Clock Masking](#).

A generic clock (GCLK\_USB) is required to clock the USB. This clock must be configured and enabled in the [Generic Clock Controller](#) before using the USB.

This generic clock is asynchronous to the bus clock (CLK\_USB\_AHB). Due to this asynchronicity, writes to certain registers will require synchronization between the clock domains.

The USB module requires a GCLK\_USB of 48 MHz  $\pm$  0.25% clock for low speed and full speed operation. To follow the USB data rate at 12 Mbit/s in full-speed mode, the CLK\_USB\_AHB clock should be at minimum 8 MHz. The GCLK\_USB clock is generated by the DFLL48 using a reference clock. When the USB is disabled, the GCLK used as DFLL reference should be disabled.

### 40.5.4 DMA

The USB has a built-in Direct Memory Access (DMA) and will read/write data to/from the system RAM when a USB transaction takes place. No CPU or DMA Controller resources are required.

### 40.5.5 Debug Operation

When the CPU is halted in debug mode the USB peripheral continues normal operation. If the USB peripheral is configured in a way that requires it to be periodically serviced by the CPU through interrupts or similar, improper operation or data loss may result during debugging.

### 40.5.6 Register Access Protection

Registers with write access can be optionally write-protected by the [Peripheral Access Controller \(PAC\)](#), except for the following:

- Device Interrupt Flag (INTFLAG) register
- Endpoint Interrupt Flag (EPINTFLAG) register
- Host Interrupt Flag (INTFLAG) register
- Pipe Interrupt Flag (PINTFLAG) register

**Note:** Optional write protection is indicated by the "PAC Write Protection" property in the register description.

Write protection does not apply for accesses through an external debugger.

### 40.5.7 Calibration

The output drivers for the DP/DM USB line interface can be fine tuned with calibration values from production tests. The calibration values must be loaded from the NVM Software Calibration Area into the USB Pad Calibration register (PADCAL) by software, before enabling the USB, to achieve the specified accuracy. Refer to [NVM Software Calibration Area Mapping](#) for further details.

For additional information on Pad Calibration, refer to the Pad Calibration ([PADCAL](#)) register.

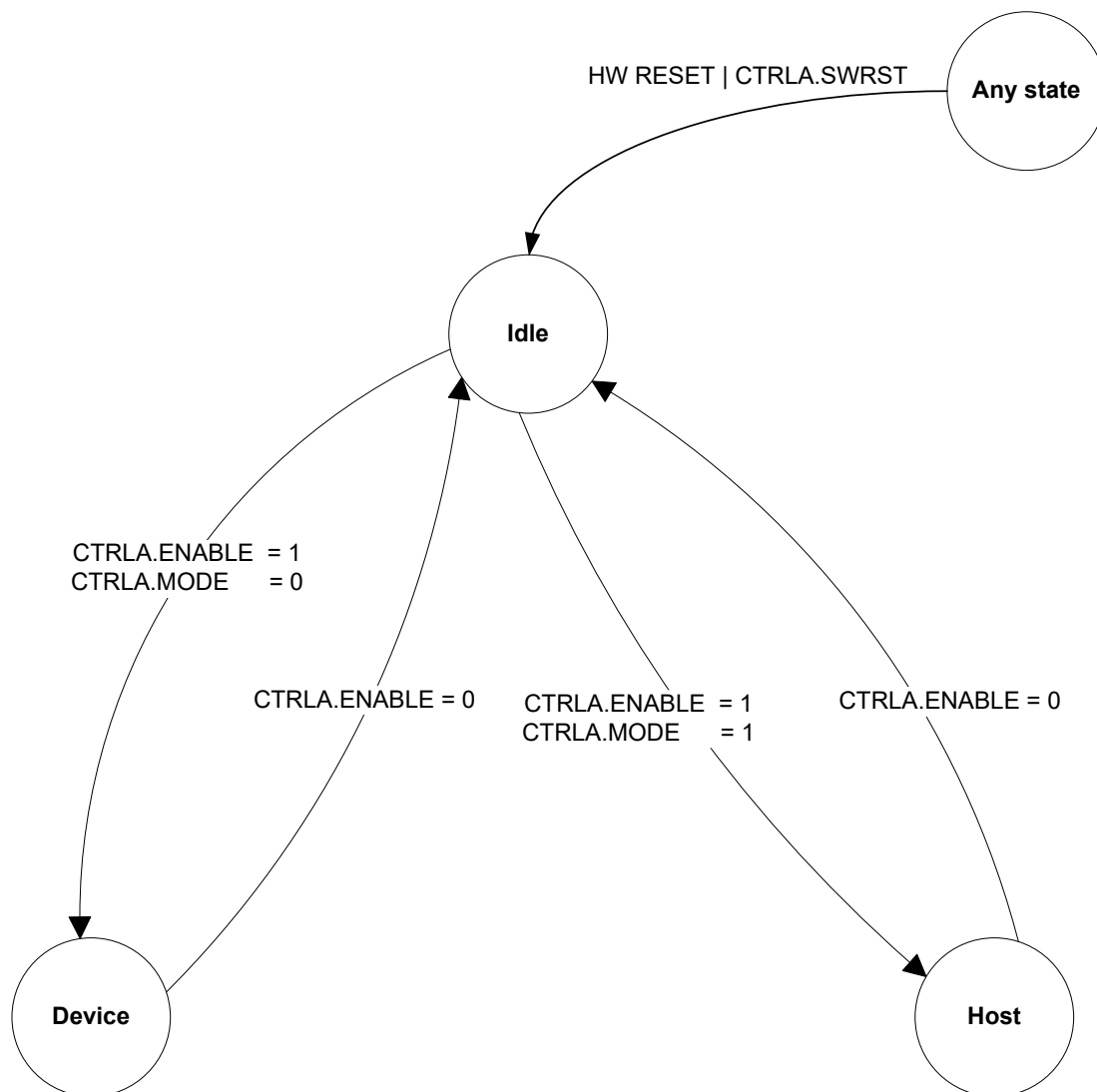
## 40.6 Functional Description

### 40.6.1 USB General Operation

#### 40.6.1.1 Initialization

After a hardware reset, the USB is disabled. The user should first enable the USB (CTRLA.ENABLE) in either device mode or host mode (CTRLA.MODE).

**Figure 40-2.** General States



After a hardware reset, the USB is in the idle state. In this state:

- The module is disabled. The USB Enable bit in the Control A register (CTRLA.ENABLE) is reset.
- The module clock is stopped in order to minimize power consumption.
- The USB pad is in suspend mode.
- The internal states and registers of the device and host are reset.

Before using the USB, the Pad Calibration register (PADCAL) must be loaded with production calibration values from the [NVM Software Calibration Area](#).

The USB is enabled by writing a '1' to CTRLA.ENABLE. The USB is disabled by writing a '0' to CTRLA.ENABLE.

The USB is reset by writing a '1' to the Software Reset bit in CTRLA (CTRLA.SWRST). All registers in the USB will be reset to their initial state, and the USB will be disabled. Refer to the CTRLA register for details.

The user can configure pads and speed before enabling the USB by writing to the Operating Mode bit in the Control A register (CTRLA.MODE) and the Speed Configuration field in the Control B register (CTRLB.SPDCONF). These values are taken into account once the USB has been enabled by writing a '1' to CTRLA.ENABLE.

After writing a '1' to CTRLA.ENABLE, the USB enters device mode or host mode (according to CTRLA.MODE).

The USB can be disabled at any time by writing a '0' to CTRLA.ENABLE.

Refer to [40.6.2. USB Device Operations](#) for the basic operation of the device mode.

Refer to [40.6.3. Host Operations](#) for the basic operation of the host mode.

## 40.6.2 USB Device Operations

This section gives an overview of the USB module device operation during normal transactions. For more details on general USB and USB protocol, refer to the Universal Serial Bus specification revision 2.1.

### 40.6.2.1 Initialization

To attach the USB device to start the USB communications from the USB host, a zero should be written to the Detach bit in the Device Control B register (CTRLB.DETACH). To detach the device from the USB host, a one must be written to the CTRLB.DETACH.

After the device is attached, the host will request the USB device descriptor using the default device address zero. On successful transmission, it will send a USB reset. After that, it sends an address to be configured for the device. All further transactions will be directed to this device address. This address should be configured in the Device Address field in the Device Address register (DADD.DADD) and the Address Enable bit in DADD (DADD.ADDEN) should be written to one to accept communications directed to this address. DADD.ADDEN is automatically cleared on receiving a USB reset.

### 40.6.2.2 Endpoint Configuration

Endpoint data can be placed anywhere in the device RAM. The USB controller accesses these endpoints directly through the AHB Host (built-in DMA) with the help of the endpoint descriptors. The base address of the endpoint descriptors needs to be written in the Descriptor Address register (DESCADD) by the user. For additional information, refer to Endpoint Description Structure.

Before using an endpoint, the user should configure the direction and type of the endpoint in Type of Endpoint field in the Device Endpoint Configuration register (EPCFG.EPTYPE0/1). The endpoint descriptor registers should be initialized to known values before using the endpoint, so that the USB controller does not read random values from the RAM.

The Endpoint Size field in the Packet Size register (PCKSIZE.SIZE) should be configured as per the size reported to the host for that endpoint. The Address of Data Buffer register (ADDR) should be set to the data buffer used for endpoint transfers.

The RAM Access Interrupt bit in Device Interrupt Flag register (INTFLAG.RAMACER) is set when a RAM access underflow error occurs during IN data stage.

When an endpoint is disabled, the following registers are cleared for that endpoint:

- Device Endpoint Interrupt Enable Clear/Set (EPINTENCLR/SET) register
- Device Endpoint Interrupt Flag (EPINTFLAG) register

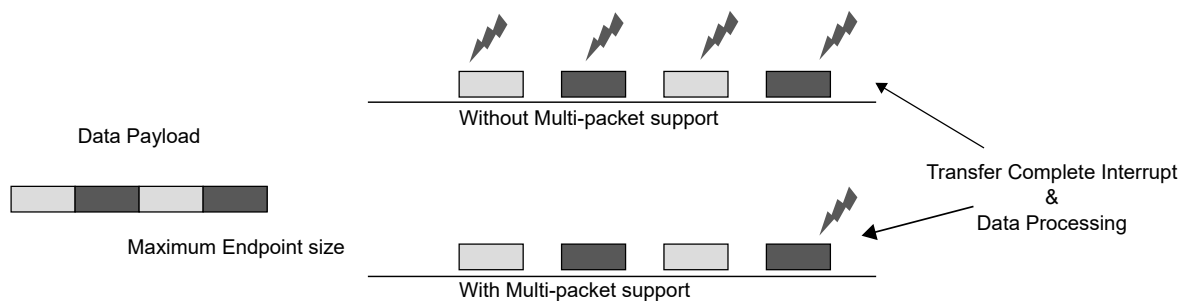
- Transmit Stall 0 bit in the Endpoint Status register (EPSTATUS.STALLRQ0)
- Transmit Stall 1 bit in the Endpoint Status register (EPSTATUS.STALLRQ1)

### 40.6.2.3 Multi-Packet Transfers

Multi-packet transfer enables a data payload exceeding the endpoint maximum transfer size to be transferred as multiple packets without software intervention. This reduces the number of interrupts and software intervention required to manage higher level USB transfers. Multi-packet transfer is identical to the IN and OUT transactions described below unless otherwise noted in this section.

The application software provides the size and address of the RAM buffer to be proceeded by the USB module for a specific endpoint, and the USB module will split the buffer in the required USB data transfers without any software intervention.

**Figure 40-3.** Multi-Packet Feature - Reduction of CPU Overhead



### 40.6.2.4 USB Reset

The USB bus reset is initiated by a connected host and managed by hardware.

During USB reset the following registers are cleared:

- Device Endpoint Configuration (EPCFG) register - except for Endpoint 0
- Device Frame Number (FNUM) register
- Device Address (DADD) register
- Device Endpoint Interrupt Enable Clear/Set (EPINTENCLR/SET) register
- Device Endpoint Interrupt Flag (EPINTFLAG) register
- Transmit Stall 0 bit in the Endpoint Status register (EPSTATUS.STALLRQ0)
- Transmit Stall 1 bit in the Endpoint Status register (EPSTATUS.STALLRQ1)
- Endpoint Interrupt Summary (EPINTSMRY) register
- Upstream resume bit in the Control B register (CTRLB.UPRSM)

At the end of the reset process, the End of Reset bit is set in the Interrupt Flag register (INTFLAG.EORST).

### 40.6.2.5 Start-of-Frame

When a Start-of-Frame (SOF) token is detected, the frame number from the token is stored in the Frame Number field in the Device Frame Number register (FNUM.FNUM), and the Start-of-Frame interrupt bit in the Device Interrupt Flag register (INTFLAG.SOF) is set. If there is a CRC or bit-stuff error, the Frame Number Error status flag (FNUM.FNCERR) in the FNUM register is set.

#### 40.6.2.6 Management of SETUP Transactions

When a SETUP token is detected and the device address of the token packet does not match DADD.DADD, the packet is discarded and the USB module returns to idle and waits for the next token packet.

When the address matches, the USB module checks if the endpoint is enabled in EPCFG. If the addressed endpoint is disabled, the packet is discarded and the USB module returns to idle and waits for the next token packet.

When the endpoint is enabled, the USB module then checks on the EPCFG of the addressed endpoint. If the EPCFG.EPTYPE0 is not set to control, the USB module returns to idle and waits for the next token packet.

When the EPCFG.EPTYPE0 matches, the USB module then fetches the Data Buffer Address (ADDR) from the addressed endpoint's descriptor and waits for a DATA0 packet. If a PID error or any other PID than DATA0 is detected, the USB module returns to idle and waits for the next token packet.

When the data PID matches and if the Received Setup Complete interrupt bit in the Device Endpoint Interrupt Flag register (EPINTFLAG.RXSTP) is equal to zero, ignoring the Bank 0 Ready bit in the Device Endpoint Status register (EPSTATUS.BKORDY), the incoming data is written to the data buffer pointed to by the Data Buffer Address (ADDR). If the number of received data bytes exceeds the endpoint's maximum data payload size as specified by the PCKSIZE.SIZE, the remainders of the received data bytes are discarded. The packet will still be checked for bit-stuff and CRC errors. Software must never report a endpoint size to the host that is greater than the value configured in PCKSIZE.SIZE. If a bit-stuff or CRC error is detected in the packet, the USB module returns to idle and waits for the next token packet.

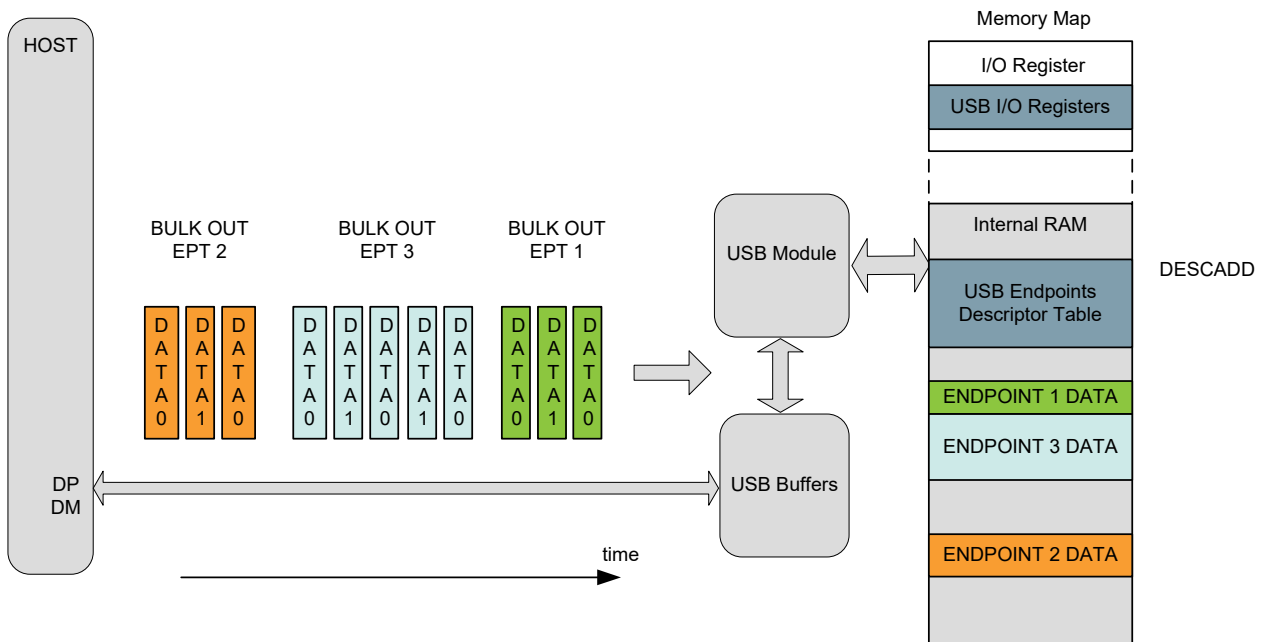
If data is successfully received, an ACK handshake is returned to the host, and the number of received data bytes, excluding the CRC, is written to the Byte Count (PCKSIZE.BYTE\_COUNT). If the number of received data bytes is the maximum data payload specified by PCKSIZE.SIZE, no CRC data is written to the data buffer. If the number of received data bytes is the maximum data payload specified by PCKSIZE.SIZE minus one, only the first CRC data is written to the data buffer. If the number of received data is equal or less than the data payload specified by PCKSIZE.SIZE minus two, both CRC data bytes are written to the data buffer.

Finally the EPSTATUS is updated. Data Toggle OUT bit (EPSTATUS.DTGLOUT), the Data Toggle IN bit (EPSTATUS.DTGLIN), the current bank bit (EPSTATUS.CURRBK) and the Bank Ready 0 bit (EPSTATUS.BKORDY) are set. Bank Ready 1 bit (EPSTATUS.BK1RDY) and the Stall Bank 0/1 bit (EPSTATUS.STALLQR0/1) are cleared on receiving the SETUP request. The RXSTP bit is set and triggers an interrupt if the Received Setup Interrupt Enable bit is set in Endpoint Interrupt Enable Set/Clear register (EPINTENSET/CLR.RXSTP).



## 40.6.2.7 Management of OUT Transactions

Figure 40-4. OUT Transfer: Data Packet Host to USB Device



When an OUT token is detected, and the device address of the token packet does not match DADD.DADD, the packet is discarded and the USB module returns to idle and waits for the next token packet.

If the address matches, the USB module checks if the endpoint number received is enabled in the EPCFG of the addressed endpoint. If the addressed endpoint is disabled, the packet is discarded and the USB module returns to idle and waits for the next token packet.

When the endpoint is enabled, the USB module then checks the Endpoint Configuration register (EPCFG) of the addressed output endpoint. If the type of the endpoint (EPCFG.EPTYPE0) is not set to OUT, the USB module returns to idle and waits for the next token packet.

The USB module then fetches the Data Buffer Address (ADDR) from the addressed endpoint's descriptor, and waits for a DATA0 or DATA1 packet. If a PID error or any other PID than DATA0 or DATA1 is detected, the USB module returns to idle and waits for the next token packet.

If EPSTATUS.STALLRQ0 in EPSTATUS is set, the incoming data is discarded. If the endpoint is not isochronous, a STALL handshake is returned to the host and the Transmit Stall Bank 0 interrupt bit in EPINTFLAG (EPINTFLAG.STALL0) is set.

For isochronous endpoints, data from both a DATA0 and DATA1 packet will be accepted. For other endpoint types the PID is checked against EPSTATUS.DTGLOUT. If a PID mismatch occurs, the incoming data is discarded, and an ACK handshake is returned to the host.

If EPSTATUS.BK0RDY is set, the incoming data is discarded, the bit Transmit Fail 0 interrupt bit in EPINTFLAG (EPINTFLAG.TRFAIL0) and the status bit STATUS\_BK.ERRORFLOW are set. If the endpoint is not isochronous, a NAK handshake is returned to the host.

The incoming data is written to the data buffer pointed to by the Data Buffer Address (ADDR). If the number of received data bytes exceeds the maximum data payload specified as PCKSIZE.SIZE, the remainders of the received data bytes are discarded. The packet will still be checked for bit-stuff and CRC errors. If a bit-stuff or CRC error is detected in the packet, the USB module returns to idle and waits for the next token packet.

If the endpoint is isochronous and a bit-stuff or CRC error in the incoming data, the number of received data bytes, excluding CRC, is written to PCKSIZE.BYTE\_COUNT. Finally the EPINTFLAG.TRFAIL0 and CRC Error bit in the Device Bank Status register (STATUS\_BK.CRCERR) is set for the addressed endpoint.

If data was successfully received, an ACK handshake is returned to the host if the endpoint is not isochronous, and the number of received data bytes, excluding CRC, is written to PCKSIZE.BYTE\_COUNT. If the number of received data bytes is the maximum data payload specified by PCKSIZE.SIZE no CRC data bytes are written to the data buffer. If the number of received data bytes is the maximum data payload specified by PCKSIZE.SIZE minus one, only the first CRC data byte is written to the data buffer. If the number of received data is equal or less than the data payload specified by PCKSIZE.SIZE minus two, both CRC data bytes are written to the data buffer.

Finally in EPSTATUS for the addressed output endpoint, EPSTATUS.BK0RDY is set and EPSTATUS.DTGLOUT is toggled if the endpoint is not isochronous. The flag Transmit Complete 0 interrupt bit in EPINTFLAG (EPINTFLAG.TRCPT0) is set for the addressed endpoint.

#### 40.6.2.8 Multi-Packet Transfers for OUT Endpoint

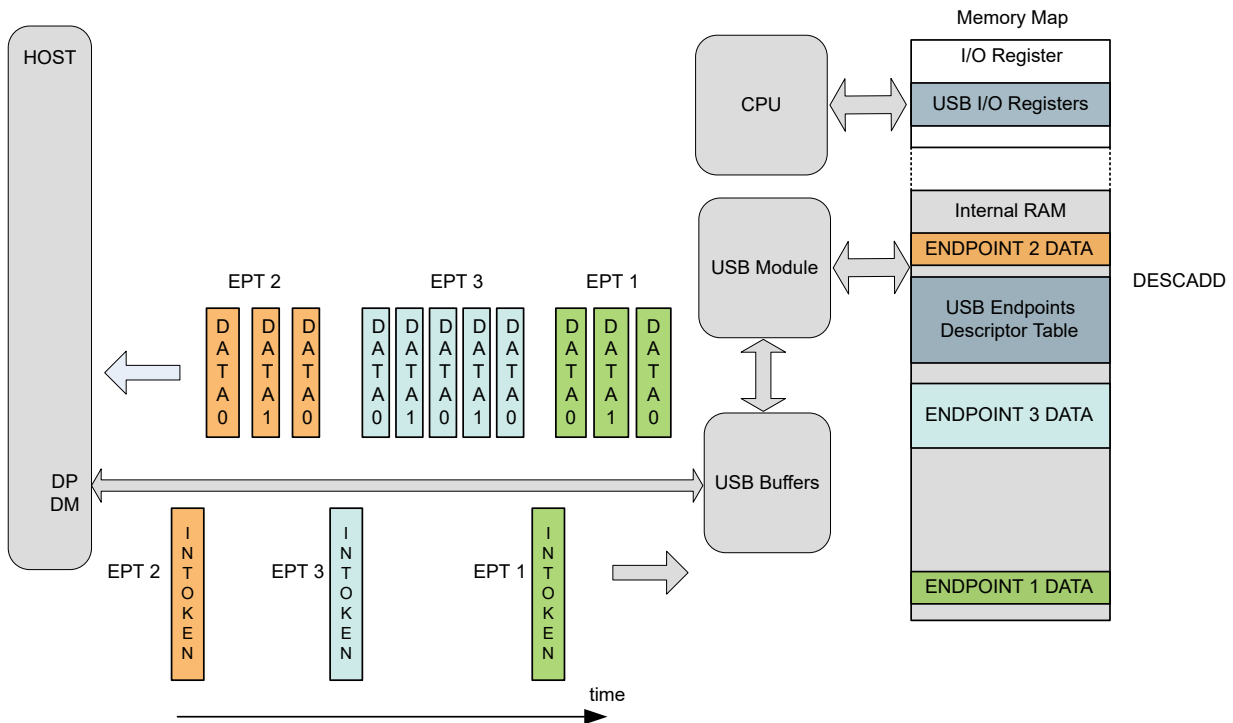
The number of data bytes received is stored in endpoint PCKSIZE.BYTE\_COUNT as for normal operation. Since PCKSIZE.BYTE\_COUNT is updated after each transaction, it must be set to zero when setting up a new transfer. The total number of bytes to be received must be written to PCKSIZE.MULTI\_PACKET\_SIZE. This value must be a multiple of PCKSIZE.SIZE, otherwise excess data may be written to SRAM locations used by other parts of the application.

EPSTATUS.DTGLOUT management for non-isochronous packets and EPINTFLAG.BK1RDY/BK0RDY management are as for normal operation.

If a maximum payload size packet is received, PCKSIZE.BYTE\_COUNT will be incremented by PCKSIZE.SIZE after the transaction has completed, and EPSTATUS.DTGLOUT will be toggled if the endpoint is not isochronous. If the updated PCKSIZE.BYTE\_COUNT is equal to PCKSIZE.MULTI\_PACKET\_SIZE (i.e. the last transaction), EPSTATUS.BK1RDY/BK0RDY, and EPINTFLAG.TRCPT0/TRCPT1 will be set.

### 40.6.2.9 Management of IN Transactions

Figure 40-5. IN Transfer: Data Packet USB Device to Host After Request from Host



When an IN token is detected, and if the device address of the token packet does not match DADD.DADD, the packet is discarded and the USB module returns to idle and waits for the next token packet.

When the address matches, the USB module checks if the endpoint received is enabled in the EPCFG of the addressed endpoint and if not, the packet is discarded and the USB module returns to idle and waits for the next token packet.

When the endpoint is enabled, the USB module then checks on the EPCFG of the addressed input endpoint. If the EPCFG.EPTYPE1 is not set to IN, the USB module returns to idle and waits for the next token packet.

If EPSTATUS.STALLRQ1 in EPSTATUS is set, and the endpoint is not isochronous, a STALL handshake is returned to the host and EPINTFLAG.STALL1 is set.

If EPSTATUS.BK1RDY is cleared, the flag EPINTFLAG.TRFAIL1 is set. If the endpoint is not isochronous, a NAK handshake is returned to the host.

The USB module then fetches the Data Buffer Address (ADDR) from the addressed endpoint's descriptor. The data pointed to by the Data Buffer Address (ADDR) is sent to the host in a DATA0 packet if the endpoint is isochronous. For non-isochronous endpoints a DATA0 or DATA1 packet is sent depending on the state of EPSTATUS.DTGLIN. When the number of data bytes specified in endpoint PCKSIZE.BYTE\_COUNT is sent, the CRC is appended and sent to the host.

For isochronous endpoints, EPSTATUS.BK1RDY is cleared and EPINTFLAG.TRCPT1 is set.

For all non-isochronous endpoints the USB module waits for an ACK handshake from the host. If an ACK handshake is not received within 16 bit times, the USB module returns to idle and waits for the next token packet. If an ACK handshake is successfully received EPSTATUS.BK1RDY is cleared, EPINTFLAG.TRCPT1 is set and EPSTATUS.DTGLIN is toggled.

#### 40.6.2.10 Multi-Packet Transfers for IN Endpoint

The total number of data bytes to be sent is written to PCKSIZE.BYTE\_COUNT as for normal operation. The Multi-packet size register (PCKSIZE.MULTI\_PACKET\_SIZE) is used to store the number of bytes that are sent, and must be written to zero when setting up a new transfer.

When an IN token is received, PCKSIZE.BYTE\_COUNT and PCKSIZE.MULTI\_PACKET\_SIZE are fetched. If PCKSIZE.BYTE\_COUNT minus PCKSIZE.MULTI\_PACKET\_SIZE is less than the endpoint PCKSIZE.SIZE, endpoint BYTE\_COUNT minus endpoint PCKSIZE.MULTI\_PACKET\_SIZE bytes are transmitted, otherwise PCKSIZE.SIZE number of bytes are transmitted. If endpoint PCKSIZE.BYTE\_COUNT is a multiple of PCKSIZE.SIZE, the last packet sent will be zero-length if the AUTOZLP bit is set.

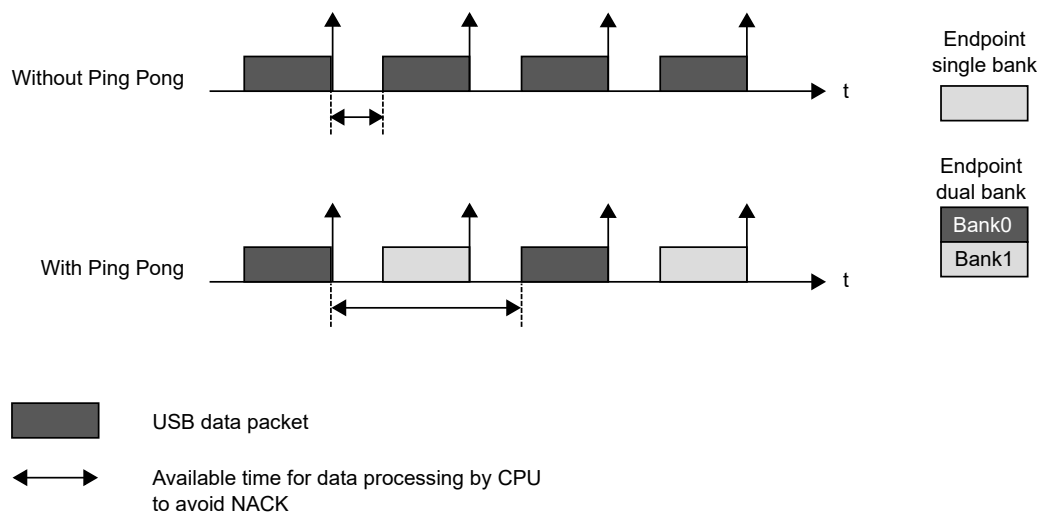
If a maximum payload size packet was sent (i.e. not the last transaction), MULTI\_PACKET\_SIZE will be incremented by the PCKSIZE.SIZE. If the endpoint is not isochronous the EPSTATUS.DTGLIN bit will be toggled when the transaction has completed. If a short packet was sent (i.e. the last transaction), MULTI\_PACKET\_SIZE is incremented by the data payload. EPSTATUS.BK0/1RDY will be cleared and EPINTFLAG.TRCPT0/1 will be set.

#### 40.6.2.11 Ping-Pong Operation

When an endpoint is configured for ping-pong operation, it uses both the input and output data buffers (banks) for a given endpoint in a single direction. The direction is selected by enabling one of the IN or OUT direction in EPCFG.EPTYPE0/1 and configuring the opposite direction in EPCFG.EPTYPE1/0 as Dual Bank.

When ping-pong operation is enabled for an endpoint, the endpoint in the opposite direction must be configured as dual bank. The data buffer, data address pointer and byte counter from the enabled endpoint are used as Bank 0, while the matching registers from the disabled endpoint are used as Bank 1.

Figure 40-6. Ping-Pong Overview



The Bank Select flag in EPSTATUS.CURBK indicates which bank data will be used in the next transaction, and is updated after each transaction. According to EPSTATUS.CURBK, EPINTFLAG.TRCPT0 or EPINTFLAG.TRFAIL0 or EPINTFLAG.TRCPT1 or EPINTFLAG.TRFAIL1 in

EPINTFLAG and Data Buffer 0/1 ready (EPSTATUS.BK0RDY and EPSTATUS.BK1RDY) are set. The EPSTATUS.DTGLOUT and EPSTATUS.DTGLIN are updated for the enabled endpoint direction only.

#### 40.6.2.12 Feedback Operation

Feedback endpoints are endpoints with same the address but in different directions. This is usually used in explicit feedback mechanism in USB Audio, where a feedback endpoint is associated to one or more isochronous data endpoints to which it provides feedback service. The feedback endpoint always has the opposite direction from the data endpoint.

The feedback endpoint always has the opposite direction from the data endpoint(s). The feedback endpoint has the same endpoint number as the first (lower) data endpoint. A feedback endpoint can be created by configuring an endpoint with different endpoint size (PCKSIZE.SIZE) and different endpoint type (EPCFG.EPTYPE0/1) for the IN and OUT direction.

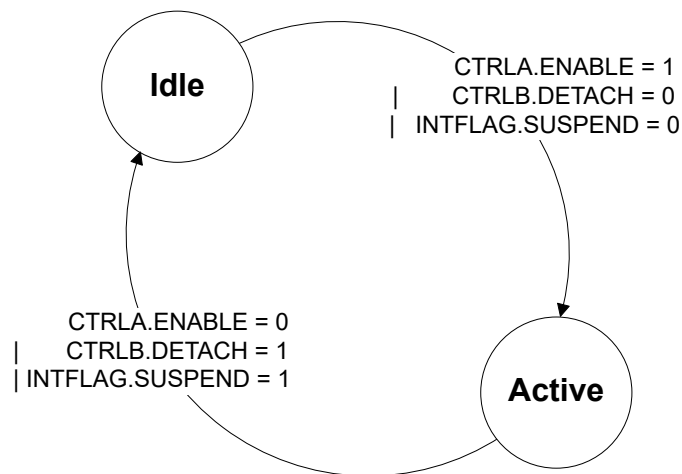
Example Configuration for Feedback Operation:

- Endpoint n / IN: EPCFG.EPTYPE1 = Interrupt IN, PCKSIZE.SIZE = 64.
- Endpoint n / OUT: EPCFG.EPTYPE0= Isochronous OUT, PCKSIZE.SIZE = 512.

#### 40.6.2.13 Suspend State and Pad Behavior

The following figure, Pad Behavior, illustrates the behavior of the USB pad in Device mode.

Figure 40-7. Pad Behavior

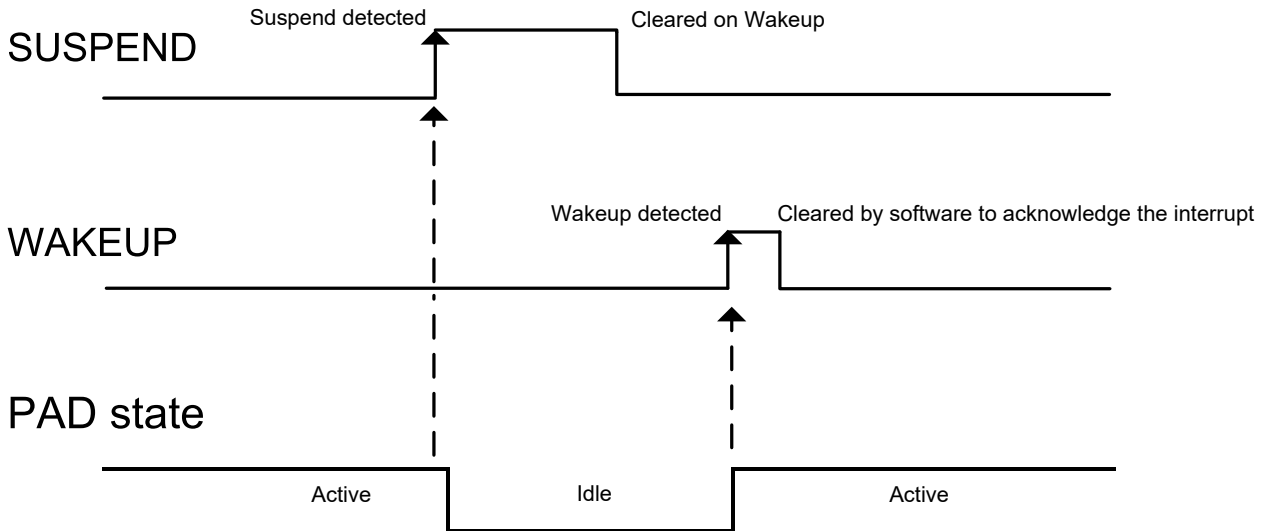


In Idle state, the pad is in Low Power Consumption mode.

In Active state, the pad is active.

The following figure, Pad Events, illustrates the pad events leading to a PAD state change.

**Figure 40-8. Pad Events**



The Suspend Interrupt bit in the Device Interrupt Flag register (INTFLAG.SUSPEND) is set when a USB Suspend state has been detected on the USB bus. The USB pad is then automatically put in the Idle state. The detection of a non-idle state sets the Wake Up Interrupt bit (INTFLAG.WAKEUP) and wakes the USB pad.

The pad goes to the Idle state if the USB module is disabled or if CTRLB.DETACH is written to one. It returns to the Active state when CTRLA.ENABLE is written to one and CTRLB.DETACH is written to zero.

#### 40.6.2.14 Remote Wakeup

The remote wakeup request (also known as upstream resume) is the only request the device may send on its own initiative. This should be preceded by a DEVICE\_REMOTE\_WAKEUP request from the host.

First, the USB must have detected a "Suspend" state on the bus, i.e. the remote wakeup request can only be sent after INTFLAG.SUSPEND has been set.

The user may then write a one to the Remote Wakeup bit (CTRLB.UPRSM) to send an Upstream Resume to the host initiating the wakeup. This will automatically be done by the controller after 5 ms of inactivity on the USB bus.

When the controller sends the Upstream Resume INTFLAG.WAKEUP is set and INTFLAG.SUSPEND is cleared.

The CTRLB.UPRSM is cleared at the end of the transmitting Upstream Resume.

In case of a rebroadcast resume initiated by the host, the End of Resume bit (INTFLAG.EORSM) flag is set when the rebroadcast resume is completed.

In the case where the CTRLB.UPRSM bit is set while a host initiated downstream resume is already started, the CTRLB.UPRSM is cleared and the upstream resume request is ignored.

#### 40.6.2.15 Link Power Management L1 (LPM-L1) Suspend State Entry and Exit as Device

The LPM Handshake bit in CTRLB.LPMHDSK should be configured to accept the LPM transaction.

When a LPM transaction is received on any enabled endpoint *n* and a handshake has been sent in response by the controller according to CTRLB.LPMHDSK, the Device Link Power Manager (EXTREG) register is updated in the bank 0 of the addressed endpoint's descriptor. It contains information such as the Best Effort Service Latency (BESL), the Remote Wake bit (bRemoteWake), and the Link State parameter (bLinkState). Usually, the LPM transaction uses only the endpoint number 0.

If the LPM transaction was positively acknowledged (ACK handshake), USB sets the Link Power Management Interrupt bit (INTFLAG.LPMSUSP) bit which indicates that the USB transceiver is suspended, reducing power consumption. This suspend occurs 9 microseconds after the LPM transaction according to the specification.

To further reduce consumption, it is recommended to stop the USB clock while the device is suspended.

The MCU can also enter in one of the available sleep modes if the wakeup time latency of the selected sleep mode complies with the host latency constraint, refer to the BESL parameter in EXTREG register.

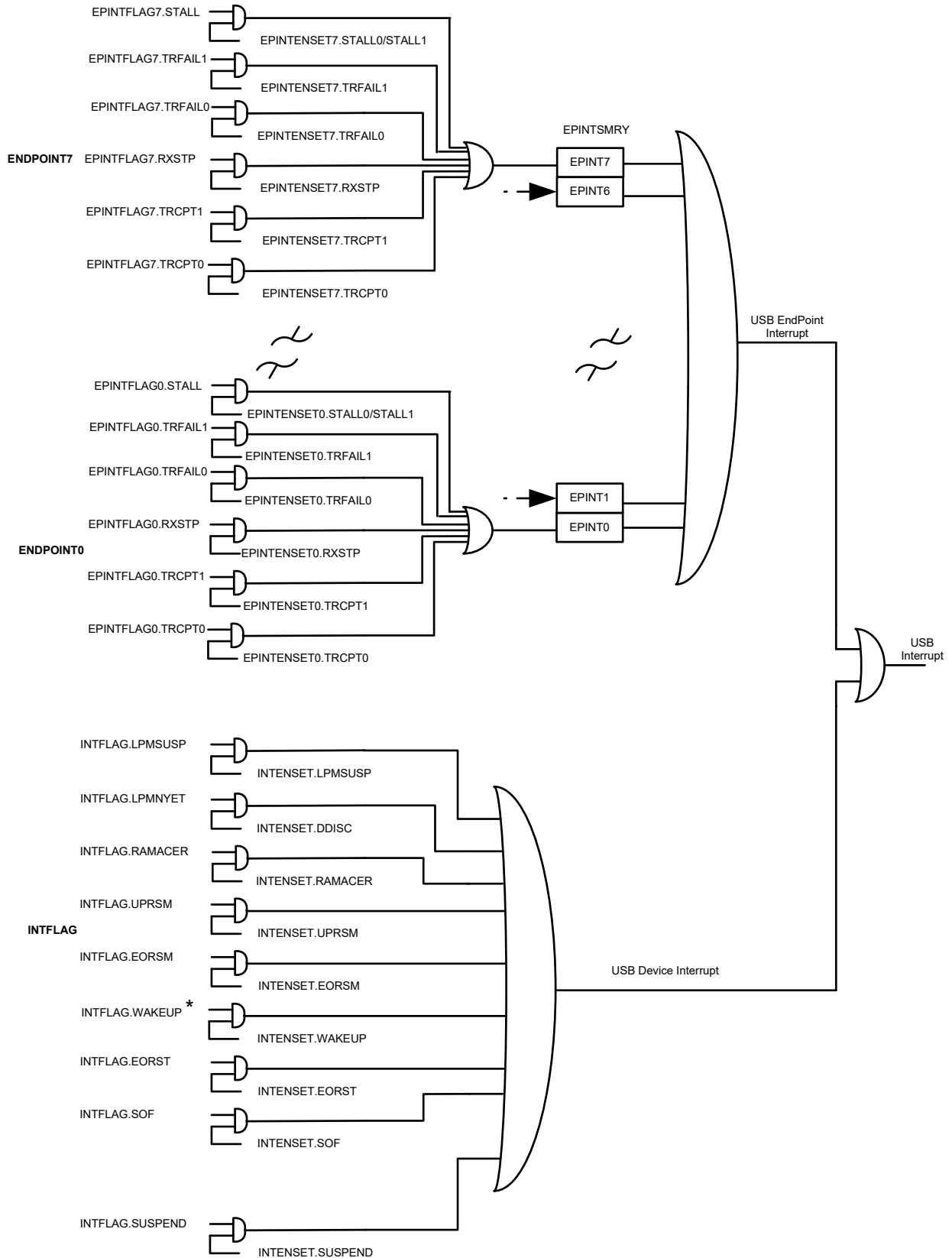
Recovering from this LPM-L1 suspend state is exactly the same as the Suspend state (see Section [40.6.2.13. Suspend State and Pad Behavior](#)) except that the remote wakeup duration initiated by USB is shorter to comply with the Link Power Management specification.

If the LPM transaction is responded with a NYET, the Link Power Management Not Yet Interrupt Flag (INTFLAG.LPMNYET) is set. This generates an interrupt if the Link Power Management Not Yet Interrupt Enable bit (INTENCLR/SET.LPMNYET) is set.

If the LPM transaction is responded with a STALL or no handshake, no flag is set, and the transaction is ignored.

### 40.6.2.16 USB Device Interrupt

Figure 40-9. Device Interrupt



\* Asynchronous interrupt



The WAKEUP is an asynchronous interrupt and can be used to wake-up the device from any sleep mode.

### 40.6.3 Host Operations

This section gives an overview of the USB module Host operation during normal transactions. For more details on general USB and USB protocol, refer to Universal Serial Bus Specification revision 2.1.

#### 40.6.3.1 Device Detection and Disconnection

Prior to device detection the software must set the VBUS is OK bit (CTRLB.VBUSOK) register when the VBUS is available. This notifies the USB host that USB operations can be started. When the bit CTRLB.VBUSOK is zero and even if the USB HOST is configured and enabled, host operation is halted. Setting the bit CTRLB.VBUSOK will allow host operation when the USB is configured.

The Device detection is managed by the software using the Line State field in the Host Status (STATUS.LINESTATE) register. The device connection is detected by the host controller when DP or DM is pulled high, depending of the speed of the device.

The device disconnection is detected by the host controller when both DP and DM are pulled down using the STATUS.LINESTATE registers.

The Device Connection Interrupt bit (INTFLAG.DCONN) is set if a device connection is detected.

The Device Disconnection Interrupt bit (INTFLAG.DDISC) is set if a device disconnection is detected.

#### 40.6.3.2 Host Terminology

In host mode, the term pipe is used instead of endpoint. A host pipe corresponds to a device endpoint, refer to "Universal Serial Bus Specification revision 2.1." for more information.

#### 40.6.3.3 USB Reset

The USB sends a USB reset signal when the user writes a one to the USB Reset bit (CTRLB.BUSRESET). When the USB reset has been sent, the USB Reset Sent Interrupt bit in the INTFLAG (INTFLAG.RST) is set and all pipes will be disabled.

If the bus was previously in a suspended state (i.e., the Start of Frame Generation Enable bit (CTRLB.SOFE) is zero), the USB will switch it to the Resume state, causing the bus to asynchronously set the Host Wakeup Interrupt flag (INTFLAG.WAKEUP). The CTRLB.SOFE bit will be set in order to generate SOFs immediately after the USB reset.

During USB reset the following registers are cleared:

- All Host Pipe Configuration register (PCFG)
- Host Frame Number register (FNUM)
- Interval for the Bulk-Out/Ping transaction register (BINTERVAL)
- Host Start-of-Frame Control register (HSOFC)
- Pipe Interrupt Enable Clear/Set register (PINTENCLR/SET)
- Pipe Interrupt Flag register (PINTFLAG)
- Pipe Freeze bit in Pipe Status register (PSTATUS.FREEZE)

After the reset the user should check the Speed Status field in the Status register (STATUS.SPEED) to find out the current speed according to the capability of the peripheral.

#### 40.6.3.4 Pipe Configuration

Pipe data can be placed anywhere in the RAM. The USB controller accesses these pipes directly through the AHB host (built-in DMA) with the help of the pipe descriptors. The base address of the pipe descriptors needs to be written in the Descriptor Address register (DESCADD) by the user. Refer to Pipe Description Structure.

Before using a pipe, the user should configure the direction and type of the pipe in Type of Pipe field in the Host Pipe Configuration register (PCFG.PTYPE). The pipe descriptor registers should be initialized to known values before using the pipe, so that the USB controller does not read the random values from the RAM.

The Pipe Size field in the Packet Size register (PCKSIZE.SIZE) should be configured as per the size reported by the device for the endpoint associated with this pipe. The Address of Data Buffer register (ADDR) should be set to the data buffer used for pipe transfers.

The Pipe Bank bit (PCFG.BK) should be set to one if dual banking is desired. Dual bank is not supported for Control pipes.

The Ram Access Interrupt bit in Host Interrupt Flag register (INTFLAG.RAMACER) is set when a RAM access underflow error occurs during an OUT stage.

When a pipe is disabled, the following registers are cleared for that pipe:

- Interval for the Bulk-Out/Ping transaction register (BINTERVAL)
- Pipe Interrupt Enable Clear/Set register (PINTENCLR/SET)
- Pipe Interrupt Flag register (PINTFLAG)
- Pipe Freeze bit in Pipe Status register (PSTATUS.FREEZE)

#### 40.6.3.5 Pipe Activation

A disabled pipe is inactive, and will be reset along with its context registers (pipe registers for the pipe n). Pipes are enabled by writing the Type of the Pipe bit (PCFG.PTYPE) to a value different than 0x0 (disabled).

When a pipe is enabled, the Pipe Freeze bit in the Pipe Status register (PSTATUS.FREEZE) is set. This allows the user to complete the configuration of the pipe, without starting a USB transfer.

When starting an enumeration, the user retrieves the device descriptor by sending a GET\_DESCRIPTOR USB request. This descriptor contains the maximal packet size of the device default control endpoint (bMaxPacketSize0), which the user should use to reconfigure the size of the default control pipe.

#### 40.6.3.6 Pipe Address Setup

Once the device has answered the first host requests with the default device address 0, the host assigns a new address to the device. The host controller has to send a USB reset to the device and a SET\_ADDRESS(addr) SETUP request with the new address to be used by the device. Once this SETUP transaction is complete, the user writes the new address to the Pipe Device Address field in the Host Control Pipe register (CTRL\_PIPE.PDADDR) in Pipe descriptor. All following requests by this pipe will be performed using this new address.

#### 40.6.3.7 Suspend and Wakeup

Setting CTRLB.SOFE to zero when in host mode will cause the USB to cease sending Start-of-Frames on the USB bus and enter the Suspend state. The USB device will enter the Suspend state 3ms later.

Before entering suspend by writing CTRLB.SOFE to zero, the user must freeze the active pipes by setting their PSTATUS.FREEZE bit. Any current on-going pipe will complete its transaction, and then all pipes will be inactive. The user should wait at least 1 complete frame before entering the suspend mode to avoid any data loss.

The device can awaken the host by sending an Upstream Resume (Remote Wakeup feature). When the host detects a non-idle state on the USB bus, it sets the INTFLAG.WAKEUP. If the non-idle bus state corresponds to an Upstream Resume (K state), the Upstream Resume Received Interrupt bit in INTFLAG (INTFLAG.UPRSM) is set and the user must generate a Downstream Resume within 1 ms and for at least 20 ms. It is required to first write a one to the Send USB Resume bit in CTRLB (CTRLB.RESUME) to respond to the upstream resume with a downstream resume. Alternatively, the host can resume from a suspend state by sending a Downstream Resume on the

USB bus (CTRLB.RESUME set to 1). In both cases, when the downstream resume is completed, the CTRLB.SOFE bit is automatically set and the host enters again the active state.

#### 40.6.3.8 Phase-locked SOFs

To support the Synchronous Endpoints capability, the period of the emitted Start-of-Frame is maintained while the USB connection is not in the active state. This does not apply for the disconnected/connected/reset states. It applies for active/idle/suspend/resume states. The period of Start-of-Frame will be 1ms when the USB connection is in active state and an integer number of milli-seconds across idle/suspend/resume states.

To ensure the Synchronous Endpoints capability, the GCLK\_USB clock must be kept running. If the GCLK\_USB is interrupted, the period of the emitted Start-of-Frame will be erratic.

#### 40.6.3.9 Management of Control Pipes

A control transaction is composed of three stages:

- SETUP
- Data (IN or OUT)
- Status (IN or OUT)

The user has to change the pipe token according to each stage using the Pipe Token field in PCFG (PCFG.PTOKEN).

For control pipes only, the token is assigned a specific initial data toggle sequence:

- SETUP: Data0
- IN: Data1
- OUT: Data1

#### 40.6.3.10 Management of IN Pipes

IN packets are sent by the USB device controller upon IN request reception from the host. All the received data from the device to the host will be stored in the bank provided the bank is empty. The pipe and its descriptor in RAM must be configured.

The host indicates it is able to receive data from the device by clearing the Bank 0/1 Ready bit in PSTATUS (PSTATUS.BK0/1RDY), which means that the memory for the bank is available for new USB transfer.

The USB will perform IN requests as long as the pipe is not frozen by the user.

The generation of IN requests starts when the pipe is unfrozen (PSTATUS.PFREEZE is set to zero).

When the current bank is full, the Transmit Complete 0/1 bit in PINTFLAG (PINTFLAG.TRCPT0/1) will be set and trigger an interrupt if enabled and the PSTATUS.BK0/1RDY bit will be set.

PINTFLAG.TRCPT0/1 must be cleared by software to acknowledge the interrupt. This is done by writing a one to the PINTFLAG.TRCPT0/1 of the addressed pipe.

The user reads the PCKSIZE.BYTE\_COUNT to know how many bytes should be read.

To free the bank the user must read the IN data from the address ADDR in the pipe descriptor and clear the PKSTATUS.BK0/1RDY bit. When the IN pipe is composed of multiple banks, a successful IN transaction will switch to the next bank. Another IN request will be performed by the host as long as the PSTATUS.BK0/1RDY bit for that bank is set. The PINTFLAG.TRCPT0/1 and PSTATUS.BK0/1RDY will be updated accordingly.

The user can follow the current bank looking at Current Bank bit in PSTATUS (PSTATUS.CURBK) and by looking at Data Toggle for IN pipe bit in PSTATUS (PSTATUS.DTGLIN).

When the pipe is configured as single bank (Pipe Bank bit in PCFG (PCFG.BK) is 0), only PINTFLAG.TRCPT0 and PSTATUS.BK0 are used. When the pipe is configured as dual bank (PCFG.BK is 1), both PINTFLAG.TRCPT0/1 and PSTATUS.BK0/1 are used.

#### 40.6.3.11 Management of OUT Pipes

OUT packets are sent by the host. All the data stored in the bank will be sent to the device provided the bank is filled. The pipe and its descriptor in RAM must be configured.

The host can send data to the device by writing to the data bank 0 in single bank or the data bank 0/1 in dual bank.

The generation of OUT packet starts when the pipe is unfrozen (PSTATUS.PFREEZE is zero).

The user writes the OUT data to the data buffer pointer by ADDR in the pipe descriptor and allows the USB to send the data by writing a one to the PSTATUS.BK0/1RDY. This will also cause a switch to the next bank if the OUT pipe is part of a dual bank configuration.

PINTFLAGn.TRCPT0/1 must be cleared before setting PSTATUS.BK0/1RDY to avoid missing an PINTFLAGn.TRCPT0/1 event.

#### 40.6.3.12 Alternate Pipe

The user has the possibility to run sequentially several logical pipes on the same physical pipe. It allows addressing of any device endpoint of any attached device on the bus.

Before switching pipe, the user should save the pipe context (Pipe registers and descriptor for pipe n).

After switching pipe, the user should restore the pipe context (Pipe registers and descriptor for pipe n) and in particular PCFG, and PSTATUS.

#### 40.6.3.13 Data Flow Error

This error exists only for isochronous and interrupt pipes for both IN and OUT directions. It sets the Transmit Fail bit in PINTFLAG (PINTFLAG.TRFAIL), which triggers an interrupt if the Transmit Fail bit in PINTENCLR/SET(PINTENCLR/SET.TRFAIL) is set. The user must check the Pipe Interrupt Summary register (PINTSMRY) to find out the pipe which triggered the interrupt. Then the user must check the origin of the interrupt's bank by looking at the Pipe Bank Status register (STATUS\_BK) for each bank. If the Error Flow bit in the STATUS\_BK (STATUS\_BK.ERRORFLOW) is set then the user is able to determine the origin of the data flow error. As the user knows that the endpoint is an IN or OUT the error flow can be deduced as OUT underflow or as an IN overflow.

An underflow can occur during an OUT stage if the host attempts to send data from an empty bank. If a new transaction is successful, the relevant bank descriptor STATUS\_BK.ERRORFLOW will be cleared.

An overflow can occur during an IN stage if the device tries to send a packet while the bank is full. Typically this occurs when a CPU is not fast enough. The packet data is not written to the bank and is lost. If a new transaction is successful, the relevant bank descriptor STATUS\_BK.ERRORFLOW will be cleared.

#### 40.6.3.14 CRC Error

This error exists only for isochronous IN pipes. It sets the PINTFLAG.TRFAIL, which triggers an interrupt if PINTENCLR/SET.TRFAIL is set. The user must check the PINTSMRY to find out the pipe which triggered the interrupt. Then the user must check the origin of the interrupt's bank by looking at the bank descriptor STATUS\_BK for each bank and if the CRC Error bit in STATUS\_BK (STATUS\_BK.CRCERR) is set then the user is able to determine the origin of the CRC error. A CRC error can occur during the IN stage if the USB detects a corrupted packet. The IN packet will remain stored in the bank and PINTFLAG.TRCPT0/1 will be set.

#### 40.6.3.15 PERR Error

This error exists for all pipes. It sets the PINTFLAG.PERR Interrupt, which triggers an interrupt if PINTFLAG.PERR is set. The user must check the PINTSMRY register to find out the pipe which can cause an interrupt.

A PERR error occurs if one of the error field in the STATUS\_PIPE register in the Host pipe descriptor is set and the Error Count field in STATUS\_PIPE (STATUS\_PIPE.ERCNT) exceeds the

maximum allowed number of Pipe error(s) as defined in Pipe Error Max Number field in CTRL\_PIPE (CTRL\_PIPE.PERMAX). Refer to [Host Control Pipe](#) and [Host Status Pipe](#) registers.

If one of the error field in the STATUS\_PIPE register from the Host Pipe Descriptor is set and the STATUS\_PIPE.ERCNT is less than the CTRL\_PIPE.PERMAX, the STATUS\_PIPE.ERCNT is incremented.

#### 40.6.3.16 Link Power Management L1 (LPM-L1) Suspend State Entry and Exit as Host.

An EXTENDED LPM transaction can be transmitted by any enabled pipe. The PCFGn.PTYPE should be set to EXTENDED. Other fields as PCFG.PTOKEN, PCFG.BK and PCKSIZE.SIZE are irrelevant in this configuration. The user should also set the EXTREG.VARIABLE in the descriptor as described in the EXTREG Register.

When the pipe is configured and enabled, an EXTENDED TOKEN followed by a LPM TOKEN are transmitted. The device responds with a valid HANDSHAKE, corrupted HANDSHAKE or no HANDSHAKE (TIME-OUT).

If the valid HANDSHAKE is an ACK, the host will immediately proceed to L1 SLEEP and the PINTFLAG.TRCT0 is set. The minimum duration of the L1 SLEEP state will be the TL1RetryAndResidency as defined in the reference document "ENGINEERING CHANGE NOTICE, USB 2.0 Link Power Management Addendum". When entering the L1 SLEEP state, the CTRLB.SOFE is cleared, avoiding Start-of-Frame generation.

If the valid HANDSHAKE is a NYET PINTFLAG.TRFAIL is set.

If the valid HANDSHAKE is a STALL the PINTFLAG.STALL is set.

If there is no HANDSHAKE or corrupted HANDSHAKE, the EXTENDED/LPM pair of TOKENS will be transmitted again until reaching the maximum number of retries as defined by the CTRL\_PIPE.PERMAX in the pipe descriptor.

If the last retry returns no valid HANDSHAKE, the PINTFLAGn.PERR is set, and the STATUS\_BK is updated in the pipe descriptor.

All LPM transactions, should they end up with a ACK, a NYET, a STALL or a PERR, will set the PSTATUS.PFREEZE bit, freezing the pipe before a succeeding operation. The user should unfreeze the pipe to start a new LPM transaction.

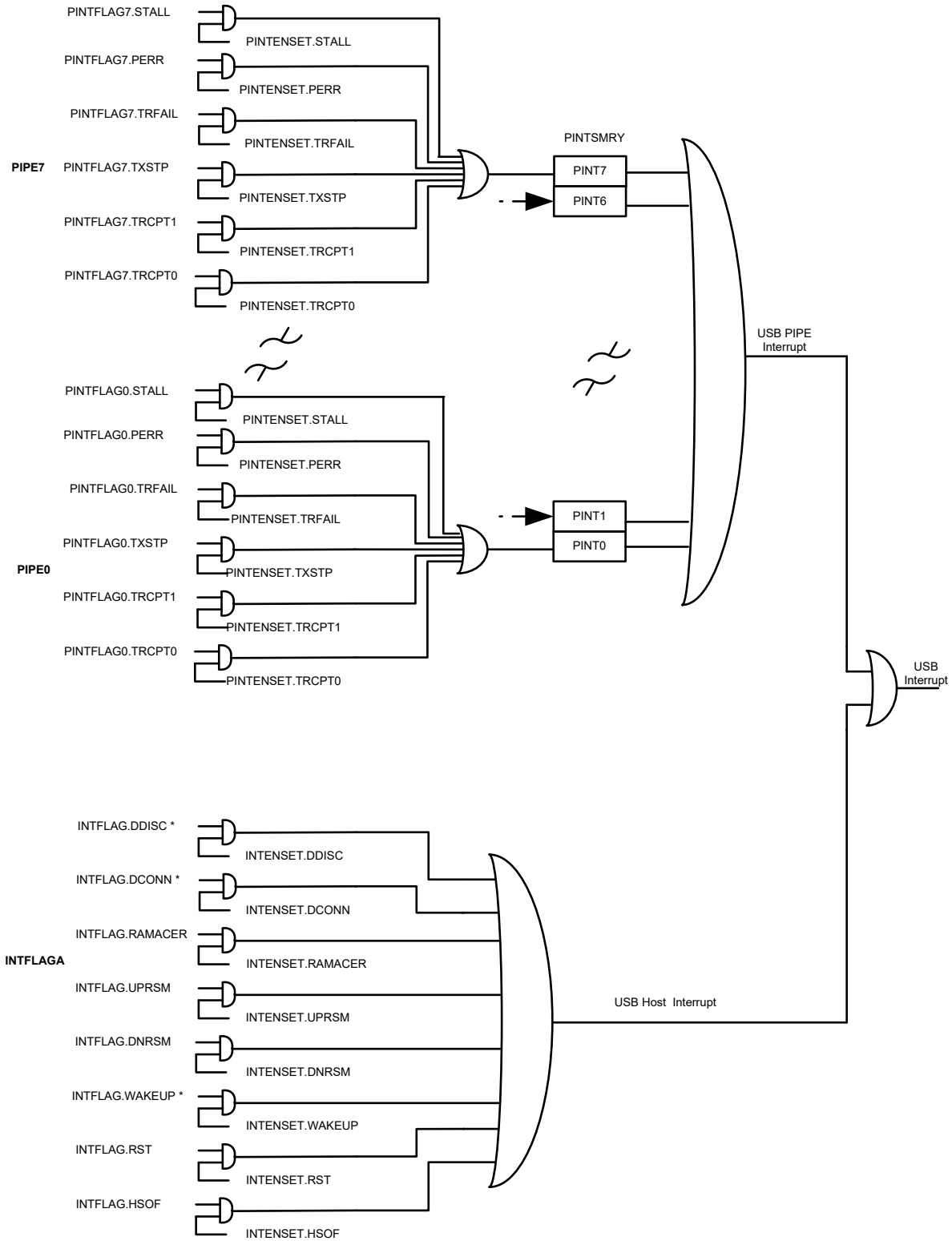
To exit the L1 STATE, the user initiate a DOWNSTREAM RESUME by setting the bit CTRLB.RESUME or a L1 RESUME by setting the Send L1 Resume bit in CTRLB (CTRLB.L1RESUME). In the case of a L1 RESUME, the K STATE duration is given by the BESL bit field in the EXTREG.VARIABLE field. Refer to the EXTREG Register.

When the host is in the L1 SLEEP state after a successful LPM transmitted, the device can initiate an UPSTREAM RESUME. This will set the Upstream Resume Interrupt bit in INTFLAG (INTFLAG.UPRSM). The host should proceed then to a L1 RESUME as described above.

After resuming from the L1 SLEEP state, the bit CTRLB.SOFE is set, allowing Start-of-Frame generation.

### 40.6.3.17 Host Interrupt

Figure 40-10. Host Interrupt



\* Asynchronous interrupt

The WAKEUP is an asynchronous interrupt and can be used to wake-up the device from any sleep

mode.

## 40.7 Common Device / Host Register Summary

Offset	Name	Bit Pos.	7	6	5	4	3	2	1	0
0x00	<b>CTRLA</b>	7:0	MODE					RUNSTDBY	ENABLE	SWRST
0x01	Reserved									
0x02	<b>SYNCBUSY</b>	7:0							ENABLE	SWRST
0x03	<b>QOSCTRL</b>	7:0					DQOS[1:0]		CQOS[1:0]	
0x04	Reserved									
...										
0x0C	Reserved									
0x0D	<b>FSMSTATUS</b>	7:0	FSMSTATE[6:0]							
0x0E	Reserved									
...										
0x23	Reserved									
0x24	<b>DESCADD</b>	7:0	DESCADD[7:0]							
		15:8	DESCADD[15:8]							
		23:16	DESCADD[23:16]							
		31:24	DESCADD[31:24]							
0x28	<b>PADCAL</b>	7:0	TRANSN[1:0]				TRANSP[4:0]			
		15:8		TRIM[2:0]				TRANSN[4:2]		



## 40.7.1 Control A

**Name:** CTRLA  
**Offset:** 0x00  
**Reset:** 0x00  
**Property:** PAC Write-Protection, Write-Synchronized Bits

Bit	7	6	5	4	3	2	1	0
	MODE					RUNSTDBY	ENABLE	SWRST
Access	R/W					R/W	R/W	R/W
Reset	0					0	0	0

### Bit 7 - MODE Operating Mode

This bit defines the operating mode of the USB.

Value	Description
0	USB Device mode
1	USB Host mode

### Bit 2 - RUNSTDBY Run in Standby Mode

This bit is Enable-Protected.

Value	Description
0	USB clock is stopped in standby mode.
1	USB clock is running in standby mode

### Bit 1 - ENABLE Enable

Due to synchronization there is delay from writing CTRLA.ENABLE until the peripheral is enabled/disabled. The value written to CTRLA.ENABLE will read back immediately and the Synchronization status enable bit in the Synchronization Busy register (SYNCBUSY.ENABLE) will be set. SYNCBUSY.ENABLE will be cleared when the operation is complete. This bit is Write-Synchronized.

Value	Description
0	The peripheral is disabled or being disabled.
1	The peripheral is enabled or being enabled.

### Bit 0 - SWRST Software Reset

Writing a zero to this bit has no effect.

Writing a '1' to this bit resets all registers in the USB, to their initial state, and the USB will be disabled.

Writing a '1' to CTRLA.SWRST will always take precedence, meaning that all other writes in the same write-operation will be discarded.

Due to synchronization there is a delay from writing CTRLA.SWRST until the reset is complete. CTRLA.SWRST and SYNCBUSY.SWRST will both be cleared when the reset is complete.

#### Notes:

1. When the CTRLA.SWRST is written, the user must poll the SYNCBUSY.SWRST bit to know when the reset operation is complete.
2. During a SWRST, access to registers/bits without the SWRST are disallowed until the SYNCBUSY.SWRST is cleared by hardware.

Value	Description
0	There is no reset operation ongoing.
1	The reset operation is ongoing.

## 40.7.2 Synchronization Busy

**Name:** SYNCBUSY  
**Offset:** 0x02  
**Reset:** 0x00  
**Property:** -

Bit	7	6	5	4	3	2	1	0
							ENABLE	SWRST
Access							R	R
Reset							0	0

### Bit 1 – ENABLE Synchronization Enable status bit

This bit is cleared when the synchronization of ENABLE register between the clock domains is complete.

This bit is set when the synchronization of ENABLE register between clock domains is started.

### Bit 0 – SWRST Synchronization Software Reset status bit

This bit is cleared when the synchronization of SWRST register between the clock domains is complete.

This bit is set when the synchronization of SWRST register between clock domains is started.

### 40.7.3 QOS Control

**Name:** QOSCTRL  
**Offset:** 0x03  
**Reset:** 0x000x0F  
**Property:** PAC Write-Protection

Bit	7	6	5	4	3	2	1	0
					DQOS[1:0]		CQOS[1:0]	
Access					R/W	R/W	R/W	R/W
Reset					0	0	0	0

**Bits 3:2 – DQOS[1:0]** Data Quality of Service

These bits define the memory priority access during the endpoint or pipe read/write data operation. Refer to *SRAM Quality of Service*.

**Bits 1:0 – CQOS[1:0]** Configuration Quality of Service

These bits define the memory priority access during the endpoint or pipe read/write configuration operation. Refer to *SRAM Quality of Service*.

#### 40.7.4 Finite State Machine Status

**Name:** FSMSTATUS  
**Offset:** 0x0D  
**Reset:** 0xFFFF  
**Property:** Read only

Bit	7	6	5	4	3	2	1	0
	FSMSTATE[6:0]							
Access		R	R	R	R	R	R	R
Reset		0	0	0	0	0	0	1

#### Bits 6:0 – FSMSTATE[6:0] Fine State Machine Status

These bits indicate the state of the finite state machine of the USB controller.

Value	Name	Description
0x01	OFF	Corresponds to the powered-off, disconnected, and disabled state.
0x02	ON	Corresponds to the Idle and Active states.
0x04	SUSPEND	-
0x08	SLEEP	-
0x10	DNRESUME	Down Stream Resume.
0x20	UPRESUME	Up Stream Resume.
0x40	RESET	USB lines Reset.
Others	-	Reserved

### 40.7.5 Descriptor Address

**Name:** DESCADD  
**Offset:** 0x24  
**Reset:** 0x00000000  
**Property:** PAC Write-Protection

Bit	31	30	29	28	27	26	25	24
	DESCADD[31:24]							
Access	R/W	R/W	R/W	R/W	R/W	R/W	R/W	R/W
Reset	0	0	0	0	0	0	0	0
Bit	23	22	21	20	19	18	17	16
	DESCADD[23:16]							
Access	R/W	R/W	R/W	R/W	R/W	R/W	R/W	R/W
Reset	0	0	0	0	0	0	0	0
Bit	15	14	13	12	11	10	9	8
	DESCADD[15:8]							
Access	R/W	R/W	R/W	R/W	R/W	R/W	R/W	R/W
Reset	0	0	0	0	0	0	0	0
Bit	7	6	5	4	3	2	1	0
	DESCADD[7:0]							
Access	R/W	R/W	R/W	R/W	R/W	R/W	R/W	R/W
Reset	0	0	0	0	0	0	0	0

#### Bits 31:0 – DESCADD[31:0] Descriptor Address Value

These bits define the base address of the main USB descriptor in RAM. The two least significant bits must be written to zero.

## 40.7.6 Pad Calibration

**Name:** PADCAL  
**Offset:** 0x28  
**Reset:** 0x0000  
**Property:** PAC Write-Protection

The Pad Calibration values must be loaded from the NVM Software Calibration Area into the USB Pad Calibration register by software, before enabling the USB, to achieve the specified accuracy. Refer to *NVM Software Calibration Area Mapping (SW0)* for additional information.

Bit	15	14	13	12	11	10	9	8
	TRIM[2:0]		TRIM[2:0]		TRANSN[4:2]		TRANSN[4:2]	
Access		R/W	R/W	R/W		R/W	R/W	R/W
Reset		0	0	0		0	0	0
Bit	7	6	5	4	3	2	1	0
	TRANSN[1:0]		TRANSN[1:0]		TRANSP[4:0]		TRANSP[4:0]	
Access	R/W	R/W		R/W	R/W	R/W	R/W	R/W
Reset	0	0		0	0	0	0	0

**Bits 14:12 – TRIM[2:0]** Trim bits for DP/DM  
 These bits calibrate the matching of rise/fall of DP/DM.

**Bits 10:6 – TRANSN[4:0]** Trimmable Output Driver Impedance N  
 These bits calibrate the NMOS output impedance of DP/DM drivers.

**Bits 4:0 – TRANSP[4:0]** Trimmable Output Driver Impedance P  
 These bits calibrate the PMOS output impedance of DP/DM drivers.

## 40.8 General Device Register Summary

Offset	Name	Bit Pos.	7	6	5	4	3	2	1	0	
0x00 ... 0x07	Reserved										
0x08	CTRLB	7:0				NREPLY		SPDCONF[1:0]	UPRSM	DETACH	
		15:8						LPMHDSK[1:0]	GNAK		
0x0A	DADD	7:0	ADDEN					DADD[6:0]			
0x0B	Reserved										
0x0C	STATUS	7:0	LINESTATE[1:0]					SPEED[1:0]			
0x0D ... 0x0F	Reserved										
0x10	FNUM	7:0	FNUM[4:0]								
		15:8	FNCERR			FNUM[10:5]					
0x12 ... 0x13	Reserved										
0x14	INTENCLR	7:0	RAMACER	UPRSM	EORSM	WAKEUP	EORST	SOF		SUSPEND	
		15:8							LPMSUSP	LPMNYET	
0x16 ... 0x17	Reserved										
0x18	INTENSET	7:0	RAMACER	UPRSM	EORSM	WAKEUP	EORST	SOF		SUSPEND	
		15:8							LPMSUSP	LPMNYET	
0x1A ... 0x1B	Reserved										
0x1C	INTFLAG	7:0	RAMACER	UPRSM	EORSM	WAKEUP	EORST	SOF		SUSPEND	
		15:8							LPMSUSP	LPMNYET	
0x1E ... 0x1F	Reserved										
0x20	EPINTSMRY	7:0	EPINT7	EPINT6	EPINT5	EPINT4	EPINT3	EPINT2	EPINT1	EPINT0	
		15:8									

## 40.8.1 Control B

**Name:** CTRLB  
**Offset:** 0x08  
**Reset:** 0x0001  
**Property:** PAC Write-Protection

Bit	15	14	13	12	11	10	9	8
					LPMHDSK[1:0]		GNAK	
Access					R/W	R/W	R/W	
Reset					0	0	0	
Bit	7	6	5	4	3	2	1	0
				NREPLY	SPDCONF[1:0]		UPRSM	DETACH
Access				R	R/W	R/W	R/W	R/W
Reset				0	0	0	0	1

**Bits 11:10 – LPMHDSK[1:0]** Link Power Management Handshake  
 These bits select the Link Power Management Handshake configuration.

Value	Name	Description
0x0	NO	No handshake. LPM is not supported.
0x1	ACK	ACK
0x2	NYET	NYET
0x3	-	Reserved

**Bit 9 – GNAK** Global NAK  
 This bit configures the operating mode of the NAK.  
 This bit is not synchronized.

Value	Description
0	The handshake packet reports the status of the USB transaction
1	A NAK handshake is answered for each USB transaction regardless of the current endpoint memory bank status

**Bit 4 – NREPLY** No reply excepted SETUP Token  
 This bit is cleared by hardware when receiving a SETUP packet.  
 This bit has no effect for any other endpoint but endpoint 0.

Value	Description
0	Disable the "NO_REPLY" feature: Any transaction to endpoint 0 will be handled according to the USB2.0 standard.
1	Enable the "NO_REPLY" feature: Any transaction to endpoint 0 will be ignored except SETUP.

**Bits 3:2 – SPDCONF[1:0]** Speed Configuration  
 These bits select the speed configuration.

Value	Name	Description
0x0	FS	Full-speed
0x1	LS	Low-speed
0x2	-	Reserved
0x3	-	Reserved

**Bit 1 – UPRSM** Upstream Resume  
 This bit is cleared when the USB receives a USB reset or once the upstream resume has been sent.

Value	Description
0	Writing a zero to this bit has no effect.
1	Writing a one to this bit will generate an upstream resume to the host for a remote wakeup.



**Bit 0 – DETACH** Detach

Value	Description
0	The device is attached to the USB bus so that communications may occur.
1	It is the default value at reset. The internal device pull-ups are disabled, removing the device from the USB bus.

## 40.8.2 Device Address

**Name:** DADD  
**Offset:** 0x0A  
**Reset:** 0x00  
**Property:** PAC Write-Protection

Bit	7	6	5	4	3	2	1	0
	ADDEN	DADD[6:0]						
Access	R/W	R/W	R/W	R/W	R/W	R/W	R/W	R/W
Reset	0	0	0	0	0	0	0	0

### Bit 7 - ADDEN Device Address Enable

This bit is cleared when a USB reset is received.

Value	Description
0	Writing a zero will deactivate the DADD field (USB device address) and return the device to default address 0.
1	Writing a one will activate the DADD field (USB device address).

### Bits 6:0 - DADD[6:0] Device Address

These bits define the device address. The DADD register is reset when a USB reset is received.

### 40.8.3 Status

**Name:** STATUS  
**Offset:** 0x0C  
**Reset:** 0x40  
**Property:** -

Bit	7	6	5	4	3	2	1	0
	LINESTATE[1:0]				SPEED[1:0]			
Access	R	R			R/W	R/W		
Reset	0	1			0	1		

#### Bits 7:6 – LINESTATE[1:0] USB Line State Status

These bits define the current line state DP/DM.

LINESTATE[1:0]	USB Line Status
0x0	SE0/RESET
0x1	FS-J or LS-K State
0x2	FS-K or LS-J State

#### Bits 3:2 – SPEED[1:0] Speed Status

These bits define the current speed used of the device.

SPEED[1:0]	SPEED STATUS
0x0	Full-speed mode
0x1	Low-speed mode
0x2	Reserved
0x3	Reserved

#### 40.8.4 Device Frame Number

**Name:** FNUM  
**Offset:** 0x10  
**Reset:** 0x0000  
**Property:** Read only

Bit	15	14	13	12	11	10	9	8
	FNCERR		FNUM[10:5]					
Access	R/W		R/W	R/W	R/W	R/W	R/W	R/W
Reset	0		0	0	0	0	0	0
Bit	7	6	5	4	3	2	1	0
	FNUM[4:0]							
Access	R/W	R/W	R/W	R/W	R/W			
Reset	0	0	0	0	0			

##### Bit 15 - FNCERR Frame Number CRC Error

This bit is cleared upon receiving a USB reset.

This bit is set when a corrupted frame number (or micro-frame number) is received.

This bit and the SOF (or MSOF) interrupt bit are updated at the same time.

##### Bits 13:3 - FNUM[10:0] Frame Number

These bits are cleared upon receiving a USB reset.

These bits are updated with the frame number information as provided from the last SOF packet even if a corrupted SOF is received.

## 40.8.5 Device Interrupt Enable Clear

**Name:** INTENCLR  
**Offset:** 0x14  
**Reset:** 0x0000  
**Property:** PAC Write-Protection

This register allows the user to disable an interrupt without doing a read-modify-write operation. Changes in this register will also be reflected in the Interrupt Enable Set (INTENSET) register.

Bit	15	14	13	12	11	10	9	8
							LPMUSUSP	LPMNYET
Access							R/W	R/W
Reset							0	0
Bit	7	6	5	4	3	2	1	0
	RAMACER	UPRSM	EORSM	WAKEUP	EORST	SOF		SUSPEND
Access	R/W	R/W	R/W	R/W	R/W	R/W		R/W
Reset	0	0	0	0	0	0		0

### Bit 9 – LPMUSUSP Link Power Management Suspend Interrupt Enable

Writing a zero to this bit has no effect.

Writing a one to this bit will clear the Link Power Management Suspend Interrupt Enable bit and disable the corresponding interrupt request.

Value	Description
0	The Link Power Management Suspend interrupt is disabled.
1	The Link Power Management Suspend interrupt is enabled and an interrupt request will be generated when the Link Power Management Suspend interrupt Flag is set.

### Bit 8 – LPMNYET Link Power Management Not Yet Interrupt Enable

Writing a zero to this bit has no effect.

Writing a one to this bit will clear the Link Power Management Not Yet interrupt Enable bit and disable the corresponding interrupt request.

Value	Description
0	The Link Power Management Not Yet interrupt is disabled.
1	The Link Power Management Not Yet interrupt is enabled and an interrupt request will be generated when the Link Power Management Not Yet interrupt Flag is set.

### Bit 7 – RAMACER RAM Access Interrupt Enable

Writing a zero to this bit has no effect.

Writing a one to this bit will clear the RAM Access interrupt Enable bit and disable the corresponding interrupt request.

Value	Description
0	The RAM Access interrupt is disabled.
1	The RAM Access interrupt is enabled and an interrupt request will be generated when the RAM Access interrupt Flag is set.

### Bit 6 – UPRSM Upstream Resume Interrupt Enable

Writing a zero to this bit has no effect.

Writing a one to this bit will clear the Upstream Resume interrupt Enable bit and disable the corresponding interrupt request.

Value	Description
0	The Upstream Resume interrupt is disabled.
1	The Upstream Resume interrupt is enabled and an interrupt request will be generated when the Upstream Resume interrupt Flag is set.

**Bit 5 – EORSM** End Of Resume Interrupt Enable

Writing a zero to this bit has no effect.

Writing a one to this bit will clear the End Of Resume interrupt Enable bit and disable the corresponding interrupt request.

Value	Description
0	The End Of Resume interrupt is disabled.
1	The End Of Resume interrupt is enabled and an interrupt request will be generated when the End Of Resume interrupt Flag is set.

**Bit 4 – WAKEUP** Wake-Up Interrupt Enable

Writing a zero to this bit has no effect.

Writing a one to this bit will clear the Wake Up interrupt Enable bit and disable the corresponding interrupt request.

Value	Description
0	The Wake Up interrupt is disabled.
1	The Wake Up interrupt is enabled and an interrupt request will be generated when the Wake Up interrupt Flag is set.

**Bit 3 – EORST** End of Reset Interrupt Enable

Writing a zero to this bit has no effect.

Writing a one to this bit will clear the End of Reset interrupt Enable bit and disable the corresponding interrupt request.

Value	Description
0	The End of Reset interrupt is disabled.
1	The End of Reset interrupt is enabled and an interrupt request will be generated when the End of Reset interrupt Flag is set.

**Bit 2 – SOF** Start-of-Frame Interrupt Enable

Writing a zero to this bit has no effect.

Writing a one to this bit will clear the Start-of-Frame interrupt Enable bit and disable the corresponding interrupt request.

Value	Description
0	The Start-of-Frame interrupt is disabled.
1	The Start-of-Frame interrupt is enabled and an interrupt request will be generated when the Start-of-Frame interrupt Flag is set.

**Bit 0 – SUSPEND** Suspend Interrupt Enable

Writing a zero to this bit has no effect.

Writing a one to this bit will clear the Suspend Interrupt Enable bit and disable the corresponding interrupt request.

Value	Description
0	The Suspend interrupt is disabled.
1	The Suspend interrupt is enabled and an interrupt request will be generated when the Suspend interrupt Flag is set.

## 40.8.6 Device Interrupt Enable Set

**Name:** INTENSET  
**Offset:** 0x18  
**Reset:** 0x0000  
**Property:** PAC Write-Protection

This register allows the user to enable an interrupt without doing a read-modify-write operation. Changes in this register will also be reflected in the Interrupt Enable Clear (INTENCLR) register.

Bit	15	14	13	12	11	10	9	8
							LPMSUSP	LPMNYET
Access							R/W	R/W
Reset							0	0
Bit	7	6	5	4	3	2	1	0
	RAMACER	UPRSM	EORSM	WAKEUP	EORST	SOF		SUSPEND
Access	R/W	R/W	R/W	R/W	R/W	R/W		R/W
Reset	0	0	0	0	0	0		0

### Bit 9 – LPMSUSP Link Power Management Suspend Interrupt Enable

Writing a zero to this bit has no effect.

Writing a one to this bit will set the Link Power Management Suspend Enable bit and enable the corresponding interrupt request.

Value	Description
0	The Link Power Management Suspend interrupt is disabled.
1	The Link Power Management Suspend interrupt is enabled.

### Bit 8 – LPMNYET Link Power Management Not Yet Interrupt Enable

Writing a zero to this bit has no effect.

Writing a one to this bit will set the Link Power Management Not Yet interrupt bit and enable the corresponding interrupt request.

Value	Description
0	The Link Power Management Not Yet interrupt is disabled.
1	The Link Power Management Not Yet interrupt is enabled.

### Bit 7 – RAMACER RAM Access Interrupt Enable

Writing a zero to this bit has no effect.

Writing a one to this bit will set the RAM Access Enable bit and enable the corresponding interrupt request.

Value	Description
0	The RAM Access interrupt is disabled.
1	The RAM Access interrupt is enabled.

### Bit 6 – UPRSM Upstream Resume Interrupt Enable

Writing a zero to this bit has no effect.

Writing a one to this bit will set the Upstream Resume Enable bit and enable the corresponding interrupt request.

Value	Description
0	The Upstream Resume interrupt is disabled.
1	The Upstream Resume interrupt is enabled.

### Bit 5 – EORSM End Of Resume Interrupt Enable

Writing a zero to this bit has no effect.

Writing a one to this bit will set the End Of Resume interrupt Enable bit and enable the corresponding interrupt request.

Value	Description
0	The End Of Resume interrupt is disabled.
1	The End Of Resume interrupt is enabled.

**Bit 4 - WAKEUP** Wake-Up Interrupt Enable

Writing a zero to this bit has no effect.

Writing a one to this bit will set the Wake Up interrupt Enable bit and enable the corresponding interrupt request.

Value	Description
0	The Wake Up interrupt is disabled.
1	The Wake Up interrupt is enabled.

**Bit 3 - EORST** End of Reset Interrupt Enable

Writing a zero to this bit has no effect.

Writing a one to this bit will set the End of Reset interrupt Enable bit and enable the corresponding interrupt request.

Value	Description
0	The End of Reset interrupt is disabled.
1	The End of Reset interrupt is enabled.

**Bit 2 - SOF** Start-of-Frame Interrupt Enable

Writing a zero to this bit has no effect.

Writing a one to this bit will set the Start-of-Frame interrupt Enable bit and enable the corresponding interrupt request.

Value	Description
0	The Start-of-Frame interrupt is disabled.
1	The Start-of-Frame interrupt is enabled.

**Bit 0 - SUSPEND** Suspend Interrupt Enable

Writing a zero to this bit has no effect.

Writing a one to this bit will set the Suspend interrupt Enable bit and enable the corresponding interrupt request.

Value	Description
0	The Suspend interrupt is disabled.
1	The Suspend interrupt is enabled.



## 40.8.7 Device Interrupt Flag Status and Clear

**Name:** INTFLAG  
**Offset:** 0x01C  
**Reset:** 0x0000  
**Property:** -

Bit	15	14	13	12	11	10	9	8
Access							LPMSUSP	LPMNYET
Reset							R/W	R/W
							0	0
Bit	7	6	5	4	3	2	1	0
Access	RAMACER	UPRSM	EORSM	WAKEUP	EORST	SOF		SUSPEND
Reset	R/W	R/W	R/W	R/W	R/W	R/W		R/W
	0	0	0	0	0	0		0

### Bit 9 – LPMSUSP Link Power Management Suspend Interrupt Flag

This flag is cleared by writing a one to the flag.

This flag is set when the USB module acknowledge a Link Power Management Transaction (ACK handshake) and has entered the Suspended state and will generate an interrupt if INTENCLR/SET.LPMSUSP is one.

Writing a zero to this bit has no effect.

Writing a one to this bit clears the LPMSUSP Interrupt Flag.

### Bit 8 – LPMNYET Link Power Management Not Yet Interrupt Flag

This flag is cleared by writing a one to the flag.

This flag is set when the USB module acknowledges a Link Power Management Transaction (handshake is NYET) and will generate an interrupt if INTENCLR/SET.LPMNYET is one.

Writing a zero to this bit has no effect.

Writing a one to this bit clears the LPMNYET Interrupt Flag.

### Bit 7 – RAMACER RAM Access Interrupt Flag

This flag is cleared by writing a one to the flag.

This flag is set when a RAM access underflow error occurs during IN data stage. This bit will generate an interrupt if INTENCLR/SET.RAMACER is one.

Writing a zero to this bit has no effect.

### Bit 6 – UPRSM Upstream Resume Interrupt Flag

This flag is cleared by writing a one to the flag.

This flag is set when the USB sends a resume signal called “Upstream Resume” and will generate an interrupt if INTENCLR/SET.UPRSM is one.

Writing a zero to this bit has no effect.

### Bit 5 – EORSM End Of Resume Interrupt Flag

This flag is cleared by writing a one to the flag.

This flag is set when the USB detects a valid “End of Resume” signal initiated by the host and will generate an interrupt if INTENCLR/SET.EORSM is one.

Writing a zero to this bit has no effect.

### Bit 4 – WAKEUP Wake Up Interrupt Flag

This flag is cleared by writing a one to the flag.

This flag is set when the USB is reactivated by a filtered non-idle signal from the lines and will generate an interrupt if INTENCLR/SET.WAKEUP is one.

Writing a zero to this bit has no effect.

**Bit 3 – EORST** End of Reset Interrupt Flag

This flag is cleared by writing a one to the flag.

This flag is set when a USB “End of Reset” has been detected and will generate an interrupt if INTENCLR/SET.EORST is one.

Writing a zero to this bit has no effect.

**Bit 2 – SOF** Start-of-Frame Interrupt Flag

This flag is cleared by writing a one to the flag.

This flag is set when a USB “Start-of-Frame” has been detected (every 1 ms) and will generate an interrupt if INTENCLR/SET.SOF is one.

The FNUM is updated.

Writing a zero to this bit has no effect.

**Bit 0 – SUSPEND** Suspend Interrupt Flag

This flag is cleared by writing a one to the flag.

This flag is set when a USB “Suspend” idle state has been detected for 3 frame periods (J state for 3 ms) and will generate an interrupt if INTENCLR/SET.SUSPEND is one.

Writing a zero to this bit has no effect.

## 40.8.8 Endpoint Interrupt Summary

**Name:** EPINTSMRY  
**Offset:** 0x20  
**Reset:** 0x0000  
**Property:** -

Bit	15	14	13	12	11	10	9	8
Access								
Reset								
Bit	7	6	5	4	3	2	1	0
Access	R	R	R	R	R	R	R	R
Reset	0	0	0	0	0	0	0	0

### Bits 0, 1, 2, 3, 4, 5, 6, 7 – EPINT EndPoint Interrupt

The flag EPINT[n] is set when an interrupt is triggered by the EndPoint n. Refer to the EPINTFLAGn register in the Device EndPoint section.

This bit will be cleared when no interrupts are pending for EndPoint n.

## 40.9 Device Endpoint n Register Summary

Offset	Name	Bit Pos.	7	6	5	4	3	2	1	0
0x00 ... 0xFF	Reserved									
0x0100	<a href="#">EPCFG0</a>	7:0	EPTYPE1[2:0]			EPTYPE0[2:0]				
0x0101 ... 0x0103	Reserved									
0x0104	<a href="#">EPSTATUSCLR0</a>	7:0	BK1RDY	BK0RDY	STALLRQ1	STALLRQ0		CURBK	DTGLIN	DTGLOUT
0x0105	<a href="#">EPSTATUSSET0</a>	7:0	BK1RDY	BK0RDY	STALLRQ1	STALLRQ0		CURBK	DTGLIN	DTGLOUT
0x0106	<a href="#">EPSTATUS0</a>	7:0	BK1RDY	BK0RDY	STALLRQ1	STALLRQ0		CURBK	DTGLIN	DTGLOUT
0x0107	<a href="#">EPINTFLAG0</a>	7:0		STALL1	STALLO	RXSTP	TRFAIL1	TRFAIL0	TRCPT1	TRCPT0
0x0108	<a href="#">EPINTENCLR0</a>	7:0		STALL1	STALLO	RXSTP	TRFAIL1	TRFAIL0	TRCPT1	TRCPT0
0x0109	<a href="#">EPINTENSET0</a>	7:0		STALL1	STALLO	RXSTP	TRFAIL1	TRFAIL0	TRCPT1	TRCPT0
0x010A ... 0x011F	Reserved									
0x0120	<a href="#">EPCFG1</a>	7:0	EPTYPE1[2:0]			EPTYPE0[2:0]				
0x0121 ... 0x0123	Reserved									
0x0124	<a href="#">EPSTATUSCLR1</a>	7:0	BK1RDY	BK0RDY	STALLRQ1	STALLRQ0		CURBK	DTGLIN	DTGLOUT
0x0125	<a href="#">EPSTATUSSET1</a>	7:0	BK1RDY	BK0RDY	STALLRQ1	STALLRQ0		CURBK	DTGLIN	DTGLOUT
0x0126	<a href="#">EPSTATUS1</a>	7:0	BK1RDY	BK0RDY	STALLRQ1	STALLRQ0		CURBK	DTGLIN	DTGLOUT
0x0127	<a href="#">EPINTFLAG1</a>	7:0		STALL1	STALLO	RXSTP	TRFAIL1	TRFAIL0	TRCPT1	TRCPT0
0x0128	<a href="#">EPINTENCLR1</a>	7:0		STALL1	STALLO	RXSTP	TRFAIL1	TRFAIL0	TRCPT1	TRCPT0
0x0129	<a href="#">EPINTENSET1</a>	7:0		STALL1	STALLO	RXSTP	TRFAIL1	TRFAIL0	TRCPT1	TRCPT0
0x012A ... 0x013F	Reserved									
0x0140	<a href="#">EPCFG2</a>	7:0	EPTYPE1[2:0]			EPTYPE0[2:0]				
0x0141 ... 0x0143	Reserved									
0x0144	<a href="#">EPSTATUSCLR2</a>	7:0	BK1RDY	BK0RDY	STALLRQ1	STALLRQ0		CURBK	DTGLIN	DTGLOUT
0x0145	<a href="#">EPSTATUSSET2</a>	7:0	BK1RDY	BK0RDY	STALLRQ1	STALLRQ0		CURBK	DTGLIN	DTGLOUT
0x0146	<a href="#">EPSTATUS2</a>	7:0	BK1RDY	BK0RDY	STALLRQ1	STALLRQ0		CURBK	DTGLIN	DTGLOUT
0x0147	<a href="#">EPINTFLAG2</a>	7:0		STALL1	STALLO	RXSTP	TRFAIL1	TRFAIL0	TRCPT1	TRCPT0
0x0148	<a href="#">EPINTENCLR2</a>	7:0		STALL1	STALLO	RXSTP	TRFAIL1	TRFAIL0	TRCPT1	TRCPT0
0x0149	<a href="#">EPINTENSET2</a>	7:0		STALL1	STALLO	RXSTP	TRFAIL1	TRFAIL0	TRCPT1	TRCPT0
0x014A ... 0x015F	Reserved									
0x0160	<a href="#">EPCFG3</a>	7:0	EPTYPE1[2:0]			EPTYPE0[2:0]				
0x0161 ... 0x0163	Reserved									
0x0164	<a href="#">EPSTATUSCLR3</a>	7:0	BK1RDY	BK0RDY	STALLRQ1	STALLRQ0		CURBK	DTGLIN	DTGLOUT
0x0165	<a href="#">EPSTATUSSET3</a>	7:0	BK1RDY	BK0RDY	STALLRQ1	STALLRQ0		CURBK	DTGLIN	DTGLOUT
0x0166	<a href="#">EPSTATUS3</a>	7:0	BK1RDY	BK0RDY	STALLRQ1	STALLRQ0		CURBK	DTGLIN	DTGLOUT
0x0167	<a href="#">EPINTFLAG3</a>	7:0		STALL1	STALLO	RXSTP	TRFAIL1	TRFAIL0	TRCPT1	TRCPT0
0x0168	<a href="#">EPINTENCLR3</a>	7:0		STALL1	STALLO	RXSTP	TRFAIL1	TRFAIL0	TRCPT1	TRCPT0
0x0169	<a href="#">EPINTENSET3</a>	7:0		STALL1	STALLO	RXSTP	TRFAIL1	TRFAIL0	TRCPT1	TRCPT0
0x016A ... 0x017F	Reserved									
0x0180	<a href="#">EPCFG4</a>	7:0	EPTYPE1[2:0]			EPTYPE0[2:0]				
0x0181 ... 0x0183	Reserved									
0x0184	<a href="#">EPSTATUSCLR4</a>	7:0	BK1RDY	BK0RDY	STALLRQ1	STALLRQ0		CURBK	DTGLIN	DTGLOUT

.....continued

Offset	Name	Bit Pos.	7	6	5	4	3	2	1	0
0x0185	EPSTATUSSET4	7:0	BK1RDY	BK0RDY	STALLRQ1	STALLRQ0		CURBK	DTGLIN	DTGLOUT
0x0186	EPSTATUS4	7:0	BK1RDY	BK0RDY	STALLRQ1	STALLRQ0		CURBK	DTGLIN	DTGLOUT
0x0187	EPINTFLAG4	7:0		STALL1	STALLO	RXSTP	TRFAIL1	TRFAIL0	TRCPT1	TRCPT0
0x0188	EPINTENCLR4	7:0		STALL1	STALLO	RXSTP	TRFAIL1	TRFAIL0	TRCPT1	TRCPT0
0x0189	EPINTENSET4	7:0		STALL1	STALLO	RXSTP	TRFAIL1	TRFAIL0	TRCPT1	TRCPT0
0x018A	...									
...	Reserved									
0x019F										
0x01A0	EPCFG5	7:0		EPTYPE1[2:0]				EPTYPE0[2:0]		
0x01A1	...									
...	Reserved									
0x01A3										
0x01A4	EPSTATUSCLR5	7:0	BK1RDY	BK0RDY	STALLRQ1	STALLRQ0		CURBK	DTGLIN	DTGLOUT
0x01A5	EPSTATUSSET5	7:0	BK1RDY	BK0RDY	STALLRQ1	STALLRQ0		CURBK	DTGLIN	DTGLOUT
0x01A6	EPSTATUS5	7:0	BK1RDY	BK0RDY	STALLRQ1	STALLRQ0		CURBK	DTGLIN	DTGLOUT
0x01A7	EPINTFLAG5	7:0		STALL1	STALLO	RXSTP	TRFAIL1	TRFAIL0	TRCPT1	TRCPT0
0x01A8	EPINTENCLR5	7:0		STALL1	STALLO	RXSTP	TRFAIL1	TRFAIL0	TRCPT1	TRCPT0
0x01A9	EPINTENSET5	7:0		STALL1	STALLO	RXSTP	TRFAIL1	TRFAIL0	TRCPT1	TRCPT0
0x01AA	...									
...	Reserved									
0x01BF										
0x01C0	EPCFG6	7:0		EPTYPE1[2:0]				EPTYPE0[2:0]		
0x01C1	...									
...	Reserved									
0x01C3										
0x01C4	EPSTATUSCLR6	7:0	BK1RDY	BK0RDY	STALLRQ1	STALLRQ0		CURBK	DTGLIN	DTGLOUT
0x01C5	EPSTATUSSET6	7:0	BK1RDY	BK0RDY	STALLRQ1	STALLRQ0		CURBK	DTGLIN	DTGLOUT
0x01C6	EPSTATUS6	7:0	BK1RDY	BK0RDY	STALLRQ1	STALLRQ0		CURBK	DTGLIN	DTGLOUT
0x01C7	EPINTFLAG6	7:0		STALL1	STALLO	RXSTP	TRFAIL1	TRFAIL0	TRCPT1	TRCPT0
0x01C8	EPINTENCLR6	7:0		STALL1	STALLO	RXSTP	TRFAIL1	TRFAIL0	TRCPT1	TRCPT0
0x01C9	EPINTENSET6	7:0		STALL1	STALLO	RXSTP	TRFAIL1	TRFAIL0	TRCPT1	TRCPT0
0x01CA	...									
...	Reserved									
0x01DF										
0x01E0	EPCFG7	7:0		EPTYPE1[2:0]				EPTYPE0[2:0]		
0x01E1	...									
...	Reserved									
0x01E3										
0x01E4	EPSTATUSCLR7	7:0	BK1RDY	BK0RDY	STALLRQ1	STALLRQ0		CURBK	DTGLIN	DTGLOUT
0x01E5	EPSTATUSSET7	7:0	BK1RDY	BK0RDY	STALLRQ1	STALLRQ0		CURBK	DTGLIN	DTGLOUT
0x01E6	EPSTATUS7	7:0	BK1RDY	BK0RDY	STALLRQ1	STALLRQ0		CURBK	DTGLIN	DTGLOUT
0x01E7	EPINTFLAG7	7:0		STALL1	STALLO	RXSTP	TRFAIL1	TRFAIL0	TRCPT1	TRCPT0
0x01E8	EPINTENCLR7	7:0		STALL1	STALLO	RXSTP	TRFAIL1	TRFAIL0	TRCPT1	TRCPT0
0x01E9	EPINTENSET7	7:0		STALL1	STALLO	RXSTP	TRFAIL1	TRFAIL0	TRCPT1	TRCPT0

### 40.9.1 Device Endpoint Configuration register n

**Name:** EPCFGn  
**Offset:** 0x0100 + n\*0x20 [n=0..7]  
**Reset:** 0x00  
**Property:** PAC Write-Protection

Bit	7	6	5	4	3	2	1	0
		EPTYPE1[2:0]				EPTYPE0[2:0]		
Access		R/W	R/W	R/W		R/W	R/W	R/W
Reset		0	0	0		0	0	0

#### Bits 6:4 – EPTYPE1[2:0] Endpoint Type for IN direction

These bits contains the endpoint type for IN direction.

Upon receiving a USB reset EPCFGn.EPTYPE1 is cleared except for endpoint 0 which is unchanged.

Value	Description
0x0	Bank1 is disabled.
0x1	Bank1 is enabled and configured as Control IN.
0x2	Bank1 is enabled and configured as Isochronous IN.
0x3	Bank1 is enabled and configured as Bulk IN.
0x4	Bank1 is enabled and configured as Interrupt IN.
0x5	Bank1 is enabled and configured as Dual-Bank OUT (Endpoint type is the same as the one defined in EPTYPE0)
0x6-0x7	Reserved

#### Bits 2:0 – EPTYPE0[2:0] Endpoint Type for OUT direction

These bits contains the endpoint type for OUT direction.

Upon receiving a USB reset EPCFGn.EPTYPE0 is cleared except for endpoint 0 which is unchanged.

Value	Description
0x0	Bank0 is disabled.
0x1	Bank0 is enabled and configured as Control SETUP / Control OUT.
0x2	Bank0 is enabled and configured as Isochronous OUT.
0x3	Bank0 is enabled and configured as Bulk OUT.
0x4	Bank0 is enabled and configured as Interrupt OUT.
0x5	Bank0 is enabled and configured as Dual Bank IN (Endpoint type is the same as the one defined in EPTYPE1)
0x6-0x7	Reserved

## 40.9.2 EndPoint Status Clear n

**Name:** EPSTATUSCLRn  
**Offset:** 0x0104 + n\*0x20 [n=0..7]  
**Reset:** 0x00  
**Property:** PAC Write-Protection

Bit	7	6	5	4	3	2	1	0
	BK1RDY	BK0RDY	STALLRQ1	STALLRQ0		CURBK	DTGLIN	DTGLOUT
Access	W	W	W	W		W	W	W
Reset	0	0	0	0		0	0	0

### Bit 7 – BK1RDY Bank 1 Ready Clear

Writing a zero to this bit has no effect.  
 Writing a one to this bit will clear EPSTATUS.BK1RDY bit.

### Bit 6 – BK0RDY Bank 0 Ready Clear

Writing a zero to this bit has no effect.  
 Writing a one to this bit will clear EPSTATUS.BK0RDY bit.

### Bit 5 – STALLRQ1 STALL bank 1 Request Clear

Writing a zero to this bit has no effect.  
 Writing a one to this bit will clear EPSTATUS.STALLRQ1 bit.

### Bit 4 – STALLRQ0 STALL bank 0 Request Clear

Writing a zero to this bit has no effect.  
 Writing a one to this bit will clear EPSTATUS.STALLRQ0 bit.

### Bit 2 – CURBK Current Bank Clear

Writing a zero to this bit has no effect.  
 Writing a one to this bit will clear EPSTATUS.CURBK bit.

### Bit 1 – DTGLIN Data Toggle IN Clear

Writing a zero to this bit has no effect.  
 Writing a one to this bit will clear EPSTATUS.DTGLIN bit.

### Bit 0 – DTGLOUT Data Toggle OUT Clear

Writing a zero to this bit has no effect.  
 Writing a one to this bit will clear the EPSTATUS.DTGLOUT bit.

### 40.9.3 EndPoint Status Set n

**Name:** EPSTATUSSETn  
**Offset:** 0x0105 + n\*0x20 [n=0..7]  
**Reset:** 0x00  
**Property:** PAC Write-Protection

Bit	7	6	5	4	3	2	1	0
	BK1RDY	BKORDY	STALLRQ1	STALLRQ0		CURBK	DTGLIN	DTGLOUT
Access	W	W	W	W		W	W	W
Reset	0	0	0	0		0	0	0

**Bit 7 – BK1RDY** Bank 1 Ready Set  
 Writing a zero to this bit has no effect.  
 Writing a one to this bit will set EPSTATUS.BK1RDY bit.

**Bit 6 – BKORDY** Bank 0 Ready Set  
 Writing a zero to this bit has no effect.  
 Writing a one to this bit will set EPSTATUS.BKORDY bit.

**Bit 5 – STALLRQ1** STALL Request bank 1 Set  
 Writing a zero to this bit has no effect.  
 Writing a one to this bit will set EPSTATUS.STALLRQ1 bit.

**Bit 4 – STALLRQ0** STALL Request bank 0 Set  
 Writing a zero to this bit has no effect.  
 Writing a one to this bit will set EPSTATUS.STALLRQ0 bit.

**Bit 2 – CURBK** Current Bank Set  
 Writing a zero to this bit has no effect.  
 Writing a one to this bit will set EPSTATUS.CURBK bit.

**Bit 1 – DTGLIN** Data Toggle IN Set  
 Writing a zero to this bit has no effect.  
 Writing a one to this bit will set EPSTATUS.DTGLIN bit.

**Bit 0 – DTGLOUT** Data Toggle OUT Set  
 Writing a zero to this bit has no effect.  
 Writing a one to this bit will set the EPSTATUS.DTGLOUT bit.



## 40.9.4 EndPoint Status n

**Name:** EPSTATUSn  
**Offset:** 0x0106 + n\*0x20 [n=0..7]  
**Reset:** 0x00  
**Property:** PAC Write-Protection

Bit	7	6	5	4	3	2	1	0
	BK1RDY	BK0RDY	STALLRQ1	STALLRQ0		CURBK	DTGLIN	DTGLOUT
Access	R	R	R	R		R	R	R
Reset	0	0	0	2		0	0	0

### Bit 7 – BK1RDY Bank 1 is ready

For Control/OUT direction Endpoints, the bank is empty.  
 Writing a one to the bit EPSTATUSCLR.BK1RDY will clear this bit.  
 Writing a one to the bit EPSTATUSSET.BK1RDY will set this bit.

Value	Description
0	The bank number 1 is not ready : For IN direction Endpoints, the bank is not yet filled in.
1	The bank number 1 is ready: For IN direction Endpoints, the bank is filled in. For Control/OUT direction Endpoints, the bank is full.

### Bit 6 – BK0RDY Bank 0 is ready

Writing a one to the bit EPSTATUSCLR.BK0RDY will clear this bit.  
 Writing a one to the bit EPSTATUSSET.BK0RDY will set this bit.

Value	Description
0	The bank number 0 is not ready : For IN direction Endpoints, the bank is not yet filled in. For Control/OUT direction Endpoints, the bank is empty.
1	The bank number 0 is ready: For IN direction Endpoints, the bank is filled in. For Control/OUT direction Endpoints, the bank is full.

### Bits 4, 5 – STALLRQ STALL bank x request

Writing a zero to the bit EPSTATUSCLR.STALLRQ will clear this bit.  
 Writing a one to the bit EPSTATUSSET.STALLRQ will set this bit.  
 This bit is cleared by hardware when receiving a SETUP packet.

Value	Description
0	Disable STALLRQx feature.
1	Enable STALLRQx feature: a STALL handshake will be sent to the host in regards to bank x.

### Bit 2 – CURBK Current Bank

Writing a zero to the bit EPSTATUSCLR.CURBK will clear this bit.  
 Writing a one to the bit EPSTATUSSET.CURBK will set this bit.

Value	Description
0	The bank0 is the bank that will be used in the next single/multi USB packet.
1	The bank1 is the bank that will be used in the next single/multi USB packet.

### Bit 1 – DTGLIN Data Toggle IN Sequence

Writing a zero to the bit EPSTATUSCLR.DTGLINCLR will clear this bit.  
 Writing a one to the bit EPSTATUSSET.DTGLINSET will set this bit.

Value	Description
0	The PID of the next expected IN transaction will be zero: data 0.
1	The PID of the next expected IN transaction will be one: data 1.

### Bit 0 – DTGLOUT Data Toggle OUT Sequence

Writing a zero to the bit EPSTATUSCLR.DTGLOUTCLR will clear this bit.  
 Writing a one to the bit EPSTATUSSET.DTGLOUTSET will set this bit.

Value	Description
0	The PID of the next expected OUT transaction will be zero: data 0.
1	The PID of the next expected OUR transaction will be one: data 1.

### 40.9.5 Device EndPoint Interrupt Flag n

**Name:** EPINTFLAGn  
**Offset:** 0x0107 + n\*0x20 [n=0..7]  
**Reset:** 0x00  
**Property:** -

Bit	7	6	5	4	3	2	1	0
		STALL1	STALLO	RXSTP	TRFAIL1	TRFAILO	TRCPT1	TRCPT0
Access		R/W	R/W	R/W	R/W	R/W	R/W	R/W
Reset		0	2	0	0	2	0	2

#### Bits 5, 6 – STALL Transmit Stall x Interrupt Flag

This flag is cleared by writing a one to the flag.

This flag is set when a Transmit Stall occurs and will generate an interrupt if EPINTENCLR/SET.STALL is one.

EPINTFLAG.STALL is set for a single bank OUT endpoint or double bank IN/OUT endpoint when current bank is "0".

Writing a zero to this bit has no effect.

Writing a one to this bit clears the STALL Interrupt Flag.

#### Bit 4 – RXSTP Received Setup Interrupt Flag

This flag is cleared by writing a one to the flag.

This flag is set when a Received Setup occurs and will generate an interrupt if EPINTENCLR/SET.RXSTP is one.

Writing a zero to this bit has no effect.

Writing a one to this bit clears the RXSTP Interrupt Flag.

#### Bits 2, 3 – TRFAIL Transfer Fail x Interrupt Flag

This flag is cleared by writing a one to the flag.

This flag is set when a transfer fail occurs and will generate an interrupt if EPINTENCLR/SET.TRFAIL is one.

EPINTFLAG.TRFAIL is set for a single bank OUT endpoint or double bank IN/OUT endpoint when current bank is "0".

Writing a zero to this bit has no effect.

Writing a one to this bit clears the TRFAIL Interrupt Flag.

#### Bits 0, 1 – TRCPT Transfer Complete x interrupt Flag

This flag is cleared by writing a one to the flag.

This flag is set when a Transfer complete occurs and will generate an interrupt if EPINTENCLR/SET.TRCPT is one. EPINTFLAG.TRCPT is set for a single bank OUT endpoint or double bank IN/OUT endpoint when current bank is "0".

Writing a zero to this bit has no effect.

Writing a one to this bit clears the TRCPT0 Interrupt Flag.

## 40.9.6 Device EndPoint Interrupt Enable n

**Name:** EPINTENCLRn  
**Offset:** 0x0108 + n\*0x20 [n=0..7]  
**Reset:** 0x00  
**Property:** PAC Write-Protection

This register allows the user to enable an interrupt without doing a read-modify-write operation. Changes in this register will also be reflected in the Endpoint Interrupt Enable Set (EPINTENSET) register.

Bit	7	6	5	4	3	2	1	0
		STALL1	STALLO	RXSTP	TRFAIL1	TRFAILO	TRCPT1	TRCPT0
Access		R/W	R/W	R/W	R/W	R/W	R/W	R/W
Reset		0	2	0	0	2	0	2

### Bits 5, 6 – STALL Transmit STALL x Interrupt Enable

Writing a zero to this bit has no effect.

Writing a one to this bit will clear the Transmit Stall x Interrupt Enable bit and disable the corresponding interrupt request.

Value	Description
0	The Transmit Stall x interrupt is disabled.
1	The Transmit Stall x interrupt is enabled and an interrupt request will be generated when the Transmit Stall x Interrupt Flag is set.

### Bit 4 – RXSTP Received Setup Interrupt Enable

Writing a zero to this bit has no effect.

Writing a one to this bit will clear the Received Setup Interrupt Enable bit and disable the corresponding interrupt request.

Value	Description
0	The Received Setup interrupt is disabled.
1	The Received Setup interrupt is enabled and an interrupt request will be generated when the Received Setup Interrupt Flag is set.

### Bits 2, 3 – TRFAIL Transfer Fail x Interrupt Enable

The user should look into the descriptor table status located in ram to be informed about the error condition : ERRORFLOW, CRC.

Writing a zero to this bit has no effect.

Writing a one to this bit will clear the Transfer Fail x Interrupt Enable bit and disable the corresponding interrupt request.

Value	Description
0	The Transfer Fail bank x interrupt is disabled.
1	The Transfer Fail bank x interrupt is enabled and an interrupt request will be generated when the Transfer Fail x Interrupt Flag is set.

### Bits 0, 1 – TRCPT Transfer Complete x interrupt Enable

Writing a zero to this bit has no effect.

Writing a one to this bit will clear the Transfer Complete x interrupt Enable bit and disable the corresponding interrupt request.

Value	Description
0	The Transfer Complete bank x interrupt is disabled.
1	The Transfer Complete bank x interrupt is enabled and an interrupt request will be generated when the Transfer Complete x Interrupt Flag is set.

## 40.9.7 Device Interrupt EndPoint Set n

**Name:** EPINTENSETn  
**Offset:** 0x0109 + n\*0x20 [n=0..7]  
**Reset:** 0x0000  
**Property:** PAC Write-Protection

This register allows the user to enable an interrupt without doing a read-modify-write operation. Changes in this register will also be reflected in the Endpoint Interrupt Enable Clear (EPINTENCLR) register. This register is cleared by USB reset.

Bit	7	6	5	4	3	2	1	0
		STALL1	STALL0	RXSTP	TRFAIL1	TRFAIL0	TRCPT1	TRCPT0
Access		R/W	R/W	R/W	R/W	R/W	R/W	R/W
Reset		0	2	0	0	2	0	2

### Bits 5, 6 – STALL Transmit Stall x Interrupt Enable

Writing a zero to this bit has no effect.

Writing a one to this bit will enable the Transmit bank x Stall interrupt.

Value	Description
0	The Transmit Stall x interrupt is disabled.
1	The Transmit Stall x interrupt is enabled.

### Bit 4 – RXSTP Received Setup Interrupt Enable

Writing a zero to this bit has no effect.

Writing a one to this bit will enable the Received Setup interrupt.

Value	Description
0	The Received Setup interrupt is disabled.
1	The Received Setup interrupt is enabled.

### Bits 2, 3 – TRFAIL Transfer Fail bank x Interrupt Enable

Writing a zero to this bit has no effect.

Writing a one to this bit will enable the Transfer Fail interrupt.

Value	Description
0	The Transfer Fail interrupt is disabled.
1	The Transfer Fail interrupt is enabled.

### Bits 0, 1 – TRCPT Transfer Complete bank x interrupt Enable

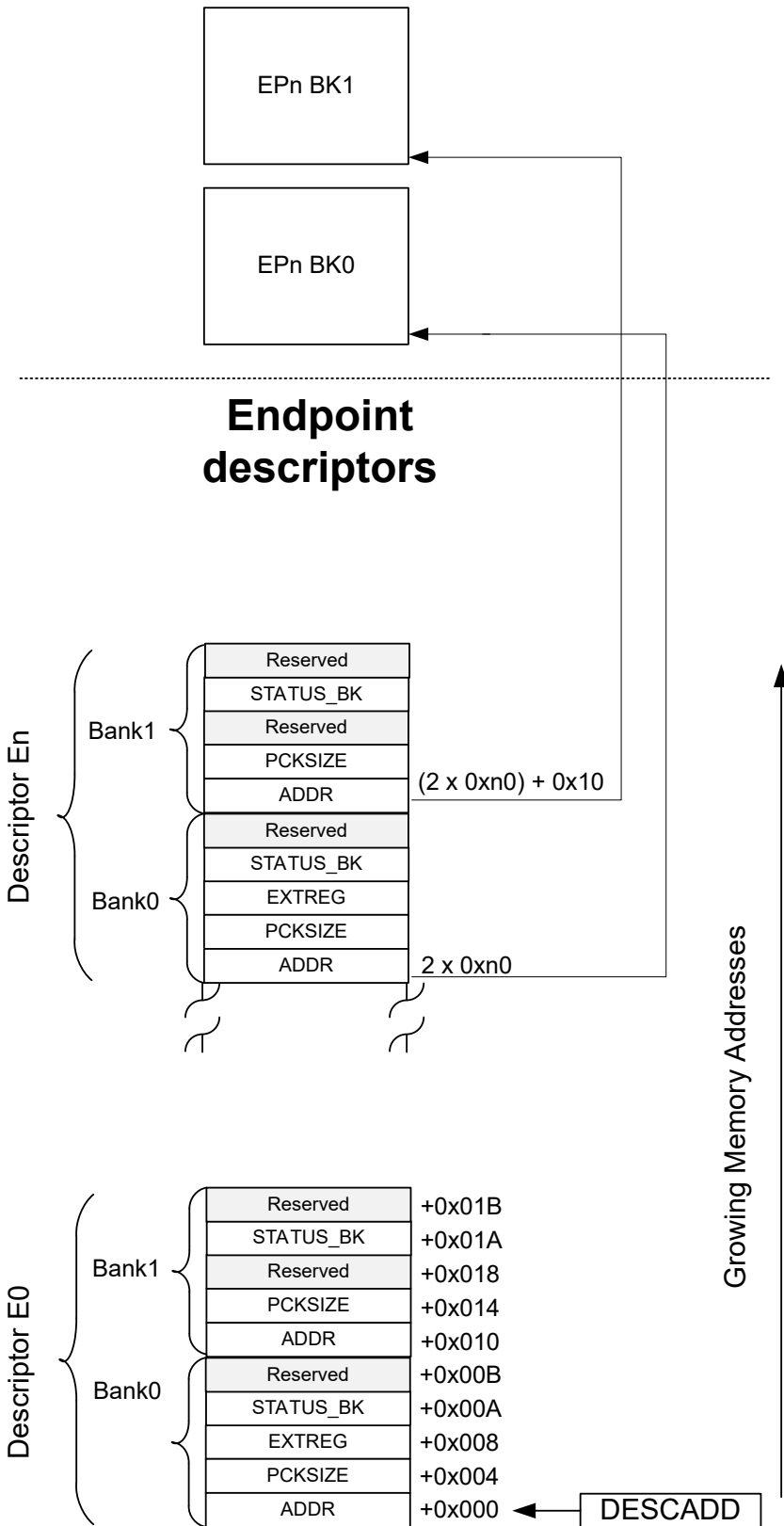
Writing a zero to this bit has no effect.

Writing a one to this bit will enable the Transfer Complete x interrupt.

0.2.4 Device Registers - Endpoint RAM

Value	Description
0	The Transfer Complete bank x interrupt is disabled.
1	The Transfer Complete bank x interrupt is enabled.

## 40.10 Endpoint Descriptors Structure Data Buffers



## 40.11 Device Endpoint n Descriptor Bank 0/1

Offset	Name	Bit Pos.	7	6	5	4	3	2	1	0
0x00	ADDR	7:0	ADDR[7:0]							
		15:8	ADDR[15:8]							
		23:16	ADDR[23:16]							
		31:24	ADDR[31:24]							
0x04	PCKSIZE	7:0	BYTE_COUNT[7:0]							
		15:8	MULTI_PACKET_SIZE[1:0]	BYTE_COUNT[13:8]						
		23:16	MULTI_PACKET_SIZE[9:2]							
		31:24	AUTO_ZLP	SIZE[2:0]			MULTI_PACKET_SIZE[13:10]			
0x08	EXTREG	7:0	VARIABLE[3:0]				SUBPID[3:0]			
		15:8	VARIABLE[10:4]							
0x0A	STATUS_BK	7:0							ERRORFLOW	CRCERR
0x0B ... 0x0F	Reserved									
0x10	ADDR	7:0	ADDR[7:0]							
		15:8	ADDR[15:8]							
		23:16	ADDR[23:16]							
		31:24	ADDR[31:24]							
0x14	PCKSIZE	7:0	BYTE_COUNT[7:0]							
		15:8	MULTI_PACKET_SIZE[1:0]	BYTE_COUNT[13:8]						
		23:16	MULTI_PACKET_SIZE[9:2]							
		31:24	AUTO_ZLP	SIZE[2:0]			MULTI_PACKET_SIZE[13:10]			
0x18 ... 0x19	Reserved									
0x1A	STATUS_BK	7:0							ERRORFLOW	CRCERR

### 40.11.1 Address of Data Buffer

**Name:** ADDR  
**Offset:** 0x00 + n\*0x10 [n=0..1]  
**Reset:** 0XXXXXXXX  
**Property:** -

Bit	31	30	29	28	27	26	25	24
	ADDR[31:24]							
Access	R/W	R/W	R/W	R/W	R/W	R/W	R/W	R/W
Reset	x	x	x	x	x	x	x	x
Bit	23	22	21	20	19	18	17	16
	ADDR[23:16]							
Access	R/W	R/W	R/W	R/W	R/W	R/W	R/W	R/W
Reset	x	x	x	x	x	x	x	x
Bit	15	14	13	12	11	10	9	8
	ADDR[15:8]							
Access	R/W	R/W	R/W	R/W	R/W	R/W	R/W	R/W
Reset	x	x	x	x	x	x	x	x
Bit	7	6	5	4	3	2	1	0
	ADDR[7:0]							
Access	R/W	R/W	R/W	R/W	R/W	R/W	R/W	R/W
Reset	x	x	x	x	x	x	x	x

#### Bits 31:0 – ADDR[31:0] Data Pointer Address Value

These bits define the data pointer address as an absolute word address in RAM. The two least significant bits must be zero to ensure the start address is 32-bit aligned.



## 40.11.2 Packet Size

**Name:** PCKSIZE  
**Offset:** 0x04 + n\*0x10 [n=0..1]  
**Reset:** 0XXXXXXXXX  
**Property:** -

Bit	31	30	29	28	27	26	25	24
	AUTO_ZLP	SIZE[2:0]			MULTI_PACKET_SIZE[13:10]			
Access	R/W	R/W	R/W	R/W	R/W	R/W	R/W	R/W
Reset	x	0	0	x	0	0	0	0
Bit	23	22	21	20	19	18	17	16
	MULTI_PACKET_SIZE[9:2]							
Access	R/W	R/W	R/W	R/W	R/W	R/W	R/W	R/W
Reset	0	0	0	0	0	0	0	0
Bit	15	14	13	12	11	10	9	8
	MULTI_PACKET_SIZE[1:0]		BYTE_COUNT[13:8]					
Access	R/W	R/W	R/W	R/W	R/W	R/W	R/W	R/W
Reset	0	x	0	0	0	0	0	0
Bit	7	6	5	4	3	2	1	0
	BYTE_COUNT[7:0]							
Access	R/W	R/W	R/W	R/W	R/W	R/W	R/W	R/W
Reset	0	0	0	0	0	0	0	x

### Bit 31 – AUTO\_ZLP Automatic Zero Length Packet

This bit defines the automatic Zero Length Packet mode of the endpoint. When enabled, the USB module will manage the ZLP handshake by hardware. This bit is for IN endpoints only. When disabled the handshake should be managed by firmware.

Value	Description
0	Automatic Zero Length Packet is disabled.
1	Automatic Zero Length Packet is enabled.

### Bits 30:28 – SIZE[2:0] Endpoint size

These bits contains the maximum packet size of the endpoint.

Value	Description
0x0	8 Byte
0x1	16 Byte
0x2	32 Byte
0x3	64 Byte
0x4	128 Byte <sup>(1)</sup>
0x5	256 Byte <sup>(1)</sup>
0x6	512 Byte <sup>(1)</sup>
0x7	1023 Byte <sup>(1)</sup>
<b>Note:</b> 1. For isochronous endpoint only.	

### Bits 27:14 – MULTI\_PACKET\_SIZE[13:0] Multiple Packet Size

These bits define the 14-bit value that is used for multi-packet transfers. For IN endpoints, MULTI\_PACKET\_SIZE holds the total number of bytes sent. MULTI\_PACKET\_SIZE should be written to zero when setting up a new transfer.

For OUT endpoints, MULTI\_PACKET\_SIZE holds the total data size for the complete transfer. This value must be a multiple of the maximum packet size.

**Bits 13:0 – BYTE\_COUNT[13:0]** Byte Count

These bits define the 14-bit value that is used for the byte count.

For IN endpoints, BYTE\_COUNT holds the number of bytes to be sent in the next IN transaction.

For OUT endpoint or SETUP endpoints, BYTE\_COUNT holds the number of bytes received upon the last OUT or SETUP transaction.

### 40.11.3 Extended Register

**Name:** EXTREG  
**Offset:** 0x08  
**Reset:** 0xFFFFFFFF  
**Property:** -

Bit	15	14	13	12	11	10	9	8
	VARIABLE[10:4]							
Access		R/W	R/W	R/W	R/W	R/W	R/W	R/W
Reset		0	0	0	0	0	0	0
Bit	7	6	5	4	3	2	1	0
	VARIABLE[3:0]				SUBPID[3:0]			
Access	R/W	R/W	R/W	R/W	R/W	R/W	R/W	R/W
Reset	0	0	0	x	0	0	0	x

#### Bits 14:4 – VARIABLE[10:0] Variable field send with extended token

These bits define the VARIABLE field of a received extended token. These bits are updated when the USB has answered by an handshake token ACK to a LPM transaction. See Section 2.1.1 Protocol Extension Token in the reference document “ENGINEERING CHANGE NOTICE, USB 2.0 Link Power Management Addendum”.

To support the USB2.0 Link Power Management addition the VARIABLE field should be read as described below.

VARIABLES	Description
VARIABLE[3:0]	bLinkState (1)
VARIABLE[7:4]	BESL (2)
VARIABLE[8]	bRemoteWake (1)
VARIABLE[10:9]	Reserved

1. For a definition of LPM Token bRemoteWake and bLinkState fields, refer to "Table 2-3 in the reference document ENGINEERING CHANGE NOTICE, USB 2.0 Link Power Management Addendum".
2. For a definition of LPM Token BESL field, refer to "Table 2-3 in the reference document ENGINEERING CHANGE NOTICE, USB 2.0 Link Power Management Addendum" and "Table X-X1 in Errata for ECN USB 2.0 Link Power Management.

#### Bits 3:0 – SUBPID[3:0] SUBPID field send with extended token

These bits define the SUBPID field of a received extended token. These bits are updated when the USB has answered by an handshake token ACK to a LPM transaction. See Section 2.1.1 Protocol Extension Token in the reference document “ENGINEERING CHANGE NOTICE, USB 2.0 Link Power Management Addendum”.

#### 40.11.4 Device Status Bank

**Name:** STATUS\_BK  
**Offset:** 0x0A + n\*0x10 [n=0..1]  
**Reset:** 0XXXXXXXX  
**Property:** -

Bit	7	6	5	4	3	2	1	0
							ERRORFLOW	CRCERR
Access							R/W	R/W
Reset							x	x

##### Bit 1 – ERRORFLOW Error Flow Status

This bit defines the Error Flow Status.

This bit is set when a Error Flow has been detected during transfer from/towards this bank.

For OUT transfer, a NAK handshake has been sent.

For Isochronous OUT transfer, an overrun condition has occurred.

For IN transfer, this bit is not valid. EPSTATUS.TRFAIL0 and EPSTATUS.TRFAIL1 should reflect the flow errors.

Value	Description
0	No Error Flow detected.
1	A Error Flow has been detected.

##### Bit 0 – CRCERR CRC Error

This bit defines the CRC Error Status.

This bit is set when a CRC error has been detected in an isochronous OUT endpoint bank.

##### 0.2.5 Host Registers - Common

Value	Description
0	No CRC Error.
1	CRC Error detected.

## 40.12 General Host Register Summary

Offset	Name	Bit Pos.	7	6	5	4	3	2	1	0	
0x00 ... 0x07	Reserved										
0x08	CTRLB	7:0				AUTORESUM E	SPDCONF[1:0]		RESUME		
		15:8					L1RESUME	VBUSOK	BUSRESET	SOFE	
0x0A	HSOFC	7:0	FLENCE				FLENC[3:0]				
0x0B	Reserved										
0x0C	STATUS	7:0	LINESTATE[1:0]				SPEED[1:0]				
0x0D ... 0x0F	Reserved										
0x10	FNUM	7:0	FNUM[4:0]								
		15:8	FNUM[10:5]								
0x12	FLENHIGH	7:0	FLENHIGH[7:0]								
0x13	Reserved										
0x14	INTENCLR	7:0	RAMACER	UPRSM	DNRSM	WAKEUP	RST	HSOF			
		15:8							DDISC	DCONN	
0x16 ... 0x17	Reserved										
0x18	INTENSET	7:0	RAMACER	UPRSM	DNRSM	WAKEUP	RST	HSOF			
		15:8							DDISC	DCONN	
0x1A ... 0x1B	Reserved										
0x1C	INTFLAG	7:0	RAMACER	UPRSM	DNRSM	WAKEUP	RST	HSOF			
		15:8							DDISC	DCONN	
0x1E ... 0x1F	Reserved										
0x20	PINTSMRY	7:0	EPINT7	EPINT6	EPINT5	EPINT4	EPINT3	EPINT2	EPINT1	EPINT0	
		15:8									

## 40.12.1 Control B

**Name:** CTRLB  
**Offset:** 0x08  
**Reset:** 0x0000  
**Property:** PAC Write-Protection

Bit	15	14	13	12	11	10	9	8
					L1RESUME	VBUSOK	BUSRESET	SOFE
Access					R/W	R/W	R/W	R/W
Reset					0	0	0	0
Bit	7	6	5	4	3	2	1	0
				AUTORESUME	SPDCONF[1:0]		RESUME	
Access				R/W	R/W	R/W	R/W	
Reset				0	0	0	0	

**Bit 11 - L1RESUME** Send USB L1 Resume  
 Writing 0 to this bit has no effect.  
 1: Generates a USB L1 Resume on the USB bus. This bit should only be set when the Start-of-Frame generation is enabled (SOFE bit set). The duration of the USB L1 Resume is defined by the EXTREG.VARIABLE[7:4] bits field also known as BESL (See LPM ECN). See the EXTREG Register. This bit is cleared when the USB L1 Resume has been sent or when a USB reset is requested.

**Bit 10 - VBUSOK** VBUS is OK  
 This notifies the USB HOST that USB operations can be started. When this bit is zero and even if the USB HOST is configured and enabled, HOST operation is halted. Setting this bit will allow HOST operation when the USB is configured and enabled.

Value	Description
0	The USB module is notified that the VBUS on the USB line is not powered.
1	The USB module is notified that the VBUS on the USB line is powered.

**Bit 9 - BUSRESET** Send USB Reset

Value	Description
0	Reset generation is disabled. It is written to zero when the USB reset is completed or when a device disconnection is detected. Writing zero has no effect.
1	Generates a USB Reset on the USB bus.

**Bit 8 - SOFE** Start-of-Frame Generation Enable

Value	Description
0	The SOF generation is disabled and the USB bus is in suspend state.
1	Generates SOF on the USB bus in full speed and keep it alive in low speed mode. This bit is automatically set at the end of a USB reset (INTFLAG.RST) or at the end of a downstream resume (INTFLAG.DNRSM) or at the end of L1 resume.

**Bit 4 - AUTORESUME** Auto Resume Enable

Value	Description
0	The Auto Resume is disabled.
1	Enable Auto Resume

**Bits 3:2 - SPDCONF[1:0]** Speed Configuration for Host

These bits select the host speed configuration as shown below

Value	Name	Description
0x0	NORMAL	Low and Full Speed capable

Value	Name	Description
0x1	-	Reserved
0x2	-	Reserved
0x3	-	Reserved

**Bit 1 – RESUME** Send USB Resume

Writing 0 to this bit has no effect.

1: Generates a USB Resume on the USB bus.

This bit is cleared when the USB Resume has been sent or when a USB reset is requested.

## 40.12.2 Host Start-of-Frame Control

**Name:** HSOFC  
**Offset:** 0x0A  
**Reset:** 0x00  
**Property:** PAC Write-Protection

During a very short period just before transmitting a Start-of-Frame, this register is locked. Thus, after writing, it is recommended to check the register value, and write this register again if necessary. This register is cleared upon a USB reset.

Bit	7	6	5	4	3	2	1	0
	FLENCE				FLENC[3:0]			
Access	R/W				R/W	R/W	R/W	R/W
Reset	0				0	0	0	0

### Bit 7 – FLENCE Frame Length Control Enable

When this bit is '1', the time between Start-of-Frames can be tuned by up to +/-0.06% using FLENC[3:0].

**Note:** In Low Speed mode, FLENCE must be '0'.

Value	Description
0	Start-of-Frame is generated every 1ms.
1	Start-of-Frame generation depends on the signed value of FLENC[3:0]. USB Start-of-Frame period equals 1ms + (FLENC[3:0]/12000)ms

### Bits 3:0 – FLENC[3:0] Frame Length Control

These bits define the signed value of the 4-bit FLENC that is added to the Internal Frame Length when FLENCE is '1'. The internal Frame length is the top value of the frame counter when FLENCE is zero.



### 40.12.3 Status

**Name:** STATUS  
**Offset:** 0x0C  
**Reset:** 0x00  
**Property:** Read only

Bit	7	6	5	4	3	2	1	0
	LINESTATE[1:0]				SPEED[1:0]			
Access	R	R			R/W	R/W		
Reset	0	0			0	0		

#### Bits 7:6 – LINESTATE[1:0] USB Line State Status

These bits define the current line state DP/DM.

LINESTATE[1:0]	USB Line Status
0x0	SE0/RESET
0x1	FS-J or LS-K State
0x2	FS-K or LS-J State

#### Bits 3:2 – SPEED[1:0] Speed Status

These bits define the current speed used by the host.

SPEED[1:0]	Speed Status
0x0	Full-speed mode
0x1	Low-speed mode
0x2	Reserved
0x3	Reserved

#### 40.12.4 Host Frame Number

**Name:** FNUM  
**Offset:** 0x10  
**Reset:** 0x0000  
**Property:** PAC Write-Protection

Bit	15	14	13	12	11	10	9	8
			FNUM[10:5]					
Access			R/W	R/W	R/W	R/W	R/W	R/W
Reset			0	0	0	0	0	0
Bit	7	6	5	4	3	2	1	0
	FNUM[4:0]							
Access	R/W	R/W	R/W	R/W	R/W			
Reset	0	0	0	0	0			

##### Bits 13:3 – FNUM[10:0] Frame Number

These bits contains the current SOF number.

These bits can be written by software to initialize a new frame number value. In this case, at the next SOF, the FNUM field takes its new value and the MFNUM bits are cleared.

As the FNUM register lies across two consecutive byte addresses, writing byte-wise (8-bits) to the FNUM register may produce incorrect frame number generation. It is recommended to write FNUM register word-wise (32-bits) or half-word-wise (16-bits).

### 40.12.5 Host Frame Length

**Name:** FLENHIGH  
**Offset:** 0x12  
**Reset:** 0x00  
**Property:** Read-Only

Bit	7	6	5	4	3	2	1	0
	FLENHIGH[7:0]							
Access	R	R	R	R	R	R	R	R
Reset	0	0	0	0	0	0	0	0

#### Bits 7:0 – FLENHIGH[7:0] Frame Length

These bits contains the 8 high-order bits of the internal frame counter.

**Table 40-1.** Counter Description vs. Speed

Host Register STATUS.SPEED	Description
Full Speed	With a USB clock running at 12 MHz, counter length is 12000 to ensure a SOF generation every 1 ms.

## 40.12.6 Host Interrupt Enable Register Clear

**Name:** INTENCLR  
**Offset:** 0x14  
**Reset:** 0x0000  
**Property:** PAC Write-Protection

This register allows the user to disable an interrupt without doing a read-modify-write operation. Changes in this register will also be reflected in the Interrupt Enable Set (INTENSET) register.

Bit	15	14	13	12	11	10	9	8
							DDISC	DCONN
Access							R/W	R/W
Reset							0	0
Bit	7	6	5	4	3	2	1	0
	RAMACER	UPRSM	DNRSM	WAKEUP	RST	HSOF		
Access	R/W	R/W	R/W	R/W	R/W	R/W		
Reset	0	0	0	0	0	0		

### Bit 9 – DDISC Device Disconnection Interrupt Disable

Writing a zero to this bit has no effect.

Writing a one to this bit will clear the Device Disconnection interrupt Enable bit and disable the corresponding interrupt request.

Value	Description
0	The Device Disconnection interrupt is disabled.
1	The Device Disconnection interrupt is enabled and an interrupt request will be generated when the Device Disconnection interrupt Flag is set.

### Bit 8 – DCONN Device Connection Interrupt Disable

Writing a zero to this bit has no effect.

Writing a one to this bit will clear the Device Connection interrupt Enable bit and disable the corresponding interrupt request.

Value	Description
0	The Device Connection interrupt is disabled.
1	The Device Connection interrupt is enabled and an interrupt request will be generated when the Device Connection interrupt Flag is set.

### Bit 7 – RAMACER RAM Access Interrupt Disable

Writing a zero to this bit has no effect.

Writing a one to this bit will clear the RAM Access interrupt Enable bit and disable the corresponding interrupt request.

Value	Description
0	The RAM Access interrupt is disabled.
1	The RAM Access interrupt is enabled and an interrupt request will be generated when the RAM Access interrupt Flag is set.

### Bit 6 – UPRSM Upstream Resume from Device Interrupt Disable

Writing a zero to this bit has no effect.

Writing a one to this bit will clear the Upstream Resume interrupt Enable bit and disable the corresponding interrupt request.

Value	Description
0	The Upstream Resume interrupt is disabled.
1	The Upstream Resume interrupt is enabled and an interrupt request will be generated when the Upstream Resume interrupt Flag is set.

**Bit 5 – DNRSM** Down Resume Interrupt Disable

Writing a zero to this bit has no effect.

Writing a one to this bit will clear the Down Resume interrupt Enable bit and disable the corresponding interrupt request.

Value	Description
0	The Down Resume interrupt is disabled.
1	The Down Resume interrupt is enabled and an interrupt request will be generated when the Down Resume interrupt Flag is set.

**Bit 4 – WAKEUP** Wake Up Interrupt Disable

Writing a zero to this bit has no effect.

Writing a one to this bit will clear the Wake Up interrupt Enable bit and disable the corresponding interrupt request.

Value	Description
0	The Wake Up interrupt is disabled.
1	The Wake Up interrupt is enabled and an interrupt request will be generated when the Wake Up interrupt Flag is set.

**Bit 3 – RST** BUS Reset Interrupt Disable

Writing a zero to this bit has no effect.

Writing a one to this bit will clear the Bus Reset interrupt Enable bit and disable the corresponding interrupt request.

Value	Description
0	The Bus Reset interrupt is disabled.
1	The Bus Reset interrupt is enabled and an interrupt request will be generated when the Bus Reset interrupt Flag is set.

**Bit 2 – HSOF** Host Start-of-Frame Interrupt Disable

Writing a zero to this bit has no effect.

Writing a one to this bit will clear the Host Start-of-Frame interrupt Enable bit and disable the corresponding interrupt request.

Value	Description
0	The Host Start-of-Frame interrupt is disabled.
1	The Host Start-of-Frame interrupt is enabled and an interrupt request will be generated when the Host Start-of-Frame interrupt Flag is set.

## 40.12.7 Host Interrupt Enable Register Set

**Name:** INTENSET  
**Offset:** 0x18  
**Reset:** 0x0000  
**Property:** PAC Write-Protection

This register allows the user to enable an interrupt without doing a read-modify-write operation. Changes in this register will also be reflected in the Interrupt Enable Clear (INTENCLR) register.

Bit	15	14	13	12	11	10	9	8
							DDISC	DCONN
Access							R/W	R/W
Reset							0	0
Bit	7	6	5	4	3	2	1	0
	RAMACER	UPRSM	DNRSM	WAKEUP	RST	HSOF		
Access	R/W	R/W	R/W	R/W	R/W	R/W		
Reset	0	0	0	0	0	0		

### Bit 9 – DDISC Device Disconnection Interrupt Enable

Writing a zero to this bit has no effect.

Writing a one to this bit will set the Device Disconnection interrupt bit and enable the DDSIC interrupt.

Value	Description
0	The Device Disconnection interrupt is disabled.
1	The Device Disconnection interrupt is enabled.

### Bit 8 – DCONN Device Connection Interrupt Enable

Writing a zero to this bit has no effect.

Writing a one to this bit will set the Device Connection interrupt bit and enable the DCONN interrupt.

Value	Description
0	The Device Connection interrupt is disabled.
1	The Device Connection interrupt is enabled.

### Bit 7 – RAMACER RAM Access Interrupt Enable

Writing a zero to this bit has no effect.

Writing a one to this bit will set the RAM Access interrupt bit and enable the RAMACER interrupt.

Value	Description
0	The RAM Access interrupt is disabled.
1	The RAM Access interrupt is enabled.

### Bit 6 – UPRSM Upstream Resume from the device Interrupt Enable

Writing a zero to this bit has no effect.

Writing a one to this bit will set the Upstream Resume interrupt bit and enable the UPRSM interrupt.

Value	Description
0	The Upstream Resume interrupt is disabled.
1	The Upstream Resume interrupt is enabled.

### Bit 5 – DNRSM Down Resume Interrupt Enable

Writing a zero to this bit has no effect.

Writing a one to this bit will set the Down Resume interrupt Enable bit and enable the DNRSM interrupt.

Value	Description
0	The Down Resume interrupt is disabled.

Value	Description
1	The Down Resume interrupt is enabled.

**Bit 4 - WAKEUP** Wake Up Interrupt Enable

Writing a zero to this bit has no effect.

Writing a one to this bit will set the Wake Up interrupt Enable bit and enable the WAKEUP interrupt request.

Value	Description
0	The WakeUp interrupt is disabled.
1	The WakeUp interrupt is enabled.

**Bit 3 - RST** Bus Reset Interrupt Enable

Writing a zero to this bit has no effect.

Writing a one to this bit will set the Bus Reset interrupt Enable bit and enable the Bus RST interrupt.

Value	Description
0	The Bus Reset interrupt is disabled.
1	The Bus Reset interrupt is enabled.

**Bit 2 - HSOF** Host Start-of-Frame Interrupt Enable

Writing a zero to this bit has no effect.

Writing a one to this bit will set the Host Start-of-Frame interrupt Enable bit and enable the HSOF interrupt.

Value	Description
0	The Host Start-of-Frame interrupt is disabled.
1	The Host Start-of-Frame interrupt is enabled.

## 40.12.8 Host Interrupt Flag Status and Clear

**Name:** INTFLAG  
**Offset:** 0x1C  
**Reset:** 0x0000  
**Property:** -

Bit	15	14	13	12	11	10	9	8
							DDISC	DCONN
Access							R/W	R/W
Reset							0	0
Bit	7	6	5	4	3	2	1	0
	RAMACER	UPRSM	DNRSM	WAKEUP	RST	HSOF		
Access	R/W	R/W	R/W	R/W	R/W	R/W		
Reset	0	0	0	0	0	0		

### Bit 9 – DDISC Device Disconnection Interrupt Flag

This flag is cleared by writing a one to the flag.

This flag is set when the device has been removed from the USB Bus and will generate an interrupt if INTENCLR/SET.DDISC is one.

Writing a zero to this bit has no effect.

Writing a one to this bit clears the DDISC Interrupt Flag.

### Bit 8 – DCONN Device Connection Interrupt Flag

This flag is cleared by writing a one to the flag.

This flag is set when a new device has been connected to the USB BUS and will generate an interrupt if INTENCLR/SET.DCONN is one.

Writing a zero to this bit has no effect.

Writing a one to this bit clears the DCONN Interrupt Flag.

### Bit 7 – RAMACER RAM Access Interrupt Flag

This flag is cleared by writing a one to the flag.

This flag is set when a RAM access error occurs during an OUT stage and will generate an interrupt if INTENCLR/SET.RAMACER is one.

Writing a zero to this bit has no effect.

### Bit 6 – UPRSM Upstream Resume from the Device Interrupt Flag

This flag is cleared by writing a one to the flag.

This flag is set when the USB has received an Upstream Resume signal from the Device and will generate an interrupt if INTENCLR/SET.UPRSM is one.

Writing a zero to this bit has no effect.

### Bit 5 – DNRSM Down Resume Interrupt Flag

This flag is cleared by writing a one to the flag.

This flag is set when the USB has sent a Down Resume and will generate an interrupt if INTENCLR/SET.DRSM is one.

Writing a zero to this bit has no effect.

### Bit 4 – WAKEUP Wake Up Interrupt Flag

This flag is cleared by writing a one.

This flag is set when:

! The host controller is in suspend mode (SOFE is zero) and an upstream resume from the device is detected.



I The host controller is in suspend mode (SOFE is zero) and an device disconnection is detected.  
I The host controller is in operational state (VBUSOK is one) and an device connection is detected.  
In all cases it will generate an interrupt if INTENCLR/SET.WAKEUP is one.  
Writing a zero to this bit has no effect.

**Bit 3 – RST** Bus Reset Interrupt Flag

This flag is cleared by writing a one to the flag.

This flag is set when a Bus “Reset” has been sent to the Device and will generate an interrupt if INTENCLR/SET.RST is one.

Writing a zero to this bit has no effect.

**Bit 2 – HSOF** Host Start-of-Frame Interrupt Flag

This flag is cleared by writing a one to the flag.

This flag is set when a USB “Host Start-of-Frame” in Full Speed or a keep-alive in Low Speed has been sent (every 1 ms) and will generate an interrupt if INTENCLR/SET.HSOF is one.

The value of the FNUM register is updated.

Writing a zero to this bit has no effect.

### 40.12.9 Pipe Interrupt Summary

**Name:** PINTSMRY  
**Offset:** 0x20  
**Reset:** 0x0000  
**Property:** Read-only

Bit	15	14	13	12	11	10	9	8
Access								
Reset								
Bit	7	6	5	4	3	2	1	0
Access	R	R	R	R	R	R	R	R
Reset	0	0	0	0	0	0	0	0

#### Bits 0, 1, 2, 3, 4, 5, 6, 7 - EPINT

The flag EPINT<sub>n</sub> is set when an interrupt is triggered by the pipe n. See the [PINTFLAG](#) register in the Host Pipe Register section.  
 This bit will be cleared when there are no interrupts pending for Pipe n.  
 Writing to this bit has no effect.

## 40.13 Host Pipe n Register Summary

Offset	Name	Bit Pos.	7	6	5	4	3	2	1	0
0x00 ... 0xFF	Reserved									
0x0100	PCFG0	7:0				PTYPE[2:0]		BK	PTOKEN[1:0]	
0x0101 ... 0x0102	Reserved									
0x0103	BINTERVAL0	7:0	BINTERVAL[7:0]							
0x0104	PSTATUSCLR0	7:0	BK1RDY	BKORDY		PFREEZE		CURBK		DTGL
0x0105	PSTATUSSET0	7:0	BK1RDY	BKORDY		PFREEZE		CURBK		DTGL
0x0106	PSTATUS0	7:0	BK1RDY	BKORDY		PFREEZE		CURBK		DTGL
0x0107	PINTFLAG0	7:0			STALL	TXSTP	PERR	TRFAIL	TRCPT1	TRCPT0
0x0108	PINTENCLR0	7:0			STALL	TXSTP	PERR	TRFAIL	TRCPT1	TRCPT0
0x0109	PINTENSET0	7:0			STALL	TXSTP	PERR	TRFAIL	TRCPT1	TRCPT0
0x010A ... 0x011F	Reserved									
0x0120	PCFG1	7:0				PTYPE[2:0]		BK	PTOKEN[1:0]	
0x0121 ... 0x0122	Reserved									
0x0123	BINTERVAL1	7:0	BINTERVAL[7:0]							
0x0124	PSTATUSCLR1	7:0	BK1RDY	BKORDY		PFREEZE		CURBK		DTGL
0x0125	PSTATUSSET1	7:0	BK1RDY	BKORDY		PFREEZE		CURBK		DTGL
0x0126	PSTATUS1	7:0	BK1RDY	BKORDY		PFREEZE		CURBK		DTGL
0x0127	PINTFLAG1	7:0			STALL	TXSTP	PERR	TRFAIL	TRCPT1	TRCPT0
0x0128	PINTENCLR1	7:0			STALL	TXSTP	PERR	TRFAIL	TRCPT1	TRCPT0
0x0129	PINTENSET1	7:0			STALL	TXSTP	PERR	TRFAIL	TRCPT1	TRCPT0
0x012A ... 0x013F	Reserved									
0x0140	PCFG2	7:0				PTYPE[2:0]		BK	PTOKEN[1:0]	
0x0141 ... 0x0142	Reserved									
0x0143	BINTERVAL2	7:0	BINTERVAL[7:0]							
0x0144	PSTATUSCLR2	7:0	BK1RDY	BKORDY		PFREEZE		CURBK		DTGL
0x0145	PSTATUSSET2	7:0	BK1RDY	BKORDY		PFREEZE		CURBK		DTGL
0x0146	PSTATUS2	7:0	BK1RDY	BKORDY		PFREEZE		CURBK		DTGL
0x0147	PINTFLAG2	7:0			STALL	TXSTP	PERR	TRFAIL	TRCPT1	TRCPT0
0x0148	PINTENCLR2	7:0			STALL	TXSTP	PERR	TRFAIL	TRCPT1	TRCPT0
0x0149	PINTENSET2	7:0			STALL	TXSTP	PERR	TRFAIL	TRCPT1	TRCPT0
0x014A ... 0x015F	Reserved									
0x0160	PCFG3	7:0				PTYPE[2:0]		BK	PTOKEN[1:0]	
0x0161 ... 0x0162	Reserved									
0x0163	BINTERVAL3	7:0	BINTERVAL[7:0]							
0x0164	PSTATUSCLR3	7:0	BK1RDY	BKORDY		PFREEZE		CURBK		DTGL
0x0165	PSTATUSSET3	7:0	BK1RDY	BKORDY		PFREEZE		CURBK		DTGL
0x0166	PSTATUS3	7:0	BK1RDY	BKORDY		PFREEZE		CURBK		DTGL
0x0167	PINTFLAG3	7:0			STALL	TXSTP	PERR	TRFAIL	TRCPT1	TRCPT0
0x0168	PINTENCLR3	7:0			STALL	TXSTP	PERR	TRFAIL	TRCPT1	TRCPT0
0x0169	PINTENSET3	7:0			STALL	TXSTP	PERR	TRFAIL	TRCPT1	TRCPT0
0x016A ... 0x017F	Reserved									
0x0180	PCFG4	7:0				PTYPE[2:0]		BK	PTOKEN[1:0]	

.....continued										
Offset	Name	Bit Pos.	7	6	5	4	3	2	1	0
0x0181	Reserved									
...										
0x0182										
0x0183	BINTERVAL4	7:0	BINTERVAL[7:0]							
0x0184	PSTATUSCLR4	7:0	BK1RDY	BK0RDY		PFREEZE		CURBK		DTGL
0x0185	PSTATUSSET4	7:0	BK1RDY	BK0RDY		PFREEZE		CURBK		DTGL
0x0186	PSTATUS4	7:0	BK1RDY	BK0RDY		PFREEZE		CURBK		DTGL
0x0187	PINTFLAG4	7:0			STALL	TXSTP	PERR	TRFAIL	TRCPT1	TRCPT0
0x0188	PINTENCLR4	7:0			STALL	TXSTP	PERR	TRFAIL	TRCPT1	TRCPT0
0x0189	PINTENSET4	7:0			STALL	TXSTP	PERR	TRFAIL	TRCPT1	TRCPT0
0x018A	Reserved									
...										
0x019F										
0x01A0	PCFG5	7:0			PTYPE[2:0]			BK	PTOKEN[1:0]	
0x01A1	Reserved									
...										
0x01A2										
0x01A3	BINTERVAL5	7:0	BINTERVAL[7:0]							
0x01A4	PSTATUSCLR5	7:0	BK1RDY	BK0RDY		PFREEZE		CURBK		DTGL
0x01A5	PSTATUSSET5	7:0	BK1RDY	BK0RDY		PFREEZE		CURBK		DTGL
0x01A6	PSTATUS5	7:0	BK1RDY	BK0RDY		PFREEZE		CURBK		DTGL
0x01A7	PINTFLAG5	7:0			STALL	TXSTP	PERR	TRFAIL	TRCPT1	TRCPT0
0x01A8	PINTENCLR5	7:0			STALL	TXSTP	PERR	TRFAIL	TRCPT1	TRCPT0
0x01A9	PINTENSET5	7:0			STALL	TXSTP	PERR	TRFAIL	TRCPT1	TRCPT0
0x01AA	Reserved									
...										
0x01BF										
0x01C0	PCFG6	7:0			PTYPE[2:0]			BK	PTOKEN[1:0]	
0x01C1	Reserved									
...										
0x01C2										
0x01C3	BINTERVAL6	7:0	BINTERVAL[7:0]							
0x01C4	PSTATUSCLR6	7:0	BK1RDY	BK0RDY		PFREEZE		CURBK		DTGL
0x01C5	PSTATUSSET6	7:0	BK1RDY	BK0RDY		PFREEZE		CURBK		DTGL
0x01C6	PSTATUS6	7:0	BK1RDY	BK0RDY		PFREEZE		CURBK		DTGL
0x01C7	PINTFLAG6	7:0			STALL	TXSTP	PERR	TRFAIL	TRCPT1	TRCPT0
0x01C8	PINTENCLR6	7:0			STALL	TXSTP	PERR	TRFAIL	TRCPT1	TRCPT0
0x01C9	PINTENSET6	7:0			STALL	TXSTP	PERR	TRFAIL	TRCPT1	TRCPT0
0x01CA	Reserved									
...										
0x01DF										
0x01E0	PCFG7	7:0			PTYPE[2:0]			BK	PTOKEN[1:0]	
0x01E1	Reserved									
...										
0x01E2										
0x01E3	BINTERVAL7	7:0	BINTERVAL[7:0]							
0x01E4	PSTATUSCLR7	7:0	BK1RDY	BK0RDY		PFREEZE		CURBK		DTGL
0x01E5	PSTATUSSET7	7:0	BK1RDY	BK0RDY		PFREEZE		CURBK		DTGL
0x01E6	PSTATUS7	7:0	BK1RDY	BK0RDY		PFREEZE		CURBK		DTGL
0x01E7	PINTFLAG7	7:0			STALL	TXSTP	PERR	TRFAIL	TRCPT1	TRCPT0
0x01E8	PINTENCLR7	7:0			STALL	TXSTP	PERR	TRFAIL	TRCPT1	TRCPT0
0x01E9	PINTENSET7	7:0			STALL	TXSTP	PERR	TRFAIL	TRCPT1	TRCPT0

### 40.13.1 Host Pipe n Configuration

**Name:** PCFGn  
**Offset:** 0x0100 + n\*0x20 [n=0..7]  
**Reset:** 0x00  
**Property:** PAC Write-Protection

Bit	7	6	5	4	3	2	1	0
			PTYPE[2:0]			BK	PTOKEN[1:0]	
Access			R/W	R/W	R/W	R/W	R/W	R/W
Reset			0	0	0	0	0	0

**Bits 5:3 – PTYPE[2:0]** Type of the Pipe  
 These bits contains the pipe type.

PTYPE[2:0]	Description
0x0	Pipe is disabled
0x1	Pipe is enabled and configured as CONTROL
0x2	Pipe is enabled and configured as ISO
0x3	Pipe is enabled and configured as BULK
0x4	Pipe is enabled and configured as INTERRUPT
0x5	Pipe is enabled and configured as EXTENDED
0x06-0x7	Reserved

These bits are cleared upon sending a USB reset.

**Bit 2 – BK** Pipe Bank

This bit selects the number of banks for the pipe.  
 For control endpoints writing a zero to this bit is required as only Bank0 is used for Setup/In/Out transactions.  
 This bit is cleared when a USB reset is sent.

BK <sup>(1)</sup>	Description
0x0	Single-bank endpoint
0x1	Dual-bank endpoint

1. Bank field is ignored when PTYPE is configured as EXTENDED.

Value	Description
0	A single bank is used for the pipe.
1	A dual bank is used for the pipe.

**Bits 1:0 – PTOKEN[1:0]** Pipe Token

These bits contains the pipe token.

PTOKEN[1:0] <sup>(1)</sup>	Description
0x0	SETUP <sup>(2)</sup>
0x1	IN
0x2	OUT
0x3	Reserved

1. PTOKEN field is ignored when PTYPE is configured as EXTENDED.
2. Available only when PTYPE is configured as CONTROL

Theses bits are cleared upon sending a USB reset.

### 40.13.2 Interval for the Bulk-Out/Ping Transaction for Endpoint n

**Name:** BINTERVALn  
**Offset:** 0x0103 + n\*0x20 [n=0..7]  
**Reset:** 0x00  
**Property:** PAC Write-Protection

Bit	7	6	5	4	3	2	1	0
	BINTERVAL[7:0]							
Access	R/W	R/W	R/W	R/W	R/W	R/W	R/W	R/W
Reset	0	0	0	0	0	0	0	0

#### Bits 7:0 – BINTERVAL[7:0] BINTERVAL

These bits contains the Ping/Bulk-out period.

These bits are cleared when a USB reset is sent or when PEN[n] is zero.

BINTERVAL	Description
= 0	Multiple consecutive OUT token is sent in the same frame until it is acked by the peripheral
> 0	One OUT token is sent every BINTERVAL frame until it is acked by the peripheral

Depending on the type of pipe, the desired period is defined as follows:

PTYPE	Description
Interrupt	1 ms to 255 ms
Isochronous	$2^{(Binterval)} * 1 \text{ ms}$
Bulk or control	1 ms to 255 ms
EXT LPM	bInterval ignored. Always 1 ms when a NYET is received.

### 40.13.3 Pipe Status Clear n

**Name:** PSTATUSCLRn  
**Offset:** 0x0104 + n\*0x20 [n=0..7]  
**Reset:** 0x00  
**Property:** PAC Write-Protection

Bit	7	6	5	4	3	2	1	0
	BK1RDY	BKORDY		PFREEZE		CURBK		DTGL
Access	W	W		W		W		W
Reset	0	0		0		0		0

- Bit 7 – BK1RDY** Bank 1 Ready Clear  
 Writing a zero to this bit has no effect.  
 Writing a one to this bit will clear PSTATUS.BK1RDY bit.
- Bit 6 – BKORDY** Bank 0 Ready Clear  
 Writing a zero to this bit has no effect.  
 Writing a one to this bit will clear PSTATUS.BKORDY bit.
- Bit 4 – PFREEZE** Pipe Freeze Clear  
 Writing a zero to this bit has no effect.  
 Writing a one to this bit will clear PSTATUS.PFREEZE bit.
- Bit 2 – CURBK** Current Bank Clear  
 Writing a zero to this bit has no effect.  
 Writing a one to this bit will clear PSTATUS.CURBK bit.
- Bit 0 – DTGL** Data Toggle Clear  
 Writing a zero to this bit has no effect.  
 Writing a one to this bit will clear PSTATUS.DTGL bit.

#### 40.13.4 Pipe Status Set Register n

**Name:** PSTATUSSETn  
**Offset:** 0x0105 + n\*0x20 [n=0..7]  
**Reset:** 0x00  
**Property:** PAC Write-Protection

Bit	7	6	5	4	3	2	1	0
	BK1RDY	BKORDY		PFREEZE		CURBK		DTGL
Access	W	W		W		W		W
Reset	0	0		0		0		0

- Bit 7 – BK1RDY** Bank 1 Ready Set  
 Writing a zero to this bit has no effect.  
 Writing a one to this bit will set the bit PSTATUS.BK1RDY.
- Bit 6 – BKORDY** Bank 0 Ready Set  
 Writing a zero to this bit has no effect.  
 Writing a one to this bit will set the bit PSTATUS.BKORDY.
- Bit 4 – PFREEZE** Pipe Freeze Set  
 Writing a zero to this bit has no effect.  
 Writing a one to this bit will set PSTATUS.PFREEZE bit.
- Bit 2 – CURBK** Current Bank Set  
 Writing a zero to this bit has no effect.  
 Writing a one to this bit will set PSTATUS.CURBK bit.
- Bit 0 – DTGL** Data Toggle Set  
 Writing a zero to this bit has no effect.  
 Writing a one to this bit will set PSTATUS.DTGL bit.



### 40.13.5 Pipe Status Register n

**Name:** PSTATUSn  
**Offset:** 0x0106 + n\*0x20 [n=0..7]  
**Reset:** 0x00  
**Property:** PAC Write-Protection

Bit	7	6	5	4	3	2	1	0
	BK1RDY	BK0RDY		PFREEZE		CURBK		DTGL
Access	R	R		R		R		R
Reset	0	0		0		0		0

#### Bit 7 – BK1RDY Bank 1 is ready

Writing a one to the bit EPSTATUSCLR.BK1RDY will clear this bit.  
 Writing a one to the bit EPSTATUSSET.BK1RDY will set this bit.  
 This bank is not used for Control pipe.

Value	Description
0	The bank number 1 is not ready: For IN the bank is empty. For Control/OUT the bank is not yet fill in.
1	The bank number 1 is ready: For IN the bank is filled full. For Control/OUT the bank is filled in.

#### Bit 6 – BK0RDY Bank 0 is ready

Writing a one to the bit EPSTATUSCLR.BK0RDY will clear this bit.  
 Writing a one to the bit EPSTATUSSET.BK0RDY will set this bit.  
 This bank is the only one used for Control pipe.

Value	Description
0	The bank number 0 is not ready: For IN the bank is not empty. For Control/OUT the bank is not yet fill in.
1	The bank number 0 is ready: For IN the bank is filled full. For Control/OUT the bank is filled in.

#### Bit 4 – PFREEZE Pipe Freeze

Writing a one to the bit EPSTATUSCLR.PFREEZE will clear this bit.  
 Writing a one to the bit EPSTATUSSET.PFREEZE will set this bit.  
 This bit is also set by the hardware:

- When a STALL handshake has been received.
- After a PIPE has been enabled (rising of bit PEN.N).
- When an LPM transaction has completed whatever handshake is returned or the transaction was timed-out.
- When a pipe transfer was completed with a pipe error. See the [PINTFLAG](#) register.

When PFREEZE bit is set while a transaction is in progress on the USB bus, this transaction will be properly completed. PFREEZE bit will be read as “1” only when the ongoing transaction will have been completed.

Value	Description
0	The Pipe operates in normal operation.
1	The Pipe is frozen and no additional requests will be sent to the device on this pipe address.

#### Bit 2 – CURBK Current Bank

Value	Description
0	The bank0 is the bank that will be used in the next single/multi USB packet.
1	The bank1 is the bank that will be used in the next single/multi USB packet.

#### Bit 0 – DTGL Data Toggle Sequence

Writing a one to the bit EPSTATUSCLR.DTGL will clear this bit.  
 Writing a one to the bit EPSTATUSSET.DTGL will set this bit.

This bit is toggled automatically by hardware after a data transaction.  
This bit will reflect the data toggle in regards of the token type (IN/OUT/SETUP).

Value	Description
0	The PID of the next expected transaction will be zero: data 0.
1	The PID of the next expected transaction will be one: data 1.

### 40.13.6 Host Pipe Interrupt Flag Register

**Name:** PINTFLAGn  
**Offset:** 0x0107 + n\*0x20 [n=0..7]  
**Reset:** 0x00  
**Property:** -

Bit	7	6	5	4	3	2	1	0
Access			R/W	R/W	R/W	R/W	R/W	R/W
Reset			0	0	0	0	0	2

#### Bit 5 – STALL STALL Received Interrupt Flag

This flag is cleared by writing a one to the flag.  
 This flag is set when a stall occurs and will generate an interrupt if PINTENCLR/SET.STALL is one.  
 Writing a zero to this bit has no effect.  
 Writing a one to this bit clears the STALL Interrupt Flag.

#### Bit 4 – TXSTP Transmitted Setup Interrupt Flag

This flag is cleared by writing a one to the flag.  
 This flag is set when a Transfer Complete occurs and will generate an interrupt if PINTENCLR/SET.TXSTP is one.  
 Writing a zero to this bit has no effect.  
 Writing a one to this bit clears the TXSTP Interrupt Flag.

#### Bit 3 – PERR Pipe Error Interrupt Flag

This flag is cleared by writing a one to the flag.  
 This flag is set when a pipe error occurs and will generate an interrupt if PINTENCLR/SET.PERR is one.  
 Writing a zero to this bit has no effect.  
 Writing a one to this bit clears the PERR Interrupt Flag.

#### Bit 2 – TRFAIL Transfer Fail Interrupt Flag

This flag is cleared by writing a one to the flag.  
 This flag is set when a Transfer Fail occurs and will generate an interrupt if PINTENCLR/SET.TRFAIL is one.  
 Writing a zero to this bit has no effect.  
 Writing a one to this bit clears the TRFAIL Interrupt Flag.

#### Bits 0, 1 – TRCPT Transfer Complete x interrupt Flag

This flag is cleared by writing a one to the flag.  
 This flag is set when a Transfer complete occurs and will generate an interrupt if PINTENCLR/SET.TRCPT is one. PINTFLAG.TRCPT is set for a single bank IN/OUT pipe or a double bank IN/OUT pipe when current bank is 0.  
 Writing a zero to this bit has no effect.  
 Writing a one to this bit clears the TRCPT Interrupt Flag.

### 40.13.7 Host Pipe Interrupt Clear Register

**Name:** PINTENCLRn  
**Offset:** 0x0108 + n\*0x20 [n=0..7]  
**Reset:** 0x00  
**Property:** PAC Write-Protection

This register allows the user to disable an interrupt without doing a read-modify-write operation. Changes in this register will also be reflected in the Pipe Interrupt Enable Set (PINTENSET) register.

This register is cleared by USB reset or when PEN[n] is zero.

Bit	7	6	5	4	3	2	1	0
Access			R/W	R/W	R/W	R/W	R/W	R/W
Reset			0	0	0	0	0	2

#### Bit 5 – STALL Received Stall Interrupt Disable

Writing a zero to this bit has no effect.

Writing a one to this bit will clear the Received Stall interrupt Enable bit and disable the corresponding interrupt request.

Value	Description
0	The received Stall interrupt is disabled.
1	The received Stall interrupt is enabled and an interrupt request will be generated when the received Stall interrupt Flag is set.

#### Bit 4 – TXSTP Transmitted Setup Interrupt Disable

Writing a zero to this bit has no effect.

Writing a one to this bit will clear the Transmitted Setup interrupt Enable bit and disable the corresponding interrupt request.

Value	Description
0	The Transmitted Setup interrupt is disabled.
1	The Transmitted Setup interrupt is enabled and an interrupt request will be generated when the Transmitted Setup interrupt Flag is set.

#### Bit 3 – PERR Pipe Error Interrupt Disable

Writing a zero to this bit has no effect.

Writing a one to this bit will clear the Pipe Error interrupt Enable bit and disable the corresponding interrupt request.

Value	Description
0	The Pipe Error interrupt is disabled.
1	The Pipe Error interrupt is enabled and an interrupt request will be generated when the Pipe Error interrupt Flag is set.

#### Bit 2 – TRFAIL Transfer Fail Interrupt Disable

Writing a zero to this bit has no effect.

Writing a one to this bit will clear the Transfer Fail interrupt Enable bit and disable the corresponding interrupt request.

Value	Description
0	The Transfer Fail interrupt is disabled.
1	The Transfer Fail interrupt is enabled and an interrupt request will be generated when the Transfer Fail interrupt Flag is set.

#### Bits 0, 1 – TRCPT Transfer Complete Bank x interrupt Disable

Writing a zero to this bit has no effect.

Writing a one to this bit will clear the Transfer Complete interrupt Enable bit x and disable the corresponding interrupt request.

Value	Description
0	The Transfer Complete Bank x interrupt is disabled.
1	The Transfer Complete Bank x interrupt is enabled and an interrupt request will be generated when the Transfer Complete interrupt x Flag is set.

### 40.13.8 Host Interrupt Pipe Set Register

**Name:** PINTENSETn  
**Offset:** 0x0109 + n\*0x20 [n=0..7]  
**Reset:** 0x00  
**Property:** PAC Write-Protection

This register allows the user to enable an interrupt without doing a read-modify-write operation. Changes in this register will also be reflected in the Pipe Interrupt Enable Set (PINTENCLR) register.

This register is cleared by USB reset or when PEN[n] is zero.

Bit	7	6	5	4	3	2	1	0
Access			R/W	R/W	R/W	R/W	R/W	R/W
Reset			0	0	0	0	0	2

#### Bit 5 – STALL Stall Interrupt Enable

Writing a zero to this bit has no effect.  
 Writing a one to this bit will enable the Stall interrupt.

Value	Description
0	The Stall interrupt is disabled.
1	The Stall interrupt is enabled.

#### Bit 4 – TXSTP Transmitted Setup Interrupt Enable

Writing a zero to this bit has no effect.  
 Writing a one to this bit will enable the Transmitted Setup interrupt.

Value	Description
0	The Transmitted Setup interrupt is disabled.
1	The Transmitted Setup interrupt is enabled.

#### Bit 3 – PERR Pipe Error Interrupt Enable

Writing a zero to this bit has no effect.  
 Writing a one to this bit will enable the Pipe Error interrupt.

Value	Description
0	The Pipe Error interrupt is disabled.
1	The Pipe Error interrupt is enabled.

#### Bit 2 – TRFAIL Transfer Fail Interrupt Enable

Writing a zero to this bit has no effect.  
 Writing a one to this bit will enable the Transfer Fail interrupt.

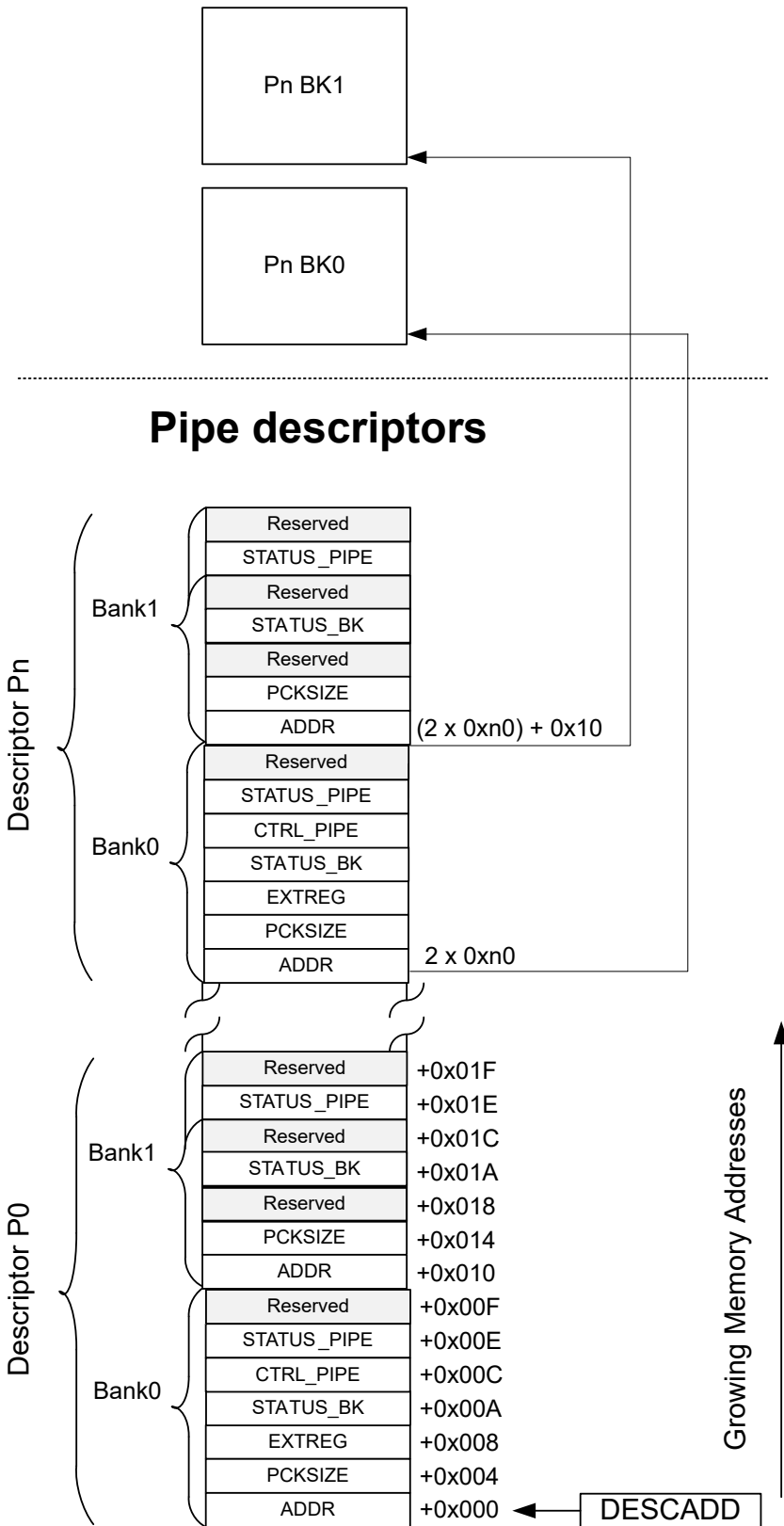
Value	Description
0	The Transfer Fail interrupt is disabled.
1	The Transfer Fail interrupt is enabled.

#### Bits 0, 1 – TRCPT Transfer Complete x interrupt Enable

Writing a zero to this bit has no effect.  
 Writing a one to this bit will enable the Transfer Complete interrupt Enable bit x.

Value	Description
0	The Transfer Complete x interrupt is disabled.
1	The Transfer Complete x interrupt is enabled.

## 40.14 Pipe Descriptors Structure Data Buffers



## 40.15 Host Pipe n Descriptor Bank 0 / 1

Offset	Name	Bit Pos.	7	6	5	4	3	2	1	0		
0x00	ADDR	7:0	ADDR[7:0]									
		15:8	ADDR[15:8]									
		23:16	ADDR[23:16]									
		31:24	ADDR[31:24]									
0x04	PCKSIZE	7:0	BYTE_COUNT[7:0]									
		15:8	MULTI_PACKET_SIZE[1:0]	BYTE_COUNT[13:8]								
		23:16	MULTI_PACKET_SIZE[9:2]									
		31:24	AUTO_ZLP	SIZE[2:0]			MULTI_PACKET_SIZE[13:10]					
0x08	EXTREG	7:0	VARIABLE[3:0]				SUBPID[3:0]					
		15:8	VARIABLE[10:4]									
0x0A	STATUS_BK	7:0								ERRORFLOW	CRCERR	
0x0B	Reserved											
0x0C	CTRL_PIPE	7:0	PDADDR[6:0]									
		15:8	PERMAX[3:0]			PEPNUM[3:0]						
0x0E	STATUS_PIPE	7:0	ERCNT[2:0]		CRC16ER	TOUTER	PIDER	DAPIDER	DTGLER			
		15:8										
0x10	ADDR	7:0	ADDR[7:0]									
		15:8	ADDR[15:8]									
		23:16	ADDR[23:16]									
		31:24	ADDR[31:24]									
0x14	PCKSIZE	7:0	BYTE_COUNT[7:0]									
		15:8	MULTI_PACKET_SIZE[1:0]	BYTE_COUNT[13:8]								
		23:16	MULTI_PACKET_SIZE[9:2]									
		31:24	AUTO_ZLP	SIZE[2:0]			MULTI_PACKET_SIZE[13:10]					
0x18	...	Reserved										
0x19	...	Reserved										
0x1A	STATUS_BK	7:0								ERRORFLOW	CRCERR	
0x1B	...	Reserved										
0x1D	...	Reserved										
0x1E	STATUS_PIPE	7:0	ERCNT[2:0]		CRC16ER	TOUTER	PIDER	DAPIDER	DTGLER			
		15:8										



### 40.15.1 Address of the Data Buffer

**Name:** ADDR  
**Offset:** 0x00 + n\*0x10 [n=0..1]  
**Reset:** 0xxxxxxx  
**Property:** -

Bit	31	30	29	28	27	26	25	24
	ADDR[31:24]							
Access	R/W	R/W	R/W	R/W	R/W	R/W	R/W	R/W
Reset	0	0	0	0	0	0	0	0
Bit	23	22	21	20	19	18	17	16
	ADDR[23:16]							
Access	R/W	R/W	R/W	R/W	R/W	R/W	R/W	R/W
Reset	0	0	0	0	0	0	0	0
Bit	15	14	13	12	11	10	9	8
	ADDR[15:8]							
Access	R/W	R/W	R/W	R/W	R/W	R/W	R/W	R/W
Reset	0	0	0	0	0	0	0	0
Bit	7	6	5	4	3	2	1	0
	ADDR[7:0]							
Access	R/W	R/W	R/W	R/W	R/W	R/W	R/W	R/W
Reset	0	0	0	0	0	0	0	x

#### Bits 31:0 – ADDR[31:0] Data Pointer Address Value

These bits define the data pointer address as an absolute double word address in RAM. The two least significant bits must be zero to ensure the descriptor is 32-bit aligned.

## 40.15.2 Packet Size

**Name:** PCKSIZE  
**Offset:** 0x04 + n\*0x10 [n=0..1]  
**Reset:** 0xFFFFFFFF  
**Property:** -

Bit	31	30	29	28	27	26	25	24
	AUTO_ZLP		SIZE[2:0]			MULTI_PACKET_SIZE[13:10]		
Access	R/W	R/W	R/W	R/W	R/W	R/W	R/W	R/W
Reset	x	0	0	x	0	0	0	0
Bit	23	22	21	20	19	18	17	16
	MULTI_PACKET_SIZE[9:2]							
Access	R/W	R/W	R/W	R/W	R/W	R/W	R/W	R/W
Reset	0	0	0	0	0	0	0	0
Bit	15	14	13	12	11	10	9	8
	MULTI_PACKET_SIZE[1:0]		BYTE_COUNT[13:8]					
Access	R/W	R/W	R/W	R/W	R/W	R/W	R/W	R/W
Reset	0	x	0	0	0	0	0	0
Bit	7	6	5	4	3	2	1	0
	BYTE_COUNT[7:0]							
Access	R/W	R/W	R/W	R/W	R/W	R/W	R/W	R/W
Reset	0	0	0	0	0	0	0	x

### Bit 31 – AUTO\_ZLP Automatic Zero Length Packet

This bit defines the automatic Zero Length Packet mode of the pipe. When enabled, the USB module will manage the ZLP handshake by hardware. This bit is for OUT pipes only. When disabled the handshake must be managed by firmware.

Value	Description
0	Automatic Zero Length Packet is disabled.
1	Automatic Zero Length Packet is enabled.

### Bits 30:28 – SIZE[2:0] Pipe size

These bits contains the size of the pipe. These bits are cleared upon sending a USB reset.

SIZE[2:0]	Description
0x0	8 Byte
0x1	16 Byte
0x2	32 Byte
0x3	64 Byte
0x4	128 Byte <sup>(1)</sup>
0x5	256 Byte <sup>(1)</sup>
0x6	512 Byte <sup>(1)</sup>
0x7	1023 Byte <sup>(1)</sup>

**Note:**

- For Isochronous pipe only.

### Bits 27:14 – MULTI\_PACKET\_SIZE[13:0] Multi Packet IN or OUT size

These bits define the 14-bit value that is used for multi-packet transfers.

For IN pipes, MULTI\_PACKET\_SIZE holds the total number of bytes sent. MULTI\_PACKET\_SIZE must be written to zero when setting up a new transfer.  
For OUT pipes, MULTI\_PACKET\_SIZE holds the total data size for the complete transfer. This value must be a multiple of the maximum packet size.

**Bits 13:0 – BYTE\_COUNT[13:0]** Byte Count

These bits define the 14-bit value that contains number of bytes sent in the last OUT or SETUP transaction for an OUT pipe, or of the number of bytes to be received in the next IN transaction for an input pipe.

### 40.15.3 Extended Register

**Name:** EXTREG  
**Offset:** 0x08  
**Reset:** 0xFFFFFFFF  
**Property:** -

Bit	15	14	13	12	11	10	9	8
	VARIABLE[10:4]							
Access		R/W	R/W	R/W	R/W	R/W	R/W	R/W
Reset		0	0	0	0	0	0	0
Bit	7	6	5	4	3	2	1	0
	VARIABLE[3:0]				SUBPID[3:0]			
Access	R/W	R/W	R/W	R/W	R/W	R/W	R/W	R/W
Reset	0	0	0	x	0	0	0	x

#### Bits 14:4 – VARIABLE[10:0] Variable field send with extended token

These bits define the VARIABLE field sent with extended token. See “Section 2.1.1 Protocol Extension Token in the reference document ENGINEERING CHANGE NOTICE, USB 2.0 Link Power Management Addendum.”

To support the USB2.0 Link Power Management addition the VARIABLE field should be set as described below.

VARIABLE	Description
VARIABLE[3:0]	bLinkState <sup>(1)</sup>
VARIABLE[7:4]	BESL (See LPM ECN) <sup>(2)</sup>
VARIABLE[8]	bRemoteWake <sup>(1)</sup>
VARIABLE[10:9]	Reserved

#### Notes:

- For a definition of LPM Token bRemoteWake and bLinkState fields, refer to "Table 2-3 in the reference document ENGINEERING CHANGE NOTICE, USB 2.0 Link Power Management Addendum".
- For a definition of LPM Token BESL field, refer to "Table 2-3 in the reference document ENGINEERING CHANGE NOTICE, USB 2.0 Link Power Management Addendum" and "Table X-X1 in Errata for ECN USB 2.0 Link Power Management.

#### Bits 3:0 – SUBPID[3:0] SUBPID field send with extended token

These bits define the SUBPID field sent with extended token. See “Section 2.1.1 Protocol Extension Token in the reference document ENGINEERING CHANGE NOTICE, USB 2.0 Link Power Management Addendum”.

To support the USB2.0 Link Power Management addition the SUBPID field should be set as described in “Table 2.2 SubPID Types in the reference document ENGINEERING CHANGE NOTICE, USB 2.0 Link Power Management Addendum”.

#### 40.15.4 Host Status Bank

**Name:** STATUS\_BK  
**Offset:** 0x0A + n\*0x10 [n=0..1]  
**Reset:** 0xFFFFFFFF  
**Property:** -

Bit	7	6	5	4	3	2	1	0
							ERRORFLOW	CRCERR
Access							R/W	R/W
Reset							x	x

##### Bit 1 – ERRORFLOW Error Flow Status

This bit defines the Error Flow Status.

This bit is set when a Error Flow has been detected during transfer from/towards this bank.

For IN transfer, a NAK handshake has been received. For OUT transfer, a NAK handshake has been received. For Isochronous IN transfer, an overrun condition has occurred. For Isochronous OUT transfer, an underflow condition has occurred.

Value	Description
0	No Error Flow detected.
1	A Error Flow has been detected.

##### Bit 0 – CRCERR CRC Error

This bit defines the CRC Error Status.

This bit is set when a CRC error has been detected in an isochronous IN endpoint bank.

Value	Description
0	No CRC Error.
1	CRC Error detected.

### 40.15.5 Host Control Pipe

**Name:** CTRL\_PIPE  
**Offset:** 0x0C  
**Reset:** 0xFFFF  
**Property:** PAC Write-Protection, Write-Synchronized, Read-Synchronized

Bit	15	14	13	12	11	10	9	8
	PERMAX[3:0]				PEPNUM[3:0]			
Access	R/W	R/W	R/W	R/W	R/W	R/W	R/W	R/W
Reset	0	0	0	x	0	0	0	x
Bit	7	6	5	4	3	2	1	0
		PDADDR[6:0]						
Access		R/W	R/W	R/W	R/W	R/W	R/W	R/W
Reset		0	0	0	0	0	0	x

**Bits 15:12 – PERMAX[3:0]** Pipe Error Max Number

These bits define the maximum number of error for this Pipe before freezing the pipe automatically.

**Bits 11:8 – PEPNUM[3:0]** Pipe EndPoint Number

These bits define the number of endpoint for this Pipe.

**Bits 6:0 – PDADDR[6:0]** Pipe Device Address

These bits define the Device Address for this pipe.

## 40.15.6 Host Status Pipe

**Name:** STATUS\_PIPE  
**Offset:** 0x0E + n\*0x10 [n=0..1]  
**Reset:** 0xFFFFFFFF  
**Property:** PAC Write-Protection, Write-Synchronized, Read-Synchronized

Bit	15	14	13	12	11	10	9	8
Access								
Reset								
Bit	7	6	5	4	3	2	1	0
Access	R/W	R/W	R/W	R/W	R/W	R/W	R/W	R/W
Reset	0	0	x	x	x	x	x	x

**Bits 7:5 – ERCNT[2:0]** Pipe Error Counter  
 These bits define the number of errors detected on the pipe.

**Bit 4 – CRC16ER** CRC16 ERROR  
 This bit defines the CRC16 Error Status.  
 This bit is set when a CRC 16 error has been detected during a IN transactions.

Value	Description
0	No CRC 16 Error detected.
1	A CRC 16 error has been detected.

**Bit 3 – TOUTER** TIME OUT ERROR  
 This bit defines the Time Out Error Status.  
 This bit is set when a Time Out error has been detected during a USB transaction.

Value	Description
0	No Time Out Error detected.
1	A Time Out error has been detected.

**Bit 2 – PIDER** PID ERROR  
 This bit defines the PID Error Status.  
 This bit is set when a PID error has been detected during a USB transaction.

Value	Description
0	No PID Error detected.
1	A PID error has been detected.

**Bit 1 – DAPIDER** Data PID ERROR  
 This bit defines the PID Error Status.  
 This bit is set when a Data PID error has been detected during a USB transaction.

Value	Description
0	No Data PID Error detected.
1	A Data PID error has been detected.

**Bit 0 – DTGLER** Data Toggle Error  
 This bit defines the Data Toggle Error Status.  
 This bit is set when a Data Toggle Error has been detected.

Value	Description
0	No Data Toggle Error.
1	Data Toggle Error detected.

## 41. Ethernet MAC (GMAC)

The description and registers of this peripheral are using the 'GMAC' designation although the device does not support Gigabit Ethernet functionality.

### 41.1 Description

The GMAC module implements a 10/100 Mbps Ethernet MAC, compatible with the IEEE 802.3 standard. The GMAC can operate in either half or full duplex mode at all supported speeds.

### 41.2 Features

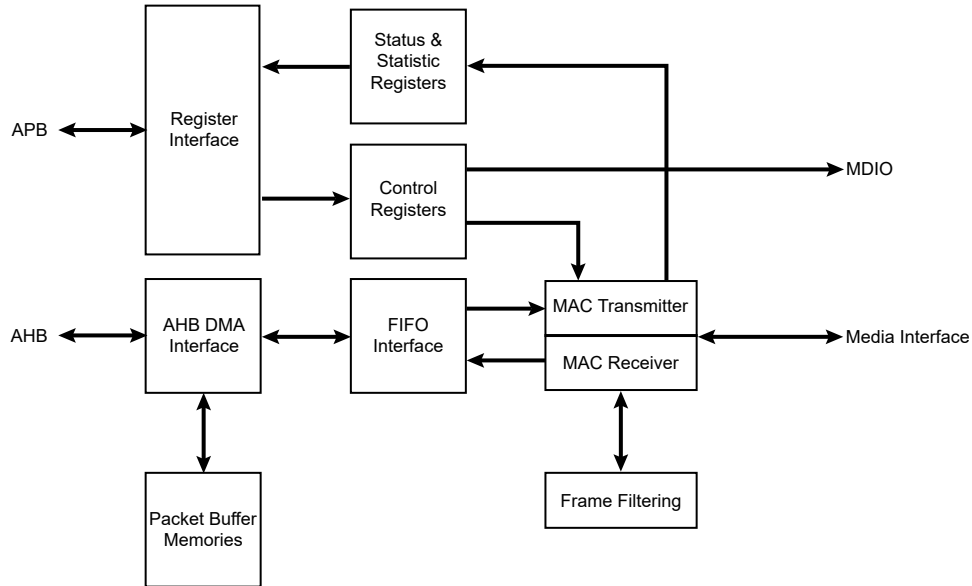
The following are key features of the GMAC:

- Compatible with IEEE Standard 802.3
- 10/100 Mbps operation
- Full and half duplex operation at all supported speeds of operation
- Statistics Counter Registers for RMON/MIB
- MII/RMII interface to the physical layer
- Integrated physical coding
- Direct memory access (DMA) interface to external memory
- Programmable burst length and endianism for DMA
- Interrupt generation to signal receive and transmit completion, errors or other events
- Automatic pad and cyclic redundancy check (CRC) generation on transmitted frames
- Automatic discard of frames received with errors
- Receive and transmit IP, TCP, and UDP checksum offload. Both IPv4 and IPv6 packet types supported
- Address checking logic for four specific 48-bit addresses, four type IDs, promiscuous mode, hash matching of unicast and multicast destination addresses, and Wake-on-LAN
- Management Data Input/Output (MDIO) interface for physical layer management
- Support for jumbo frames up to 10240 Bytes
- Full duplex flow control with recognition of incoming pause frames and hardware generation of transmitted pause frames
- Half duplex flow control by forcing collisions on incoming frames
- Support for 802.1Q VLAN tagging with recognition of incoming VLAN and priority tagged frames
- Programmable Inter Packet Gap (IPG) Stretch
- Recognition of IEEE 1588 PTP frames
- IEEE 1588 time stamp unit (TSU) and TSU event generation
- Support for 802.1AS timing and synchronization
- Supports 802.1Qav traffic shaping on two highest priority queues
- Support for 802.3az Energy Efficient Ethernet



### 41.3 Block Diagram

Figure 41-1. Block Diagram



### 41.4 Signal Description

The GMAC includes the following signal interfaces:

- MII, RMI to an external PHY
- MDIO interface for external PHY management
- Client APB interface for accessing GMAC registers
- Host AHB interface for memory access
- Internal GTSUCOMP signal for TSU timer count value comparison

Table 41-1. GMAC Connections in Different Modes

Signal Name	Function	MII	RMII
GTXCK	Transmit Clock or Reference Clock	TXCK	REFCK
GTXEN	Transmit Enable	TXEN	TXEN
GTX[3..0]	Transmit Data	TXD[3:0]	TXD[1:0]
GTXER	Transmit Coding Error	TXER	Not Used
GRXCK	Receive Clock	RXCK	Not Used
GRXDV	Receive Data Valid	RXDV	CRSDV
GRX[3..0]	Receive Data	RXD[3:0]	RXD[1:0]
GRXER	Receive Error	RXER	RXER
GCRS	Carrier Sense and Data Valid	CRS	Not Used
GCOL	Collision Detect	COL	Not Used
GMDC	Management Data Clock	MDC	MDC
GMDIO	Management Data Input/Output	MDIO	MDIO



I/Os for GMAC peripheral are grouped into IO sets. For these peripherals, it is mandatory to use I/Os that belong to the same I/O set. The timings are not guaranteed when I/Os from different I/O sets are mixed. Refer to the [Pinout and Packaging](#) chapter to get IOSET definitions.

## 41.5 Peripheral Dependencies

<b>Peripheral Name</b>	GMAC - Ethernet MAC
<b>Base Address</b>	0x4200_0800 (Peripheral Bus C)
<b>NVIC IRQ Index:Source</b>	84 : GMAC, WOL
<b>MCLK APB Clock (1)</b>	CLK_GMAC_AHB, Enabled, AHBMASK.GMAC CLK_GMAC_APB, Disabled, APBCMASK.GMAC
<b>GCLK Peripheral Channel Index:Clock Name</b>	n/a
<b>PAC Peripheral Identifier (PAC.WRCTRL)</b>	Not supported by PAC
<b>EVSYS Users (EVSYS.USERm)</b>	n/a
<b>EVSYS Generators (EVSYS.CHANNELn)</b>	114 : Timestamp Compare (GMAC_TSU_CMP)
<b>Note:</b>	
	1. Clock Name, Default State, Mask Field.

### 41.5.1 Power Management

The GMAC continues to operate in Idle mode and Standby mode if REF\_CLK or GRXCK is running.

All GMAC interrupts can be used to wake up the device from Idle mode.

In Standby mode, only the Wake On LAN (WOL) interrupt can wake up the CPU, and the corresponding ISR flags will not be set.

### 41.5.2 Clocks

The GMAC peripheral relies on a system clock from the [Main Clock Controller \(MCLK\)](#) for register access and GMAC MCK.

In MII mode, the actual Transmit or Reference Clock (GTXCK) and Receive Clock (GRXCK) are external signals.

In RMII mode, the actual Reference Clock (REF\_CLK) is an external signal.

The respective pins are configured in the [PORT](#) peripheral.

## 41.6 Functional Description

### 41.6.1 Media Access Controller

The Transmit Block of the Media Access Controller (MAC) takes data from FIFO, adds preamble, checks and adds padding and frame check sequence (FCS). Both half duplex and full duplex Ethernet modes of operation are supported.

When operating in half duplex mode, the MAC Transmit Block generates data according to the Carrier Sense Multiple Access with Collision Detect (CSMA/CD) protocol. The start of transmission is deferred if Carrier Sense (CRS) is active. If Collision (COL) is detected during transmission, a jam sequence is asserted and the transmission is retried after a random back off. The CRS and COL signals have no effect in full duplex mode.

The Receive Block of the MAC checks for valid preamble, FCS, alignment, length, and presents received frames to the MAC address checking block and FIFO. Software can configure the GMAC to receive jumbo frames of up to 10240 Bytes. It can optionally strip CRC (Cyclic Redundancy Check) from the received frame before transferring it to FIFO.

The Address Checker recognizes four specific 48-bit addresses, can recognize four different types of ID values, and contains a 64-bit Hash register for matching multicast and unicast addresses as required. It can recognize the broadcast address *all-1*' (0xFFFFFFFF) and copy all frames. The MAC can also reject all frames that are not VLAN tagged, and recognize Wake on LAN (WON) events.

The MAC Receive Block supports offloading of IP, TCP, and UDP checksum calculations (both IPv4 and IPv6 packet types supported), and can automatically discard bad checksum frames.

#### 41.6.2 IEEE 1588 Time Stamp Unit

The IEEE 1588 time stamp unit (TSU) is implemented as a 94-bit timer.

- The 48 upper bits [93:46] of the timer count seconds and are accessible in the GMAC 1588 Timer Seconds High Register (TSH) and GMAC 1588 Timer Seconds Low Register (TSL).
- The 30 lower bits [45:16] of the timer count nanoseconds and are accessible in the GMAC 1588 Timer Nanoseconds Register (TN).
- The lowest 16 bits [15:0] of the timer count sub-nanoseconds.

The 46 lower bits roll over when they have counted to 1s. The timer increments by a programmable period (to approximately 15.2femtosecond resolution) with each MCK period and can also be adjusted in 1ns resolution (incremented or decremented) through APB register accesses.

#### 41.6.3 AHB Direct Memory Access Interface

The GMAC DMA controller is connected to the MAC FIFO interface and provides a scatter-gather type capability for packet data storage.

The DMA implements packet buffering where dual-port memories are used to buffer multiple frames.

##### 41.6.3.1 Packet Buffer DMA

- Easier to guarantee maximum line rate due to the ability to store multiple frames in the packet buffer, where the number of frames is limited by the amount of packet buffer memory and Ethernet frame size
- Full store and forward, or partial store and forward programmable options (partial store will cater for shorter latency requirements)
- Support for Transmit TCP/IP checksum offload
- Support for priority queuing
- When a collision on the line occurs during transmission, the packet will be automatically replayed directly from the packet buffer memory rather than having to re-fetch through the AHB (full store and forward ONLY)
- Received erroneous packets are automatically dropped before any of the packet is presented to the AHB (full store and forward ONLY), thus reducing AHB activity
- Supports manual RX packet flush capabilities
- Optional RX packet flush when there is lack of AHB resource

##### 41.6.3.2 Partial Store and Forward Using Packet Buffer DMA

The DMA uses SRAM-based packet buffers, and can be programmed into a low latency mode, known as Partial Store and Forward. This mode allows for a reduced latency as the full packet is not buffered before forwarding.

**Note:** This option is only available when the device is configured for full duplex operation.

This feature is enabled via the programmable TX and RX Partial Store and Forward registers (TPSF and RPSF). When the transmit Partial Store and Forward mode is activated, the transmitter will only begin to forward the packet to the MAC when there is enough packet data stored in the packet buffer. Likewise, when the receive Partial Store and Forward mode is activated, the receiver will only begin to forward the packet to the AHB when enough packet data is stored in the packet buffer. The

amount of packet data required to activate the forwarding process is programmable via watermark registers. These registers are located at the same address as the partial store and forward enable bits.

**Note:** The minimum operational value for the TX partial store and forward watermark is 20. There is no operational limit for the RX partial store and forward watermark.

Enabling Partial Store and Forward is a useful means to reduce latency, but there are performance implications. The GMAC DMA uses separate transmit and receive lists of buffer descriptors, with each descriptor describing a buffer area in memory. This allows Ethernet packets to be broken up and scattered around the AHB memory space.

### 41.6.3.3 Receive AHB Buffers

Received frames, optionally including FCS, are written to receive AHB buffers stored in memory. The receive buffer depth is programmable in the range of 64 Bytes to 16 KBytes through the DMA Configuration register (DCFGR), with the default being 128 Bytes.

The start location for each receive AHB buffer is stored in memory in a list of receive buffer descriptors at an address location pointed to by the receive buffer queue pointer. The base address for the receive buffer queue pointer is configured in software using the Receive Buffer Queue Base Address register (RBQB).

Each list entry consists of two words. The first is the address of the receive AHB buffer and the second the receive status.

If the length of a receive frame exceeds the AHB buffer length, the status word for the used buffer is written with zeroes except for the “Start of Frame” bit, which is always set for the first buffer in a frame.

Bit zero of the address field is written to 1 to show that the buffer has been used. The receive buffer manager then reads the location of the next receive AHB buffer and fills that with the next part of the received frame data. AHB buffers are filled until the frame is complete and the final buffer descriptor status word contains the complete frame status. See the following table for details of the receive buffer descriptor list.

**Table 41-2.** Receive Buffer Descriptor Entry

Bit	Function
Word 0	
31:2	Address of beginning of buffer
1	Wrap—marks last descriptor in receive buffer descriptor list.
0	Ownership—needs to be zero for the GMAC to write data to the receive buffer. The GMAC sets this to one once it has successfully written a frame to memory. Software has to clear this bit before the buffer can be used again.
Word 1	
31	Global all ones broadcast address detected
30	Multicast hash match
29	Unicast hash match
28	–
27	Specific Address Register match found, bit 25 and bit 26 indicate which Specific Address Register causes the match.
26:25	Specific Address Register match. Encoded as follows: 00: Specific Address Register 1 match 01: Specific Address Register 2 match 10: Specific Address Register 3 match 11: Specific Address Register 4 match If more than one specific address is matched only one is indicated with priority 4 down to 1.

.....continued

Bit	Function
24	<p>This bit has a different meaning depending on whether RX checksum offloading is enabled.</p> <p>With RX checksum offloading disabled: (bit 24 clear in Network Configuration Register)</p> <p>Type ID register match found, bit 22 and bit 23 indicate which type ID register causes the match.</p> <p>With RX checksum offloading enabled: (bit 24 set in Network Configuration Register)</p> <p>0: The frame was not SNAP encoded and/or had a VLAN tag with the Canonical Format Indicator (CFI) bit set.</p> <p>1: The frame was SNAP encoded and had either no VLAN tag or a VLAN tag with the CFI bit not set.</p>
23:22	<p>This bit has a different meaning depending on whether RX checksum offloading is enabled.</p> <p>With RX checksum offloading disabled: (bit 24 clear in Network Configuration Register)</p> <p>Type ID register match. Encoded as follows:</p> <p>00: Type ID register 1 match</p> <p>01: Type ID register 2 match</p> <p>10: Type ID register 3 match</p> <p>11: Type ID register 4 match</p> <p>If more than one Type ID is matched only one is indicated with priority 4 down to 1.</p> <p>With RX checksum offloading enabled: (bit 24 set in Network Configuration Register)</p> <p>00: Neither the IP header checksum nor the TCP/UDP checksum was checked.</p> <p>01: The IP header checksum was checked and was correct. Neither the TCP nor UDP checksum was checked.</p> <p>10: Both the IP header and TCP checksum were checked and were correct.</p> <p>11: Both the IP header and UDP checksum were checked and were correct.</p>
21	VLAN tag detected—type ID of 0x8100. For packets incorporating the stacked VLAN processing feature, this bit will be set if the second VLAN tag has a type ID of 0x8100
20	Priority tag detected—type ID of 0x8100 and null VLAN identifier. For packets incorporating the stacked VLAN processing feature, this bit will be set if the second VLAN tag has a type ID of 0x8100 and a null VLAN identifier.
19:17	VLAN priority—only valid if bit 21 is set.
16	Canonical format indicator (CFI) bit (only valid if bit 21 is set).
15	End of frame—when set the buffer contains the end of a frame. If end of frame is not set, then the only valid status bit is start of frame (bit 14).
14	Start of frame—when set the buffer contains the start of a frame. If both bits 15 and 14 are set, the buffer contains a whole frame.
13	<p>This bit has a different meaning depending on whether jumbo frames and ignore FCS modes are enabled. If neither mode is enabled this bit will be zero.</p> <p>With jumbo frame mode enabled: (bit 3 set in Network Configuration Register) Additional bit for length of frame (bit[13]), that is concatenated with bits[12:0]</p> <p>With ignore FCS mode enabled and jumbo frames disabled: (bit 26 set in Network Configuration Register and bit 3 clear in Network Configuration Register) This indicates per frame FCS status as follows:</p> <p>0: Frame had good FCS</p> <p>1: Frame had bad FCS, but was copied to memory as ignore FCS enabled.</p>
12:0	<p>These bits represent the length of the received frame which may or may not include FCS depending on whether FCS discard mode is enabled.</p> <p>With FCS discard mode disabled: (bit 17 clear in Network Configuration Register)</p> <p>Least significant 12 bits for length of frame including FCS. If jumbo frames are enabled, these 12 bits are concatenated with bit[13] of the descriptor above.</p> <p>With FCS discard mode enabled: (bit 17 set in Network Configuration Register)</p> <p>Least significant 12 bits for length of frame excluding FCS. If jumbo frames are enabled, these 12 bits are concatenated with bit[13] of the descriptor above.</p>

Each receive AHB buffer start location is a word address. The start of the first AHB buffer in a frame can be offset by up to three Bytes, depending on the value written to bits 14 and 15 of the Network Configuration register (NCFGR). If the start location of the AHB buffer is offset, the available length of the first AHB buffer is reduced by the corresponding number of Bytes.

To receive frames, the AHB buffer descriptors must be initialized by writing an appropriate address to bits 31:2 in the first word of each list entry. Bit 0 must be written with zero. Bit 1 is the wrap bit and indicates the last entry in the buffer descriptor list.

The start location of the receive buffer descriptor list must be written with the receive buffer queue base address before reception is enabled (receive enable in the Network Control register NCR). Once reception is enabled, any writes to the Receive Buffer Queue Base Address register (RBQB) are ignored. When read, it will return the current pointer position in the descriptor list, though this is only valid and stable when receive is disabled.

If the filter block indicates that a frame should be copied to memory, the receive data DMA operation starts writing data into the receive buffer. If an error occurs, the buffer is recovered.

An internal counter within the GMAC represents the receive buffer queue pointer and it is not visible through the CPU interface. The receive buffer queue pointer increments by two words after each buffer has been used. It re-initializes to the receive buffer queue base address if any descriptor has its wrap bit set.

As receive AHB buffers are used, the receive AHB buffer manager sets bit zero of the first word of the descriptor to logic one indicating the AHB buffer has been used.

Software should search through the “used” bits in the AHB buffer descriptors to find out how many frames have been received, checking the start of frame and end of frame bits.

When the DMA is configured in the packet buffer Partial Store And Forward mode, received frames are written out to the AHB buffers as soon as enough frame data exists in the packet buffer. For both cases, this may mean several full AHB buffers are used before some error conditions can be detected. If a receive error is detected the receive buffer currently being written will be recovered. Previous buffers will not be recovered. As an example, when receiving frames with cyclic redundancy check (CRC) errors or excessive length, it is possible that a frame fragment might be stored in a sequence of AHB receive buffers. Software can detect this by looking for start of frame bit set in a buffer following a buffer with no end of frame bit set.

To function properly, a 10/100 Ethernet system should have no excessive length frames or frames greater than 128 Bytes with CRC errors. Collision fragments will be less than 128 Bytes long, therefore it will be a rare occurrence to find a frame fragment in a receive AHB buffer, when using the default value of 128 Bytes for the receive buffers size.

When in packet buffer full store and forward mode, only good received frames are written out of the DMA, so no fragments will exist in the AHB buffers due to MAC receiver errors. There is still the possibility of fragments due to DMA errors, for example used bit read on the second buffer of a multi-buffer frame.

If bit zero of the receive buffer descriptor is already set when the receive buffer manager reads the location of the receive AHB buffer, the buffer has been already used and cannot be used again until software has processed the frame and cleared bit zero. In this case, the “buffer not available” bit in the receive status register is set and an interrupt triggered. The receive resource error statistics register is also incremented.

When the DMA is configured in the packet buffer full store and forward mode, the user can optionally select whether received frames should be automatically discarded when no AHB buffer resource is available. This feature is selected via the DMA Discard Receive Packets bit in the DMA Configuration register (DCFGR.DDRP). By default, the received frames are not automatically discarded. If this feature is off, then received packets will remain to be stored in the SRAM-based packet buffer until AHB buffer resource next becomes available. This may lead to an eventual packet buffer overflow if packets continue to be received when bit zero (used bit) of the receive buffer descriptor remains set.

**Note:** After a used bit has been read, the receive buffer manager will re-read the location of the receive buffer descriptor every time a new packet is received. When the DMA is not configured in the packet buffer full store and forward mode and a used bit is read, the frame currently being received will be automatically discarded.

When the DMA is configured in the packet buffer full store and forward mode, a receive overrun condition occurs when the receive SRAM-based packet buffer is full, or because HRESP was not OK. In all other modes, a receive overrun condition occurs when either the AHB bus was not granted quickly enough, or because HRESP was not OK, or because a new frame has been detected by the receive block, but the status update or write back for the previous frame has not yet finished. For a receive overrun condition, the receive overrun interrupt is asserted and the buffer currently being written is recovered. The next frame that is received whose address is recognized reuses the buffer.

In any packet buffer mode, writing a '1' to the Flush Next Package bit in the NCR register (NCR.FNP) will force a packet from the external SRAM-based receive packet buffer to be flushed. This feature is only acted upon when the RX DMA is not currently writing packet data out to AHB, i.e., it is in an IDLE state. If the RX DMA is active, NCR.FNP=1 is ignored.

#### 41.6.3.4 Transmit AHB Buffers

Frames to transmit are stored in one or more transmit AHB buffers. Transmit frames can be between 1 and 16384 Bytes long, so it is possible to transmit frames longer than the maximum length specified in the IEEE 802.3 standard. It should be noted that zero length AHB buffers are allowed and that the maximum number of buffers permitted for each transmit frame is 128.

The start location for each transmit AHB buffer is stored in memory in a list of transmit buffer descriptors at a location pointed to by the transmit buffer queue pointer. The base address for this queue pointer is set in software using the Transmit Buffer Queue Base Address register. Each list entry consists of two words. The first is the Byte address of the transmit buffer and the second containing the transmit control and status. For the packet buffer DMA, the start location for each AHB buffer is a Byte address, the bottom bits of the address being used to offset the start of the data from the data-word boundary (i.e., bits 2,1 and 0 are used to offset the address for 64-bit data paths).

Frames can be transmitted with or without automatic Cyclic Redundancy Checksum (CRC) generation. If CRC is automatically generated, pad will also be automatically generated to take frames to a minimum length of 64 Bytes. When CRC is not automatically generated (as defined in word 1 of the transmit buffer descriptor), the frame is assumed to be at least 64 Bytes long and pad is not generated.

An entry in the transmit buffer descriptor list is described in this table:

**Table 41-3.** Transmit Buffer Descriptor Entry

Bit	Function
Word 0	
31:0	Byte address of buffer
Word 1	
31	Used—must be zero for the GMAC to read data to the transmit buffer. The GMAC sets this to one for the first buffer of a frame once it has been successfully transmitted. Software must clear this bit before the buffer can be used again.
30	Wrap—marks last descriptor in transmit buffer descriptor list. This can be set for any buffer within the frame.
29	Retry limit exceeded, transmit error detected
28	Reserved.
27	Transmit frame corruption due to AHB error—set if an error occurs while midway through reading transmit frame from the AHB, including HRESP errors and buffers exhausted mid frame (if the buffers run out during transmission of a frame then transmission stops, FCS shall be bad and GTXER asserted). Also set if single frame is too large for configured packet buffer memory size.
26	Late collision, transmit error detected.

.....continued

Bit	Function
25:23	Reserved
22:20	Transmit IP/TCP/UDP checksum generation offload errors: 000: No Error. 001: The Packet was identified as a VLAN type, but the header was not fully complete, or had an error in it. 010: The Packet was identified as a SNAP type, but the header was not fully complete, or had an error in it. 011: The Packet was not of an IP type, or the IP packet was invalidly short, or the IP was not of type IPv4/IPv6. 100: The Packet was not identified as VLAN, SNAP or IP. 101: Non supported packet fragmentation occurred. For IPv4 packets, the IP checksum was generated and inserted. 110: Packet type detected was not TCP or UDP. TCP/UDP checksum was therefore not generated. For IPv4 packets, the IP checksum was generated and inserted. 111: A premature end of packet was detected and the TCP/UDP checksum could not be generated.
19:17	Reserved
16	No CRC to be appended by MAC. When set, this implies that the data in the buffers already contains a valid CRC, hence no CRC or padding is to be appended to the current frame by the MAC. This control bit must be set for the first buffer in a frame and will be ignored for the subsequent buffers of a frame. Note that this bit must be clear when using the transmit IP/TCP/UDP checksum generation offload, otherwise checksum generation and substitution will not occur.
15	Last buffer, when set this bit will indicate the last buffer in the current frame has been reached.
14	Reserved
13:0	Length of buffer

To transmit frames, the buffer descriptors must be initialized by writing an appropriate Byte address to bits [31:0] of the first word of each descriptor list entry.

The second word of the transmit buffer descriptor is initialized with control information that indicates the length of the frame, whether or not the MAC is to append CRC and whether the buffer is the last buffer in the frame.

After transmission the status bits are written back to the second word of the first buffer along with the used bit. Bit 31 is the used bit which must be zero when the control word is read if transmission is to take place. It is written to '1' once the frame has been transmitted. Bits[29:20] indicate various transmit error conditions. Bit 30 is the wrap bit which can be set for any buffer within a frame. If no wrap bit is encountered the queue pointer continues to increment.

The Transmit Buffer Queue Base Address register can only be updated while transmission is disabled or halted; otherwise any attempted write will be ignored. When transmission is halted the transmit buffer queue pointer will maintain its value. Therefore when transmission is restarted the next descriptor read from the queue will be from immediately after the last successfully transmitted frame. As long as transmit is disabled by writing a '0' to the Transmit Enable bit in the Network Control register (NCR.TXEN), the transmit buffer queue pointer resets to point to the address indicated by the Transmit Buffer Queue Base Address register (TBQB).

**Note:** Disabling receive does not have the same effect on the receive buffer queue pointer.

Once the transmit queue is initialized, transmit is activated by writing a '1' to the Start Transmission bit of the Network Control register (NCR.TSTART). Transmit is halted when a buffer descriptor with its used bit set is read, a transmit error occurs, or by writing to the Transmit Halt bit of the Network Control register (NCR.THALT). Transmission is suspended if a pause frame is received while the Transmit Pause Frame bit is '1' in the Network Configuration register (NCR.TXPF). Rewriting the Start bit (NCR.TSTART) while transmission is active is allowed. This is implemented by the Transmit Go variable which is readable in the Transmit Status register (TSR.TXGO). The TXGO variable is reset when:

- Transmit is disabled
- A buffer descriptor with its used bit set is read



- Bit 10, THALT, of the Network Control register is written
- There is a transmit error such as too many retries or a transmit underrun

To set TXGO, write a '1' to NCR.TSTART. Transmit halt does not take effect until any ongoing transmit finishes.

If the DMA is configured for packet buffer Partial Store and Forward mode and a collision occurs during transmission of a multi-buffer frame, transmission will automatically restart from the first buffer of the frame. For packet buffer mode, the entire contents of the frame are read into the transmit packet buffer memory, so the retry attempt will be replayed directly from the packet buffer memory rather than having to re-fetch through the AHB.

If a used bit is read midway through transmission of a multi-buffer frame, this is treated as a transmit error. Transmission stops, GTXER is asserted and the FCS will be bad.

If transmission stops due to a transmit error or a used bit being read, transmission restarts from the first buffer descriptor of the frame being transmitted when the transmit start bit is rewritten.

#### 41.6.3.5 DMA Bursting on the AHB

The DMA will always use SINGLE, or INCR type AHB accesses for buffer management operations. When performing data transfers, the AHB burst length is selected by the Fixed Burst Length for DMA Data Operations bit field in the DMA Configuration register (DCFGR.FBLDO) so that either SINGLE or fixed length incrementing bursts (INCR4, INCR8 or INCR16) are used where possible:

When there is enough space and enough data to be transferred, the programmed fixed length bursts will be used. If there is not enough data or space available, for example when at the beginning or the end of a buffer, SINGLE type accesses are used. Also SINGLE type accesses are used at 1024 Byte boundaries, so that the 1 KByte boundaries are not burst over as per AHB requirements.

The DMA will not terminate a fixed length burst early, unless an error condition occurs on the AHB or if receive or transmit are disabled in the Network Control register (NCR).

#### 41.6.3.6 DMA Packet Buffer

The DMA uses packet buffers for both transmit and receive paths. This mode allows multiple packets to be buffered in both transmit and receive directions. This allows the DMA to withstand far greater access latencies on the AHB and make more efficient use of the AHB bandwidth. There are two modes of operation—Full Store and Forward and Partial Store and Forward.

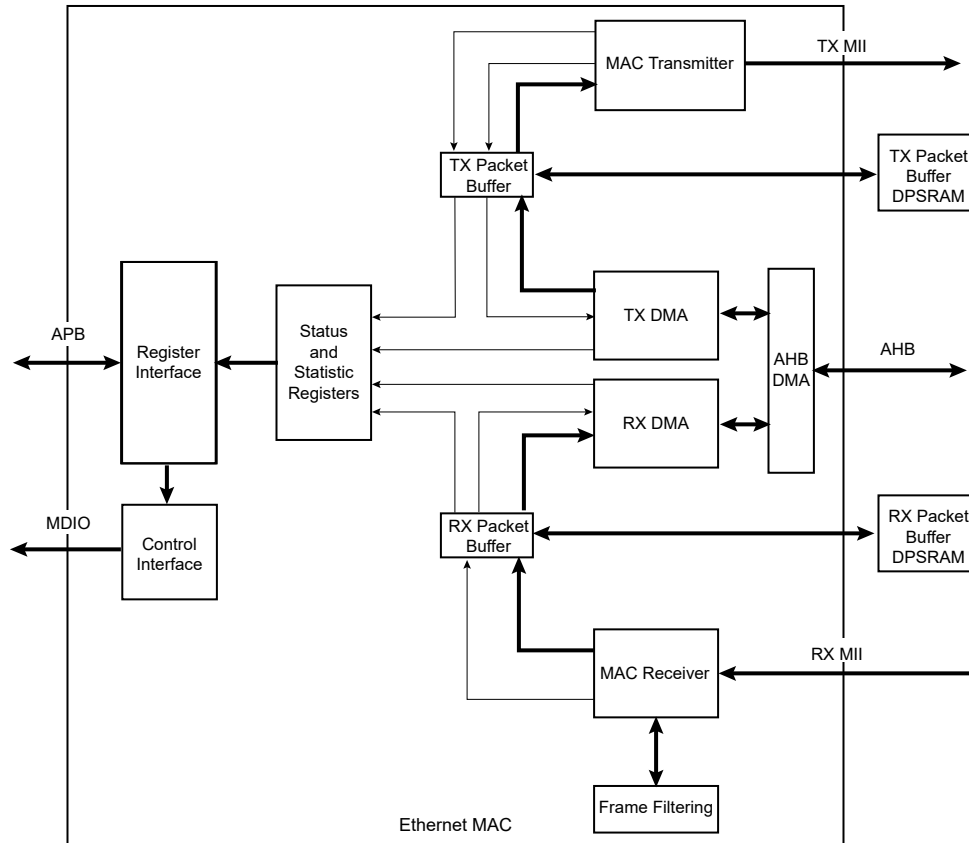
As described above, the DMA can be programmed into a low latency mode, known as Partial Store and Forward. For further details of this mode, see the related Links.

When the DMA is in full store and forward mode, full packets are buffered which provides the possibility to:

- Discard packets with error on the receive path before they are partially written out of the DMA, thus saving AHB bus bandwidth and driver processing overhead,
- Retry collided transmit frames from the buffer, thus saving AHB bus bandwidth,
- Implement transmit IP/TCP/UDP checksum generation offload.

With the packet buffers included, the structure of the GMAC data paths is shown in this image:

Figure 41-2. Data Paths with Packet Buffers Included



### 41.6.3.7 Transmit Packet Buffer

The transmitter packet buffer will continue attempting to fetch frame data from the AHB system memory until the packet buffer itself is full, at which point it will attempt to maintain its full level.

To accommodate the status and statistics associated with each frame, three words per packet (or two if the GMAC is configured in 64-bit data path mode) are reserved at the end of the packet data. If the packet is bad and requires to be dropped, the status and statistics are the only information held on that packet. Storing the status in the DPRAM is required in order to decouple the DMA interface of the buffer from the MAC interface, to update the MAC status/statistics and to generate interrupts in the order in which the packets that they represent were fetched from the AHB memory.

If any errors occur on the AHB while reading the transmit frame, the fetching of packet data from AHB memory is halted. The MAC transmitter will continue to fetch packet data, thereby emptying the packet buffer and allowing any good (non-erroneous) frames to be transmitted successfully. Once these have been fully transmitted, the status/statistics for the erroneous frame will be updated and software will be informed via an interrupt that an AHB error occurred. This way, the error is reported in the correct packet order.

The transmit packet buffer will only attempt to read more frame data from the AHB when space is available in the packet buffer memory. If space is not available it must wait until the a packet fetched by the MAC completes transmission and is subsequently removed from the packet buffer memory.

**Note:** If full store and forward mode is active and if a single frame is fetched that is too large for the packet buffer memory, the frame is flushed and the DMA halted with an error status. This is because a complete frame must be written into the packet buffer before transmission can begin, and therefore the minimum packet buffer memory size should be chosen to satisfy the maximum frame to be transmitted in the application.

In full store and forward mode, once the complete transmit frame is written into the packet buffer memory, a trigger is sent across to the MAC transmitter, which will then begin reading the frame from the packet buffer memory. Since the whole frame is present and stable in the packet buffer memory an underflow of the transmitter is not possible. The frame is kept in the packet buffer until notification is received from the MAC that the frame data has either been successfully transmitted or can no longer be retransmitted (too many retries in half duplex mode). When this notification is received the frame is flushed from memory to make room for a new frame to be fetched from AHB system memory.

In Partial Store and Forward mode, a trigger is sent across to the MAC transmitter as soon as sufficient packet data is available, which will then begin fetching the frame from the packet buffer memory. If, after this point, the MAC transmitter is able to fetch data from the packet buffer faster than the AHB DMA can fill it, an underflow of the transmitter is possible. In this case, the transmission is terminated early, and the packet buffer is completely flushed. Transmission can only be restarted by writing a '1' to the Transmit Start bit in the Network Control register (NCR.TSTART).

In half duplex mode, the frame is kept in the packet buffer until notification is received from the MAC that the frame data has either been successfully transmitted or can no longer be retransmitted (too many retries in half duplex mode). When this notification is received the frame is flushed from memory to make room for a new frame to be fetched from AHB system memory.

In full duplex mode, the frame is removed from the packet buffer on the fly.

Other than underflow, the only MAC related errors that can occur are due to collisions during half duplex transmissions. When a collision occurs the frame still exists in the packet buffer memory so can be retried directly from there. After sixteen failed transmit attempts, the frame will be flushed from the packet buffer.

#### 41.6.3.8 Receive Packet Buffer

The receive packet buffer stores frames from the MAC receiver along with their status and statistics. Frames with errors are flushed from the packet buffer memory, while good frames are pushed onto the DMA AHB interface.

The receiver packet buffer monitors the FIFO write interface from the MAC receiver and translates the FIFO pushes into packet buffer writes. At the end of the received frame the status and statistics are buffered so that the information can be used when the frame is read out. When programmed in full store and forward mode and the frame has an error, the frame data is immediately flushed from the packet buffer memory allowing subsequent frames to utilize the freed up space. The status and statistics for bad frames are still used to update the GMAC registers.

To accommodate the status and statistics associated with each frame, three words per packet (or two if configured in 64-bit datapath mode) are reserved at the end of the packet data. If the packet is bad and requires to be dropped, the status and statistics are the only information held on that packet.

The receiver packet buffer will also detect a full condition so that an overflow condition can be detected. If this occurs, subsequent packets are dropped and an RX overflow interrupt is raised.

For full store and forward, the DMA only begins packet fetches once the status and statistics for a frame are available. If the frame has a bad status due to a frame error, the status and statistics are passed on to the GMAC registers. If the frame has a good status, the information is used to read the frame from the packet buffer memory and burst onto the AHB using the DMA buffer management protocol. Once the last frame data has been transferred to the packet buffer, the status and statistics are updated to the GMAC registers.

If Partial Store and Forward mode is active, the DMA will begin fetching the packet data before the status is available. As soon as the status becomes available, the DMA will fetch this information as soon as possible before continuing to fetch the remainder of the frame. Once the last frame data has been transferred to the packet buffer, the status and statistics are updated to the GMAC registers.

#### 41.6.4 MAC Transmit Block

The MAC transmitter can operate in either half duplex or full duplex mode and transmits frames in accordance with the Ethernet IEEE 802.3 standard. In half duplex mode, the CSMA/CD protocol of the IEEE 802.3 specification is followed.

A small input buffer receives data through the FIFO interface which will extract data in 32-bit form. All subsequent processing prior to the final output is performed in bytes.

Transmit data can be output using the MII interface.

Frame assembly starts by adding preamble and the start frame delimiter. Data is taken from the transmit FIFO interface a word at a time.

If necessary, padding is added to take the frame length to 60 bytes. CRC is calculated using an order 32-bit polynomial. This is inverted and appended to the end of the frame taking the frame length to a minimum of 64 bytes. If the no CRC bit is set in the second word of the last buffer descriptor of a transmit frame, neither pad nor CRC are appended. The no CRC bit can also be set through the FIFO interface.

In full duplex mode (at all data rates), frames are transmitted immediately. Back to back frames are transmitted at least 96 bit times apart to guarantee the interframe gap.

In half duplex mode, the transmitter checks carrier sense. If asserted, the transmitter waits for the signal to become inactive, and then starts transmission after the interframe gap of 96 bit times. If the collision signal is asserted during transmission, the transmitter will transmit a jam sequence of 32 bits taken from the data register and then retry transmission after the back off time has elapsed. If the collision occurs during either the preamble or Start Frame Delimiter (SFD), then these fields will be completed prior to generation of the jam sequence.

The back off time is based on an XOR of the 10 least significant bits of the data coming from the transmit FIFO interface and a 10-bit pseudo random number generator. The number of bits used depends on the number of collisions seen. After the first collision 1 bit is used, then the second 2 bits and so on up to the maximum of 10 bits. All 10 bits are used above ten collisions. An error will be indicated and no further attempts will be made if 16 consecutive attempts cause collision. This operation is compliant with the description in Clause 4.2.3.2.5 of the IEEE 802.3 standard which refers to the truncated binary exponential back off algorithm.

In 10/100 mode, both collisions and late collisions are treated identically, and back off and retry will be performed up to 16 times. This condition is reported in the transmit buffer descriptor word 1 (late collision, bit 26) and also in the Transmit Status register (late collision, bit 7). An interrupt can also be generated (if enabled) when this exception occurs, and bit 5 in the Interrupt Status register will be set.

In all modes of operation, if the transmit DMA underruns, a bad CRC is automatically appended using the same mechanism as jam insertion and the GTXER signal is asserted. For a properly configured system this should never happen and also it is impossible if configured to use the DMA with packet buffers, as the complete frame is buffered in local packet buffer memory.

By setting when bit 28 is set in the Network Configuration register, the Inter Packet Gap (IPG) may be stretched beyond 96 bits depending on the length of the previously transmitted frame and the value written to the IPG Stretch register (IPGS). The least significant 8 bits of the IPG Stretch register multiply the previous frame length (including preamble). The next significant 8 bits (+1 so as not to get a divide by zero) divide the frame length to generate the IPG. IPG stretch only works in full duplex mode and when bit 28 is set in the Network Configuration register. The IPG Stretch register cannot be used to shrink the IPG below 96 bits.

If the back pressure bit is set in the Network Control register, or if the HDFC configuration bit is set in the UR register (10M or 100M half duplex mode), the transmit block transmits 64 bits of data, which can consist of 16 nibbles of 1011 or in bit rate mode 64 1s, whenever it sees an incoming frame to force a collision. This provides a way of implementing flow control in half duplex mode.

### 41.6.5 MAC Receive Block

All processing within the MAC receive block is implemented using a 16-bit data path. The MAC receive block checks for valid preamble, FCS, alignment and length, presents received frames to the FIFO interface and stores the frame destination address for use by the address checking block.

If, during the frame reception, the frame is found to be too long, a bad frame indication is sent to the FIFO interface. The receiver logic ceases to send data to memory as soon as this condition occurs.

At end of frame reception the receive block indicates to the DMA block whether the frame is good or bad. The DMA block will recover the current receive buffer if the frame was bad.

Ethernet frames are normally stored in DMA memory complete with the FCS. Setting the FCS remove bit in the network configuration (bit 17) causes frames to be stored without their corresponding FCS. The reported frame length field is reduced by four bytes to reflect this operation.

The receive block signals to the register block to increment the alignment, CRC (FCS), short frame, long frame, jabber or receive symbol errors when any of these exception conditions occur.

If bit 26 is set in the network configuration, CRC errors will be ignored and CRC errored frames will not be discarded, though the Frame Check Sequence Errors statistic register will still be incremented. Additionally, if not enabled for jumbo frames mode, then bit[13] of the receiver descriptor word 1 will be updated to indicate the FCS validity for the particular frame. This is useful for applications such as EtherCAT whereby individual frames with FCS errors must be identified.

Received frames can be checked for length field error by setting the length field error frame discard bit of the Network Configuration register (bit-16). When this bit is set, the receiver compares a frame's measured length with the length field (bytes 13 and 14) extracted from the frame. The frame is discarded if the measured length is shorter. This checking procedure is for received frames between 64 bytes and 1518 bytes in length.

Each discarded frame is counted in the 10-bit length field error statistics register. Frames where the length field is greater than or equal to 0x0600 hex will not be checked.

### 41.6.6 Checksum Offload for IP, TCP and UDP

The GMAC can be programmed to perform IP, TCP and UDP checksum offloading in both receive and transmit directions, which is enabled by setting bit 24 in the Network Configuration register for receive and bit 11 in the DMA Configuration register for transmit.

IPv4 packets contain a 16-bit checksum field, which is the 16-bit 1's complement of the 1's complement sum of all 16-bit words in the header. TCP and UDP packets contain a 16-bit checksum field, which is the 16-bit 1's complement of the 1's complement sum of all 16-bit words in the header, the data and a conceptual IP pseudo header.

To calculate these checksums in software requires each byte of the packet to be processed. For TCP and UDP this can use a large amount of processing power. Offloading the checksum calculation to hardware can result in significant performance improvements.

For IP, TCP or UDP checksum offload to be useful, the operating system containing the protocol stack must be aware that this offload is available so that it can make use of the fact that the hardware can either generate or verify the checksum.

#### 41.6.6.1 Receiver Checksum Offload

When receive checksum offloading is enabled in the GMAC Network Configuration Register (NCFGR.RXCOEN), the IPv4 header checksum is checked as per RFC 791, where the packet meets the following criteria:

- If present, the VLAN header must be four octets long and the CFI bit must not be set.
- Encapsulation must be RFC 894 Ethernet Type Encoding or RFC 1042 SNAP Encoding.

- IPv4 packet
- IP header is of a valid length

The GMAC also checks the TCP checksum as per RFC 793, or the UDP checksum as per RFC 768, if the following criteria are met:

- IPv4 or IPv6 packet
- Good IP header checksum (if IPv4)
- No IP fragmentation
- TCP or UDP packet

When an IP, TCP or UDP frame is received, the receive buffer descriptor gives an indication if the GMAC was able to verify the checksums. There is also an indication if the frame had SNAP encapsulation. These indication bits will replace the type ID match indication bits when the receive checksum offload is enabled. For details of these indication bits refer to ["Receive Buffer Descriptor Entry"](#).

If any of the checksums are verified as incorrect by the GMAC, the packet is discarded and the appropriate statistics counter incremented.

#### 41.6.6.2 Transmitter Checksum Offload

The transmitter checksum offload is only available if the full store and forward mode is enabled. This is because the complete frame to be transmitted must be read into the packet buffer memory before the checksum can be calculated and written back into the headers at the beginning of the frame.

Transmitter checksum offload is enabled by setting bit [11] in the DMA Configuration register. When enabled, it will monitor the frame as it is written into the transmitter packet buffer memory to automatically detect the protocol of the frame. Protocol support is identical to the receiver checksum offload.

For transmit checksum generation and substitution to occur, the protocol of the frame must be recognized and the frame must be provided without the FCS field, by making sure that bit [16] of the transmit descriptor word 1 is clear. If the frame data already had the FCS field, this would be corrupted by the substitution of the new checksum fields.

If these conditions are met, the transmit checksum offload engine will calculate the IP, TCP and UDP checksums as appropriate. Once the full packet is completely written into packet buffer memory, the checksums will be valid and the relevant DPRAM locations will be updated for the new checksum fields as per standard IP/TCP and UDP packet structures.

If the transmitter checksum engine is prevented from generating the relevant checksums, bits [22:20] of the transmitter DMA writeback status will be updated to identify the reason for the error. Note that the frame will still be transmitted but without the checksum substitution, as typically the reason that the substitution did not occur was that the protocol was not recognized.

#### 41.6.7 MAC Filtering Block

The filter block determines which frames should be written to the FIFO interface and on to the DMA.

Whether a frame is passed depends on what is enabled in the Network Configuration register, the state of the external matching pins, the contents of the specific address, type and Hash registers and the frame's destination address and type field.

If bit 25 of the Network Configuration register is not set, a frame will not be copied to memory if the GMAC is transmitting in half duplex mode at the time a destination address is received.

Ethernet frames are transmitted a byte at a time, least significant bit first. The first six bytes (48 bits) of an Ethernet frame make up the destination address. The first bit of the destination address, which is the LSB of the first byte of the frame, is the group or individual bit. This is one for multicast

addresses and zero for unicast. The all ones address is the broadcast address and a special case of multicast.

The GMAC supports recognition of four specific addresses. Each specific address requires two registers, Specific Address register Bottom and Specific Address register Top. Specific Address register Bottom stores the first four bytes of the destination address and Specific Address register Top contains the last two bytes. The addresses stored can be specific, group, local or universal.

The destination address of received frames is compared against the data stored in the Specific Address registers once they have been activated. The addresses are deactivated at reset or when their corresponding Specific Address register Bottom is written. They are activated when Specific Address register Top is written. If a receive frame address matches an active address, the frame is written to the FIFO interface and on to DMA memory.

Frames may be filtered using the type ID field for matching. Four type ID registers exist in the register address space and each can be enabled for matching by writing a one to the MSB (bit 31) of the respective register. When a frame is received, the matching is implemented as an OR function of the various types of match.

The contents of each type ID register (when enabled) are compared against the length/type ID of the frame being received (e.g., bytes 13 and 14 in non-VLAN and non-SNAP encapsulated frames) and copied to memory if a match is found. The encoded type ID match bits (Word 0, Bit 22 and Bit 23) in the receive buffer descriptor status are set indicating which type ID register generated the match, if the receive checksum offload is disabled.

The reset state of the type ID registers is zero, hence each is initially disabled.

The following example illustrates the use of the address and type ID match registers for a MAC address of 21:43:65:87:A9:CB:

Preamble	55
SFD	D5
DA (Octet 0 - LSB)	21
DA (Octet 1)	43
DA (Octet 2)	65
DA (Octet 3)	87
DA (Octet 4)	A9
DA (Octet 5 - MSB)	CB
SA (LSB)	00 (see <b>Note</b> )
SA	00(see <b>Note</b> )
SA	00(see <b>Note</b> )
SA	00(see <b>Note</b> )
SA	00(see <b>Note</b> )
SA (MSB)	00(see <b>Note</b> )
Type ID (MSB)	43
Type ID (LSB)	21

**Note:** Contains the address of the transmitting device.

The previous sequence shows the beginning of an Ethernet frame. Byte order of transmission is from top to bottom, as shown. For a successful match to specific address 1, the following address matching registers must be set up:

Specific Address 1 Bottom register (SAB1) (Address 0x088) 0x87654321

Specific Address 1 Top register (SAT1) (Address 0x08C) 0x0000CBA9

For a successful match to the type ID, the following Type ID Match 1 register must be set up:

Type ID Match 1 register (TIDM1) (Address 0x0A8) 0x80004321

#### 41.6.8 Broadcast Address

Frames with the broadcast address of 0xFFFFFFFF are stored to memory only if the 'no broadcast' bit in the Network Configuration register is set to zero.

#### 41.6.9 Hash Addressing

The hash address register is 64 bits long and takes up two locations in the memory map. The least significant bits are stored in Hash Register Bottom and the most significant bits in Hash Register Top.

The unicast hash enable and the multicast hash enable bits in the Network Configuration register enable the reception of hash matched frames. The destination address is reduced to a 6-bit index into the 64-bit Hash register using the following hash function: The hash function is an XOR of every sixth bit of the destination address.

$$\text{hash\_index}[05] = \text{da}[05] \wedge \text{da}[11] \wedge \text{da}[17] \wedge \text{da}[23] \wedge \text{da}[29] \wedge \text{da}[35] \wedge \text{da}[41] \wedge \text{da}[47]$$

$$\text{hash\_index}[04] = \text{da}[04] \wedge \text{da}[10] \wedge \text{da}[16] \wedge \text{da}[22] \wedge \text{da}[28] \wedge \text{da}[34] \wedge \text{da}[40] \wedge \text{da}[46]$$

$$\text{hash\_index}[03] = \text{da}[03] \wedge \text{da}[09] \wedge \text{da}[15] \wedge \text{da}[21] \wedge \text{da}[27] \wedge \text{da}[33] \wedge \text{da}[39] \wedge \text{da}[45]$$

$$\text{hash\_index}[02] = \text{da}[02] \wedge \text{da}[08] \wedge \text{da}[14] \wedge \text{da}[20] \wedge \text{da}[26] \wedge \text{da}[32] \wedge \text{da}[38] \wedge \text{da}[44]$$

$$\text{hash\_index}[01] = \text{da}[01] \wedge \text{da}[07] \wedge \text{da}[13] \wedge \text{da}[19] \wedge \text{da}[25] \wedge \text{da}[31] \wedge \text{da}[37] \wedge \text{da}[43]$$

$$\text{hash\_index}[00] = \text{da}[00] \wedge \text{da}[06] \wedge \text{da}[12] \wedge \text{da}[18] \wedge \text{da}[24] \wedge \text{da}[30] \wedge \text{da}[36] \wedge \text{da}[42]$$

da[0] represents the least significant bit of the first byte received, that is, the multicast/unicast indicator, and da[47] represents the most significant bit of the last byte received.

If the hash index points to a bit that is set in the Hash register then the frame will be matched according to whether the frame is multicast or unicast.

A multicast match will be signaled if the multicast hash enable bit is set, da[0] is logic 1 and the hash index points to a bit set in the Hash register.

A unicast match will be signaled if the unicast hash enable bit is set, da[0] is logic 0 and the hash index points to a bit set in the Hash register.

To receive all multicast frames, the Hash register should be set with all ones and the multicast hash enable bit should be set in the Network Configuration register.

#### 41.6.10 Copy all Frames (Promiscuous Mode)

If the Copy All Frames bit is set in the Network Configuration register then all frames (except those that are too long, too short, have FCS errors or have GRXER asserted during reception) will be copied to memory. Frames with FCS errors will be copied if bit 26 is set in the Network Configuration register.

#### 41.6.11 Disable Copy of Pause Frames

Pause frames can be prevented from being written to memory by setting the disable copying of pause frames control bit 23 in the Network Configuration register. When set, pause frames are not copied to memory regardless of the Copy All Frames bit, whether a hash match is found, a type ID match is identified or if a destination address match is found.

#### 41.6.12 VLAN Support

The following table describes an Ethernet encoded 802.1Q VLAN tag.

**Table 41-4.** 802.1Q VLAN Tag

TPID (Tag Protocol Identifier) 16 bits	TCI (Tag Control Information) 16 bits
--	---------------------------------------



0x8100	First 3 bits priority, then CFI bit, last 12 bits VID
--------	---

The VLAN tag is inserted at the 13th byte of the frame adding an extra four bytes to the frame. To support these extra four bytes, the GMAC can accept frame lengths up to 1536 bytes by setting bit 8 in the Network Configuration register.

If the VID (VLAN identifier) is null (0x000) this indicates a priority-tagged frame.

The following bits in the receive buffer descriptor status word give information about VLAN tagged frames:-

- Bit 21 set if receive frame is VLAN tagged (i.e., type ID of 0x8100).
- Bit 20 set if receive frame is priority tagged (i.e., type ID of 0x8100 and null VID). (If bit 20 is set, bit 21 will be set also.)
- Bit 19, 18 and 17 set to priority if bit 21 is set.
- Bit 16 set to CFI if bit 21 is set.

The GMAC can be configured to reject all frames except VLAN tagged frames by setting the discard non-VLAN frames bit in the Network Configuration register.

#### 41.6.13 Wake on LAN Support

The receive block supports Wake on LAN by detecting the following events on incoming receive frames:

- Magic packet
- Address Resolution Protocol (ARP) request to the device IP address
- Specific address 1 filter match
- Multicast hash filter match

These events can be individually enabled through bits [19:16] of the Wake on LAN register. Also, for Wake on LAN detection to occur, receive enable must be set in the Network Control register, however a receive buffer does not have to be available.

In case of an ARP request, specific address 1 or multicast filter events will occur even if the frame is errored. For magic packet events, the frame must be correctly formed and error free.

A magic packet event is detected if all of the following are true:

- Magic packet events are enabled through bit 16 of the Wake on LAN register
- The frame's destination address matches specific address 1
- The frame is correctly formed with no errors
- The frame contains at least 6 bytes of 0xFF for synchronization
- There are 16 repetitions of the contents of Specific Address 1 register immediately following the synchronization

An ARP request event is detected if all of the following are true:

- ARP request events are enabled through bit 17 of the Wake on LAN register
- Broadcasts are allowed by bit 5 in the Network Configuration register
- The frame has a broadcast destination address (bytes 1 to 6)
- The frame has a type ID field of 0x0806 (bytes 13 and 14)
- The frame has an ARP operation field of 0x0001 (bytes 21 and 22)
- The least significant 16 bits of the frame's ARP target protocol address (bytes 41 and 42) match the value programmed in bits[15:0] of the Wake on LAN register

The decoding of the ARP fields adjusts automatically if a VLAN tag is detected within the frame. The reserved value of 0x0000 for the Wake on LAN target address value will not cause an ARP request event, even if matched by the frame.

A specific address 1 filter match event will occur if all of the following are true:

- Specific address 1 events are enabled through bit 18 of the Wake on LAN register
- The frame's destination address matches the value programmed in the Specific Address 1 registers

A multicast filter match event will occur if all of the following are true:

- Multicast hash events are enabled through bit 19 of the Wake on LAN register
- Multicast hash filtering is enabled through bit 6 of the Network Configuration register
- The frame destination address matches against the multicast hash filter
- The frame destination address is not a broadcast

#### 41.6.14 IEEE 1588 Support

IEEE 1588 is a standard for precision time synchronization in local area networks. It works with the exchange of special Precision Time Protocol (PTP) frames. The PTP messages can be transported over IEEE 802.3/Ethernet, over Internet Protocol Version 4 or over Internet Protocol Version 6 as described in the annex of IEEE P1588.D2.1.

GMAC output pins indicate the message time-stamp point (asserted on the start packet delimiter and de-asserted at end of frame) for all frames and the passage of PTP event frames (asserted when a PTP event frame is detected and de-asserted at end of frame).

IEEE 802.1AS is a subset of IEEE 1588. One difference is that IEEE 802.1AS uses the Ethernet multicast address 0180C200000E for sync frame recognition whereas IEEE 1588 does not. GMAC is designed to recognize sync frames with both IEEE 802.1AS and IEEE 1588 addresses and so can support both 1588 and 802.1AS frame recognition simultaneously.

Synchronization between Host and Client clocks is a two stage process.

First, the offset between the Host and Client clocks is corrected by the Host sending a sync frame to the Client with a follow up frame containing the exact time the sync frame was sent. Hardware assist modules at the Host and Client side detect exactly when the sync frame was sent by the Host and received by the Client. The Client then corrects its clock to match the Host clock.

Second, the transmission delay between the Host and Client is corrected. The Client sends a delay request frame to the Host which sends a delay response frame in reply. Hardware assist modules at the Host and Client side detect exactly when the delay request frame was sent by the Client and received by the Host. The Client will now have enough information to adjust its clock to account for delay. For example, if the Client was assuming zero delay, the actual delay will be half the difference between the transmit and receive time of the delay request frame (assuming equal transmit and receive times) because the Client clock will be lagging the Host clock by the delay time already.

The time-stamp is taken when the message time-stamp point passes the clock time-stamp point. This can generate an interrupt if enabled (IER). However, MAC Filtering configuration is needed to actually 'copy' the message to memory. For Ethernet, the message time-stamp point is the SFD and the clock time-stamp point is the MII interface. (The IEEE 1588 specification refers to sync and delay\_req messages as event messages as these require time-stamping. These events are captured in the registers TSSx, EFTx and EFRx, respectively. Follow up, delay response and management messages do not require time-stamping and are referred to as general messages.)

1588 version 2 defines two additional PTP event messages. These are the peer delay request (Pdelay\_Req) and peer delay response (Pdelay\_Resp) messages. These events are captured in the registers PEFTx and PEFRx, respectively. These messages are used to calculate the delay on a link. Nodes at both ends of a link send both types of frames (regardless of whether they contain a Host

or Client clock). The Pdelay\_Resp message contains the time at which a Pdelay\_Req was received and is itself an event message. The time at which a Pdelay\_Resp message is received is returned in a Pdelay\_Resp\_Follow\_Up message.

1588 version 2 introduces transparent clocks of which there are two kinds, peer-to-peer (P2P) and end-to-end (E2E). Transparent clocks measure the transit time of event messages through a bridge and amend a correction field within the message to allow for the transit time. P2P transparent clocks additionally correct for the delay in the receive path of the link using the information gathered from the peer delay frames. With P2P transparent clocks delay\_req messages are not used to measure link delay. This simplifies the protocol and makes larger systems more stable.

The GMAC recognizes four different encapsulations for PTP event messages:

1. 1588 version 1 (UDP/IPv4 multicast)
2. 1588 version 2 (UDP/IPv4 multicast)
3. 1588 version 2 (UDP/IPv6 multicast)
4. 1588 version 2 (Ethernet multicast)

**Table 41-5.** Example of Sync Frame in 1588 Version 1 Format

Frame Segment	Value
Preamble/SFD	55555555555555D5
DA (Octets 0-5)	—
SA (Octets 6-11)	—
Type (Octets 12-13)	0800
IP stuff (Octets 14-22)	—
UDP (Octet 23)	11
IP stuff (Octets 24-29)	—
IP DA (Octets 30-32)	E00001
IP DA (Octet 33)	81 or 82 or 83 or 84
Source IP port (Octets 34-35)	—
Dest IP port (Octets 36-37)	013F
Other stuff (Octets 38-42)	—
Version PTP (Octet 43)	01
Other stuff (Octets 44-73)	—
Control (Octet 74)	00
Other stuff (Octets 75-168)	—

**Table 41-6.** Example of Delay Request Frame in 1588 Version 1 Format

Frame Segment	Value
Preamble/SFD	55555555555555D5
DA (Octets 0-5)	—
SA (Octets 6-11)	—
Type (Octets 12-13)	0800
IP stuff (Octets 14-22)	—
UDP (Octet 23)	11
IP stuff (Octets 24-29)	—
IP DA (Octets 30-32)	E00001
IP DA (Octet 33)	81 or 82 or 83 or 84
Source IP port (Octets 34-35)	—
Dest IP port (Octets 36-37)	013F
Other stuff (Octets 38-42)	—

.....continued

Frame Segment	Value
Version PTP (Octet 43)	01
Other stuff (Octets 44-73)	—
Control (Octet 74)	01
Other stuff (Octets 75-168)	—

For 1588 version 1 messages, sync and delay request frames are indicated by the GMAC if the frame type field indicates TCP/IP, UDP protocol is indicated, the destination IP address is 224.0.1.129/130/131 or 132, the destination UDP port is 319 and the control field is correct.

The control field is 0x00 for sync frames and 0x01 for delay request frames.

For 1588 version 2 messages, the type of frame is determined by looking at the message type field in the first byte of the PTP frame. Whether a frame is version 1 or version 2 can be determined by looking at the version PTP field in the second byte of both version 1 and version 2 PTP frames.

In version 2 messages sync frames have a message type value of 0x0, delay\_req have 0x1, Pdelay\_Req have 0x2 and Pdelay\_Resp have 0x3.

**Table 41-7.** Example of Sync Frame in 1588 Version 2 (UDP/IPv4) Format

Frame Segment	Value
Preamble/SFD	55555555555555D5
DA (Octets 0-5)	—
SA (Octets 6-11)	—
Type (Octets 12-13)	0800
IP stuff (Octets 14-22)	—
UDP (Octet 23)	11
IP stuff (Octets 24-29)	—
IP DA (Octets 30-33)	E0000181
Source IP port (Octets 34-35)	—
Dest IP port (Octets 36-37)	013F
Other stuff (Octets 38-41)	—
Message type (Octet 42)	00
Version PTP (Octet 43)	02

**Table 41-8.** Example of Pdelay\_Req Frame in 1588 Version 2 (UDP/IPv4) Format

Frame Segment	Value
Preamble/SFD	55555555555555D5
DA (Octets 0-5)	—
SA (Octets 6-11)	—
Type (Octets 12-13)	0800
IP stuff (Octets 14-22)	—
UDP (Octet 23)	11
IP stuff (Octets 24-29)	—
IP DA (Octets 30-33)	E000006B
Source IP port (Octets 34-35)	—
Dest IP port (Octets 36-37)	013F
Other stuff (Octets 38-41)	—
Message type (Octet 42)	02
Version PTP (Octet 43)	02

**Table 41-9.** Example of Sync Frame in 1588 Version 2 (UDP/IPv6) Format

Frame Segment	Value
Preamble/SFD	55555555555555D5
DA (Octets 0-5)	—
SA (Octets 6-11)	—
Type (Octets 12-13)	86dd
IP stuff (Octets 14-19)	—
UDP (Octet 20)	11
IP stuff (Octets 21-37)	—
IP DA (Octets 38-53)	FF0X00000000018
Source IP port (Octets 54-55)	—
Dest IP port (Octets 56-57)	013F
Other stuff (Octets 58-61)	—
Message type (Octet 62)	00
Other stuff (Octets 63-93)	—
Version PTP (Octet 94)	02

**Table 41-10.** Example of Pdelay\_Resp Frame in 1588 Version 2 (UDP/IPv6) Format

Frame Segment	Value
Preamble/SFD	55555555555555D5
DA (Octets 0-5)	—
SA (Octets 6-11)	—
Type (Octets 12-13)	86dd
IP stuff (Octets 14-19)	—
UDP (Octet 20)	11
IP stuff (Octets 21-37)	—
IP DA (Octets 38-53)	FF0200000000006B
Source IP port (Octets 54-55)	—
Dest IP port (Octets 56-57)	013F
Other stuff (Octets 58-61)	—
Message type (Octet 62)	03
Other stuff (Octets 63-93)	—
Version PTP (Octet 94)	02

For the multicast address 011B19000000 sync and delay request frames are recognized depending on the message type field, 00 for sync and 01 for delay request.

**Table 41-11.** Example of Sync Frame in 1588 Version 2 (Ethernet Multicast) Format

Frame Segment	Value
Preamble/SFD	55555555555555D5
DA (Octets 0-5)	011B19000000
SA (Octets 6-11)	—
Type (Octets 12-13)	88F7
Message type (Octet 14)	00
Version PTP (Octet 15)	02

Pdelay request frames need a special multicast address so they can pass through ports blocked by the spanning tree protocol. For the multicast address 0180C200000E sync, Pdelay\_Req and

Pdelay\_Resp frames are recognized depending on the message type field, 00 for sync, 02 for pdelay request and 03 for pdelay response.

**Table 41-12.** Example of Pdelay\_Req Frame in 1588 Version 2 (Ethernet Multicast) Format

Frame Segment	Value
Preamble/SFD	5555555555555555D5
DA (Octets 0-5)	0180C200000E
SA (Octets 6-11)	—
Type (Octets 12-13)	88F7
Message type (Octet 14)	00
Version PTP (Octet 15)	02

### 41.6.15 Time Stamp Unit

#### Overview

The TSU consists of a timer and registers to capture the time at which PTP event frames cross the message timestamp point. An interrupt is issued when a capture register is updated.

The 1588 time stamp unit (TSU) is implemented as a 94-bit timer.

- The 48 upper bits [93:46] of the timer count seconds and are accessible in the GMAC 1588 Timer Seconds High Register (TSH) and GMAC 1588 Timer Seconds Low Register (TSL).
- The 30 lower bits [45:16] of the timer count nanoseconds and are accessible in the GMAC 1588 Timer Nanoseconds Register (TN).
- The lowest 16 bits [15:0] of the timer count sub-nanoseconds.

The 46 lower bits roll over when they have counted to 1s. An interrupt is generated when the seconds increment. The timer increments by a programmable period (to approximately 15.2fs resolution) with each MCK period. The timer value can be read, written and adjusted with 1ns resolution (incremented or decremented) through the APB interface.

#### Timer Adjustment

The amount by which the timer increments each clock cycle is controlled by the Timer Increment register (TI). Bits [7:0] are the default increment value in nanoseconds. Additional 16 bits of sub-nanosecond resolution are available using the Timer Increment Sub-Nanoseconds register (TISUBN). If the rest of the register is written with zero, the timer increments by the value in [7:0], plus the value of the TISUBN for each clock cycle.

The TISUBN allows a resolution of approximately 15fs.

Bits [15:8] of the increment register are the alternative increment value in nanoseconds, and bits [23:16] are the number of increments after which the alternative increment value is used. If [23:16] are zero the alternative increment value will never be used.

Taking the example of 10.2MHz, there are 102 cycles every 10µs or 51 cycles every 5µs. So a timer with a 10.2MHz clock source is constructed by incrementing by 98ns for fifty cycles and then incrementing by 100ns (98ns × 50 + 100ns = 5000ns). This is programmed by writing the value 0x00326462 to the Timer Increment register (TI).

In a second example, a 49.8 MHz clock source requires 20ns for 248 cycles, followed by an increment of 40ns (20ns × 248 + 40ns = 5000ns). This is programmed by writing the value 0x00F82814 to the TI register.

The Number of Increments bit field in the TI register is 8 bit in size, so frequencies up to 50MHz are supported with 200kHz resolution.

Without the alternative increment field the period of the clock would be limited to an integer number of nanoseconds, resulting in supported clock frequencies of 8, 10, 20, 25, 40, 50, 100, 125, 200 and 250 MHz.

There are eight additional 80-bit registers that capture the time at which PTP event frames are transmitted and received. An interrupt is issued when these registers are updated. The TSU timer count value can be compared to a programmable comparison value. For the comparison, the 48 bits of the seconds value and the upper 22 bits of the nanoseconds value are used. An internal signal (GTSUCOMP) is output from the core to indicate when the TSU timer count value is equal to the comparison value stored in the TSU timer comparison value registers (GMAC.NSC, GMAC.SCL, and GMAC.SCH). An interrupt can also be generated (if enabled) when the TSU timer count value and comparison value are equal, mapped to bit 29 of the interrupt status register.

#### 41.6.16 MAC 802.3 Pause Frame Support

**Note:** Refer to the Clause 31, and Annex 31A and 31B of the IEEE standard 802.3 for a full description of MAC 802.3 pause operation.

The following table shows the start of a MAC 802.3 pause frame.

**Table 41-13.** Start of an 802.3 Pause Frame

Address		Type (MAC Control Frame)	Pause	
Destination	Source		Opcode	Time
0x0180C200001	6 bytes	0x8808	0x0001	2 bytes

The GMAC supports both hardware controlled pause of the transmitter, upon reception of a pause frame, and hardware generated pause frame transmission.

##### 41.6.16.1 802.3 Pause Frame Reception

The bit 13 of the Network Configuration register is the pause enable control for reception. If this bit is set, transmission will pause if a non zero pause quantum frame is received.

If a valid pause frame is received, then the Pause Time register is updated with the new frame's pause time, regardless of whether a previous pause frame is active or not. An interrupt (either bit 12 or bit 13 of the Interrupt Status register) is triggered when a pause frame is received, but only if the interrupt has been enabled (bit 12 and bit 13 of the Interrupt Mask register). Pause frames received with non zero quantum are indicated through the interrupt bit 12 of the Interrupt Status register. Pause frames received with zero quantum are indicated on bit 13 of the Interrupt Status register.

Once the Pause Time register is loaded and the frame currently being transmitted has been sent, no new frames are transmitted until the pause time reaches zero. The loading of a new pause time, and hence the pausing of transmission, only occurs when the GMAC is configured for full duplex operation. If the GMAC is configured for half duplex there will be no transmission pause, but the pause frame received interrupt will still be triggered. A valid pause frame is defined as having a destination address that matches either the address stored in Specific Address register '1' or if it matches the reserved address of 0x0180C200001. It must also have the MAC control frame type ID of 0x8808 and have the pause opcode of 0x0001.

Pause frames that have frame check sequence (FCS) or other errors will be treated as invalid and will be discarded. Valid pause frames received will increment the pause frames received statistic register.

The pause time register decrements every 512 bit times once the transmission has stopped. For test purposes, the retry test bit can be set (bit 12 in the Network Configuration register) which causes the Pause Time register to decrement every GTXCK cycle once transmission has stopped.

The interrupt (bit 13 in the Interrupt Status register) is asserted whenever the Pause Time register decrements to zero (assuming it has been enabled by bit 13 in the Interrupt Mask register). This interrupt is also set when a zero quantum pause frame is received.

### 41.6.16.2 802.3 Pause Frame Transmission

Automatic transmission of pause frames is supported through the transmit pause frame bits of the Network Control register. If either bit 11 or bit 12 of the Network Control register is written with logic 1, an 802.3 pause frame will be transmitted, providing full duplex is selected in the Network Configuration register and the transmit block is enabled in the Network Control register.

Pause frame transmission will happen immediately if transmit is inactive or if transmit is active between the current frame and the next frame due to be transmitted.

Transmitted pause frames comprise the following:

- A destination address of 01-80-C2-00-00-01
- A source address taken from Specific Address register 1
- A type ID of 88-08 (MAC control frame)
- A pause opcode of 00-01
- A pause quantum register
- Fill of 00 to take the frame to minimum frame length
- Valid FCS

The pause quantum used in the generated frame will depend on the trigger source for the frame as follows:

- If bit 11 is written with a '1', the pause quantum will be taken from the Transmit Pause Quantum register. The Transmit Pause Quantum register resets to a value of 0xFFFF giving maximum pause quantum as default.
- If bit 12 is written with a '1', the pause quantum will be zero.

After transmission, a pause frame transmitted interrupt will be generated (bit 14 of the Interrupt Status register) and the only statistics register that will be incremented will be the Pause Frames Transmitted register.

Pause frames can also be transmitted by the MAC using normal frame transmission methods.

### 41.6.17 Energy Efficient Ethernet Support

#### Features

- Energy Efficient Ethernet according to IEEE 802.3az
- A system's transmit path can enter a low power mode if there is nothing to transmit.
- A PHY can detect whether its link partner's transmit path is in low power mode, and configure its own receive path to enter low power mode.
- Link remains up during lower power mode and no frames are dropped.
- Asymmetric, one direction can be in low power mode while the other is transmitting normally.
- LPI (Low Power Idle) signaling is used to control entry and exit to and from low power modes.  
**Note:** LPI signaling can only take place if both sides have indicated support for it through auto-negotiation.

#### Operation

- Low power control is done at the MII (reconciliation sublayer).
- As an architectural convenience in writing the 802.3az it is assumed that transmission is deferred by asserting carrier sense - in practice it will not be done this way. This system will know when it has nothing to transmit and only enter low power mode when it is not transmitting.
- LPI should not be requested unless the link has been up for at least one second.
- LPI is signaled on the MII transmit path by asserting 0x01 on txd with tx\_en low and tx\_er high.



- A PHY on seeing LPI requested on the MII will send the sleep signal before going quiet. After going quiet it will periodically emit refresh signals.
- The sleep, quiet and refresh periods are defined in 802.3az, Table 78-2.
- LPI mode ends by transmitting normal idle for the wake time. There is a default time for this but it can be adjusted in software using the Link Layer Discovery Protocol (LLDP) described in 802.3az, Clause 79.
- LPI is indicated at the receive side when sleep and refresh signaling has been detected.

#### 41.6.18 802.1Qav Support - Credit-based Shaping

A credit-based shaping algorithm is available on the two highest priority queues and is defined in the standard 802.1Qav: Forwarding and Queuing Enhancements for Time-Sensitive Streams. This allows traffic on these queues to be limited and to allow other queues to transmit.

Traffic shaping is enabled via the CBS (Credit Based Shaping) Control register. This enables a counter which stores the amount of transmit 'credit', measured in bytes that a particular queue has. A queue may only transmit if it has non-negative credit. If a queue has data to send, but is held off from doing as another queue is transmitting, then credit will accumulate in the credit counter at the rate defined in the IdleSlope register (CBSISQx) for that queue.

**portTransmitRate** is the transmission rate, in bits per second, that the underlying MAC service that supports transmission through the Port provides. The value of this parameter is determined by the operation of the MAC. IdleSlope is the rate of change of increasing credit when waiting to transmit and must be less than the value of the portTransmitRate.

**IdleSlope** is the rate of change of credit when waiting to transmit and must be less than the value of the portTransmitRate.

The max value of IdleSlope (or sendSlope) is  $(\text{portTransmitRate} / \text{bits\_per\_MII\_Clock})$ .

In case of 100 Mbps, maximum IdleSlope =  $(100 \text{ Mbps} / 4) = 0x17D7840$ .

When this queue is transmitting the credit counter is decremented at the rate of sendSlope which is defined as  $(\text{portTransmitRate} - \text{IdleSlope})$ . A queue can accumulate negative credit when transmitting which will hold off any other transfers from that queue until credit returns to a non-negative value. No transfers are halted when a queue's credit becomes negative; it will accumulate negative credit until the transfer completes.

The highest priority queue always has priority regardless of which queue has the most credit.

#### 41.6.19 PHY Interface

Different PHY interfaces are supported by the Ethernet MAC:

- MII
- RMII

The MII interface is provided for 10/100 operation and uses txd[3:0] and rxd[3:0]. The RMII interface is provided for 10/100 operation and uses txd[1:0] and rxd[1:0].

#### 41.6.20 10/100 Operation

The 10/100 Mbps speed bit in the Network Configuration register is used to select between 10 Mbps and 100 Mbps.

#### 41.6.21 Jumbo Frames

The jumbo frames enable bit in the Network Configuration register allows the GMAC, in its default configuration, to receive jumbo frames up to 10240 bytes in size. This operation does not form part of the IEEE 802.3 specification and is normally disabled. When jumbo frames are enabled, frames received with a frame size greater than 10240 bytes are discarded.

## 41.7 Programming Interface

### 41.7.1 Initialization

#### 41.7.1.1 Configuration

Initialization of the GMAC configuration (e.g., loop back mode, frequency ratios) must be done while the transmit and receive circuits are disabled. See the description of the Network Control register and Network Configuration register earlier in this document.

To change loop back mode, the following sequence of operations must be followed:

1. Write to Network Control register to disable transmit and receive circuits.
2. Write to Network Control register to change loop back mode.
3. Write to Network Control register to re-enable transmit or receive circuits.

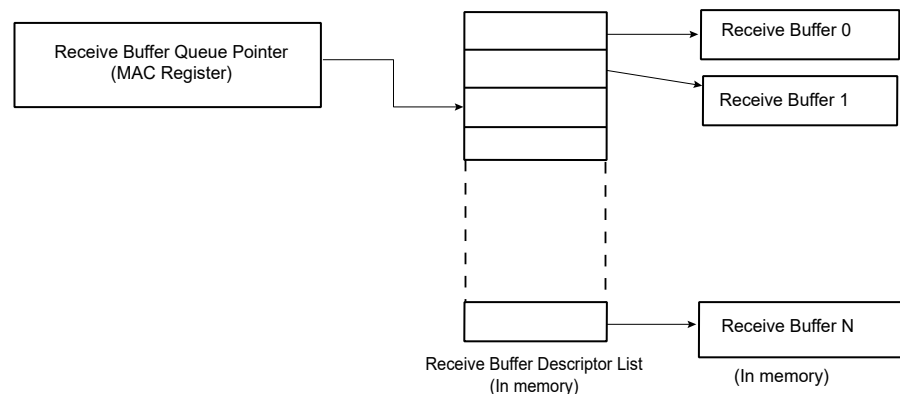
Note: These writes to the Network Control register cannot be combined in any way.

#### 41.7.1.2 Receive Buffer List

Receive data is written to areas of data (i.e., buffers) in system memory. These buffers are listed in another data structure that also resides in main memory. This data structure (receive buffer queue) is a sequence of descriptor entries as defined in [Table 1-6 "Receive Buffer Descriptor Entry"](#).

The Receive Buffer Queue Pointer register points to this data structure.

**Figure 41-3.** Receive Buffer List



To create the list of buffers:

1. Allocate a number (N) of buffers of X bytes in system memory, where X is the DMA buffer length programmed in the DMA Configuration register.
2. Allocate an area 8N bytes for the receive buffer descriptor list in system memory and create N entries in this list. Mark all entries in this list as owned by GMAC, i.e., bit 0 of word 0 set to 0.
3. Mark the last descriptor in the queue with the wrap bit (bit 1 in word 0 set to 1).
4. Write address of receive buffer descriptor list and control information to GMAC register receive buffer queue pointer
5. The receive circuits can then be enabled by writing to the address recognition registers and the Network Control register.

#### 41.7.1.3 Transmit Buffer List

Transmit data is read from areas of data (the buffers) in system memory. These buffers are listed in another data structure that also resides in main memory. This data structure (Transmit Buffer Queue) is a sequence of descriptor entries as defined in [Table 1-7 "Transmit Buffer Descriptor Entry"](#).

The Transmit Buffer Queue Pointer register points to this data structure.

To create this list of buffers:

1. Allocate a number (N) of buffers of between 1 and 2047 bytes of data to be transmitted in system memory. Up to 128 buffers per frame are allowed.
2. Allocate an area 8N bytes for the transmit buffer descriptor list in system memory and create N entries in this list. Mark all entries in this list as owned by GMAC, i.e., bit 31 of word 1 set to 0.
3. Mark the last descriptor in the queue with the wrap bit (bit 30 in word 1 set to 1).
4. Write address of transmit buffer descriptor list and control information to GMAC register transmit buffer queue pointer.
5. The transmit circuits can then be enabled by writing to the Network Control register.

#### 41.7.1.4 Address Matching

The GMAC register pair hash address and the four Specific Address register pairs must be written with the required values. Each register pair comprises of a bottom register and top register, with the bottom register being written first. The address matching is disabled for a particular register pair after the bottom register has been written and re-enabled when the top register is written. Each register pair may be written at any time, regardless of whether the receive circuits are enabled or disabled.

As an example, to set Specific Address register 1 to recognize destination address 21:43:65:87:A9:CB, the following values are written to Specific Address register 1 bottom and Specific Address register 1 top:

- Specific Address register 1 bottom bits 31:0 (0x98): 0x8765\_4321.
- Specific Address register 1 top bits 31:0 (0x9C): 0x0000\_CBA9.

#### 41.7.1.5 PHY Maintenance

The PHY Maintenance register is implemented as a shift register. Writing to the register starts a shift operation which is signalled as complete when bit two is set in the Network Status register (about 2000 MCK cycles later when bits 18:16 are set to 010 in the Network Configuration register). An interrupt is generated as this bit is set.

During this time, the MSB of the register is output on the MDIO pin and the LSB updated from the MDIO pin with each Management Data Clock (MDC) cycle. This causes the transmission of a PHY management frame on MDIO. See section 22.2.4.5 of the IEEE 802.3 standard.

Reading during the shift operation will return the current contents of the shift register. At the end of the management operation the bits will have shifted back to their original locations. For a read operation the data bits are updated with data read from the PHY. It is important to write the correct values to the register to ensure a valid PHY management frame is produced.

The Management Data Clock (MDC) should not toggle faster than 2.5 MHz (minimum period of 400 ns), as defined by the IEEE 802.3 standard. MDC is generated by dividing down MCK. Three bits in the Network Configuration register determine by how much MCK should be divided to produce MDC.

#### 41.7.1.6 Interrupts

There are 18 interrupt conditions that are detected within the GMAC. The conditions are ORed to make a single interrupt. Depending on the overall system design this may be passed through a further level of interrupt collection (interrupt controller). On receipt of the interrupt signal, the CPU enters the interrupt handler. Refer to the device interrupt controller documentation to identify that it is the GMAC that is generating the interrupt. To ascertain which interrupt, read the Interrupt Status register. Note that in the default configuration this register will clear itself after being read, though this may be configured to be write-one-to-clear if desired.

At reset all interrupts are disabled. To enable an interrupt, write to Interrupt Enable register with the pertinent interrupt bit set to 1. To disable an interrupt, write to Interrupt Disable register with the pertinent interrupt bit set to 1. To check whether an interrupt is enabled or disabled, read Interrupt Mask register. If the bit is set to 1, the interrupt is disabled.

### 41.7.1.7 Transmitting Frames

The procedure to set up a frame for transmission is the following:

1. Enable transmit in the Network Control register.
2. Allocate an area of system memory for transmit data. This does not have to be contiguous, varying byte lengths can be used if they conclude on byte borders.
3. Set-up the transmit buffer list by writing buffer addresses to word zero of the transmit buffer descriptor entries and control and length to word one.
4. Write data for transmission into the buffers pointed to by the descriptors.
5. Write the address of the first buffer descriptor to transmit buffer descriptor queue pointer.
6. Enable appropriate interrupts.
7. Write to the transmit start bit (TSTART) in the Network Control register.

### 41.7.1.8 Receiving Frames

When a frame is received and the receive circuits are enabled, the GMAC checks the address and, in the following cases, the frame is written to system memory:

- If it matches one of the four Specific Address registers.
- If it matches one of the four type ID registers.
- If it matches the hash address function.
- If it is a broadcast address (0xFFFFFFFF) and broadcasts are allowed.
- If the GMAC is configured to “copy all frames”.

The register receive buffer queue pointer points to the next entry in the receive buffer descriptor list and the GMAC uses this as the address in system memory to write the frame to.

Once the frame has been completely and successfully received and written to system memory, the GMAC then updates the receive buffer descriptor entry (see [Table 1-6 “Receive Buffer Descriptor Entry”](#)) with the reason for the address match and marks the area as being owned by software. Once this is complete, a receive complete interrupt is set. Software is then responsible for copying the data to the application area and releasing the buffer (by writing the ownership bit back to 0).

If the GMAC is unable to write the data at a rate to match the incoming frame, then a receive overrun interrupt is set. If there is no receive buffer available, i.e., the next buffer is still owned by software, a receive buffer not available interrupt is set. If the frame is not successfully received, a statistics register is incremented and the frame is discarded without informing software.

## 41.7.2 Statistics Registers

Statistics registers are described in the User Interface beginning with [Section 1.8.48 “GMAC Octets Transmitted Low Register”](#) and ending with [Section 1.8.92 “GMAC UDP Checksum Errors Register”](#).

The statistics register block begins at 0x100 and runs to 0x1B0, and comprises the registers listed below.

Octets Transmitted Low Register	Broadcast Frames Received Register
Octets Transmitted High Register	Multicast Frames Received Register
Frames Transmitted Register	Pause Frames Received Register
Broadcast Frames Transmitted Register	64 Byte Frames Received Register
Multicast Frames Transmitted Register	65 to 127 Byte Frames Received Register
Pause Frames Transmitted Register	128 to 255 Byte Frames Received Register
64 Byte Frames Transmitted Register	256 to 511 Byte Frames Received Register
65 to 127 Byte Frames Transmitted Register	512 to 1023 Byte Frames Received Register
128 to 255 Byte Frames Transmitted Register	1024 to 1518 Byte Frames Received Register

256 to 511 Byte Frames Transmitted Register	1519 to Maximum Byte Frames Received Register
512 to 1023 Byte Frames Transmitted Register	Undersize Frames Received Register
1024 to 1518 Byte Frames Transmitted Register	Oversize Frames Received Register
Greater Than 1518 Byte Frames Transmitted Register	Jabbers Received Register
Transmit Underruns Register	Frame Check Sequence Errors Register
Single Collision Frames Register	Length Field Frame Errors Register
Multiple Collision Frames Register	Receive Symbol Errors Register
Excessive Collisions Register	Alignment Errors Register
Late Collisions Register	Receive Resource Errors Register
Deferred Transmission Frames Register	Receive Overrun Register
Carrier Sense Errors Register	IP Header Checksum Errors Register
Octets Received Low Register	TCP Checksum Errors Register
Octets Received High Register	UDP Checksum Errors Register
Frames Received Register	

These registers reset to zero on a read and stick at all ones when they count to their maximum value. They should be read frequently enough to prevent loss of data.

The receive statistics registers are only incremented when the receive enable bit (RXEN) is set in the Network Control register.

Once a statistics register has been read, it is automatically cleared. When reading the Octets Transmitted and Octets Received registers, bits 31:0 should be read prior to bits 47:32 to ensure reliable operation.

## 41.8 Register Summary

Offset	Name	Bit Pos.	7	6	5	4	3	2	1	0	
0x00	NCR	7:0	WESTAT	INCSTAT	CLRSTAT	MPE	TXEN	RXEN	LBL		
		15:8	SRTSM			TXZQPF	TXPF	THALT	TSTART	BP	
		23:16					LPI	FNP	TXBPBF	ENPBPR	
		31:24									
0x04	NCFGR	7:0	UNIHEN	MTIHEN	NBC	CAF	JFRAME	DNVLAN	FD	SPD	
		15:8	RXBUFO[1:0]		PEN	RTY				MAXFS	
		23:16	DCPF	DBW[1:0]		CLK[2:0]			RFCS	LFERD	
		31:24		IRXER	RXBP	IPGSEN		IRXFCS	EFRHD	RXCOEN	
0x08	NSR	7:0						IDLE	MDIO		
		15:8									
		23:16									
		31:24									
0x0C	UR	7:0								MII	
		15:8									
		23:16									
		31:24									
0x10	DCFGR	7:0	ESPA	ESMA		FBLDO[4:0]					
		15:8				TXCOEN	TXPBMS	RXBMS[1:0]			
		23:16	DRBS[7:0]								
		31:24								DDRP	
0x14	TSR	7:0		UND	TXCOMP	TFC	TXGO	RLE	COL	UBR	
		15:8								HRESP	
		23:16									
		31:24									
0x18	RBQB	7:0	ADDR[5:0]								
		15:8	ADDR[13:6]								
		23:16	ADDR[21:14]								
		31:24	ADDR[29:22]								
0x1C	TBQB	7:0	ADDR[5:0]								
		15:8	ADDR[13:6]								
		23:16	ADDR[21:14]								
		31:24	ADDR[29:22]								
0x20	RSR	7:0					HNO	RXOVR	REC	BNA	
		15:8									
		23:16									
		31:24									
0x24	ISR	7:0	TCOMP	TFC	RLEX	TUR	TXUBR	RXUBR	RCOMP	MFS	
		15:8		PFTR	PTZ	PFNZ	HRESP	ROVR			
		23:16	PDRSFR	PDRQFR	SFT	DRQFT	SFR	DRQFR			
		31:24			TSUCMP	WOL	RXLPISBC	SRI	PDRSFT	PDRQFT	
0x28	IER	7:0	TCOMP	TFC	RLEX	TUR	TXUBR	RXUBR	RCOMP	MFS	
		15:8	EXINT	PFTR	PTZ	PFNZ	HRESP	ROVR			
		23:16	PDRSFR	PDRQFR	SFT	DRQFT	SFR	DRQFR			
		31:24			TSUCMP	WOL	RXLPISBC	SRI	PDRSFT	PDRQFT	
0x2C	IDR	7:0	TCOMP	TFC	RLEX	TUR	TXUBR	RXUBR	RCOMP	MFS	
		15:8	EXINT	PFTR	PTZ	PFNZ	HRESP	ROVR			
		23:16	PDRSFR	PDRQFR	SFT	DRQFT	SFR	DRQFR			
		31:24			TSUCMP	WOL	RXLPISBC	SRI	PDRSFT	PDRQFT	
0x30	IMR	7:0	TCOMP	TFC	RLEX	TUR	TXUBR	RXUBR	RCOMP	MFS	
		15:8	EXINT	PFTR	PTZ	PFNZ	HRESP	ROVR			
		23:16	PDRSFR	PDRQFR	SFT	DRQFT	SFR	DRQFR			
		31:24			TSUCMP	WOL	RXLPISBC	SRI	PDRSFT	PDRQFT	
0x34	MAN	7:0	DATA[7:0]								
		15:8	DATA[15:8]								
		23:16	PHYA[0]	REGA[4:0]					WTN[1:0]		
		31:24	WZO	CLTTO	OP[1:0]			PHYA[4:1]			

.....continued										
Offset	Name	Bit Pos.	7	6	5	4	3	2	1	0
0x38	RPQ	7:0	RPQ[7:0]							
		15:8	RPQ[15:8]							
		23:16								
		31:24								
0x3C	TPQ	7:0	TPQ[7:0]							
		15:8	TPQ[15:8]							
		23:16								
		31:24								
0x40	TPSF	7:0	TPB1ADR[7:0]							TPB1ADR[9:8]
		15:8								
		23:16								
		31:24	ENTXP							
0x44	RPSF	7:0	RPB1ADR[7:0]							RPB1ADR[9:8]
		15:8								
		23:16								
		31:24	ENRXP							
0x48	RJFML	7:0	FML[7:0]							
		15:8			FML[13:8]					
		23:16								
		31:24								
0x4C ... 0x7F	Reserved									
0x80	HRB	7:0	ADDR[7:0]							
		15:8	ADDR[15:8]							
		23:16	ADDR[23:16]							
		31:24	ADDR[31:24]							
0x84	HRT	7:0	ADDR[7:0]							
		15:8	ADDR[15:8]							
		23:16	ADDR[23:16]							
		31:24	ADDR[31:24]							
0x88	SAB0	7:0	ADDR[7:0]							
		15:8	ADDR[15:8]							
		23:16	ADDR[23:16]							
		31:24	ADDR[31:24]							
0x8C	SAT0	7:0	ADDR[7:0]							
		15:8	ADDR[15:8]							
		23:16								
		31:24								
0x90	SAB1	7:0	ADDR[7:0]							
		15:8	ADDR[15:8]							
		23:16	ADDR[23:16]							
		31:24	ADDR[31:24]							
0x94	SAT1	7:0	ADDR[7:0]							
		15:8	ADDR[15:8]							
		23:16								
		31:24								
0x98	SAB2	7:0	ADDR[7:0]							
		15:8	ADDR[15:8]							
		23:16	ADDR[23:16]							
		31:24	ADDR[31:24]							
0x9C	SAT2	7:0	ADDR[7:0]							
		15:8	ADDR[15:8]							
		23:16								
		31:24								
0xA0	SAB3	7:0	ADDR[7:0]							
		15:8	ADDR[15:8]							
		23:16	ADDR[23:16]							
		31:24	ADDR[31:24]							

.....continued											
Offset	Name	Bit Pos.	7	6	5	4	3	2	1	0	
0xA4	SAT3	7:0	ADDR[7:0]								
		15:8	ADDR[15:8]								
		23:16									
		31:24									
0xA8	TIDM0	7:0	TID[7:0]								
		15:8	TID[15:8]								
		23:16									
		31:24	ENID								
0xAC	TIDM1	7:0	TID[7:0]								
		15:8	TID[15:8]								
		23:16									
		31:24	ENID								
0xB0	TIDM2	7:0	TID[7:0]								
		15:8	TID[15:8]								
		23:16									
		31:24	ENID								
0xB4	TIDM3	7:0	TID[7:0]								
		15:8	TID[15:8]								
		23:16									
		31:24	ENID								
0xB8	WOL	7:0	IP[7:0]								
		15:8	IP[15:8]								
		23:16					MTI	SA1		ARP	MAG
		31:24									
0xBC	IPGS	7:0	FL[7:0]								
		15:8	FL[15:8]								
		23:16									
		31:24									
0xC0	SVLAN	7:0	VLAN_TYPE[7:0]								
		15:8	VLAN_TYPE[15:8]								
		23:16									
		31:24	ESVLAN								
0xC4	TPFCP	7:0	PEV[7:0]								
		15:8	PQ[7:0]								
		23:16									
		31:24									
0xC8	SAMB1	7:0	ADDR[7:0]								
		15:8	ADDR[15:8]								
		23:16	ADDR[23:16]								
		31:24	ADDR[31:24]								
0xCC	SAMT1	7:0	ADDR[7:0]								
		15:8	ADDR[15:8]								
		23:16									
		31:24									
0xD0 ... 0xDB	Reserved										
0xDC	NSC	7:0	NANOSEC[7:0]								
		15:8	NANOSEC[15:8]								
		23:16					NANOSEC[20:16]				
		31:24									
0xE0	SCL	7:0	SEC[7:0]								
		15:8	SEC[15:8]								
		23:16	SEC[23:16]								
		31:24	SEC[31:24]								
0xE4	SCH	7:0	SEC[7:0]								
		15:8	SEC[15:8]								
		23:16									
		31:24									



.....continued										
Offset	Name	Bit Pos.	7	6	5	4	3	2	1	0
0xE8	EFTSH	7:0	RUD[7:0]							
		15:8	RUD[15:8]							
		23:16								
		31:24								
0xEC	EFRSH	7:0	RUD[7:0]							
		15:8	RUD[15:8]							
		23:16								
		31:24								
0xF0	PEFTSH	7:0	RUD[7:0]							
		15:8	RUD[15:8]							
		23:16								
		31:24								
0xF4	PEFRSH	7:0	RUD[7:0]							
		15:8	RUD[15:8]							
		23:16								
		31:24								
0xF8 ... 0xFF	Reserved									
0x0100	OTLO	7:0	TXO[7:0]							
		15:8	TXO[15:8]							
		23:16	TXO[23:16]							
		31:24	TXO[31:24]							
0x0104	OTHI	7:0	TXO[7:0]							
		15:8	TXO[15:8]							
		23:16								
		31:24								
0x0108	FT	7:0	FTX[7:0]							
		15:8	FTX[15:8]							
		23:16	FTX[23:16]							
		31:24	FTX[31:24]							
0x010C	BCFT	7:0	BFTX[7:0]							
		15:8	BFTX[15:8]							
		23:16	BFTX[23:16]							
		31:24	BFTX[31:24]							
0x0110	MFT	7:0	MFTX[7:0]							
		15:8	MFTX[15:8]							
		23:16	MFTX[23:16]							
		31:24	MFTX[31:24]							
0x0114	PFT	7:0	PFTX[7:0]							
		15:8	PFTX[15:8]							
		23:16								
		31:24								
0x0118	BFT64	7:0	NFTX[7:0]							
		15:8	NFTX[15:8]							
		23:16	NFTX[23:16]							
		31:24	NFTX[31:24]							
0x011C	TBFT127	7:0	NFTX[7:0]							
		15:8	NFTX[15:8]							
		23:16	NFTX[23:16]							
		31:24	NFTX[31:24]							
0x0120	TBFT255	7:0	NFTX[7:0]							
		15:8	NFTX[15:8]							
		23:16	NFTX[23:16]							
		31:24	NFTX[31:24]							
0x0124	TBFT511	7:0	NFTX[7:0]							
		15:8	NFTX[15:8]							
		23:16	NFTX[23:16]							
		31:24	NFTX[31:24]							

.....continued											
Offset	Name	Bit Pos.	7	6	5	4	3	2	1	0	
0x0128	TBFT1023	7:0					NFTX[7:0]				
		15:8					NFTX[15:8]				
		23:16					NFTX[23:16]				
		31:24					NFTX[31:24]				
0x012C	TBFT1518	7:0					NFTX[7:0]				
		15:8					NFTX[15:8]				
		23:16					NFTX[23:16]				
		31:24					NFTX[31:24]				
0x0130	GTBFT1518	7:0					NFTX[7:0]				
		15:8					NFTX[15:8]				
		23:16					NFTX[23:16]				
		31:24					NFTX[31:24]				
0x0134	TUR	7:0					TXUNR[7:0]				
		15:8					TXUNR[9:8]				
		23:16									
		31:24									
0x0138	SCF	7:0					SCOL[7:0]				
		15:8					SCOL[15:8]				
		23:16					SCOL[17:16]				
		31:24									
0x013C	MCF	7:0					MCOL[7:0]				
		15:8					MCOL[15:8]				
		23:16					MCOL[17:16]				
		31:24									
0x0140	EC	7:0					XCOL[7:0]				
		15:8					XCOL[9:8]				
		23:16									
		31:24									
0x0144	LC	7:0					LCOL[7:0]				
		15:8					LCOL[9:8]				
		23:16									
		31:24									
0x0148	DTF	7:0					DEFT[7:0]				
		15:8					DEFT[15:8]				
		23:16					DEFT[17:16]				
		31:24									
0x014C	CSE	7:0					CSR[7:0]				
		15:8					CSR[9:8]				
		23:16									
		31:24									
0x0150	ORLO	7:0					RXO[7:0]				
		15:8					RXO[15:8]				
		23:16					RXO[23:16]				
		31:24					RXO[31:24]				
0x0154	ORHI	7:0					RXO[7:0]				
		15:8					RXO[15:8]				
		23:16									
		31:24									
0x0158	FR	7:0					FRX[7:0]				
		15:8					FRX[15:8]				
		23:16					FRX[23:16]				
		31:24					FRX[31:24]				
0x015C	BCFR	7:0					BFRX[7:0]				
		15:8					BFRX[15:8]				
		23:16					BFRX[23:16]				
		31:24					BFRX[31:24]				
0x0160	MFR	7:0					MFRX[7:0]				
		15:8					MFRX[15:8]				
		23:16					MFRX[23:16]				
		31:24					MFRX[31:24]				

.....continued										
Offset	Name	Bit Pos.	7	6	5	4	3	2	1	0
0x0164	PFR	7:0	PFRX[7:0]							
		15:8	PFRX[15:8]							
		23:16								
		31:24								
0x0168	BFR64	7:0	NFRX[7:0]							
		15:8	NFRX[15:8]							
		23:16	NFRX[23:16]							
		31:24	NFRX[31:24]							
0x016C	TBFR127	7:0	NFRX[7:0]							
		15:8	NFRX[15:8]							
		23:16	NFRX[23:16]							
		31:24	NFRX[31:24]							
0x0170	TBFR255	7:0	NFRX[7:0]							
		15:8	NFRX[15:8]							
		23:16	NFRX[23:16]							
		31:24	NFRX[31:24]							
0x0174	TBFR511	7:0	NFRX[7:0]							
		15:8	NFRX[15:8]							
		23:16	NFRX[23:16]							
		31:24	NFRX[31:24]							
0x0178	TBFR1023	7:0	NFRX[7:0]							
		15:8	NFRX[15:8]							
		23:16	NFRX[23:16]							
		31:24	NFRX[31:24]							
0x017C	TBFR1518	7:0	NFRX[7:0]							
		15:8	NFRX[15:8]							
		23:16	NFRX[23:16]							
		31:24	NFRX[31:24]							
0x0180	TMXBFR	7:0	NFRX[7:0]							
		15:8	NFRX[15:8]							
		23:16	NFRX[23:16]							
		31:24	NFRX[31:24]							
0x0184	UFR	7:0	UFRX[7:0]							
		15:8								UFRX[9:8]
		23:16								
		31:24								
0x0188	OFR	7:0	OFRX[7:0]							
		15:8								OFRX[9:8]
		23:16								
		31:24								
0x018C	JR	7:0	JRX[7:0]							
		15:8								JRX[9:8]
		23:16								
		31:24								
0x0190	FCSE	7:0	FCKR[7:0]							
		15:8								FCKR[9:8]
		23:16								
		31:24								
0x0194	LFFE	7:0	LFRX[7:0]							
		15:8								LFRX[9:8]
		23:16								
		31:24								
0x0198	RSE	7:0	RXSE[7:0]							
		15:8								RXSE[9:8]
		23:16								
		31:24								
0x019C	AE	7:0	AER[7:0]							
		15:8								AER[9:8]
		23:16								
		31:24								

.....continued										
Offset	Name	Bit Pos.	7	6	5	4	3	2	1	0
0x01A0	RRE	7:0	RXRER[7:0]							
		15:8	RXRER[15:8]							
		23:16	RXRER[17:16]							
		31:24								
0x01A4	ROE	7:0	RXOVR[7:0]							
		15:8	RXOVR[9:8]							
		23:16								
		31:24								
0x01A8	IHCE	7:0	HCKER[7:0]							
		15:8								
		23:16								
		31:24								
0x01AC	TCE	7:0	TCKER[7:0]							
		15:8								
		23:16								
		31:24								
0x01B0	UCE	7:0	UCKER[7:0]							
		15:8								
		23:16								
		31:24								
0x01B4 ... 0x01BB	Reserved									
0x01BC	TISUBN	7:0	LSBTIR[7:0]							
		15:8	LSBTIR[15:8]							
		23:16								
		31:24								
0x01C0	TSH	7:0	TCS[7:0]							
		15:8	TCS[15:8]							
		23:16								
		31:24								
0x01C4 ... 0x01C7	Reserved									
0x01C8	TSSSL	7:0	VTS[7:0]							
		15:8	VTS[15:8]							
		23:16	VTS[23:16]							
		31:24	VTS[31:24]							
0x01CC	TSSN	7:0	VTN[7:0]							
		15:8	VTN[15:8]							
		23:16	VTN[23:16]							
		31:24	VTN[29:24]							
0x01D0	TSL	7:0	TCS[7:0]							
		15:8	TCS[15:8]							
		23:16	TCS[23:16]							
		31:24	TCS[31:24]							
0x01D4	TN	7:0	TNS[7:0]							
		15:8	TNS[15:8]							
		23:16	TNS[23:16]							
		31:24	TNS[29:24]							
0x01D8	TA	7:0	ITDT[7:0]							
		15:8	ITDT[15:8]							
		23:16	ITDT[23:16]							
		31:24	ADJ							
0x01DC	TI	7:0	CNS[7:0]							
		15:8	ACNS[7:0]							
		23:16	NIT[7:0]							
		31:24								

.....continued											
Offset	Name	Bit Pos.	7	6	5	4	3	2	1	0	
0x01E0	EFTSL	7:0								RUD[7:0]	
		15:8								RUD[15:8]	
		23:16									RUD[23:16]
		31:24									RUD[31:24]
0x01E4	EFTN	7:0								RUD[7:0]	
		15:8								RUD[15:8]	
		23:16									RUD[23:16]
		31:24									RUD[29:24]
0x01E8	EFRSL	7:0								RUD[7:0]	
		15:8								RUD[15:8]	
		23:16									RUD[23:16]
		31:24									RUD[31:24]
0x01EC	EFRN	7:0								RUD[7:0]	
		15:8								RUD[15:8]	
		23:16									RUD[23:16]
		31:24									RUD[29:24]
0x01F0	PEFTSL	7:0								RUD[7:0]	
		15:8								RUD[15:8]	
		23:16									RUD[23:16]
		31:24									RUD[31:24]
0x01F4	PEFTN	7:0								RUD[7:0]	
		15:8								RUD[15:8]	
		23:16									RUD[23:16]
		31:24									RUD[29:24]
0x01F8	PEFRSL	7:0								RUD[7:0]	
		15:8								RUD[15:8]	
		23:16									RUD[23:16]
		31:24									RUD[31:24]
0x01FC	PEFRN	7:0								RUD[7:0]	
		15:8								RUD[15:8]	
		23:16									RUD[23:16]
		31:24									RUD[29:24]
0x0200 ... 0x026F	Reserved										
0x0270	RLPITR	7:0								RLPITR[7:0]	
		15:8								RLPITR[15:8]	
		23:16									
		31:24									
0x0274	RLPITI	7:0								RLPITI[7:0]	
		15:8								RLPITI[15:8]	
		23:16									RLPITI[23:16]
		31:24									
0x0278	TLPITR	7:0								TLPITR[7:0]	
		15:8								TLPITR[15:8]	
		23:16									
		31:24									
0x027C	TLPITI	7:0								TLPITI[7:0]	
		15:8								TLPITI[15:8]	
		23:16									TLPITI[23:16]
		31:24									

### 41.8.1 GMAC Network Control Register

**Name:** NCR  
**Offset:** 0x000  
**Reset:** 0x00000000  
**Property:** -

Bit	31	30	29	28	27	26	25	24
Access								
Reset								
Bit	23	22	21	20	19	18	17	16
Access					LPI	FNP	TXPBPF	ENPBPR
Reset					R/W	R/W	R/W	R/W
					0	0	0	0
Bit	15	14	13	12	11	10	9	8
Access	SRTSM			TXZQPF	TXPF	THALT	TSTART	BP
Reset	R/W			R/W	R/W	R/W	R/W	R/W
	0			0	0	0	0	0
Bit	7	6	5	4	3	2	1	0
Access	WESTAT	INCSTAT	CLRSTAT	MPE	TXEN	RXEN	LBL	
Reset	R/W	R/W	R/W	R/W	R/W	R/W	R/W	
	0	0	0	0	0	0	0	

#### Bit 19 – LPI Low Power Idle Enable

Writing a '1' to this bit will enable low power idle (LPI) transmission, immediately transmitted on txd and tx\_er.

#### Bit 18 – FNP Flush Next Packet

Writing a '1' to this bit will flush the next packet from the external RX DPRAM. Flushing the next packet will only take effect if the DMA is not currently writing a packet already stored in the DPRAM to memory.

#### Bit 17 – TXPBPF Transmit PFC Priority-based Pause Frame

Takes the values stored in the Transmit PFC Pause Register.

#### Bit 16 – ENPBPR Enable PFC Priority-based Pause Reception

Writing a '1' to this bit enables PFC Priority Based Pause Reception capabilities, enabling PFC negotiation and recognition of priority-based pause frames.

Value	Description
0	Normal operation
1	PFC Priority-based Pause frames are recognized

#### Bit 15 – SRTSM Store Receive Time Stamp to Memory

Writing a '1' to this bit causes the CRC of every received frame to be replaced with the value of the nanoseconds field of the 1588 timer that was captured as the receive frame passed the message time stamp point.

Value	Description
0	Normal operation
1	All received frames' CRC is replaced with a time stamp

**Bit 12 – TXZQPF** Transmit Zero Quantum Pause Frame

Writing a '1' to this bit causes a pause frame with zero quantum to be transmitted.  
Writing a '0' to this bit has no effect.

**Bit 11 – TXPF** Transmit Pause Frame

Writing one to this bit causes a pause frame to be transmitted.  
Writing a '0' to this bit has no effect.

**Bit 10 – THALT** Transmit Halt

Writing a '1' to this bit halts transmission as soon as any ongoing frame transmission ends.  
Writing a '0' to this bit has no effect.

**Bit 9 – TSTART** Start Transmission

Writing a '1' to this bit starts transmission.  
Writing a '0' to this bit has no effect.

**Bit 8 – BP** Back Pressure

In 10M or 100M half duplex mode, writing a '1' to this bit forces collisions on all received frames.

Value	Description
0	Frame collisions are not forced
1	Frame collisions are forced in 10M and 100M half duplex mode

**Bit 7 – WESTAT** Write Enable for Statistics Registers

Writing a '1' to this bit makes the statistics registers writable for functional test purposes.

Value	Description
0	Statistics Registers are write-protected
1	Statistics Registers are write-enabled

**Bit 6 – INCSTAT** Increment Statistics Registers

Writing a '1' to this bit increments all Statistics Registers by one for test purposes.  
Writing a '0' to this bit has no effect.  
This bit will always read '0'.

**Bit 5 – CLRSTAT** Clear Statistics Registers

Writing a '1' to this bit clears the Statistics Registers.  
Writing a '0' to this bit has no effect.  
This bit will always read '0'.

**Bit 4 – MPE** Management Port Enable

Writing a '1' to this bit enables the Management Port.  
Writing a '0' to this bit disables the Management Port, and forces MDIO to high impedance state and MDC to low impedance.

Value	Description
0	Management Port is disabled
1	Management Port is enabled

**Bit 3 – TXEN** Transmit Enable

Writing a '1' to this bit enables the GMAC transmitter to send data.  
Writing a '0' to this bit stops transmission immediately, the transmit pipeline and control registers is cleared, and the Transmit Queue Pointer Register will be set to point to the start of the transmit descriptor list.

Value	Description
0	Transmit is disabled
1	Transmit is enabled

**Bit 2 – RXEN** Receive Enable

Writing a '1' to this bit enables the GMAC to receive data.

Writing a '0' to this bit stops frame reception immediately, and the receive pipeline is cleared. The Receive Queue Pointer Register is not affected.

Value	Description
0	Receive is disabled
1	Receive is enabled

**Bit 1 – LBL** Loop Back Local

Writing '1' to this bit connects GTX to GRX, GTXEN to GRXDV, and forces full duplex mode.

GRXCK and GTXCK may malfunction as the GMAC is switched into and out of internal loop back. It is important that receive and transmit circuits have already been disabled when making the switch into and out of internal loop back.

Value	Description
0	Loop back local is disabled
1	Loop back local is enabled



## 41.8.2 GMAC Network Configuration Register

**Name:** NCFGR  
**Offset:** 0x004  
**Reset:** 0x00080000  
**Property:** R/W

Bit	31	30	29	28	27	26	25	24
		IRXER	RXBP	IPGSEN		IRXFCS	EFRHD	RXCOEN
Access		R/W	R/W	R/W		R/W	R/W	R/W
Reset		0	0	0		0	0	0
Bit	23	22	21	20	19	18	17	16
	DCPF	DBW[1:0]		CLK[2:0]			RFCFS	LFERD
Access	R/W	R/W	R/W	R/W	R/W	R/W	R/W	R/W
Reset	0	0	0	0	1	0	0	0
Bit	15	14	13	12	11	10	9	8
	RXBUFO[1:0]		PEN	RTY				MAXFS
Access	R/W	R/W	R/W	R/W				R/W
Reset	0	0	0	0				0
Bit	7	6	5	4	3	2	1	0
	UNIHEN	MTIHEN	NBC	CAF	JFRAME	DNVLAN	FD	SPD
Access	R/W	R/W	R/W	R/W	R/W	R/W	R/W	R/W
Reset	0	0	0	0	0	0	0	0

### Bit 30 – IRXER Ignore IPG GRXER

When this bit is written to '1', the Receive Error signal (GRXER) has no effect on the GMAC operation when Receive Data Valid signal (GRXDV) is low.

### Bit 29 – RXBP Receive Bad Preamble

When written to '1', frames with non-standard preamble are not rejected.

### Bit 28 – IPGSEN IP Stretch Enable

Writing a '1' to this bit allows the transmit IPG to increase above 96 bit times, depending on the previous frame length using the IPG Stretch Register.

### Bit 26 – IRXFCS Ignore RX FCS

For normal operation this bit must be written to zero.

When this bit is written to '1', frames with FCS/CRC errors will not be rejected. FCS error statistics will still be collected for frames with bad FCS, and FCS status will be recorded in the DMA descriptor of the frame.

### Bit 25 – EFRHD Enable Frames Received in half-duplex

Writing a '1' to this bit enables frames to be received in half-duplex mode while transmitting.

### Bit 24 – RXCOEN Receive Checksum Offload Enable

Writing a '1' to this bit enables the receive checksum engine, and frames with bad IP, TCP or UDP checksums are discarded.

**Bit 23 – DCPF** Disable Copy of Pause Frames

Writing a '1' to this bit prevents valid pause frames from being copied to memory. Pause frames are not copied regardless of the state of the Copy All Frames (CAF) bit, whether a hash match is found or whether a type ID match is identified.

If a destination address match is found, the pause frame will be copied to memory. Note that valid pause frames received will still increment pause statistics and pause the transmission of frames, as required.

**Bits 22:21 – DBW[1:0]** Data Bus Width

The default value for this register is 64 bits.

Value	Name	Description
0	DBW32	32-bit data bus width
1	DBW64	64-bit data bus width

**Bits 20:18 – CLK[2:0]** MDC Clock Division

These bits must be set according to MCK speed, and determine the number MCK will be divided by to generate Management Data Clock (MDC). For conformance with the 802.3 specification, MDC must not exceed 2.5MHz.

**Note:** MDC is only active during MDIO read and write operations.

Value	Name	Description
0	MCK8	MCK divided by 8 (MCK up to 20MHz)
1	MCK16	MCK divided by 16 (MCK up to 40MHz)
2	MCK32	MCK divided by 32 (MCK up to 80MHz)
3	MCK48	MCK divided by 48 (MCK up to 120MHz)
4	MCK64	MCK divided by 64 (MCK up to 160MHz)
5	MCK96	MCK divided by 96 (MCK up to 240MHz)

**Bit 17 – RFCS** Remove FCS

Writing this bit to '1' will cause received frames to be written to memory without their frame check sequence (last 4 bytes). The indicated frame length will be reduced by four bytes in this mode.

**Bit 16 – LFERD** Length Field Error Frame Discard

Writing a '1' to this bit discards frames with a measured length shorter than the extracted length field (as indicated by bytes 13 and 14 in a non-VLAN tagged frame). This only applies to frames with a length field less than 0x0600.

**Bits 15:14 – RXBUFO[1:0]** Receive Buffer Offset

These bits determine the number of bytes by which the received data is offset from the start of the receive buffer.

**Bit 13 – PEN** Pause Enable

When written to '1', transmission will pause if a non-zero 802.3 classic pause frame is received and PFC has not been negotiated.

**Bit 12 – RTY** Retry Test

This bit must be written to '0' for normal operation.

When writing a '1' to this bit, the back-off between collisions will always be one slot time. This setting helps testing the too many retries condition. This setting is also useful for pause frame tests by reducing the pause counter's decrement time from "512 bit times" to "every GRXCK cycle".

**Bit 8 – MAXFS** 1536 Maximum Frame Size

Writing a '1' to this bit increases the maximum accepted frame size to 1536 bytes in length. When written to '0', any frame above 1518 bytes in length is rejected.

**Bit 7 – UNIHEN** Unicast Hash Enable

When writing a '1' to this bit, unicast frames will be accepted when the 6-bit hash function of the destination address points to a bit that is set in the Hash Register.  
Writing a '0' to this bit disables unicast hashing.

**Bit 6 – MTIHEN** Multicast Hash Enable

When writing a '1' to this bit, multicast frames will be accepted when the 6-bit hash function of the destination address points to a bit that is set in the Hash Register.  
Writing a '0' to this bit disables multicast hashing.

**Bit 5 – NBC** No Broadcast

Writing a '1' to this bit will reject frames addressed to the broadcast address 0xFFFFFFFF (all '1').  
Writing a '0' to this bit allows broadcasting to 0xFFFFFFFF.

**Bit 4 – CAF** Copy All Frames

When writing a '1' to this bit, all valid frames will be accepted.

**Bit 3 – JFRAME** Jumbo Frame Size

Writing a '1' to this bit enables jumbo frames of up to 10240 bytes to be accepted. The default length is 10240 bytes.

**Bit 2 – DNVLAN** Discard Non-VLAN Frames

Writing a '1' to this bit allows only VLAN-tagged frames to pass to the address matching logic.  
Writing a '0' to this bit allows both VLAN\_tagged and untagged frames to pass to the address matching logic.

**Bit 1 – FD** Full Duplex

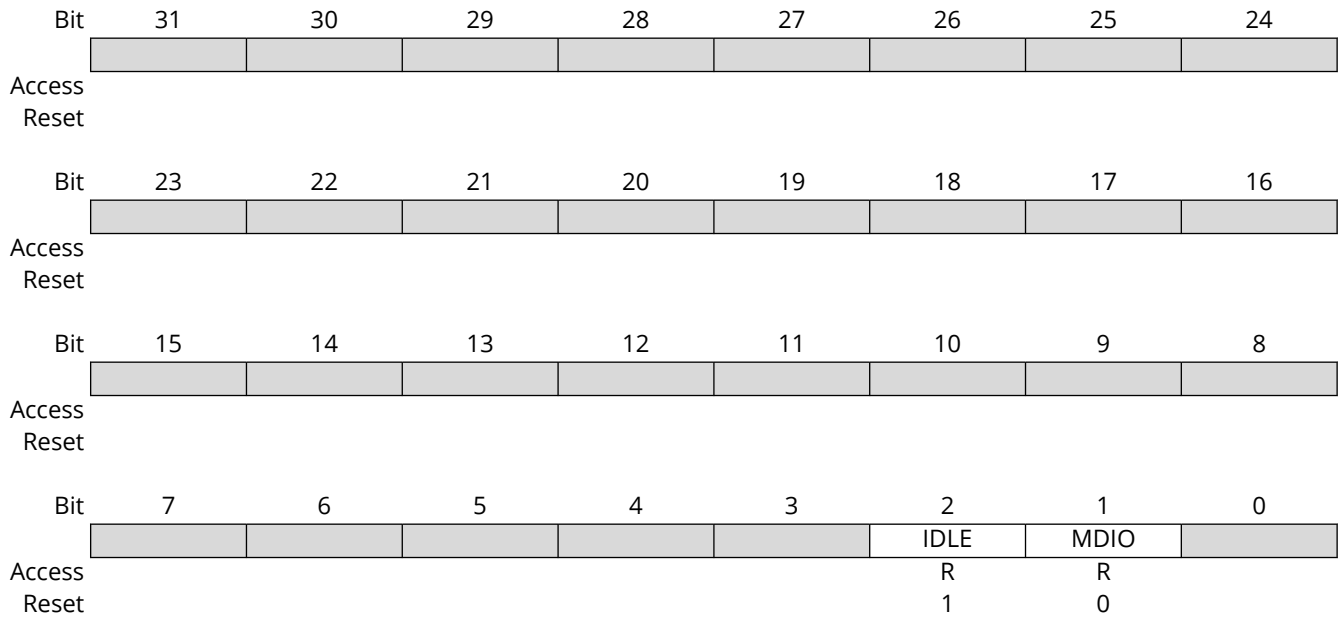
Writing a '1' enables full duplex operation, so the transmit block ignores the state of collision and carrier sense and allows receive while transmitting.  
Writing a '0' disables full duplex operation.

**Bit 0 – SPD** Speed

Writing a '1' selects 100Mbps operation.  
Writing a '0' to this bit selects 10Mbps operation.

### 41.8.3 GMAC Network Status Register

**Name:** NSR  
**Offset:** 0x008  
**Reset:** 0x00000004  
**Property:** -

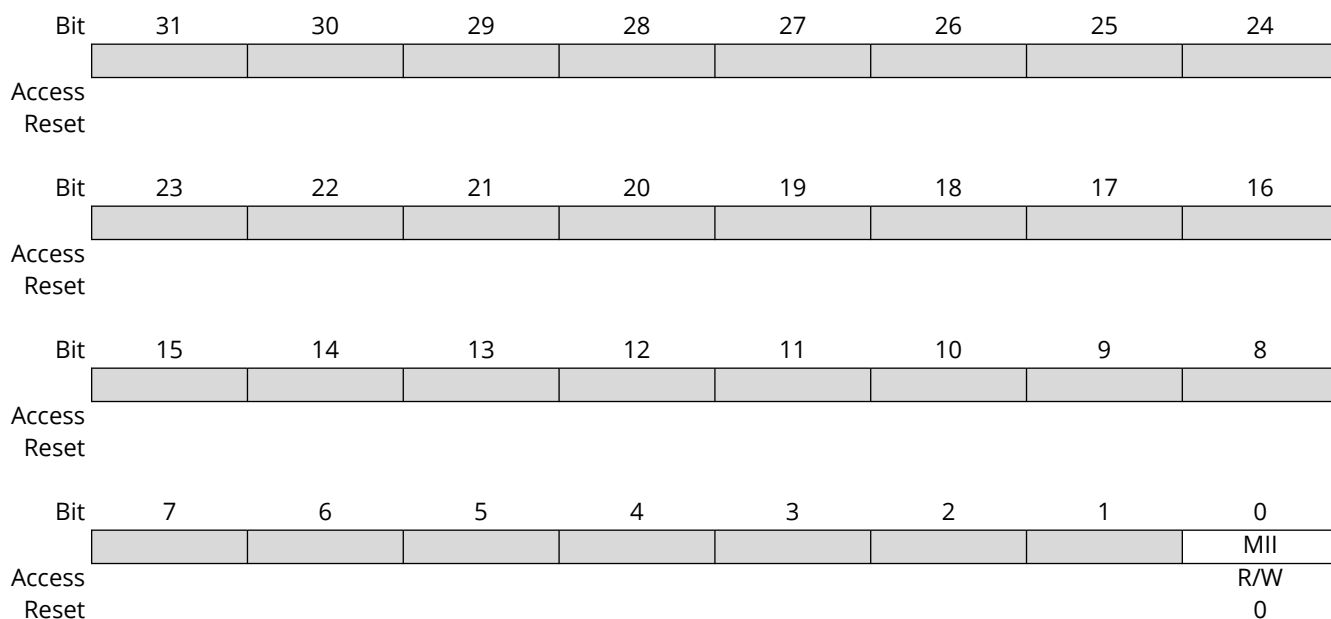


**Bit 2 - IDLE** PHY Management Logic Idle  
 The PHY management logic is idle (i.e., has completed).

**Bit 1 - MDIO** MDIO Input Status  
 Returns status of the MDIO pin.

#### 41.8.4 GMAC User Register

**Name:** UR  
**Offset:** 0x00C  
**Reset:** 0x00000000  
**Property:** -



#### Bit 0 - MII Reduced MII Mode

Value	Description
0	RMII mode is selected
1	MII mode is selected

### 41.8.5 GMAC DMA Configuration Register

**Name:** DCFGR  
**Offset:** 0x010  
**Reset:** 0x00020004  
**Property:** Read/Write

Bit	31	30	29	28	27	26	25	24
Access								DDRP
Reset								R/W
								0
Bit	23	22	21	20	19	18	17	16
Access	DRBS[7:0]							
Reset	R/W	R/W	R/W	R/W	R/W	R/W	R/W	R/W
	0	0	0	0	0	0	1	0
Bit	15	14	13	12	11	10	9	8
Access					TXCOEN	TXPBMS	RXBMS[1:0]	
Reset					R/W	R/W	R/W	R/W
					0	0	0	0
Bit	7	6	5	4	3	2	1	0
Access	ESPA	ESMA		FBLDO[4:0]				
Reset	R/W	R/W		R/W	R/W	R/W	R/W	R/W
	0	0		0	0	1	0	0

#### Bit 24 – DDRP DMA Discard Receive Packets

A write to this bit is ignored if the DMA is not configured in the packet buffer full store and forward mode.


Value	Description
0	Received packets are stored in the SRAM based packet buffer until next AHB buffer resource becomes available.
1	Receive packets from the receiver packet buffer memory are automatically discarded when no AHB resource is available.

#### Bits 23:16 – DRBS[7:0] DMA Receive Buffer Size

These bits defined by these bits determines the size of buffer to use in main AHB system memory when writing received data.

The value is defined in multiples of 64 bytes. For example:

- 0x02: 128 bytes
- 0x18: 1536 bytes (1 × max length frame/buffer)
- 0xA0: 10240 bytes (1 × 10K jumbo frame/buffer)

 Do not write 0x00 to this bit field.

Value	Description
0x00	Reserved
0x01–0xFF	1..255 x 64 byte buffer

**Bit 11 – TXCOEN** Transmitter Checksum Generation Offload Enable  
Transmitter IP, TCP and UDP checksum generation offload enable.

Value	Description
0	Frame data is unaffected.
1	The transmitter checksum generation engine calculates and substitutes checksums for transmit frames.

**Bit 10 – TXPBMS** Transmitter Packet Buffer Memory Size Select  
When written to zero, the amount of memory used for the transmit packet buffer is reduced by 50%. This reduces the amount of memory used by the GMAC.  
It is important to write this bit to '1' if the full configured physical memory is available. The value in parentheses represents the size that would result for the default maximum configured memory size of 4KBytes.

Value	Description
0	Top address bits not used. (2KByte used.)
1	Full configured addressable space (4KBytes) used.

**Bits 9:8 – RXBMS[1:0]** Receiver Packet Buffer Memory Size Select  
The default receive packet buffer size is FULL=RECEIVE\_BUFFER\_SIZE = 4KB. The table below shows how to configure this memory to FULL, HALF, QUARTER or EIGHTH of the default size.

Value	Name	Description
0	EIGHTH	RECEIVE_BUFFER_SIZE = 4KB/8 Memory Size
1	QUARTER	RECEIVE_BUFFER_SIZE = 4KB/4 Memory Size
2	HALF	RECEIVE_BUFFER_SIZE = 4KB/2 Memory Size
3	FULL	RECEIVE_BUFFER_SIZE = 4KB Memory Size

**Bit 7 – ESPA** Endian Swap Mode Enable for Packet Data Accesses

Value	Description
0	Little endian mode for AHB transfers selected.
1	Big endian mode for AHB transfers selected.

**Bit 6 – ESMA** Endian Swap Mode Enable for Management Descriptor Accesses

Value	Description
0	Little endian mode for AHB transfers selected.
1	Big endian mode for AHB transfers selected.

**Bits 4:0 – FBLDO[4:0]** Fixed Burst Length for DMA Data Operations  
Selects the burst length to attempt to use on the AHB when transferring frame data. Not used for DMA management operations and only used where space and data size allow. Otherwise SINGLE type AHB transfers are used.  
One-hot priority encoding enforced automatically on register writes as follows. 'x' represents don't care.

Value	Name	Description
0	-	Reserved
1	SINGLE	00001: Always use SINGLE AHB bursts
2	-	Reserved
4	INCR4	001xx: Attempt to use INCR4 AHB bursts (Default)
8	INCR8	01xxx: Attempt to use INCR8 AHB bursts
16	INCR16	1xxxx: Attempt to use INCR16 AHB bursts

## 41.8.6 GMAC Transmit Status Register

**Name:** TSR  
**Offset:** 0x014  
**Reset:** 0x00000000  
**Property:** -

Bit	31	30	29	28	27	26	25	24
Access								
Reset								
Bit	23	22	21	20	19	18	17	16
Access								
Reset								
Bit	15	14	13	12	11	10	9	8
Access								HRESP
Reset								R/W 0
Bit	7	6	5	4	3	2	1	0
Access		UND	TXCOMP	TFC	TXGO	RLE	COL	UBR
Reset		R/W 0	R/W 0	R/W 0	R/W 0	R/W 0	R/W 0	R/W 0

**Bit 8 – HRESP** HRESP Not OK  
Set when the DMA block sees HRESP not OK.  
This bit is cleared by writing a '1' to it.

**Bit 6 – UND** Transmit Underrun  
This bit is set if the transmitter was forced to terminate the transmission of a frame due to further data being unavailable.  
This bit is also set if a transmitter status write back has not completed when another status write back is attempted.  
When using the DMA interface configured for internal FIFO mode, this bit is also set when the transmit DMA has written the SOP data into the FIFO and either the AHB bus was not granted in time for further data, or an AHB not OK response was returned, or a used bit was read.  
This bit is cleared by writing a '1' to it.

**Bit 5 – TXCOMP** Transmit Complete  
Set when a frame has been transmitted.  
This bit is cleared by writing a '1' to it.

**Bit 4 – TFC** Transmit Frame Corruption Due to AHB Error  
This bit is set when an error occurs during reading transmit frame from the AHB. Error causes include HRESP errors and buffers exhausted mid frame. (If the buffers run out during transmission of a frame then transmission stops, FCS shall be bad and GTXER asserted).  
In DMA packet buffer mode, this bit is also set if a single frame is too large for the configured packet buffer memory size.  
This bit is cleared by writing a '1' to it.



**Bit 3 – TXGO** Transmit Go

This bit is '1' when transmit is active. When using the DMA interface this bit represents the TXGO variable as specified in the transmit buffer description.

**Bit 2 – RLE** Retry Limit Exceeded

This bit is cleared by writing a '1' to it.

**Bit 1 – COL** Collision Occurred

When operating in 10/100Mbps mode, this bit is set by the assertion of either a collision or a late collision.

This bit is cleared by writing a '1' to it.

**Bit 0 – UBR** Used Bit Read

This bit is set when a transmit buffer descriptor is read with its used bit set.

This bit is cleared by writing a '1' to it.

### 41.8.7 GMAC Receive Buffer Queue Base Address Register

**Name:** RBQB  
**Offset:** 0x018  
**Reset:** 0x00000000  
**Property:** Read/Write

This register holds the start address of the receive buffer queue (receive buffers descriptor list). The receive buffer queue base address must be initialized before receive is enabled through bit 2 of the Network Control Register. Once reception is enabled, any write to the Receive Buffer Queue Base Address Register is ignored. Reading this register returns the location of the descriptor currently being accessed. This value increments as buffers are used. Software should not use this register for determining where to remove received frames from the queue as it constantly changes as new frames are received. Software should instead work its way through the buffer descriptor queue checking the “used” bits.

In terms of AMBA AHB operation, the descriptors are read from memory using a single 32-bit AHB access. The descriptors should be aligned at 32-bit boundaries and the descriptors are written to using two individual non sequential accesses.

Bit	31	30	29	28	27	26	25	24	
	ADDR[29:22]								
Access	R/W	R/W	R/W	R/W	R/W	R/W	R/W	R/W	
Reset	0	0	0	0	0	0	0	0	
Bit	23	22	21	20	19	18	17	16	
	ADDR[21:14]								
Access	R/W	R/W	R/W	R/W	R/W	R/W	R/W	R/W	
Reset	0	0	0	0	0	0	0	0	
Bit	15	14	13	12	11	10	9	8	
	ADDR[13:6]								
Access	R/W	R/W	R/W	R/W	R/W	R/W	R/W	R/W	
Reset	0	0	0	0	0	0	0	0	
Bit	7	6	5	4	3	2	1	0	
	ADDR[5:0]								
Access	R/W	R/W	R/W	R/W	R/W	R/W			
Reset	0	0	0	0	0	0			

**Bits 31:2 – ADDR[29:0]** Receive Buffer Queue Base Address  
 Written with the address of the start of the receive queue.

### 41.8.8 GMAC Transmit Buffer Queue Base Address Register

**Name:** TBQB  
**Offset:** 0x01C  
**Reset:** 0x00000000  
**Property:** -

This register holds the start address of the transmit buffer queue (transmit buffers descriptor list). The Transmit Buffer Queue Base Address Register must be initialized before transmit is started through bit 9 of the Network Control Register. Once transmission has started, any write to the Transmit Buffer Queue Base Address Register is illegal and therefore ignored.

Note that due to clock boundary synchronization, it takes a maximum of four MCK cycles from the writing of the transmit start bit before the transmitter is active. Writing to the Transmit Buffer Queue Base Address Register during this time may produce unpredictable results.

Reading this register returns the location of the descriptor currently being accessed. Since the DMA handles two frames at once, this may not necessarily be pointing to the current frame being transmitted.

In terms of AMBA AHB operation, the descriptors are written to memory using a single 32-bit AHB access. The descriptors should be aligned at 32-bit boundaries and the descriptors are read from memory using two individual non sequential accesses.

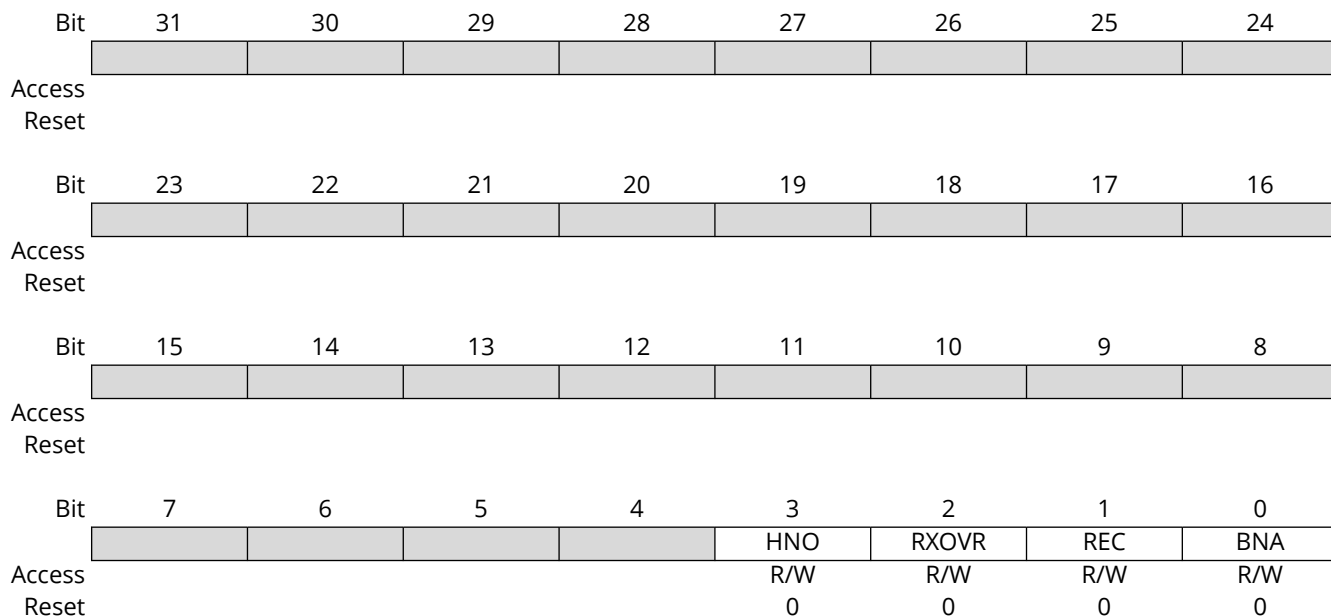
Bit	31	30	29	28	27	26	25	24	
	ADDR[29:22]								
Access	R/W	R/W	R/W	R/W	R/W	R/W	R/W	R/W	
Reset	0	0	0	0	0	0	0	0	
Bit	23	22	21	20	19	18	17	16	
	ADDR[21:14]								
Access	R/W	R/W	R/W	R/W	R/W	R/W	R/W	R/W	
Reset	0	0	0	0	0	0	0	0	
Bit	15	14	13	12	11	10	9	8	
	ADDR[13:6]								
Access	R/W	R/W	R/W	R/W	R/W	R/W	R/W	R/W	
Reset	0	0	0	0	0	0	0	0	
Bit	7	6	5	4	3	2	1	0	
	ADDR[5:0]								
Access	R/W	R/W	R/W	R/W	R/W	R/W			
Reset	0	0	0	0	0	0			

**Bits 31:2 – ADDR[29:0]** Transmit Buffer Queue Base Address  
 Written with the address of the start of the transmit queue.

### 41.8.9 GMAC Receive Status Register

**Name:** RSR  
**Offset:** 0x020  
**Reset:** 0x00000000  
**Property:** -

This register, when read, provides receive status details. Once read, individual bits may be cleared by writing a '1' to them. It is not possible to set a bit to '1' by writing to this register.



**Bit 3 - HNO** HRESP Not OK

This bit is set when the DMA block sees HRESP not OK.  
This bit is cleared by writing a '1' to it.

**Bit 2 - RXOVR** Receive Overrun

This bit is set if the receive status was not taken at the end of the frame. The buffer will be recovered if an overrun occurs.  
This bit is cleared by writing a '1' to it.

**Bit 1 - REC** Frame Received

This bit is set to when one or more frames have been received and placed in memory.  
This bit is cleared by writing a '1' to it.

**Bit 0 - BNA** Buffer Not Available

When this bit is set, an attempt was made to get a new buffer and the pointer indicated that it was owned by the processor. The DMA will re-read the pointer each time an end of frame is received until a valid pointer is found. This bit is set following each descriptor read attempt that fails, even if consecutive pointers are unsuccessful and software has in the mean time cleared the status flag.  
This bit is cleared by writing a '1' to it.

## 41.8.10 GMAC Interrupt Status Register

**Name:** ISR  
**Offset:** 0x024  
**Reset:** 0x00000000  
**Property:** -

This register indicates the source of the interrupt. An interrupt source must be enabled in the mask register first so the corresponding bits of this register will be set and the GMAC interrupt signal will be asserted in the system.

Bit	31	30	29	28	27	26	25	24
			TSUCMP	WOL	RXLPISBC	SRI	PDRSFT	PDRQFT
Access			W	R	R	R	R	R
Reset			0	0	0	0	0	0

Bit	23	22	21	20	19	18	17	16
	PDRSFR	PDRQFR	SFT	DRQFT	SFR	DRQFR		
Access	R	R	R	R	R	R		
Reset	0	0	0	0	0	0		

Bit	15	14	13	12	11	10	9	8
		PFTR	PTZ	PFNZ	HRESP	ROVR		
Access		R	R	R	R	R		
Reset		0	0	0	0	0		

Bit	7	6	5	4	3	2	1	0
	TCOMP	TFC	RLEX	TUR	TXUBR	RXUBR	RCOMP	MFS
Access	R	R	R	R	R	R	R	R
Reset	0	0	0	0	0	0	0	0

**Bit 29 – TSUCMP** TSU Timer Comparison  
Indicates TSU times count and comparison value are equal.

**Bit 28 – WOL** Wake On LAN  
WOL interrupt. Indicates a WOL message has been received.

**Bit 27 – RXLPISBC** Receive LPI Indication Status Bit Change  
Receive LPI indication status bit change.  
Cleared on read.

**Bit 26 – SRI** TSU Seconds Register Increment  
Indicates the register has incremented.  
Cleared on read.

**Bit 25 – PDRSFT** PDelay Response Frame Transmitted  
Indicates a PTP pdelay\_resp frame has been transmitted.  
Cleared on read.

**Bit 24 – PDRQFT** PDelay Request Frame Transmitted  
Indicates a PTP pdelay\_req frame has been transmitted.  
Cleared on read.

- Bit 23 – PDRSFR** PDelay Response Frame Received  
Indicates a PTP pdelay\_resp frame has been received.  
Cleared on read.
- Bit 22 – PDRQFR** PDelay Request Frame Received  
Indicates a PTP pdelay\_req frame has been received.  
Cleared on read.
- Bit 21 – SFT** PTP Sync Frame Transmitted  
Indicates a PTP sync frame has been transmitted.  
Cleared on read.
- Bit 20 – DRQFT** PTP Delay Request Frame Transmitted  
Indicates a PTP delay\_req frame has been transmitted.  
Cleared on read.
- Bit 19 – SFR** PTP Sync Frame Received  
Indicates a PTP sync frame has been received.  
Cleared on read.
- Bit 18 – DRQFR** PTP Delay Request Frame Received  
Indicates a PTP delay\_req frame has been received.  
Cleared on read.
- Bit 14 – PFTR** Pause Frame Transmitted  
Indicates a pause frame has been successfully transmitted after being initiated from the Network Control Register.  
Cleared on read.
- Bit 13 – PTZ** Pause Time Zero  
Set when either the Pause Time Register at address 0x38 decrements to zero, or when a valid pause frame is received with a zero pause quantum field.  
Cleared on read.
- Bit 12 – PFNZ** Pause Frame with Non-zero Pause Quantum Received  
Indicates a valid pause has been received that has a non-zero pause quantum field.  
Cleared on read.
- Bit 11 – HRESP** HRESP Not OK  
Set when the DMA block sees HRESP not OK.  
Cleared on read.
- Bit 10 – ROVR** Receive Overrun  
Set when the receive overrun status bit is set.  
Cleared on read.
- Bit 7 – TCOMP** Transmit Complete  
Set when a frame has been transmitted.  
Cleared on read.
- Bit 6 – TFC** Transmit Frame Corruption Due to AHB Error  
Transmit frame corruption due to AHB error. Set if an error occurs during reading a transmit frame from the AHB, including HRESP errors and buffers exhausted mid frame.

**Bit 5 – RLEX** Retry Limit Exceeded

Retry Limit Exceeded Transmit error.  
Cleared on read.

**Bit 4 – TUR** Transmit Underrun

This interrupt is set if the transmitter was forced to terminate an ongoing frame transmission due to further data being unavailable.

This interrupt is also set if a transmitter status write back has not completed when another status write back is attempted.

This interrupt is also set when the transmit DMA has written the SOP data into the FIFO and either the AHB bus was not granted in time for further data, or because an AHB not OK response was returned, or because the used bit was read.

**Bit 3 – TXUBR** TX Used Bit Read

Set when a transmit buffer descriptor is read with its used bit set.  
Cleared on read.

**Bit 2 – RXUBR** RX Used Bit Read

Set when a receive buffer descriptor is read with its used bit set.  
Cleared on read.

**Bit 1 – RCOMP** Receive Complete

A frame has been stored in memory.  
Cleared on read.

**Bit 0 – MFS** Management Frame Sent

The PHY Maintenance Register has completed its operation.  
Cleared on read.

### 41.8.11 GMAC Interrupt Enable Register

**Name:** IER  
**Offset:** 0x028  
**Reset:** -  
**Property:** Write-only

This register is write-only and will always return zero.

The following values are valid for all listed bit names of this register:

0: No effect.

1: Enables the corresponding interrupt.

Bit	31	30	29	28	27	26	25	24
			TSUCMP	WOL	RXLPISBC	SRI	PDRSFT	PDRQFT
Access			W	W	W	W	W	W
Reset			-	-	0	-	-	-
Bit	23	22	21	20	19	18	17	16
	PDRSFR	PDRQFR	SFT	DRQFT	SFR	DRQFR		
Access	W	W	W	W	W	W		
Reset	-	-	-	-	-	-		
Bit	15	14	13	12	11	10	9	8
	EXINT	PFTR	PTZ	PFNZ	HRESP	ROVR		
Access	W	W	W	W	W	W		
Reset	-	-	-	-	-	-		
Bit	7	6	5	4	3	2	1	0
	TCOMP	TFC	RLEX	TUR	TXUBR	RXUBR	RCOMP	MFS
Access	W	W	W	W	W	W	W	W
Reset	-	-	-	-	-	-	-	-

**Bit 29 – TSUCMP** TSU Timer Comparison

**Bit 28 – WOL** Wake On LAN

**Bit 27 – RXLPISBC** Receive LPI Indication

**Bit 26 – SRI** TSU Seconds Register Increment

**Bit 25 – PDRSFT** PDelay Response Frame Transmitted

**Bit 24 – PDRQFT** PDelay Request Frame Transmitted

**Bit 23 – PDRSFR** PDelay Response Frame Received

**Bit 22 – PDRQFR** PDelay Request Frame Received

**Bit 21 – SFT** PTP Sync Frame Transmitted

**Bit 20 – DRQFT** PTP Delay Request Frame Transmitted

**Bit 19 – SFR** PTP Sync Frame Received



- Bit 18 – DRQFR** PTP Delay Request Frame Received
- Bit 15 – EXINT** External Interrupt
- Bit 14 – PFTR** Pause Frame Transmitted
- Bit 13 – PTZ** Pause Time Zero
- Bit 12 – PFNZ** Pause Frame with Non-zero Pause Quantum Received
- Bit 11 – HRESP** HRESP Not OK
- Bit 10 – ROVR** Receive Overrun
- Bit 7 – TCOMP** Transmit Complete
- Bit 6 – TFC** Transmit Frame Corruption Due to AHB Error
- Bit 5 – RLEX** Retry Limit Exceeded or Late Collision
- Bit 4 – TUR** Transmit Underrun
- Bit 3 – TXUBR** TX Used Bit Read
- Bit 2 – RXUBR** RX Used Bit Read
- Bit 1 – RCOMP** Receive Complete
- Bit 0 – MFS** Management Frame Sent

## 41.8.12 GMAC Interrupt Disable Register

**Name:** IDR  
**Offset:** 0x02C  
**Reset:** -  
**Property:** Write-only

This register is write-only and will always return zero.

The following values are valid for all listed bit names of this register:

0: No effect.

1: Disables the corresponding interrupt.

Bit	31	30	29	28	27	26	25	24
			TSUCMP	WOL	RXLPISBC	SRI	PDRSFT	PDRQFT
Access			W	W	R	W	W	W
Reset			-	-	-	-	-	-
Bit	23	22	21	20	19	18	17	16
	PDRSFR	PDRQFR	SFT	DRQFT	SFR	DRQFR		
Access	W	W	W	W	W	W		
Reset	-	-	-	-	-	-		
Bit	15	14	13	12	11	10	9	8
	EXINT	PFTR	PTZ	PFNZ	HRESP	ROVR		
Access	W	W	W	W	W	W		
Reset	-	-	-	-	-	-		
Bit	7	6	5	4	3	2	1	0
	TCOMP	TFC	RLEX	TUR	TXUBR	RXUBR	RCOMP	MFS
Access	W	W	W	W	W	W	W	W
Reset	-	-	-	-	-	-	-	-

**Bit 29 – TSUCMP** TSU Timer Comparison

**Bit 28 – WOL** Wake On LAN

**Bit 27 – RXLPISBC** RX LPI Indication

**Bit 26 – SRI** TSU Seconds Register Increment

**Bit 25 – PDRSFT** PDelay Response Frame Transmitted

**Bit 24 – PDRQFT** PDelay Request Frame Transmitted

**Bit 23 – PDRSFR** PDelay Response Frame Received

**Bit 22 – PDRQFR** PDelay Request Frame Received

**Bit 21 – SFT** PTP Sync Frame Transmitted

**Bit 20 – DRQFT** PTP Delay Request Frame Transmitted

**Bit 19 – SFR** PTP Sync Frame Received

- Bit 18 – DRQFR** PTP Delay Request Frame Received
- Bit 15 – EXINT** External Interrupt
- Bit 14 – PFTR** Pause Frame Transmitted
- Bit 13 – PTZ** Pause Time Zero
- Bit 12 – PFNZ** Pause Frame with Non-zero Pause Quantum Received
- Bit 11 – HRESP** HRESP Not OK
- Bit 10 – ROVR** Receive Overrun
- Bit 7 – TCOMP** Transmit Complete
- Bit 6 – TFC** Transmit Frame Corruption Due to AHB Error
- Bit 5 – RLEX** Retry Limit Exceeded or Late Collision
- Bit 4 – TUR** Transmit Underrun
- Bit 3 – TXUBR** TX Used Bit Read
- Bit 2 – RXUBR** RX Used Bit Read
- Bit 1 – RCOMP** Receive Complete
- Bit 0 – MFS** Management Frame Sent

### 41.8.13 GMAC Interrupt Mask Register

**Name:** IMR  
**Offset:** 0x030  
**Reset:** 0x03FFFFFF  
**Property:** -

This register is a read-only register indicating which interrupts are masked. All bits are set at Reset and can be reset individually by writing to the Interrupt Enable Register (IER), or set individually by writing to the Interrupt Disable Register (IDR).

For test purposes there is a write-only function to this register that allows the bits in the Interrupt Status Register to be set or cleared, regardless of the state of the mask register. A write to this register directly affects the state of the corresponding bit in the Interrupt Status Register, causing an interrupt to be generated if a 1 is written.

The following values are valid for all listed bit names of this register when read:

0: The corresponding interrupt is enabled.

1: The corresponding interrupt is not enabled.

Bit	31	30	29	28	27	26	25	24
			TSUCMP	WOL	RXLPISBC	SRI	PDRSFT	PDRQFT
Access			W	R	R	R	R	R
Reset			1	1	1	0	1	1
Bit	23	22	21	20	19	18	17	16
	PDRSFR	PDRQFR	SFT	DRQFT	SFR	DRQFR		
Access	R	R	R	R	R	R		
Reset	1	1	1	1	1	1		
Bit	15	14	13	12	11	10	9	8
	EXINT	PFTR	PTZ	PFNZ	HRESP	ROVR		
Access	R	R	R	R	R	R		
Reset	1	1	1	1	1	1		
Bit	7	6	5	4	3	2	1	0
	TCOMP	TFC	RLEX	TUR	TXUBR	RXUBR	RCOMP	MFS
Access	R	R	R	R	R	R	R	R
Reset	1	1	1	1	1	1	1	1

**Bit 29 – TSUCMP** TSU Timer Comparison  
Indicates TSU times count and comparison value are equal.

**Bit 28 – WOL** Wake On LAN  
WOL interrupt. Indicates a WOL message has been received.

**Bit 27 – RXLPISBC** RXLPI Indication

**Bit 26 – SRI** TSU Seconds Register Increment  
Indicates the register has incremented.  
Cleared on read.

**Bit 25 – PDRSFT** PDelay Response Frame Transmitted

- Bit 24 – PDRQFT** PDelay Request Frame Transmitted
- Bit 23 – PDRSFR** PDelay Response Frame Received
- Bit 22 – PDRQFR** PDelay Request Frame Received
- Bit 21 – SFT** PTP Sync Frame Transmitted
- Bit 20 – DRQFT** PTP Delay Request Frame Transmitted
- Bit 19 – SFR** PTP Sync Frame Received
- Bit 18 – DRQFR** PTP Delay Request Frame Received
- Bit 15 – EXINT** External Interrupt
- Bit 14 – PFTR** Pause Frame Transmitted
- Bit 13 – PTZ** Pause Time Zero
- Bit 12 – PFNZ** Pause Frame with Non-zero Pause Quantum Received
- Bit 11 – HRESP** HRESP Not OK
- Bit 10 – ROVR** Receive Overrun
- Bit 7 – TCOMP** Transmit Complete
- Bit 6 – TFC** Transmit Frame Corruption Due to AHB Error
- Bit 5 – RLEX** Retry Limit Exceeded
- Bit 4 – TUR** Transmit Underrun
- Bit 3 – TXUBR** TX Used Bit Read
- Bit 2 – RXUBR** RX Used Bit Read
- Bit 1 – RCOMP** Receive Complete
- Bit 0 – MFS** Management Frame Sent

#### 41.8.14 GMAC PHY Maintenance Register

**Name:** MAN  
**Offset:** 0x034  
**Reset:** 0x00000000  
**Property:** Read/Write

This register is a shift register. Writing to it starts a shift operation which is signaled completed when bit 2 is set in the Network Status Register (NSR). It takes about 2000 MCK cycles to complete, when MDC is set for MCK divide by 32 in the Network Configuration Register. An interrupt is generated upon completion.

During this time, the MSB of the register is output on the MDIO pin and the LSB updated from the MDIO pin with each MDC cycle. This causes transmission of a PHY management frame on MDIO. Refer also to section 22.2.4.5 of the IEEE 802.3 standard.

Reading during the shift operation returns the current contents of the shift register. At the end of management operation, the bits will have shifted back to their original locations. For a read operation, the data bits are updated with data read from the PHY. It is important to write the correct values to the register to ensure a valid PHY management frame is produced.

The MDIO interface can read IEEE 802.3 clause 45 PHYs, as well as clause 22 PHYs. To read clause 45 PHYs, bit 30 should be written with a '0' rather than a '1'. To write clause 45 PHYs, bits 31:28 should be written as 0x1:

PHY	Access	Bit Value			
		WZO	CLTTO	OP[1]	OP[0]
Clause 22	Read	0	1	1	0
	Write	0	1	0	1
Clause 45	Read	0	0	1	1
	Write	0	0	0	1
	Read + Address	0	0	1	0

For a description of MDC generation, see also the 'GMAC Network Configuration Register' (NCR) description.

Bit	31	30	29	28	27	26	25	24
	WZO		CLTTO	OP[1:0]		PHYA[4:1]		
Access	R/W	R/W	R/W	R/W	R/W	R/W	R/W	R/W
Reset	0	0	0	0	0	0	0	0
Bit	23	22	21	20	19	18	17	16
	PHYA[0]	REGA[4:0]				WTN[1:0]		
Access	R/W	R/W	R/W	R/W	R/W	R/W	R/W	R/W
Reset	0	0	0	0	0	0	0	0
Bit	15	14	13	12	11	10	9	8
	DATA[15:8]							
Access	R/W	R/W	R/W	R/W	R/W	R/W	R/W	R/W
Reset	0	0	0	0	0	0	0	0
Bit	7	6	5	4	3	2	1	0
	DATA[7:0]							
Access	R/W	R/W	R/W	R/W	R/W	R/W	R/W	R/W
Reset	0	0	0	0	0	0	0	0

**Bit 31 - WZO** Write ZERO

Must be written to '0'.

Value	Description
0	Mandatory
1	Reserved

**Bit 30 - CLTTO** Clause 22 Operation

Value	Description
0	Clause 45 operation
1	Clause 22 operation

**Bits 29:28 - OP[1:0]** Operation

Value	Description
01	Write
10	Read
Other	Reserved

**Bits 27:23 - PHYA[4:0]** PHY Address

**Bits 22:18 - REGA[4:0]** Register Address

Specifies the register in the PHY to access.

**Bits 17:16 - WTN[1:0]** Write Ten

Must be written to '10'.

Value	Description
10	Mandatory
Other	Reserved

**Bits 15:0 - DATA[15:0]** PHY Data

For a write operation, this field is written with the data to be written to the PHY.  
After a read operation, this field contains the data read from the PHY.

### 41.8.15 GMAC Receive Pause Quantum Register

**Name:** RPQ  
**Offset:** 0x038  
**Reset:** 0x00000000  
**Property:** -

Bit	31	30	29	28	27	26	25	24
Access								
Reset								
Bit	23	22	21	20	19	18	17	16
Access								
Reset								
Bit	15	14	13	12	11	10	9	8
Access	RPQ[15:8]							
Reset	0	0	0	0	0	0	0	0
Bit	7	6	5	4	3	2	1	0
Access	RPQ[7:0]							
Reset	0	0	0	0	0	0	0	0

#### Bits 15:0 – RPQ[15:0] Received Pause Quantum

Stores the current value of the Receive Pause Quantum Register which is decremented every 512 bit times.



### 41.8.16 GMAC Transmit Pause Quantum Register

**Name:** TPQ  
**Offset:** 0x03C  
**Reset:** 0x0000FFFF  
**Property:** -

Bit	31	30	29	28	27	26	25	24
Access								
Reset								
Bit	23	22	21	20	19	18	17	16
Access								
Reset								
Bit	15	14	13	12	11	10	9	8
Access	TPQ[15:8]							
Reset	R/W	R/W	R/W	R/W	R/W	R/W	R/W	R/W
Reset	1	1	1	1	1	1	1	1
Bit	7	6	5	4	3	2	1	0
Access	TPQ[7:0]							
Reset	R/W	R/W	R/W	R/W	R/W	R/W	R/W	R/W
Reset	1	1	1	1	1	1	1	1

#### Bits 15:0 – TPQ[15:0] Transmit Pause Quantum

Written with the pause quantum value for pause frame transmission.

### 41.8.17 GMAC TX Partial Store and Forward Register

**Name:** TPSF  
**Offset:** 0x040  
**Reset:** 0x00000FFF  
**Property:** -

Bit	31	30	29	28	27	26	25	24
	ENTXP							
Access	R/W							
Reset	0							
Bit	23	22	21	20	19	18	17	16
Access								
Reset								
Bit	15	14	13	12	11	10	9	8
							TPB1ADR[9:8]	
Access							R/W	R/W
Reset							1	1
Bit	7	6	5	4	3	2	1	0
	TPB1ADR[7:0]							
Access	R/W	R/W	R/W	R/W	R/W	R/W	R/W	R/W
Reset	1	1	1	1	1	1	1	1

**Bit 31 – ENTXP** Enable TX Partial Store and Forward Operation

**Bits 9:0 – TPB1ADR[9:0]** Transmit Partial Store and Forward Address Watermark value.

### 41.8.18 GMAC RX Partial Store and Forward Register

**Name:** RPSF  
**Offset:** 0x044  
**Reset:** 0x00000FFF  
**Property:** -

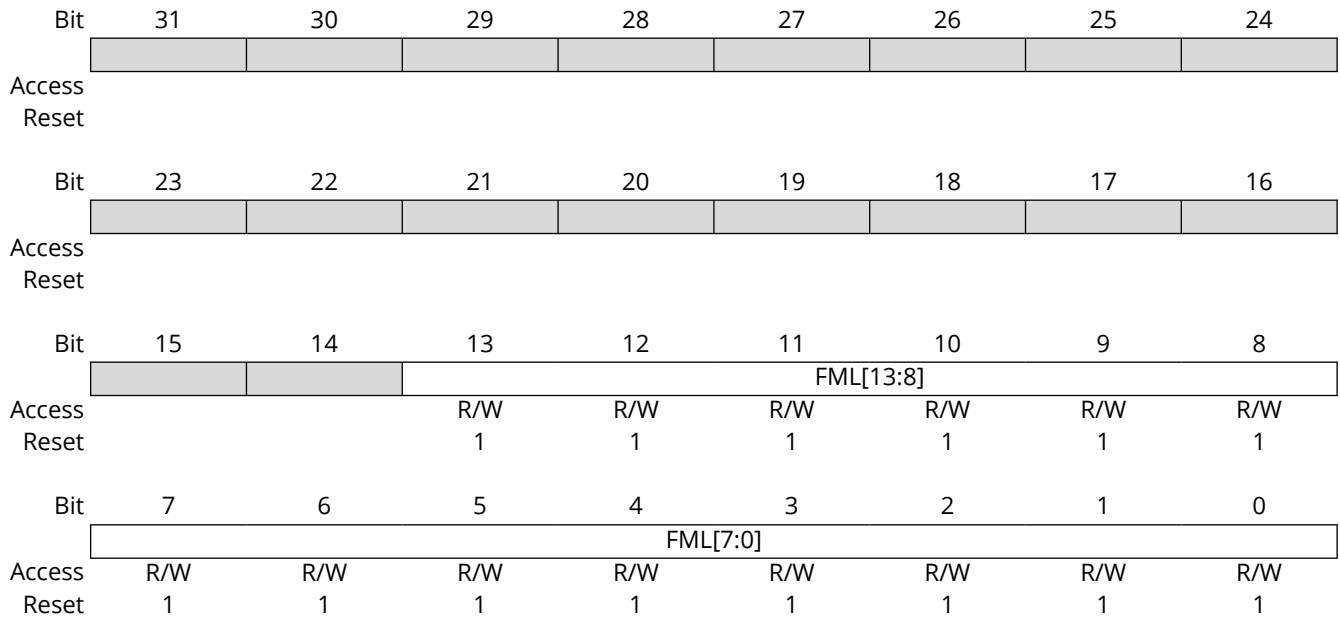
Bit	31	30	29	28	27	26	25	24
	ENRXP							
Access	R							
Reset	0							
Bit	23	22	21	20	19	18	17	16
Access								
Reset								
Bit	15	14	13	12	11	10	9	8
							RPB1ADR[9:8]	
Access							R/W	R/W
Reset							1	1
Bit	7	6	5	4	3	2	1	0
	RPB1ADR[7:0]							
Access	R/W	R/W	R/W	R/W	R/W	R/W	R/W	R/W
Reset	1	1	1	1	1	1	1	1

**Bit 31 – ENRXP** Enable RX Partial Store and Forward Operation

**Bits 9:0 – RPB1ADR[9:0]** Receive Partial Store and Forward Address Watermark value. Reset = 1.

### 41.8.19 GMAC RX Jumbo Frame Max Length Register

**Name:** RJFML  
**Offset:** 0x048  
**Reset:** 0x00003FFF  
**Property:** -



**Bits 13:0 – FML[13:0]** Frame Max Length  
 Rx jumbo frame maximum length.

## 41.8.20 GMAC Hash Register Bottom

**Name:** HRB  
**Offset:** 0x080  
**Reset:** 0x00000000  
**Property:** Read/Write

The unicast hash enable (UNIHEN) and the multicast hash enable (MITIHEN) bits in the Network Configuration Register (NCFGR) enable the reception of hash matched frames.

Bit	31	30	29	28	27	26	25	24
	ADDR[31:24]							
Access	R/W	R/W	R/W	R/W	R/W	R/W	R/W	R/W
Reset	0	0	0	0	0	0	0	0
Bit	23	22	21	20	19	18	17	16
	ADDR[23:16]							
Access	R/W	R/W	R/W	R/W	R/W	R/W	R/W	R/W
Reset	0	0	0	0	0	0	0	0
Bit	15	14	13	12	11	10	9	8
	ADDR[15:8]							
Access	R/W	R/W	R/W	R/W	R/W	R/W	R/W	R/W
Reset	0	0	0	0	0	0	0	0
Bit	7	6	5	4	3	2	1	0
	ADDR[7:0]							
Access	R/W	R/W	R/W	R/W	R/W	R/W	R/W	R/W
Reset	0	0	0	0	0	0	0	0

### Bits 31:0 – ADDR[31:0] Hash Address

The first 32 bits of the Hash Address Register.

## 41.8.21 GMAC Hash Register Top

**Name:** HRT  
**Offset:** 0x084  
**Reset:** 0x00000000  
**Property:** Read/Write

The Unicast Hash Enable (UNIHEN) and the Multicast Hash Enable (MITIHEN) bits in the Network Configuration Register (NCFGR) enable the reception of hash matched frames.

Bit	31	30	29	28	27	26	25	24
	ADDR[31:24]							
Access	R/W	R/W	R/W	R/W	R/W	R/W	R/W	R/W
Reset	0	0	0	0	0	0	0	0
Bit	23	22	21	20	19	18	17	16
	ADDR[23:16]							
Access	R/W	R/W	R/W	R/W	R/W	R/W	R/W	R/W
Reset	0	0	0	0	0	0	0	0
Bit	15	14	13	12	11	10	9	8
	ADDR[15:8]							
Access	R/W	R/W	R/W	R/W	R/W	R/W	R/W	R/W
Reset	0	0	0	0	0	0	0	0
Bit	7	6	5	4	3	2	1	0
	ADDR[7:0]							
Access	R/W	R/W	R/W	R/W	R/W	R/W	R/W	R/W
Reset	0	0	0	0	0	0	0	0

**Bits 31:0 – ADDR[31:0]** Hash Address  
 Bits 63 to 32 of the Hash Address Register.

## 41.8.22 GMAC Specific Address n Bottom Register

**Name:** SAB  
**Offset:**  $0x88 + n \cdot 0x08$  [ $n=0..3$ ]  
**Reset:** 0x00000000  
**Property:** -

The addresses stored in the Specific Address Registers are deactivated at reset or when their corresponding Specific Address Register Bottom is written. They are activated when Specific Address Register Top is written.

Bit	31	30	29	28	27	26	25	24
	ADDR[31:24]							
Access	R/W	R/W	R/W	R/W	R/W	R/W	R/W	R/W
Reset	0	0	0	0	0	0	0	0
Bit	23	22	21	20	19	18	17	16
	ADDR[23:16]							
Access	R/W	R/W	R/W	R/W	R/W	R/W	R/W	R/W
Reset	0	0	0	0	0	0	0	0
Bit	15	14	13	12	11	10	9	8
	ADDR[15:8]							
Access	R/W	R/W	R/W	R/W	R/W	R/W	R/W	R/W
Reset	0	0	0	0	0	0	0	0
Bit	7	6	5	4	3	2	1	0
	ADDR[7:0]							
Access	R/W	R/W	R/W	R/W	R/W	R/W	R/W	R/W
Reset	0	0	0	0	0	0	0	0

### Bits 31:0 – ADDR[31:0] Specific Address n

Least significant 32 bits of the destination address, that is, bits 31:0. Bit zero indicates whether the address is multicast or unicast and corresponds to the least significant bit of the first byte received.

### 41.8.23 GMAC Specific Address n Top Register

**Name:** SAT  
**Offset:** 0x8C + n\*0x08 [n=0..3]  
**Reset:** 0x00000000  
**Property:** -

The addresses stored in the Specific Address Registers are deactivated at reset or when their corresponding Specific Address Register Bottom is written. They are activated when Specific Address Register Top is written.

Bit	31	30	29	28	27	26	25	24
Access								
Reset								
Bit	23	22	21	20	19	18	17	16
Access								
Reset								
Bit	15	14	13	12	11	10	9	8
	ADDR[15:8]							
Access	R/W	R/W	R/W	R/W	R/W	R/W	R/W	R/W
Reset	0	0	0	0	0	0	0	0
Bit	7	6	5	4	3	2	1	0
	ADDR[7:0]							
Access	R/W	R/W	R/W	R/W	R/W	R/W	R/W	R/W
Reset	0	0	0	0	0	0	0	0

#### Bits 15:0 – ADDR[15:0] Specific Address n

The most significant bits of the destination address, that is, bits 47:32.



#### 41.8.24 GMAC Type ID Match n Register

**Name:** TIDM  
**Offset:** 0xA8 + n\*0x04 [n=0..3]  
**Reset:** 0x00000000  
**Property:** -

Bit	31	30	29	28	27	26	25	24
	ENID							
Access	R/W							
Reset	0							
Bit	23	22	21	20	19	18	17	16
Access								
Reset								
Bit	15	14	13	12	11	10	9	8
	TID[15:8]							
Access	R/W	R/W	R/W	R/W	R/W	R/W	R/W	R/W
Reset	0	0	0	0	0	0	0	0
Bit	7	6	5	4	3	2	1	0
	TID[7:0]							
Access	R/W	R/W	R/W	R/W	R/W	R/W	R/W	R/W
Reset	0	0	0	0	0	0	0	0

#### Bit 31 – ENID Enable Copying of TID n Matched Frames

Value	Description
0	TID n is not part of the comparison match.
1	TID n is processed for the comparison match.

#### Bits 15:0 – TID[15:0] Type ID Match n

For use in comparisons with received frames type ID/length frames.

### 41.8.25 GMAC Wake on LAN Register

**Name:** WOL  
**Offset:** 0x0B8  
**Reset:** 0x00000000  
**Property:** -

Bit	31	30	29	28	27	26	25	24
Access								
Reset								
Bit	23	22	21	20	19	18	17	16
Access					MTI	SA1	ARP	MAG
Reset					0	0	0	0
Bit	15	14	13	12	11	10	9	8
Access	IP[15:8]							
Reset	0	0	0	0	0	0	0	0
Bit	7	6	5	4	3	2	1	0
Access	IP[7:0]							
Reset	0	0	0	0	0	0	0	0

#### Bit 19 – MTI Multicast Hash Event Enable

Value	Description
0	Wake on LAN multicast hash Event disabled
1	Wake on LAN multicast hash Event enabled

#### Bit 18 – SA1 Specific Address Register 1 Event Enable

Value	Description
0	Wake on Specific Address Register 1 Event disabled
1	Wake on Specific Address Register 1 Event enabled

#### Bit 17 – ARP ARP Request Event Enable

Value	Description
0	Wake on LAN ARP request Event disabled
1	Wake on LAN ARP request Event enabled

#### Bit 16 – MAG Magic Packet Event Enable

Value	Description
0	Wake on LAN magic packet Event disabled
1	Wake on LAN magic packet Event enabled

#### Bits 15:0 – IP[15:0] ARP Request IP Address

Wake on LAN ARP request IP address. Written to define the 16 least significant bits of the target IP address that is matched to generate a Wake on LAN event.

Value	Description
0x0000	No Event generated, even if matched by the received frame.
0x0001–0xFFFF	Wake on LAN Event generated for matching LSB of the target IP address.

## 41.8.26 GMAC IPG Stretch Register

**Name:** IPGS  
**Offset:** 0x0BC  
**Reset:** 0x00000000  
**Property:** -

Bit	31	30	29	28	27	26	25	24
Access								
Reset								
Bit	23	22	21	20	19	18	17	16
Access								
Reset								
Bit	15	14	13	12	11	10	9	8
Access	FL[15:8]							
Reset	R/W	R/W	R/W	R/W	R/W	R/W	R/W	R/W
Reset	0	0	0	0	0	0	0	0
Bit	7	6	5	4	3	2	1	0
Access	FL[7:0]							
Reset	R/W	R/W	R/W	R/W	R/W	R/W	R/W	R/W
Reset	0	0	0	0	0	0	0	0

### Bits 15:0 – FL[15:0] Frame Length

Bits FL[7:0] are multiplied with the previously transmitted frame length (including preamble), and divided by FL[15:8]+1 (adding 1 to prevent division by zero).  $RESULT = \frac{FL[7:0]}{F[15+8]+1}$

If RESULT > 96 and the IP Stretch Enable bit in the Network Configuration Register (NCFGR.IPGSEN) is written to '1', RESULT is used for the transmit inter-packet-gap.

### 41.8.27 GMAC Transmit PFC Pause Register

**Name:** TPFPCP  
**Offset:** 0x0C4  
**Reset:** 0x00000000  
**Property:** -

Bit	31	30	29	28	27	26	25	24
Access								
Reset								
Bit	23	22	21	20	19	18	17	16
Access								
Reset								
Bit	15	14	13	12	11	10	9	8
	PQ[7:0]							
Access	R/W	R/W	R/W	R/W	R/W	R/W	R/W	R/W
Reset	0	0	0	0	0	0	0	0
Bit	7	6	5	4	3	2	1	0
	PEV[7:0]							
Access	R/W	R/W	R/W	R/W	R/W	R/W	R/W	R/W
Reset	0	0	0	0	0	0	0	0

#### Bits 15:8 – PQ[7:0] Pause Quantum

When the Remove FCS bit in the GMAC Network Configuration register (NCFGR.RFCS) is written to '1', and one or more bits in this bit field are written to '0', the associated PFC pause frame's pause quantum field value is taken from the Transmit Pause Quantum register (TPQ).  
 For each entry equal to '1' in this bit field, the pause quantum associated with that entry will be zero.

#### Bits 7:0 – PEV[7:0] Priority Enable Vector

When the Remove FCS bit in the GMAC Network Configuration register (NCFGR.RFCS) is written to '1', the priority enable vector of the PFC priority-based pause frame is set to the value stored in this bit field.

## 41.8.28 GMAC Stacked VLAN Register

**Name:** SVLAN  
**Offset:** 0x0C0  
**Reset:** 0x00000000  
**Property:** -

Bit	31	30	29	28	27	26	25	24
	ESVLAN							
Access	-							
Reset	0							
Bit	23	22	21	20	19	18	17	16
Access								
Reset								
Bit	15	14	13	12	11	10	9	8
	VLAN_TYPE[15:8]							
Access	R/W	R/W	R/W	R/W	R/W	R/W	R/W	R/W
Reset	0	0	0	0	0	0	0	0
Bit	7	6	5	4	3	2	1	0
	VLAN_TYPE[7:0]							
Access	R/W	R/W	R/W	R/W	R/W	R/W	R/W	R/W
Reset	0	0	0	0	0	0	0	0

### Bit 31 – ESVLAN Enable Stacked VLAN Processing Mode

0: Disable the stacked VLAN processing mode

1: Enable the stacked VLAN processing mode

Value	Description
0	Stacked VLAN Processing disabled
1	Stacked VLAN Processing enabled

### Bits 15:0 – VLAN\_TYPE[15:0] User Defined VLAN\_TYPE Field

When Stacked VLAN is enabled (ESVLAN=1), the first VLAN tag in a received frame will only be accepted if the VLAN type field is equal to this user defined VLAN\_TYPE, OR equal to the standard VLAN type (0x8100).

**Note:** The second VLAN tag of a Stacked VLAN packet will only be matched correctly if its VLAN\_TYPE field equals 0x8100.

### 41.8.29 GMAC Specific Address 1 Mask Bottom

**Name:** SAMB1  
**Offset:** 0x0C8  
**Reset:** 0x00000000  
**Property:** -

Bit	31	30	29	28	27	26	25	24
	ADDR[31:24]							
Access	R/W	R/W	R/W	R/W	R/W	R/W	R/W	R/W
Reset	0	0	0	0	0	0	0	0
Bit	23	22	21	20	19	18	17	16
	ADDR[23:16]							
Access	R/W	R/W	R/W	R/W	R/W	R/W	R/W	R/W
Reset	0	0	0	0	0	0	0	0
Bit	15	14	13	12	11	10	9	8
	ADDR[15:8]							
Access	R/W	R/W	R/W	R/W	R/W	R/W	R/W	R/W
Reset	0	0	0	0	0	0	0	0
Bit	7	6	5	4	3	2	1	0
	ADDR[7:0]							
Access	R/W	R/W	R/W	R/W	R/W	R/W	R/W	R/W
Reset	0	0	0	0	0	0	0	0

#### Bits 31:0 – ADDR[31:0] Specific Address 1 Mask

Setting a bit to '1' masks the corresponding bit in the Specific Address 1 Bottom register (SAB1).

### 41.8.30 GMAC Specific Address Mask 1 Top

**Name:** SAMT1  
**Offset:** 0x0CC  
**Reset:** 0x00000000  
**Property:** -

Bit	31	30	29	28	27	26	25	24
	[Greyed out bits]							
Access								
Reset								
Bit	23	22	21	20	19	18	17	16
	[Greyed out bits]							
Access								
Reset								
Bit	15	14	13	12	11	10	9	8
	ADDR[15:8]							
Access	R/W	R/W	R/W	R/W	R/W	R/W	R/W	R/W
Reset	0	0	0	0	0	0	0	0
Bit	7	6	5	4	3	2	1	0
	ADDR[7:0]							
Access	R/W	R/W	R/W	R/W	R/W	R/W	R/W	R/W
Reset	0	0	0	0	0	0	0	0

#### Bits 15:0 – ADDR[15:0] Specific Address 1 Mask

Setting a bit to '1' masks the corresponding bit in the Specific Address 1 register SAT1.

### 41.8.31 GMAC 1588 Timer Nanosecond Comparison Register

**Name:** NSC  
**Offset:** 0x0DC  
**Reset:** 0x00000000  
**Property:** -

Bit	31	30	29	28	27	26	25	24	
Access									
Reset									
Bit	23	22	21	20	19	18	17	16	
Access				NANOSEC[20:16]					
Reset				R/W	R/W	R/W	R/W	R/W	
				0	0	0	0	0	
Bit	15	14	13	12	11	10	9	8	
Access	NANOSEC[15:8]								
Reset	R/W	R/W	R/W	R/W	R/W	R/W	R/W	R/W	
	0	0	0	0	0	0	0	0	
Bit	7	6	5	4	3	2	1	0	
Access	NANOSEC[7:0]								
Reset	R/W	R/W	R/W	R/W	R/W	R/W	R/W	R/W	
	0	0	0	0	0	0	0	0	

**Bits 20:0 – NANOSEC[20:0]** 1588 Timer Nanosecond Comparison Value

Value is compared to the bits [45:24] of the TSU timer count value (upper 21 bits of nanosecond value).



### 41.8.32 GMAC 1588 Timer Second Comparison Low Register

**Name:** SCL  
**Offset:** 0x0E0  
**Reset:** 0x00000000  
**Property:** -

Bit	31	30	29	28	27	26	25	24
	SEC[31:24]							
Access	R/W	R/W	R/W	R/W	R/W	R/W	R/W	R/W
Reset	0	0	0	0	0	0	0	0
Bit	23	22	21	20	19	18	17	16
	SEC[23:16]							
Access	R/W	R/W	R/W	R/W	R/W	R/W	R/W	R/W
Reset	0	0	0	0	0	0	0	0
Bit	15	14	13	12	11	10	9	8
	SEC[15:8]							
Access	R/W	R/W	R/W	R/W	R/W	R/W	R/W	R/W
Reset	0	0	0	0	0	0	0	0
Bit	7	6	5	4	3	2	1	0
	SEC[7:0]							
Access	R/W	R/W	R/W	R/W	R/W	R/W	R/W	R/W
Reset	0	0	0	0	0	0	0	0

#### Bits 31:0 – SEC[31:0] 1588 Timer Second Comparison Value

Value is compared to seconds value bits [31:0] of the TSU timer count value.

### 41.8.33 GMAC 1588 Timer Second Comparison High Register

**Name:** SCH  
**Offset:** 0x0E4  
**Reset:** 0x00000000  
**Property:** -

Bit	31	30	29	28	27	26	25	24
Access								
Reset								
Bit	23	22	21	20	19	18	17	16
Access								
Reset								
Bit	15	14	13	12	11	10	9	8
Access	SEC[15:8]							
Reset	R/W	R/W	R/W	R/W	R/W	R/W	R/W	R/W
Reset	0	0	0	0	0	0	0	0
Bit	7	6	5	4	3	2	1	0
Access	SEC[7:0]							
Reset	R/W	R/W	R/W	R/W	R/W	R/W	R/W	R/W
Reset	0	0	0	0	0	0	0	0

#### Bits 15:0 – SEC[15:0] 1588 Timer Second Comparison Value

Value is compared to the top 16 bits (most significant 16 bits [47:32] of seconds value) of the TSU timer count value.

### 41.8.34 GMAC PTP Event Frame Transmitted Seconds High Register

**Name:** EFTSH  
**Offset:** 0x0E8  
**Reset:** 0x00000000  
**Property:** Read-only

Bit	31	30	29	28	27	26	25	24
Access								
Reset								
Bit	23	22	21	20	19	18	17	16
Access								
Reset								
Bit	15	14	13	12	11	10	9	8
Access	RUD[15:8]							
Reset	0	0	0	0	0	0	0	0
Bit	7	6	5	4	3	2	1	0
Access	RUD[7:0]							
Reset	0	0	0	0	0	0	0	0

#### Bits 15:0 – RUD[15:0] Register Update

The register is updated with the value that the IEEE 1588 timer seconds register held when the SFD of a PTP transmit primary event crosses the MII interface. An interrupt is issued when the register is updated.

### 41.8.35 GMAC PTP Event Frame Received Seconds High Register

**Name:** EFRSH  
**Offset:** 0x0EC  
**Reset:** 0x00000000  
**Property:** Read-only

Bit	31	30	29	28	27	26	25	24
Access								
Reset								
Bit	23	22	21	20	19	18	17	16
Access								
Reset								
Bit	15	14	13	12	11	10	9	8
Access	RUD[15:8]							
Reset	R	R	R	R	R	R	R	R
Reset	0	0	0	0	0	0	0	0
Bit	7	6	5	4	3	2	1	0
Access	RUD[7:0]							
Reset	R	R	R	R	R	R	R	R
Reset	0	0	0	0	0	0	0	0

#### Bits 15:0 – RUD[15:0] Register Update

The register is updated with the value that the IEEE 1588 timer seconds register held when the SFD of a PTP transmit primary event crosses the MII interface. An interrupt is issued when the register is updated.

### 41.8.36 GMAC PTP Peer Event Frame Transmitted Seconds High Register

**Name:** PEFTSH  
**Offset:** 0x0F0  
**Reset:** 0x00000000  
**Property:** Read-Only

Bit	31	30	29	28	27	26	25	24
Access								
Reset								
Bit	23	22	21	20	19	18	17	16
Access								
Reset								
Bit	15	14	13	12	11	10	9	8
Access	RUD[15:8]							
Reset	0	0	0	0	0	0	0	0
Bit	7	6	5	4	3	2	1	0
Access	RUD[7:0]							
Reset	0	0	0	0	0	0	0	0

#### Bits 15:0 – RUD[15:0] Register Update

The register is updated with the value that the IEEE 1588 timer seconds register held when the SFD of a PTP transmit peer event crosses the MII interface. An interrupt is issued when the register is updated.

### 41.8.37 GMAC PTP Peer Event Frame Received Seconds High Register

**Name:** PEFRSH  
**Offset:** 0x0F4  
**Reset:** 0x00000000  
**Property:** Read-Only

Bit	31	30	29	28	27	26	25	24
Access								
Reset								
Bit	23	22	21	20	19	18	17	16
Access								
Reset								
Bit	15	14	13	12	11	10	9	8
Access	RUD[15:8]							
Reset	0	0	0	0	0	0	0	0
Bit	7	6	5	4	3	2	1	0
Access	RUD[7:0]							
Reset	0	0	0	0	0	0	0	0

#### Bits 15:0 – RUD[15:0] Register Update

The register is updated with the value that the 1588 timer seconds register held when the SFD of a PTP transmit peer event crosses the MII interface. An interrupt is issued when the register is updated.

### 41.8.38 GMAC Octets Transmitted Low Register

**Name:** OTLO  
**Offset:** 0x100  
**Reset:** 0x00000000  
**Property:** Read-Only

When reading the Octets Transmitted and Octets Received Registers, bits [31:0] should be read prior to bits [47:32] to ensure reliable operation.

Bit	31	30	29	28	27	26	25	24
	TXO[31:24]							
Access	R	R	R	R	R	R	R	R
Reset	0	0	0	0	0	0	0	0
Bit	23	22	21	20	19	18	17	16
	TXO[23:16]							
Access	R	R	R	R	R	R	R	R
Reset	0	0	0	0	0	0	0	0
Bit	15	14	13	12	11	10	9	8
	TXO[15:8]							
Access	R	R	R	R	R	R	R	R
Reset	0	0	0	0	0	0	0	0
Bit	7	6	5	4	3	2	1	0
	TXO[7:0]							
Access	R	R	R	R	R	R	R	R
Reset	0	0	0	0	0	0	0	0

#### Bits 31:0 – TXO[31:0] Transmitted Octets

Transmitted octets in valid frames of any type without errors, bits [31:0]. This counter is 48-bits, and is read through two registers. This count does not include octets from automatically generated pause frames.

### 41.8.39 GMAC Octets Transmitted High Register

**Name:** OTHI  
**Offset:** 0x104  
**Reset:** 0x00000000  
**Property:** Read-Only

When reading the Octets Transmitted and Octets Received Registers, bits [31:0] should be read prior to bits [47:32] to ensure reliable operation.

Bit	31	30	29	28	27	26	25	24
Access								
Reset								
Bit	23	22	21	20	19	18	17	16
Access								
Reset								
Bit	15	14	13	12	11	10	9	8
Access	TXO[15:8]							
Reset	0	0	0	0	0	0	0	0
Bit	7	6	5	4	3	2	1	0
Access	TXO[7:0]							
Reset	0	0	0	0	0	0	0	0

#### Bits 15:0 – TXO[15:0] Transmitted Octets

Transmitted octets in valid frames of any type without errors, bits [47:32]. This counter is 48-bits, and is read through two registers. This count does not include octets from automatically generated pause frames.



#### 41.8.40 GMAC Frames Transmitted

**Name:** FT  
**Offset:** 0x108  
**Reset:** 0x00000000  
**Property:** Read-only

Bit	31	30	29	28	27	26	25	24
	FTX[31:24]							
Access	R	R	R	R	R	R	R	R
Reset	0	0	0	0	0	0	0	0
Bit	23	22	21	20	19	18	17	16
	FTX[23:16]							
Access	R	R	R	R	R	R	R	R
Reset	0	0	0	0	0	0	0	0
Bit	15	14	13	12	11	10	9	8
	FTX[15:8]							
Access	R	R	R	R	R	R	R	R
Reset	0	0	0	0	0	0	0	0
Bit	7	6	5	4	3	2	1	0
	FTX[7:0]							
Access	R	R	R	R	R	R	R	R
Reset	0	0	0	0	0	0	0	0

#### Bits 31:0 – FTX[31:0] Frames Transmitted without Error

Frames transmitted without error. This register counts the number of frames successfully transmitted, i.e., no underrun and not too many retries. Excludes pause frames.

#### 41.8.41 GMAC Broadcast Frames Transmitted Register

**Name:** BCFT  
**Offset:** 0x10C  
**Reset:** 0x00000000  
**Property:** Read-only

Bit	31	30	29	28	27	26	25	24
	BFTX[31:24]							
Access	R	R	R	R	R	R	R	R
Reset	0	0	0	0	0	0	0	0
Bit	23	22	21	20	19	18	17	16
	BFTX[23:16]							
Access	R	R	R	R	R	R	R	R
Reset	0	0	0	0	0	0	0	0
Bit	15	14	13	12	11	10	9	8
	BFTX[15:8]							
Access	R	R	R	R	R	R	R	R
Reset	0	0	0	0	0	0	0	0
Bit	7	6	5	4	3	2	1	0
	BFTX[7:0]							
Access	R	R	R	R	R	R	R	R
Reset	0	0	0	0	0	0	0	0

#### Bits 31:0 – BFTX[31:0] Broadcast Frames Transmitted without Error

This register counts the number of broadcast frames successfully transmitted without error, i.e., no underrun and not too many retries. Excludes pause frames.

#### 41.8.42 GMAC Multicast Frames Transmitted Register

**Name:** MFT  
**Offset:** 0x110  
**Reset:** 0x00000000  
**Property:** Read-Only

Bit	31	30	29	28	27	26	25	24
	MFTX[31:24]							
Access	R	R	R	R	R	R	R	R
Reset	0	0	0	0	0	0	0	0
Bit	23	22	21	20	19	18	17	16
	MFTX[23:16]							
Access	R	R	R	R	R	R	R	R
Reset	0	0	0	0	0	0	0	0
Bit	15	14	13	12	11	10	9	8
	MFTX[15:8]							
Access	R	R	R	R	R	R	R	R
Reset	0	0	0	0	0	0	0	0
Bit	7	6	5	4	3	2	1	0
	MFTX[7:0]							
Access	R	R	R	R	R	R	R	R
Reset	0	0	0	0	0	0	0	0

#### Bits 31:0 – MFTX[31:0] Multicast Frames Transmitted without Error

This register counts the number of multicast frames successfully transmitted without error, i.e., no underrun and not too many retries. Excludes pause frames.

### 41.8.43 GMAC Pause Frames Transmitted Register

**Name:** PFT  
**Offset:** 0x114  
**Reset:** 0x00000000  
**Property:** Read-Only

Bit	31	30	29	28	27	26	25	24
Access								
Reset								
Bit	23	22	21	20	19	18	17	16
Access								
Reset								
Bit	15	14	13	12	11	10	9	8
Access	PFTX[15:8]							
Reset	0	0	0	0	0	0	0	0
Bit	7	6	5	4	3	2	1	0
Access	PFTX[7:0]							
Reset	0	0	0	0	0	0	0	0

#### Bits 15:0 – PFTX[15:0] Pause Frames Transmitted Register

This register counts the number of pause frames transmitted. Only pause frames triggered by the register interface or through the external pause pins are counted as pause frames. Pause frames received through the FIFO interface are counted in the frames transmitted counter.

#### 41.8.44 GMAC 64 Byte Frames Transmitted Register

**Name:** BFT64  
**Offset:** 0x118  
**Reset:** 0x00000000  
**Property:** Read-only

Bit	31	30	29	28	27	26	25	24
	NFTX[31:24]							
Access	R	R	R	R	R	R	R	R
Reset	0	0	0	0	0	0	0	0
Bit	23	22	21	20	19	18	17	16
	NFTX[23:16]							
Access	R	R	R	R	R	R	R	R
Reset	0	0	0	0	0	0	0	0
Bit	15	14	13	12	11	10	9	8
	NFTX[15:8]							
Access	R	R	R	R	R	R	R	R
Reset	0	0	0	0	0	0	0	0
Bit	7	6	5	4	3	2	1	0
	NFTX[7:0]							
Access	R	R	R	R	R	R	R	R
Reset	0	0	0	0	0	0	0	0

#### Bits 31:0 – NFTX[31:0] 64 Byte Frames Transmitted without Error

This register counts the number of 64 byte frames successfully transmitted without error, i.e., no underrun and not too many retries. Excludes pause frames.

### 41.8.45 GMAC 65 to 127 Byte Frames Transmitted Register

**Name:** TBFT127  
**Offset:** 0x11C  
**Reset:** 0x00000000  
**Property:** Read-Only

Bit	31	30	29	28	27	26	25	24
	NFTX[31:24]							
Access	R	R	R	R	R	R	R	R
Reset	0	0	0	0	0	0	0	0
Bit	23	22	21	20	19	18	17	16
	NFTX[23:16]							
Access	R	R	R	R	R	R	R	R
Reset	0	0	0	0	0	0	0	0
Bit	15	14	13	12	11	10	9	8
	NFTX[15:8]							
Access	R	R	R	R	R	R	R	R
Reset	0	0	0	0	0	0	0	0
Bit	7	6	5	4	3	2	1	0
	NFTX[7:0]							
Access	R	R	R	R	R	R	R	R
Reset	0	0	0	0	0	0	0	0

#### Bits 31:0 – NFTX[31:0] 65 to 127 Byte Frames Transmitted without Error

This register counts the number of 65 to 127 byte frames successfully transmitted without error, i.e., no underrun and not too many retries. Excludes pause frames.

#### 41.8.46 GMAC 128 to 255 Byte Frames Transmitted Register

**Name:** TBFT255  
**Offset:** 0x120  
**Reset:** 0x00000000  
**Property:** Read-Only

Bit	31	30	29	28	27	26	25	24
	NFTX[31:24]							
Access	R	R	R	R	R	R	R	R
Reset	0	0	0	0	0	0	0	0
Bit	23	22	21	20	19	18	17	16
	NFTX[23:16]							
Access	R	R	R	R	R	R	R	R
Reset	0	0	0	0	0	0	0	0
Bit	15	14	13	12	11	10	9	8
	NFTX[15:8]							
Access	R	R	R	R	R	R	R	R
Reset	0	0	0	0	0	0	0	0
Bit	7	6	5	4	3	2	1	0
	NFTX[7:0]							
Access	R	R	R	R	R	R	R	R
Reset	0	0	0	0	0	0	0	0

#### Bits 31:0 – NFTX[31:0] 128 to 255 Byte Frames Transmitted without Error

This register counts the number of 128 to 255 byte frames successfully transmitted without error, i.e., no underrun and not too many retries.

#### 41.8.47 GMAC 256 to 511 Byte Frames Transmitted Register

**Name:** TBFT511  
**Offset:** 0x124  
**Reset:** 0x00000000  
**Property:** Read-Only

Bit	31	30	29	28	27	26	25	24
	NFTX[31:24]							
Access	R	R	R	R	R	R	R	R
Reset	0	0	0	0	0	0	0	0
Bit	23	22	21	20	19	18	17	16
	NFTX[23:16]							
Access	R	R	R	R	R	R	R	R
Reset	0	0	0	0	0	0	0	0
Bit	15	14	13	12	11	10	9	8
	NFTX[15:8]							
Access	R	R	R	R	R	R	R	R
Reset	0	0	0	0	0	0	0	0
Bit	7	6	5	4	3	2	1	0
	NFTX[7:0]							
Access	R	R	R	R	R	R	R	R
Reset	0	0	0	0	0	0	0	0

#### Bits 31:0 – NFTX[31:0] 256 to 511 Byte Frames Transmitted without Error

This register counts the number of 256 to 511 byte frames successfully transmitted without error, i.e., no underrun and not too many retries.



#### 41.8.48 GMAC 512 to 1023 Byte Frames Transmitted Register

**Name:** TBFT1023  
**Offset:** 0x128  
**Reset:** 0x00000000  
**Property:** Read-Only

Bit	31	30	29	28	27	26	25	24
	NFTX[31:24]							
Access	R	R	R	R	R	R	R	R
Reset	0	0	0	0	0	0	0	0
Bit	23	22	21	20	19	18	17	16
	NFTX[23:16]							
Access	R	R	R	R	R	R	R	R
Reset	0	0	0	0	0	0	0	0
Bit	15	14	13	12	11	10	9	8
	NFTX[15:8]							
Access	R	R	R	R	R	R	R	R
Reset	0	0	0	0	0	0	0	0
Bit	7	6	5	4	3	2	1	0
	NFTX[7:0]							
Access	R	R	R	R	R	R	R	R
Reset	0	0	0	0	0	0	0	0

#### Bits 31:0 – NFTX[31:0] 512 to 1023 Byte Frames Transmitted without Error

This register counts the number of 512 to 1023 byte frames successfully transmitted without error, i.e., no underrun and not too many retries.

#### 41.8.49 GMAC 1024 to 1518 Byte Frames Transmitted Register

**Name:** TBFT1518  
**Offset:** 0x12C  
**Reset:** 0x00000000  
**Property:** Read-Only

Bit	31	30	29	28	27	26	25	24
	NFTX[31:24]							
Access	R	R	R	R	R	R	R	R
Reset	0	0	0	0	0	0	0	0
Bit	23	22	21	20	19	18	17	16
	NFTX[23:16]							
Access	R	R	R	R	R	R	R	R
Reset	0	0	0	0	0	0	0	0
Bit	15	14	13	12	11	10	9	8
	NFTX[15:8]							
Access	R	R	R	R	R	R	R	R
Reset	0	0	0	0	0	0	0	0
Bit	7	6	5	4	3	2	1	0
	NFTX[7:0]							
Access	R	R	R	R	R	R	R	R
Reset	0	0	0	0	0	0	0	0

#### Bits 31:0 – NFTX[31:0] 1024 to 1518 Byte Frames Transmitted without Error

This register counts the number of 1024 to 1518 byte frames successfully transmitted without error, i.e., no underrun and not too many retries.

### 41.8.50 GMAC Greater Than 1518 Byte Frames Transmitted Register

**Name:** GTBFT1518  
**Offset:** 0x130  
**Reset:** 0x00000000  
**Property:** Read-only

Bit	31	30	29	28	27	26	25	24
	NFTX[31:24]							
Access	R	R	R	R	R	R	R	R
Reset	0	0	0	0	0	0	0	0
Bit	23	22	21	20	19	18	17	16
	NFTX[23:16]							
Access	R	R	R	R	R	R	R	R
Reset	0	0	0	0	0	0	0	0
Bit	15	14	13	12	11	10	9	8
	NFTX[15:8]							
Access	R	R	R	R	R	R	R	R
Reset	0	0	0	0	0	0	0	0
Bit	7	6	5	4	3	2	1	0
	NFTX[7:0]							
Access	R	R	R	R	R	R	R	R
Reset	0	0	0	0	0	0	0	0

#### Bits 31:0 – NFTX[31:0] Greater than 1518 Byte Frames Transmitted without Error

This register counts the number of 1518 or above byte frames successfully transmitted without error i.e., no underrun and not too many retries.

### 41.8.51 GMAC Transmit Underruns Register

**Name:** TUR  
**Offset:** 0x134  
**Reset:** 0x00000000  
**Property:** Read-Only

Bit	31	30	29	28	27	26	25	24
Access								
Reset								
Bit	23	22	21	20	19	18	17	16
Access								
Reset								
Bit	15	14	13	12	11	10	9	8
Access							TXUNR[9:8]	
Reset							R	R
							0	0
Bit	7	6	5	4	3	2	1	0
Access	TXUNR[7:0]							
Reset	R	R	R	R	R	R	R	R
	0	0	0	0	0	0	0	0

#### Bits 9:0 – TXUNR[9:0] Transmit Underruns

This register counts the number of frames not transmitted due to a transmit underrun. If this register is incremented then no other statistics register is incremented.

### 41.8.52 GMAC Single Collision Frames Register

**Name:** SCF  
**Offset:** 0x138  
**Reset:** 0x00000000  
**Property:** -

Bit	31	30	29	28	27	26	25	24
Access								
Reset								
Bit	23	22	21	20	19	18	17	16
							SCOL[17:16]	
Access							R	R
Reset							0	0
Bit	15	14	13	12	11	10	9	8
	SCOL[15:8]							
Access	R	R	R	R	R	R	R	R
Reset	0	0	0	0	0	0	0	0
Bit	7	6	5	4	3	2	1	0
	SCOL[7:0]							
Access	R	R	R	R	R	R	R	R
Reset	0	0	0	0	0	0	0	0

#### Bits 17:0 – SCOL[17:0] Single Collision

This register counts the number of frames experiencing a single collision before being successfully transmitted i.e., no underrun.

### 41.8.53 GMAC Multiple Collision Frames Register

**Name:** MCF  
**Offset:** 0x13C  
**Reset:** 0x00000000  
**Property:** Read-Only

Bit	31	30	29	28	27	26	25	24
Access								
Reset								
Bit	23	22	21	20	19	18	17	16
Access							MCOL[17:16]	
Reset							R	R
Reset							0	0
Bit	15	14	13	12	11	10	9	8
Access	MCOL[15:8]							
Reset	R	R	R	R	R	R	R	R
Reset	0	0	0	0	0	0	0	0
Bit	7	6	5	4	3	2	1	0
Access	MCOL[7:0]							
Reset	R	R	R	R	R	R	R	R
Reset	0	0	0	0	0	0	0	0

#### Bits 17:0 – MCOL[17:0] Multiple Collision

This register counts the number of frames experiencing between two and fifteen collisions prior to being successfully transmitted, i.e., no underrun and not too many retries.

#### 41.8.54 GMAC Excessive Collisions Register

**Name:** EC  
**Offset:** 0x140  
**Reset:** 0x00000000  
**Property:** Read-only

Bit	31	30	29	28	27	26	25	24
Access								
Reset								
Bit	23	22	21	20	19	18	17	16
Access								
Reset								
Bit	15	14	13	12	11	10	9	8
Access							XCOL[9:8]	
Reset							R	R
							0	0
Bit	7	6	5	4	3	2	1	0
Access	XCOL[7:0]							
Reset	R	R	R	R	R	R	R	R
	0	0	0	0	0	0	0	0

#### Bits 9:0 – XCOL[9:0] Excessive Collisions

This register counts the number of frames that failed to be transmitted because they experienced 16 collisions.

### 41.8.55 GMAC Late Collisions Register

**Name:** LC  
**Offset:** 0x144  
**Reset:** 0x00000000  
**Property:** Read-Only

Bit	31	30	29	28	27	26	25	24
Access								
Reset								
Bit	23	22	21	20	19	18	17	16
Access								
Reset								
Bit	15	14	13	12	11	10	9	8
Access							LCOL[9:8]	
Reset							R	R
							0	0
Bit	7	6	5	4	3	2	1	0
Access	LCOL[7:0]							
Reset	R	R	R	R	R	R	R	R
	0	0	0	0	0	0	0	0

#### Bits 9:0 - LCOL[9:0] Late Collisions

This register counts the number of late collisions occurring after the slot time (512 bits) has expired. In 10/100 mode, late collisions are counted twice i.e., both as a collision and a late collision.



### 41.8.56 GMAC Deferred Transmission Frames Register

**Name:** DTF  
**Offset:** 0x148  
**Reset:** 0x00000000  
**Property:** Read-only

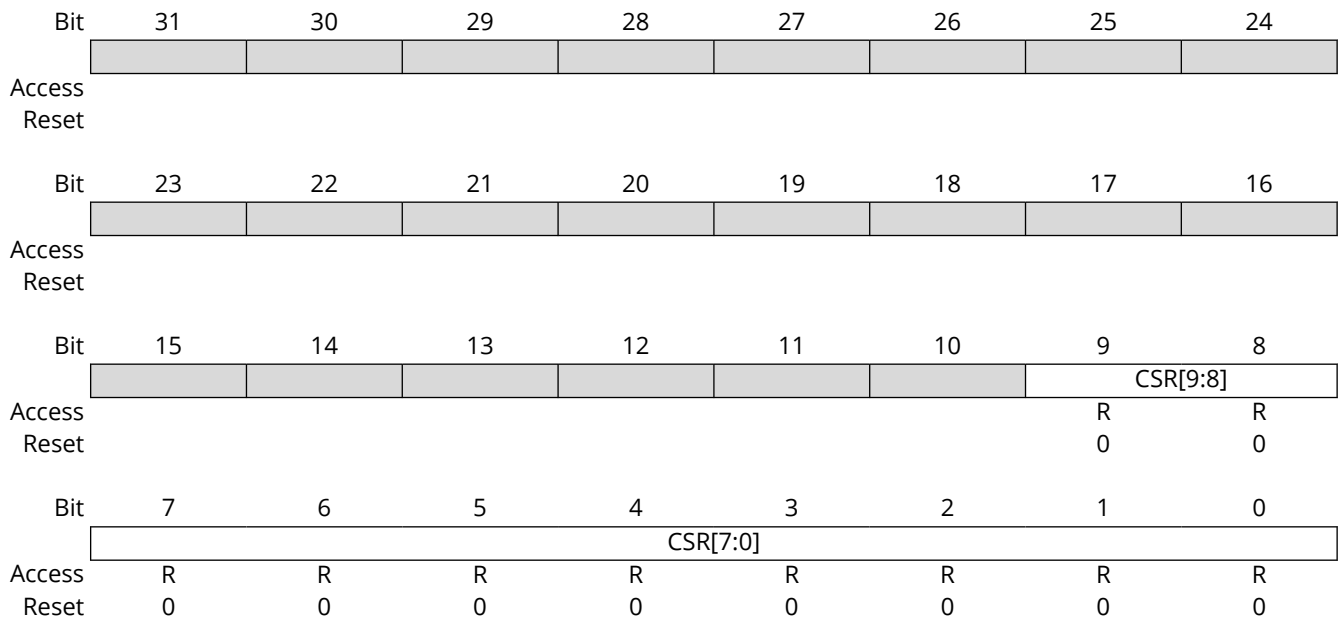
Bit	31	30	29	28	27	26	25	24
Access								
Reset								
Bit	23	22	21	20	19	18	17	16
Access							DEFT[17:16]	
Reset							R	R
Reset							0	0
Bit	15	14	13	12	11	10	9	8
Access	DEFT[15:8]							
Reset	R	R	R	R	R	R	R	R
Reset	0	0	0	0	0	0	0	0
Bit	7	6	5	4	3	2	1	0
Access	DEFT[7:0]							
Reset	R	R	R	R	R	R	R	R
Reset	0	0	0	0	0	0	0	0

#### Bits 17:0 – DEFT[17:0] Deferred Transmission

This register counts the number of frames experiencing deferral due to carrier sense being active on their first attempt at transmission. Frames involved in any collision are not counted nor are frames that experienced a transmit underrun.

### 41.8.57 GMAC Carrier Sense Errors Register

**Name:** CSE  
**Offset:** 0x14C  
**Reset:** 0x00000000  
**Property:** Read-only



#### Bits 9:0 – CSR[9:0] Carrier Sense Error

This register counts the number of frames transmitted with carrier sense was not seen during transmission or where carrier sense was de-asserted after being asserted in a transmit frame without collision (no underrun). Only incremented in half duplex mode. The only effect of a carrier sense error is to increment this register. The behavior of the other statistics registers is unaffected by the detection of a carrier sense error.

### 41.8.58 GMAC Octets Received Low Register

**Name:** ORLO  
**Offset:** 0x150  
**Reset:** 0x00000000  
**Property:** Read-Only

When reading the Octets Transmitted and Octets Received Registers, bits [31:0] should be read prior to bits [47:32] to ensure reliable operation.

Bit	31	30	29	28	27	26	25	24
	RXO[31:24]							
Access	R	R	R	R	R	R	R	R
Reset	0	0	0	0	0	0	0	0
Bit	23	22	21	20	19	18	17	16
	RXO[23:16]							
Access	R	R	R	R	R	R	R	R
Reset	0	0	0	0	0	0	0	0
Bit	15	14	13	12	11	10	9	8
	RXO[15:8]							
Access	R	R	R	R	R	R	R	R
Reset	0	0	0	0	0	0	0	0
Bit	7	6	5	4	3	2	1	0
	RXO[7:0]							
Access	R	R	R	R	R	R	R	R
Reset	0	0	0	0	0	0	0	0

#### Bits 31:0 – RXO[31:0] Received Octets

Received octets in frame without errors [31:0]. The number of octets received in valid frames of any type. This counter is 48-bits and is read through two registers. This count does not include octets from pause frames, and is only incremented if the frame is successfully filtered and copied to memory.

### 41.8.59 GMAC Octets Received High Register

**Name:** ORHI  
**Offset:** 0x154  
**Reset:** 0x00000000  
**Property:** Read-only

When reading the Octets Transmitted and Octets Received Registers, bits 31:0 should be read prior to bits 47:32 to ensure reliable operation.

Bit	31	30	29	28	27	26	25	24
	[Register Bit Field]							
Access								
Reset								
Bit	23	22	21	20	19	18	17	16
	[Register Bit Field]							
Access								
Reset								
Bit	15	14	13	12	11	10	9	8
	RXO[15:8]							
Access	R	R	R	R	R	R	R	R
Reset	0	0	0	0	0	0	0	0
Bit	7	6	5	4	3	2	1	0
	RXO[7:0]							
Access	R	R	R	R	R	R	R	R
Reset	0	0	0	0	0	0	0	0

#### Bits 15:0 – RXO[15:0] Received Octets

Received octets in frame without errors [47:32]. The number of octets received in valid frames of any type. This counter is 48-bits and is read through two registers. This count does not include octets from pause frames, and is only incremented if the frame is successfully filtered and copied to memory.

### 41.8.60 GMAC Frames Received Register

**Name:** FR  
**Offset:** 0x158  
**Reset:** 0x00000000  
**Property:** Read-only

Bit	31	30	29	28	27	26	25	24
	FRX[31:24]							
Access	R	R	R	R	R	R	R	R
Reset	0	0	0	0	0	0	0	0
Bit	23	22	21	20	19	18	17	16
	FRX[23:16]							
Access	R	R	R	R	R	R	R	R
Reset	0	0	0	0	0	0	0	0
Bit	15	14	13	12	11	10	9	8
	FRX[15:8]							
Access	R	R	R	R	R	R	R	R
Reset	0	0	0	0	0	0	0	0
Bit	7	6	5	4	3	2	1	0
	FRX[7:0]							
Access	R	R	R	R	R	R	R	R
Reset	0	0	0	0	0	0	0	0

**Bits 31:0 – FRX[31:0]** Frames Received without Error

This bit field counts the number of frames successfully received, excluding pause frames. It is only incremented if the frame is successfully filtered and copied to memory.

### 41.8.61 GMAC Broadcast Frames Received Register

**Name:** BCFR  
**Offset:** 0x15C  
**Reset:** 0x00000000  
**Property:** Read-only

Bit	31	30	29	28	27	26	25	24
	BFRX[31:24]							
Access	R	R	R	R	R	R	R	R
Reset	0	0	0	0	0	0	0	0
Bit	23	22	21	20	19	18	17	16
	BFRX[23:16]							
Access	R	R	R	R	R	R	R	R
Reset	0	0	0	0	0	0	0	0
Bit	15	14	13	12	11	10	9	8
	BFRX[15:8]							
Access	R	R	R	R	R	R	R	R
Reset	0	0	0	0	0	0	0	0
Bit	7	6	5	4	3	2	1	0
	BFRX[7:0]							
Access	R	R	R	R	R	R	R	R
Reset	0	0	0	0	0	0	0	0

**Bits 31:0 – BFRX[31:0]** Broadcast Frames Received without Error

Broadcast frames received without error. This bit field counts the number of broadcast frames successfully received. This excludes pause frames, and is only incremented if the frame is successfully filtered and copied to memory.

## 41.8.62 GMAC Multicast Frames Received Register

**Name:** MFR  
**Offset:** 0x160  
**Reset:** 0x00000000  
**Property:** Read-only

Bit	31	30	29	28	27	26	25	24
	MFRX[31:24]							
Access	R	R	R	R	R	R	R	R
Reset	0	0	0	0	0	0	0	0
Bit	23	22	21	20	19	18	17	16
	MFRX[23:16]							
Access	R	R	R	R	R	R	R	R
Reset	0	0	0	0	0	0	0	0
Bit	15	14	13	12	11	10	9	8
	MFRX[15:8]							
Access	R	R	R	R	R	R	R	R
Reset	0	0	0	0	0	0	0	0
Bit	7	6	5	4	3	2	1	0
	MFRX[7:0]							
Access	R	R	R	R	R	R	R	R
Reset	0	0	0	0	0	0	0	0

### Bits 31:0 – MFRX[31:0] Multicast Frames Received without Error

This register counts the number of multicast frames successfully received without error, excluding pause frames, and is only incremented if the frame is successfully filtered and copied to memory.

### 41.8.63 GMAC Pause Frames Received Register

**Name:** PFR  
**Offset:** 0x164  
**Reset:** 0x00000000  
**Property:** Read-Only

Bit	31	30	29	28	27	26	25	24
Access								
Reset								
Bit	23	22	21	20	19	18	17	16
Access								
Reset								
Bit	15	14	13	12	11	10	9	8
Access	PFRX[15:8]							
Reset	R	R	R	R	R	R	R	R
Reset	0	0	0	0	0	0	0	0
Bit	7	6	5	4	3	2	1	0
Access	PFRX[7:0]							
Reset	R	R	R	R	R	R	R	R
Reset	0	0	0	0	0	0	0	0

#### Bits 15:0 – PFRX[15:0] Pause Frames Received Register

This register counts the number of pause frames received without error.



### 41.8.64 GMAC 64 Byte Frames Received Register

**Name:** BFR64  
**Offset:** 0x168  
**Reset:** 0x00000000  
**Property:** Read-only

Bit	31	30	29	28	27	26	25	24
	NFRX[31:24]							
Access	R	R	R	R	R	R	R	R
Reset	0	0	0	0	0	0	0	0
Bit	23	22	21	20	19	18	17	16
	NFRX[23:16]							
Access	R	R	R	R	R	R	R	R
Reset	0	0	0	0	0	0	0	0
Bit	15	14	13	12	11	10	9	8
	NFRX[15:8]							
Access	R	R	R	R	R	R	R	R
Reset	0	0	0	0	0	0	0	0
Bit	7	6	5	4	3	2	1	0
	NFRX[7:0]							
Access	R	R	R	R	R	R	R	R
Reset	0	0	0	0	0	0	0	0

**Bits 31:0 – NFRX[31:0]** 64 Byte Frames Received without Error

This bit field counts the number of 64 byte frames successfully received without error. Excludes pause frames, and is only incremented if the frame is successfully filtered and copied to memory.

### 41.8.65 GMAC 65 to 127 Byte Frames Received Register

**Name:** TBFR127  
**Offset:** 0x16C  
**Reset:** 0x00000000  
**Property:** Read-Only

Bit	31	30	29	28	27	26	25	24
	NFRX[31:24]							
Access	R	R	R	R	R	R	R	R
Reset	0	0	0	0	0	0	0	0
Bit	23	22	21	20	19	18	17	16
	NFRX[23:16]							
Access	R	R	R	R	R	R	R	R
Reset	0	0	0	0	0	0	0	0
Bit	15	14	13	12	11	10	9	8
	NFRX[15:8]							
Access	R	R	R	R	R	R	R	R
Reset	0	0	0	0	0	0	0	0
Bit	7	6	5	4	3	2	1	0
	NFRX[7:0]							
Access	R	R	R	R	R	R	R	R
Reset	0	0	0	0	0	0	0	0

#### Bits 31:0 – NFRX[31:0] 65 to 127 Byte Frames Received without Error

This bit field counts the number of 65 to 127 byte frames successfully received without error. Excludes pause frames, and is only incremented if the frame is successfully filtered and copied to memory.

### 41.8.66 GMAC 128 to 255 Byte Frames Received Register

**Name:** TBFR255  
**Offset:** 0x170  
**Reset:** 0x00000000  
**Property:** Read-Only

Bit	31	30	29	28	27	26	25	24
	NFRX[31:24]							
Access	R	R	R	R	R	R	R	R
Reset	0	0	0	0	0	0	0	0
Bit	23	22	21	20	19	18	17	16
	NFRX[23:16]							
Access	R	R	R	R	R	R	R	R
Reset	0	0	0	0	0	0	0	0
Bit	15	14	13	12	11	10	9	8
	NFRX[15:8]							
Access	R	R	R	R	R	R	R	R
Reset	0	0	0	0	0	0	0	0
Bit	7	6	5	4	3	2	1	0
	NFRX[7:0]							
Access	R	R	R	R	R	R	R	R
Reset	0	0	0	0	0	0	0	0

#### Bits 31:0 – NFRX[31:0] 128 to 255 Byte Frames Received without Error

This bit field counts the number of 128 to 255 byte frames successfully received without error. Excludes pause frames, and is only incremented if the frame is successfully filtered and copied to memory.

### 41.8.67 GMAC 256 to 511 Byte Frames Received Register

**Name:** TBFR511  
**Offset:** 0x174  
**Reset:** 0x00000000  
**Property:** Read-Only

Bit	31	30	29	28	27	26	25	24
	NFRX[31:24]							
Access	R	R	R	R	R	R	R	R
Reset	0	0	0	0	0	0	0	0
Bit	23	22	21	20	19	18	17	16
	NFRX[23:16]							
Access	R	R	R	R	R	R	R	R
Reset	0	0	0	0	0	0	0	0
Bit	15	14	13	12	11	10	9	8
	NFRX[15:8]							
Access	R	R	R	R	R	R	R	R
Reset	0	0	0	0	0	0	0	0
Bit	7	6	5	4	3	2	1	0
	NFRX[7:0]							
Access	R	R	R	R	R	R	R	R
Reset	0	0	0	0	0	0	0	0

#### Bits 31:0 – NFRX[31:0] 256 to 511 Byte Frames Received without Error

This bit fields counts the number of 256 to 511 byte frames successfully received without error. Excludes pause frames, and is only incremented if the frame is successfully filtered and copied to memory.

### 41.8.68 GMAC 512 to 1023 Byte Frames Received Register

**Name:** TBFR1023  
**Offset:** 0x178  
**Reset:** 0x00000000  
**Property:** Read-Only

Bit	31	30	29	28	27	26	25	24
	NFRX[31:24]							
Access	R	R	R	R	R	R	R	R
Reset	0	0	0	0	0	0	0	0
Bit	23	22	21	20	19	18	17	16
	NFRX[23:16]							
Access	R	R	R	R	R	R	R	R
Reset	0	0	0	0	0	0	0	0
Bit	15	14	13	12	11	10	9	8
	NFRX[15:8]							
Access	R	R	R	R	R	R	R	R
Reset	0	0	0	0	0	0	0	0
Bit	7	6	5	4	3	2	1	0
	NFRX[7:0]							
Access	R	R	R	R	R	R	R	R
Reset	0	0	0	0	0	0	0	0

#### Bits 31:0 – NFRX[31:0] 512 to 1023 Byte Frames Received without Error

This bit field counts the number of 512 to 1023 byte frames successfully received without error. Excludes pause frames, and is only incremented if the frame is successfully filtered and copied to memory.

### 41.8.69 GMAC 1024 to 1518 Byte Frames Received Register

**Name:** TBFR1518  
**Offset:** 0x17C  
**Reset:** 0x00000000  
**Property:** Read-Only

Bit	31	30	29	28	27	26	25	24
	NFRX[31:24]							
Access	R	R	R	R	R	R	R	R
Reset	0	0	0	0	0	0	0	0
Bit	23	22	21	20	19	18	17	16
	NFRX[23:16]							
Access	R	R	R	R	R	R	R	R
Reset	0	0	0	0	0	0	0	0
Bit	15	14	13	12	11	10	9	8
	NFRX[15:8]							
Access	R	R	R	R	R	R	R	R
Reset	0	0	0	0	0	0	0	0
Bit	7	6	5	4	3	2	1	0
	NFRX[7:0]							
Access	R	R	R	R	R	R	R	R
Reset	0	0	0	0	0	0	0	0

#### Bits 31:0 – NFRX[31:0] 1024 to 1518 Byte Frames Received without Error

This bit field counts the number of 1024 to 1518 byte frames successfully received without error, i.e., no underrun and not too many retries.

### 41.8.70 GMAC 1519 to Maximum Byte Frames Received Register

**Name:** TMXBFR  
**Offset:** 0x180  
**Reset:** 0x00000000  
**Property:** Read-Only

Bit	31	30	29	28	27	26	25	24
	NFRX[31:24]							
Access	R	R	R	R	R	R	R	R
Reset	0	0	0	0	0	0	0	0
Bit	23	22	21	20	19	18	17	16
	NFRX[23:16]							
Access	R	R	R	R	R	R	R	R
Reset	0	0	0	0	0	0	0	0
Bit	15	14	13	12	11	10	9	8
	NFRX[15:8]							
Access	R	R	R	R	R	R	R	R
Reset	0	0	0	0	0	0	0	0
Bit	7	6	5	4	3	2	1	0
	NFRX[7:0]							
Access	R	R	R	R	R	R	R	R
Reset	0	0	0	0	0	0	0	0

#### Bits 31:0 – NFRX[31:0] 1519 to Maximum Byte Frames Received without Error

This bit field counts the number of 1519 Byte or above frames successfully received without error. Maximum frame size is determined by the Maximum Frame Size bit (MAXFS, 1536 Bytes) or Jumbo Frame Size bit (JFRAME, 10240 Bytes) in the Network Configuration Register (NCFGR). Excludes pause frames, and is only incremented if the frame is successfully filtered and copied to memory.

### 41.8.71 GMAC Undersized Frames Received Register

**Name:** UFR  
**Offset:** 0x184  
**Reset:** 0x00000000  
**Property:** Read-Only

Bit	31	30	29	28	27	26	25	24
Access								
Reset								
Bit	23	22	21	20	19	18	17	16
Access								
Reset								
Bit	15	14	13	12	11	10	9	8
Access							UFRX[9:8]	
Reset							R	R
							0	0
Bit	7	6	5	4	3	2	1	0
Access	UFRX[7:0]							
Reset	R	R	R	R	R	R	R	R
	0	0	0	0	0	0	0	0

#### Bits 9:0 - UFRX[9:0] Undersize Frames Received

This bit field counts the number of frames received less than 64 bytes in length (10/100 mode, full duplex) that do not have either a CRC error or an alignment error.



### 41.8.72 GMAC Oversized Frames Received Register

**Name:** OFR  
**Offset:** 0x188  
**Reset:** 0x00000000  
**Property:** Read-Only

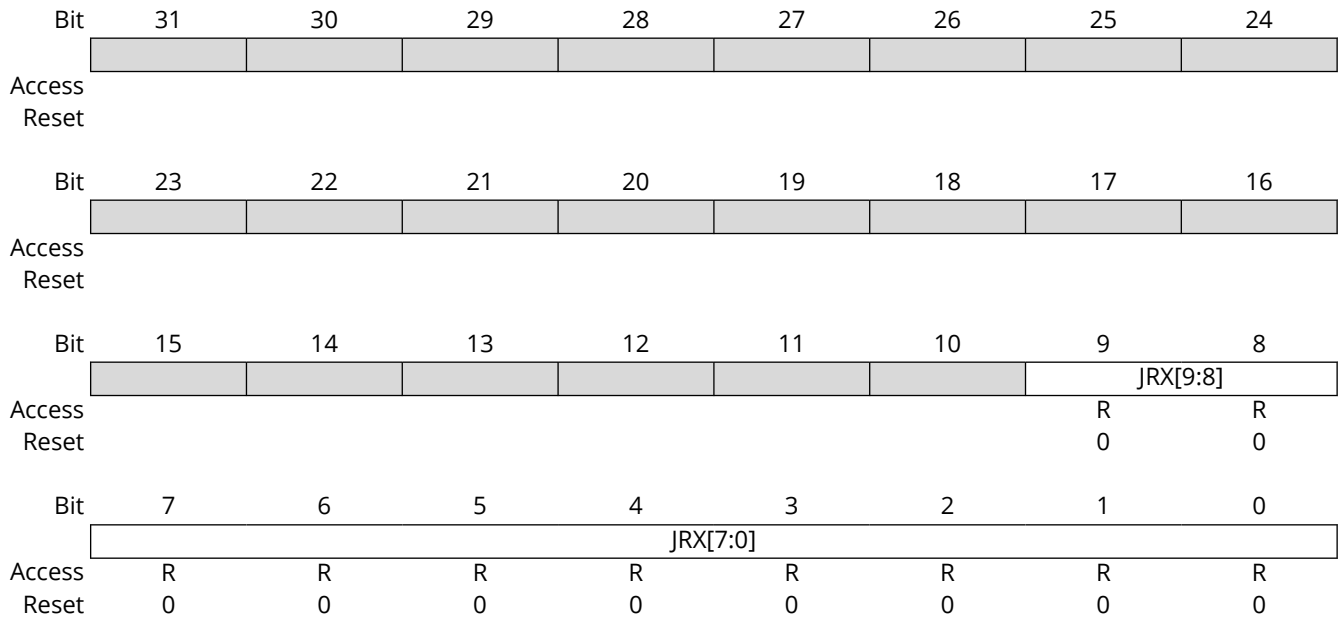
Bit	31	30	29	28	27	26	25	24
Access								
Reset								
Bit	23	22	21	20	19	18	17	16
Access								
Reset								
Bit	15	14	13	12	11	10	9	8
Access							OFRX[9:8]	
Reset							R	R
							0	0
Bit	7	6	5	4	3	2	1	0
Access	OFRX[7:0]							
Reset	R	R	R	R	R	R	R	R
	0	0	0	0	0	0	0	0

#### Bits 9:0 - OFRX[9:0] Oversized Frames Received

This bit field counts the number of frames received exceeding 1518 Bytes in length (1536 Bytes if NCFGR.MAXFS is written to '1') but do not have either a CRC error, an alignment error, nor a receive symbol error.

### 41.8.73 GMAC Jabbers Received Register

**Name:** JR  
**Offset:** 0x18C  
**Reset:** 0x00000000  
**Property:** Read-Only

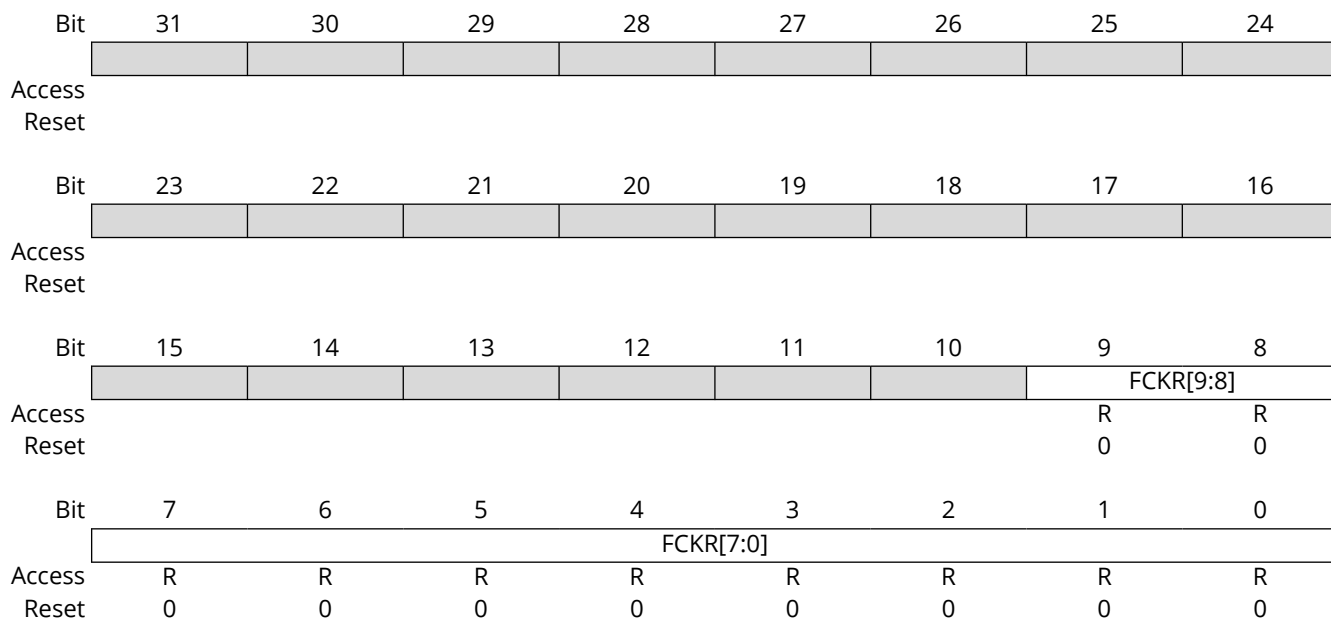


#### Bits 9:0 – JRX[9:0] Jabbers Received

This bit field counts the number of frames received exceeding 1518 Bytes in length (1536 Bytes if NCFGR.MAXFS is written to '1') and have either a CRC error, an alignment error or a receive symbol error.

#### 41.8.74 GMAC Frame Check Sequence Errors Register

**Name:** FCSE  
**Offset:** 0x190  
**Reset:** 0x00000000  
**Property:** Read-only



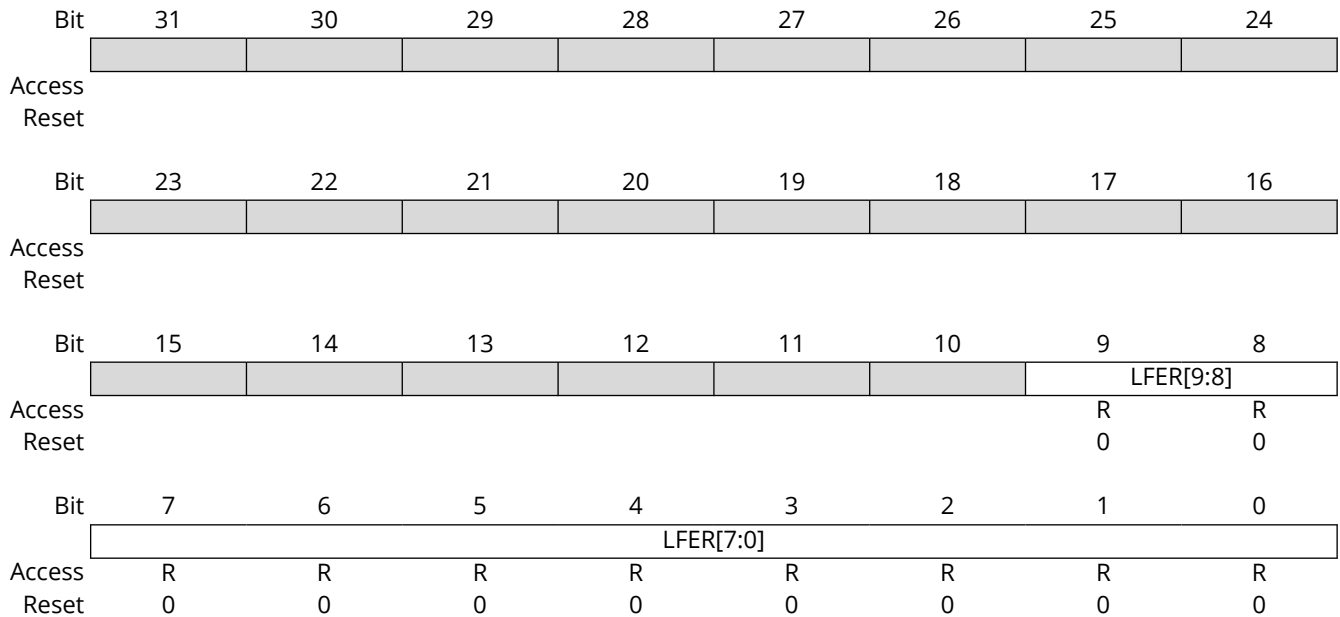
#### Bits 9:0 – FCKR[9:0] Frame Check Sequence Errors

The register counts frames that are an integral number of bytes, have bad CRC and are between 64 and 1518 bytes in length (1536 Bytes if NCFGR.MAXFS is written to '1'). This register is also incremented if a symbol error is detected and the frame is of valid length and has an integral number of bytes.

This register is incremented for a frame with bad FCS, regardless of whether it is copied to memory due to ignore FCS mode (enabled by writing NCFGR.IRXFCS=1).

### 41.8.75 GMAC Length Field Frame Errors Register

**Name:** LFFE  
**Offset:** 0x194  
**Reset:** 0x00000000  
**Property:** Read-Only



#### Bits 9:0 – LFER[9:0] Length Field Frame Errors

This bit field counts the number of frames received that have a measured length shorter than that extracted from the length field (Bytes 13 and 14). This condition is only counted if the value of the length field is less than 0x0600, the frame is not of excessive length and checking is enabled by writing a '1' to the Length Field Error Frame Discard bit in the Network Configuration Register (GMAC\_NCFGR.LFERD).

### 41.8.76 GMAC Receive Symbol Errors Register

**Name:** RSE  
**Offset:** 0x198  
**Reset:** 0x00000000  
**Property:** Read-only

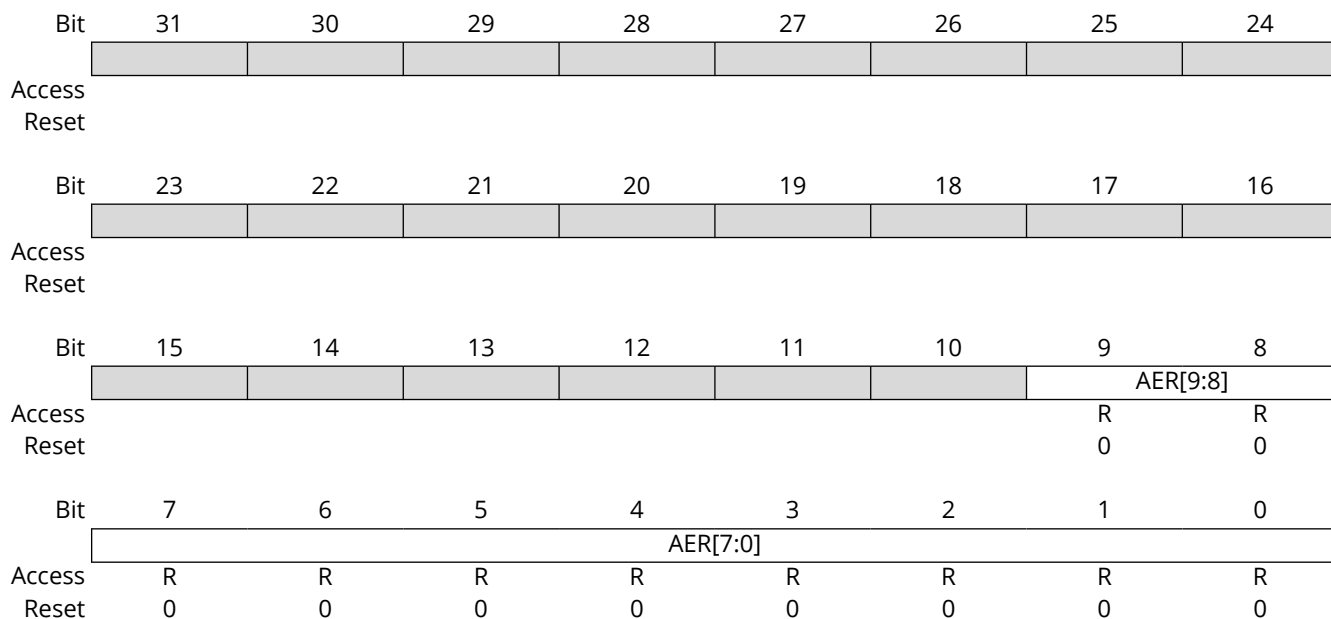
Bit	31	30	29	28	27	26	25	24
Access								
Reset								
Bit	23	22	21	20	19	18	17	16
Access								
Reset								
Bit	15	14	13	12	11	10	9	8
Access							RXSE[9:8]	
Reset							R	R
							0	0
Bit	7	6	5	4	3	2	1	0
Access	RXSE[7:0]							
Reset	R	R	R	R	R	R	R	R
	0	0	0	0	0	0	0	0

#### Bits 9:0 – RXSE[9:0] Receive Symbol Errors

This bit field counts the number of frames that had GRXER asserted during reception. For 10/100 mode symbol errors are counted regardless of frame length checks. Receive symbol errors will also be counted as an FCS or alignment error if the frame is between 64 and 1518 Bytes (1536 Bytes if NCFGR.MAXFS=1). If the frame is larger it will be recorded as a jabber error.

### 41.8.77 GMAC Alignment Errors Register

**Name:** AE  
**Offset:** 0x19C  
**Reset:** 0x00000000  
**Property:** Read-only



#### Bits 9:0 – AER[9:0] Alignment Errors

This bit field counts the frames that are not an integral number of bytes long and have bad CRC when their length is truncated to an integral number of Bytes and are between 64 and 1518 Bytes in length (1536 if NCFGR.MAXFS=1). This register is also incremented if a symbol error is detected and the frame is of valid length and does not have an integral number of bytes.

### 41.8.78 GMAC Receive Resource Errors Register

**Name:** RRE  
**Offset:** 0x1A0  
**Reset:** 0x00000000  
**Property:** Read-Only

Bit	31	30	29	28	27	26	25	24
Access								
Reset								
Bit	23	22	21	20	19	18	17	16
Access							RXRER[17:16]	
Reset							R	R
							0	0
Bit	15	14	13	12	11	10	9	8
Access	RXRER[15:8]							
Reset	R	R	R	R	R	R	R	R
	0	0	0	0	0	0	0	0
Bit	7	6	5	4	3	2	1	0
Access	RXRER[7:0]							
Reset	R	R	R	R	R	R	R	R
	0	0	0	0	0	0	0	0

#### Bits 17:0 – RXRER[17:0] Receive Resource Errors

This bit field counts frames that are not an integral number of bytes long and have bad CRC when their length is truncated to an integral number of Bytes and are between 64 and 1518 Bytes in length (1536 if NCFGR.MAXFS=1). This bit field is also incremented if a symbol error is detected and the frame is of valid length and does not have an integral number of Bytes.

### 41.8.79 GMAC Receive Overruns Register

**Name:** ROE  
**Offset:** 0x1A4  
**Reset:** 0x00000000  
**Property:** Read-Only

Bit	31	30	29	28	27	26	25	24
Access								
Reset								
Bit	23	22	21	20	19	18	17	16
Access								
Reset								
Bit	15	14	13	12	11	10	9	8
Access							RXOVR[9:8]	
Reset							R	R
							0	0
Bit	7	6	5	4	3	2	1	0
Access	RXOVR[7:0]							
Reset	R	R	R	R	R	R	R	R
	0	0	0	0	0	0	0	0

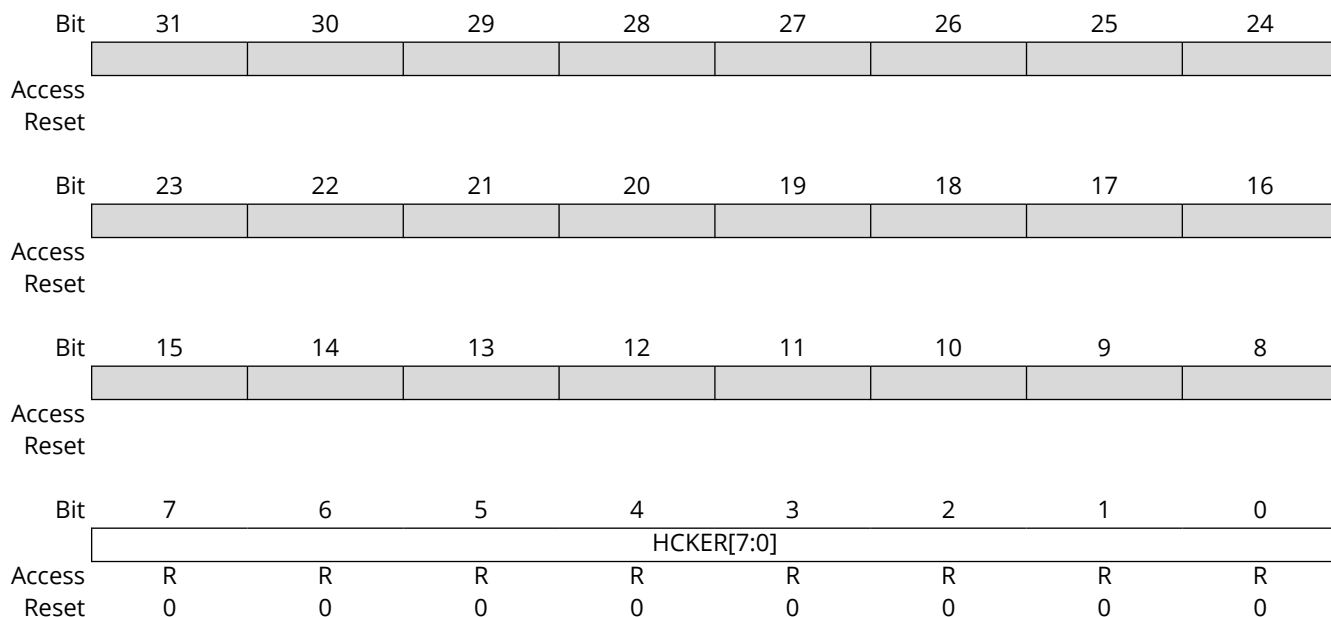
#### Bits 9:0 – RXOVR[9:0] Receive Overruns

This bit field counts the number of frames that are address recognized but were not copied to memory due to a receive overrun.



### 41.8.80 GMAC IP Header Checksum Errors Register

**Name:** IHCE  
**Offset:** 0x1A8  
**Reset:** 0x00000000  
**Property:** Read-only

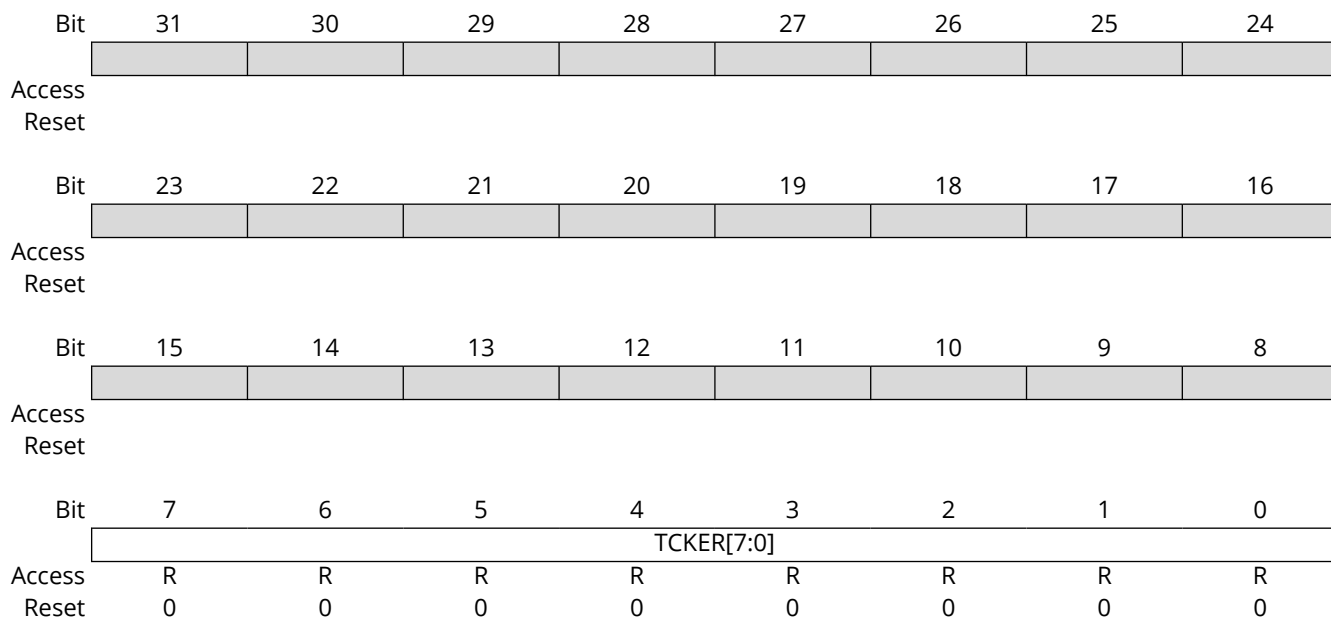


#### Bits 7:0 – HCKER[7:0] IP Header Checksum Errors

This register counts the number of frames discarded due to an incorrect IP header checksum, but are between 64 and 1518 Bytes (1536 Bytes if GMAC\_NCFGR.MAXFS=1) and do not have a CRC error, an alignment error, nor a symbol error.

### 41.8.81 GMAC TCP Checksum Errors Register

**Name:** TCE  
**Offset:** 0x1AC  
**Reset:** 0x00000000  
**Property:** Read-Only

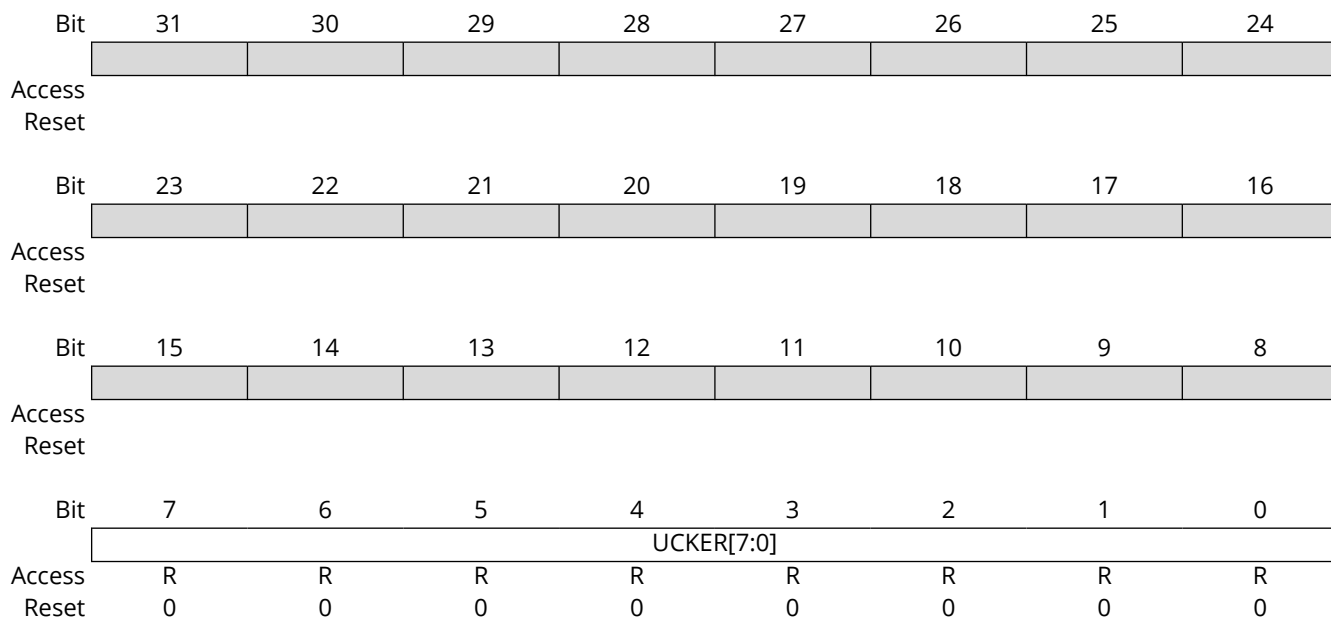


#### Bits 7:0 – TCKER[7:0] TCP Checksum Errors

This register counts the number of frames discarded due to an incorrect TCP checksum, but are between 64 and 1518 Bytes (1536 Bytes if NCFGR.MAXFS=1) and do not have a CRC error, an alignment error, nor a symbol error.

### 41.8.82 GMAC UDP Checksum Errors Register

**Name:** UCE  
**Offset:** 0x1B0  
**Reset:** 0x00000000  
**Property:** Read-Only



#### Bits 7:0 – UCKER[7:0] UDP Checksum Errors

This register counts the number of frames discarded due to an incorrect UDP checksum, but are between 64 and 1518 Bytes (1536 Bytes if NCFGR.MAXFS=1) and do not have a CRC error, an alignment error, nor a symbol error.

### 41.8.83 GMAC 1588 Timer Increment Sub-nanoseconds Register

**Name:** TISUBN  
**Offset:** 0x1BC  
**Reset:** 0x00000000  
**Property:** Read/Write

Bit	31	30	29	28	27	26	25	24
Access								
Reset								
Bit	23	22	21	20	19	18	17	16
Access								
Reset								
Bit	15	14	13	12	11	10	9	8
	LSBTIR[15:8]							
Access	R/W	R/W	R/W	R/W	R/W	R/W	R/W	R/W
Reset	0	0	0	0	0	0	0	0
Bit	7	6	5	4	3	2	1	0
	LSBTIR[7:0]							
Access	R/W	R/W	R/W	R/W	R/W	R/W	R/W	R/W
Reset	0	0	0	0	0	0	0	0

#### Bits 15:0 – LSBTIR[15:0] Lower Significant Bits of Timer Increment Register

Lower significant bits of Timer Increment Register [15:0], giving a 24-bit timer\_increment counter. These bits are the sub-ns value which the 1588 timer will be incremented each clock cycle. Bit n =  $2^{(n-16)}$  ns giving a resolution of approximately  $15.2E^{-15}$  sec.

#### 41.8.84 GMAC 1588 Timer Seconds High Register

**Name:** TSH  
**Offset:** 0x1C0  
**Reset:** 0x00000000  
**Property:** Read/Write

Bit	31	30	29	28	27	26	25	24
Access								
Reset								
Bit	23	22	21	20	19	18	17	16
Access								
Reset								
Bit	15	14	13	12	11	10	9	8
Access	TCS[15:8]							
Reset	0	0	0	0	0	0	0	0
Bit	7	6	5	4	3	2	1	0
Access	TCS[7:0]							
Reset	0	0	0	0	0	0	0	0

#### Bits 15:0 – TCS[15:0] Timer Count in Seconds

This register is writable. It increments by 1 when the IEEE 1588 nanoseconds counter counts to one second. It may also be incremented when the Timer Adjust Register is written.

### 41.8.85 GMAC 1588 Timer Seconds Low Register

**Name:** TSL  
**Offset:** 0x1D0  
**Reset:** 0x00000000  
**Property:** Read/Write

Bit	31	30	29	28	27	26	25	24
	TCS[31:24]							
Access	R/W	R/W	R/W	R/W	R/W	R/W	R/W	R/W
Reset	0	0	0	0	0	0	0	0
Bit	23	22	21	20	19	18	17	16
	TCS[23:16]							
Access	R/W	R/W	R/W	R/W	R/W	R/W	R/W	R/W
Reset	0	0	0	0	0	0	0	0
Bit	15	14	13	12	11	10	9	8
	TCS[15:8]							
Access	R/W	R/W	R/W	R/W	R/W	R/W	R/W	R/W
Reset	0	0	0	0	0	0	0	0
Bit	7	6	5	4	3	2	1	0
	TCS[7:0]							
Access	R/W	R/W	R/W	R/W	R/W	R/W	R/W	R/W
Reset	0	0	0	0	0	0	0	0

#### Bits 31:0 – TCS[31:0] Timer Count in Seconds

This register is writable. It increments by 1 when the IEEE 1588 nanoseconds counter counts to one second. It may also be incremented when the Timer Adjust Register is written.

### 41.8.86 1588 Timer Sync Strobe Seconds [31:0] Register

**Name:** TSSSL  
**Offset:** 0x1C8  
**Reset:** 0x00000000  
**Property:** Read/Write

Bit	31	30	29	28	27	26	25	24
	VTS[31:24]							
Access	R/W	R/W	R/W	R/W	R/W	R/W	R/W	R/W
Reset	0	0	0	0	0	0	0	0
Bit	23	22	21	20	19	18	17	16
	VTS[23:16]							
Access	R/W	R/W	R/W	R/W	R/W	R/W	R/W	R/W
Reset	0	0	0	0	0	0	0	0
Bit	15	14	13	12	11	10	9	8
	VTS[15:8]							
Access	R/W	R/W	R/W	R/W	R/W	R/W	R/W	R/W
Reset	0	0	0	0	0	0	0	0
Bit	7	6	5	4	3	2	1	0
	VTS[7:0]							
Access	R/W	R/W	R/W	R/W	R/W	R/W	R/W	R/W
Reset	0	0	0	0	0	0	0	0

#### Bits 31:0 – VTS[31:0] Value of Timer Seconds Register Capture

This register is writable. It increments by 1 when the IEEE 1588 nanoseconds counter counts to one second. It may also be incremented when the Timer Adjust Register is written.

### 41.8.87 GMAC 1588 Timer Sync Strobe Nanoseconds Register

**Name:** TSSN  
**Offset:** 0x1CC  
**Reset:** 0x00000000  
**Property:** Read/Write

Bit	31	30	29	28	27	26	25	24
			VTN[29:24]					
Access			R/W	R/W	R/W	R/W	R/W	R/W
Reset			0	0	0	0	0	0
Bit	23	22	21	20	19	18	17	16
	VTN[23:16]							
Access	R/W	R/W	R/W	R/W	R/W	R/W	R/W	R/W
Reset	0	0	0	0	0	0	0	0
Bit	15	14	13	12	11	10	9	8
	VTN[15:8]							
Access	R/W	R/W	R/W	R/W	R/W	R/W	R/W	R/W
Reset	0	0	0	0	0	0	0	0
Bit	7	6	5	4	3	2	1	0
	VTN[7:0]							
Access	R/W	R/W	R/W	R/W	R/W	R/W	R/W	R/W
Reset	0	0	0	0	0	0	0	0

#### Bits 29:0 – VTN[29:0] Value Timer Nanoseconds Register Capture

This register is writable. It increments by 1 when the IEEE 1588 nanoseconds counter counts to one second. It may also be incremented when the Timer Adjust Register is written.



### 41.8.88 GMAC 1588 Timer Nanoseconds Register

**Name:** TN  
**Offset:** 0x1D4  
**Reset:** 0x00000000  
**Property:** Read/Write

Bit	31	30	29	28	27	26	25	24
			TNS[29:24]					
Access			R/W	R/W	R/W	R/W	R/W	R/W
Reset			0	0	0	0	0	0
Bit	23	22	21	20	19	18	17	16
	TNS[23:16]							
Access	R/W	R/W	R/W	R/W	R/W	R/W	R/W	R/W
Reset	0	0	0	0	0	0	0	0
Bit	15	14	13	12	11	10	9	8
	TNS[15:8]							
Access	R/W	R/W	R/W	R/W	R/W	R/W	R/W	R/W
Reset	0	0	0	0	0	0	0	0
Bit	7	6	5	4	3	2	1	0
	TNS[7:0]							
Access	R/W	R/W	R/W	R/W	R/W	R/W	R/W	R/W
Reset	0	0	0	0	0	0	0	0

#### Bits 29:0 – TNS[29:0] Timer Count in Nanoseconds

This register is writable. It can also be adjusted by writes to the IEEE 1588 Timer Adjust Register. It increments by the value of the IEEE 1588 Timer Increment Register each clock cycle.

### 41.8.89 GMAC 1588 Timer Adjust Register

**Name:** TA  
**Offset:** 0x1D8  
**Reset:** 0x00000000  
**Property:** Write-Only

Bit	31	30	29	28	27	26	25	24
	ADJ		ITDT[29:24]					
Access	W		W	W	W	W	W	W
Reset	0		0	0	0	0	0	0
Bit	23	22	21	20	19	18	17	16
	ITDT[23:16]							
Access	W	W	W	W	W	W	W	W
Reset	0	0	0	0	0	0	0	0
Bit	15	14	13	12	11	10	9	8
	ITDT[15:8]							
Access	W	W	W	W	W	W	W	W
Reset	0	0	0	0	0	0	0	0
Bit	7	6	5	4	3	2	1	0
	ITDT[7:0]							
Access	W	W	W	W	W	W	W	W
Reset	0	0	0	0	0	0	0	0

**Bit 31 – ADJ** Adjust 1588 Timer  
Write as '1' to subtract from the 1588 timer. Write as '0' to add to it.

**Bits 29:0 – ITDT[29:0]** Increment/Decrement  
The number of nanoseconds to increment or decrement the IEEE 1588 Timer Nanoseconds Register. If necessary, the IEEE 1588 Seconds Register will be incremented or decremented.

## 41.8.90 GMAC IEEE 1588 Timer Increment Register

**Name:** TI  
**Offset:** 0x1DC  
**Reset:** 0x00000000  
**Property:** Read/Write

Bit	31	30	29	28	27	26	25	24
Access								
Reset								
Bit	23	22	21	20	19	18	17	16
	NIT[7:0]							
Access	R/W	R/W	R/W	R/W	R/W	R/W	R/W	R/W
Reset	0	0	0	0	0	0	0	0
Bit	15	14	13	12	11	10	9	8
	ACNS[7:0]							
Access	R/W	R/W	R/W	R/W	R/W	R/W	R/W	R/W
Reset	0	0	0	0	0	0	0	0
Bit	7	6	5	4	3	2	1	0
	CNS[7:0]							
Access	R/W	R/W	R/W	R/W	R/W	R/W	R/W	R/W
Reset	0	0	0	0	0	0	0	0

**Bits 23:16 – NIT[7:0]** Number of Increments  
The number of increments after which the alternative increment is used.

**Bits 15:8 – ACNS[7:0]** Alternative Count Nanoseconds  
Alternative count of nanoseconds by which the 1588 Timer Nanoseconds Register will be incremented each clock cycle.

**Bits 7:0 – CNS[7:0]** Count Nanoseconds  
A count of nanoseconds by which the IEEE 1588 Timer Nanoseconds Register will be incremented each clock cycle.

### 41.8.91 GMAC PTP Event Frame Transmitted Seconds Low Register

**Name:** EFTSL  
**Offset:** 0x1E0  
**Reset:** 0x00000000  
**Property:** Read-only

Bit	31	30	29	28	27	26	25	24
	RUD[31:24]							
Access	R	R	R	R	R	R	R	R
Reset	0	0	0	0	0	0	0	0
Bit	23	22	21	20	19	18	17	16
	RUD[23:16]							
Access	R	R	R	R	R	R	R	R
Reset	0	0	0	0	0	0	0	0
Bit	15	14	13	12	11	10	9	8
	RUD[15:8]							
Access	R	R	R	R	R	R	R	R
Reset	0	0	0	0	0	0	0	0
Bit	7	6	5	4	3	2	1	0
	RUD[7:0]							
Access	R	R	R	R	R	R	R	R
Reset	0	0	0	0	0	0	0	0

#### Bits 31:0 – RUD[31:0] Register Update

The register is updated with the value that the IEEE 1588 Timer Seconds Register holds when the SFD of a PTP transmit primary event crosses the MII interface. An interrupt is issued when the register is updated.

### 41.8.92 GMAC PTP Event Frame Transmitted Nanoseconds Register

**Name:** EFTN  
**Offset:** 0x1E4  
**Reset:** 0x00000000  
**Property:** Read-only

Bit	31	30	29	28	27	26	25	24
			RUD[29:24]					
Access			R	R	R	R	R	R
Reset			0	0	0	0	0	0
Bit	23	22	21	20	19	18	17	16
	RUD[23:16]							
Access	R	R	R	R	R	R	R	R
Reset	0	0	0	0	0	0	0	0
Bit	15	14	13	12	11	10	9	8
	RUD[15:8]							
Access	R	R	R	R	R	R	R	R
Reset	0	0	0	0	0	0	0	0
Bit	7	6	5	4	3	2	1	0
	RUD[7:0]							
Access	R	R	R	R	R	R	R	R
Reset	0	0	0	0	0	0	0	0

#### Bits 29:0 – RUD[29:0] Register Update

The register is updated with the value that the IEEE 1588 Timer Nanoseconds Register holds when the SFD of a PTP transmit primary event crosses the MII interface. An interrupt is issued when the bit field is updated.

### 41.8.93 GMAC PTP Event Frame Received Seconds Low Register

**Name:** EFRSL  
**Offset:** 0x1E8  
**Reset:** 0x00000000  
**Property:** Read-only

Bit	31	30	29	28	27	26	25	24
	RUD[31:24]							
Access	R	R	R	R	R	R	R	R
Reset	0	0	0	0	0	0	0	0
Bit	23	22	21	20	19	18	17	16
	RUD[23:16]							
Access	R	R	R	R	R	R	R	R
Reset	0	0	0	0	0	0	0	0
Bit	15	14	13	12	11	10	9	8
	RUD[15:8]							
Access	R	R	R	R	R	R	R	R
Reset	0	0	0	0	0	0	0	0
Bit	7	6	5	4	3	2	1	0
	RUD[7:0]							
Access	R	R	R	R	R	R	R	R
Reset	0	0	0	0	0	0	0	0

#### Bits 31:0 – RUD[31:0] Register Update

The register is updated with the value that the IEEE 1588 Timer Seconds Register holds when the SFD of a PTP receive primary event crosses the MII interface. An interrupt is issued when the register is updated.

#### 41.8.94 GMAC PTP Event Frame Received Nanoseconds Register

**Name:** EFRN  
**Offset:** 0x1EC  
**Reset:** 0x00000000  
**Property:** Read-only

Bit	31	30	29	28	27	26	25	24
			RUD[29:24]					
Access			R	R	R	R	R	R
Reset			0	0	0	0	0	0
Bit	23	22	21	20	19	18	17	16
	RUD[23:16]							
Access	R	R	R	R	R	R	R	R
Reset	0	0	0	0	0	0	0	0
Bit	15	14	13	12	11	10	9	8
	RUD[15:8]							
Access	R	R	R	R	R	R	R	R
Reset	0	0	0	0	0	0	0	0
Bit	7	6	5	4	3	2	1	0
	RUD[7:0]							
Access	R	R	R	R	R	R	R	R
Reset	0	0	0	0	0	0	0	0

##### Bits 29:0 – RUD[29:0] Register Update

The register is updated with the value that the IEEE 1588 Timer Nanoseconds Register holds when the SFD of a PTP receive primary event crosses the MII interface. An interrupt is issued when the register is updated.

### 41.8.95 GMAC PTP Peer Event Frame Transmitted Seconds Low Register

**Name:** PEFTSL  
**Offset:** 0x1F0  
**Reset:** 0x00000000  
**Property:** Read-Only

Bit	31	30	29	28	27	26	25	24
	RUD[31:24]							
Access	R	R	R	R	R	R	R	R
Reset	0	0	0	0	0	0	0	0
Bit	23	22	21	20	19	18	17	16
	RUD[23:16]							
Access	R	R	R	R	R	R	R	R
Reset	0	0	0	0	0	0	0	0
Bit	15	14	13	12	11	10	9	8
	RUD[15:8]							
Access	R	R	R	R	R	R	R	R
Reset	0	0	0	0	0	0	0	0
Bit	7	6	5	4	3	2	1	0
	RUD[7:0]							
Access	R	R	R	R	R	R	R	R
Reset	0	0	0	0	0	0	0	0

#### Bits 31:0 – RUD[31:0] Register Update

The register is updated with the value that the IEEE 1588 Timer Seconds Register holds when the SFD of a PTP transmit peer event crosses the MII interface. An interrupt is issued when the register is updated.



### 41.8.96 GMAC PTP Peer Event Frame Transmitted Nanoseconds Register

**Name:** PEFTN  
**Offset:** 0x1F4  
**Reset:** 0x00000000  
**Property:** Read-Only

Bit	31	30	29	28	27	26	25	24
			RUD[29:24]					
Access			R	R	R	R	R	R
Reset			0	0	0	0	0	0
Bit	23	22	21	20	19	18	17	16
	RUD[23:16]							
Access	R	R	R	R	R	R	R	R
Reset	0	0	0	0	0	0	0	0
Bit	15	14	13	12	11	10	9	8
	RUD[15:8]							
Access	R	R	R	R	R	R	R	R
Reset	0	0	0	0	0	0	0	0
Bit	7	6	5	4	3	2	1	0
	RUD[7:0]							
Access	R	R	R	R	R	R	R	R
Reset	0	0	0	0	0	0	0	0

#### Bits 29:0 – RUD[29:0] Register Update

The register is updated with the value that the 1588 Timer Nanoseconds Register holds when the SFD of a PTP transmit peer event crosses the MII interface. An interrupt is issued when the register is updated.

### 41.8.97 GMAC PTP Peer Event Frame Received Seconds Low Register

**Name:** PEFRSL  
**Offset:** 0x1F8  
**Reset:** 0x00000000  
**Property:** Read-Only

Bit	31	30	29	28	27	26	25	24
	RUD[31:24]							
Access	R	R	R	R	R	R	R	R
Reset	0	0	0	0	0	0	0	0
Bit	23	22	21	20	19	18	17	16
	RUD[23:16]							
Access	R	R	R	R	R	R	R	R
Reset	0	0	0	0	0	0	0	0
Bit	15	14	13	12	11	10	9	8
	RUD[15:8]							
Access	R	R	R	R	R	R	R	R
Reset	0	0	0	0	0	0	0	0
Bit	7	6	5	4	3	2	1	0
	RUD[7:0]							
Access	R	R	R	R	R	R	R	R
Reset	0	0	0	0	0	0	0	0

#### Bits 31:0 – RUD[31:0] Register Update

The register is updated with the value that the IEEE 1588 Timer Seconds Register holds when the SFD of a PTP receive primary event crosses the MII interface. An interrupt is issued when the register is updated.

### 41.8.98 GMAC PTP Peer Event Frame Received Nanoseconds Register

**Name:** PEFRN  
**Offset:** 0x1FC  
**Reset:** 0x00000000  
**Property:** Read-Only

Bit	31	30	29	28	27	26	25	24
			RUD[29:24]					
Access			R	R	R	R	R	R
Reset			0	0	0	0	0	0
Bit	23	22	21	20	19	18	17	16
	RUD[23:16]							
Access	R	R	R	R	R	R	R	R
Reset	0	0	0	0	0	0	0	0
Bit	15	14	13	12	11	10	9	8
	RUD[15:8]							
Access	R	R	R	R	R	R	R	R
Reset	0	0	0	0	0	0	0	0
Bit	7	6	5	4	3	2	1	0
	RUD[7:0]							
Access	R	R	R	R	R	R	R	R
Reset	0	0	0	0	0	0	0	0

#### Bits 29:0 – RUD[29:0] Register Update

The register is updated with the value that the IEEE 1588 Timer Nanoseconds Register holds when the SFD of a PTP receive primary event crosses the MII interface. An interrupt is issued when the register is updated.

### 41.8.99 Received LPI Transitions

**Name:** RLPITR  
**Offset:** 0x270  
**Reset:** 0x00000000  
**Property:** Read-Only

Bit	31	30	29	28	27	26	25	24
Access								
Reset								
Bit	23	22	21	20	19	18	17	16
Access								
Reset								
Bit	15	14	13	12	11	10	9	8
Access	RLPITR[15:8]							
Reset	0	0	0	0	0	0	0	0
Bit	7	6	5	4	3	2	1	0
Access	RLPITR[7:0]							
Reset	0	0	0	0	0	0	0	0

#### Bits 15:0 – RLPITR[15:0] Received LPI Transitions

The value of this bit field is a counter of transitions from receiving normal idle to receiving low power idle.

Cleared on read.

### 41.8.100 Received LPI Time

**Name:** RLPITI  
**Offset:** 0x274  
**Reset:** 0x00000000  
**Property:** Read-Only

Bit	31	30	29	28	27	26	25	24
Access								
Reset								
Bit	23	22	21	20	19	18	17	16
	RLPITI[23:16]							
Access	R	R	R	R	R	R	R	R
Reset	0	0	0	0	0	0	0	0
Bit	15	14	13	12	11	10	9	8
	RLPITI[15:8]							
Access	R	R	R	R	R	R	R	R
Reset	0	0	0	0	0	0	0	0
Bit	7	6	5	4	3	2	1	0
	RLPITI[7:0]							
Access	R	R	R	R	R	R	R	R
Reset	0	0	0	0	0	0	0	0

#### Bits 23:0 – RLPITI[23:0] Received LPI Time

The value of this bit field increments once every 16 AHB clock cycles when the Low Power Idle Enable bit in the Network Configuration Register (NCR.LPI) is written to '1'. Cleared on read.

### 41.8.101 Transmit LPI Transitions

**Name:** TLPITR  
**Offset:** 0x278  
**Reset:** 0x00000000  
**Property:** Read-Only

Bit	31	30	29	28	27	26	25	24
Access								
Reset								
Bit	23	22	21	20	19	18	17	16
Access								
Reset								
Bit	15	14	13	12	11	10	9	8
Access	TLPITR[15:8]							
Reset	TLPITR[15:8]							
Bit	7	6	5	4	3	2	1	0
Access	TLPITR[7:0]							
Reset	TLPITR[7:0]							

#### Bits 15:0 – TLPITR[15:0] Transmit LPI Transitions

A count of the number of times the Low Power Idle Enable bit in the Network Configuration Register (NCR.LPI) goes from '0' to '1'.

### 41.8.102 Transmit LPI Time

**Name:** TLPITI  
**Offset:** 0x27C  
**Reset:** 0x00000000  
**Property:** Read-Only

Bit	31	30	29	28	27	26	25	24
Access								
Reset								
Bit	23	22	21	20	19	18	17	16
	TLPITI[23:16]							
Access	R	R	R	R	R	R	R	R
Reset	0	0	0	0	0	0	0	0
Bit	15	14	13	12	11	10	9	8
	TLPITI[15:8]							
Access	R	R	R	R	R	R	R	R
Reset	0	0	0	0	0	0	0	0
Bit	7	6	5	4	3	2	1	0
	TLPITI[7:0]							
Access	R	R	R	R	R	R	R	R
Reset	0	0	0	0	0	0	0	0

#### Bits 23:0 – TLPITI[23:0] Transmit LPI Time

The value of this bit field increments once every 16 AHB clock cycles when the Low Power Idle Enable bit in the Network Configuration Register (NCR.LPI) is written to '1'. Cleared on read.

## 42. Position Decoder (PDEC)

### 42.1 Overview

The PDEC consists of a Quadrature or Hall decoder, following by a counter, with two compare channels. The counter can be divided into two parts to report the angular position and the number of revolutions. If the quadrature decoder feature is not suitable for specific applications, the PDEC module can be used as an additional time base.

### 42.2 Features

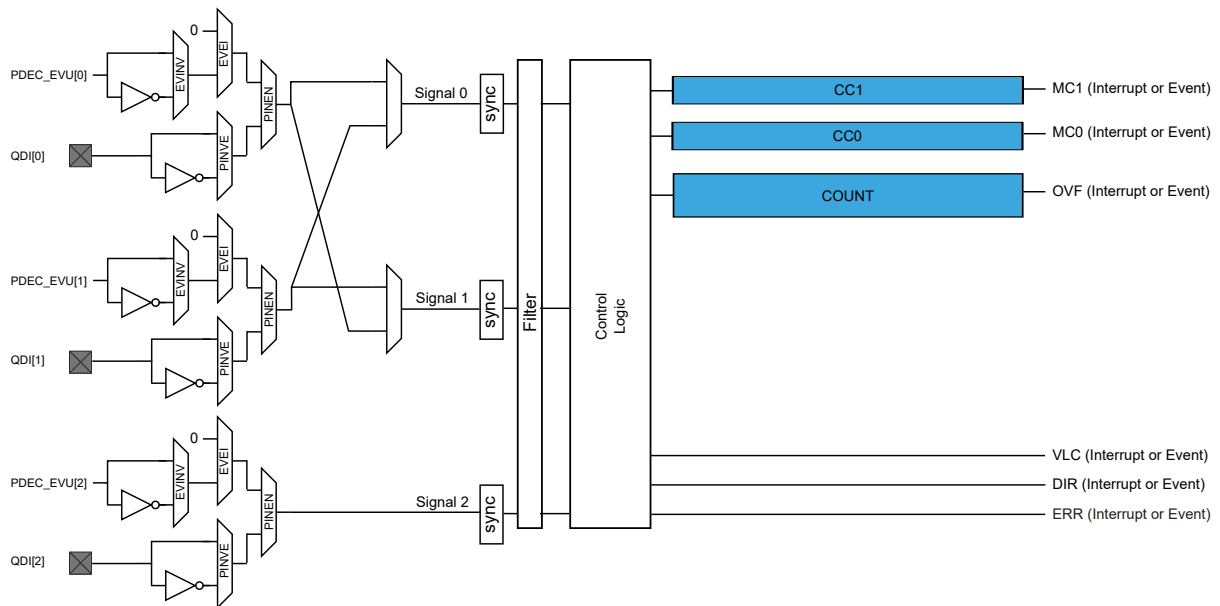
The following are key features of the PDEC module:

- Internal prescaler
- Selectable mode of operation:
  - QDEC, HALL, or COUNTER
- QDEC
  - Angular and revolution counts
  - Synchronous and asynchronous velocity measurements
  - Direction change detection
  - Check valid quadrature transitions
  - Check index position versus angular position
  - Auto correction mode
- HALL
  - Window validation of Hall transitions
  - Hall code detection
  - Direction change detection
  - Check valid Hall transitions
  - Programmable event generation delay after a Hall transition
- COUNTER
  - 16-bit counter with two compare channels
  - One of the compare channels can be configured with period settings
  - Counter overflow interrupt and event generation option
  - Compare match interrupt and event generation option



## 42.3 Block Diagram

Figure 42-1. Block Diagram



## 42.4 Signal Description

Signal Name	Type	Description
PDEC[2:0]	Digital input	PDEC inputs



I/Os for PDEC peripheral are grouped into I/O sets, listed in their `IOSET' column in the pinout tables. For these peripherals, it is mandatory to use I/Os that belong to the same I/O set. The timings are not guaranteed when I/Os from different I/O sets are mixed. Refer to the [Pinout and Packaging](#) chapter to get IOSET definitions.

## 42.5 Peripheral Dependencies

<b>Peripheral Name</b>	PDEC – Position Decoder
<b>Base Address</b>	0x4200_1C00 (Peripheral Bus C)
<b>NVIC IRQ Index:Source</b>	115 : DIR, ERR, OVF, VLC; 116 : MC0; 117 : MC1
<b>MCLK APB Clock (1)</b>	CLK_PDEC_APB, Disabled, APBCMASK.PDEC
<b>GCLK Peripheral Channel Index:Clock Name (2)</b>	31 : GCLK_PDEC
<b>PAC Peripheral Peripheral Identifier (PAC.WRCTRL)</b>	71
<b>DMA Trigger Index:Source (DMAC.CHCTRLA,k=0,1,...31)</b>	n/a
<b>EVSYS Users (EVSYS.USERm) (3)</b>	52-54 : PDEC Input Event x, x=0..2 (PDEC_EVU 0..2) (A,S,R)
<b>EVSYS Generators (EVSYS.CHANNELn)</b>	97 : Overflow/Underflow (PDEC_OVF) 98 : Error (PDEC_ERR) 99 : Direction (PDEC_DIR) 100 : Velocity (PDEC_VLC) 101,102 : Channel x Compare, x=0..1 (PDEC_MCx)

**Notes:**

1. Clock Name, Default State, Mask Field.
2. See GCLK.PCHCTRLm Register, where m = Index.
3. (A,S,R): A = Asynchronous path, S = Synchronous path, R = Resynchronized path.

#### 42.5.1 Power Management

The PDEC can be configured to operate in any sleep mode. The PDEC can wake up the device using interrupts from any sleep mode or perform actions through the [Event System](#).

#### 42.5.2 Clocks

A generic clock (GCLK\_PDEC) is required to clock the PDEC. This clock must be configured and enabled in the [Generic Clock Controller](#) before using the PDEC.

This generic clock is asynchronous to the bus clock (CLK\_PDEC\_APB). Due to this asynchronicity, writes to certain registers will require synchronization between the clock domains.

#### 42.5.3 Debug Operation

When CPU is halted in Debug mode, the PDEC will halt normal operation. The PDEC can be forced to continue operation during debugging. Refer to [DBGCTRL](#) register for additional information.

#### 42.5.4 Register Access Protection

All registers with write access can be write-protected optionally by the [Peripheral Access Controller \(PAC\)](#), except for the following registers:

- The Interrupt Flag register (INTFLAG)
- The Filter register (FILTER)
- The Prescaler register (PRESC)
- The Compare x Value register (CCx)
- The Channel x Compare Buffer Value register (CCBUFx)
- The Status register (STATUS)

Optional write protection by the [Peripheral Access Controller \(PAC\)](#) is denoted by the "PAC Write Protection" property in each individual register description.

The PAC write protection does not apply to accesses through an external debugger.

## 42.6 Functional Description

### 42.6.1 Principle of Operation

The PDEC control logic can be driven by a set of three inputs signal coming from Event System channels or I/O input pins. These three inputs can be filtered prior to down-stream processing. The input polarity, phase definition and other factors are configurable. QDEC, HALL or COUNTER mode of operation are supported.

Depending of the mode configuration, specific input sequences can generate:

- State change
- Counter increment or decrement
- Interrupts
- Output events

### 42.6.2 Basic Operation

#### 42.6.2.1 Initialization

The following PDEC registers are enable-protected, meaning they can only be written when the PDEC is disabled (CTRLA.ENABLE is zero):

- Event Control register (EVCTRL)

Enable-protected bits in the CTRLA register can be written at the same time as CTRLA.ENABLE is written to '1', but not at the same time as CTRLA.ENABLE is written to '0'.

Enable-protection is denoted by the 'Enable-Protected' property in the register description.

#### 42.6.2.2 Enabling, Disabling, and Resetting

The PDEC must be configured before it is enabled by the following steps:

1. Enable the PDEC bus clock (CLK\_PDEC\_APB)
2. Select the mode of operation by writing the Mode bits in the Control A register (CTRLA.MODE)
3. Select the PDEC mode configuration by writing the Configuration bits in the Control A register (CTRLA.CONF)
4. Select the PDEC event or pin input signal source by writing the Event Enable Input bit in the Event Control register (EVCTRL.EVEI) or by the Pin Enable bit in Control A register (CTRLA.PINEN)
5. Select the angular counter length value by writing the Angular bits in the Control A register (CTRLA.ANGULAR)

Optionally, the following configurations can be set before enabling PDEC:

- The GCLK\_PDEC clock can be prescaled by writing to the Prescaler register (PRESC)
- A filter can be applied to the input signal by writing a corresponding value to the Filter register (FILTER)
- If the resolution of the rotary sensor is not a power of 2, an Angular period can be set (CTRLA.PEREN and CC0 register)

The PDEC is enabled by writing a '1' to the Enable bit in the Control A register (CTRLA.ENABLE). The PDEC is disabled by writing a '0' to CTRLA.ENABLE.

In QDEC or HALL operation modes, PDEC decoding is enabled writing a START command in the Control B Set register (CTRLBSET.CMD=START). The PDEC decoding is disabled writing a STOP command in the Control B Set register (CTRLBSET.CMD=STOP).

The PDEC is reset by writing a '1' to the Software Reset bit in the Control A register (CTRLA.SWRST). All registers in the PDEC, except DBGCTRL, will be reset to their initial state, and the PDEC will be disabled.

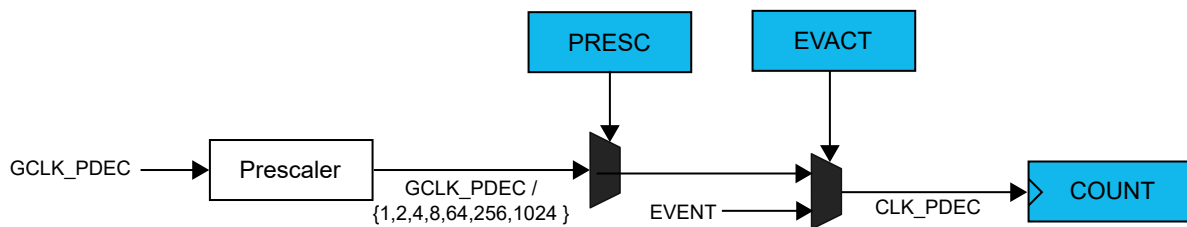
The PDEC should be disabled before the PDEC is reset to avoid undefined behavior.

### 42.6.2.3 Prescaler Selection

The GCLK\_PDEC is fed into the internal prescaler. Prescaler outputs from 1 to 1/1024 are directly available for selection by the counter and all selections are available in Prescaler register (PRESC). If the prescaler value is higher than 0x01, the counter update condition is executed on the next prescaled clock pulse.

The prescaler clock is also enabled when the input filtering is required.

Figure 42-2. Prescaler Selection



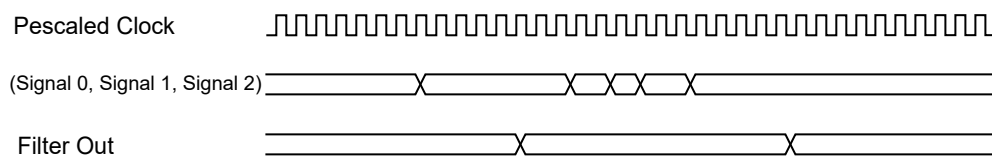
### 42.6.2.4 Input Selection and Filtering

The QDEC and HALL operations require three inputs, as shown in the [Block Diagram](#). Each input can either be a dedicated I/O pin or an Event system channel. This is selected by writing to the corresponding Event x Enable bit in the Event Control register (EVCTRL.EVEIx) or Pin x Enable bit in the Control A register (CTRLA.PINENx).

The I/O input pin active level can be inverted by writing to the corresponding Pin x Inversion Enable bit in Control A register (CTRLA.PINVENx). In the same way, the event input active level can be inverted by writing to the corresponding Inverted Event x Input Enable bit in Event Control register (EVCTRL.EVINVx).

All input signals can be filtered before they are fed into the control logic. The FILTER register is used to configure the minimum duration for which the input signal has to be valid. The input signal minimum duration must be  $(FILTER+1) * t_{GCLK\_PDEC}$ .

Figure 42-3. Input Signal Filtering



Only the first two input signals can be swapped by writing to the SWAP bit in the Control A register (CTRLA.SWAP).

### 42.6.2.5 Period Control

The Channel Compare 0 register (CC0) can act as a period register (PER) by writing the PEREN bit in the Control A register (CTRLA.PEREN) to '1'. The PER can be used to control the top value (TOP) of the counting operation:

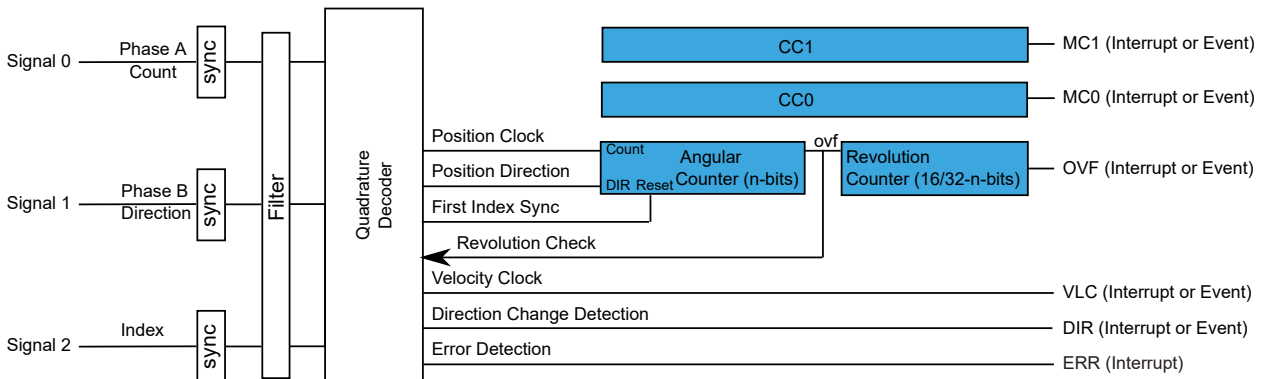
When up-counting and the counter reaches the value of CC0, the counter is cleared to zero. When down-counting and the counter reaches zero, the counter is reloaded with the CC0 value.

### 42.6.2.6 QDEC Operation Mode

In QDEC mode of operation, Signal 0 and Signal 1 control logic inputs refer to Phase A and Phase B in X4 mode, and to count/direction in X2 mode. The Signal 2 control logic input refers to the Index, in

both X4 and X2 mode of operation. In X4 mode, a simultaneous transition on Phase A and Phase B will cause a QDEC error detection (STATUS.QERR).

**Figure 42-4.** QDEC Block Diagram



#### 42.6.2.6.1 Position and Rotation Measurement

After filtering, the quadrature signals are analyzed to extract the rotation direction and edges in order to be counted by the counter.

The counter is split in two parts. The LSB part of the counter is used as Angular counter. The Phase A and B define the motor displacement direction, which define the Angular and Revolution counting direction.

The Index can be enabled in two different ways:

- Set the PINEN[2] bit in the Control A register (CTRLA.PINEN[2]) if the Index is provided by the PIN2 IO pin directly.
- Set the EVEI[2] bit in Event Control register (EVCTRL.EVEI[2]) if the INDEX is provided by a channel connected to the Event System.
- If the signal polarity must be inverted, the user must program the PINVEN[2] in Control A register (CTRLA.PINVEN[2]) or EVINV[2] in Event Control register (EVCTRL.EVINV[2])

A valid Index is qualified with the two other inputs (PhaseA, PhaseB) at low level.

Each counter has a TOP value, defined as follows:

- If the Period is disabled (CTRLA.PEREN = 0), the TOP value for each counter represents the MAX value (all bit are one).
- If the Period is enabled (CTRLA.PEREN = 1), the Angular counter TOP value is the CC0 LSB portion, and the Revolution counter TOP value is the CC0 MSB portion. For additional information, refer to CTRLA.ANGULAR settings.

The "Signal 0" and "Signal 1" (refer to Figure 2-1 for details) edge detections define the motor axis position, which increments or decrements the Angular counter. The Angular counter will count up or down, depending on the counting direction. The counter is reloaded with its TOP or ZERO value depending on counting direction.

When the Index detection is disabled, the Angular counter is reloaded with its TOP or ZERO, depending on counter direction only, when the overflow (angular counter equals its TOP) or underflow (angular counter equals zero) conditions are met.

- When the counter is counting up and its TOP value is reached, the counter will be reloaded with ZERO value on the next tick (overflow) and the Overflow Interrupt Flag in the Interrupt Flag Status and Clear register (INTFLAG.OVF) will be set.

- When the counter is counting down and ZERO is reached, the counter will be reloaded with its TOP value on the next tick (underflow), and the INTFLAG.OVF will be set. The INTFLAG.OVF can be used to trigger an interrupt or an event.

When the Index is enabled, additional actions will occur, depending on the operating configuration (CTRLA.CONF):

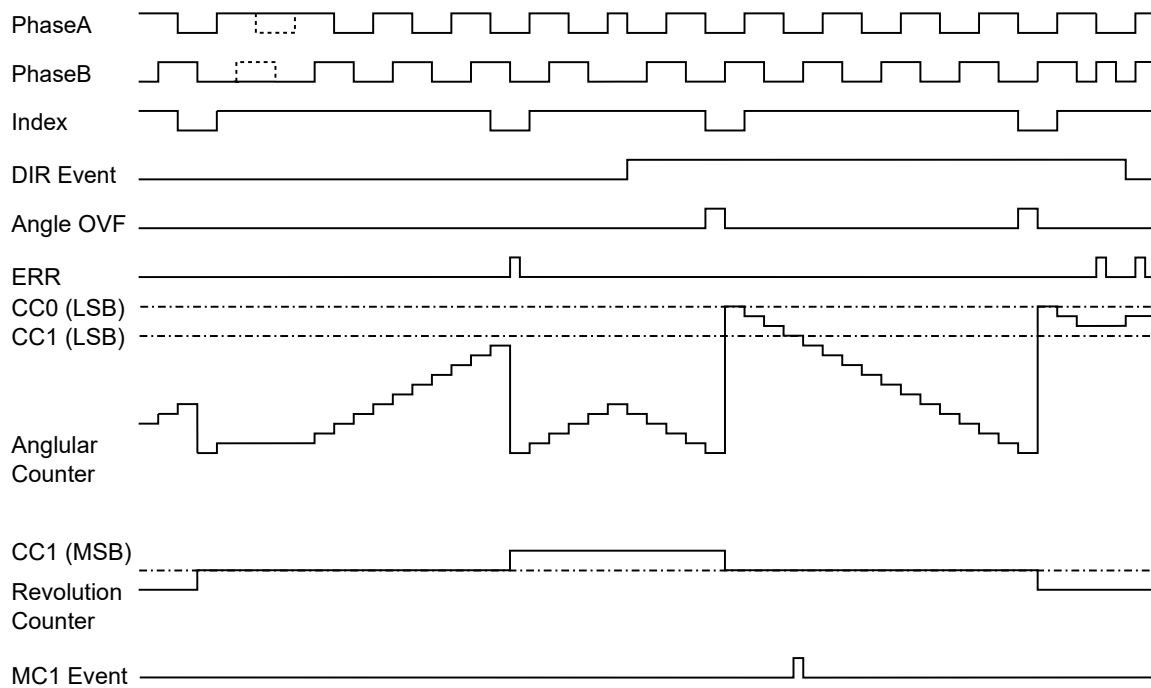
- In X2 and X4 configuration operating mode:
  - When the counter is counting up, a valid Index detection will reload the counter with ZERO value
  - When the counter is counting down, a valid Index detection will reload the counter with its TOP value
- In X2S and X4S configuration operating mode:
  - The first valid Index detection after the module is enabled, will reload the counter with ZERO value
  - Any other valid Index detection which does not match the Angular counter overflow or underflow, will set the Index Error flag in the Status register (STATUS.IDXERR). The Error Interrupt Flag is set (INTFLAG.ERR) and an optional interrupt can be generated.

The Revolution counter will count up or down, depending on the counting direction and configuration modes:

- In X2 and X4 configuration operating mode:
  - If the Index is enabled, the counter is incremented (or decremented depending on counting direction) on each index detection.
  - If the Index is disabled, the counter is incremented (or decremented depending on counting direction) on each Angular counter overflow/underflow
- In X2S and X4S configuration operating mode, the counter is incremented (or decremented depending on counting direction) on each Angular counter overflow/underflow
  - If the Index is not detected after one Angular counter revolution, the Index Error flag in Status register (STATUS.IDXERR) is set. The Error Interrupt Flag is set (INTFLAG.ERR) and an optional interrupt can be generated.

When counting-up and its TOP value is reached, the Channel 0 Compare Match Interrupt Flag in the Interrupt Flag Status and Clear register (INTFLAG.MC0) will be set. When counting-down and ZERO is reached, the INTFLAG.MC0 will be set. The Channel 0 Compare Match condition can be enabled as source of interrupt or event generation.

**Figure 42-5.** Position and Rotation Measurement



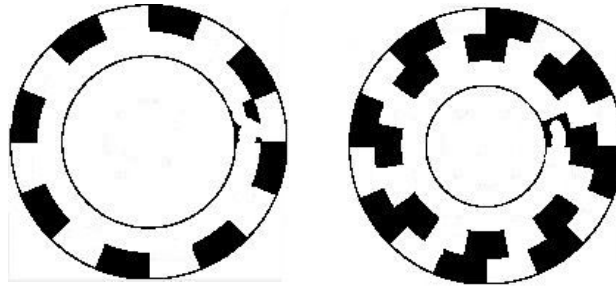
#### 42.6.2.6.2 Secure Decoder Detection

Position decoders are generally implemented using external photo-detectors, detecting a transmitted or reflected beam. Error detections or no detections may happen, and are due to:

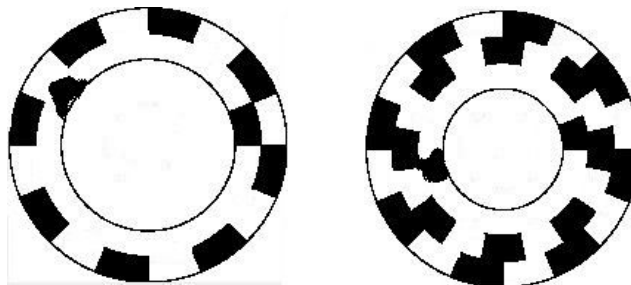
- A transmitted beam locally stopped by a dust
- A reflected beam lost by a mat dust
- An additional parasitic reflected beam, due to a gloss metallic dust

Figure 42-6. Coding Wheels Error Types

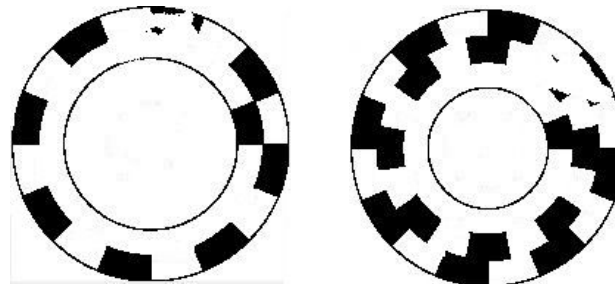
**Type 1 Error: Missing Index Detection**



**Type 2 Error: Extra Index Detection**



**Type 3 Error: Missing Angular Step Detection**

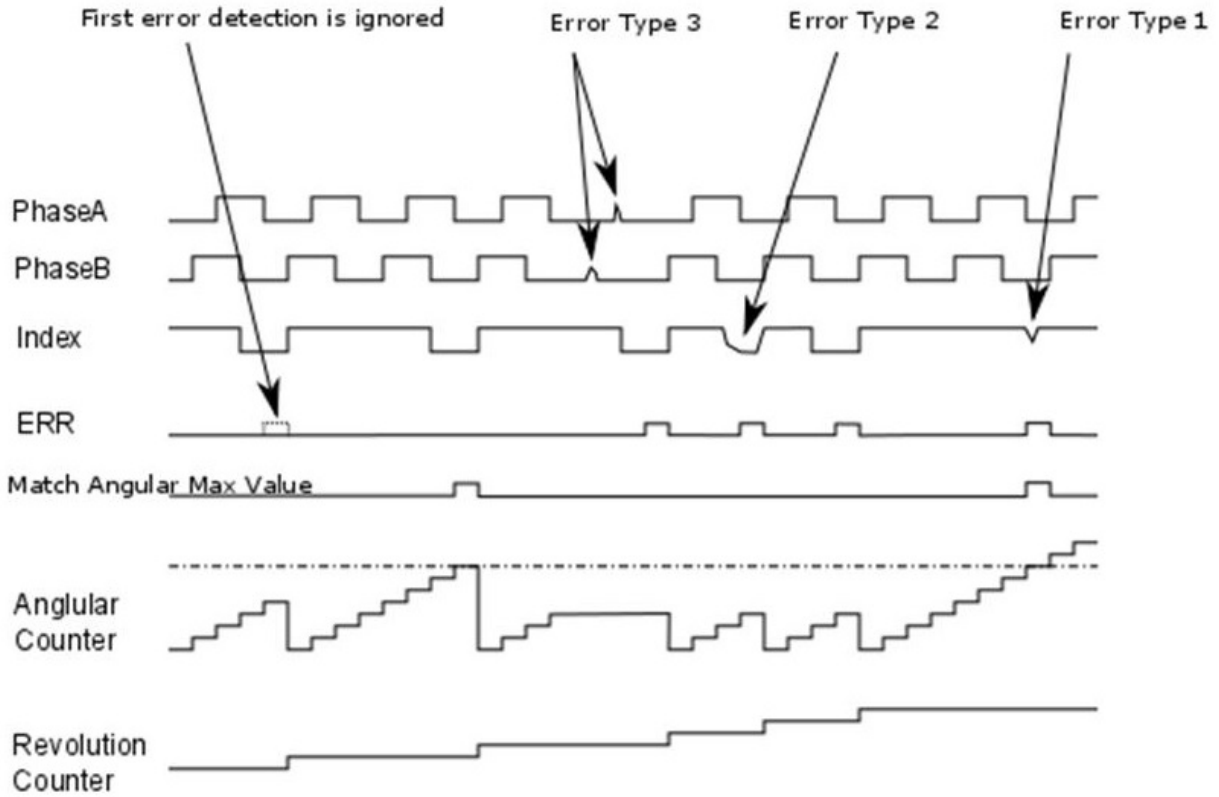


When secure detection is enabled ( $CTRLA.CONF = X4S$  or  $CTRLA.CONF = X2S$ ), the Index must be enabled. The Angular counter is restarted on the detection of each overflow. When the Angular counter value reaches its maximum period value (TOP), an Index is expected to be detected. In the same way, if the Index is detected, the Angular counter value is expected to be TOP. If one of these conditions is not met, an error is generated.

**Note:** The first error generation is masked, as the initial position of the wheel is in unknown state. The first index is used to synchronize the Angular counter on Revolution counter increment.



Figure 42-7. Secure Decoder Detections



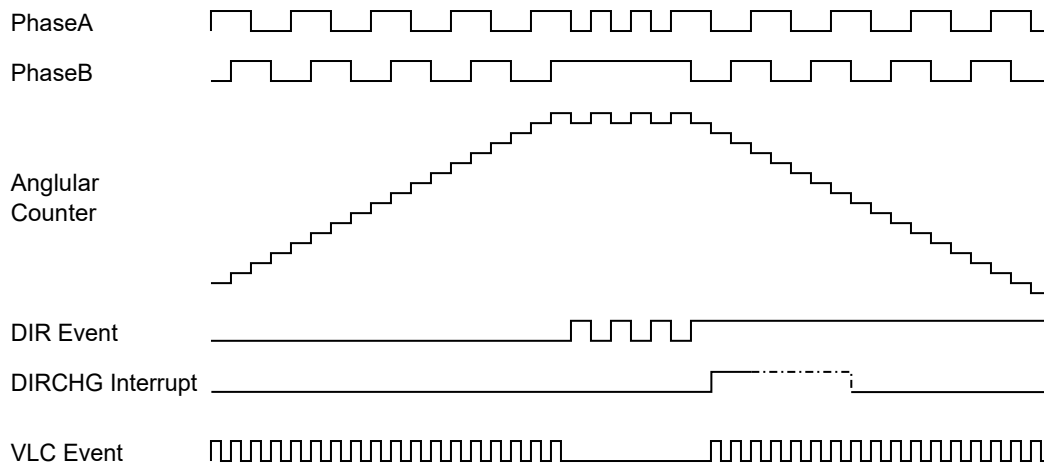
#### 42.6.2.6.3 Direction Status and Change Detection

The direction (DIR) status can be directly read anytime in the STATUS register (STATUS.DIR). The polarity of the direction flag status depends of the input signal swap and active level configuration.

Each time a rotation direction change is detected, the Direction Change Interrupt Flag is set (INTFLAG.DIR) and an optional interrupt can be generated. The same interrupt condition is source of Direction event output.

**Note:** STATUS.DIR bit status is not relevant if a direction change occurs (INTFLAG.DIR=1).

Figure 42-8. Rotation Direction Change



To avoid spurious interrupts when coding wheel is stopped, the direction change condition is reported as an interrupt, only on the second edge confirming the direction change.

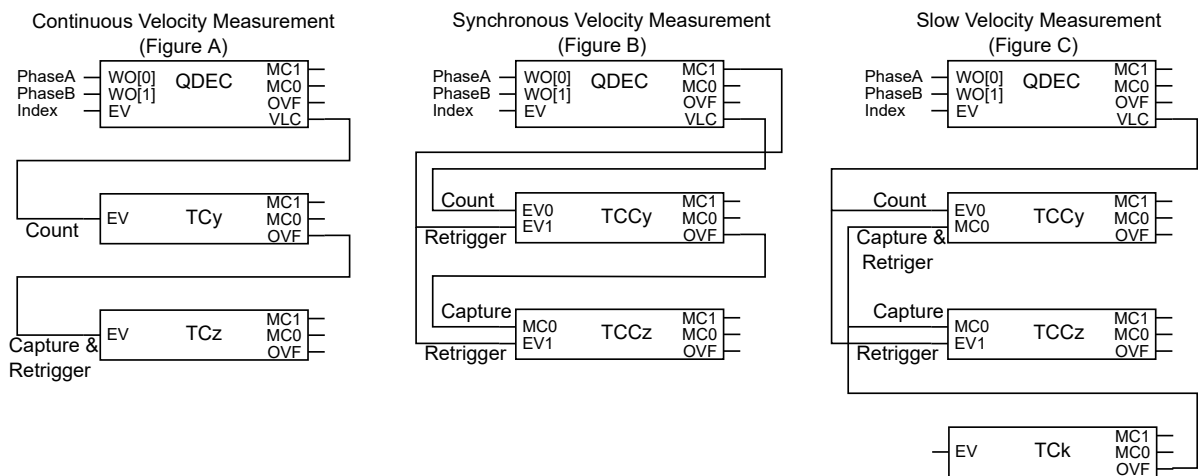
Velocity output event is generated on each QDEC transition except when the direction changes.

#### 42.6.2.6.4 Speed Measurement

Three types of speed measurement can be done using velocity event output (VLC) and Timer/Counter (TC/TCC) device resources.

- Continuous velocity measurement: TCz measures the time on which n VLC (TCy) output events occur
- Synchronous Velocity measurement: On a specific motor position TCCz, the time is measured on which n VLC (TCCy) output events occur.
- Slow Velocity measurement: measure the number of VLC output events (TCCy) plus the delay since the last VLC output event (TCCz) within a given time slot (Tck).

Figure 42-9. Speed Measurement



#### 42.6.2.6.5 Missing Pulse Detection and Auto-Correction

The PDEC embeds circuitry to detect and correct errors that may result from contamination on optical disks or other sources producing quadrature phase signals.

The auto-correction works in QDEC X4 mode only. A missing pulse on a phase signal is automatically detected, and the pulse count reported in the Angular part of COUNT is automatically corrected.

There is no autocorrection if both phase signals are affected at the same location on the input signals, because the autocorrection requires a valid phase signal to detect contamination on the other phase signal.

If the quadrature source is undamaged, the number of pulses counted for a predefined period of time must be the same with or without detection and auto-correction. Therefore, if the measurement results differ, a contamination exists on the source producing the quadrature signals. This does not substitute the measurements of the number of pulses between two index pulses (if available) but provides an additional method to detect damaged quadrature sources.

When the source providing quadrature signals is strongly damaged, potentially leading to a number of consecutive missing pulses greater than 1, the quadrature decoder processing may be affected.

The Maximum Consecutive Missing Pulses bits in Control A register (CTRLA.MAXCMP) define the maximum acceptable number of consecutive missing pulses. If the limit is reached, the Missing Pulse Error flag in Status register (STATUS.MPERR) is set. The Error Interrupt flag is set (INTFLAG.ERR) and an optional interrupt can be generated.

**Note:** When the MAXCMP value is zero, the MPERR error flag is never set.

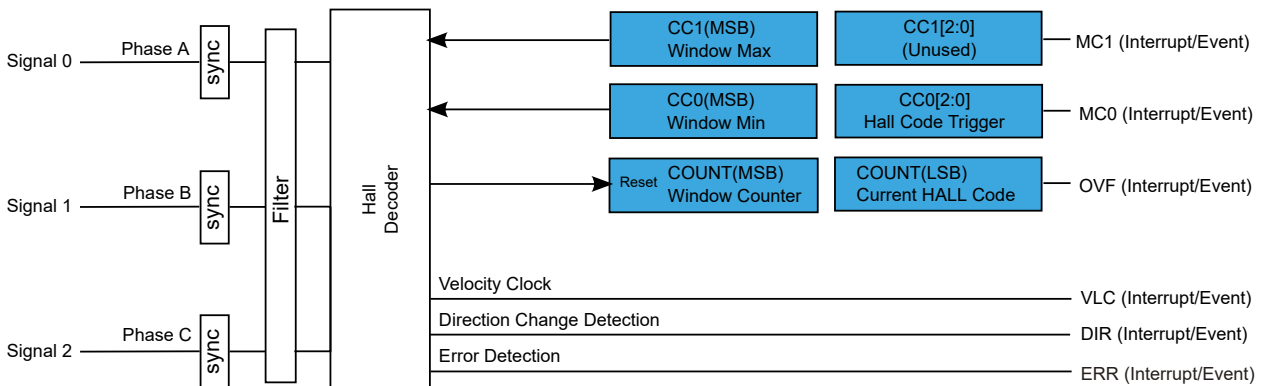
### 42.6.3 Additional Features

#### 42.6.3.1 HALL Operation Mode

In HALL operation mode, control logic signal 0, 1 and 2 inputs represent the phase A, B and C of a Hall sensor, respectively.

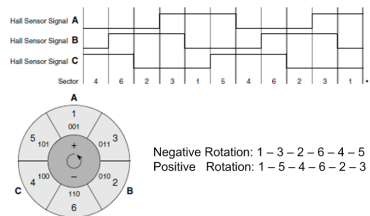
A programmable delayed event can be generated to update a TCC pattern generator.

**Figure 42-10.** HALL Block Diagram



When positive rotation is detected, the DIR status bit is set (STATUS.DIR = 1). When a negative rotation sequence is detected, the DIR status bit is set (STATUS.DIR = 0).

**Figure 42-11.** HALL States Overview



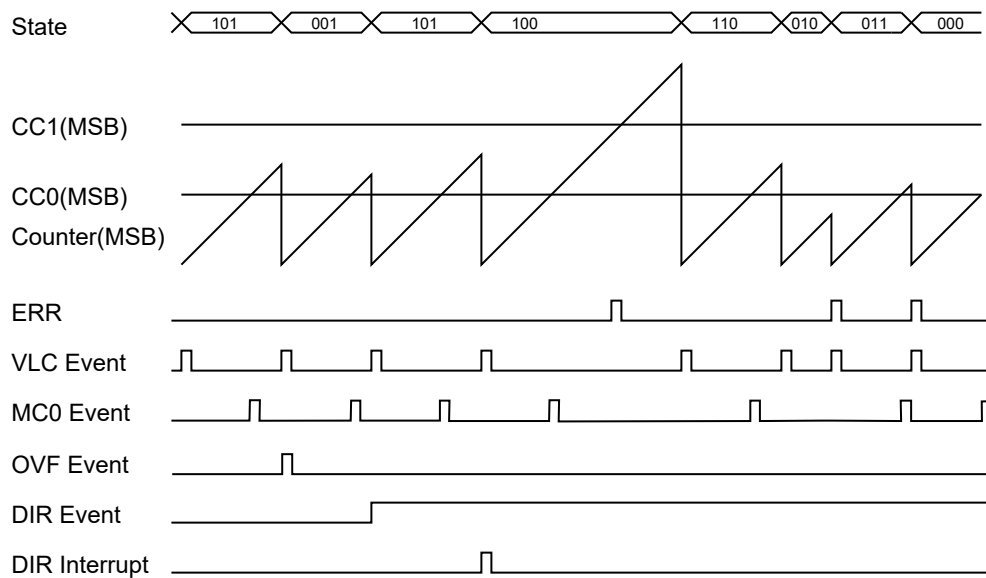
#### 42.6.3.1.1 Hall Sensor Control

On any update of the filter output:

- The filter output value is checked to be a valid Hall value. If an invalid Hall code is reported, the Hall Error bit in the Status register will be set (STATUS.HERR).
- The OVF Interrupt Flag bit is set (INTFLAG.OVF) if CC0[2:0] matches the filter output value, stored in LSB part of the COUNTER. An optional overflow interrupt or Event output is generated on the same condition detection.
- The window counter is checked to be between the value of the MSB part of CC0 and CC1, and reset to 0 value. If an error is detected, the Window Error bit in the Status register (STATUS.WINERR) is set.
- The delay counter is started, and MC0 optional interrupt or event is generated when the delay counter matches the MSB part of CC0.
- Optional MC1 interrupt or event is generated when the delay counter matches the MSB part of CC1.

Any error condition will set the Error Interrupt Flag (INTFLAG.ERR). An optional interrupt or event output is generated on the same condition detection.

Figure 42-12. Hall Waveforms



### 42.6.3.2 Counter Operation Mode

Depending on the mode of operation, the counter (Counter Value register COUNT) is cleared, reloaded, or incremented at each counter clock input.

The counter will count for each clock tick until it reaches TOP. When TOP is reached, the counter will be set to zero on the next clock input.

This comparison will set the Overflow Interrupt Flag in the Interrupt Flag Status and Clear register (INTFLAG.OVF) and can be used to trigger an interrupt or an event.

It is possible to change the counter value when the counter is running. The write access has higher priority than count, or clear. The COUNT value will always be zero when starting the PDEC, unless a different value has been written to it, or the PDEC has been disabled at a value other than zero. Due to asynchronous clock domains, the internal counter settings are written once the synchronization is complete.

### 42.6.3.3 Register Lock Update

Prescaler (PRESC), FILTER, and CCx registers are buffered (PRESCBUF, FILTERBUF, CCBUFx registers, respectively). When a new value is written in a buffer register, the corresponding Buffer Valid bit is set in the Buffer Status register (STATUS.FILTERBUFV, STATUS.PRESCBUFV, STATUS.CCBUFVx).

By default, a register is updated with the its buffer register's value on UPDATE condition, which represents:

- The next filter transition in QDEC and HALL mode of operation
- The overflow/underflow or re-trigger event detection in COUNT mode of operation

The buffer valid flags in the STATUS register are automatically cleared by hardware when the data is copied from the buffer to the corresponding register.

It is possible to lock the updates by writing a '1' to the Lock Update bit in Control B Set register (CTRLBSET.LUPD).

The lock feature is disabled by writing a '1' to the Lock Update bit in Control B Clear register (CTRLBCLR.LUPD). When a buffer valid status flag is '1' and updating is not locked, the data from the buffer register will be copied into the corresponding register on UPDATE condition.

It is also possible to modify the LUPD bit behavior by hardware, by writing a '1' to the Auto-lock bit in Control A register (CTRLA.ALOCK). When the bit is '1', the Lock Update bit in Control B register (CTRLBSET.LUPD) is set when the UPDATE condition is detected.

#### 42.6.3.4 Software Command and Event Actions

The PDEC peripheral supports software commands and event actions. The software commands are applied by the Software Command bit field in the Control B register (CTRLBSET.CMD, CTRLBCLR.CMD). The event actions are available in the Event Action bit-field in Event Control register (EVCTRL.EVACT).

##### 42.6.3.4.1 Re-trigger Software Command or Event Action

A re-trigger command can be issued from software by using PDEC Command bits in Control B Set register (CTRLBSET.CMD = RETRIGGER).

When the re-trigger command is detected during counting operation, the counter will be reloaded or cleared, depending on the counting direction (DIR). If the re-trigger command is detected when the counter is stopped, the counter will resume counting operation from the value in the COUNT register.

##### 42.6.3.4.2 Force Update Software Command

A Force Update command can be issued by writing the PDEC Command bits in Control B Set register (CTRLBSET.CMD = UPDATE). When the command is issued, the buffered registers will be updated.

##### 42.6.3.4.3 Force Read Synchronization Software Command

A Force Read Synchronization command can be issued writing the PDEC Command bits in Control B Set register (CTRLBSET.CMD = READSYNC). When the command is issued, a COUNT register read synchronization is forced.

**Note:** This command should be used to read the most updated COUNT internal value.

#### 42.6.4 Interrupts

The PDEC has the following interrupt sources:

- Overflow/Underflow: OVF
- Compare Channels: COMPx
- Error: ERR
- Velocity: VLC. This interrupt is available only in QDEC and HALL operation modes.
- Direction: DIR. This interrupt is available only in QDEC and HALL operation modes.

Each interrupt source has an interrupt flag associated with it. The interrupt flag in the Interrupt Flag Status and Clear register (INTFLAG) is set when the interrupt condition occurs. Each interrupt can be individually enabled by writing a '1' to the corresponding bit in the Interrupt Enable Set register (INTENSET), and disabled by writing a '1' to the corresponding bit in the Interrupt Enable Clear register (INTENCLR).

An interrupt request is generated when the interrupt flag is set and the corresponding interrupt is enabled. The interrupt request remains active until the interrupt flag is cleared, the interrupt is disabled or the PDEC is reset. See the [INTFLAG](#) register description for details on how to clear interrupt flags.

The user must read the INTFLAG register to determine which interrupt condition is present.

**Note:** Interrupts must be globally enabled for interrupt requests to be generated. See the [Nested Vector Interrupt Controller](#) for details.

#### 42.6.5 Events

The PDEC can generate the following output events:

- Overflow/Underflow: OVF

- Channel x Compare Match: MCx
- Error: ERR
- Velocity: VLC. This interrupt is available only in QDEC and HALL operation modes.
- Direction: DIR. This interrupt is available only in QDEC and HALL operation modes.

Writing a '1' to an Event Output bit in the Event Control register (EVCTRL.MCEO) enables the corresponding output event. Writing a '0' to this bit disables the corresponding output event.

#### 42.6.6 Sleep Mode Operation

The PDEC can be configured to operate in any sleep mode. To be able to run in standby, the RUNSTDBY bit in the Control A register (CTRLA.RUNSTDBY) must be written to '1'. The PDEC can wake up the device using interrupts from any sleep mode or perform actions through the Event System.

#### 42.6.7 Synchronization

Due to asynchronicity between the main clock domain and the peripheral clock domains, some registers need to be synchronized when written or read.

The following bits are synchronized when written:

- Software Reset bit in the Control A register (CTRLA.SWRST)
- Enable bit in the Control A register (CTRLA.ENABLE)

The following registers need synchronization when written:

- Control B Clear and Control B Set registers (CTRLBCLR and CTRLBSET)
- Status register (STATUS)
- Prescaler and Prescaler Buffer registers (PRESC and PRESCBUF)
- Compare Value x and Compare Value x Buffer registers (CCx and CCBUFx)
- Filter Value and Filter Buffer Value registers (FILTER and FILTERBUF)
- Counter Value register (COUNT)

Required write synchronization is denoted by the "Write-Synchronized" property in the register description.

The following registers are synchronized when read:

- Counter Value register (COUNT): the synchronization is done on demand through READSYNC software command (CTRLBSET.CMD)

Required read synchronization is denoted by the "Read-Synchronized" property in the register description.

## 42.7 Register Summary

Offset	Name	Bit Pos.	7	6	5	4	3	2	1	0	
0x00	CTRLA	7:0		RUNSTDBY			MODE[1:0]		ENABLE	SWRST	
		15:8	PEREN	SWAP			ALOCK	CONF[2:0]			
		23:16		PINVEN2	PINVEN1	PINVEN0		PINEN2	PINEN1	PINENO	
		31:24	MAXCMP[3:0]					ANGULAR[2:0]			
0x04	CTRLBCLR	7:0	CMD[2:0]					LUPD			
0x05	CTRLBSET	7:0	CMD[2:0]					LUPD			
0x06	EVCTRL	7:0	EVEI2	EVEI1	EVEI0	EVINV2	EVINV1	EVINV0	EVACT[1:0]		
		15:8			MCEO1	MCEO0	VLCEO	DIREO	ERREO	OVFEO	
0x08	INTENCLR	7:0			MC1	MC0	VLC	DIR	ERR	OVF	
0x09	INTENSET	7:0			MC1	MC0	VLC	DIR	ERR	OVF	
0x0A	INTFLAG	7:0			MC1	MC0	VLC	DIR	ERR	OVF	
0x0B	Reserved										
0x0C	STATUS	7:0	DIR	STOP	HERR	WINERR		MPERR	IDXERR	QERR	
		15:8			CCBUFV1	CCBUFV0			FILTERBUFV	PRESCBUFV	
0x0E	Reserved										
0x0F	DBGCTRL	7:0								DBGRUN	
0x10	SYNCBUSY	7:0	CC0	COUNT	FILTER	PRESC	STATUS	CTRLB	ENABLE	SWRST	
		15:8								CC1	
		23:16									
		31:24									
0x14	PRESC	7:0					PRESC[3:0]				
0x15	FILTER	7:0	FILTER[7:0]								
0x16	...										
0x17	Reserved										
0x18	PRESCBUF	7:0					PRESCBUF[3:0]				
0x19	FILTERBUF	7:0	FILTERBUF[7:0]								
0x1A	...										
0x1B	Reserved										
0x1C	COUNT	7:0	COUNT[7:0]								
		15:8	COUNT[15:8]								
		23:16									
		31:24									
0x20	CC0	7:0	CC[7:0]								
		15:8	CC[15:8]								
		23:16									
		31:24									
0x24	CC1	7:0	CC[7:0]								
		15:8	CC[15:8]								
		23:16									
		31:24									
0x28	...										
0x2F	Reserved										
0x30	CCBUF0	7:0	CCBUF[7:0]								
		15:8	CCBUF[15:8]								
		23:16									
		31:24									
0x34	CCBUF1	7:0	CCBUF[7:0]								
		15:8	CCBUF[15:8]								
		23:16									
		31:24									

## 42.7.1 Control A

**Name:** CTRLA  
**Offset:** 0x00  
**Reset:** 0x00000000  
**Property:** PAC Write-Protection, Enable-Protected

Bit	31	30	29	28	27	26	25	24
	MAXCMP[3:0]					ANGULAR[2:0]		
Access	RW	RW	RW	RW		RW	RW	RW
Reset	0	0	0	0		0	0	0
Bit	23	22	21	20	19	18	17	16
		PINVEN2	PINVEN1	PINVEN0		PINEN2	PINEN1	PINENO
Access		RW	RW	RW		RW	RW	RW
Reset		0	0	0		0	0	0
Bit	15	14	13	12	11	10	9	8
	PEREN	SWAP			ALOCK	CONF[2:0]		
Access	RW	RW			RW	RW	RW	RW
Reset	0	0			0	0	0	0
Bit	7	6	5	4	3	2	1	0
		RUNSTDBY			MODE[1:0]		ENABLE	SWRST
Access		RW			RW	RW	RW	W
Reset		0			0	0	0	0

### Bits 31:28 – MAXCMP[3:0] Maximum Consecutive Missing Pulses

These bits define the threshold for the maximum consecutive missing pulses in AUTOC configuration of the QDEC mode. Outside of AUTOC configuration of QDEC mode, these bits have no effect. These bits are not synchronized.

### Bits 26:24 – ANGULAR[2:0] Angular Counter Length

In QDEC mode, these bits define the size of the Angular counter within COUNT. Angular counter size is equal to CTRLA.ANGULAR+9. The remaining MSB of the COUNTER register are used for counting revolutions.

For example, CTRLA.ANGULAR=0 defines the 9 LSB of COUNT as Angular counter and the residual 7 MSB of COUNT as Revolution counter. CTRLA.ANGULAR=7 will define a 16-bit Angular counter and no Revolution counter.

Outside of QDEC mode, these bits have no effect. These bits are not synchronized.

**Table 42-1.** Angular and Revolution Counters in COUNTER Register

ANGULAR[2:0]	Angular counter	Revolution counter
0x0	COUNTER[0:8]	COUNTER[9:15]
0x1	COUNTER[0:9]	COUNTER[10:15]
0x2	COUNTER[0:10]	COUNTER[11:15]
0x3	COUNTER[0:11]	COUNTER[12:15]
0x4	COUNTER[0:12]	COUNTER[13:15]
0x5	COUNTER[0:13]	COUNTER[14:15]
0x6	COUNTER[0:14]	COUNTER[15]
0x7	COUNTER[0:15]	no revolution counter



### Bits 20, 21, 22 – PINVENx I/O Pin x Invert Enable

When this bit is written to '1', the corresponding input pin active level is inverted. This bit has no effect if the PINENx bit is zero.

In COUNTER mode only PINVEN[0] is significant.

This bit is not synchronized.

Value	Description
0	Pin active level is not inverted.
1	Pin active level is inverted.

### Bits 16, 17, 18 – PINENx PDEC Input From Pin x Enable

This bit enables the I/O pin x as signal input.

In COUNTER mode, only PINVEN[0] is significant.

This bit is not synchronized.

Value	Description
0	Event line is the signal input.
1	I/O pin is the signal input.

### Bit 15 – PEREN Period Enable

This bit is used to enable the CC0 register as counter period.

This bit is not synchronized.

Value	Description
0	Period register function is disabled.
1	CC0 is acting as counter period register.

### Bit 14 – SWAP PDEC Phase A and B Swap

This bit is used to swap input source of signal 0 and 1.

In COUNTER mode this bit has no effect.

This bit is not synchronized.

Value	Description
0	The input sources of signal 0 and 1 are not swapped.
1	The input sources of signal 0 and 1 are swapped.

### Bit 11 – ALOCK Auto Lock

When this bit is set, the Lock Update bit in Control B register (CTRLB.LUPD) is set by hardware when an UPDATE condition is detected.

This bit is not synchronized.

Value	Description
0	Auto Lock is disabled.
1	Auto Lock is enabled.

### Bits 10:8 – CONF[2:0] PDEC Configuration

These bits define the PDEC configuration.

Outside of QDEC mode, these bits have no effect.

These bits are not synchronized.

Value	Name	Description
0	X4	Quadrature decoder direction
1	X4S	Secure Quadrature decoder direction
2	X2	Decoder direction
3	X2S	Secure decoder direction
4	AUTO	Auto correction mode

### Bit 6 – RUNSTDBY Run in Standby

This bit is used to keep the PDEC running in standby mode.

This bit is not synchronized.

Value	Description
0	The PDEC is halted in standby.

Value	Description
1	The PDEC continues to run in standby.

### Bits 3:2 – MODE[1:0] Operation Mode

These bits select one of the QDEC, HALL, COUNTER modes. These bits are not synchronized.

Value	Name	Description
0x0	QDEC	QDEC operating mode
0x1	HALL	HALL operating mode
0x2	COUNTER	COUNTER operating mode

### Bit 1 – ENABLE Enable

Due to synchronization, there is delay between writing CTRLA.ENABLE until the peripheral is enabled/disabled. The value written to CTRLA.ENABLE will read back immediately, and the Enable Synchronization Busy bit in the Synchronization Busy register (SYNCBUSY.ENABLE) will be set. SYNCBUSY.ENABLE will be cleared when the operation is complete.

Value	Description
0	The peripheral is disabled.
1	The peripheral is enabled.

### Bit 0 – SWRST Software Reset

Writing a '0' to this bit has no effect.

Writing a '1' to this bit resets all registers in the PDEC (except DBGCTRL) to their initial state, and the PDEC will be disabled.

Writing a '1' to CTRLA.SWRST will always take precedence; all other writes in the same write-operation will be discarded.

Due to synchronization, there is a delay from writing CTRLA.SWRST until the Reset is complete. CTRLA.SWRST and SYNCBUSY.SWRST will be cleared when the Reset is complete.

#### Notes:

1. When the CTRLA.SWRST is written, the user must poll the SYNCBUSY.SWRST bit to know when the reset operation is complete.
2. During a SWRST, access to registers/bits without the SWRST are disallowed until the SYNCBUSY.SWRST is cleared by hardware.

Value	Description
0	There is no Reset operation ongoing.
1	A Reset operation is ongoing.

## 42.7.2 Control B Clear

**Name:** CTRLBCLR  
**Offset:** 0x04  
**Reset:** 0x00  
**Property:** PAC Write-Protection, Read-Synchronized, Write-Synchronized

This register allows the user to change this register without doing a read-modify-write operation. Changes in this register will also be reflected in the Control B Set (CTRLBSET) register.

**Note:** This register is read-synchronized and write-synchronized: SYNCBUSY.CTRLB must be checked to ensure the CTRLBCLR register synchronization is complete.

Bit	7	6	5	4	3	2	1	0
	CMD[2:0]						LUPD	
Access	RW	RW	RW				RW	
Reset	0	0	0				0	

### Bits 7:5 – CMD[2:0] Command

These bits can be used for software control of the PDEC. When a command has been executed, the CMD bit group will read back zero. The commands are executed on the next prescaled GCLK\_PDEC clock cycle.

Writing a zero to this bit group has no effect.

Writing a valid value to these bits will clear the corresponding pending command.

Writing a '0' to these bits has no effect.

Writing a '1' to an individual bit will clear the corresponding bit.

Value	Name	Description
0	NONE	No action
1	RETRIGGER	Force a counter restart or re-trigger
2	UPDATE	Force update of double buffered registers
3	READSYNC	Force a read synchronization of COUNT
4	START	Start QDEC/HALL
5	STOP	Stop QDEC/HALL

### Bit 1 – LUPD Lock Update

This bit controls the update operation of the PDEC buffered registers.

When CTRLB.LUPD is set, no any update of the registers with value of its buffered register is performed on hardware UPDATE condition. Locking the update ensures that all buffer registers are valid before an hardware update is performed. After all the buffer registers are loaded correctly, the buffered registers can be unlocked.

Writing a '0' to this bit has no effect.

Writing a '1' to this will disable the lock update.

Value	Description
0	The PRESCBUF, FILTERBUF and CCBUFx buffer registers value are copied into CCx and PER registers on hardware update condition.
1	The PRESCBUF, FILTERBUF and CCBUFx buffer registers value are not copied into CCx and PER registers on hardware update condition.

### 42.7.3 Control B Set

**Name:** CTRLBSET  
**Offset:** 0x05  
**Reset:** 0x00  
**Property:** PAC Write-Protection, Read-Synchronized, Write-Synchronized

This register allows the user to change this register without doing a read-modify-write operation. Changes in this register will also be reflected in the Control B Clear (CTRLBCLR) register.

**Note:** This register is read- and write-synchronized: SYNCBUSY.CTRLB must be checked to ensure the CTRLBSET register synchronization is complete.

Bit	7	6	5	4	3	2	1	0
	CMD[2:0]						LUPD	
Access	RW	RW	RW				RW	
Reset	0	0	0				0	

#### Bits 7:5 – CMD[2:0] Command

These bits can be used for software control of the PDEC. When a command has been executed, the CMD bit group will read back zero. The commands are executed on the next prescaled GCLK\_PDEC clock cycle.

Writing a zero to this bit group has no effect.

Writing a valid value to these bits will set the associated command.

Value	Name	Description
0	NONE	No action
1	RETRIGGER	Force a counter restart or retrigger
2	UPDATE	Force update of double buffered registers
3	READSYNC	Force a read synchronization of COUNT
4	START	Start QDEC/HALL
5	STOP	Stop QDEC/HALL

#### Bit 1 – LUPD Lock Update

This bit controls the update operation of the PDEC buffered registers.

When CTRLB.LUPD is set, no any update of the registers with value of its buffered register is performed on hardware UPDATE condition. Locking the update ensures that all buffer registers are valid before an hardware update is performed. After all the buffer registers are loaded correctly, the buffered registers can be unlocked.

Writing a '1' to this will enable the Lock Update.

Value	Description
0	The PRESCBUF, FILTERBUF and CCBUFx buffer registers value are copied into CCx and PER registers on hardware update condition.
1	The PRESCBUF, FILTERBUF and CCBUFx buffer registers value are not copied into CCx and PER registers on hardware update condition.

## 42.7.4 Event Control

**Name:** EVCTRL  
**Offset:** 0x06  
**Reset:** 0x0000  
**Property:** Enable-Protected, PAC Write-Protection

Bit	15	14	13	12	11	10	9	8
			MCEO1	MCEO0	VLCEO	DIREO	ERREO	OVFEO
Access			RW	RW	RW	RW	RW	RW
Reset			0	0	0	0	0	0
Bit	7	6	5	4	3	2	1	0
	EVEI2	EVEI1	EVEI0	EVINV2	EVINV1	EVINV0	EVACT[1:0]	
Access	RW	RW	RW	RW	RW	RW	RW	RW
Reset	0	0	0	0	0	0	0	0

### Bits 12, 13 – MCEOx Match Channel x Event Output Enable

These bits control whether event match on channel x is enabled or not and generated for every match.

Value	Description
0	Match event on channel x is disabled and will not be generated.
1	Match event on channel x is enabled and will be generated for every compare.

### Bit 11 – VLCEO Velocity Output Event Enable

This bit is used to enable the velocity event. When enabled, an event level will be generated for each change on the qualified PDEC phases.

This bit has no effect when COUNTER operation mode is selected.

Value	Description
0	VLC output event is disabled and will not be generated.
1	VLC output is enabled and will be generated for every valid velocity condition.

### Bit 10 – DIREO Direction Output Event Enable

This bit is used to enable the Direction event. When enabled, an event level output is generated to report the rotation direction.

Value	Description
0	DIR output event is disabled and will not be generated.
1	DIR output is enabled and changes the level when the rotation direction changes.

### Bit 9 – ERREO Error Output Event Enable

This bit enables the output of the Error event (ERR).

Value	Description
0	ERR Event output is disabled.
1	ERR Event output is enabled.

### Bit 8 – OVFEO Overflow/Underflow Output Event Enable

This bit is used to enable the Overflow/Underflow event. When enabled, an event will be generated when the Counter overflows/underflows.

Value	Description
0	Overflow/Underflow event is disabled and will not be generated.
1	Overflow/Underflow event is enabled and will be generated for every counter overflow/underflow.

### Bits 5, 6, 7 – EVEIx Event x Input Enable

This bit is used to enable asynchronous input event x to the counter.

Value	Description
0	Incoming event x is disabled.
1	Incoming event x is enabled.

**Bits 2, 3, 4 – EVINVx** Inverted Event x Input Enable

This bit inverts the asynchronous input event x to the counter.

Value	Description
0	Input event source x is not inverted.
1	Input event source x is inverted.

**Bits 1:0 – EFACT[1:0]** Event Action

These bits have an effect only when COUNTER operation mode is selected, and ignored in all other operation modes.

These bits define the event action the counter will perform on an event.

Value	Name	Description
0	OFF	Event action disabled
1–3	Reserved	-

## 42.7.5 Interrupt Enable Clear

**Name:** INTENCLR  
**Offset:** 0x08  
**Reset:** 0x00  
**Property:** PAC Write-Protection

This register allows the user to change this register without doing a read-modify-write operation. Changes in this register will also be reflected in the Interrupt Enable Set (INTENSET) register.

Bit	7	6	5	4	3	2	1	0
			MC1	MC0	VLC	DIR	ERR	OVF
Access			RW	RW	RW	RW	RW	RW
Reset			0	0	0	0	0	0

### Bits 4, 5 – MC Channel x Compare Match Disable

Writing a '0' to MCx has no effect.

Writing a '1' to MCx will clear the corresponding Match Channel x Interrupt Disable/Enable bit, which disables the Match Channel x interrupt.

Value	Description
0	The Match Channel x interrupt is disabled.
1	The Match Channel x interrupt is enabled.

### Bit 3 – VLC Velocity Interrupt Disable

Writing a '0' to this bit has no effect.

Writing a '1' to this bit will clear the Velocity Interrupt Disable/Enable bit, which disables the Velocity interrupt.

This bit has no effect when COUNTER operation mode is selected.

Value	Description
0	The Velocity interrupt is disabled.
1	The Velocity interrupt is enabled.

### Bit 2 – DIR Direction Interrupt Disable

Writing a '0' to this bit has no effect.

Writing a '1' to this bit will clear the Direction Change Interrupt Disable/Enable bit, which disables the Direction Change interrupt.

This bit has no effect when COUNTER operation mode is selected.

Value	Description
0	The Direction Change interrupt is disabled.
1	The Direction Change interrupt is enabled.

### Bit 1 – ERR Error Interrupt Disable

Writing a '0' to this bit has no effect.

Writing a '1' to this bit will clear the Error Interrupt Disable/Enable bit, which disables the Error interrupt.

Value	Description
0	The Error interrupt is disabled.
1	The Error interrupt is enabled.

### Bit 0 – OVF Overflow/Underflow Interrupt Disable

Writing a '0' to this bit has no effect.

Writing a '1' to this bit will clear the Overflow Interrupt Disable/Enable bit, which disables the Overflow interrupt.

Value	Description
0	The Overflow interrupt is disabled.

Value	Description
1	The Overflow interrupt is enabled.



## 42.7.6 Interrupt Enable Set

**Name:** INTENSET  
**Offset:** 0x09  
**Reset:** 0x00  
**Property:** PAC Write-Protection

This register allows the user to change this register without doing a read-modify-write operation. Changes in this register will also be reflected in the Interrupt Enable Clear (INTENCLR) register.

Bit	7	6	5	4	3	2	1	0
			MC1	MC0	VLC	DIR	ERR	OVF
Access			RW	RW	RW	RW	RW	RW
Reset			0	0	0	0	0	0

### Bits 4, 5 – MC Channel x Compare Match Enable

Writing a '0' to MCx has no effect.

Writing a '1' to MCx will set the corresponding Match Channel x Interrupt Disable/Enable bit, which enables the Match Channel x interrupt.

Value	Description
0	The Match Channel x interrupt is disabled.
1	The Match Channel x interrupt is enabled.

### Bit 3 – VLC Velocity Interrupt Enable

Writing a '0' to this bit has no effect.

Writing a '1' to this bit will set the Velocity Interrupt Disable/Enable bit, which enables the Velocity interrupt.

This bit has no effect when COUNTER operation mode is selected.

Value	Description
0	The Velocity interrupt is disabled.
1	The Velocity interrupt is enabled.

### Bit 2 – DIR Direction Interrupt Enable

Writing a '0' to this bit has no effect.

Writing a '1' to this bit will set the Direction Change Interrupt Disable/Enable bit, which enables the Direction Change interrupt.

This bit has no effect when COUNTER operation mode is selected.

Value	Description
0	The Direction Change interrupt is disabled.
1	The Direction Change interrupt is enabled.

### Bit 1 – ERR Error Interrupt Enable

Writing a '0' to this bit has no effect.

Writing a '1' to this bit will set the Error Interrupt Disable/Enable bit, which enables the Error interrupt.

Value	Description
0	The Error interrupt is disabled.
1	The Error interrupt is enabled.

### Bit 0 – OVF Overflow/Underflow Interrupt Enable

Writing a '0' to this bit has no effect.

Writing a '1' to this bit will set the Overflow Interrupt Disable/Enable bit, which enable the Overflow interrupt.

Value	Description
0	The Overflow interrupt is disabled.

Value	Description
1	The Overflow interrupt is enabled.

## 42.7.7 Interrupt Flag Status and Clear

**Name:** INTFLAG  
**Offset:** 0x0A  
**Reset:** 0x00  
**Property:** -

Bit	7	6	5	4	3	2	1	0
			MC1	MC0	VLC	DIR	ERR	OVF
Access			RW	RW	RW	RW	RW	RW
Reset			0	0	0	0	0	0

### Bits 4, 5 – MC Channel x Compare Match

This flag is set on the next CLK\_PDEC\_CNT cycle after a match with the compare condition, and will generate an interrupt request if the corresponding Match Channel x Interrupt Enable bit in the Interrupt Enable Set register (INTENSET.MCx) is '1'.

Writing a '0' to one of these bits has no effect.

Writing a '1' to one of these bits will clear the corresponding Match Channel x interrupt flag.

### Bit 3 – VLC Velocity

This flag is set if a velocity transition occurs, and will generate an interrupt request if the Velocity Interrupt Enable bit in Interrupt Enable Set register (INTENSET.VLC) is '1'.

Writing a '0' to this bit has no effect.

Writing a '1' to this bit clears the Velocity transition interrupt flag.

This flag is never set when COUNTER operation mode is selected.

### Bit 2 – DIR Direction Change

This flag is set if a direction change occurs, and will generate an interrupt request if the Direction Change Interrupt Enable bit in Interrupt Enable Set register (INTENSET.DIR) is '1'.

Writing a '0' to this bit has no effect.

Writing a '1' to this bit clears the Velocity transition interrupt flag.

This flag is never set when COUNTER operation mode is selected.

### Bit 1 – ERR Error

This flag is set when an error condition is detected, and will generate an interrupt request if the Error Interrupt Enable bit in the Interrupt Enable Set register (INTENSET.ERR) is '1'.

The error source can be identified by reading the Status (STATUS) register.

**Note:** An error detection (INTFLAG.ERR=1) updates the STATUS Error flags (HERR, WINERR, MPERR, IDXERR, QERR) with a variable delay. Poll the STATUS error flags until one of these bits is set.

Writing a '0' to this bit has no effect.

Writing a '1' to this bit clears the Error interrupt flag.

### Bit 0 – OVF Overflow/Underflow

This flag is set on the next CLK\_TC\_CNT cycle after an overflow condition occurs, and will generate an interrupt request if the Overflow Interrupt Enable bit in the Interrupt Enable Set register (INTENSET.OVF) is '1'.

Writing a '0' to this bit has no effect.

Writing a '1' to this bit clears the Overflow interrupt flag.

## 42.7.8 Status

**Name:** STATUS  
**Offset:** 0x0C  
**Reset:** 0x0040  
**Property:** Read-Synchronized, Write-Synchronized

**Note:** This register is read- and write-synchronized: SYNCBUSY.STATUS must be checked to ensure the STATUS register synchronization is complete.

Bit	15	14	13	12	11	10	9	8
			CCBUFV1	CCBUFV0			FILTERBUFV	PRESCBUFV
Access			R	R			R	R
Reset			0	0			0	0
Bit	7	6	5	4	3	2	1	0
	DIR	STOP	HERR	WINERR		MPERR	IDXERR	QERR
Access	R	R	RW	RW		RW	RW	RW
Reset	0	1	0	0		0	0	0

### Bits 12, 13 – CCBUFV Compare Channel x Buffer Valid

The bit is set when a new value is written to the corresponding CCBUF register.  
The bit is cleared by writing a '1' to the corresponding location or automatically cleared on an UPDATE condition.

### Bit 9 – FILTERBUFV Filter Buffer Valid

This bit is set when a new value is written to the PRESCALERBUF register.  
The bit is cleared by writing a '1' to the corresponding location or automatically cleared on an UPDATE condition.  
This bit is always read '0' when COUNTER operation mode is selected.

### Bit 8 – PRESCBUFV Prescaler Buffer Valid

This bit is set when a new value is written to the PRESC register.  
The bit is cleared by writing a '1' to the corresponding location or automatically cleared on an UPDATE condition.

### Bit 7 – DIR Direction Status Flag

This bit reflects the HALL/QDEC direction.  
in COUNTER mode, this bit is always read '0'.  
**Note:** STATUS.DIR bit status is not relevant if a direction change occurs (INTFLAG.DIR=1).

Value	Description
0	Clockwise direction.
1	Counter-clockwise direction.

### Bit 6 – STOP Stop

This bit reflects the HALL/QDEC decoding status.  
In COUNTER mode, this bit is always read '0'.

Value	Description
0	PDEC/HALL decoding is running.
1	PDEC/HALL decoding is stopped.

### Bit 5 – HERR Hall Error Flag

This flag is set when an invalid HALL code is detected.  
The flag is cleared by writing a '1' to this bit location.

Outside of HALL mode, this bits is always read '0'.

**Bit 4 – WINERR** Window Error Flag

This flag is set when the counter is outside the window monitor.

The flag is cleared by writing a '1' to this bit location.

Outside of HALL mode, this bits is always read '0'.

**Notes:**

1. Disable the WINERR (INTCLR.WINERR = 1) at first error detection, then re-enable it once the error root cause at the application level is solved.
2. Ignore the Windows Error (WINERR) flag after a START command execution, or when leaving standby.

**Bit 2 – MPERR** Missing Pulse Error flag

This flag is set when a missing pulse error condition is detected.

The flag is cleared by writing a '1' to this bit location.

Outside of QDEC mode, this bits is always read '0'.

**Bit 1 – IDXERR** Index Error Flag

This flag is set when an index error condition is detected.

The flag is cleared by writing a '1' to this bit location.

Outside of QDEC mode, this bits is always read '0'.

**Bit 0 – QERR** Quadrature Error Flag

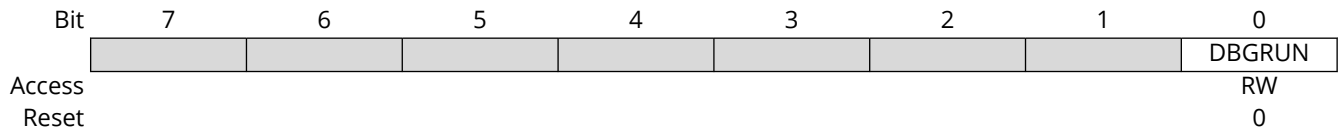
This flag is set when an invalid QDEC transition is detected.

The flag is cleared by writing a '1' to this bit location.

Outside of QDEC mode, this bits is always read '0'.

### 42.7.9 Debug Control

**Name:** DBGCTRL  
**Offset:** 0x0F  
**Reset:** 0x00  
**Property:** PAC Write-Protection



#### Bit 0 - DBGRUN Debug Run Mode

This bit is not affected by software reset and should not be changed by software while the PDEC module is enabled.

Value	Description
0	The PDEC module is halted when the device is halted in debug mode.
1	The PDEC module continues normal operation when the device is halted in debug mode.

## 42.7.10 Synchronization Status

**Name:** SYNCBUSY  
**Offset:** 0x10  
**Reset:** 0x00000000  
**Property:** Read-Only

Bit	31	30	29	28	27	26	25	24
Access								
Reset								
Bit	23	22	21	20	19	18	17	16
Access								
Reset								
Bit	15	14	13	12	11	10	9	8
Access								CC1
Reset								R 0
Bit	7	6	5	4	3	2	1	0
Access	CC0	COUNT	FILTER	PRESC	STATUS	CTRLB	ENABLE	SWRST
Reset	R 0	R 0	R 0	R 0	R 0	R 0	R 0	R 0

### Bits 7, 8 – CC Compare Channel x Synchronization Busy

This bit is cleared when the synchronization of Compare Channel x (CCx) register between the clock domains is complete.

This bit is set when the synchronization of Compare Channel x (CCx) register between clock domains is started.

### Bit 6 – COUNT Count Synchronization Busy

This bit is cleared when the synchronization of Count register between the clock domains is complete.

This bit is set when the synchronization of Count register between clock domains is started.

### Bit 5 – FILTER Filter Synchronization Busy

This bit is cleared when the synchronization of Filter register between the clock domains is complete.

This bit is set when the synchronization of Filter register between clock domains is started.

This bit is always read '0' when COUNTER operation mode is selected.

### Bit 4 – PRESC Prescaler Synchronization Busy

This bit is cleared when the synchronization of Prescaler register between the clock domains is complete.

This bit is set when the synchronization of Prescaler register between clock domains is started.

### Bit 3 – STATUS Status Synchronization Busy

This bit is cleared when the synchronization of Status register between the clock domains is complete.

This bit is set when the synchronization of Status register between clock domains is started.

**Bit 2 – CTRLB** Control B Synchronization Busy

This bit is cleared when the synchronization of Control B register between the clock domains is complete.

This bit is set when the synchronization of Control B register between clock domains is started.

**Bit 1 – ENABLE** Enable Synchronization Busy

This bit is cleared when the synchronization of Enable register bit between the clock domains is complete.

This bit is set when the synchronization of Enable register bit between clock domains is started.

**Bit 0 – SWRST** Software Reset Synchronization Busy

This bit is cleared when the synchronization of Software Reset register bit between the clock domains is complete.

This bit is set when the synchronization of Software Reset register bit between clock domains is started.



### 42.7.11 Prescaler Value

**Name:** PRESC  
**Offset:** 0x14  
**Reset:** 0x00  
**Property:** Write-Synchronized

**Note:** This register is write-synchronized: SYNCBUSY.PRESC must be checked to ensure the PRESC register synchronization is complete.

Bit	7	6	5	4	3	2	1	0
					PRESC[3:0]			
Access					RW	RW	RW	RW
Reset					0	0	0	0

#### Bits 3:0 – PRESC[3:0] Prescaler Value

These bits select the GCLK prescaler factor.

Value	Name	Description
0	DIV1	No division
1	DIV2	Divide by 2
2	DIV4	Divide by 4
3	DIV8	Divide by 8
4	DIV16	Divide by 16
5	DIV32	Divide by 32
6	DIV64	Divide by 64
7	DIV128	Divide by 128
8	DIV256	Divide by 256
9	DIV512	Divide by 512
10	DIV1024	Divide by 1024

### 42.7.12 Filter Value

**Name:** FILTER  
**Offset:** 0x15  
**Reset:** 0x00  
**Property:** Write-Synchronized

**Note:** This register is write-synchronized: SYNCBUSY.FILTER must be checked to ensure the FILTER register synchronization is complete.

Bit	7	6	5	4	3	2	1	0
	FILTER[7:0]							
Access	RW	RW	RW	RW	RW	RW	RW	RW
Reset	0	0	0	0	0	0	0	0

#### Bits 7:0 – FILTER[7:0] Filter Value

These bits select the PDEC inputs filter length.

These bits have no effect when COUNTER operation mode is selected.

### 42.7.13 Prescaler Buffer Value

**Name:** PRESCBUF  
**Offset:** 0x18  
**Reset:** 0x00  
**Property:** Write-Synchronized

**Note:** This register is write-synchronized: SYNCBUSY.PRESCBUF must be checked to ensure the PRESCBUF register synchronization is complete.

Bit	7	6	5	4	3	2	1	0
					PRESCBUF[3:0]			
Access					RW	RW	RW	RW
Reset					0	0	0	0

#### Bits 3:0 – PRESCBUF[3:0] Prescaler Buffer Value

These bits hold the value of the prescaler buffer register. The value is copied in the corresponding PRESC register on UPDATE condition.

Value	Name	Description
0	DIV1	No division
1	DIV2	Divide by 2
2	DIV4	Divide by 4
3	DIV8	Divide by 8
4	DIV16	Divide by 16
5	DIV32	Divide by 32
6	DIV64	Divide by 64
7	DIV128	Divide by 128
8	DIV256	Divide by 256
9	DIV512	Divide by 512
10	DIV1024	Divide by 1024

#### 42.7.14 Filter Buffer Value

**Name:** FILTERBUF  
**Offset:** 0x19  
**Reset:** 0x00  
**Property:** Write-Synchronized

**Note:** This register is write-synchronized: SYNCBUSY.FILTERBUF must be checked to ensure the FILTERBUF register synchronization is complete.

Bit	7	6	5	4	3	2	1	0
	FILTERBUF[7:0]							
Access	RW	RW	RW	RW	RW	RW	RW	RW
Reset	0	0	0	0	0	0	0	0

##### Bits 7:0 – FILTERBUF[7:0] Filter Buffer Value

These bits hold the value of the filter buffer register. The value is copied in the corresponding FILTER register on UPDATE condition.

These bits have no effect when COUNTER operation mode is selected.

### 42.7.15 Counter Value

**Name:** COUNT  
**Offset:** 0x1C  
**Reset:** 0x00000000  
**Property:** PAC Write-Protection, Read-Synchronized, Write-Synchronized

**Note:** This register is write-synchronized: SYNCBUSY.COUNT must be checked to ensure the COUNT register synchronization is complete.

Bit	31	30	29	28	27	26	25	24
Access								
Reset								
Bit	23	22	21	20	19	18	17	16
Access								
Reset								
Bit	15	14	13	12	11	10	9	8
	COUNT[15:8]							
Access	RW	RW	RW	RW	RW	RW	RW	RW
Reset	0	0	0	0	0	0	0	0
Bit	7	6	5	4	3	2	1	0
	COUNT[7:0]							
Access	RW	RW	RW	RW	RW	RW	RW	RW
Reset	0	0	0	0	0	0	0	0

#### Bits 15:0 – COUNT[15:0] Counter Value

These bits contain the counter value. To read the most updated counter value, the READSYNC software command must be applied first (CTRLBSET.CMD = READSYNC).

## 42.7.16 Channel x Compare Value

**Name:** CCx  
**Offset:** 0x20 + x\*0x04 [x=0..1]  
**Reset:** 0x00000000  
**Property:** Read-Synchronized, Write-Synchronized

**Note:** This register is write-synchronized: SYNCBUSY.CCx must be checked to ensure the CCx register synchronization is complete.

Bit	31	30	29	28	27	26	25	24
Access								
Reset								
Bit	23	22	21	20	19	18	17	16
Access								
Reset								
Bit	15	14	13	12	11	10	9	8
	CC[15:8]							
Access	RW	RW	RW	RW	RW	RW	RW	RW
Reset	0	0	0	0	0	0	0	0
Bit	7	6	5	4	3	2	1	0
	CC[7:0]							
Access	RW	RW	RW	RW	RW	RW	RW	RW
Reset	0	0	0	0	0	0	0	0

**Bits 15:0 – CC[15:0]** Channel Compare Value  
 These bits hold value of the channel x compare register.

### 42.7.17 Channel x Compare Buffer Value

**Name:** CCBUFx  
**Offset:** 0x30 + x\*0x04 [x=0..1]  
**Reset:** 0x00000000  
**Property:** Write-Synchronized

**Note:** This register is write-synchronized: SYNCBUSY.CCx must be checked to ensure the CCBUFx register synchronization is complete.

Bit	31	30	29	28	27	26	25	24
Access								
Reset								
Bit	23	22	21	20	19	18	17	16
Access								
Reset								
Bit	15	14	13	12	11	10	9	8
Access	CCBUF[15:8]							
Reset	RW	RW	RW	RW	RW	RW	RW	RW
Reset	0	0	0	0	0	0	0	0
Bit	7	6	5	4	3	2	1	0
Access	CCBUF[7:0]							
Reset	RW	RW	RW	RW	RW	RW	RW	RW
Reset	0	0	0	0	0	0	0	0

#### Bits 15:0 – CCBUF[15:0] Channel Compare Buffer Value

These bits hold the value of the channel x compare buffer register. The register is used as buffer for the associated compare register (CCx). Accessing this register using the CPU will affect the corresponding CCBVx status bit (STATUS.CCBUFVx).

## 43. Configurable Custom Logic (CCL)

### 43.1 Overview

The Configurable Custom Logic (CCL) is a programmable logic peripheral which can be connected to the device pins, to events, or to other internal peripherals. This allows the user to eliminate logic gates for simple glue logic functions on the PCB.

Each LookUp Table (LUT) consists of three inputs, a truth table, an optional synchronizer/filter, and an optional edge detector. Each LUT can generate an output as a user programmable logic expression with three inputs. Inputs can be individually masked.

The output can be combinatorially generated from the inputs, and can be filtered to remove spikes. Optional sequential logic can be used. The inputs of the sequential module are individually controlled by two independent, adjacent LUT (LUT0/LUT1) outputs, enabling complex waveform generation.

### 43.2 Features

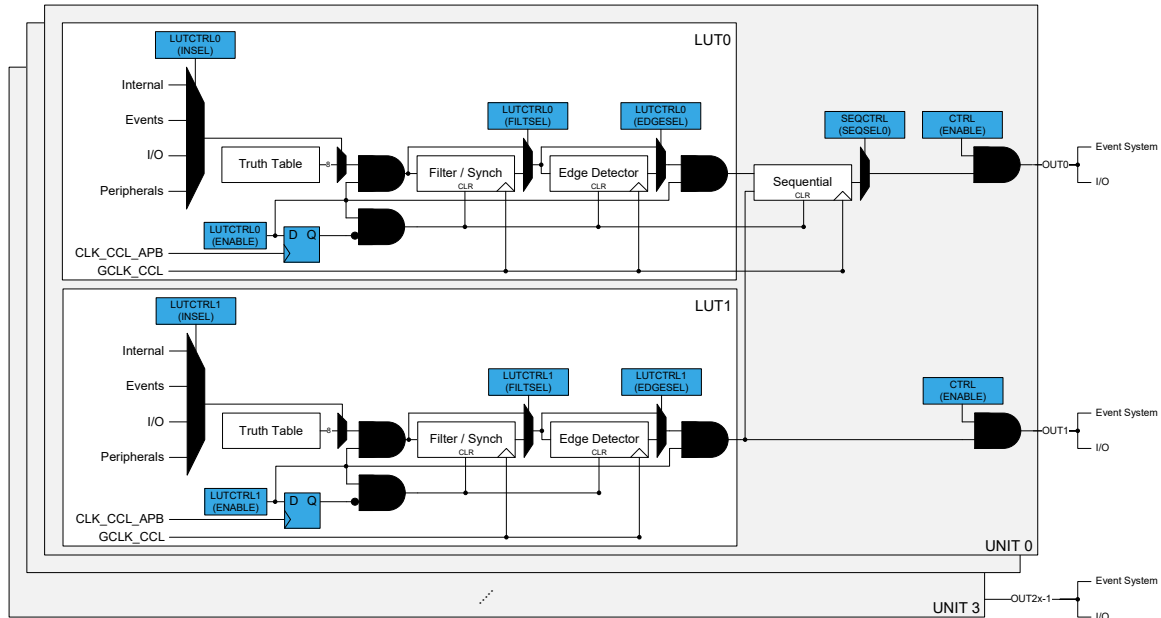
The following are key features of the CCL module:

- Glue logic for general purpose PCB design
- Up to 4 programmable LookUp Tables (LUTs)
- Combinatorial logic functions:  
AND, NAND, OR, NOR, XOR, XNOR, NOT
- Sequential logic functions:  
Gated D Flip-Flop, JK Flip-Flop, gated D Latch, RS Latch
- Flexible LUT inputs selection:
  - I/Os
  - Events
  - Internal peripherals
  - Subsequent LUT output
- Output can be connected to the I/O pins or the Event System
- Optional synchronizer, filter, or edge detector available on each LUT output



## 43.3 Block Diagram

Figure 43-1. Configurable Custom Logic



## 43.4 Signal Description

Pin Name	Type	Description
OUT[3:0]	Digital output	Output from lookup table
IN[11:0]	Digital input	Input to lookup table

For additional information on the pin mapping for this peripheral, refer to “I/O Multiplexing and Considerations”. One signal can be mapped on several pins.

## 43.5 Peripheral Dependencies

<b>Peripheral Name</b>	CCL – Configurable Custom Logic
<b>Base Address</b>	0x4200_3800 (Peripheral Bus C)
<b>MCLK APB Clock (1)</b>	CLK_CCL_APB, Disabled, APBCMASK.CCL
<b>GCLK Peripheral Channel Index:Clock Name (2)</b>	33 : GCLK_CCL
<b>PAC Peripheral Identifier (PAC.WRCTRL)</b>	78
<b>EVSYS Users (EVSYS.USERm) (3)</b>	63..66 : LUTx Input, x=0..3 (CCL_LUTIN 0..3) (A)
<b>EVSYS Generators (EVSYS.CHANNELn)</b>	116-119 : LUTx Output, x=0..3, (CCL_LUTOUT)
<b>Notes:</b>	
1.	Clock Name, Default State, Mask Field.
2.	See GCLK.PCHCTRLm Register, where m = Index.
3.	(A,S,R): A = Asynchronous path, S = Synchronous path, R = Resynchronized path.

### 43.5.1 I/O Lines

The CCL can take inputs and generate output through I/O pins. For this to function properly, the I/O pins must be configured to be used by a Look Up Table (LUT).

### 43.5.2 Power Management

This peripheral can continue to operate in any Sleep mode where its source clock is running. Events connected to the event system can trigger other operations in the system without exiting Sleep modes.

### 43.5.3 Clocks

The CCL bus clock (CLK\_CCL\_APB) can be enabled and disabled in the Main Clock module, MCLK (see [MCLK - Main Clock](#)), and the default state of CLK\_CCL\_APB can be found in [Peripheral Clock Masking](#).

A generic clock (GCLK\_CCL) is optionally required to clock the CCL. This clock must be configured and enabled in the Generic Clock Controller (GCLK) before using input events, filter, edge detection or sequential logic. GCLK\_CCL is required when input events, a filter, an edge detector, or a sequential sub-module is enabled. Refer to [GCLK - Generic Clock Controller](#) for details.

This generic clock is asynchronous to the user interface clock (CLK\_CCL\_APB).

### 43.5.4 Events

The CCL can use events from other peripherals and generate events that can be used by other peripherals. For this feature to function, the events have to be configured properly. Refer to the [EVSYS](#) chapter for more information about the event users and event generators.

### 43.5.5 Debug Operation

When the CPU is halted in Debug mode the CCL continues normal operation. However, the CCL cannot be halted when the CPU is halted in Debug mode. If the CCL is configured in a way that requires it to be periodically serviced by the CPU, improper operation or data loss may result during debugging.

### 43.5.6 Register Access Protection

All registers with write access can be write-protected optionally by the Peripheral Access Controller (PAC). Refer to [PAC - Peripheral Access Controller](#) for details.

Optional write protection by the Peripheral Access Controller (PAC) is denoted by the "PAC Write Protection" property in each individual register description.

PAC write protection does not apply to accesses through an external debugger.

## 43.6 Functional Description

### 43.6.1 Principle of Operation

Configurable Custom Logic (CCL) is a programmable logic block that can use the device port pins, internal peripherals, and the internal Event System as both input and output channels. The CCL can serve as glue logic between the device and external devices. The CCL can eliminate the need for external logic component and can also help the designer overcome challenging real-time constraints by combining core independent peripherals in clever ways to handle the most time critical parts of the application independent of the CPU.

### 43.6.2 Operation

#### 43.6.2.1 Initialization

The following bits are enable-protected, meaning that they can only be written when both the CCL and the corresponding even LUT are disabled (CTRL.ENABLE=0 and LUTCTRLx.ENABLE=0):

- Sequential Selection bits in the Sequential Control x (SEQCTRLx.SEQSEL) register

The following registers are enable-protected, meaning that they can only be written when both the CCL and the corresponding even LUT are disabled (CTRL.ENABLE=0 and LUTCTRLx.ENABLE=0):

- LUT Control x (LUTCTRLx) register, except the ENABLE bit

Enable-protected bits in the LUTCTRLx registers can be written at the same time as LUTCTRLx.ENABLE is written to '1', but not at the same time as LUTCTRLx.ENABLE is written to '0'.

Enable-protection is denoted by the Enable-Protected property in the register description.

### 43.6.2.2 Enabling, Disabling, and Resetting

The CCL is enabled by writing a '1' to the Enable bit in the Control register (CTRL.ENABLE). The CCL is disabled by writing a '0' to CTRL.ENABLE.



**Important:** In the case where the sequential logic is used and the LUT is disabled once, write CTRL.ENABLE again after LUT is enabled (LUTCTRL0.ENABLE = 1 / LUTCTRL2.ENABLE = 1) back.

Each LUT is enabled by writing a '1' to the Enable bit in the LUT Control x register (LUTCTRLx.ENABLE). Each LUT is disabled by writing a '0' to LUTCTRLx.ENABLE.

The CCL is reset by writing a '1' to the Software Reset bit in the Control register (CTRL.SWRST). All registers in the CCL will be reset to their initial state, and the CCL will be disabled. Refer to 43.7.1. CTRL for details.

**Note:** When the Peripheral Access Controller (PAC) is enabled for the CCL module (WRCTRL.PERID) and a Software Reset (CTRL.SWRST) is executed, a PAC protection error will be generated. If the PAC interrupt is enabled, the interrupt flag for the CCL module (INTFLAGC.CCL) should be cleared.

### 43.6.2.3 Lookup Table Logic

The lookup table in each LUT unit can generate any logic expression OUT as a function of three inputs (IN[2:0]), as shown in the following figure. One or more inputs can be masked. The truth table for the expression is defined by TRUTH bits in LUT Control x register (LUTCTRLx.TRUTH).

Figure 43-2. Truth Table Output Value Selection

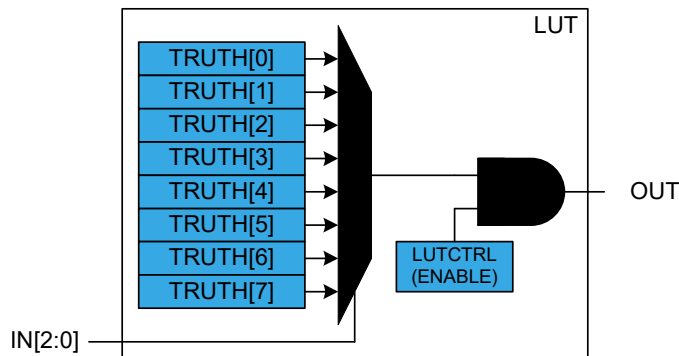


Table 43-1. Truth Table of LUT

IN[2]	IN[1]	IN[0]	OUT
0	0	0	TRUTH[0]
0	0	1	TRUTH[1]
0	1	0	TRUTH[2]
0	1	1	TRUTH[3]
1	0	0	TRUTH[4]
1	0	1	TRUTH[5]
1	1	0	TRUTH[6]

.....continued

IN[2]	IN[1]	IN[0]	OUT
1	1	1	TRUTH[7]

#### 43.6.2.4 Truth Table Inputs Selection

##### Input Overview

The inputs can be individually:

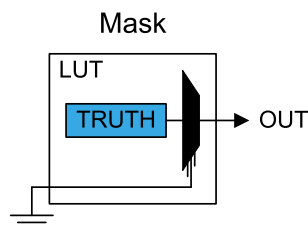
- Masked
- Driven by peripherals:
  - Analog comparator output (AC)
  - Timer/Counters waveform outputs (TC)
  - Serial Communication output transmit interface (SERCOM)
- Driven by internal events from Event System
- Driven by other CCL sub-modules

The Input Selection for each input 'y' of LUT x is configured by writing the Input 'y' Source Selection bit in the LUT x Control register (LUTCTRLx.INSELY).

##### Masked Inputs (MASK)

When a LUT input is masked (LUTCTRLx.INSELY = MASK), the corresponding TRUTH input (IN) is internally tied to zero, as shown in this figure:

Figure 43-3. Masked Input Selection



##### Internal Feedback Inputs (FEEDBACK)

When selected (LUTCTRLx.INSELY = FEEDBACK), the Sequential (SEQ) output is used as input for the corresponding LUT.

The output from an internal sequential sub-module can be used as input source for the LUT, see figure below for an example for LUT0 and LUT1. The sequential selection for each LUT follows the formula:

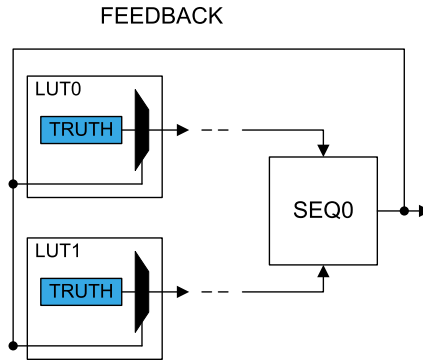
$$IN[2N][i] = SEQ[N]$$

$$IN[2N+1][i] = SEQ[N]$$

With  $N$  representing the sequencer number and  $i=0,1,2$  representing the LUT input index.

For additional information, refer to [43.6.2.7. Sequential Logic](#).

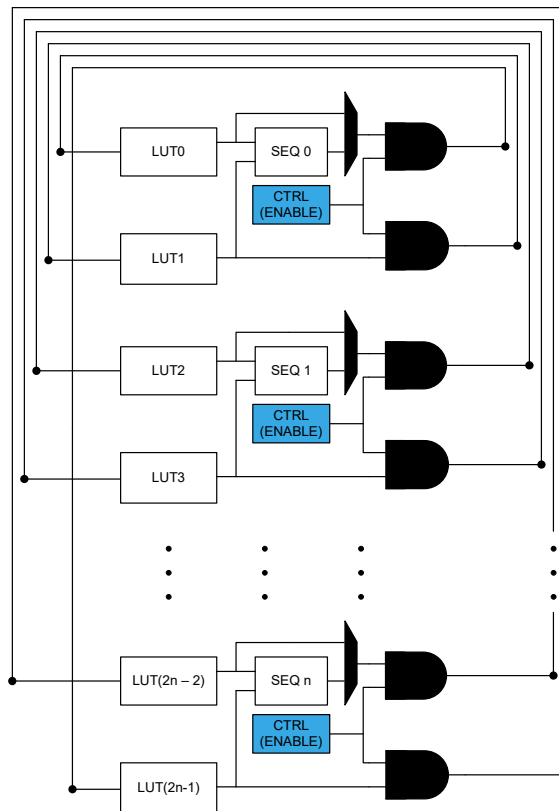
**Figure 43-4.** Feedback Input Selection



**Linked LUT (LINK)**

When selected (LUTCTRLx.INSELY=LINK), the subsequent LUT output is used as the LUT input (for example, LUT2 is the input for LUT1), as shown in the figure below:

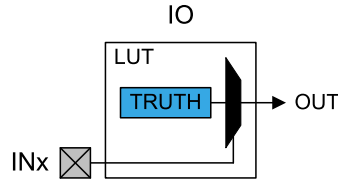
**Figure 43-5.** Linked LUT Input Selection



**I/O Pin Inputs (IO)**

When the I/O pin is selected as LUT input (LUTCTRLx.INSELY = IO), the corresponding LUT input will be connected to the pin, as shown in the figure below.

Figure 43-6. I/O Pin Input Selection



### Analog Comparator Inputs (AC)

The AC outputs can be used as input source for the LUT (LUTCTRLx.INSELY=AC).

The analog comparator outputs are distributed following the formula:

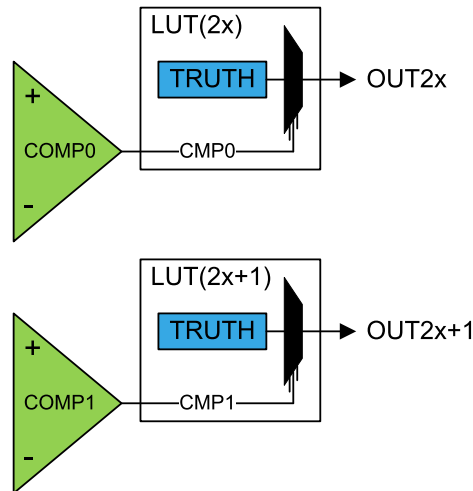
$$IN[N][i] = AC[N \% \text{ComparatorOutput\_Number}]$$

With  $N$  representing the LUT number and  $i=[0,1,2]$  representing the LUT input index.

Before selecting the comparator output, the AC must be configured first.

The output of comparator 0 is available on even LUTs ("LUT(2x)": LUT0, LUT2) and the comparator 1 output is available on odd LUTs ("LUT(2x+1)": LUT1, LUT3), as shown in the figure below.

Figure 43-7. AC Input Selection



### Timer/Counter Inputs (TC)

The TC waveform output WO[0] can be used as input source for the LUT (LUTCTRLx.INSELY = TC).

Only consecutive instances of the TC, that is, TC $x$  and the subsequent TC( $x+1$ ), are available as default and alternative TC selections (for example, TC0 and TC1 are sources for LUT0, TC1 and TC2 are sources for LUT1). See the figure below for an example for LUT0. More general, the Timer/Counter selection for each LUT follows the formula:

$$IN[N][i] = \text{DefaultTC}[N \% \text{TC\_Instance\_Number}]$$

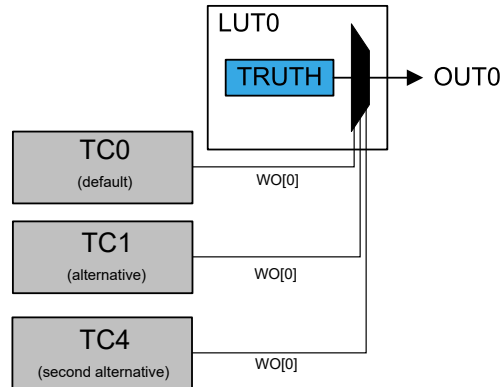
$$IN[N][i] = \text{AlternativeTC}[(N + 1) \% \text{TC\_Instance\_Number}]$$

Where  $N$  represents the LUT number and  $i$  represents the LUT input index ( $i=0,1,2$ ).

Note that for not implemented TC\_Instance\_Number, the corresponding input is tied to ground.

Before selecting the waveform outputs, the TC must be configured first.

**Figure 43-8.** TC Input Selection



### Timer/Counter for Control Application Inputs (TCC)

The TCC waveform outputs can be used as input source for the LUT. Only WO[2:0] outputs can be selected and routed to the respective LUT input (that is, IN0 is connected to WO0, IN1 to WO1, and IN2 to WO2), as shown in the figure below.

**Note:**

The TCC selection for each LUT follows the formula:

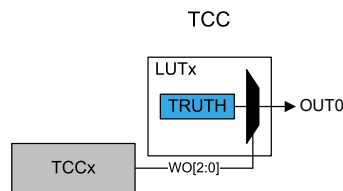
$$IN[N][i] = TCC[N \% TCC\_Instance\_Number].WO[i]$$

Where  $N$  represents the LUT number and  $i$  represents the LUT input index ( $i=0,1,2$ ).

Before selecting the waveform outputs, the TCC must be configured first.

**Note:** TCC2 only outputs 2 WO signals, so TCC2.WO[0] is connected to both LUT2.IN[0] and LUT2.IN[2], and TCC2.WO[1] is connected to LUT2.IN[1].

**Figure 43-9.** TCC Input Selection



### Serial Communication Output Transmit Inputs (SERCOM)

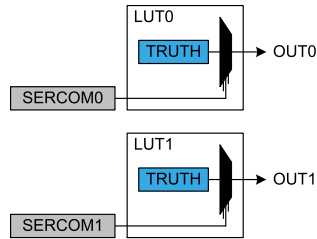
The serial engine transmitter output from Serial Communication Interface (SERCOM TX, TXd for USART, MOSI for SPI) can be used as input source for the LUT. The figure below shows an example for LUT0 and LUT1. The SERCOM selection for each LUT follows the formula:

$$IN[N][i] = SERCOM[N \% SERCOM\_Instance\_Number]$$

With  $N$  representing the LUT number and  $i=0,1,2$  representing the LUT input index.

Before selecting the SERCOM as input source, the SERCOM must be configured first: the SERCOM TX signal must be output on SERCOMn/pad[0], which serves as input pad to the CCL.

Figure 43-10. SERCOM Input Selection



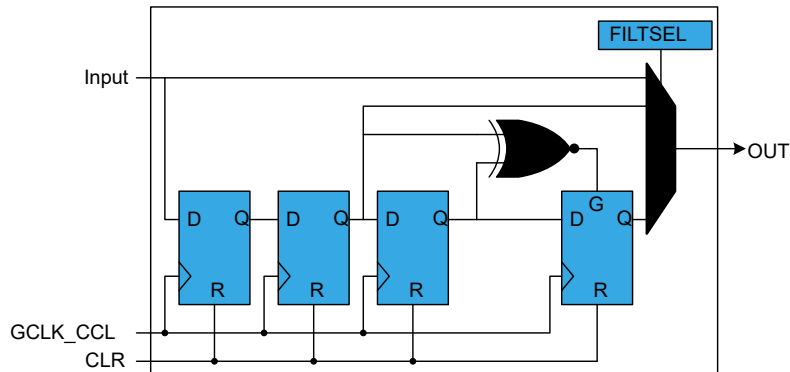
### 43.6.2.5 Filter

By default, the LUT output is a combinatorial function of the LUT inputs. This may cause some short glitches when the inputs change value. These glitches can be removed by clocking through filters, if demanded by application needs.

The Filter Selection bits in LUT Control register (LUTCTRLx.FILTSEL) define the synchronizer or digital filter options. When a filter is enabled, the OUT output will be delayed by two to five GCLK cycles. One APB clock after the corresponding LUT is disabled, all internal filter logic is cleared.

**Note:** Events used as LUT input will also be filtered, if the filter is enabled.

Figure 43-11. Filter



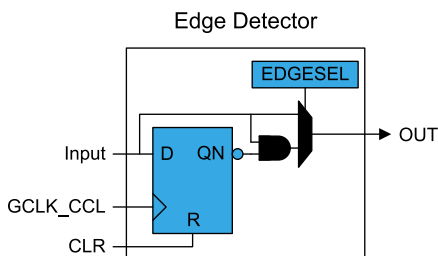
### 43.6.2.6 Edge Detector

The edge detector can be used to generate a pulse when detecting a rising edge on its input. To detect a falling edge, the TRUTH table should be inverted.

The edge detector is enabled by writing '1' to the Edge Selection bit in LUT Control register (LUTCTRLx.EDGESEL). In order to avoid unpredictable behavior, either the filter or synchronizer must be enabled.

Edge detection is disabled by writing a '0' to LUTCTRLx.EDGESEL. After disabling a LUT, the corresponding internal Edge Detector logic is cleared one APB clock cycle later.

Figure 43-12. Edge Detector





### 43.6.2.7 Sequential Logic

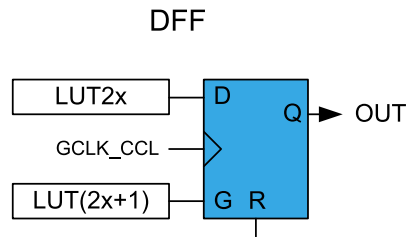
Each LUT pair can be connected to the internal sequential logic which can be configured to work as D flip flop, JK flip flop, gated D-latch or RS-latch by writing the Sequential Selection bits on the corresponding Sequential Control x register (SEQCTRLx.SEQSEL). Before using sequential logic, the GCLK\_CCL clock and optionally each LUT filter or edge detector must be enabled.

**Note:** While configuring the sequential logic, the even LUT must be disabled. When configured the even LUT must be enabled.

#### Gated D Flip-Flop (DFF)

When the DFF is selected, the D-input is driven by the even LUT output (LUT0 and LUT2), and the G-input is driven by the odd LUT output (LUT1 and LUT3), as shown in the following figure.

Figure 43-13. D Flip Flop



When the even LUT is disabled (LUTCTRL0.ENABLE=0 / LUTCTRL2.ENABLE=0), the flip-flop is asynchronously cleared. The reset command (R) is kept enabled for one APB clock cycle. In all other cases, the flip-flop output (OUT) is refreshed on rising edge of the GCLK\_CCL, as shown in the following table.

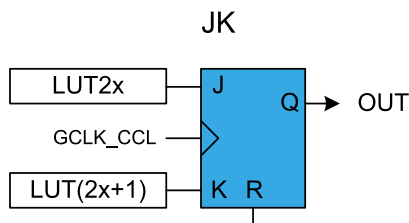
Table 43-2. DFF Characteristics

R	G	D	OUT
1	X	X	Clear
0	1	1	Set
		0	Clear
0	0	X	Hold state (no change)

#### JK Flip-Flop (JK)

When this configuration is selected, the J-input is driven by the even LUT output (LUT0 and LUT2), and the K-input is driven by the odd LUT output (LUT1 and LUT3), as shown in the following figure.

Figure 43-14. JK Flip Flop



When the even LUT is disabled (LUTCTRL0.ENABLE=0 / LUTCTRL2.ENABLE=0), the flip-flop is asynchronously cleared. The reset command (R) is kept enabled for one APB clock cycle. In all other cases, the flip-flop output (OUT) is refreshed on rising edge of the GCLK\_CCL, as shown in the following table.

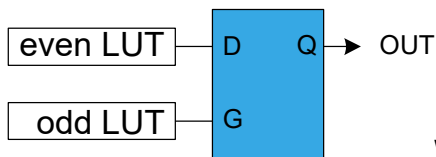
**Table 43-3. JK Characteristics**

R	J	K	OUT
1	X	X	Clear
0	0	0	Hold state (no change)
0	0	1	Clear
0	1	0	Set
0	1	1	Toggle

### Gated D-Latch (DLATCH)

When the DLATCH is selected, the D-input is driven by the even LUT output (LUT0 and LUT2), and the G-input is driven by the odd LUT output (LUT1 and LUT3), as shown in the following figure.

**Figure 43-15. D-Latch**



When the even LUT is disabled (LUTCTRL0.ENABLE=0 / LUTCTRL2.ENABLE=0), the latch output will be cleared. The G-input is forced enabled for one more APB clock cycle, and the D-input to zero. In all other cases, the latch output (OUT) is refreshed as shown in the following table.

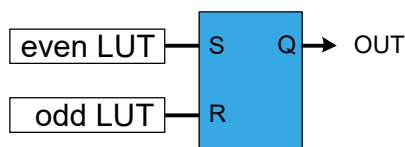
**Table 43-4. D-Latch Characteristics**

G	D	OUT
0	X	Hold state (no change)
1	0	Clear
1	1	Set

### RS Latch (RS)

When this configuration is selected, the S-input is driven by the even LUT output (LUT0 and LUT2), and the R-input is driven by the odd LUT output (LUT1 and LUT3), as shown in the following figure.

**Figure 43-16. RS-Latch**



When the even LUT is disabled LUTCTRL0.ENABLE=0 / LUTCTRL2.ENABLE=0), the latch output will be cleared. The R-input is forced enabled for one more APB clock cycle and S-input to zero. In all other cases, the latch output (OUT) is refreshed as shown in the following table.

**Table 43-5. RS-Latch Characteristics**

S	R	OUT
0	0	Hold state (no change)
0	1	Clear
1	0	Set
1	1	Forbidden state

### 43.6.3 Events

The CCL can generate the following output events:

- LUTOUT<sub>n</sub> with n=0-3: Lookup Table Output Value

Writing a '1' to the LUT Control Event Output Enable bit (LUTCTRL<sub>x</sub>.LUTEO) enables the corresponding output event. Writing a '0' to this bit disables the corresponding output event.

The CCL can take the following actions on an input event:

- INSEL<sub>x</sub>: The event is used as input for the TRUTH table. For additional information, refer to [43.5.4. Events](#).

Writing a '1' to the LUT Control Event Input Enable bit (LUTCTRL<sub>x</sub>.LUTEI) enables the corresponding action on input event. Writing a '0' to this bit disables the corresponding action on input event.

### 43.6.4 Sleep Mode Operation

When using the GCLK\_CCL internal clocking, writing the Run In Standby bit in the Control register (CTRL.RUNSTDBY) to '1' will allow GCLK\_CCL to be enabled in Standby Sleep mode.

If CTRL.RUNSTDBY=0, the GCLK\_CCL will be disabled in Standby Sleep mode. If the Filter, Edge Detector or Sequential logic are enabled, the LUT output will be forced to zero in STANDBY mode. In all other cases, the TRUTH table decoder will continue operation and the LUT output will be refreshed accordingly.

## 43.7 Register Summary

Offset	Name	Bit Pos.	7	6	5	4	3	2	1	0
0x00	<a href="#">CTRL</a>	7:0		RUNSTDBY					ENABLE	SWRST
0x01	Reserved									
0x03										
0x04	<a href="#">SEQCTRL0</a>	7:0						SEQSEL[3:0]		
0x05	<a href="#">SEQCTRL1</a>	7:0						SEQSEL[3:0]		
0x06	Reserved									
0x07										
0x08	<a href="#">LUTCTRL0</a>	7:0	EDGESEL		FILTSEL[1:0]				ENABLE	
		15:8	INSEL1[3:0]			INSEL0[3:0]				
		23:16	LUTEO	LUTEI	INVEI	INSEL2[3:0]				
		31:24	TRUTH[7:0]							
0x0C	<a href="#">LUTCTRL1</a>	7:0	EDGESEL		FILTSEL[1:0]				ENABLE	
		15:8	INSEL1[3:0]			INSEL0[3:0]				
		23:16	LUTEO	LUTEI	INVEI	INSEL2[3:0]				
		31:24	TRUTH[7:0]							
0x10	<a href="#">LUTCTRL2</a>	7:0	EDGESEL		FILTSEL[1:0]				ENABLE	
		15:8	INSEL1[3:0]			INSEL0[3:0]				
		23:16	LUTEO	LUTEI	INVEI	INSEL2[3:0]				
		31:24	TRUTH[7:0]							
0x14	<a href="#">LUTCTRL3</a>	7:0	EDGESEL		FILTSEL[1:0]				ENABLE	
		15:8	INSEL1[3:0]			INSEL0[3:0]				
		23:16	LUTEO	LUTEI	INVEI	INSEL2[3:0]				
		31:24	TRUTH[7:0]							

### 43.7.1 Control

**Name:** CTRL  
**Offset:** 0x00  
**Reset:** 0x00  
**Property:** PAC Write-Protection

**Note:** CTRL register (except the bits ENABLE & SWRST) is Enable Protected when CCL.CTRL.ENABLE = 1.

Bit	7	6	5	4	3	2	1	0
		RUNSTDBY					ENABLE	SWRST
Access		R/W					R/W	W
Reset		0					0	0

#### Bit 6 – RUNSTDBY Run in Standby

This bit indicates if the GCLK\_CCL clock must be kept running in standby mode. The setting is ignored for configurations where the generic clock is not required. For details refer to [43.6.4. Sleep Mode Operation](#).



**Important:** This bit must be written before enabling the CCL.

Value	Description
0	Generic clock is not required in standby sleep mode.
1	Generic clock is required in standby sleep mode.

#### Bit 1 – ENABLE Enable

**Note:** In the case where the sequential logic is used and the LUT is disabled once, write CTRL.ENABLE again after LUT is enabled (LUTCTRL0.ENABLE = 1 / LUTCTRL2.ENABLE = 1) back.

Value	Description
0	The peripheral is disabled.
1	The peripheral is enabled.

#### Bit 0 – SWRST Software Reset

Writing a '0' to this bit has no effect.  
 Writing a '1' to this bit resets all registers in the CCL to their initial state.

Value	Description
0	There is no reset operation ongoing.
1	The reset operation is ongoing.

### 43.7.2 Sequential Control x

**Name:** SEQCTRL  
**Offset:** 0x04 + n\*0x01 [n=0..1]  
**Reset:** 0x00  
**Property:** PAC Write-Protection, Enable-Protected

**Note:** SEQCTRLx register is Enable-protected when CTRL.ENABLE = 1 or LUTCTRLx.ENABLE = 1.

Bit	7	6	5	4	3	2	1	0
					SEQSEL[3:0]			
Access					R/W	R/W	R/W	R/W
Reset					0	0	0	0

#### Bits 3:0 – SEQSEL[3:0] Sequential Selection

These bits select the sequential configuration:  
Sequential Selection

Value	Name	Description
0x0	DISABLE	Sequential logic is disabled
0x1	DFF	D flip flop
0x2	JK	JK flip flop
0x3	LATCH	D latch
0x4	RS	RS latch
0x5 – 0xF		Reserved

### 43.7.3 LUT Control n

**Name:** LUTCTRLn  
**Offset:** 0x08 + n\*0x04 [n=0..3]  
**Reset:** 0x00000000  
**Property:** PAC Write-Protection, Enable-protected

**Note:** LUTCTRLn register is Enable Protected when CTRL.ENABLE = 1 or LUTCTRLx.ENABLE = 1.

Bit	31	30	29	28	27	26	25	24
	TRUTH[7:0]							
Access	R/W	R/W	R/W	R/W	R/W	R/W	R/W	R/W
Reset	0	0	0	0	0	0	0	0
Bit	23	22	21	20	19	18	17	16
		LUTE0	LUTE1	INVEI	INSEL2[3:0]			
Access		R/W	R/W	R/W	R/W	R/W	R/W	R/W
Reset		0	0	0	0	0	0	0
Bit	15	14	13	12	11	10	9	8
	INSEL1[3:0]				INSEL0[3:0]			
Access	R/W	R/W	R/W	R/W	R/W	R/W	R/W	R/W
Reset	0	0	0	0	0	0	0	0
Bit	7	6	5	4	3	2	1	0
	EDGESEL		FILTSEL[1:0]				ENABLE	
Access	R/W		R/W	R/W			R/W	
Reset	0		0	0			0	

#### Bits 31:24 – TRUTH[7:0] Truth Table

These bits define the value of truth logic as a function of inputs IN[2:0].

#### Bit 22 – LUTE0 LUT Event Output Enable

Value	Description
0	LUT event output is disabled.
1	LUT event output is enabled.

#### Bit 21 – LUTE1 LUT Event Input Enable

Value	Description
0	LUT incoming event is disabled.
1	LUT incoming event is enabled.

#### Bit 20 – INVEI Inverted Event Input Enable

Value	Description
0	Incoming event is not inverted.
1	Incoming event is inverted.

#### Bits 8:11, 12:15, 16:19 – INSELx LUT Input x Source Selection

These bits select the LUT input x source:

Value	Name	Description
0x0	MASK	Masked input
0x1	FEEDBACK	Feedback input source
0x2	LINK	Linked LUT input source
0x3	EVENT	Event input source
0x4	IO	I/O pin input source

Value	Name	Description
0x5	AC	AC input source: CMP[0] (LUT0) / CMP[1] (LUT1)/ CMP[2] (LUT2) / CMP[3] (LUT3)
0x6	TC	TC input source: TC0 (LUT0) / TC1 (LUT1)/ TC2 (LUT2) / TC3 (LUT3)
0x7	ALTTC	Alternative TC input source: TC1 (LUT0) / TC2 (LUT1) / TC3 (LUT2) / TC4 (LUT3)
0x8	TCC	TCC input source: TCC0 (LUT0) / TCC1 (LUT1) / TCC2 (LUT2) / TCC0 (LUT3)
0x9	SERCOM	SERCOM input source: SERCOM0 (LUT0) / SERCOM1 (LUT1)/ SERCOM2 (LUT2) / SERCOM3 (LUT3)
0xA - 0xF	Reserved	Reserved

#### Bit 7 - EDGESEL Edge Selection

Value	Description
0	Edge detector is disabled.
1	Edge detector is enabled.

#### Bits 5:4 - FILTSEL[1:0] Filter Selection

These bits select the LUT output filter options:

Filter Selection

Value	Name	Description
0x0	DISABLE	Filter disabled
0x1	SYNCH	Synchronizer enabled
0x2	FILTER	Filter enabled
0x3	-	Reserved

#### Bit 1 - ENABLE LUT Enable

Value	Description
0	The LUT is disabled.
1	The LUT is enabled.



## 44. Timer/Counter (TC)

### 44.1 Overview

There are up to eight TC peripheral instances. Each TC consists of a counter, a prescaler, compare/capture channels and control logic. The counter can be set to count events or clock pulses. The counter, together with the compare/capture channels, can be configured to timestamp input events or I/O pin edges, allowing for capturing of frequency and/or pulse width.

A TC can also perform waveform generation, such as frequency generation and pulse-width modulation.

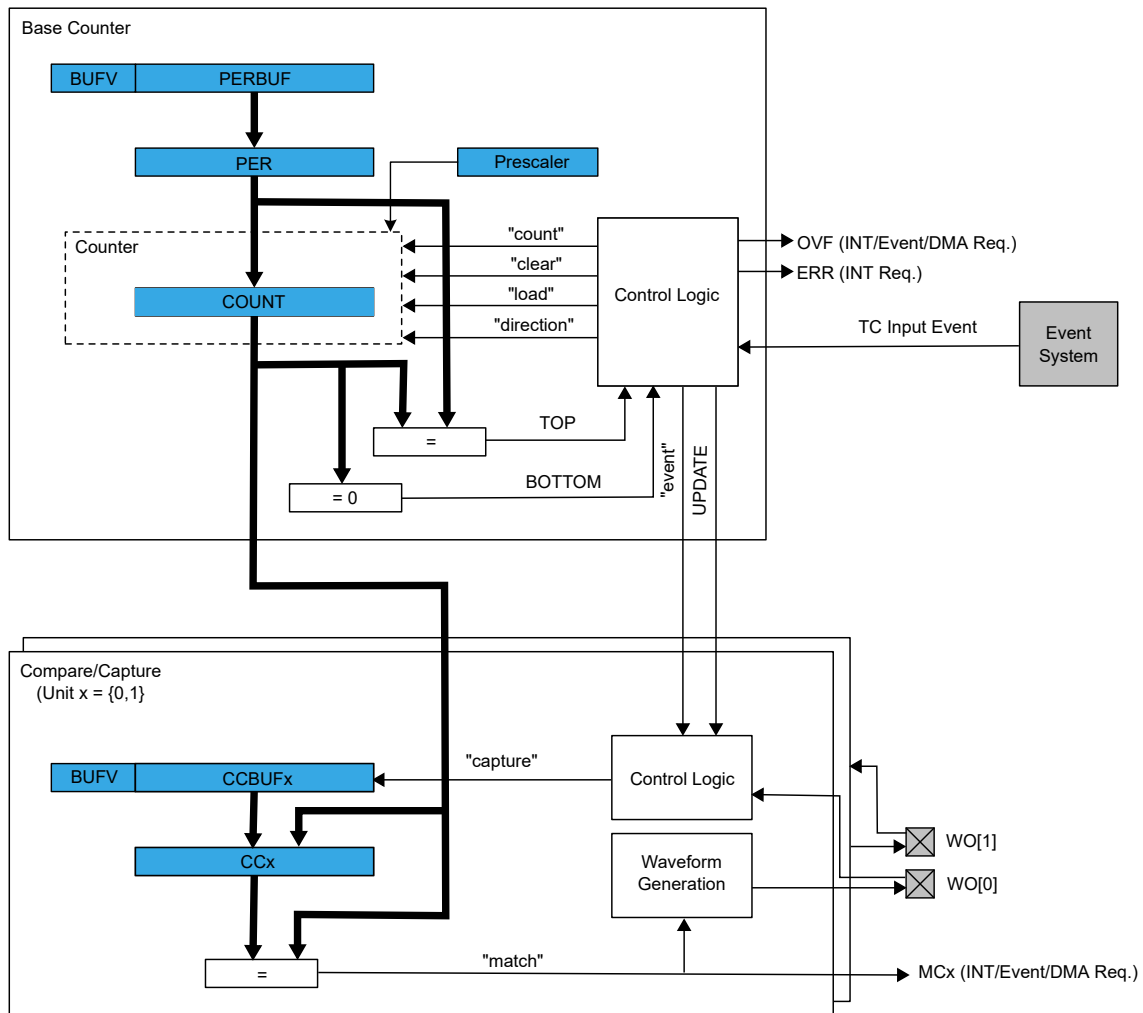
### 44.2 Features

The following are key features of the TC module:

- Selectable configuration
  - 8-bit, 16-bit or 32-bit TC operation with compare/capture channels
- 2 compare/capture channels (CC) with:
  - Double buffered timer period setting (in 8-bit mode only)
  - Double buffered compare channel
- Waveform generation
  - Frequency generation
  - Single-slope Pulse-Width Modulation (PWM)
- Input capture
  - Event or I/O pin edge capture
  - Frequency capture
  - Pulse-width capture
  - Time-stamp capture
  - Minimum and maximum capture
- One input event
- Interrupts/output events on:
  - Counter overflow/underflow
  - Compare match or capture
- Internal prescaler
- DMA support

## 44.3 Block Diagram

Figure 44-1. Timer/Counter Block Diagram



## 44.4 Signal Description

Table 44-1. Signal Description for TC.

Signal Name	Type	Description
WO[1:0]	Digital output	Waveform output
	Digital input	Capture input



I/Os for TC peripheral are grouped into I/O sets, listed in their 'IOSET' column in the pinout tables.

For these peripherals, it is mandatory to use I/Os that belong to the same I/O set. The timings are not guaranteed when I/Os from different I/O sets are mixed. Refer to the [Pinout and Packaging](#) chapter to get IOSET definitions.

## 44.5 Peripheral Dependencies

<b>Peripheral Name</b>	TC0 – Timer/Counter 0
<b>Base Address</b>	0x4000_3800 (Peripheral Bus A)
<b>NVIC IRQ Index:Source</b>	107 : ERR , MC0, MC1, OVF
<b>MCLK APB Clock (1)</b>	CLK_TC0_APB, Disabled, APBAMASK.TC0
<b>GCLK Peripheral Channel Index:Clock Name (2)</b>	9 : GCLK_TC0, GCLK_TC1
<b>PAC Peripheral Peripheral Identifier (PAC.WRCTRL)</b>	14
<b>DMA Trigger Index:Source (DMAC.CHCTRLAK,k=0,1,...31)</b>	44 : Overflow (OVF) 45,46 : Match/Compare (MC)
<b>EVSYS Users (EVSYS.USERm) (3)</b>	44 : TC0 Input (TC0 EVU) (A,S,R)
<b>EVSYS Generators (EVSYS.CHANNELn)</b>	73 : Overflow (TC0_OVF) 74,75 : Match/Compare x, x=0,1 (TC0_MCx)

<b>Peripheral Name</b>	TC1 – Timer/Counter 1
<b>Base Address</b>	0x4000_3C00 (Peripheral Bus A)
<b>NVIC IRQ Index:Source</b>	108 : ERR , MC0, MC1, OVF
<b>MCLK APB Clock (1)</b>	CLK_TC1_APB, Disabled, APBAMASK.TC1
<b>GCLK Peripheral Channel Index:Clock Name (2)</b>	9 : GCLK_TC0, GCLK_TC1
<b>PAC Peripheral Peripheral Identifier (PAC.WRCTRL)</b>	15
<b>DMA Trigger Index:Source (DMAC.CHCTRLAK,k=0,1,...31)</b>	47 : Overflow (OVF) 48,49 : Match/Compare (MC)
<b>EVSYS Users (EVSYS.USERm) (3)</b>	45 : TC1 Input (TC1 EVU) (A,S,R)
<b>EVSYS Generators (EVSYS.CHANNELn)</b>	76 : Overflow (TC1_OVF) 77,78 : Match/Compare x, x=0,1 (TC1_MCx)

<b>Peripheral Name</b>	TC2 – Timer/Counter 2
<b>Base Address</b>	0x4101_A000 (Peripheral Bus B)
<b>NVIC IRQ Index:Source</b>	109 : ERR , MC0, MC1, OVF
<b>MCLK APB Clock (1)</b>	CLK_TC2_APB, Disabled, APBBMASK.TC2
<b>GCLK Peripheral Channel Index:Clock Name (2)</b>	26 : GCLK_TC2, GCLK_TC3
<b>PAC Peripheral Peripheral Identifier (PAC.WRCTRL)</b>	45
<b>DMA Trigger Index:Source (DMAC.CHCTRLAK,k=0,1,...31)</b>	50 : Overflow (OVF) 51,52 : Match/Compare (MC)
<b>EVSYS Users (EVSYS.USERm) (3)</b>	46 : TC2 Input (TC2 EVU) (A,S,R)
<b>EVSYS Generators (EVSYS.CHANNELn)</b>	79 : Overflow (TC2_OVF) 80,81 : Match/Compare x, x=0,1 (TC2_MCx)

<b>Peripheral Name</b>	TC3 – Timer/Counter 3
<b>Base Address</b>	0x4101_C000 (Peripheral Bus B)
<b>NVIC IRQ Index:Source</b>	110 : ERR , MC0, MC1, OVF
<b>MCLK APB Clock (1)</b>	CLK_TC3_APB, Disabled, APBBMASK.TC3
<b>GCLK Peripheral Channel Index:Clock Name (2)</b>	26 : GCLK_TC2, GCLK_TC3
<b>PAC Peripheral Peripheral Identifier (PAC.WRCTRL)</b>	46
<b>DMA Trigger Index:Source (DMAC.CHCTRLAK,k=0,1,...31)</b>	53 : Overflow (OVF) 54,55 : Match/Compare (MC)
<b>EVSYS Users (EVSYS.USERm) (3)</b>	47 : TC3 Input (TC3 EVU) (A,S,R)

<b>EVSYS Generators (EVSYS.CHANNELn)</b>	82 : Overflow (TC3_OVF) 83,84 : Match/Compare x, x=0,1 (TC3_MCx)
--	--

<b>Peripheral Name</b>	TC4 – Timer/Counter 4
<b>Base Address</b>	0x4200_1400 (Peripheral Bus C)
<b>NVIC IRQ Index:Source</b>	111 : ERR , MC0, MC1, OVF
<b>MCLK APB Clock (1)</b>	CLK_TC4_APB, Disabled, APBCMASK.TC4
<b>GCLK Peripheral Channel Index:Clock Name (2)</b>	30 : GCLK_TC4, GCLK_TC5
<b>PAC Peripheral Peripheral Identifier (PAC.WRCTRL)</b>	69
<b>DMA Trigger Index:Source (DMAC.CHCTRLAK,k=0,1,...31)</b>	56 : Overflow (OVF) 57,58 : Match/Compare (MC)
<b>EVSYS Users (EVSYS.USERm) (3)</b>	48 : TC4 Input (TC4 EVU) (A,S,R)
<b>EVSYS Generators (EVSYS.CHANNELn)</b>	85 : Overflow (TC4_OVF) 86,87 : Match/Compare x, x=0,1 (TC4_MCx)

<b>Peripheral Name</b>	TC5 – Timer/Counter 5
<b>Base Address</b>	0x4200_1800 (Peripheral Bus C)
<b>NVIC IRQ Index:Source</b>	112 : ERR , MC0, MC1, OVF
<b>MCLK APB Clock (1)</b>	CLK_TC5_APB, Disabled, APBCMASK.TC5
<b>GCLK Peripheral Channel Index:Clock Name (2)</b>	30 : GCLK_TC4, GCLK_TC5
<b>PAC Peripheral Peripheral Identifier (PAC.WRCTRL)</b>	70
<b>DMA Trigger Index:Source (DMAC.CHCTRLAK,k=0,1,...31)</b>	59 : Overflow (OVF) 60,61 : Match/Compare (MC)
<b>EVSYS Users (EVSYS.USERm) (3)</b>	49 : TC5 Input (TC5 EVU) (A,S,R)
<b>EVSYS Generators (EVSYS.CHANNELn)</b>	88 : Overflow (TC5_OVF) 89,90 : Match/Compare x, x=0,1 (TC5_MCx)

<b>Peripheral Name</b>	TC6 – Timer/Counter 6
<b>Base Address</b>	0x4300_1400 (Peripheral Bus D)
<b>NVIC IRQ Index:Source</b>	113 : ERR , MC0, MC1, OVF
<b>MCLK APB Clock (1)</b>	CLK_TC6_APB, Disabled, APBDMASK.TC6
<b>GCLK Peripheral Channel Index:Clock Name (2)</b>	39 : GCLK_TC6, GCLK_TC7
<b>PAC Peripheral Peripheral Identifier (PAC.WRCTRL)</b>	101
<b>DMA Trigger Index:Source (DMAC.CHCTRLAK,k=0,1,...31)</b>	62 : Overflow (OVF) 63,64 : Match/Compare (MC)
<b>EVSYS Users (EVSYS.USERm) (3)</b>	50 : TC6 Input (TC6 EVU) (A,S,R)
<b>EVSYS Generators (EVSYS.CHANNELn)</b>	91 : Overflow (TC6_OVF) 92,93 : Match/Compare x, x=0,1 (TC6_MCx)

<b>Peripheral Name</b>	TC7 – Timer/Counter 7
<b>Base Address</b>	0x4300_1800 (Peripheral Bus D)
<b>NVIC IRQ Index:Source</b>	114 : ERR , MC0, MC1, OVF
<b>MCLK APB Clock (1)</b>	CLK_TC7_APB, Disabled, APBDMASK.TC7
<b>GCLK Peripheral Channel Index:Clock Name (2)</b>	39 : GCLK_TC6, GCLK_TC7
<b>PAC Peripheral Peripheral Identifier (PAC.WRCTRL)</b>	102
<b>DMA Trigger Index:Source (DMAC.CHCTRLAK,k=0,1,...31)</b>	65 : Overflow (OVF) 66,67 : Match/Compare (MC)
<b>EVSYS Users (EVSYS.USERm) (3)</b>	51 : TC7 Input (TC7 EVU) (A,S,R)
<b>EVSYS Generators (EVSYS.CHANNELn)</b>	94 : Overflow (TC7_OVF) 95,96 : Match/Compare x, x=0,1 (TC7_MCx)

**Notes:**

1. Clock Name, Default State, Mask Field.
2. See GCLK.PCHCTRLm Register, where m = Index.
3. (A,S,R): A = Asynchronous path, S = Synchronous path, R = Resynchronized path.

**44.5.1 Power Management**

This peripheral can continue to operate in any Sleep mode where its source clock is running. The interrupts can wake up the device from Sleep modes. Events connected to the event system can trigger other operations in the system without exiting Sleep modes.

**44.5.2 Clocks**

The TC bus clocks (CLK\_TCx\_APB) can be enabled and disabled in the Main Clock Module. The default state of CLK\_TCx\_APB can be found in the [Peripheral Clock Masking](#).

The generic clocks (GCLK\_TCx) are asynchronous to the user interface clock (CLK\_TCx\_APB). Due to this asynchronicity, accessing certain registers will require synchronization between the clock domains. Refer to [Synchronization](#) for further details.

**Note:** Two instances of the TC may share a peripheral clock channel. In this case, they cannot be set to different clock frequencies. Refer to the peripheral clock channel mapping of the [Generic Clock Controller](#) (GCLK.PCHCTRLm) to identify shared peripheral clocks.

**44.5.3 Debug Operation**

When the CPU is halted in Debug mode, this peripheral will halt normal operation. This peripheral can be forced to continue operation during debugging - refer to the Debug Control ([DBGCTRL](#)) register for details.

**44.5.4 Register Access Protection**

Registers with write access can be optionally write-protected by the [Peripheral Access Controller \(PAC\)](#), except for the following:

- Interrupt Flag Status and Clear register (INTFLAG)
- Status register (STATUS)
- Period and Period Buffer registers (PER, PERBUF)
- Compare/Capture Value registers and Compare/Capture Value Buffer registers (CCx, CCBUFx)

**Note:** Optional write protection is indicated by the "PAC Write Protection" property in the register description.

Write protection does not apply for accesses through an external debugger.

**44.6 Functional Description**

**44.6.1 Principle of Operation**

The following definitions are used throughout the documentation:

**Table 44-2.** Timer/Counter Definitions

Name	Description
TOP	The counter reaches TOP when it becomes equal to the highest value in the count sequence. The TOP value can be the same as Period (PER) or the Compare Channel 0 (CC0) register value depending on the waveform generator mode in <a href="#">44.6.2.6.1. Waveform Output Operations</a> .
ZERO	The counter is ZERO when it contains all zeroes
MAX	The counter reaches MAX when it contains all ones

.....continued	
Name	Description
UPDATE	The timer/counter signals an update when it reaches ZERO or TOP, depending on the direction settings.
Timer	The timer/counter clock control is handled by an internal source
Counter	The clock control is handled externally (e.g. counting external events)
CC	For compare operations, the CC are referred to as “compare channels” For capture operations, the CC are referred to as “capture channels.”

Each TC instance has up to two compare/capture channels (CC0 and CC1).

The counter in the TC can either count events from the Event System, or clock ticks of the GCLK\_TCx clock, which may be divided by the prescaler.

The counter value is passed to the CCx where it can be either compared to user-defined values or captured.

For optimized timing the CCx and CCBUFx registers share a common resource. When writing into CCBUFx, lock the access to the corresponding CCx register (SYNCBUSY.CCx = 1) till the CCBUFx register value is not loaded into the CCx register (BUFVx == 1). Each buffer register has a buffer valid (BUFV) flag that indicates when the buffer contains a new value.

The Counter register (COUNT) and the Compare and Capture registers with buffers (CCx and CCBUFx) can be configured as 8-, 16- or 32-bit registers, with according MAX values. Mode settings (CTRLA.MODE) determine the maximum range of the Counter register.

In 8-bit mode, a Period Value (PER) register and its Period Buffer Value (PERBUF) register are also available. The counter range and the operating frequency determine the maximum time resolution achievable with the TC peripheral.

The TC can be set to count up or down. Under normal operation, the counter value is continuously compared to the TOP or ZERO value to determine whether the counter has reached that value. On a comparison match the TC can request DMA transactions, or generate interrupts or events for the Event System.

In compare operation, the counter value is continuously compared to the values in the CCx registers. In case of a match the TC can request DMA transactions, or generate interrupts or events for the Event System. In waveform generator mode, these comparisons are used to set the waveform period or pulse width.

Capture operation can be enabled to perform input signal period and pulse width measurements, or to capture selectable edges from an IO pin or internal event from Event System.

## 44.6.2 Basic Operation

### 44.6.2.1 Initialization

The following registers are enable-protected, meaning that they can only be written when the TC is disabled (CTRLA.ENABLE = 0):

- The Control A register (CTRLA), except the Enable (ENABLE) and Software Reset (SWRST) bits
- The Drive Control register (DRVCTRL)
- The Wave register (WAVE)
- The Event Control register (EVCTRL)

Writing to Enable-Protected bits and setting the CTRLA.ENABLE bit can be performed in a single 32-bit access of the CTRLA register. Writing to Enable-Protected bits and clearing the CTRLA.ENABLE bit cannot be performed in a single 32-bit access.

Before enabling the TC, the peripheral must be configured using the following steps:

1. Enable the TC bus clock (CLK\_TCx\_APB).
2. Select 8-bit, 16-bit, or 32-bit counter mode through the TC Mode bit group in the Control A register (CTRLA.MODE). The default mode is 16-bit.
3. Select one wave generation operation in the Waveform Generation Operation bit group in the WAVE register (WAVE.WAVEGEN).
4. If desired, the GCLK\_TCx clock can be prescaled via the Prescaler bit group in the Control A register (CTRLA.PRESCALER).
  - If the prescaler is used, select a prescaler synchronization operation via the Prescaler and Counter Synchronization bit group in the Control A register (CTRLA.PRESYNC).
5. If desired, select one-shot operation by writing a '1' to the One-Shot bit in the Control B Set register (CTRLBSET.ONESHOT).
6. If desired, configure the counting direction 'down' (starting from the TOP value) by writing a '1' to the Counter Direction bit in the Control B register (CTRLBSET.DIR).
7. For capture operation, enable the individual channels to capture in the Capture Channel x Enable bit group in the Control A register (CTRLA.CAPTEN).
8. If desired, enable inversion of the waveform output or IO pin input signal for individual channels via the Invert Enable bit group in the Drive Control register (DRVCTRL.INVEN).

#### 44.6.2.2 Enabling, Disabling, and Resetting

The TC is enabled by writing a '1' to the Enable bit in the Control A register (CTRLA.ENABLE). The TC is disabled by writing a zero to CTRLA.ENABLE.

The TC is reset by writing a '1' to the Software Reset bit in the Control A register (CTRLA.SWRST). All registers in the TC, except DBGCTRL, will be reset to their initial state. Refer to the CTRLA register for details.

The TC should be disabled before the TC is reset in order to avoid undefined behavior.

#### 44.6.2.3 Prescaler Selection

The GCLK\_TCx is fed into the internal prescaler.

The prescaler consists of a counter that counts up to the selected prescaler value, whereupon the output of the prescaler toggles.

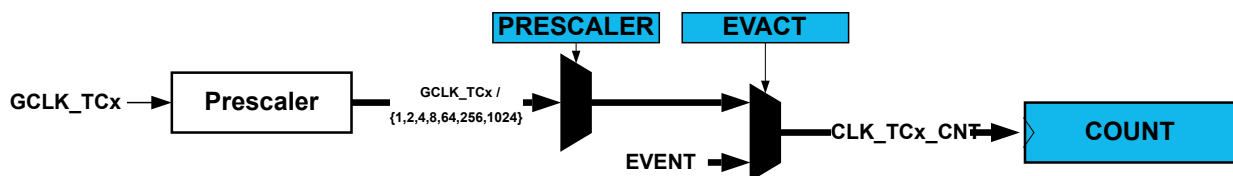
If the prescaler value is higher than one, the Counter Update condition can be optionally executed on the next GCLK\_TCx clock pulse or the next prescaled clock pulse. For further details, refer to Prescaler (CTRLA.PRESCALER) and Counter Synchronization (CTRLA.PRESYNC) description.

Prescaler outputs from 1 to 1/1024 are available. For a complete list of available prescaler outputs, see the register description for the Prescaler bit group in the Control A register (CTRLA.PRESCALER).

**Note:** When counting events, the prescaler is bypassed.

The joint stream of prescaler ticks and event action ticks is called CLK\_TCx\_CNT.

Figure 44-2. Prescaler



#### 44.6.2.4 Counter Mode

The counter mode is selected by the Mode bit group in the Control A register (CTRLA.MODE). By default, the counter is enabled in the 16-bit counter resolution. Three counter resolutions are available:

- COUNT8: The 8-bit TC has its own Period Value and Period Buffer Value registers (PER and PERBUF).
- COUNT16: 16-bit is the default counter mode. There is no dedicated period register in this mode.
- COUNT32: 32-bit mode is achieved by pairing two 16-bit TC peripherals. TC(2n) is paired with TC(2n+1).

When paired, the TC peripherals are configured using the registers of the even-numbered TC. The TC bus clocks (CLK\_TCx\_APB) for both Host and Client TCs need to be enabled.

The odd-numbered partner will act as a Client, and the Client bit in the Status register (STATUS.Client) will be set. The register values of a Client will not reflect the registers of the 32-bit counter. Writing to any of the Client registers will not affect the 32-bit counter. Normal access to the Client COUNT and CCx registers is not allowed.

#### 44.6.2.5 Counter Operations

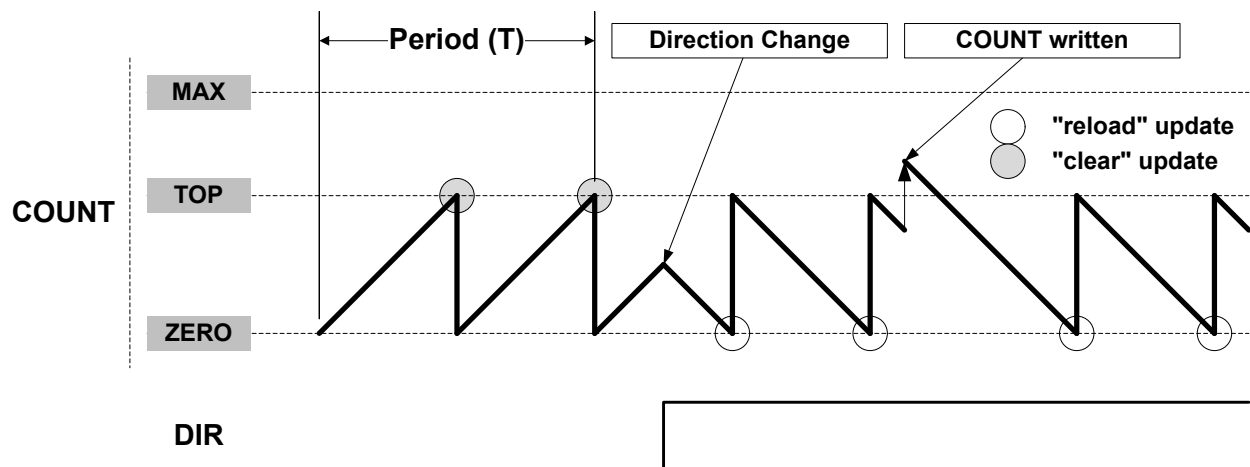
Depending on the mode of operation, the counter is cleared, reloaded, incremented, or decremented at each TC clock input (CLK\_TCx\_CNT). A counter clear or reload marks the end of the current counter cycle and the start of a new one.

The counting direction is set by the Direction bit in the Control B register (CTRLB.DIR). If this bit is zero the counter is counting up, and counting down if CTRLB.DIR=1. The counter will count up or down for each tick (clock or event) until it reaches TOP or ZERO. When it is counting up and TOP is reached, the counter will be set to zero at the next tick (overflow) and the Overflow Interrupt Flag in the Interrupt Flag Status and Clear register (INTFLAG.OVF) will be set. When it is counting down, the counter is reloaded with the TOP value when ZERO is reached (underflow), and INTFLAG.OVF is set.

INTFLAG.OVF can be used to trigger an interrupt, a DMA request, or an event. An overflow/underflow occurrence (i.e., a compare match with TOP/ZERO) will stop counting if the One-Shot bit in the Control B register is set (CTRLBSET.ONESHOT).

It is possible to change the counter value (by writing directly in the COUNT register) even when the counter is running. When starting the TC, the COUNT value will be either ZERO or TOP (depending on the counting direction set by CTRLBSET.DIR or CTRLBCLR.DIR), unless a different value has been written to it, or the TC has been stopped at a value other than ZERO. The write access has higher priority than count, clear, or reload. The direction of the counter can also be changed when the counter is running. See also the following figure.

Figure 44-3. Counter Operation





Due to asynchronous clock domains, the internal counter settings are written when the synchronization is complete. Normal operation must be used when using the counter as timer base for the capture channels.

#### 44.6.2.5.1 Stop Command and Event Action

A Stop command can be issued from software by using Command bits in the Control B Set register (CTRLBSET.CMD = 0x2, STOP). When a Stop is detected while the counter is running, the counter will not retain its current value. All waveforms are cleared and the Stop bit in the Status register is set (STATUS.STOP).

#### 44.6.2.5.2 Re-Trigger Command and Event Action

A re-trigger command can be issued from software by writing the Command bits in the Control B Set register (CTRLBSET.CMD = 0x1, RETRIGGER), or from event when a re-trigger event action is configured in the Event Control register (EVCTRL.EVACT = 0x1, RETRIGGER).

When the command is detected during counting operation, the counter will be reloaded or cleared, depending on the counting direction (CTRLBSET.DIR or CTRLBCLR.DIR). When the re-trigger command is detected while the counter is stopped, the counter will resume counting from the current value in the COUNT register.

**Note:** When a re-trigger event action is configured in the Event Action bits in the Event Control register (EVCTRL.EVACT=0x1, RETRIGGER), enabling the counter will not start the counter. The counter will start on the next incoming event and restart on corresponding following event.

#### 44.6.2.5.3 Count Event Action

The TC can count events. When an event is received, the counter increases or decreases the value, depending on direction settings (CTRLBSET.DIR or CTRLBCLR.DIR). The count event action can be selected by the Event Action bit group in the Event Control register (EVCTRL.EVACT=0x2, COUNT).

**Note:** If this operation mode is selected, PWM generation is not supported.

#### 44.6.2.5.4 Start Event Action

The TC can start counting operation on an event when previously stopped. In this configuration, the event has no effect if the counter is already counting. When the peripheral is enabled, the counter operation starts when the event is received or when a re-trigger software command is applied.

The Start TC on Event action can be selected by the Event Action bit group in the Event Control register (EVCTRL.EVACT=0x3, START).

#### 44.6.2.6 Compare Operations

By default, the Compare/Capture channel is configured for compare operations.

When using the TC and the Compare/Capture Value registers (CCx) for compare operations, the counter value is continuously compared to the values in the CCx registers. This can be used for timer or for waveform operation.

The Channel x Compare Buffer (CCBUFx) registers provide double buffer capability. The double buffering synchronizes the update of the CCx register with the buffer value at the UPDATE condition or a forced update command (CTRLBSET.CMD=UPDATE). For further details, refer to [44.6.2.7. Double Buffering](#). The synchronization prevents the occurrence of odd-length, non-symmetrical pulses and ensures glitch-free output.

#### 44.6.2.6.1 Waveform Output Operations

The compare channels can be used for waveform generation on output port pins. To make the waveform available on the connected pin, the following requirements must be fulfilled:

1. Choose a Waveform Generation mode in the Waveform Generation Operation bit in Waveform register (WAVE.WAVEGEN).
2. Optionally invert the waveform output WO[x] by writing the corresponding Output Waveform x Invert Enable bit in the Driver Control register (DRVCTRL.INVENx).

- Configure the pins with the I/O Pin Controller. Refer to [PORT - I/O Pin Controller](#) for details.  
**Note:** Event must not be used when the compare channel is set in waveform output operating mode.

The counter value is continuously compared with each CCx value. On a comparison match, the Match or Capture Channel x bit in the Interrupt Flag Status and Clear register (INTFLAG.MCx) will be set on the next zero-to-one transition of CLK\_TCx\_CNT (see Normal Frequency Operation). An interrupt/and or event can be generated on comparison match if enabled. The same condition generates a DMA request.

There are four waveform configurations for the Waveform Generation Operation bit group in the Waveform register (WAVE.WAVEGEN). This will influence how the waveform is generated and impose restrictions on the top value. The configurations are:

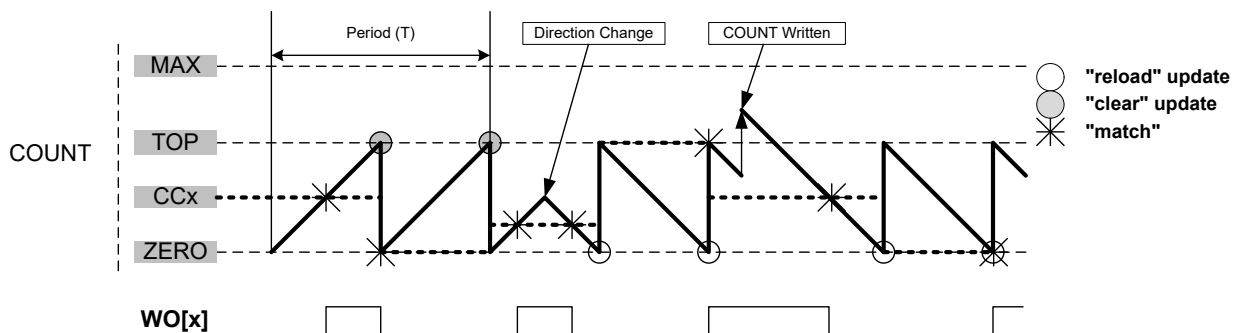
- Normal frequency (NFRQ)
- Match frequency (MFRQ)
- Normal pulse-width modulation (NPWM)
- Match pulse-width modulation (MPWM)

When using NPWM or NFRQ configuration, the TOP will be determined by the counter resolution. In 8-bit Counter mode, the Period register (PER) is used as TOP, and the TOP can be changed by writing to the PER register. In 16- and 32-bit Counter mode, TOP is fixed to the maximum (MAX) value of the counter.

#### Normal Frequency Generation (NFRQ)

For Normal Frequency Generation, the period time (T) is controlled by the period register (PER) for 8-bit Counter mode and MAX for 16- and 32-bit mode. The waveform generation output (WO[x]) is toggled on each compare match between COUNT and CCx, and the corresponding Match or Capture Channel x Interrupt Flag (INTFLAG.MCx) will be set.

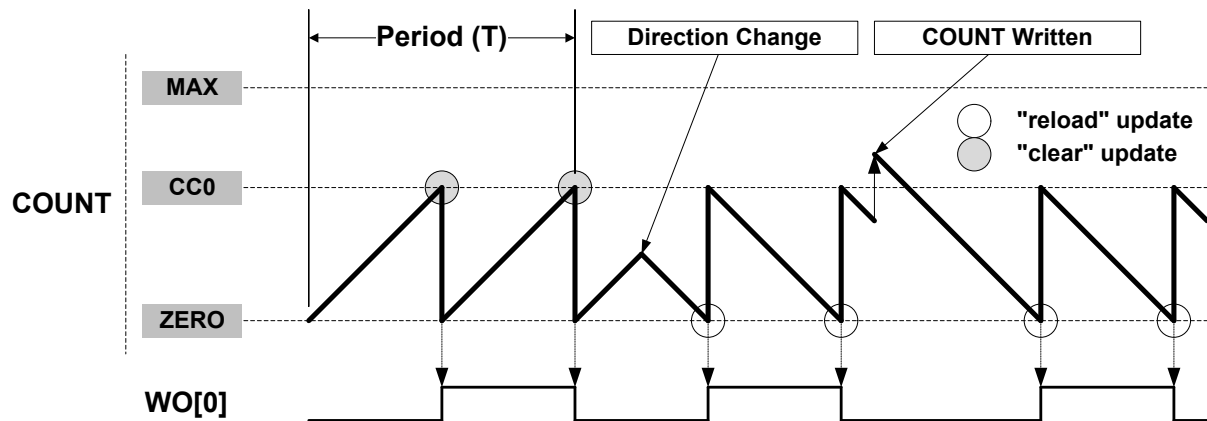
**Figure 44-4.** Normal Frequency Operation



#### Match Frequency Generation (MFRQ)

For Match Frequency Generation, the period time (T) is controlled by the CC0 register instead of PER or MAX. WO[0] toggles on each Update condition.

Figure 44-5. Match Frequency Operation



### Normal Pulse-Width Modulation Operation (NPWM)

NPWM uses single-slope PWM generation.

For single-slope PWM generation, the period time (T) is controlled by the TOP value, and CCx controls the duty cycle of the generated waveform output. When up-counting, the WO[x] is set at start or compare match between the COUNT and TOP values, and cleared on compare match between COUNT and CCx register values. When down-counting, the WO[x] is cleared at start or compare match between the COUNT and ZERO values, and set on compare match between COUNT and CCx register values.

The following equation calculates the exact resolution for a single-slope PWM ( $R_{PWM\_SS}$ ) waveform:

$$R_{PWM\_SS} = \frac{\log(TOP+1)}{\log(2)}$$

The PWM frequency ( $f_{PWM\_SS}$ ) depends on TOP value and the peripheral clock frequency ( $f_{GCLK\_TCx}$ ), and can be calculated by the following equation:

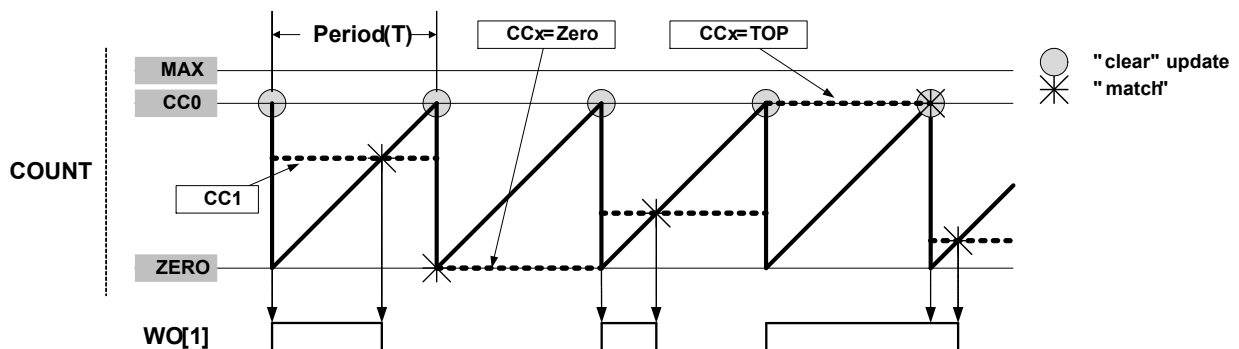
$$f_{PWM\_SS} = \frac{f_{GCLK\_TCx}}{N(TOP+1)}$$

Where N represents the prescaler divider used (1, 2, 4, 8, 16, 64, 256, 1024).

### Match Pulse-Width Modulation Operation (MPWM)

In MPWM, the output of WO[1] is depending on CC1 as shown in the figure below. On every overflow/underflow, a one-TC-clock-cycle negative pulse is put out on WO[0] (not shown in the figure).

Figure 44-6. Match PWM Operation



The table below shows the Update Counter and Overflow Event/Interrupt Generation conditions in different operation modes.

**Table 44-3.** Counter Update and Overflow Event/interrupt Conditions in TC

Name	Operation	TOP	Update	Output Waveform		OVFIF/Event	
				On Match	On Update	Up	Down
NFRQ	Normal Frequency	PER	TOP/ ZERO	Toggle	Stable	TOP	ZERO
MFRQ	Match Frequency	CC0	TOP/ ZERO	Toggle	Stable	TOP	ZERO
NPWM	Single-slope PWM	PER	TOP/ ZERO	See description above.		TOP	ZERO
MPWM	Single-slope PWM	CC0	TOP/ ZERO	Toggle	Toggle	TOP	ZERO

### 44.6.2.7 Double Buffering

The Compare Channels (CCx) registers, and the Period (PER) register in 8-bit mode are double buffered. Each buffer register has a buffer valid bit (CCBUFVx or PERBUFV) in the STATUS register, which indicates that the buffer register contains a new valid value that can be copied into the corresponding register. As long as the respective buffer valid status flag (PERBUFV or CCBUFVx) are set to '1', related syncbusy bits are set (SYNCBUSY.PER or SYNCBUSY.CCx), a write to the respective PER/PERBUF or CCx/CCBUFx registers will generate a PAC error, and access to the respective PER or CCx register is invalid.

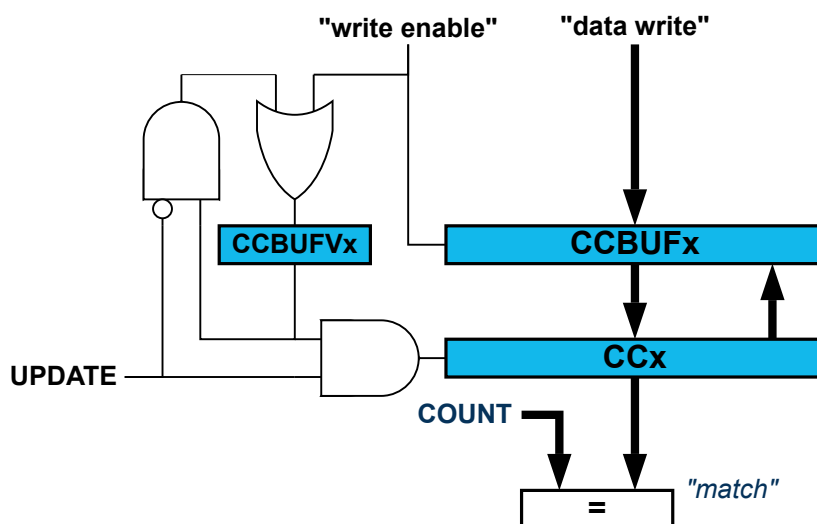
When the buffer valid flag bit in the STATUS register is '1' and the Lock Update bit in the CTRLB register is set to '0', (writing CTRLBCLR.LUPD to '1'), double buffering is enabled: the data from buffer registers will be copied into the corresponding register under hardware UPDATE conditions, then the buffer valid flags bit in the STATUS register are automatically cleared by hardware.

**Notes:**

1. The buffer valid flag bits in the STATUS register can be cleared manually, but must be cleared two times successively.
2. The software update command (CTRLBSET.CMD=0x3) is acting independently of the LUPD value.

A compare register is double buffered as in the following figure.

**Figure 44-7.** Compare Channel Double Buffering



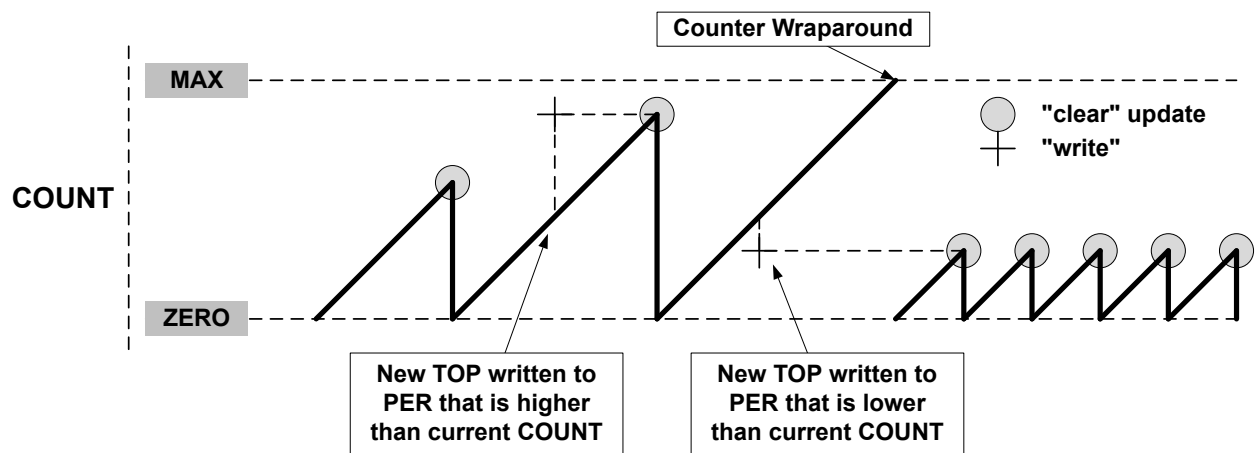
Both the registers (PER/CCx) and corresponding buffer registers (PERBUF/CCBUFx) are available in the I/O register map, and the double buffering feature is not mandatory. The double buffering is disabled by writing a '1' to CTRLBSET.LUPD.

**Note:** In NFRQ, MFRQ or PWM down-counting counter mode (CTRLBSET.DIR=1), when double buffering is enabled (CTRLBCLR.LUPD=1), PERBUF register is continuously copied into the PER independently of update conditions.

### Changing the Period

The counter period can be changed by writing a new TOP value to the Period register (PER or CC0, depending on the waveform generation mode), which is available in 8-bit mode. Any period update on registers (PER or CCx) is effective after the synchronization delay.

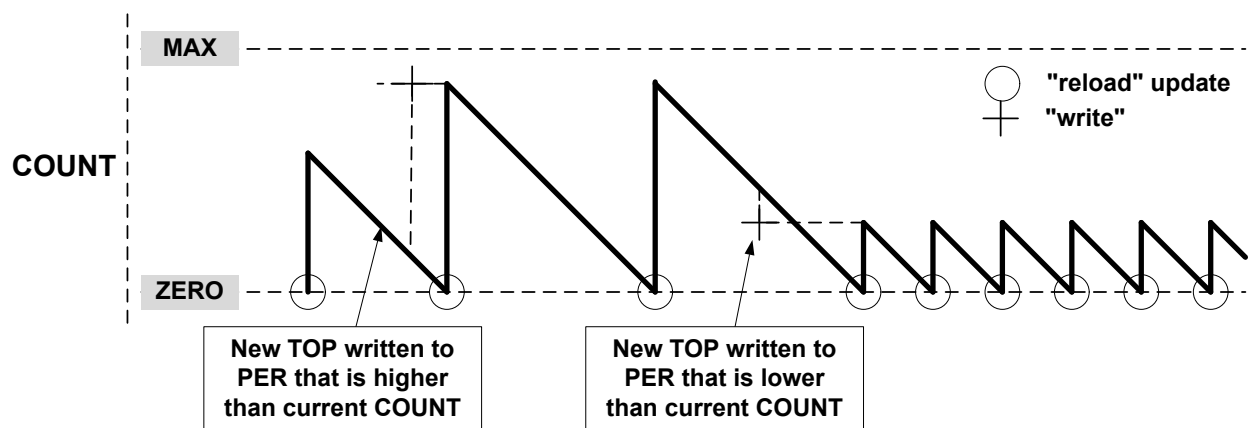
Figure 44-8. Unbuffered Single-Slope Up-Counting Operation



A counter wraparound can occur in any operation mode when up-counting without buffering, see the following figure.

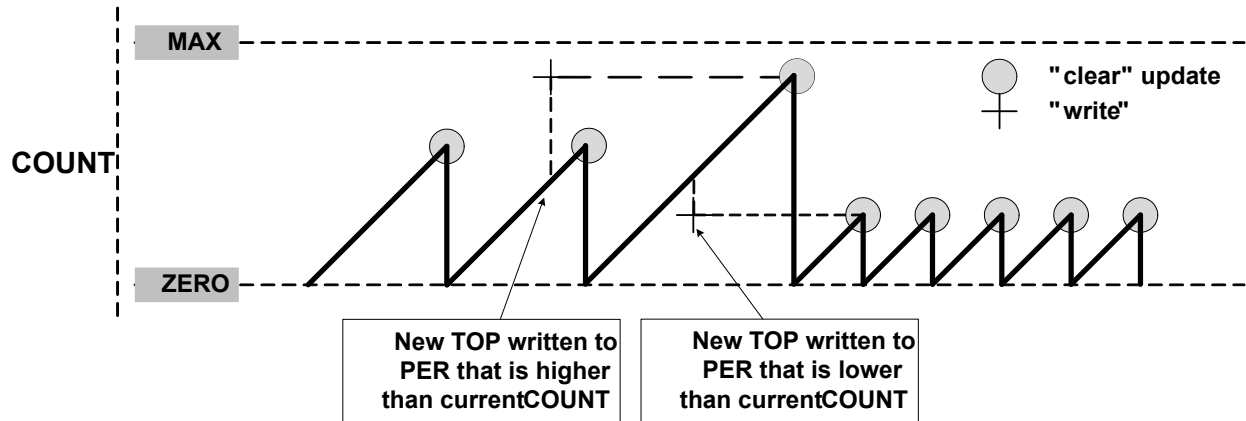
COUNT and TOP are continuously compared, so when a new TOP value that is lower than current COUNT is written to TOP, COUNT will wrap before a compare match.

Figure 44-9. Unbuffered Single-Slope Down-Counting Operation



When double buffering is used, the buffer can be written at any time and the counter will still maintain correct operation. The period register is always updated on the update condition, as shown in the following figure. This prevents wraparound and the generation of odd waveforms.

Figure 44-10. Changing the Period Using Buffering



#### 44.6.2.8 Capture Operations

To enable and use capture operations, the corresponding Capture Channel x Enable bit in the Control A register (CTRLA.CAPTENx) must be written to '1'.

A capture trigger can be provided by input event line TC\_EVU or by asynchronous I/O pin WO[x] for each capture channel or by a TC event. To enable the capture from input event line, Event Input Enable bit in the Event Control register (EVCTRL.TCEI) must be written to '1'. To enable the capture from the I/O pin, the Capture On Pin x Enable bit in the CTRLA register (CTRLA.COPENx) must be written to '1'.

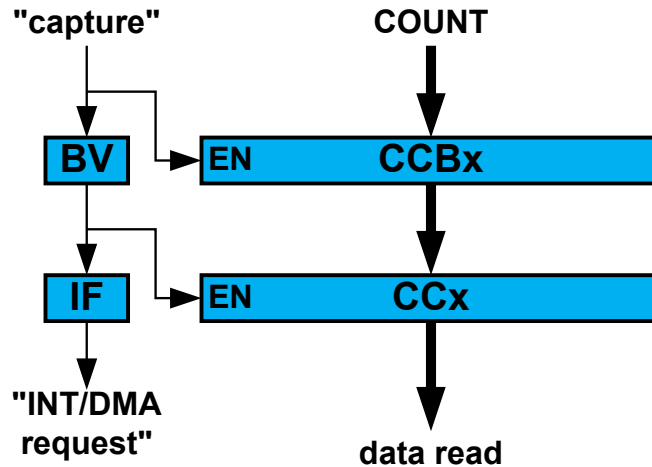
#### Notes:

1. Capture on I/Os is only possible in 'Event' and 'Time-Stamp' capture action modes. Other modes can only use internal events (If I/Os toggling is needed in other modes, then the I/Os edge must be configured for generating internal events).
2. Capture on an event from the Event System is possible in 'Event', 'PPW/PWP/PW', and 'Time-Stamp' capture action modes. In this case, the event system channels must be configured to operate in asynchronous mode of operation.
3. Depending on CTRLA.COPENx, channel x can be configured for I/Os or internal event capture (both are mutually exclusive). One channel can be configured for I/Os capture while the other uses internal event capture.
4. Capture of the period and duty cycle on I/Os using PPW/PWP mode is possible using EIC and Event System.

By default, a capture operation is done when a rising edge is detected on the input signal. Capture on falling edge is available, its activation is depending on the input source:

- When the channel is used with a I/O pin, write a '1' to the corresponding Invert Enable bit in the Drive Control register (DRVCTRL.INVENx).
- When the channel is counting events from the Event System, write a '1' to the TC Event Input Invert Enable bit in Event Control register (EVCTRL.TCINV).

Figure 44-11. Capture Double Buffering



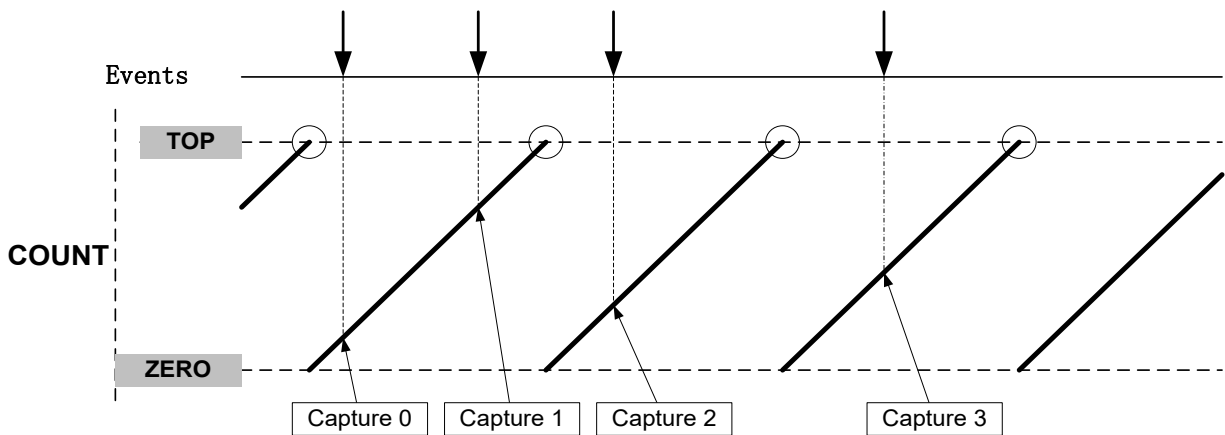
For input capture, the buffer register and the corresponding CCx act like a FIFO. When CCx is empty or read, any content in CCBUFx is transferred to CCx. The buffer valid flag is passed to set the CCx interrupt flag (IF) and generate the optional interrupt, event or DMA request. The CCBUFx register value can't be read, all captured data must be read from the CCx register.

**Note:** When up-counting (CTRLBSET.DIR = 0), counter values lower than '1' cannot be captured. To capture the full range including value 0, the TC must be in down-counting mode (CTRLBSET.DIR = 0).

#### 44.6.2.8.1 Event Capture Action on Events or I/Os

The compare/capture channels can be used as input capture channels to capture events from the Event System or I/O pins and give them a timestamp. This mode is selected when EVTCTRL.EVACT is configured either as OFF, RETRIGGER, COUNT or START. The following figure shows four capture events for one capture channel.

Figure 44-12. Input Capture Timing



The TC can detect capture overflow of the input capture channels: When a new capture event is detected while the Capture Interrupt flag (INTFLAG.MCx) is still set, the new timestamp will not be stored and INTFLAG.ERR will be set.

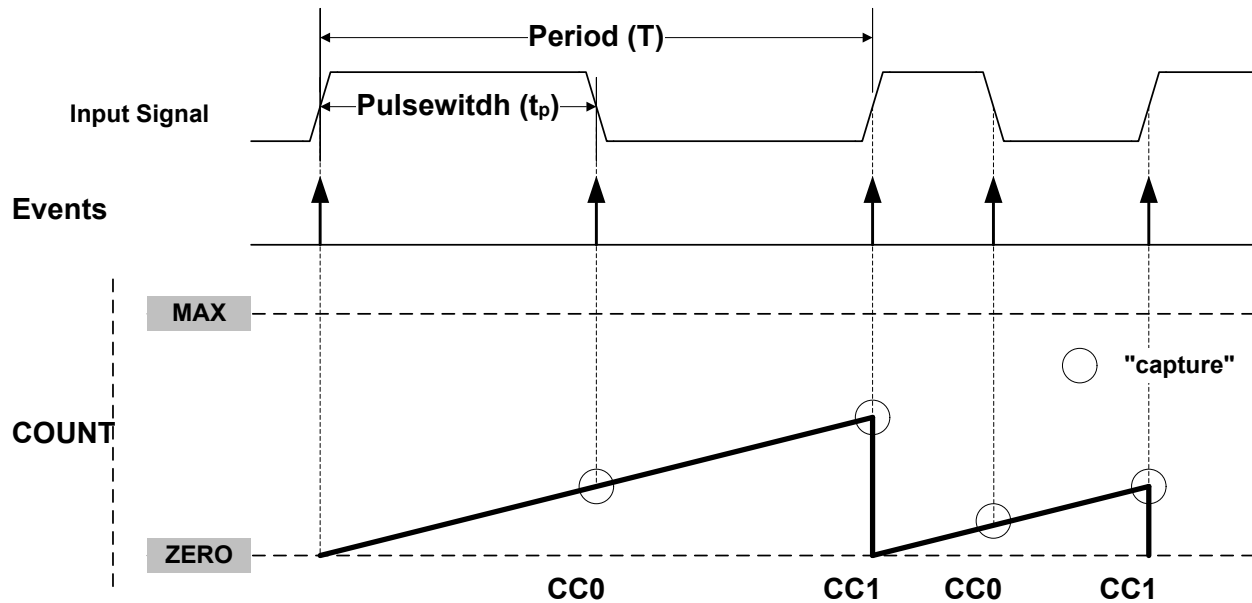
#### 44.6.2.8.2 Period and Pulse-Width (PPW/PWP) Capture Action on Events

The TC can perform two input captures and restart the counter on one of the edges. This enables the TC to measure the pulse width and period and to characterize the frequency  $f$  and duty cycle of an input signal:

$$f = \frac{1}{T}$$

$$\text{dutyCycle} = \frac{t_p}{T}$$

Figure 44-13. PWP Capture



Selecting PWP in the Event Action bit group in the Event Control register (EVCTRL.EVACT) enables the TC to perform one capture action on the rising edge and another one on the falling edge. The period  $T$  will be captured into CC1 and the pulse width  $t_p$  in CC0. EVCTRL.EVACT = PPW (period and pulse-width) offers identical functionality, but will capture  $T$  into CC0 and  $t_p$  into CC1.

The TC Event Input Invert Enable bit in the Event Control register (EVCTRL.TCINV) is used to select whether the wraparound must occur on the rising edge or the falling edge. If EVCTRL.TCINV = 1, the wraparound will happen on the falling edge.

The TC can detect capture overflow of the input capture channels: When a new capture event is detected while the Capture Interrupt flag (INTFLAG.MCx) is still set, the new timestamp will not be stored and INTFLAG.ERR will be set.

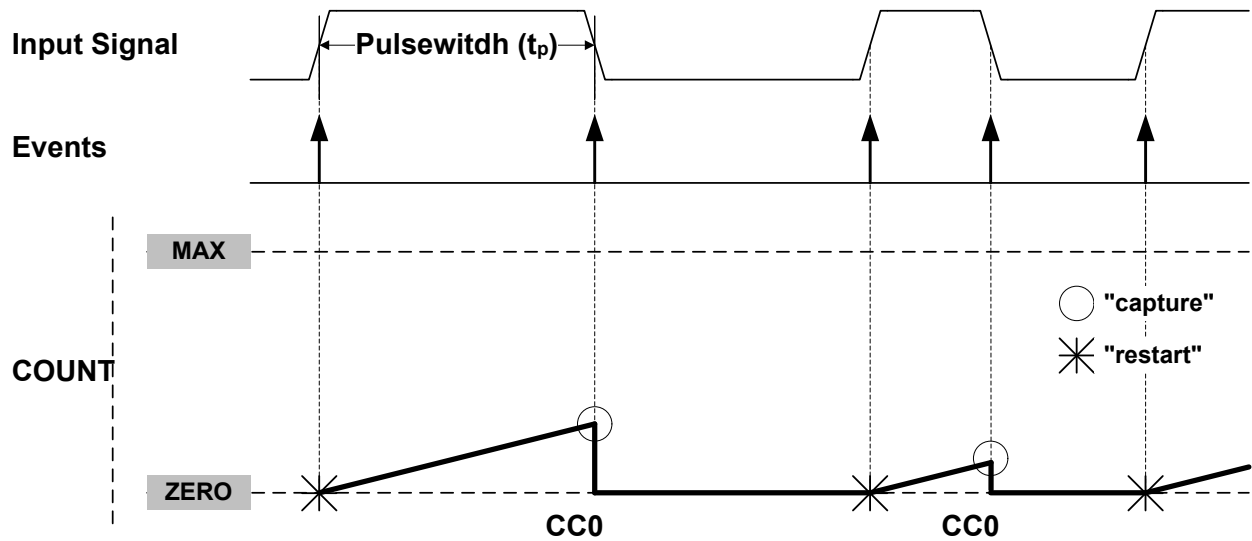
**Note:** The corresponding capture is working only if the channel is enabled in capture mode (CTRLA.CAPTENx = 1). Consequently, both channels must be enabled in order to fully characterize the input.

#### 44.6.2.8.3 Pulse-Width (PW) Capture Action on Events

The TC performs the input capture on the falling edge of the input signal. When the edge is detected, the counter value is cleared and the TC stops counting. When a rising edge is detected on the input signal, the counter restarts the counting operation. To enable the operation on opposite edges, the input signal to capture must be inverted (refer to EVCTRL.TCEINV).



Figure 44-14. Pulse-Width Capture on Channel 0



The TC can detect capture overflow of the input capture channels: When a new capture event is detected while the Capture Interrupt flag (INTFLAG.MCx) is still set, the new timestamp will not be stored and INTFLAG.ERR will be set.

### 44.6.3 Additional Features

#### 44.6.3.1 One-Shot Operation

When one-shot is enabled, the counter automatically stops on the next Counter Overflow or Underflow condition. When the counter is stopped, the Stop bit in the Status register (STATUS.STOP) is automatically set and the waveform outputs are set to zero.

One-shot operation is enabled by writing a '1' to the One-Shot bit in the Control B Set register (CTRLBSET.ONESHOT), and disabled by writing a '1' to CTRLBCLR.ONESHOT. When enabled, the TC will count until an overflow or underflow occurs and stops counting operation. The one-shot operation can be restarted by a re-trigger software command, a re-trigger event, or a start event. When the counter restarts its operation, STATUS.STOP is automatically cleared.

#### 44.6.3.2 Time-Stamp Capture on Events or I/Os

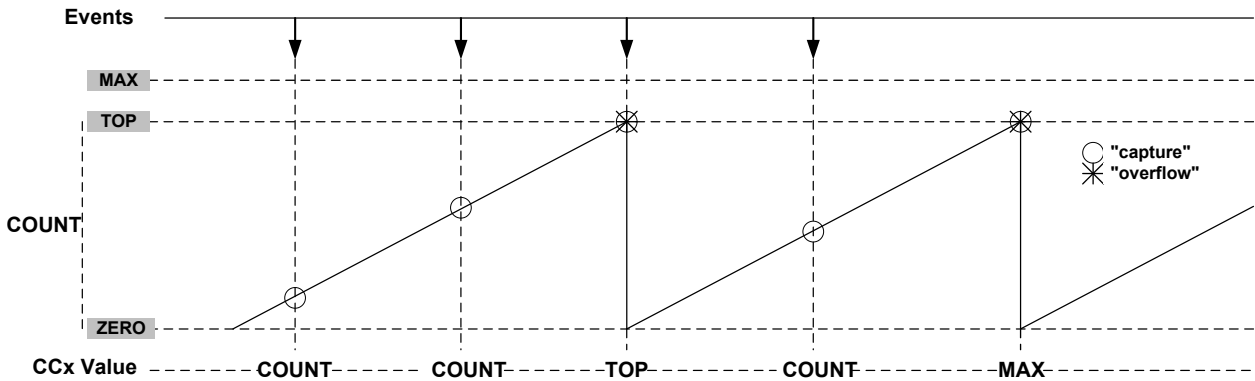
This feature is enabled when the Capture Time Stamp (STAMP) Event Action in Event Control register (EVCTRL.EVACT) is selected. The counter TOP value must be smaller than MAX.

When a capture event is detected from the Event System or the I/O pin, the COUNT value is copied into the corresponding Channel x Compare/Capture Value (CCx) register. In case of an overflow, the MAX value is copied into the corresponding CCx register.

When a valid captured value is present in the capture channel register, the corresponding Capture Channel x Interrupt Flag (INTFLAG.MCx) is set.

The timer/counter can detect capture overflow of the input capture channels: When a new capture event is detected while the Capture Channel interrupt flag (INTFLAG.MCx) is still set, the new time-stamp will not be stored and INTFLAG.ERR will be set.

Figure 44-15. Time-Stamp



#### 44.6.3.3 Minimum Capture

The minimum capture is enabled by writing the CAPTMIN mode in the Channel n Capture Mode bits in the Control A register (CTRLA.CAPTMODEn = CAPTMIN).

##### CCx Content:

In CAPTMIN operations, CCx keeps the Minimum captured values. Before enabling this mode of capture, the user must initialize the corresponding CCx register value to a value different from zero. If the CCx register initial value is zero, no captures will be performed using the corresponding channel.

##### MCx Behaviour:

In CAPTMIN operation, capture is performed only when on capture event time, the counter value is lower than the last captured value. The MCx interrupt flag is set only when on capture event time, the counter value is upper or equal to the value captured on the previous event. So interrupt flag is set when a new absolute local Minimum value has been detected.

#### 44.6.3.4 Maximum Capture

The maximum capture is enabled by writing the CAPTMAX mode in the Channel n Capture Mode bits in the Control A register (CTRLA.CAPTMODEn = CAPTMAX).

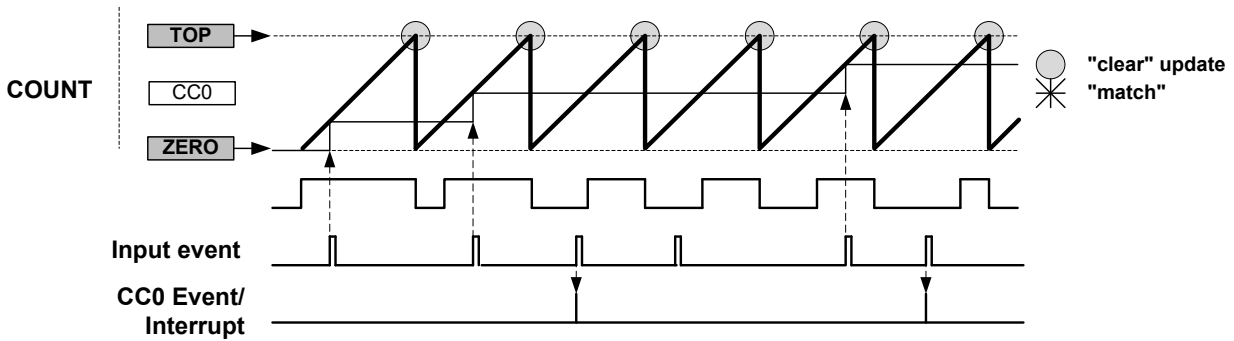
##### CCx Content:

In CAPTMAX operations, CCx keeps the Maximum captured values. Before enabling this mode of capture, the user must initialize the corresponding CCx register value to a value different from TOP. If the CCx register initial value is TOP, no captures will be performed using the corresponding channel.

##### MCx Behaviour:

In CAPTMAX operation, capture is performed only when on capture event time, the counter value is upper than the last captured value. The MCx interrupt flag is set only when on capture event time, the counter value is lower or equal to the value captured on the previous event. So interrupt flag is set when a new absolute local Maximum value has been detected.

Figure 44-16. Maximum Capture Operation with CC0 Initialized with ZERO Value



#### 44.6.4 DMA Operation

The TC can generate the following DMA requests:

- Overflow (OVF): the request is set when an update condition (overflow, underflow or re-trigger) is detected, the request is cleared by hardware on DMA acknowledge.
- Match or Capture Channel x (MCx): for a compare channel, the request is set on each compare match detection, the request is cleared by hardware on DMA acknowledge. For a capture channel, the request is set when valid data is present in the CCx register, and cleared when CCx register is read.

#### 44.6.5 Interrupts

The TC has the following interrupt sources:

- Overflow/Underflow (OVF)
- Match or Capture Channel x (MCx)
- Capture Overflow Error (ERR)

Each interrupt source has an interrupt flag associated with it. The interrupt flag in the Interrupt Flag Status and Clear register (INTFLAG) is set when the interrupt condition occurs.

Each interrupt can be individually enabled by writing a '1' to the corresponding bit in the Interrupt Enable Set register (INTENSET), and disabled by writing a '1' to the corresponding bit in the Interrupt Enable Clear register (INTENCLR). The status of enabled interrupts can be read from either INTENSET or INTENCLR.

An interrupt request is generated when the interrupt flag is set and the corresponding interrupt is enabled. The interrupt request remains active until either the interrupt flag is cleared, the interrupt is disabled, or the TC is reset. See [INTFLAG](#) for details on how to clear interrupt flags.

The TC has one common interrupt request line for all the interrupt sources. The user must read the INTFLAG register to determine which interrupt condition is present.

Note that interrupts must be globally enabled for interrupt requests to be generated. Refer to [Nested Vector Interrupt Controller](#) for details.

#### 44.6.6 Events

The TC can generate the following output events:

- Overflow/Underflow (OVF)
- Match or Capture Channel x (MCX0-1)

Writing a '1' to an Event Output bit in the Event Control register (EVCTRL.MCEOx) enables the corresponding output event. The output event is disabled by writing EVCTRL.MCEOx=0.

One of the following event actions can be selected by the Event Action bit group in the Event Control register (EVCTRL.EVACT):

- Disable event action (OFF)
- Start TC (START)
- Re-trigger TC (RETRIGGER)
  - If a re-trigger event occurs exactly at the time a Channel Compare Match occurs, the next waveform will be corrupted. To avoid this issue, use two channels to store two successive CC register values (n and n+1) and combine the related waveform outputs to provide signal redundancy.
- Count on event (COUNT)
- Capture time stamp (STAMP)
- Capture Period (PPW and PWP)
- Capture Pulse Width (PW)

Writing a '1' to the TC Event Input bit in the Event Control register (EVCTRL.TCEI) enables input events (EVU0-2) to the TC. Writing a '0' to this bit disables input events to the TC. The TC requires only asynchronous event inputs. For additional information on configuring the asynchronous events, refer to the section [EVSYS - Event System](#).

#### 44.6.7 Sleep Mode Operation

The TC can be configured to operate in any sleep mode. To be able to run in standby, the RUNSTDBY bit in the Control A register (CTRLA.RUNSTDBY) must be '1'. This peripheral can wake up the device from any sleep mode using interrupts or perform actions through the Event System.

If the On Demand bit in the Control A register (CTRLA.ONDEMAND) is written to '1', the module stops requesting its peripheral clock when the STOP bit in STATUS register (STATUS.STOP) is set to '1'. When a re-trigger or start condition is detected, the TC requests the clock before the operation starts.

#### 44.6.8 Synchronization

Due to asynchronicity between the main clock domain and the peripheral clock domains, some registers need to be synchronized when written or read.

The following bits are synchronized when written:

- Software Reset and Enable bits in Control A register (CTRLA.SWRST and CTRLA.ENABLE)
- Capture Channel Buffer Valid bit in STATUS register (STATUS.CCBUFVx)

The following registers are synchronized when written:

- Control B Clear and Control B Set registers (CTRLBCLR and CTRLBSET)
- Count Value register (COUNT)
- Period Value and Period Buffer Value registers (PER and PERBUF)
- Channel x Compare/Capture Value and Channel x Compare/Capture Buffer Value registers (CCx and CCBUFx)

The following registers are synchronized when read:

- Count Value register (COUNT): synchronization is done on demand through READSYNC command (CTRLBSET.CMD)
- Control B Clear and Control B Set registers (CTRLBCLR and CTRLBSET)
- Channel x Compare/Capture Value (CCx)

Required write synchronization is denoted by the "Write-Synchronized" property in the register description.

Required read synchronization is denoted by the "Read-Synchronized" property in the register description.

## 44.7 Register Summary - 8-bit Mode

Offset	Name	Bit Pos.	7	6	5	4	3	2	1	0	
0x00	CTRLA	7:0	ONDEMAND	RUNSTDBY	PRESCSYNC[1:0]		MODE[1:0]		ENABLE	SWRST	
		15:8					ALOCK	PRESCALER[2:0]			
		23:16			COPEN1	COPEN0			CAPTEN1	CAPTEN0	
		31:24				CAPTMODE1[1:0]			CAPTMODE0[1:0]		
0x04	CTRLBCLR	7:0	CMD[2:0]					ONESHOT	LUPD	DIR	
0x05	CTRLBSET	7:0	CMD[2:0]					ONESHOT	LUPD	DIR	
0x06	EVCTRL	7:0			TCEI	TCINV		EVACT[2:0]			
		15:8			MCEO1	MCEO0				OVFEO	
0x08	INTENCLR	7:0			MC1	MC0			ERR	OVF	
0x09	INTENSET	7:0			MC1	MC0			ERR	OVF	
0x0A	INTFLAG	7:0			MC1	MC0			ERR	OVF	
0x0B	STATUS	7:0			CCBUFV1	CCBUFV0	PERBUFV		SLAVE	STOP	
0x0C	WAVE	7:0							WAVEGEN[1:0]		
0x0D	DRVCTRL	7:0							INVEN1	INVEN0	
0x0E	Reserved										
0x0F	DBGCTRL	7:0								DBGRUN	
0x10	SYNCBUSY	7:0	CC1	CC0	PER	COUNT	STATUS	CTRLB	ENABLE	SWRST	
		15:8									
		23:16									
		31:24									
0x14	COUNT	7:0	COUNT[7:0]								
0x15	Reserved										
...											
0x1A											
0x1B	PER	7:0	PER[7:0]								
0x1C	CC0	7:0	CC[7:0]								
0x1D	CC1	7:0	CC[7:0]								
0x1E	Reserved										
...											
0x2E											
0x2F	PERBUF	7:0	PERBUF[7:0]								
0x30	CCBUF0	7:0	CCBUF[7:0]								
0x31	CCBUF1	7:0	CCBUF[7:0]								

### 44.7.1 Control A

**Name:** CTRLA  
**Offset:** 0x00  
**Reset:** 0x00000000  
**Property:** PAC Write-Protection, Write-Synchronized Bits, Enable-Protected Bits

Bit	31	30	29	28	27	26	25	24
			CAPTMODE1[1:0]				CAPTMODE0[1:0]	
Access			R/W	R/W			R/W	R/W
Reset			0	0			0	0
Bit	23	22	21	20	19	18	17	16
			COPEN1	COPEN0			CAPTEN1	CAPTEN0
Access			R/W	R/W			R/W	R/W
Reset			0	0			0	0
Bit	15	14	13	12	11	10	9	8
					ALOCK	PRESCALER[2:0]		
Access					R/W	R/W	R/W	R/W
Reset					0	0	0	0
Bit	7	6	5	4	3	2	1	0
	ONDEMAND	RUNSTDBY	PRESCSYNC[1:0]		MODE[1:0]		ENABLE	SWRST
Access	R/W	R/W	R/W	R/W	R/W	R/W	R/W	W
Reset	0	0	0	0	0	0	0	0

#### Bits 28:27 – CAPTMODE1[1:0] Capture mode Channel 1

These bits select the channel 1 capture mode.

Value	Name	Description
0x0	DEFAULT	Default capture
0x1	CAPTMIN	Minimum capture
0x2	CAPTMAX	Maximum capture
0x3	—	Reserved

#### Bits 25:24 – CAPTMODE0[1:0] Capture mode Channel 0

These bits select the channel 0 capture mode.

Value	Name	Description
0x0	DEFAULT	Default capture
0x1	CAPTMIN	Minimum capture
0x2	CAPTMAX	Maximum capture
0x3	—	Reserved

#### Bits 20, 21 – COPENx Capture On Pin x Enable

Bit x of COPEN[1:0] selects the trigger source for capture operation, either events or I/O pin input. This bit is not synchronized.

Value	Description
0	Event from Event System is selected as trigger source for capture operation on channel x.
1	I/O pin is selected as trigger source for capture operation on channel x.

#### Bits 16, 17 – CAPTENx Capture Channel x Enable

Bit x of CAPTEN[1:0] selects whether channel x is a capture or a compare channel. These bits are not synchronized.

Value	Description
0	CAPTEN disables capture on channel x.
1	CAPTEN enables capture on channel x.

#### Bit 11 – ALOCK Auto Lock

When this bit is set, Lock bit update (LUPD) is set to '1' on each overflow/underflow or re-trigger event.

This bit is not synchronized.

Value	Description
0	The LUPD bit is not affected on overflow/underflow, and re-trigger event.
1	The LUPD bit is set on each overflow/underflow or re-trigger event.

#### Bits 10:8 – PRESCALER[2:0] Prescaler

These bits select the counter prescaler factor.

These bits are not synchronized.

Value	Name	Description
0x0	DIV1	Prescaler: GCLK_TC
0x1	DIV2	Prescaler: GCLK_TC/2
0x2	DIV4	Prescaler: GCLK_TC/4
0x3	DIV8	Prescaler: GCLK_TC/8
0x4	DIV16	Prescaler: GCLK_TC/16
0x5	DIV64	Prescaler: GCLK_TC/64
0x6	DIV256	Prescaler: GCLK_TC/256
0x7	DIV1024	Prescaler: GCLK_TC/1024

#### Bit 7 – ONDEMAND Clock On Demand

This bit selects the clock requirements when the TC is stopped.

In standby mode, if the Run in Standby bit (CTRLA.RUNSTDBY) is '0', ONDEMAND is forced to '0'.

This bit is not synchronized.

Value	Description
0	The On Demand is disabled. If On Demand is disabled, the TC will continue to request the clock when its operation is stopped (STATUS.STOP=1).
1	The On Demand is enabled. When On Demand is enabled, the stopped TC will not request the clock. The clock is requested when a software re-trigger command is applied or when an event with start/re-trigger action is detected.

#### Bit 6 – RUNSTDBY Run in Standby

This bit is used to keep the TC running in standby mode.

This bit is not synchronized.

Value	Description
0	The TC is halted in standby.
1	The TC continues to run in standby.

#### Bits 5:4 – PRESCSYNC[1:0] Prescaler and Counter Synchronization

These bits select whether the counter should wrap around on the next GCLK\_TCx clock or the next prescaled GCLK\_TCx clock. It also makes it possible to reset the prescaler.

These bits are not synchronized.

Value	Name	Description
0x0	GCLK	Reload or reset the counter on next generic clock
0x1	PRESC	Reload or reset the counter on next prescaler clock
0x2	RESYNC	Reload or reset the counter on next generic clock. Reset the prescaler counter
0x3	-	Reserved

#### Bits 3:2 – MODE[1:0] Timer Counter Mode

These bits select the counter mode.

These bits are not synchronized.



Value	Name	Description
0x0	COUNT16	Counter in 16-bit mode
0x1	COUNT8	Counter in 8-bit mode
0x2	COUNT32	Counter in 32-bit mode
0x3	-	Reserved

**Bit 1 – ENABLE** Enable

Due to synchronization, there is delay from writing CTRLA.ENABLE until the peripheral is enabled/disabled. The value written to CTRLA.ENABLE will read back immediately, and the ENABLE Synchronization Busy bit in the SYNCBUSY register (SYNCBUSY.ENABLE) will be set. SYNCBUSY.ENABLE will be cleared when the operation is complete. This bit is not enable-protected.

Value	Description
0	The peripheral is disabled.
1	The peripheral is enabled.

**Bit 0 – SWRST** Software Reset

Writing a '0' to this bit has no effect.

Writing a '1' to this bit resets all registers in the TC, except DBGCTRL, to their initial state, and the TC will be disabled.

Writing a '1' to CTRLA.SWRST will always take precedence; all other writes in the same write-operation will be discarded.

**Notes:**

1. When the CTRLA.SWRST is written, the user must poll the SYNCBUSY.SWRST bit to know when the reset operation is complete.
2. During a SWRST, access to registers/bits without the SWRST are disallowed until the SYNCBUSY.SWRST is cleared by hardware.
3. This bit is not Enable-Protected.

## 44.7.2 Control B Clear

**Name:** CTRLBCLR  
**Offset:** 0x04  
**Reset:** 0x00  
**Property:** PAC Write-Protection, Read-Synchronized, Write-Synchronized

**Note:** This register is read- synchronized and write-synchronized: SYNCBUSY.CTRLB must be checked to ensure the CTRLBCLR register synchronization is complete.

This register allows the user to clear bits in the CTRLB register without doing a read-modify-write operation. Changes in this register will also be reflected in the Control B Set register (CTRLBSET).

Bit	7	6	5	4	3	2	1	0
	CMD[2:0]					ONESHOT	LUPD	DIR
Access	R/W	R/W	R/W			R/W	R/W	R/W
Reset	0	0	0			0	0	0

### Bits 7:5 – CMD[2:0] Command

Writing a '0' to these bits has no effect.

Writing a '1' to any of these bits will clear the pending command.

### Bit 2 – ONESHOT One-Shot on Counter

This bit controls one-shot operation of the TC.

Writing a '0' to this bit has no effect

Writing a '1' to this bit will disable one-shot operation.

Value	Description
0	The TC will wrap around and continue counting on an overflow/underflow condition.
1	The TC will wrap around and stop on the next underflow/overflow condition.

### Bit 1 – LUPD Lock Update

This bit controls the update operation of the TC buffered registers.

When CTRLB.LUPD is set, no any update of the registers with value of its buffered register is performed on hardware UPDATE condition. Locking the update ensures that all buffer registers are valid before an hardware update is performed. After all the buffer registers are loaded correctly, the buffered registers can be unlocked.

This bit has no effect when input capture operation is enabled.

Writing a '0' to this bit has no effect.

Writing a '1' to this bit will clear the LUPD bit.

Value	Description
0	The CCBUFx and PERBUF buffer registers value are copied into CCx and PER registers on hardware update condition.
1	The CCBUFx and PERBUF buffer registers value are not copied into CCx and PER registers on hardware update condition.

### Bit 0 – DIR Counter Direction

This bit is used to change the direction of the counter.

Writing a '0' to this bit has no effect.

Writing a '1' to this bit will clear the bit and make the counter count up.

Value	Description
0	The timer/counter is counting up (incrementing).
1	The timer/counter is counting down (decrementing).

### 44.7.3 Control B Set

**Name:** CTRLBSET  
**Offset:** 0x05  
**Reset:** 0x00  
**Property:** PAC Write-Protection, Write-Synchronized

**Note:** This register is write-synchronized: SYNCBUSY.CTRLB must be checked to ensure the CTRLBCLR register synchronization is complete.

This register allows the user to set bits in the CTRLB register without doing a read-modify-write operation. Changes in this register will also be reflected in the Control B Clear register (CTRLBCLR).

Bit	7	6	5	4	3	2	1	0
	CMD[2:0]					ONESHOT	LUPD	DIR
Access	R/W	R/W	R/W			R/W	R/W	R/W
Reset	0	0	0			0	0	0

#### Bits 7:5 – CMD[2:0] Command

These bits are used for software control of the TC. The commands are executed on the next prescaled GCLK\_TCx clock cycle. When a command has been executed, the CMD bit group will be read back as zero.

Writing 0x0 to these bits has no effect.

Writing a value different from 0x0 to this bit field will issue a command for execution.



**Important:** This command requires synchronization before being executed. A valid sequence is as follows:

- Issue CMD command (CTRLBSET.CMD = command)
- Wait for CMD synchronization (SYNCBUSY.CTRLB = 0)
- Wait for CMD read back as zero (CTRLBSET.CMD = 0)

Value	Name	Description
0x0	NONE	No action
0x1	RETRIGGER	Force a start, restart or retrigger
0x2	STOP	Force a stop
0x3	UPDATE	Force update of double buffered registers
0x4	READSYNC	Force a read synchronization of COUNT

#### Bit 2 – ONESHOT One-Shot on Counter

This bit controls one-shot operation of the TC.

Writing a '0' to this bit has no effect.

Writing a '1' to this bit will enable one-shot operation.

Value	Description
0	The TC will wrap around and continue counting on an overflow/underflow condition.
1	The TC will wrap around and stop on the next underflow/overflow condition.

#### Bit 1 – LUPD Lock Update

This bit controls the update operation of the TC buffered registers.

When CTRLB.LUPD is set, no any update of the registers with value of its buffered register is performed on hardware UPDATE condition. Locking the update ensures that all buffer registers are valid before an hardware update is performed. After all the buffer registers are loaded correctly, the buffered registers can be unlocked.

Writing a '0' to this bit has no effect.

Writing a '1' to this bit will set the LUPD bit.  
 This bit has no effect when input capture operation is enabled.

Value	Description
0	The CCBUFx and PERBUF buffer registers value are copied into CCx and PER registers on hardware update condition.
1	The CCBUFx and PERBUF buffer registers value are not copied into CCx and PER registers on hardware update condition.

**Bit 0 – DIR** Counter Direction

This bit is used to change the direction of the counter.  
 Writing a '0' to this bit has no effect  
 Writing a '1' to this bit will clear the bit and make the counter count up.

Value	Description
0	The timer/counter is counting up (incrementing).
1	The timer/counter is counting down (decrementing).

#### 44.7.4 Event Control

**Name:** EVCTRL  
**Offset:** 0x06  
**Reset:** 0x0000  
**Property:** PAC Write-Protection, Enable-Protected

Bit	15	14	13	12	11	10	9	8
			MCEO1	MCEO0				OVFEO
Access			R/W	R/W				R/W
Reset			0	0				0
Bit	7	6	5	4	3	2	1	0
			TCEI	TCINV		EVACTION[2:0]		
Access			R/W	R/W		R/W	R/W	R/W
Reset			0	0		0	0	0

#### Bits 12, 13 – MCEOX Match or Capture Channel x Event Output Enable [x = 1..0]

These bits enable the generation of an event for every match or capture on channel x.

Value	Description
0	Match/Capture event on channel x is disabled and will not be generated.
1	Match/Capture event on channel x is enabled and will be generated for every compare/capture.

#### Bit 8 – OVFEO Overflow/Underflow Event Output Enable

This bit enables the Overflow/Underflow event. When enabled, an event will be generated when the counter overflows/underflows.

Value	Description
0	Overflow/Underflow event is disabled and will not be generated.
1	Overflow/Underflow event is enabled and will be generated for every counter overflow/underflow.

#### Bit 5 – TCEI TC Event Enable

This bit is used to enable asynchronous input events to the TC.

Value	Description
0	Incoming events are disabled.
1	Incoming events are enabled.

#### Bit 4 – TCINV TC Inverted Event Input Polarity

This bit inverts the asynchronous input event source.

Value	Description
0	Input event source is not inverted.
1	Input event source is inverted.

#### Bits 2:0 – EVACTION[2:0] Event Action

These bits define the event action the TC will perform on an event.

Value	Name	Description
0x0	OFF	Event action disabled
0x1	RETRIGGER	Start, restart or retrigger TC on event
0x2	COUNT	Count on event
0x3	START	Start TC on event
0x4	STAMP	Time stamp capture
0x5	PPW	Period captured in CC0, pulse width in CC1
0x6	PWP	Period captured in CC1, pulse width in CC0
0x7	PW	Pulse width capture

### 44.7.5 Interrupt Enable Clear

**Name:** INTENCLR  
**Offset:** 0x08  
**Reset:** 0x00  
**Property:** PAC Write-Protection

This register allows the user to disable an interrupt without doing a read-modify-write operation. Changes in this register will also be reflected in the Interrupt Enable Set register (INTENSET).

Bit	7	6	5	4	3	2	1	0
			MC1	MC0			ERR	OVF
Access			R/W	R/W			R/W	R/W
Reset			0	0			0	0

#### Bits 4, 5 – MCx Match or Capture Channel x Interrupt Enable

Writing a '0' to these bits has no effect.

Writing a '1' to MCx will clear the corresponding Match or Capture Channel x Interrupt Enable bit, which disables the Match or Capture Channel x interrupt.

Value	Description
0	The Match or Capture Channel x interrupt is disabled.
1	The Match or Capture Channel x interrupt is enabled.

#### Bit 1 – ERR Error Interrupt Disable

Writing a '0' to this bit has no effect.

Writing a '1' to this bit will clear the Error Interrupt Enable bit, which disables the Error interrupt.

Value	Description
0	The Error interrupt is disabled.
1	The Error interrupt is enabled.

#### Bit 0 – OVF Overflow Interrupt Disable

Writing a '0' to this bit has no effect.

Writing a '1' to this bit will clear the Overflow Interrupt Enable bit, which disables the Overflow interrupt request.

Value	Description
0	The Overflow interrupt is disabled.
1	The Overflow interrupt is enabled.

## 44.7.6 Interrupt Enable Set

**Name:** INTENSET  
**Offset:** 0x09  
**Reset:** 0x00  
**Property:** PAC Write-Protection

This register allows the user to enable an interrupt without doing a read-modify-write operation. Changes in this register will also be reflected in the Interrupt Enable Clear register (INTENCLR).

Bit	7	6	5	4	3	2	1	0
			MC1	MC0			ERR	OVF
Access			R/W	R/W			R/W	R/W
Reset			0	0			0	0

### Bits 4, 5 – MCx Match or Capture Channel x Interrupt Enable

Writing a '0' to these bits has no effect.

Writing a '1' to MCx will clear the corresponding Match or Capture Channel x Interrupt Enable bit, which disables the Match or Capture Channel x interrupt.

Value	Description
0	The Match or Capture Channel x interrupt is disabled.
1	The Match or Capture Channel x interrupt is enabled.

### Bit 1 – ERR Error Interrupt Enable

Writing a '0' to this bit has no effect.

Writing a '1' to this bit will set the Error Interrupt Enable bit, which enables the Error interrupt.

Value	Description
0	The Error interrupt is disabled.
1	The Error interrupt is enabled.

### Bit 0 – OVF Overflow Interrupt Enable

Writing a '0' to this bit has no effect.

Writing a '1' to this bit will set the Overflow Interrupt Enable bit, which enables the Overflow interrupt request.

Value	Description
0	The Overflow interrupt is disabled.
1	The Overflow interrupt is enabled.

### 44.7.7 Interrupt Flag Status and Clear

**Name:** INTFLAG  
**Offset:** 0x0A  
**Reset:** 0x00  
**Property:** -

Bit	7	6	5	4	3	2	1	0
			MC1	MC0			ERR	OVF
Access			R/W	R/W			R/W	R/W
Reset			0	0			0	0

#### Bits 4, 5 – MCx Match or Capture Channel x

This flag is set on a comparison match, or when the corresponding CCx register contains a valid capture value. This flag is set on the next CLK\_TC\_CNT cycle, and will generate an interrupt request if the corresponding Match or Capture Channel x Interrupt Enable bit in the Interrupt Enable Set register (INTENSET.MCx) is '1'.

Writing a '0' to one of these bits has no effect.

Writing a '1' to one of these bits will clear the corresponding Match or Capture Channel x interrupt flag

In capture operation, this flag is automatically cleared when CCx register is read.

#### Bit 1 – ERR Error Interrupt Flag

This flag is set when a new capture occurs on a channel while the corresponding Match or Capture Channel x interrupt flag is set, in which case there is nowhere to store the new capture.

Writing a '0' to this bit has no effect.

Writing a '1' to this bit clears the Error interrupt flag.

#### Bit 0 – OVF Overflow Interrupt Flag

This flag is set on the next CLK\_TC\_CNT cycle after an overflow condition occurs, and will generate an interrupt request if INTENCLR.OVF or INTENSET.OVF is '1'.

Writing a '0' to this bit has no effect.

Writing a '1' to this bit clears the Overflow interrupt flag.



#### 44.7.8 Status

**Name:** STATUS  
**Offset:** 0x0B  
**Reset:** 0x01  
**Property:** Read-Synchronized, Write-Synchronized

**Note:** This register is read- and write-synchronized: SYNCBUSY.STATUS must be checked to ensure the STATUS register synchronization is complete.

Bit	7	6	5	4	3	2	1	0
			CCBUFV1	CCBUFV0	PERBUFV		SLAVE	STOP
Access			R/W	R/W	R/W		R	R
Reset			0	0	0		0	1

##### Bits 4, 5 – CCBUFVx Channel x Compare or Capture Buffer Valid

For a compare channel x, the bit x is set when a new value is written to the corresponding CCBUFx register.

The bit x is cleared by writing a '1' to it when CTRLB.LUPD is set, or it is cleared automatically by hardware on UPDATE condition.

**Note:** If clearing this bit manually to force an update of the CCx register, it is necessary to clear the bit two times successively.

For a capture channel x, the bit x is set when a valid capture value is stored in the CCBUFx register. The bit x is cleared automatically when the CCx register is read.

##### Bit 3 – PERBUFV Period Buffer Valid

This bit is set when a new value is written to the PERBUF register. The bit is cleared by writing '1' to the corresponding location when CTRLB.LUPD is set, or automatically cleared by hardware on UPDATE condition. This bit is available only in 8-bit mode and will always read zero in 16- and 32-bit modes.

**Note:** If clearing this bit manually to force an update of the PER register, it is necessary to clear the bit two times successively.

##### Bit 1 – SLAVE Client Status Flag

This bit is only available in 32-bit mode on the Client TC (i.e., TC1 and/or TC3). The bit is set when the associated Host TC (TC0 and TC2, respectively) is set to run in 32-bit mode.

##### Bit 0 – STOP Stop Status Flag

This bit is set when the TC is disabled, on a Stop command, or on an overflow/underflow condition when the One-Shot bit in the Control B Set register (CTRLBSET.ONESHOT) is '1'.

Value	Description
0	Counter is running.
1	Counter is stopped.

### 44.7.9 Waveform Generation Control

**Name:** WAVE  
**Offset:** 0x0C  
**Reset:** 0x00  
**Property:** PAC Write-Protection, Enable-Protected

Bit	7	6	5	4	3	2	1	0
							WAVEGEN[1:0]	
Access							R/W	R/W
Reset							0	0

#### Bits 1:0 – WAVEGEN[1:0] Waveform Generation Mode

These bits select the waveform generation operation. They affect the top value, as shown in [44.6.2.6.1. Waveform Output Operations](#). They also control whether frequency or PWM waveform generation should be used. The waveform generation operations are explained in [44.6.2.6.1. Waveform Output Operations](#).

Value	Name	Operation	Top Value	Output Waveform on Match	Output Waveform on Wraparound
0x0	NFRQ	Normal frequency	PER <sup>1</sup> / Max	Toggle	No action
0x1	MFRQ	Match frequency	CC0	Toggle	No action
0x2	NPWM	Normal PWM	PER <sup>1</sup> / Max	Set	Clear
0x3	MPWM	Match PWM	CC0	Set	Clear

1) This depends on the TC mode: In 8-bit mode, the top value is the Period Value register (PER). In 16- and 32-bit mode it is the respective MAX value.

#### 44.7.10 Driver Control

**Name:** DRVCTRL  
**Offset:** 0x0D  
**Reset:** 0x00  
**Property:** PAC Write-Protection, Enable-Protected

Bit	7	6	5	4	3	2	1	0
							INVEN1	INVEN0
Access							R/W	R/W
Reset							0	0

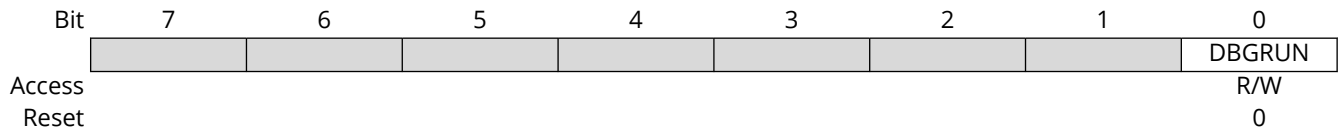
#### Bits 0, 1 – INVENx Output Waveform x Invert Enable

INVENx bit selects inversion of the output or capture trigger input of channel x.

Value	Description
0	Disable inversion of the WO[x] output and IO input pin.
1	Enable inversion of the WO[x] output and IO input pin.

### 44.7.11 Debug Control

**Name:** DBGCTRL  
**Offset:** 0x0F  
**Reset:** 0x00  
**Property:** PAC Write-Protection



#### Bit 0 - DBGRUN Run in Debug Mode

This bit is not affected by a software Reset, and should not be changed by software while the TC is enabled.

Value	Description
0	The TC is halted when the device is halted in debug mode.
1	The TC continues normal operation when the device is halted in debug mode.

#### 44.7.12 Synchronization Busy

**Name:** SYNCBUSY  
**Offset:** 0x10  
**Reset:** 0x00000000  
**Property:** -

Bit	31	30	29	28	27	26	25	24
Access								
Reset								
Bit	23	22	21	20	19	18	17	16
Access								
Reset								
Bit	15	14	13	12	11	10	9	8
Access								
Reset								
Bit	7	6	5	4	3	2	1	0
Access	R	R	R	R	R	R	R	R
Reset	0	0	0	0	0	0	0	0
	CC1	CC0	PER	COUNT	STATUS	CTRLB	ENABLE	SWRST

#### Bits 6, 7 – CCx Compare/Capture Channel x Synchronization Busy [x=0..1]

For details on CC channels number, refer to each TC feature list.

This bit is set when the synchronization of CCx between clock domains is started.

This bit is also set when the CCBUFx is written, and cleared on update condition. The bit is automatically cleared when the STATUS.CCBUFx bit is cleared.

#### Bit 5 – PER PER Synchronization Busy

This bit is cleared when the synchronization of PER between the clock domains is complete.

This bit is set when the synchronization of PER between clock domains is started.

This bit is also set when the PER is written, and cleared on update condition. The bit is automatically cleared when the STATUS.PERBUF bit is cleared.

#### Bit 4 – COUNT COUNT Synchronization Busy

This bit is cleared when the synchronization of COUNT between the clock domains is complete.

This bit is set when the synchronization of COUNT between clock domains is started.

#### Bit 3 – STATUS STATUS Synchronization Busy

This bit is cleared when the synchronization of STATUS between the clock domains is complete.

This bit is set when a '1' is written to the Capture Channel Buffer Valid status flags (STATUS.CCBUFVx) and the synchronization of STATUS between clock domains is started.

#### Bit 2 – CTRLB CTRLB Synchronization Busy

This bit is cleared when the synchronization of CTRLB between the clock domains is complete.

This bit is set when the synchronization of CTRLB between clock domains is started.

**Bit 1 - ENABLE** ENABLE Synchronization Busy

This bit is cleared when the synchronization of ENABLE bit between the clock domains is complete.  
This bit is set when the synchronization of ENABLE bit between clock domains is started.

**Bit 0 - SWRST** SWRST Synchronization Busy

This bit is cleared when the synchronization of SWRST bit between the clock domains is complete.  
This bit is set when the synchronization of SWRST bit between clock domains is started.

### 44.7.13 Counter Value, 8-bit Mode

**Name:** COUNT  
**Offset:** 0x14  
**Reset:** 0x00  
**Property:** PAC Write-Protection, Write-Synchronized

**Notes:**

1. Prior to any read access, this register must be synchronized by user by writing the according TC Command value to the Control B Set register (CTRLBSET.CMD=READSYNC).
2. This register is write-synchronized: SYNCBUSY.COUNT must be checked to ensure the COUNT register synchronization is complete.

Bit	7	6	5	4	3	2	1	0
	COUNT[7:0]							
Access	R/W	R/W	R/W	R/W	R/W	R/W	R/W	R/W
Reset	0	0	0	0	0	0	0	0

**Bits 7:0 – COUNT[7:0]** Counter Value  
 These bits contain the current counter value.

#### 44.7.14 Period Value, 8-bit Mode

**Name:** PER  
**Offset:** 0x1B  
**Reset:** 0xFF  
**Property:** Write-Synchronized



**Important:** In 8-bit Mode, PER register updates using the DMA are not possible in standby mode.

**Note:** This register is write-synchronized: SYNCBUSY.PER must be checked to ensure the PER register synchronization is complete.

Bit	7	6	5	4	3	2	1	0
	PER[7:0]							
Access	R/W	R/W	R/W	R/W	R/W	R/W	R/W	R/W
Reset	0	0	0	0	0	0	0	1

**Bits 7:0 – PER[7:0]** Period Value

These bits hold the value of the TC period count.



#### 44.7.15 Channel x Compare/Capture Value, 8-bit Mode

**Name:** CCx  
**Offset:** 0x1C + x\*0x01 [x=0..1]  
**Reset:** 0x00  
**Property:** Write-Synchronized

**Note:** This register is write-synchronized: SYNCBUSY.CCx must be checked to ensure the CCx register synchronization is complete.

Bit	7	6	5	4	3	2	1	0
	CC[7:0]							
Access	R/W	R/W	R/W	R/W	R/W	R/W	R/W	R/W
Reset	0	0	0	0	0	0	0	0

#### Bits 7:0 – CC[7:0] Channel x Compare/Capture Value

These bits contain the compare/capture value in 8-bit TC mode. In Match frequency (MFRQ) or Match PWM (MPWM) waveform operation (WAVE.WAVEGEN), the CC0 register is used as a period register.

#### 44.7.16 Period Buffer Value, 8-bit Mode

**Name:** PERBUF  
**Offset:** 0x2F  
**Reset:** 0xFF  
**Property:** Write-Synchronized

**Note:** This register is write-synchronized: SYNCBUSY.PER must be checked to ensure the PER register synchronization is complete.

Bit	7	6	5	4	3	2	1	0
	PERBUF[7:0]							
Access	R/W	R/W	R/W	R/W	R/W	R/W	R/W	R/W
Reset	0	0	0	0	0	0	0	1

##### Bits 7:0 – PERBUF[7:0] Period Buffer Value

These bits hold the value of the period buffer register. The value is copied to PER register on UPDATE condition.

#### 44.7.17 Channel x Compare Buffer Value, 8-bit Mode

**Name:** CCBUFx  
**Offset:** 0x30 + x\*0x01 [x=0..1]  
**Reset:** 0x00  
**Property:** Write-Synchronized

**Note:** This register is write-synchronized: SYNCBUSY.CCx must be checked to ensure the CCx register synchronization is complete.

Bit	7	6	5	4	3	2	1	0
	CCBUF[7:0]							
Access	R/W	R/W	R/W	R/W	R/W	R/W	R/W	R/W
Reset	0	0	0	0	0	0	0	0

##### Bits 7:0 – CCBUF[7:0] Channel x Compare Buffer Value

These bits hold the value of the Channel x Compare Buffer Value. When the buffer valid flag is '1' and double buffering is enabled (CTRLBCLR.LUPD=1), the data from buffer registers will be copied into the corresponding CCx register under UPDATE condition (CTRLBSET.CMD=0x3), including the software update command.

## 44.8 Register Summary - 16-bit Mode

Offset	Name	Bit Pos.	7	6	5	4	3	2	1	0
0x00	CTRLA	7:0	ONDEMAND	RUNSTDBY	PRESCSYNC[1:0]		MODE[1:0]		ENABLE	SWRST
		15:8					ALOCK	PRESCALER[2:0]		
		23:16			COPEN1	COPEN0			CAPTEN1	CAPTEN0
		31:24				CAPTMODE1[1:0]			CAPTMODE0[1:0]	
0x04	CTRLBCLR	7:0	CMD[2:0]				ONESHOT	LUPD	DIR	
0x05	CTRLBSET	7:0	CMD[2:0]				ONESHOT	LUPD	DIR	
0x06	EVCTRL	7:0			TCEI	TCINV		EVACT[2:0]		
		15:8			MCEO1	MCEO0			OVFEO	
0x08	INTENCLR	7:0			MC1	MC0		ERR	OVF	
0x09	INTENSET	7:0			MC1	MC0		ERR	OVF	
0x0A	INTFLAG	7:0			MC1	MC0		ERR	OVF	
0x0B	STATUS	7:0			CCBUFV1	CCBUFV0	PERBUFV		SLAVE	STOP
0x0C	WAVE	7:0						WAVEGEN[1:0]		
0x0D	DRVCTRL	7:0						INVEN1	INVEN0	
0x0E	Reserved									
0x0F	DBGCTRL	7:0								DBGRUN
0x10	SYNCBUSY	7:0	CC1	CC0	PER	COUNT	STATUS	CTRLB	ENABLE	SWRST
		15:8								
		23:16								
		31:24								
0x14	COUNT	7:0	COUNT[7:0]							
		15:8	COUNT[15:8]							
0x16 ... 0x1B	Reserved									
0x1C	CC0	7:0	CC[7:0]							
		15:8	CC[15:8]							
0x1E	CC1	7:0	CC[7:0]							
		15:8	CC[15:8]							
0x20 ... 0x2F	Reserved									
0x30	CCBUF0	7:0	CCBUF[7:0]							
		15:8	CCBUF[15:8]							
0x32	CCBUF1	7:0	CCBUF[7:0]							
		15:8	CCBUF[15:8]							

### 44.8.1 Control A

**Name:** CTRLA  
**Offset:** 0x00  
**Reset:** 0x00000000  
**Property:** PAC Write-Protection, Write-Synchronized Bits, Enable-Protected Bits

Bit	31	30	29	28	27	26	25	24
			CAPTMODE1[1:0]				CAPTMODE0[1:0]	
Access			R/W	R/W			R/W	R/W
Reset			0	0			0	0
Bit	23	22	21	20	19	18	17	16
			COPEN1	COPEN0			CAPTEN1	CAPTEN0
Access			R/W	R/W			R/W	R/W
Reset			0	0			0	0
Bit	15	14	13	12	11	10	9	8
					ALOCK	PRESCALER[2:0]		
Access					R/W	R/W	R/W	R/W
Reset					0	0	0	0
Bit	7	6	5	4	3	2	1	0
	ONDEMAND	RUNSTDBY	PRESCSYNC[1:0]		MODE[1:0]		ENABLE	SWRST
Access	R/W	R/W	R/W	R/W	R/W	R/W	R/W	W
Reset	0	0	0	0	0	0	0	0

#### Bits 28:27 – CAPTMODE1[1:0] Capture mode Channel 1

These bits select the channel 1 capture mode.

Value	Name	Description
0x0	DEFAULT	Default capture
0x1	CAPTMIN	Minimum capture
0x2	CAPTMAX	Maximum capture
0x3	—	Reserved

#### Bits 25:24 – CAPTMODE0[1:0] Capture mode Channel 0

These bits select the channel 0 capture mode.

Value	Name	Description
0x0	DEFAULT	Default capture
0x1	CAPTMIN	Minimum capture
0x2	CAPTMAX	Maximum capture
0x3	—	Reserved

#### Bits 20, 21 – COPENx Capture On Pin x Enable

Bit x of COPEN[1:0] selects the trigger source for capture operation, either events or I/O pin input. This bit is not synchronized.

Value	Description
0	Event from Event System is selected as trigger source for capture operation on channel x.
1	I/O pin is selected as trigger source for capture operation on channel x.

#### Bits 16, 17 – CAPTENx Capture Channel x Enable

Bit x of CAPTEN[1:0] selects whether channel x is a capture or a compare channel. These bits are not synchronized.

Value	Description
0	CAPTEN disables capture on channel x.
1	CAPTEN enables capture on channel x.

#### Bit 11 – ALOCK Auto Lock

When this bit is set, Lock bit update (LUPD) is set to '1' on each overflow/underflow or re-trigger event.

This bit is not synchronized.

Value	Description
0	The LUPD bit is not affected on overflow/underflow, and re-trigger event.
1	The LUPD bit is set on each overflow/underflow or re-trigger event.

#### Bits 10:8 – PRESCALER[2:0] Prescaler

These bits select the counter prescaler factor.

These bits are not synchronized.

Value	Name	Description
0x0	DIV1	Prescaler: GCLK_TC
0x1	DIV2	Prescaler: GCLK_TC/2
0x2	DIV4	Prescaler: GCLK_TC/4
0x3	DIV8	Prescaler: GCLK_TC/8
0x4	DIV16	Prescaler: GCLK_TC/16
0x5	DIV64	Prescaler: GCLK_TC/64
0x6	DIV256	Prescaler: GCLK_TC/256
0x7	DIV1024	Prescaler: GCLK_TC/1024

#### Bit 7 – ONDEMAND Clock On Demand

This bit selects the clock requirements when the TC is stopped.

In standby mode, if the Run in Standby bit (CTRLA.RUNSTDBY) is '0', ONDEMAND is forced to '0'.

This bit is not synchronized.

Value	Description
0	The On Demand is disabled. If On Demand is disabled, the TC will continue to request the clock when its operation is stopped (STATUS.STOP=1).
1	The On Demand is enabled. When On Demand is enabled, the stopped TC will not request the clock. The clock is requested when a software re-trigger command is applied or when an event with start/re-trigger action is detected.

#### Bit 6 – RUNSTDBY Run in Standby

This bit is used to keep the TC running in standby mode.

This bit is not synchronized.

Value	Description
0	The TC is halted in standby.
1	The TC continues to run in standby.

#### Bits 5:4 – PRESCSYNC[1:0] Prescaler and Counter Synchronization

These bits select whether the counter should wrap around on the next GCLK\_TCx clock or the next prescaled GCLK\_TCx clock. It also makes it possible to reset the prescaler.

These bits are not synchronized.

Value	Name	Description
0x0	GCLK	Reload or reset the counter on next generic clock
0x1	PRESC	Reload or reset the counter on next prescaler clock
0x2	RESYNC	Reload or reset the counter on next generic clock. Reset the prescaler counter
0x3	-	Reserved

#### Bits 3:2 – MODE[1:0] Timer Counter Mode

These bits select the counter mode.

These bits are not synchronized.

Value	Name	Description
0x0	COUNT16	Counter in 16-bit mode
0x1	COUNT8	Counter in 8-bit mode
0x2	COUNT32	Counter in 32-bit mode
0x3	-	Reserved

#### Bit 1 – ENABLE Enable

Due to synchronization, there is delay from writing CTRLA.ENABLE until the peripheral is enabled/disabled. The value written to CTRLA.ENABLE will read back immediately, and the ENABLE Synchronization Busy bit in the SYNCBUSY register (SYNCBUSY.ENABLE) will be set. SYNCBUSY.ENABLE will be cleared when the operation is complete. This bit is not enable-protected.

Value	Description
0	The peripheral is disabled.
1	The peripheral is enabled.

#### Bit 0 – SWRST Software Reset

Writing a '0' to this bit has no effect.

Writing a '1' to this bit resets all registers in the TC, except DBGCTRL, to their initial state, and the TC will be disabled.

Writing a '1' to CTRLA.SWRST will always take precedence; all other writes in the same write-operation will be discarded.

##### Notes:

1. When the CTRLA.SWRST is written, the user must poll the SYNCBUSY.SWRST bit to know when the reset operation is complete.
2. During a SWRST, access to registers/bits without the SWRST are disallowed until the SYNCBUSY.SWRST is cleared by hardware.
3. This bit is not Enable-Protected.

## 44.8.2 Control B Clear

**Name:** CTRLBCLR  
**Offset:** 0x04  
**Reset:** 0x00  
**Property:** PAC Write-Protection, Read-Synchronized, Write-Synchronized

**Note:** This register is read-synchronized and write-synchronized: SYNCBUSY.CTRLB must be checked to ensure the CTRLBCLR register synchronization is complete.

This register allows the user to clear bits in the CTRLB register without doing a read-modify-write operation. Changes in this register will also be reflected in the Control B Set register (CTRLBSET).

Bit	7	6	5	4	3	2	1	0
	CMD[2:0]					ONESHOT	LUPD	DIR
Access	R/W	R/W	R/W			R/W	R/W	R/W
Reset	0	0	0			0	0	0

### Bits 7:5 – CMD[2:0] Command

Writing a '0' to these bits has no effect.

Writing a '1' to any of these bits will clear the pending command.

### Bit 2 – ONESHOT One-Shot on Counter

This bit controls one-shot operation of the TC.

Writing a '0' to this bit has no effect

Writing a '1' to this bit will disable one-shot operation.

Value	Description
0	The TC will wrap around and continue counting on an overflow/underflow condition.
1	The TC will wrap around and stop on the next underflow/overflow condition.

### Bit 1 – LUPD Lock Update

This bit controls the update operation of the TC buffered registers.

When CTRLB.LUPD is set, no any update of the registers with value of its buffered register is performed on hardware UPDATE condition. Locking the update ensures that all buffer registers are valid before an hardware update is performed. After all the buffer registers are loaded correctly, the buffered registers can be unlocked.

This bit has no effect when input capture operation is enabled.

Writing a '0' to this bit has no effect.

Writing a '1' to this bit will clear the LUPD bit.

Value	Description
0	The CCBUFx and PERBUF buffer registers value are copied into CCx and PER registers on hardware update condition.
1	The CCBUFx and PERBUF buffer registers value are not copied into CCx and PER registers on hardware update condition.

### Bit 0 – DIR Counter Direction

This bit is used to change the direction of the counter.

Writing a '0' to this bit has no effect.

Writing a '1' to this bit will clear the bit and make the counter count up.

Value	Description
0	The timer/counter is counting up (incrementing).
1	The timer/counter is counting down (decrementing).



### 44.8.3 Control B Set

**Name:** CTRLBSET  
**Offset:** 0x05  
**Reset:** 0x00  
**Property:** PAC Write-Protection, Write-Synchronized

**Note:** This register is write-synchronized: SYNCBUSY.CTRLB must be checked to ensure the CTRLBCLR register synchronization is complete.

This register allows the user to set bits in the CTRLB register without doing a read-modify-write operation. Changes in this register will also be reflected in the Control B Clear register (CTRLBCLR).

Bit	7	6	5	4	3	2	1	0
	CMD[2:0]					ONESHOT	LUPD	DIR
Access	R/W	R/W	R/W			R/W	R/W	R/W
Reset	0	0	0			0	0	0

#### Bits 7:5 – CMD[2:0] Command

These bits are used for software control of the TC. The commands are executed on the next prescaled GCLK\_TCx clock cycle. When a command has been executed, the CMD bit group will be read back as zero.

Writing 0x0 to these bits has no effect.

Writing a value different from 0x0 to this bit field will issue a command for execution.



**Important:** This command requires synchronization before being executed. A valid sequence is as follows:

- Issue CMD command (CTRLBSET.CMD = command)
- Wait for CMD synchronization (SYNCBUSY.CTRLB = 0)
- Wait for CMD read back as zero (CTRLBSET.CMD = 0)

Value	Name	Description
0x0	NONE	No action
0x1	RETRIGGER	Force a start, restart or retrigger
0x2	STOP	Force a stop
0x3	UPDATE	Force update of double buffered registers
0x4	READSYNC	Force a read synchronization of COUNT

#### Bit 2 – ONESHOT One-Shot on Counter

This bit controls one-shot operation of the TC.

Writing a '0' to this bit has no effect.

Writing a '1' to this bit will enable one-shot operation.

Value	Description
0	The TC will wrap around and continue counting on an overflow/underflow condition.
1	The TC will wrap around and stop on the next underflow/overflow condition.

#### Bit 1 – LUPD Lock Update

This bit controls the update operation of the TC buffered registers.

When CTRLB.LUPD is set, no any update of the registers with value of its buffered register is performed on hardware UPDATE condition. Locking the update ensures that all buffer registers are valid before an hardware update is performed. After all the buffer registers are loaded correctly, the buffered registers can be unlocked.

Writing a '0' to this bit has no effect.

Writing a '1' to this bit will set the LUPD bit.  
 This bit has no effect when input capture operation is enabled.

Value	Description
0	The CCBUFx and PERBUF buffer registers value are copied into CCx and PER registers on hardware update condition.
1	The CCBUFx and PERBUF buffer registers value are not copied into CCx and PER registers on hardware update condition.

**Bit 0 – DIR** Counter Direction

This bit is used to change the direction of the counter.  
 Writing a '0' to this bit has no effect  
 Writing a '1' to this bit will clear the bit and make the counter count up.

Value	Description
0	The timer/counter is counting up (incrementing).
1	The timer/counter is counting down (decrementing).

#### 44.8.4 Event Control

**Name:** EVCTRL  
**Offset:** 0x06  
**Reset:** 0x0000  
**Property:** PAC Write-Protection, Enable-Protected

Bit	15	14	13	12	11	10	9	8
			MCEO1	MCEO0				OVFEO
Access			R/W	R/W				R/W
Reset			0	0				0
Bit	7	6	5	4	3	2	1	0
			TCEI	TCINV		EVACT[2:0]		
Access			R/W	R/W		R/W	R/W	R/W
Reset			0	0		0	0	0

#### Bits 12, 13 – MCEOx Match or Capture Channel x Event Output Enable [x = 1..0]

These bits enable the generation of an event for every match or capture on channel x.

Value	Description
0	Match/Capture event on channel x is disabled and will not be generated.
1	Match/Capture event on channel x is enabled and will be generated for every compare/capture.

#### Bit 8 – OVFEO Overflow/Underflow Event Output Enable

This bit enables the Overflow/Underflow event. When enabled, an event will be generated when the counter overflows/underflows.

Value	Description
0	Overflow/Underflow event is disabled and will not be generated.
1	Overflow/Underflow event is enabled and will be generated for every counter overflow/underflow.

#### Bit 5 – TCEI TC Event Enable

This bit is used to enable asynchronous input events to the TC.

Value	Description
0	Incoming events are disabled.
1	Incoming events are enabled.

#### Bit 4 – TCINV TC Inverted Event Input Polarity

This bit inverts the asynchronous input event source.

Value	Description
0	Input event source is not inverted.
1	Input event source is inverted.

#### Bits 2:0 – EVACT[2:0] Event Action

These bits define the event action the TC will perform on an event.

Value	Name	Description
0x0	OFF	Event action disabled
0x1	RETRIGGER	Start, restart or retrigger TC on event
0x2	COUNT	Count on event
0x3	START	Start TC on event
0x4	STAMP	Time stamp capture
0x5	PPW	Period captured in CC0, pulse width in CC1
0x6	PWP	Period captured in CC1, pulse width in CC0
0x7	PW	Pulse width capture

### 44.8.5 Interrupt Enable Clear

**Name:** INTENCLR  
**Offset:** 0x08  
**Reset:** 0x00  
**Property:** PAC Write-Protection

This register allows the user to disable an interrupt without doing a read-modify-write operation. Changes in this register will also be reflected in the Interrupt Enable Set register (INTENSET).

Bit	7	6	5	4	3	2	1	0
			MC1	MC0			ERR	OVF
Access			R/W	R/W			R/W	R/W
Reset			0	0			0	0

#### Bits 4, 5 – MCx Match or Capture Channel x Interrupt Enable

Writing a '0' to these bits has no effect.

Writing a '1' to MCx will clear the corresponding Match or Capture Channel x Interrupt Enable bit, which disables the Match or Capture Channel x interrupt.

Value	Description
0	The Match or Capture Channel x interrupt is disabled.
1	The Match or Capture Channel x interrupt is enabled.

#### Bit 1 – ERR Error Interrupt Disable

Writing a '0' to this bit has no effect.

Writing a '1' to this bit will clear the Error Interrupt Enable bit, which disables the Error interrupt.

Value	Description
0	The Error interrupt is disabled.
1	The Error interrupt is enabled.

#### Bit 0 – OVF Overflow Interrupt Disable

Writing a '0' to this bit has no effect.

Writing a '1' to this bit will clear the Overflow Interrupt Enable bit, which disables the Overflow interrupt request.

Value	Description
0	The Overflow interrupt is disabled.
1	The Overflow interrupt is enabled.

## 44.8.6 Interrupt Enable Set

**Name:** INTENSET  
**Offset:** 0x09  
**Reset:** 0x00  
**Property:** PAC Write-Protection

This register allows the user to enable an interrupt without doing a read-modify-write operation. Changes in this register will also be reflected in the Interrupt Enable Clear register (INTENCLR).

Bit	7	6	5	4	3	2	1	0
			MC1	MC0			ERR	OVF
Access			R/W	R/W			R/W	R/W
Reset			0	0			0	0

### Bits 4, 5 – MCx Match or Capture Channel x Interrupt Enable

Writing a '0' to these bits has no effect.

Writing a '1' to MCx will clear the corresponding Match or Capture Channel x Interrupt Enable bit, which disables the Match or Capture Channel x interrupt.

Value	Description
0	The Match or Capture Channel x interrupt is disabled.
1	The Match or Capture Channel x interrupt is enabled.

### Bit 1 – ERR Error Interrupt Enable

Writing a '0' to this bit has no effect.

Writing a '1' to this bit will set the Error Interrupt Enable bit, which enables the Error interrupt.

Value	Description
0	The Error interrupt is disabled.
1	The Error interrupt is enabled.

### Bit 0 – OVF Overflow Interrupt Enable

Writing a '0' to this bit has no effect.

Writing a '1' to this bit will set the Overflow Interrupt Enable bit, which enables the Overflow interrupt request.

Value	Description
0	The Overflow interrupt is disabled.
1	The Overflow interrupt is enabled.

### 44.8.7 Interrupt Flag Status and Clear

**Name:** INTFLAG  
**Offset:** 0x0A  
**Reset:** 0x00  
**Property:** -

Bit	7	6	5	4	3	2	1	0
			MC1	MC0			ERR	OVF
Access			R/W	R/W			R/W	R/W
Reset			0	0			0	0

#### Bits 4, 5 – MCx Match or Capture Channel x

This flag is set on a comparison match, or when the corresponding CCx register contains a valid capture value. This flag is set on the next CLK\_TC\_CNT cycle, and will generate an interrupt request if the corresponding Match or Capture Channel x Interrupt Enable bit in the Interrupt Enable Set register (INTENSET.MCx) is '1'.

Writing a '0' to one of these bits has no effect.

Writing a '1' to one of these bits will clear the corresponding Match or Capture Channel x interrupt flag

In capture operation, this flag is automatically cleared when CCx register is read.

#### Bit 1 – ERR Error Interrupt Flag

This flag is set when a new capture occurs on a channel while the corresponding Match or Capture Channel x interrupt flag is set, in which case there is nowhere to store the new capture.

Writing a '0' to this bit has no effect.

Writing a '1' to this bit clears the Error interrupt flag.

#### Bit 0 – OVF Overflow Interrupt Flag

This flag is set on the next CLK\_TC\_CNT cycle after an overflow condition occurs, and will generate an interrupt request if INTENCLR.OVF or INTENSET.OVF is '1'.

Writing a '0' to this bit has no effect.

Writing a '1' to this bit clears the Overflow interrupt flag.

## 44.8.8 Status

**Name:** STATUS  
**Offset:** 0x0B  
**Reset:** 0x01  
**Property:** Read-Synchronized, Write-Synchronized

**Note:** This register is read-synchronized and write-synchronized: SYNCBUSY.STATUS must be checked to ensure the STATUS register synchronization is complete.

Bit	7	6	5	4	3	2	1	0
			CCBUFV1	CCBUFV0	PERBUFV		SLAVE	STOP
Access			R/W	R/W	R/W		R	R
Reset			0	0	0		0	1

### Bits 4, 5 – CCBUFVx Channel x Compare or Capture Buffer Valid

For a compare channel x, the bit x is set when a new value is written to the corresponding CCBUFx register.

The bit x is cleared by writing a '1' to it when CTRLB.LUPD is set, or it is cleared automatically by hardware on UPDATE condition.

**Note:** If clearing this bit manually to force an update of the CCx register, it is necessary to clear the bit two times successively.

For a capture channel x, the bit x is set when a valid capture value is stored in the CCBUFx register. The bit x is cleared automatically when the CCx register is read.

### Bit 3 – PERBUFV Period Buffer Valid

This bit is set when a new value is written to the PERBUF register. The bit is cleared by writing '1' to the corresponding location when CTRLB.LUPD is set, or automatically cleared by hardware on UPDATE condition. This bit is available only in 8-bit mode and will always read zero in 16- and 32-bit modes.

**Note:** If clearing this bit manually to force an update of the PER register, it is necessary to clear the bit two times successively.

### Bit 1 – SLAVE Client Status Flag

This bit is only available in 32-bit mode on the Client TC (i.e., TC1 and/or TC3). The bit is set when the associated Host TC (TC0 and TC2, respectively) is set to run in 32-bit mode.

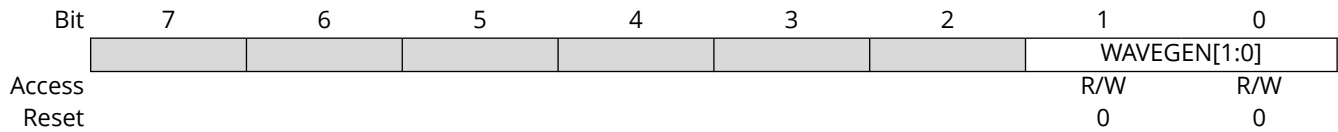
### Bit 0 – STOP Stop Status Flag

This bit is set when the TC is disabled, on a Stop command, or on an overflow/underflow condition when the One-Shot bit in the Control B Set register (CTRLBSET.ONESHOT) is '1'.

Value	Description
0	Counter is running.
1	Counter is stopped.

### 44.8.9 Waveform Generation Control

**Name:** WAVE  
**Offset:** 0x0C  
**Reset:** 0x00  
**Property:** PAC Write-Protection, Enable-Protected



#### Bits 1:0 – WAVEGEN[1:0] Waveform Generation Mode

These bits select the waveform generation operation. They affect the top value, as shown in [44.6.2.6.1. Waveform Output Operations](#). They also control whether frequency or PWM waveform generation should be used. The waveform generation operations are explained in [44.6.2.6.1. Waveform Output Operations](#).

These bits are not synchronized.

Value	Name	Operation	Top Value	Output Waveform on Match	Output Waveform on Wraparound
0x0	NFRQ	Normal frequency	PER <sup>1</sup> / Max	Toggle	No action
0x1	MFRQ	Match frequency	CC0	Toggle	No action
0x2	NPWM	Normal PWM	PER <sup>1</sup> / Max	Set	Clear
0x3	MPWM	Match PWM	CC0	Set	Clear

1) This depends on the TC mode: In 8-bit mode, the top value is the Period Value register (PER). In 16- and 32-bit mode it is the respective MAX value.



#### 44.8.10 Driver Control

**Name:** DRVCTRL  
**Offset:** 0x0D  
**Reset:** 0x00  
**Property:** PAC Write-Protection, Enable-Protected

Bit	7	6	5	4	3	2	1	0
							INVEN1	INVEN0
Access							R/W	R/W
Reset							0	0

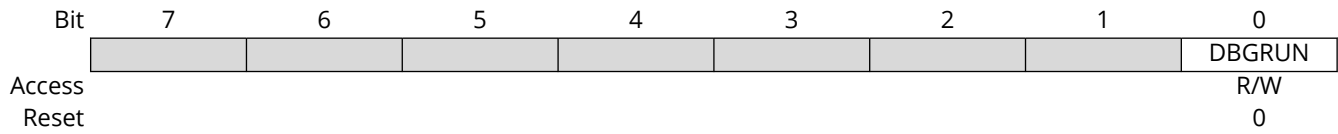
#### Bits 0, 1 – INVENx Output Waveform x Invert Enable

INVENx bit selects inversion of the output or capture trigger input of channel x.

Value	Description
0	Disable inversion of the WO[x] output and IO input pin.
1	Enable inversion of the WO[x] output and IO input pin.

### 44.8.11 Debug Control

**Name:** DBGCTRL  
**Offset:** 0x0F  
**Reset:** 0x00  
**Property:** PAC Write-Protection



#### Bit 0 - DBGRUN Run in Debug Mode

This bit is not affected by a software Reset, and should not be changed by software while the TC is enabled.

Value	Description
0	The TC is halted when the device is halted in debug mode.
1	The TC continues normal operation when the device is halted in debug mode.

#### 44.8.12 Synchronization Busy

**Name:** SYNCBUSY  
**Offset:** 0x10  
**Reset:** 0x00000000  
**Property:** -

Bit	31	30	29	28	27	26	25	24
Access								
Reset								
Bit	23	22	21	20	19	18	17	16
Access								
Reset								
Bit	15	14	13	12	11	10	9	8
Access								
Reset								
Bit	7	6	5	4	3	2	1	0
Access	R	R	R	R	R	R	R	R
Reset	0	0	0	0	0	0	0	0
	CC1	CC0	PER	COUNT	STATUS	CTRLB	ENABLE	SWRST

#### Bits 6, 7 – CCx Compare/Capture Channel x Synchronization Busy [x=0..1]

For details on CC channels number, refer to each TC feature list.

This bit is set when the synchronization of CCx between clock domains is started.

This bit is also set when the CCBUFx is written, and cleared on update condition. The bit is automatically cleared when the STATUS.CCBUFx bit is cleared.

#### Bit 5 – PER PER Synchronization Busy

This bit is cleared when the synchronization of PER between the clock domains is complete.

This bit is set when the synchronization of PER between clock domains is started.

This bit is also set when the PER is written, and cleared on update condition. The bit is automatically cleared when the STATUS.PERBUF bit is cleared.

#### Bit 4 – COUNT COUNT Synchronization Busy

This bit is cleared when the synchronization of COUNT between the clock domains is complete.

This bit is set when the synchronization of COUNT between clock domains is started.

#### Bit 3 – STATUS STATUS Synchronization Busy

This bit is cleared when the synchronization of STATUS between the clock domains is complete.

This bit is set when a '1' is written to the Capture Channel Buffer Valid status flags (STATUS.CCBUFVx) and the synchronization of STATUS between clock domains is started.

#### Bit 2 – CTRLB CTRLB Synchronization Busy

This bit is cleared when the synchronization of CTRLB between the clock domains is complete.

This bit is set when the synchronization of CTRLB between clock domains is started.

**Bit 1 - ENABLE** ENABLE Synchronization Busy

This bit is cleared when the synchronization of ENABLE bit between the clock domains is complete.  
This bit is set when the synchronization of ENABLE bit between clock domains is started.

**Bit 0 - SWRST** SWRST Synchronization Busy

This bit is cleared when the synchronization of SWRST bit between the clock domains is complete.  
This bit is set when the synchronization of SWRST bit between clock domains is started.

### 44.8.13 Counter Value, 16-bit Mode

**Name:** COUNT  
**Offset:** 0x14  
**Reset:** 0x00  
**Property:** PAC Write-Protection, Write-Synchronized

**Notes:**

1. Prior to any read access, this register must be synchronized by user by writing the according TC Command value to the Control B Set register (CTRLBSET.CMD=READSYNC).
2. This register is write-synchronized: SYNCBUSY.COUNT must be checked to ensure the COUNT register synchronization is complete.

Bit	15	14	13	12	11	10	9	8
	COUNT[15:8]							
Access	R/W	R/W	R/W	R/W	R/W	R/W	R/W	R/W
Reset	0	0	0	0	0	0	0	0
Bit	7	6	5	4	3	2	1	0
	COUNT[7:0]							
Access	R/W	R/W	R/W	R/W	R/W	R/W	R/W	R/W
Reset	0	0	0	0	0	0	0	0

**Bits 15:0 – COUNT[15:0]** Counter Value  
 These bits contain the current counter value.

#### 44.8.14 Channel x Compare/Capture Value, 16-bit Mode

**Name:** CCx  
**Offset:** 0x1C + x\*0x02 [x=0..1]  
**Reset:** 0x0000  
**Property:** Write-Synchronized

**Note:** This register is write-synchronized: SYNCBUSY.CCx must be checked to ensure the CCx register synchronization is complete.

Bit	15	14	13	12	11	10	9	8
	CC[15:8]							
Access	R/W	R/W	R/W	R/W	R/W	R/W	R/W	R/W
Reset	0	0	0	0	0	0	0	0
Bit	7	6	5	4	3	2	1	0
	CC[7:0]							
Access	R/W	R/W	R/W	R/W	R/W	R/W	R/W	R/W
Reset	0	0	0	0	0	0	0	0

#### Bits 15:0 – CC[15:0] Channel x Compare/Capture Value

These bits contain the compare/capture value in 16-bit TC mode. In Match frequency (MFRQ) or Match PWM (MPWM) waveform operation (WAVE.WAVEGEN), the CC0 register is used as a period register.

#### 44.8.15 Channel x Compare Buffer Value, 16-bit Mode

**Name:** CCBUFx  
**Offset:** 0x30 + x\*0x02 [x=0..1]  
**Reset:** 0x0000  
**Property:** Write-Synchronized

**Note:** This register is write-synchronized: SYNCBUSY.CCx must be checked to ensure the CCx register synchronization is complete.

Bit	15	14	13	12	11	10	9	8
	CCBUF[15:8]							
Access	R/W	R/W	R/W	R/W	R/W	R/W	R/W	R/W
Reset	0	0	0	0	0	0	0	0
Bit	7	6	5	4	3	2	1	0
	CCBUF[7:0]							
Access	R/W	R/W	R/W	R/W	R/W	R/W	R/W	R/W
Reset	0	0	0	0	0	0	0	0

#### Bits 15:0 – CCBUF[15:0] Channel x Compare Buffer Value

These bits hold the value of the Channel x Compare Buffer Value. When the buffer valid flag is '1' and double buffering is enabled (CTRLBCLR.LUPD=1), the data from buffer registers will be copied into the corresponding CCx register under UPDATE condition (CTRLBSET.CMD=0x3), including the software update command.

## 44.9 Register Summary - 32-bit Mode

Offset	Name	Bit Pos.	7	6	5	4	3	2	1	0	
0x00	CTRLA	7:0	ONDEMAND	RUNSTDBY	PRESCSYNC[1:0]		MODE[1:0]		ENABLE	SWRST	
		15:8					ALOCK	PRESCALER[2:0]			
		23:16			COPEN1	COPEN0			CAPTEN1	CAPTEN0	
		31:24				CAPTMODE1[1:0]			CAPTMODE0[1:0]		
0x04	CTRLBCLR	7:0	CMD[2:0]				ONESHOT	LUPD	DIR		
0x05	CTRLBSET	7:0	CMD[2:0]				ONESHOT	LUPD	DIR		
0x06	EVCTRL	7:0			TCEI	TCINV		EVACT[2:0]			
		15:8			MCEO1	MCEO0			OVFEO		
0x08	INTENCLR	7:0			MC1	MC0		ERR	OVF		
0x09	INTENSET	7:0			MC1	MC0		ERR	OVF		
0x0A	INTFLAG	7:0			MC1	MC0		ERR	OVF		
0x0B	STATUS	7:0			CCBUFV1	CCBUFV0	PERBUFV		SLAVE	STOP	
0x0C	WAVE	7:0						WAVEGEN[1:0]			
0x0D	DRVCTRL	7:0						INVEN1	INVEN0		
0x0E	Reserved										
0x0F	DBGCTRL	7:0								DBGRUN	
0x10	SYNCBUSY	7:0	CC1	CC0	PER	COUNT	STATUS	CTRLB	ENABLE	SWRST	
		15:8									
		23:16									
		31:24									
0x14	COUNT	7:0	COUNT[7:0]								
		15:8	COUNT[15:8]								
		23:16	COUNT[23:16]								
		31:24	COUNT[31:24]								
0x18 ... 0x1B	Reserved										
0x1C	CC0	7:0	CC[7:0]								
		15:8	CC[15:8]								
		23:16	CC[23:16]								
		31:24	CC[31:24]								
0x20	CC1	7:0	CC[7:0]								
		15:8	CC[15:8]								
		23:16	CC[23:16]								
		31:24	CC[31:24]								
0x24 ... 0x2F	Reserved										
0x30	CCBUF0	7:0	CCBUF[7:0]								
		15:8	CCBUF[15:8]								
		23:16	CCBUF[23:16]								
		31:24	CCBUF[31:24]								
0x34	CCBUF1	7:0	CCBUF[7:0]								
		15:8	CCBUF[15:8]								
		23:16	CCBUF[23:16]								
		31:24	CCBUF[31:24]								



### 44.9.1 Control A

**Name:** CTRLA  
**Offset:** 0x00  
**Reset:** 0x00000000  
**Property:** PAC Write-Protection, Write-Synchronized Bits, Enable-Protected Bits

Bit	31	30	29	28	27	26	25	24
			CAPTMODE1[1:0]				CAPTMODE0[1:0]	
Access			R/W	R/W			R/W	R/W
Reset			0	0			0	0
Bit	23	22	21	20	19	18	17	16
			COPEN1	COPEN0			CAPTEN1	CAPTEN0
Access			R/W	R/W			R/W	R/W
Reset			0	0			0	0
Bit	15	14	13	12	11	10	9	8
					ALOCK	PRESCALER[2:0]		
Access					R/W	R/W	R/W	R/W
Reset					0	0	0	0
Bit	7	6	5	4	3	2	1	0
	ONDEMAND	RUNSTDBY	PRESCSYNC[1:0]		MODE[1:0]		ENABLE	SWRST
Access	R/W	R/W	R/W	R/W	R/W	R/W	R/W	W
Reset	0	0	0	0	0	0	0	0

#### Bits 28:27 – CAPTMODE1[1:0] Capture mode Channel 1

These bits select the channel 1 capture mode.

Value	Name	Description
0x0	DEFAULT	Default capture
0x1	CAPTMIN	Minimum capture
0x2	CAPTMAX	Maximum capture
0x3	—	Reserved

#### Bits 25:24 – CAPTMODE0[1:0] Capture mode Channel 0

These bits select the channel 0 capture mode.

Value	Name	Description
0x0	DEFAULT	Default capture
0x1	CAPTMIN	Minimum capture
0x2	CAPTMAX	Maximum capture
0x3	—	Reserved

#### Bits 20, 21 – COPENx Capture On Pin x Enable

The bit x of COPEN[1:0] selects the trigger source for capture operation, either events or I/O pin input.

This bit is not synchronized.

Value	Description
0	Event from Event System is selected as trigger source for capture operation on channel x.
1	I/O pin is selected as trigger source for capture operation on channel x.

#### Bits 16, 17 – CAPTENx Capture Channel x Enable

The bit x of CAPTEN[1:0] selects whether channel x is a capture or a compare channel.

These bits are not synchronized.

Value	Description
0	CAPTEN disables capture on channel x.
1	CAPTEN enables capture on channel x.

#### Bit 11 – ALOCK Auto Lock

When this bit is set, Lock bit update (LUPD) is set to '1' on each overflow/underflow or re-trigger event.

This bit is not synchronized.

Value	Description
0	The LUPD bit is not affected on overflow/underflow, and re-trigger event.
1	The LUPD bit is set on each overflow/underflow or re-trigger event.

#### Bits 10:8 – PRESCALER[2:0] Prescaler

These bits select the counter prescaler factor.

These bits are not synchronized.

Value	Name	Description
0x0	DIV1	Prescaler: GCLK_TC
0x1	DIV2	Prescaler: GCLK_TC/2
0x2	DIV4	Prescaler: GCLK_TC/4
0x3	DIV8	Prescaler: GCLK_TC/8
0x4	DIV16	Prescaler: GCLK_TC/16
0x5	DIV64	Prescaler: GCLK_TC/64
0x6	DIV256	Prescaler: GCLK_TC/256
0x7	DIV1024	Prescaler: GCLK_TC/1024

#### Bit 7 – ONDEMAND Clock On Demand

This bit selects the clock requirements when the TC is stopped.

In Standby mode, if the Run in Standby bit (CTRLA.RUNSTDBY) is '0', ONDEMAND is forced to '0'.

This bit is not synchronized.

Value	Description
0	The On Demand is disabled. If On Demand is disabled, the TC will continue to request the clock when its operation is stopped (STATUS.STOP = 1).
1	The On Demand is enabled. When On Demand is enabled, the stopped TC will not request the clock. The clock is requested when a software re-trigger command is applied or when an event with start/re-trigger action is detected.

#### Bit 6 – RUNSTDBY Run in Standby

This bit is used to keep the TC running in Standby mode.

This bit is not synchronized.

Value	Description
0	The TC is halted in standby.
1	The TC continues to run in standby.

#### Bits 5:4 – PRESCSYNC[1:0] Prescaler and Counter Synchronization

These bits select whether the counter should wrap around on the next GCLK\_TCx clock or the next prescaled GCLK\_TCx clock. It also makes it possible to reset the prescaler.

These bits are not synchronized.

Value	Name	Description
0x0	GCLK	Reload or reset the counter on next generic clock
0x1	PRESC	Reload or reset the counter on next prescaler clock
0x2	RESYNC	Reload or reset the counter on next generic clock. Reset the prescaler counter
0x3	-	Reserved

#### Bits 3:2 – MODE[1:0] Timer Counter Mode

These bits select the counter mode.

These bits are not synchronized.

Value	Name	Description
0x0	COUNT16	Counter in 16-bit mode
0x1	COUNT8	Counter in 8-bit mode
0x2	COUNT32	Counter in 32-bit mode
0x3	-	Reserved

**Bit 1 – ENABLE** Enable

Due to synchronization, there is delay from writing CTRLA.ENABLE until the peripheral is enabled or disabled. The value written to CTRLA.ENABLE will read back immediately, and the ENABLE Synchronization Busy bit in the SYNCBUSY register (SYNCBUSY.ENABLE) will be set. The SYNCBUSY.ENABLE register will be cleared when the operation is complete. This bit is not enable-protected.

Value	Description
0	The peripheral is disabled.
1	The peripheral is enabled.

**Bit 0 – SWRST** Software Reset

Writing a '0' to this bit has no effect.

Writing a '1' to this bit resets all registers in the TC, except DBGCTRL, to their initial state, and the TC will be disabled.

Writing a '1' to CTRLA.SWRST will always take precedence; all other writes in the same write-operation will be discarded.

**Notes:**

1. When the CTRLA.SWRST is written, the user must poll the SYNCBUSY.SWRST bit to know when the reset operation is complete.
2. During a SWRST, access to registers or bits without the SWRST are disallowed until the SYNCBUSY.SWRST is cleared by hardware.
3. This bit is not Enable-Protected.

## 44.9.2 Control B Clear

**Name:** CTRLBCLR  
**Offset:** 0x04  
**Reset:** 0x00  
**Property:** PAC Write-Protection, Read-Synchronized, Write-Synchronized

**Note:** This register is read-synchronized and write-synchronized: SYNCBUSY.CTRLB must be checked to ensure the CTRLBCLR register synchronization is complete.

This register allows the user to clear bits in the CTRLB register without doing a read-modify-write operation. Changes in this register will also be reflected in the Control B Set register (CTRLBSET).

Bit	7	6	5	4	3	2	1	0
	CMD[2:0]					ONESHOT	LUPD	DIR
Access	R/W	R/W	R/W			R/W	R/W	R/W
Reset	0	0	0			0	0	0

### Bits 7:5 – CMD[2:0] Command

Writing a '0' to these bits has no effect.

Writing a '1' to any of these bits will clear the pending command.

### Bit 2 – ONESHOT One-Shot on Counter

This bit controls one-shot operation of the TC.

Writing a '0' to this bit has no effect

Writing a '1' to this bit will disable one-shot operation.

Value	Description
0	The TC will wrap around and continue counting on an overflow/underflow condition.
1	The TC will wrap around and stop on the next underflow/overflow condition.

### Bit 1 – LUPD Lock Update

This bit controls the update operation of the TC buffered registers.

When CTRLB.LUPD is set, no any update of the registers with value of its buffered register is performed on hardware UPDATE condition. Locking the update ensures that all buffer registers are valid before an hardware update is performed. After all the buffer registers are loaded correctly, the buffered registers can be unlocked.

This bit has no effect when input capture operation is enabled.

Writing a '0' to this bit has no effect.

Writing a '1' to this bit will clear the LUPD bit.

Value	Description
0	The CCBUFx and PERBUF buffer registers value are copied into CCx and PER registers on hardware update condition.
1	The CCBUFx and PERBUF buffer registers value are not copied into CCx and PER registers on hardware update condition.

### Bit 0 – DIR Counter Direction

This bit is used to change the direction of the counter.

Writing a '0' to this bit has no effect.

Writing a '1' to this bit will clear the bit and make the counter count up.

Value	Description
0	The timer/counter is counting up (incrementing).
1	The timer/counter is counting down (decrementing).

### 44.9.3 Control B Set

**Name:** CTRLBSET  
**Offset:** 0x05  
**Reset:** 0x00  
**Property:** PAC Write-Protection, Write-Synchronized

**Note:** This register is write-synchronized: SYNCBUSY.CTRLB must be checked to ensure the CTRLBCLR register synchronization is complete.

This register allows the user to set bits in the CTRLB register without doing a read-modify-write operation. Changes in this register will also be reflected in the Control B Clear register (CTRLBCLR).

Bit	7	6	5	4	3	2	1	0
	CMD[2:0]					ONESHOT	LUPD	DIR
Access	R/W	R/W	R/W			R/W	R/W	R/W
Reset	0	0	0			0	0	0

#### Bits 7:5 – CMD[2:0] Command

These bits are used for software control of the TC. The commands are executed on the next prescaled GCLK\_TCx clock cycle. When a command has been executed, the CMD bit group will be read back as zero.

Writing 0x0 to these bits has no effect.

Writing a value different from 0x0 to this bit field will issue a command for execution.



**Important:** This command requires synchronization before being executed. A valid sequence is the following:

- Issue CMD command (CTRLBSET.CMD = command)
- Wait for CMD synchronization (SYNCBUSY.CTRLB = 0)
- Wait for CMD read back as zero (CTRLBSET.CMD = 0)

Value	Name	Description
0x0	NONE	No action
0x1	RETRIGGER	Force a start, restart or retrigger
0x2	STOP	Force a stop
0x3	UPDATE	Force update of double buffered registers
0x4	READSYNC	Force a read synchronization of COUNT

#### Bit 2 – ONESHOT One-Shot on Counter

This bit controls one-shot operation of the TC.

Writing a '0' to this bit has no effect.

Writing a '1' to this bit will enable one-shot operation.

Value	Description
0	The TC will wrap around and continue counting on an overflow/underflow condition.
1	The TC will wrap around and stop on the next underflow/overflow condition.

#### Bit 1 – LUPD Lock Update

This bit controls the update operation of the TC buffered registers.

When CTRLB.LUPD is set, no any update of the registers with value of its buffered register is

performed on hardware UPDATE condition. Locking the update ensures that all buffer registers are valid before an hardware update is performed. After all the buffer registers are loaded correctly, the buffered registers can be unlocked.

Writing a '0' to this bit has no effect.

Writing a '1' to this bit will set the LUPD bit.  
 This bit has no effect when input capture operation is enabled.

Value	Description
0	The CCBUFx and PERBUF buffer registers value are copied into CCx and PER registers on hardware update condition.
1	The CCBUFx and PERBUF buffer registers value are not copied into CCx and PER registers on hardware update condition.

**Bit 0 – DIR** Counter Direction

This bit is used to change the direction of the counter.  
 Writing a '0' to this bit has no effect  
 Writing a '1' to this bit will clear the bit and make the counter count up.

Value	Description
0	The timer/counter is counting up (incrementing).
1	The timer/counter is counting down (decrementing).

#### 44.9.4 Event Control

**Name:** EVCTRL  
**Offset:** 0x06  
**Reset:** 0x0000  
**Property:** PAC Write-Protection, Enable-Protected

Bit	15	14	13	12	11	10	9	8
			MCEO1	MCEO0				OVFEO
Access			R/W	R/W				R/W
Reset			0	0				0
Bit	7	6	5	4	3	2	1	0
			TCEI	TCINV		EVACT[2:0]		
Access			R/W	R/W		R/W	R/W	R/W
Reset			0	0		0	0	0

#### Bits 12, 13 – MCEOx Match or Capture Channel x Event Output Enable [x = 1..0]

These bits enable the generation of an event for every match or capture on channel x.

Value	Description
0	Match/Capture event on channel x is disabled and will not be generated.
1	Match/Capture event on channel x is enabled and will be generated for every compare/capture.

#### Bit 8 – OVFEO Overflow/Underflow Event Output Enable

This bit enables the Overflow/Underflow event. When enabled, an event will be generated when the counter overflows/underflows.

Value	Description
0	Overflow/Underflow event is disabled and will not be generated.
1	Overflow/Underflow event is enabled and will be generated for every counter overflow/underflow.

#### Bit 5 – TCEI TC Event Enable

This bit is used to enable asynchronous input events to the TC.

Value	Description
0	Incoming events are disabled.
1	Incoming events are enabled.

#### Bit 4 – TCINV TC Inverted Event Input Polarity

This bit inverts the asynchronous input event source.

Value	Description
0	Input event source is not inverted.
1	Input event source is inverted.

#### Bits 2:0 – EVACT[2:0] Event Action

These bits define the event action the TC will perform on an event.

Value	Name	Description
0x0	OFF	Event action disabled
0x1	RETRIGGER	Start, restart or retrigger TC on event
0x2	COUNT	Count on event
0x3	START	Start TC on event
0x4	STAMP	Time stamp capture
0x5	PPW	Period captured in CC0, pulse width in CC1
0x6	PWP	Period captured in CC1, pulse width in CC0
0x7	PW	Pulse width capture

### 44.9.5 Interrupt Enable Clear

**Name:** INTENCLR  
**Offset:** 0x08  
**Reset:** 0x00  
**Property:** PAC Write-Protection

This register allows the user to disable an interrupt without doing a read-modify-write operation. Changes in this register will also be reflected in the Interrupt Enable Set register (INTENSET).

Bit	7	6	5	4	3	2	1	0
			MC1	MC0			ERR	OVF
Access			R/W	R/W			R/W	R/W
Reset			0	0			0	0

#### Bits 4, 5 – MCx Match or Capture Channel x Interrupt Enable

Writing a '0' to these bits has no effect.

Writing a '1' to MCx will clear the corresponding Match or Capture Channel x Interrupt Enable bit, which disables the Match or Capture Channel x interrupt.

Value	Description
0	The Match or Capture Channel x interrupt is disabled.
1	The Match or Capture Channel x interrupt is enabled.

#### Bit 1 – ERR Error Interrupt Disable

Writing a '0' to this bit has no effect.

Writing a '1' to this bit will clear the Error Interrupt Enable bit, which disables the Error interrupt.

Value	Description
0	The Error interrupt is disabled.
1	The Error interrupt is enabled.

#### Bit 0 – OVF Overflow Interrupt Disable

Writing a '0' to this bit has no effect.

Writing a '1' to this bit will clear the Overflow Interrupt Enable bit, which disables the Overflow interrupt request.

Value	Description
0	The Overflow interrupt is disabled.
1	The Overflow interrupt is enabled.



## 44.9.6 Interrupt Enable Set

**Name:** INTENSET  
**Offset:** 0x09  
**Reset:** 0x00  
**Property:** PAC Write-Protection

This register allows the user to enable an interrupt without doing a read-modify-write operation. Changes in this register will also be reflected in the Interrupt Enable Clear register (INTENCLR).

Bit	7	6	5	4	3	2	1	0
			MC1	MC0			ERR	OVF
Access			R/W	R/W			R/W	R/W
Reset			0	0			0	0

### Bits 4, 5 – MCx Match or Capture Channel x Interrupt Enable

Writing a '0' to these bits has no effect.

Writing a '1' to MCx will clear the corresponding Match or Capture Channel x Interrupt Enable bit, which disables the Match or Capture Channel x interrupt.

Value	Description
0	The Match or Capture Channel x interrupt is disabled.
1	The Match or Capture Channel x interrupt is enabled.

### Bit 1 – ERR Error Interrupt Enable

Writing a '0' to this bit has no effect.

Writing a '1' to this bit will set the Error Interrupt Enable bit, which enables the Error interrupt.

Value	Description
0	The Error interrupt is disabled.
1	The Error interrupt is enabled.

### Bit 0 – OVF Overflow Interrupt Enable

Writing a '0' to this bit has no effect.

Writing a '1' to this bit will set the Overflow Interrupt Enable bit, which enables the Overflow interrupt request.

Value	Description
0	The Overflow interrupt is disabled.
1	The Overflow interrupt is enabled.

### 44.9.7 Interrupt Flag Status and Clear

**Name:** INTFLAG  
**Offset:** 0x0A  
**Reset:** 0x00  
**Property:** -

Bit	7	6	5	4	3	2	1	0
			MC1	MC0			ERR	OVF
Access			R/W	R/W			R/W	R/W
Reset			0	0			0	0

#### Bits 4, 5 – MCx Match or Capture Channel x

This flag is set on a comparison match, or when the corresponding CCx register contains a valid capture value. This flag is set on the next CLK\_TC\_CNT cycle, and will generate an interrupt request if the corresponding Match or Capture Channel x Interrupt Enable bit in the Interrupt Enable Set register (INTENSET.MCx) is '1'.

Writing a '0' to one of these bits has no effect.

Writing a '1' to one of these bits will clear the corresponding Match or Capture Channel x interrupt flag

In capture operation, this flag is automatically cleared when CCx register is read.

#### Bit 1 – ERR Error Interrupt Flag

This flag is set when a new capture occurs on a channel while the corresponding Match or Capture Channel x interrupt flag is set, in which case there is nowhere to store the new capture.

Writing a '0' to this bit has no effect.

Writing a '1' to this bit clears the Error interrupt flag.

#### Bit 0 – OVF Overflow Interrupt Flag

This flag is set on the next CLK\_TC\_CNT cycle after an overflow condition occurs, and will generate an interrupt request if INTENCLR.OVF or INTENSET.OVF is '1'.

Writing a '0' to this bit has no effect.

Writing a '1' to this bit clears the Overflow interrupt flag.

## 44.9.8 Status

**Name:** STATUS  
**Offset:** 0x0B  
**Reset:** 0x01  
**Property:** Read-Synchronized, Write-Synchronized

**Note:** This register is read-synchronized and write-synchronized: SYNCBUSY.STATUS must be checked to ensure the STATUS register synchronization is complete.

Bit	7	6	5	4	3	2	1	0
			CCBUFV1	CCBUFV0	PERBUFV		SLAVE	STOP
Access			R/W	R/W	R/W		R	R
Reset			0	0	0		0	1

### Bits 4, 5 – CCBUFVx Channel x Compare or Capture Buffer Valid

For a compare channel x, the bit x is set when a new value is written to the corresponding CCBUFx register.

The bit x is cleared by writing a '1' to it when CTRLB.LUPD is set, or it is cleared automatically by hardware on UPDATE condition.

**Note:** If clearing this bit manually to force an update of the CCx register, it is necessary to clear the bit two times successively.

For a capture channel x, the bit x is set when a valid capture value is stored in the CCBUFx register. The bit x is cleared automatically when the CCx register is read.

### Bit 3 – PERBUFV Period Buffer Valid

This bit is set when a new value is written to the PERBUF register. The bit is cleared by writing '1' to the corresponding location when CTRLB.LUPD is set, or automatically cleared by hardware on UPDATE condition. This bit is available only in 8-bit mode and will always read zero in 16-bit and 32-bit modes.

**Note:** If clearing this bit manually to force an update of the PER register, it is necessary to clear the bit two times successively.

### Bit 1 – SLAVE Client Status Flag

This bit is only available in 32-bit mode on the Client TC (i.e., TC1 and/or TC3). The bit is set when the associated Host TC (TC0 and TC2, respectively) is set to run in 32-bit mode.

### Bit 0 – STOP Stop Status Flag

This bit is set when the TC is disabled, on a Stop command, or on an overflow/underflow condition when the One-Shot bit in the Control B Set register (CTRLBSET.ONESHOT) is '1'.

Value	Description
0	Counter is running.
1	Counter is stopped.

### 44.9.9 Waveform Generation Control

**Name:** WAVE  
**Offset:** 0x0C  
**Reset:** 0x00  
**Property:** PAC Write-Protection, Enable-Protected

Bit	7	6	5	4	3	2	1	0
							WAVEGEN[1:0]	
Access							R/W	R/W
Reset							0	0

#### Bits 1:0 – WAVEGEN[1:0] Waveform Generation Mode

These bits select the waveform generation operation. They affect the top value, as shown in [44.6.2.6.1. Waveform Output Operations](#). They also control whether frequency or PWM waveform generation should be used. The waveform generation operations are explained in [44.6.2.6.1. Waveform Output Operations](#).

These bits are not synchronized.

Value	Name	Operation	Top Value	Output Waveform on Match	Output Waveform on Wraparound
0x0	NFRQ	Normal frequency	PER <sup>1</sup> / Max	Toggle	No action
0x1	MFRQ	Match frequency	CC0	Toggle	No action
0x2	NPWM	Normal PWM	PER <sup>1</sup> / Max	Set	Clear
0x3	MPWM	Match PWM	CC0	Set	Clear

1) This depends on the TC mode: In 8-bit mode, the top value is the Period Value register (PER). In 16- and 32-bit mode it is the respective MAX value.

#### 44.9.10 Driver Control

**Name:** DRVCTRL  
**Offset:** 0x0D  
**Reset:** 0x00  
**Property:** PAC Write-Protection, Enable-Protected

Bit	7	6	5	4	3	2	1	0
							INVEN1	INVEN0
Access							R/W	R/W
Reset							0	0

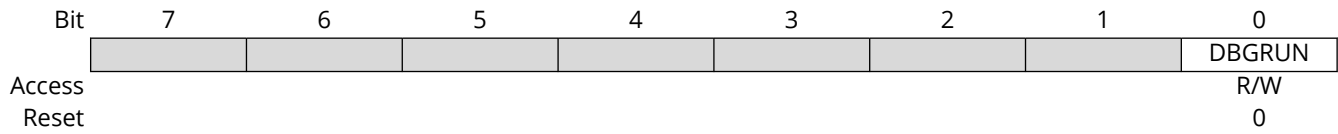
#### Bits 0, 1 – INVENx Output Waveform x Invert Enable

INVENx bit selects inversion of the output or capture trigger input of channel x.

Value	Description
0	Disable inversion of the WO[x] output and IO input pin.
1	Enable inversion of the WO[x] output and IO input pin.

#### 44.9.11 Debug Control

**Name:** DBGCTRL  
**Offset:** 0x0F  
**Reset:** 0x00  
**Property:** PAC Write-Protection



##### Bit 0 - DBGRUN Run in Debug Mode

This bit is not affected by a software Reset, and should not be changed by software while the TC is enabled.

Value	Description
0	The TC is halted when the device is halted in debug mode.
1	The TC continues normal operation when the device is halted in debug mode.

#### 44.9.12 Synchronization Busy

**Name:** SYNCBUSY  
**Offset:** 0x10  
**Reset:** 0x00000000  
**Property:** -

Bit	31	30	29	28	27	26	25	24
Access								
Reset								
Bit	23	22	21	20	19	18	17	16
Access								
Reset								
Bit	15	14	13	12	11	10	9	8
Access								
Reset								
Bit	7	6	5	4	3	2	1	0
Access	R	R	R	R	R	R	R	R
Reset	0	0	0	0	0	0	0	0
	CC1	CC0	PER	COUNT	STATUS	CTRLB	ENABLE	SWRST

#### Bits 6, 7 – CCx Compare/Capture Channel x Synchronization Busy [x=0..1]

For details on CC channels number, refer to each TC feature list.

This bit is set when the synchronization of CCx between clock domains is started.

This bit is also set when the CCBUFx is written, and cleared on update condition. The bit is automatically cleared when the STATUS.CCBUFx bit is cleared.

#### Bit 5 – PER PER Synchronization Busy

This bit is cleared when the synchronization of PER between the clock domains is complete.

This bit is set when the synchronization of PER between clock domains is started.

This bit is also set when the PER is written, and cleared on update condition. The bit is automatically cleared when the STATUS.PERBUF bit is cleared.

#### Bit 4 – COUNT COUNT Synchronization Busy

This bit is cleared when the synchronization of COUNT between the clock domains is complete.

This bit is set when the synchronization of COUNT between clock domains is started.

#### Bit 3 – STATUS STATUS Synchronization Busy

This bit is cleared when the synchronization of STATUS between the clock domains is complete.

This bit is set when a '1' is written to the Capture Channel Buffer Valid status flags (STATUS.CCBUFVx) and the synchronization of STATUS between clock domains is started.

#### Bit 2 – CTRLB CTRLB Synchronization Busy

This bit is cleared when the synchronization of CTRLB between the clock domains is complete.

This bit is set when the synchronization of CTRLB between clock domains is started.

**Bit 1 - ENABLE** ENABLE Synchronization Busy

This bit is cleared when the synchronization of ENABLE bit between the clock domains is complete.  
This bit is set when the synchronization of ENABLE bit between clock domains is started.

**Bit 0 - SWRST** SWRST Synchronization Busy

This bit is cleared when the synchronization of SWRST bit between the clock domains is complete.  
This bit is set when the synchronization of SWRST bit between clock domains is started.



### 44.9.13 Counter Value, 32-bit Mode

**Name:** COUNT  
**Offset:** 0x14  
**Reset:** 0x00  
**Property:** PAC Write-Protection, Write-Synchronized

**Notes:**

1. Prior to any read access, this register must be synchronized by user by writing the according TC Command value to the Control B Set register (CTRLBSET.CMD=READSYNC).
2. This register is write-synchronized: SYNCBUSY.COUNT must be checked to ensure the COUNT register synchronization is complete.

Bit	31	30	29	28	27	26	25	24
	COUNT[31:24]							
Access	R/W	R/W	R/W	R/W	R/W	R/W	R/W	R/W
Reset	0	0	0	0	0	0	0	0
Bit	23	22	21	20	19	18	17	16
	COUNT[23:16]							
Access	R/W	R/W	R/W	R/W	R/W	R/W	R/W	R/W
Reset	0	0	0	0	0	0	0	0
Bit	15	14	13	12	11	10	9	8
	COUNT[15:8]							
Access	R/W	R/W	R/W	R/W	R/W	R/W	R/W	R/W
Reset	0	0	0	0	0	0	0	0
Bit	7	6	5	4	3	2	1	0
	COUNT[7:0]							
Access	R/W	R/W	R/W	R/W	R/W	R/W	R/W	R/W
Reset	0	0	0	0	0	0	0	0

**Bits 31:0 - COUNT[31:0]** Counter Value  
 These bits contain the current counter value.

#### 44.9.14 Channel x Compare/Capture Value, 32-bit Mode

**Name:** CCx  
**Offset:** 0x1C + x\*0x04 [x=0..1]  
**Reset:** 0x00000000  
**Property:** Write-Synchronized

**Note:** This register is write-synchronized: SYNCBUSY.CCx must be checked to ensure the CCx register synchronization is complete.

Bit	31	30	29	28	27	26	25	24
	CC[31:24]							
Access	R/W	R/W	R/W	R/W	R/W	R/W	R/W	R/W
Reset	0	0	0	0	0	0	0	0
Bit	23	22	21	20	19	18	17	16
	CC[23:16]							
Access	R/W	R/W	R/W	R/W	R/W	R/W	R/W	R/W
Reset	0	0	0	0	0	0	0	0
Bit	15	14	13	12	11	10	9	8
	CC[15:8]							
Access	R/W	R/W	R/W	R/W	R/W	R/W	R/W	R/W
Reset	0	0	0	0	0	0	0	0
Bit	7	6	5	4	3	2	1	0
	CC[7:0]							
Access	R/W	R/W	R/W	R/W	R/W	R/W	R/W	R/W
Reset	0	0	0	0	0	0	0	0

#### Bits 31:0 – CC[31:0] Channel x Compare/Capture Value

These bits contain the compare/capture value in 32-bit TC mode. In Match frequency (MFRQ) or Match PWM (MPWM) waveform operation (WAVE.WAVEGEN), the CC0 register is used as a period register.

#### 44.9.15 Channel x Compare Buffer Value, 32-bit Mode

**Name:** CCBUFx  
**Offset:** 0x30 + x\*0x04 [x=0..1]  
**Reset:** 0x00000000  
**Property:** Write-Synchronized

**Note:** This register is write-synchronized: SYNCBUSY.CCx must be checked to ensure the CCx register synchronization is complete.

Bit	31	30	29	28	27	26	25	24
	CCBUF[31:24]							
Access	R/W	R/W	R/W	R/W	R/W	R/W	R/W	R/W
Reset	0	0	0	0	0	0	0	0
Bit	23	22	21	20	19	18	17	16
	CCBUF[23:16]							
Access	R/W	R/W	R/W	R/W	R/W	R/W	R/W	R/W
Reset	0	0	0	0	0	0	0	0
Bit	15	14	13	12	11	10	9	8
	CCBUF[15:8]							
Access	R/W	R/W	R/W	R/W	R/W	R/W	R/W	R/W
Reset	0	0	0	0	0	0	0	0
Bit	7	6	5	4	3	2	1	0
	CCBUF[7:0]							
Access	R/W	R/W	R/W	R/W	R/W	R/W	R/W	R/W
Reset	0	0	0	0	0	0	0	0

#### Bits 31:0 – CCBUF[31:0] Channel x Compare Buffer Value

These bits hold the value of the Channel x Compare Buffer Value. When the buffer valid flag is '1' and double buffering is enabled (CTRLBCLR.LUPD=1), the data from buffer registers will be copied into the corresponding CCx register under UPDATE condition (CTRLBSET.CMD=0x3), including the software update command.

## 45. Timer/Counter for Control Applications (TCC)

### 45.1 Overview

The device provides five instances of the Timer/Counter for Control applications (TCC) peripheral, TCC[4:0].

Each TCC instance consists of a counter, a prescaler, compare/capture channels and control logic. The counter can be set to count events or clock pulses. The counter together with the compare/capture channels can be configured to time stamp input events, allowing capture of frequency and pulse-width. It can also perform waveform generation, such as frequency generation and pulse-width modulation.

Waveform extensions are featured for motor control, ballast, LED, H-bridge, power converters, and other types of power control applications. They allow for low-side and high-side output with optional dead-time insertion. Waveform extensions can also generate a synchronized bit pattern across the waveform output pins. The fault options enable fault protection for safe and deterministic handling, disabling and/or shut down of external drivers.

**Note:** The TCC configurations, such as channel numbers and features, may be reduced for some of the TCC instances.

### 45.2 Features

The following are key features of the TCC module:

- Up to six Compare/Capture Channels (CC) with:
  - Double buffered period setting
  - Double buffered compare or capture channel
  - Circular buffer on period and compare channel registers
- Waveform Generation:
  - Frequency generation
  - Single-slope pulse-width modulation (PWM)
  - Dual-slope PWM with half-cycle reload capability
- Input Capture:
  - Event capture
  - Frequency capture
  - Pulse-width capture
- Waveform Extensions:
  - Configurable distribution of compare channels outputs across port pins
  - Low-side and high-side output with programmable dead-time insertion
  - Waveform swap option with double buffer support
  - Pattern generation with double buffer support
  - Dithering support
- Fault Protection for Safe Disabling of Drivers:
  - Two recoverable fault sources
  - Two non-recoverable fault sources
  - Debugger can be a source of non-recoverable fault
- Input Events:
  - Two input events (EVx) for counter

- One input event (MCx) for each channel
- Output Events:
  - Three output events (Count, re-trigger and overflow) are available for counter
  - One compare match/input capture event output for each channel
- Interrupts:
  - Overflow and re-trigger interrupt
  - Compare match/input capture interrupt
  - Interrupt on fault detection

The following table lists the features for each TCC instance.

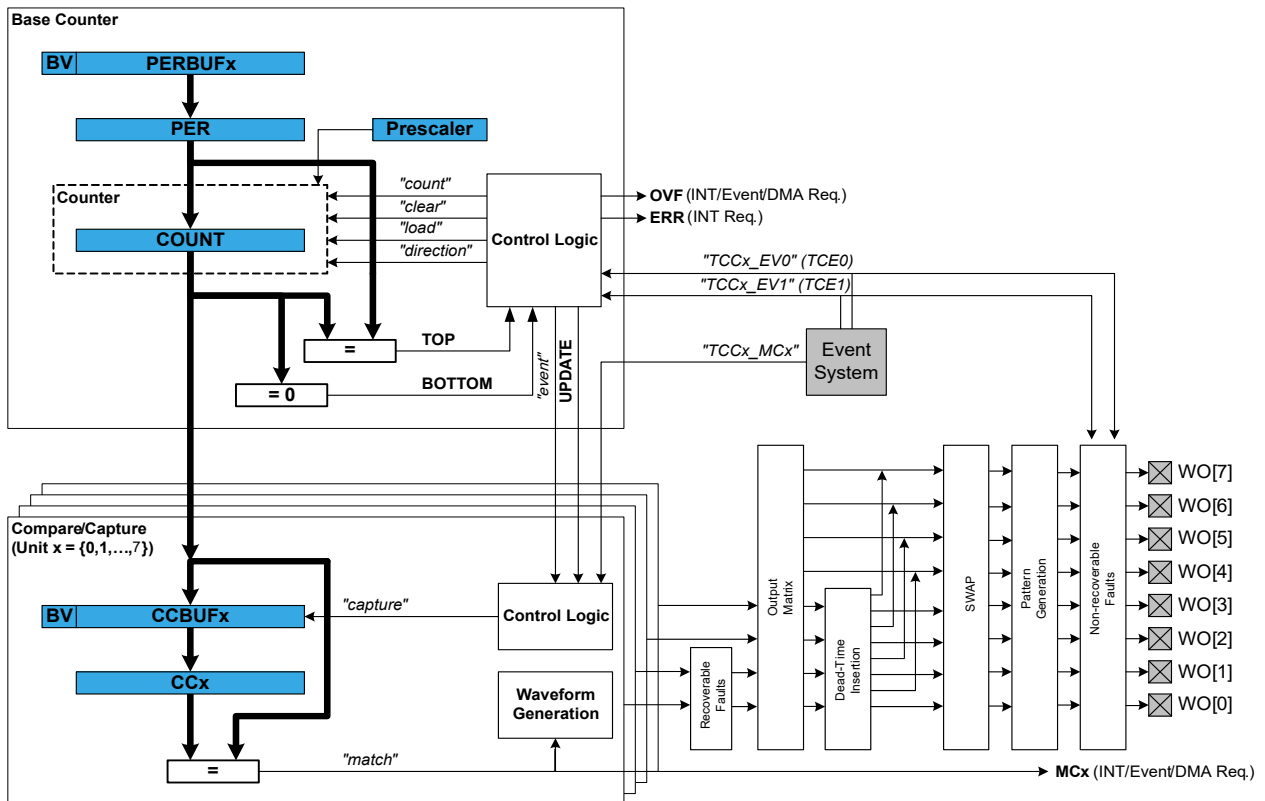
**Table 45-1.** TCC Configuration Summary

TCC#	Channels (CC_NUM)	Waveform Output (WO_NUM)	Counter size	Fault	Dithering	Output matrix	Dead Time Insertion (DTI)	SWAP	Pattern generation
0	6	8	24-bit	Yes	Yes	Yes	Yes	Yes	Yes
1	4	8	24-bit	Yes	Yes	Yes	Yes	Yes	Yes
2	3	3	16-bit	Yes	-	Yes	-	-	-
3	2	2	16-bit	Yes	-	-	-	-	-
4	2	2	16-bit	Yes	-	-	-	-	-

**Note:** The number of CC registers (CC\_NUM) for each TCC corresponds to the number of compare/capture channels, so that a TCC can have more Waveform Outputs (WO\_NUM) than CC registers.

## 45.3 Block Diagram

**Figure 45-1.** Timer/Counter for Control Applications - Block Diagram



## 45.4 Signal Description

Pin Name	Type	Description
TCC/WO[0]	Digital output	Compare channel 0 waveform output
TCC/WO[1]	Digital output	Compare channel 1 waveform output
...	...	...
TCC/WO[7]	Digital output	Compare channel 7 waveform output



I/Os for TCC peripheral are grouped into I/O sets, listed in their 'IOSET' column in the pinout tables.

For these peripherals, it is mandatory to use I/Os that belong to the same I/O set. The timings are not guaranteed when I/Os from different I/O sets are mixed. Refer to the [Pinout and Packaging](#) chapter to get IOSET definitions.

## 45.5 Peripheral Dependencies

<b>Peripheral Name</b>	TCC0 – Timer/Counter for Control Applications 0
<b>Base Address</b>	0x4101_6000 (Peripheral Bus B)
<b>NVIC IRQ Index:Source</b>	85 : CNT , DFS, ERR, FAULTA, FAULTB, FAULT0, FAULT1, OVF, TRG, UFS; 86 : MC0; 87 : MC1; 88 : MC2 89 : MC3; 90 : MC4; 91 : MC5
<b>MCLK APB Clock (1)</b>	CLK_TCC0_APB, Disabled, APBBMASK.TCC0
<b>GCLK Peripheral Channel Index:Clock Name (2)</b>	25 : GCLK_TCC0, GCLK_TCC1
<b>PAC Peripheral Identifier (PAC.WRCTRL)</b>	43
<b>DMA Trigger Index:Source (DMAC.CHCTRLAK,k=0,1,...31)</b>	22 : DMA Overflow/Underflow/Retrigger (OVF) 23-28 : DMA Match/ Compare (MC)
<b>EVSYS Users (EVSYS.USERm) (3)</b>	17,18 : EVx, x=0,1 (TC0 EV0..1) (A,S,R) 19-24 : Match/Compare x, x=0..5 (TCC0 MCx) (A,S,R)
<b>EVSYS Generators (EVSYS.CHANNELn)</b>	41 : Overflow (TCC0_OVF) 42 : Trigger Event (TCC0_TRG) 43 : Counter (TCC0_CNT) 44-49 : Match/Compare x, x=0..5 (TCC0_MCx)

<b>Peripheral Name</b>	TCC1 – Timer/Counter for Control Applications 1
<b>Base Address</b>	0x4101_8000 (Peripheral Bus B)
<b>NVIC IRQ Index:Source</b>	92 : CNT , DFS, ERR, FAULTA, FAULTB, FAULT0, FAULT1, OVF, TRG, UFS; 93 : MC0; 94 : MC1; 95 : MC2; 96 : MC3
<b>MCLK APB Clock (1)</b>	CLK_TCC1_APB, Disabled, APBBMASK.TCC1
<b>GCLK Peripheral Channel Index:Clock Name (2)</b>	25 : GCLK_TCC0, GCLK_TCC1
<b>PAC Peripheral Identifier (PAC.WRCTRL)</b>	44
<b>DMA Trigger Index:Source (DMAC.CHCTRLAK,k=0,1,...31)</b>	29 : DMA Overflow/Underflow/Retrigger (OVF) 30-33 : DMA Match/ Compare (MC)
<b>EVSYS Users (EVSYS.USERm) (3)</b>	25,26 : EVx, x=0,1 (TC1 EV0..1) (A,S,R) 27-30 : Match/Compare x, x=0..3 (TCC1 MCx) (A,S,R)
<b>EVSYS Generators (EVSYS.CHANNELn)</b>	50 : Overflow (TCC1_OVF) 51 : Trigger Event (TCC1_TRG) 52 : Counter (TCC1_CNT) 53-56 : Match/Compare x, x=0..3 (TCC1_MCx)

<b>Peripheral Name</b>	TCC2 – Timer/Counter for Control Applications 2
<b>Base Address</b>	0x4200_0C00 (Peripheral Bus C)
<b>NVIC IRQ Index:Source</b>	97 : CNT, DFS, ERR, FAULTA, FAULTB, FAULT0, FAULT1, OVF, TRG, UFS; 98 : MC0 ; 99 : MC1 ; 100 : MC2
<b>MCLK APB Clock (1)</b>	CLK_TCC2_APB, Disabled, APBCMASK.TCC2
<b>GCLK Peripheral Channel Index:Clock Name (2)</b>	29 : GCLK_TCC2, GCLK_TCC3

<b>PAC Peripheral Peripheral Identifier (PAC.WRCTRL)</b>	67
<b>DMA Trigger Index:Source (DMAC.CHCTRLAK,k=0,1,...31)</b>	34 : DMA Overflow/Underflow/Retrigger (OVF) 35-37 : DMA Match/Compare (MC)
<b>EVSYS Users (EVSYS.USERm) (3)</b>	31,32 : EVx, x=0,1 (TC2 EV0..1) (A,S,R) 33-35 : Match/Compare x, x=0..2 (TCC2 MCx) (A,S,R)
<b>EVSYS Generators (EVSYS.CHANNELn)</b>	57 : Overflow (TCC2_OVF) 58 : Trigger Event (TCC2_TRG) 59 : Counter (TCC2_CNT) 60-62 : Match/Compare x, x=0..2 (TCC2_MCx)

<b>Peripheral Name</b>	TCC3 – Timer/Counter for Control Applications 3
<b>Base Address</b>	0x4200_1000 (Peripheral Bus C)
<b>NVIC IRQ Index:Source</b>	101 : CNT , DFS, ERR, FAULTA, FAULTB, FAULT0, FAULT1, OVF, TRG, UFS; 102 : MC0; 103 : MC1
<b>MCLK APB Clock (1)</b>	CLK_TCC3_APB, Disabled, APBCMASK.TCC3
<b>GCLK Peripheral Channel Index:Clock Name (2)</b>	29 : GCLK_TCC2, GCLK_TCC3
<b>PAC Peripheral Peripheral Identifier (PAC.WRCTRL)</b>	68
<b>DMA Trigger Index:Source (DMAC.CHCTRLAK,k=0,1,...31)</b>	38 : DMA Overflow/Underflow/Retrigger (OVF) 39,40 : DMA Match/Compare (MC)
<b>EVSYS Users (EVSYS.USERm) (3)</b>	36,37 : EVx, x=0,1 (TC3 EV0..1) (A,S,R) 38,39 : Match/Compare x, x=0..1 (TCC3 MCx) (A,S,R)
<b>EVSYS Generators (EVSYS.CHANNELn)</b>	63 : Overflow (TCC3_OVF) 64 : Trigger Event (TCC3_TRG) 65 : Counter (TCC3_CNT) 66,67 : Match/Compare x, x=0,1 (TCC3_MCx)

<b>Peripheral Name</b>	TCC4 – Timer/Counter for Control Applications 4
<b>Base Address</b>	0x4300_1000 (Peripheral Bus D)
<b>NVIC IRQ Index:Source</b>	104 : CNT , DFS, ERR, FAULTA, FAULTB, FAULT0, FAULT1, OVF, TRG, UFS; 105 : MC0; 106 : MC1
<b>MCLK APB Clock (1)</b>	CLK_TCC4_APB, Disabled, APBDMASK.TCC4
<b>GCLK Peripheral Channel Index:Clock Name (2)</b>	38 : GCLK_TCC4
<b>PAC Peripheral Peripheral Identifier (PAC.WRCTRL)</b>	100
<b>DMA Trigger Index:Source (DMAC.CHCTRLAK,k=0,1,...31)</b>	41 : DMA Overflow/Underflow/Retrigger (OVF) 42,43 : DMA Match/Compare (MC)
<b>EVSYS Users (EVSYS.USERm) (3)</b>	40,41 : EVx, x=0,1 (TC4 EV0..1) (A,S,R) 42,43 : Match/Compare x, x=0..1 (TCC4 MCx) (A,S,R)
<b>EVSYS Generators (EVSYS.CHANNELn)</b>	68 : Overflow (TCC4_OVF) 69 : Trigger Event (TCC4_TRG) 70 : Counter (TCC4_CNT) 71,72 : Match/Compare x, x=0,1 (TCC4_MCx)

**Notes:**

1. Clock Name, Default State, Mask Field.
2. See GCLK.PCHCTRLm Register, where m = Index.
3. (A,S,R): A = Asynchronous path, S = Synchronous path, R = Resynchronized path.

**45.5.1 Power Management**

This peripheral can continue to operate in any Sleep mode where its source clock is running. The interrupts can wake up the device from Sleep modes. Events connected to the event system can trigger other operations in the system without exiting Sleep modes.

**45.5.2 Clocks**

The TCC bus clocks (CLK\_TCCx\_APB) can be enabled and disabled in the Main Clock module. The default state of CLK\_TCCx\_APB can be found in the [Peripheral Clock Masking](#) section.

A generic clock (GCLK\_TCCx) is required to clock the TCC. This clock must be configured and enabled in the [Generic Clock Controller](#) before using the TCC.

The generic clocks (GCLK\_TCCx) are asynchronous to the bus clock (CLK\_TCCx\_APB). Due to this asynchronicity, writing certain registers will require synchronization between the clock domains. Refer to [45.6.7. Synchronization](#) for further details.

### 45.5.3 Debug Operation

When the CPU is halted in Debug mode, this peripheral will halt normal operation. This peripheral can be forced to continue operation during debugging - refer to the Debug Control ([45.7.8. DBGCTRL](#)) register for details.

### 45.5.4 Register Access Protection

Registers with write access can be optionally write-protected by the Peripheral Access Controller (PAC), except for the following:

- Interrupt Flag register (INTFLAG)
- Status register (STATUS)
- Period and Period Buffer registers (PER, PERBUF)
- Compare/Capture and Compare/Capture Buffer registers (CCx, CCBUFx)
- Control Waveform register (WAVE)
- Pattern Generation Value and Pattern Generation Value Buffer registers (PATT, PATTBUF)

**Note:** Optional write protection is indicated by the "PAC Write Protection" property in the register description.

Write protection does not apply for accesses through an external debugger.

## 45.6 Functional Description

### 45.6.1 Principle of Operation

The following definitions are used throughout the documentation:

**Table 45-2.** Timer/Counter for Control Applications - Definitions

Name	Description
TOP	The counter reaches TOP when it becomes equal to the highest value in the count sequence. The TOP value can be the same as Period (PER) or the Compare Channel 0 (CC0) register value depending on the Waveform Generator mode in <a href="#">45.6.2.5.1. Waveform Output Generation Operations</a> .
ZERO	The counter reaches ZERO when it contains all zeroes.
MAX	The counter reaches maximum when it contains all ones.
UPDATE	The timer/counter signals an update when it reaches ZERO or TOP, depending on the direction settings.
Timer	The timer/counter clock control is handled by an internal source.
Counter	The clock control is handled externally (e.g., counting external events).
CC	For compare operations, the CC are referred to as "compare channels." For capture operations, the CC are referred to as "capture channels."

Each TCC instance has up to six compare/capture channels (CCx).

The Counter register (COUNT), Period registers with Buffer (PER and PERBUF), and Compare and Capture registers with buffers (CCx and CCBUFx) are 16-bit or 24-bit registers, depending on each TCC instance. Each Buffer register has a Buffer Valid (BUFV) flag that indicates when the buffer contains a new value.

Under normal operation, the counter value is continuously compared to the TOP or ZERO value to determine whether the counter has reached TOP or ZERO. In either case, the TCC can generate



interrupt requests or generate events for the Event System. In Waveform Generator mode, these comparisons are used to set the waveform period or pulse width.

A prescaled generic clock (GCLK\_TCCx) and events from the event system can be used to control the counter. The event system is also used as a source to the input capture.

The Recoverable Fault Unit enables event controlled waveforms by acting directly on the generated waveforms of the TCC compare channels output. These events can restart, halt the timer/counter period, shorten the output pulse active time, or disable waveform output as long as the fault condition is present. This can typically be used for current sensing regulation, and zero-crossing and demagnetization re-triggering.

The MCE0 and MCE1 asynchronous event sources are shared with the recoverable fault unit. Only asynchronous events are used internally when fault unit extension is enabled. For further details on how to configure asynchronous events routing, refer to [EVSYS – Event System](#).

Recoverable fault sources can be filtered and/or windowed to avoid false triggering, for example from I/O pin glitches, by using digital filtering, input blanking, and qualification options. See also [45.6.3.5. Recoverable Faults](#).

In order to support applications with different types of motor control, ballast, LED, H-bridge, power converter, and other types of power switching applications, the following independent units are implemented in some of the TCC instances as optional and successive units:

- Recoverable faults and non-recoverable faults
- Output matrix
- Dead-time insertion
- Swap
- Pattern generation

See also [Figure 45-1](#).

The output matrix (OTMX) can distribute and route out the TCC waveform outputs across the port pins in different configurations, each optimized for different application types. The Dead-Time Insertion (DTI) unit splits the four lower OTMX outputs into two non-overlapping signals: the non-inverted Low Side (LS) and inverted High Side (HS) of the waveform output with optional dead-time insertion between LS and HS switching. The SWAP unit can swap the LS and HS pin outputs, and can be used for fast decay motor control.

The pattern generation unit can be used to generate synchronized waveforms with constant logic level on TCC UPDATE conditions. This is useful for easy stepper motor and full bridge control.

The non-recoverable fault module enables event controlled fault protection by acting directly on the generated waveforms of the timer/counter compare channel outputs. When a non-recoverable fault condition is detected, the output waveforms are forced to a preconfigured value that is safe for the application. This is typically used for instant and predictable shut down and disabling high current or voltage drives.

The count event sources (TCE0 and TCE1) are shared with the non-recoverable fault extension. The events can be optionally filtered. If the filter options are not used, the non-recoverable faults provide an immediate asynchronous action on waveform output, even for cases where the clock is not present. For further details on how to configure asynchronous events routing, refer to the [EVSYS – Event System](#).

## 45.6.2 Basic Operation

### 45.6.2.1 Initialization

The following registers are enable-protected, meaning that they can only be written when the TCC is disabled(CTRLA.ENABLE=0):

- Control A (CTRLA) register, except Run Standby (RUNSTDBY), Enable (ENABLE) and Software Reset (SWRST) bits
- Recoverable Fault n Control registers (FCTRLA and FCTRLB)
- Waveform Extension Control register (WEXCTRL)
- Drive Control register (DRVCTRL)
- Event Control register (EVCTRL)

Enable-protected bits in the CTRLA register can be written at the same time as CTRLA.ENABLE is written to '1', but not at the same time as CTRLA.ENABLE is written to '0'. Enable-protection is denoted by the "Enable-Protected" property in the register description.

Before the TCC is enabled, it must be configured as outlined by the following steps:

1. Enable the TCC bus clock (CLK\_TCCx\_APB).
2. If Capture mode is required, enable the channel in Capture mode by writing a '1' to the Capture Enable bit in the Control A register (CTRLA.CPTEN).

Optionally, the following configurations can be set before enabling TCC:

1. Select PRESCALER setting in the Control A register (CTRLA.PRESCALER).
2. Select Prescaler Synchronization setting in Control A register (CTRLA.PRESCSYNC).
3. If down-counting operation is desired, write the Counter Direction bit in the Control B Set register (CTRLBSET.DIR) to '1'.
4. Select the Waveform Generation operation in the WAVE register (WAVE.WAVEGEN).
5. Select the Waveform Output Polarity in the WAVE register (WAVE.POL).
6. The waveform output can be inverted for the individual channels using the Waveform Output Invert Enable bit group in the Driver register (DRVCTRL.INVEN).

#### 45.6.2.2 Enabling, Disabling, and Resetting

The TCC is enabled by writing a '1' to the Enable bit in the Control A register (CTRLA.ENABLE). The TCC is disabled by writing a zero to CTRLA.ENABLE.

The TCC is reset by writing '1' to the Software Reset bit in the Control A register (CTRLA.SWRST). All registers in the TCC, except DBGCTRL, will be reset to their initial state, and the TCC will be disabled. Refer to Control A ([45.7.1. CTRLA](#)) register for details.

The TCC should be disabled before the TCC is reset to avoid undefined behavior.

#### 45.6.2.3 Prescaler Selection

The GCLK\_TCCx clock is fed into the internal prescaler.

The prescaler consists of a counter that counts up to the selected prescaler value, whereupon the output of the prescaler toggles.

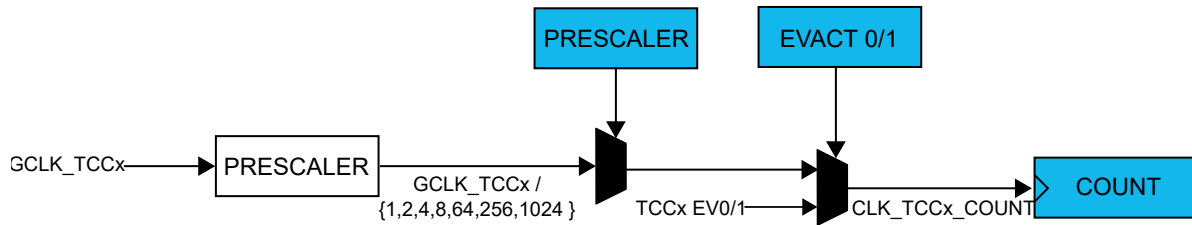
If the prescaler value is higher than one, the Counter Update condition can be optionally executed on the next GCLK\_TCCx clock pulse or the next prescaled clock pulse. For further details, refer to the Prescaler (CTRLA.PRESCALER) and Counter Synchronization (CTRLA.PRESYNC) descriptions.

Prescaler outputs from 1 to 1/1024 are available. For a complete list of available prescaler outputs, see the register description for the Prescaler bit group in the Control A register (CTRLA.PRESCALER).

**Note:** When counting events, the prescaler is bypassed.

The joint stream of prescaler ticks and event action ticks is called CLK\_TCCx\_COUNT.

Figure 45-2. Prescaler



#### 45.6.2.4 Counter Operation

Depending on the mode of operation, the counter is cleared, reloaded, incremented, or decremented at each TCC clock input (CLK\_TCCx\_COUNT). A counter clear or reload mark the end of current counter cycle and the start of a new one.

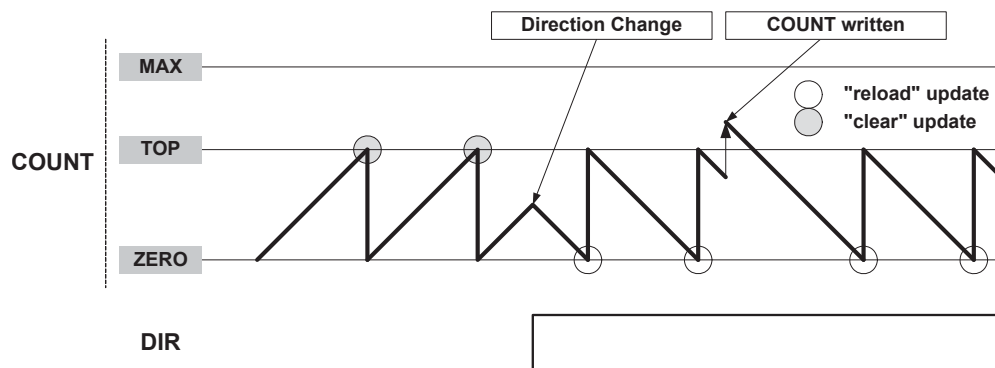
The counting direction is set by the Direction bit in the Control B register (CTRLB.DIR). If the bit is zero, it's counting up and one if counting down.

The counter will count up or down for each tick (clock or event) until it reaches TOP or ZERO. When it's counting up and TOP is reached, the counter will be set to zero at the next tick (overflow) and the Overflow Interrupt Flag in the Interrupt Flag Status and Clear register (INTFLAG.OVF) will be set. When down-counting, the counter is reloaded with the TOP value when '0' is reached (underflow), and the INTFLAG.OVF register is set.

**Note:** When the TCC is counting down, the COUNT register must be initialized to the TOP value (PER or CC0 value depending on the mode).

The INTFLAG.OVF register can be used to trigger an interrupt or an event. An overflow/underflow occurrence (i.e., a compare match with TOP/ZERO) will stop counting if the One-Shot bit in the Control B register is set (CTRLBSET.ONESHOT). The One-Shot feature is explained in the [Additional Features](#) section.

Figure 45-3. Counter Operation



Users can change the counter value (by writing directly in the COUNT register) even when the counter is running. The COUNT value will always be ZERO or TOP, depending on direction set by CTRLBSET.DIR or CTRLBCLR.DIR, when starting the TCC, unless a different value has been written to it, or the TCC has been stopped at a value other than ZERO. The write access has higher priority than count, clear, or reload. The direction of the counter can also be changed during normal operation.

#### Stop Command

A stop command can be issued from software by using TCC Command bits in Control B Set register (CTRLBSET.CMD = 0x2, STOP).

When a stop is detected while the counter is running, the counter will maintain its current value. If the waveform generation (WG) is used, all waveforms are set to a state defined in Non-Recoverable State x Output Enable bit and Non-Recoverable State x Output Value bit in the Driver Control register (DRVCTRL.NREx and DRVCTRL.NRVx), and the Stop bit in the Status register is set (STATUS.STOP).

### Pause Event Action

A pause command can be issued when the stop event action is configured in the Input Event Action 1 bits in Event Control register (EVCTRL.EVACT1 = 0x3, STOP).

When a pause is detected, the counter can stop immediately maintaining its current value and all waveforms keep their current state, as long as a start event action is detected: Input Event Action 0 bits in Event Control register (EVCTRL.EVACT0 = 0x3, START).

### Re-Trigger Command and Event Action

A re-trigger command can be issued from software by using TCC Command bits in Control B Set register (CTRLBSET.CMD = 0x1, RETRIGGER), or from event when the re-trigger event action is configured in the Input Event 0/1 Action bits in Event Control register (EVCTRL.EVACTn = 0x1, RETRIGGER).

When the command is detected during counting operation, the counter will be reloaded or cleared, depending on the counting direction (CTRLBSET.DIR or CTRLBCLR.DIR). The Re-Trigger bit in the Interrupt Flag Status and Clear register will be set (INTFLAG.TRG). It is also possible to generate an event by writing a '1' to the Re-Trigger Event Output Enable bit in the Event Control register (EVCTRL.TRGEO). If the re-trigger command is detected when the counter is stopped, the counter will resume counting operation from the value in COUNT.

#### Note:

When a re-trigger event action is configured in the Event Action bits in the Event Control register (EVCTRL.EVACTn = 0x1, RETRIGGER), enabling the counter will not start the counter. The counter will start on the next incoming event and restart on corresponding following event.

### Start Event Action

The start action can be selected in the Event Control register (EVCTRL.EVACT0 = 0x3, START) and can start the counting operation when previously stopped. The event has no effect if the counter is already counting. When the module is enabled, the counter operation starts when the event is received or when a re-trigger software command is applied.

#### Note:

When a start event action is configured in the Event Action bits in the Event Control register (EVCTRL.EVACT0 = 0x3, START), enabling the counter will not start the counter. The counter will start on the next incoming event, but it will not restart on subsequent events.

### Count Event Action

The TCC can count events. When an event is received, the counter increases or decreases the value, depending on direction settings (CTRLBSET.DIR or CTRLBCLR.DIR).

The count event action is selected by the Event Action 0 bit group in the Event Control register (EVCTRL.EVACT0 = 0x5, COUNT).

### Direction Event Action

The direction event action can be selected in the Event Control register (EVCTRL.EVACT1 = 0x2, DIR). When this event is used, the asynchronous event path specified in the event system must be configured or selected. The direction event action can be used to control the direction of the counter operation, depending on external events level. When received, the event level overrides the Direction settings (CTRLBSET.DIR or CTRLBCLR.DIR) and the direction bit value is updated accordingly.

### Increment Event Action

The increment event action can be selected in the Event Control register (EVCTRL.EVACT0 = 0x4, INC) and can change the Counter state when an event is received. When the TCE0 event (TCCx\_EV0) is received, the counter increments, whatever the direction setting (CTRLBSET.DIR or CTRLBCLR.DIR) is.

### Decrement Event Action

The decrement event action can be selected in the Event Control register (EVCTRL.EVACT1 = 0x4, DEC) and can change the Counter state when an event is received. When the TCE1 (TCCx\_EV1) event is received, the counter decrements, whatever the direction setting (CTRLBSET.DIR or CTRLBCLR.DIR) is.

### Non-recoverable Fault Event Action

Non-recoverable fault actions can be selected in the Event Control register (EVCTRL.EVACTn = 0x7, FAULT). When received, the counter will be stopped and the output of the compare channels is overridden according to the Driver Control register settings (DRVCTRL.NREx and DRVCTRL.NRVx). TCE0 and TCE1 must be configured as asynchronous events.

### Event Action Off

If the event action is disabled (EVCTRL.EVACTn = 0x0, OFF), enabling the counter will also start the counter.

## 45.6.2.5 Compare Operations

By default, the Compare or Capture channel is configured for compare operations. To perform capture operations, it must be re-configured.

When using the TCC with the Compare/Capture Value registers (CCx) for compare operations, the counter value is continuously compared to the values in the CCx registers. This can be used for timer or for waveform operation.

The Channel x Compare/Capture Buffer Value (CCBUFx) registers provide double buffer capability. The double buffering synchronizes the update of the CCx register with the buffer value at the UPDATE condition or a force update command (CTRLBSET.CMD = 0x3, UPDATE). For additional information, refer to [45.6.2.6. Double Buffering](#). The synchronization prevents the occurrence of odd-length, non-symmetrical pulses and ensures glitch-free output.

### 45.6.2.5.1 Waveform Output Generation Operations

The compare channels can be used for waveform generation on output port pins. To make the waveform available on the connected pin, the following requirements must be fulfilled:

1. Choose a Waveform Generation mode in the Waveform Generation Operation bit in Waveform register (WAVE.WAVEGEN).
2. Optionally invert the waveform output WO[x] by writing the corresponding Waveform Output x Inversion bit in the Driver Control register (DRVCTRL.INVENx).
3. Configure the pins with the I/O Pin Controller. Refer to [PORT - I/O Pin Controller](#) for details.  
**Note:** Event must not be used when the compare channel is set in waveform output operating mode.

The counter value is continuously compared with each CCx value. On a comparison match, the Match or Capture Channel x bit in the Interrupt Flag Status and Clear register (INTFLAG.MCx) will be set on the next zero-to-one transition of CLK\_TCC\_COUNT (see Normal Frequency Operation). An interrupt and/or event can be generated on the same condition if Match/Capture occurs, i.e. INTENSET.MCx and/or EVCTRL.MCEOx is '1'. Both interrupt and event can be generated simultaneously.

There are seven waveform configurations for the Waveform Generation Operation bit group in the Waveform register (WAVE.WAVEGEN). This will influence how the waveform is generated and impose restrictions on the top value. The configurations are:

- Normal Frequency (NFRQ)
- Match Frequency (MFRQ)
- Normal Pulse-Width Modulation (NPWM)
- Dual-slope, interrupt/event at TOP (DSTOP)
- Dual-slope, interrupt/event at ZERO (DSBOTTOM)
- Dual-slope, interrupt/event at Top and ZERO (DSBOTH)
- Dual-slope, critical interrupt/event at ZERO (DSCRITICAL)

When using MFRQ configuration, the TOP value is defined by the CC0 register value. For the other waveform operations, the TOP value is defined by the Period (PER) register value.

For dual-slope waveform operations, the update time occurs when the counter reaches ZERO. For the other Waveforms Generation modes, the update time occurs on counter wraparound, on overflow, underflow, or re-trigger.

The table below shows the update counter and overflow event/interrupt generation conditions in different operation modes.

**Table 45-3.** Counter Update and Overflow Event/interrupt Conditions

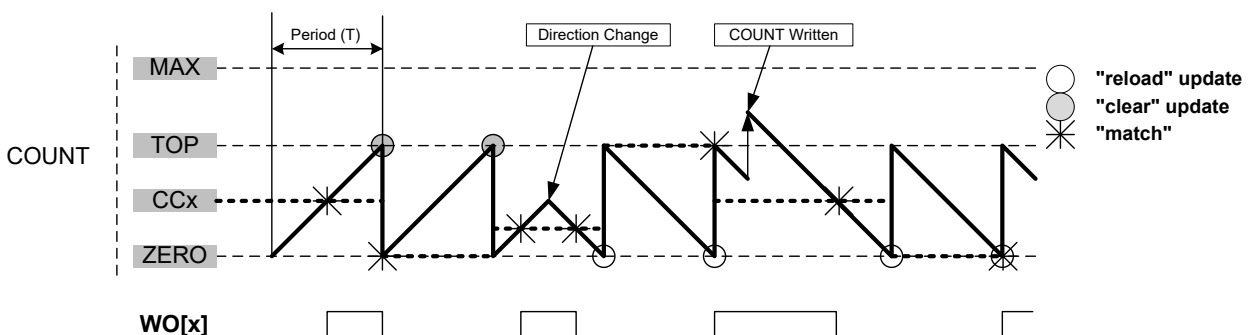
Name	Operation	TOP	Update	Output Waveform		OVFIF/Event	
				On Match	On Update	Up	Down
NFRQ	Normal Frequency	PER	TOP/ ZERO	Toggle	Stable	TOP	ZERO
MFRQ	Match Frequency	CC0	TOP/ ZERO	Toggle	Stable	TOP	ZERO
NPWM	Single-slope PWM	PER	TOP/ ZERO	See section 'Output Polarity' below		TOP	ZERO
DSCRITICAL	Dual-slope PWM	PER	ZERO			-	ZERO
DSBOTTOM	Dual-slope PWM	PER	ZERO			-	ZERO
DSBOTH	Dual-slope PWM	PER	TOP <sup>(1)</sup> & ZERO			TOP	ZERO
DSTOP	Dual-slope PWM	PER	ZERO			TOP	-

1. The UPDATE condition on TOP only will occur when circular buffer is enabled for the channel.

#### 45.6.2.5.2 Normal Frequency (NFRQ)

For Normal Frequency generation, the period time (T) is controlled by the period register (PER). The waveform generation output (WO[x]) is toggled on each compare match between COUNT and CCx, and the corresponding Match or Capture Channel x Interrupt Flag (EVCTRL.MCE0x) will be set.

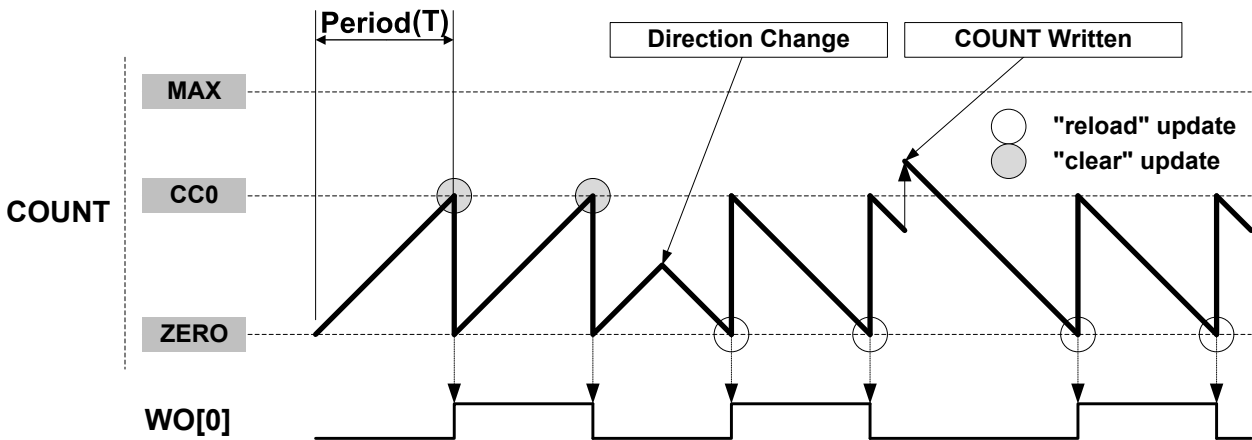
**Figure 45-4.** Normal Frequency Operation



### 45.6.2.5.3 Match Frequency (MFRQ)

For Match Frequency generation, the period time (T) is controlled by CC0 register instead of PER. WO[0] toggles on each update condition.

Figure 45-5. Match Frequency Operation



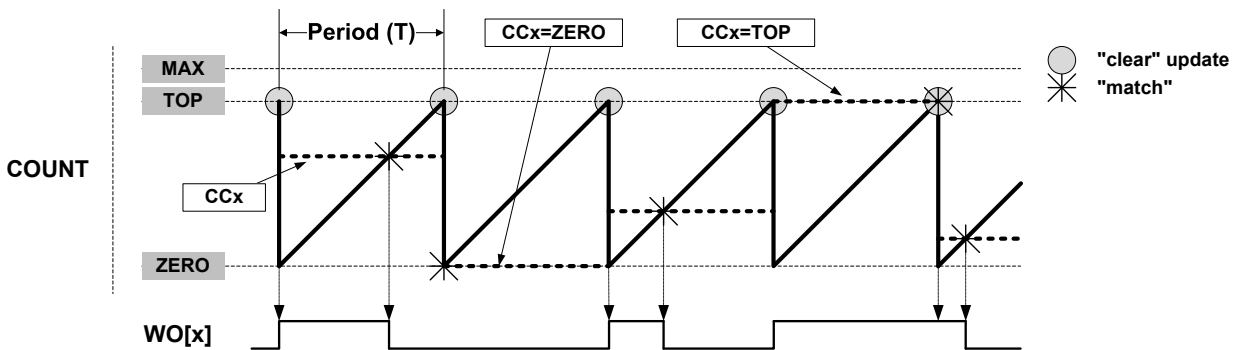
### 45.6.2.5.4 Normal Pulse-Width Modulation (NPWM)

NPWM uses single-slope PWM generation.

### 45.6.2.5.5 Single-Slope PWM Operation

For single-slope PWM generation, the period time (T) is controlled by Top value, and CCx controls the duty cycle of the generated waveform output. When up-counting, the WO[x] is set at start or compare match between the COUNT and TOP values, and cleared on compare match between COUNT and CCx register values. When down-counting, the WO[x] is cleared at start or compare match between the COUNT and ZERO values, and set on compare match between COUNT and CCx register values.

Figure 45-6. Single-Slope PWM Operation



The following equation calculates the exact resolution for a single-slope PWM ( $R_{P_{PWM\_SS}}$ ) waveform:

$$R_{P_{PWM\_SS}} = \frac{\log(TOP+1)}{\log(2)}$$

The PWM frequency depends on the Period register value (PER) and the peripheral clock frequency ( $f_{GCLK\_TCCx}$ ), and can be calculated by the following equation:

$$f_{P_{PWM\_SS}} = \frac{f_{GCLK\_TCCx}}{N(TOP+1)}$$

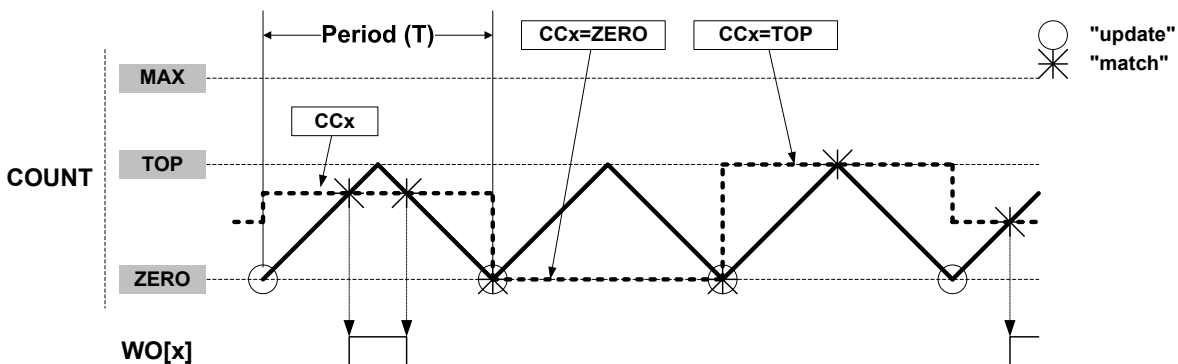
Where N represents the prescaler divider used (1, 2, 4, 8, 16, 64, 256, 1024).

#### 45.6.2.5.6 Dual-Slope PWM Generation

For dual-slope PWM generation, the period setting (TOP) is controlled by PER, while CCx control the duty cycle of the generated waveform output. The figure below shows how the counter repeatedly counts from ZERO to PER and then from PER to ZERO. The waveform generator output is set on compare match when up-counting, and cleared on compare match when down-counting. An interrupt and/or event is generated on TOP (when counting upwards) and/or ZERO (when counting up or down).

In DSBOTH operation, the circular buffer must be enabled to enable the update condition on TOP.

**Figure 45-7.** Dual-Slope Pulse Width Modulation



Using dual-slope PWM results in a lower maximum operation frequency compared to single-slope PWM generation. The period (TOP) defines the PWM resolution. The minimum resolution is 1 bit (TOP=0x00000001).

The following equation calculates the exact resolution for dual-slope PWM ( $R_{PWM\_DS}$ ):

$$R_{PWM\_DS} = \frac{\log(PER+1)}{\log(2)}$$

The PWM frequency  $f_{PWM\_DS}$  depends on the period setting (TOP) and the peripheral clock frequency  $f_{GCLK\_TCCx}$ , and can be calculated by the following equation:

$$f_{PWM\_DS} = \frac{f_{GCLK\_TCCx}}{2N \cdot PER}$$

$N$  represents the prescaler divider used. The waveform generated will have a maximum frequency of half of the TCC clock frequency ( $f_{GCLK\_TCCx}$ ) when TOP is set to 0x00000001 and no prescaling is used.

The pulse width ( $P_{PWM\_DS}$ ) depends on the compare channel (CCx) register value and the peripheral clock frequency ( $f_{GCLK\_TCCx}$ ), and can be calculated by the following equation:

$$P_{PWM\_DS} = \frac{2N \cdot (TOP - CCx)}{f_{GCLK\_TCCx}}$$

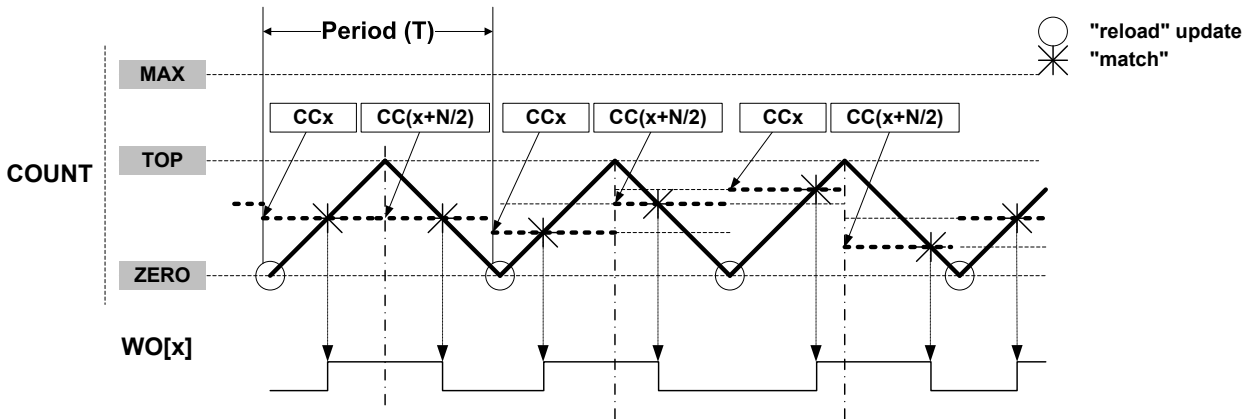
$N$  represents the prescaler divider used.

**Note:** In DSTOP, DSBOTTOM and DSBOTH operation, when TOP is lower than MAX/2, the CCx MSB bit defines the ramp on which the CCx Match interrupt or event is generated. (Rising if CCx[MSB] = 0, falling if CCx[MSB] = 1.)

#### 45.6.2.5.7 Dual-Slope Critical PWM Generation

Critical mode generation allows generation of non-aligned centered pulses. In this mode, the period time is controlled by PER while CCx control the generated waveform output edge during up-counting and CC(x+CC\_NUM/2) control the generated waveform output edge during down-counting.



Figure 45-8. Dual-Slope Critical Pulse Width Modulation ( $N=CC\_NUM$ )

#### 45.6.2.5.8 Output Polarity

The polarity (WAVE.POL<sub>x</sub>) is available in all waveform output generation. In single-slope and dual-slope PWM operation, it is possible to invert the pulse edge alignment individually on start or end of a PWM cycle for each compare channels. The table below shows the waveform output set/clear conditions, depending on the settings of timer/counter, direction, and polarity.

Table 45-4. Waveform Generation Set/Clear Conditions

Waveform Generation Operation	DIR	POL <sub>x</sub>	Waveform Generation Output Update	
			Set	Clear
Single-Slope PWM	0	0	Timer/counter matches TOP	Timer/counter matches CC <sub>x</sub>
		1	Timer/counter matches CC	Timer/counter matches TOP
	1	0	Timer/counter matches CC	Timer/counter matches ZERO
		1	Timer/counter matches ZERO	Timer/counter matches CC
Dual-Slope PWM	x	0	Timer/counter matches CC when counting up	Timer/counter matches CC when counting down
		1	Timer/counter matches CC when counting down	Timer/counter matches CC when counting up

In Normal and Match Frequency, the WAVE.POL<sub>x</sub> value represents the initial state of the waveform output.

#### 45.6.2.6 Double Buffering

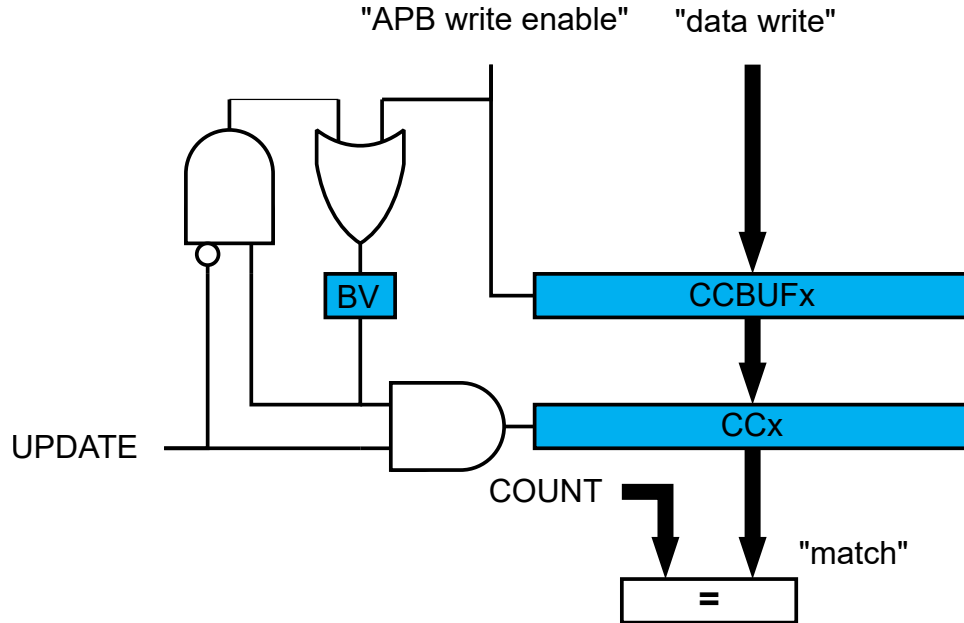
The Pattern (PATT), Period (PER) and Compare Channels (CC<sub>x</sub>) registers are all double buffered. Each buffer register has a buffer valid (PATTBUFV, PERBUFV and CCBUFV<sub>x</sub>) bit in the STATUS register, which indicates that the Buffer register contains a valid value that can be copied into the corresponding register. As long as the respective Buffer Valid Status flag (PATTBUFV, PERBUFV or CCBUFV<sub>x</sub>) are set to '1', the related SYNCBUSY bits are set (SYNCBUSY.PATT, SYNCBUSY.PER or SYNCBUSY.CC<sub>x</sub>), a write to the respective PATT/PATTBUF, PER/PERBUF or CC<sub>x</sub>/CCBUF<sub>x</sub> registers will generate a PAC error, and read access to the respective PATT, PER or CC<sub>x</sub> register is invalid.

When the Buffer Valid Flag bit in the STATUS register is '1' and the Lock Update bit in the CTRLB register is set to '0', (writing CTRLBCLR.LUPD to '1'), double buffering is enabled: the data from buffer registers will be copied into the corresponding register under hardware UPDATE conditions, then the Buffer Valid flags bit in the STATUS register are automatically cleared by hardware.

**Note:** Software update command (CTRLBSET.CMD=0x3) act independently of LUPD value.

A compare register is double buffered as in the following figure.

Figure 45-9. Compare Channel Double Buffering



Both the registers (PATT/PER/CCx) and corresponding Buffer registers (PATTBUFPERBUF/CCBUFx) are available in the I/O register map, and the double buffering feature is not mandatory. The double buffering is disabled by writing a '1' to CTRLSET.LUPD.

**Note:** In NFRQ, MFRQ or PWM Down-Counting Counter mode (CTRLBSET.DIR=1), when double buffering is enabled (CTRLBCLR.LUPD=1), PERBUF register is continuously copied into the PER independently of update conditions.

### Changing the Period

The counter period can be changed by writing a new Top value to the Period register (PER or CC0, depending on the Waveform Generation mode), any period update on registers (PER or CCx) is effective after the synchronization delay, whatever double buffering enabling is.

Figure 45-10. Unbuffered Single-Slope Up-Counting Operation

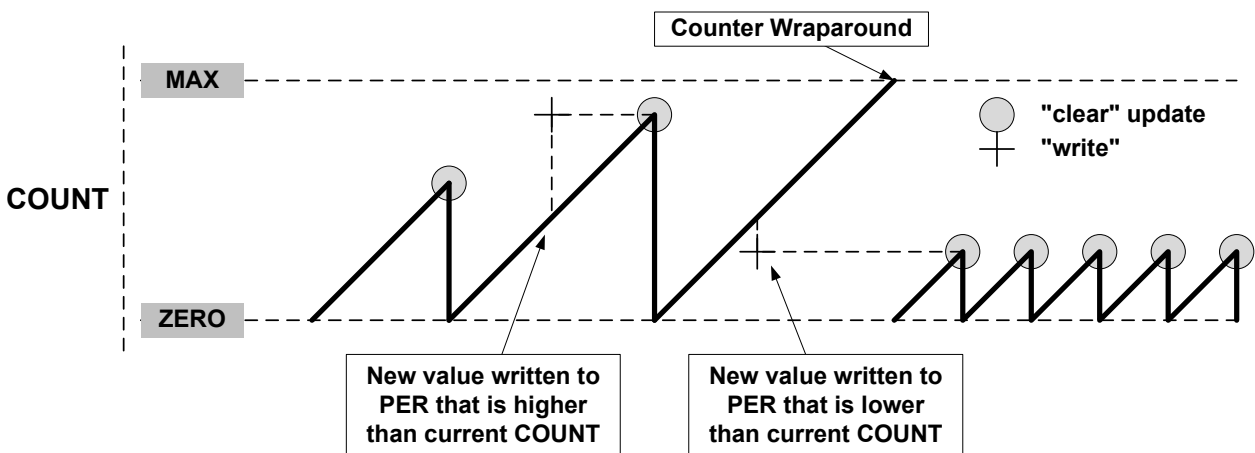
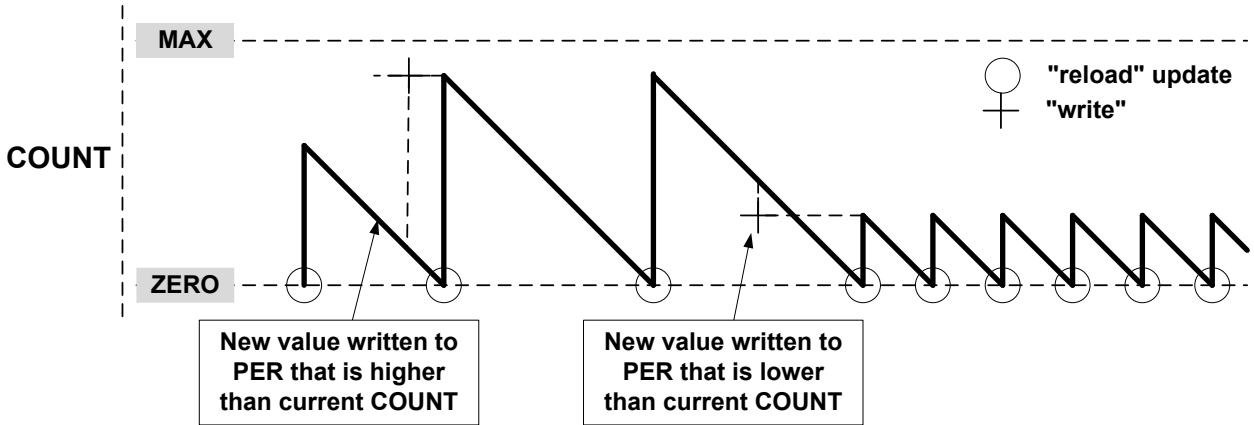
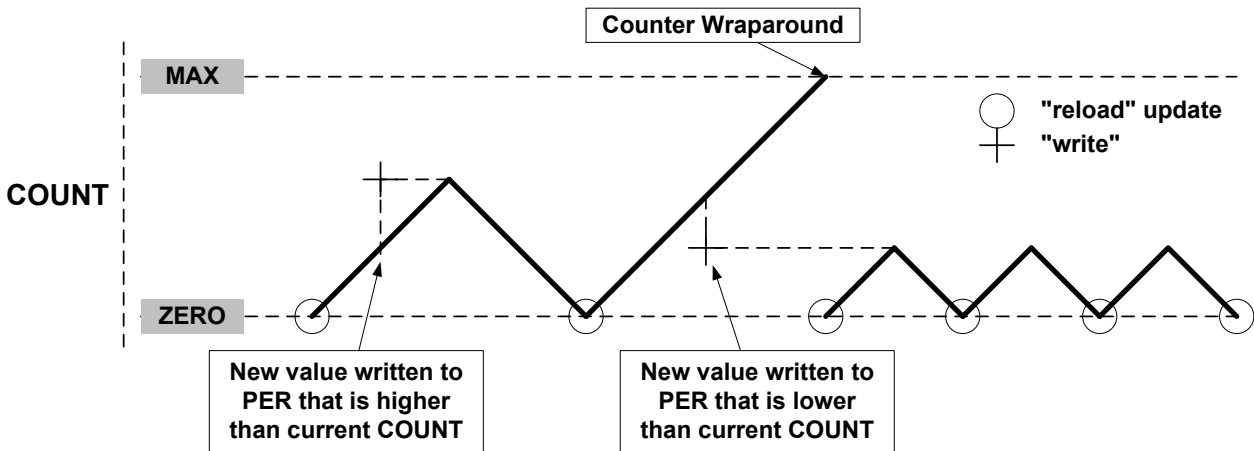


Figure 45-11. Unbuffered Single-Slope Down-Counting Operation



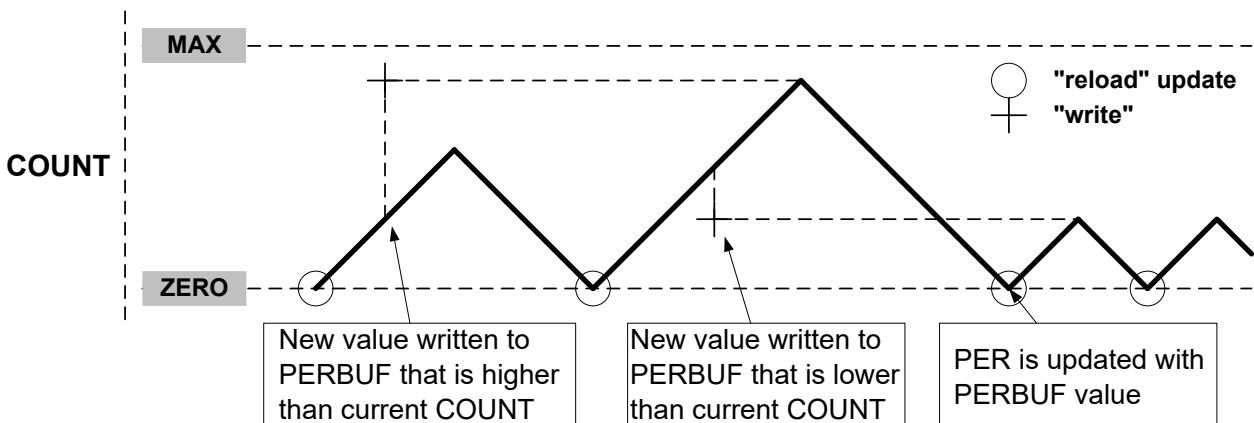
A counter wraparound can occur in any operation mode when up-counting without buffering, see the figure, above. COUNT and TOP are continuously compared, so when a new value that is lower than the current COUNT is written to TOP, COUNT will wrap before a compare match.

Figure 45-12. Unbuffered Dual-Slope Operation



When double buffering is used, the buffer can be written at any time and the counter will still maintain correct operation. The period register is always updated on the update condition, as shown in the following figure. This prevents wraparound and the generation of odd waveforms.

Figure 45-13. Changing the Period Using Buffering



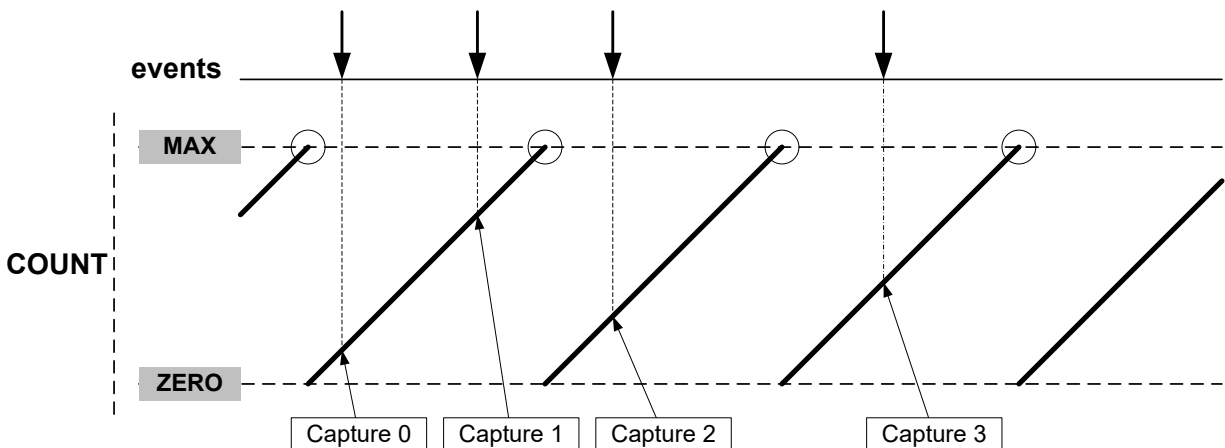
### 45.6.2.7 Capture Operations

To enable and use capture operations, the Match or Capture Channel x Event Input Enable bit in the Event Control register (EVCTRL.MCEIx) must be written to '1'. The capture channels to be used must also be enabled in the Capture Channel x Enable bit in the Control A register (CTRLA.CPTENx) before capturing can be performed.

#### Event Capture Action

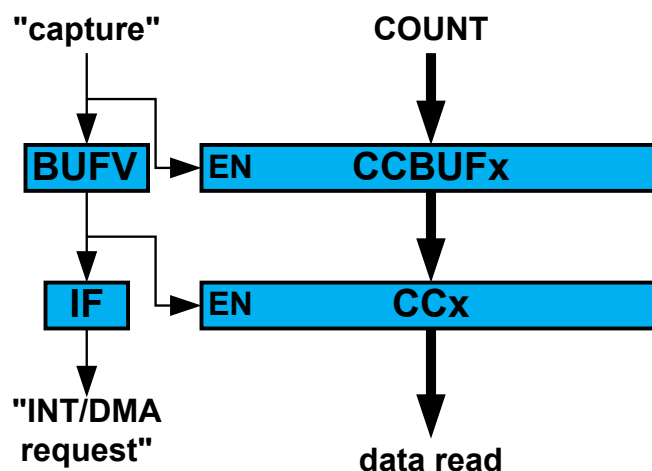
The compare/capture channels can be used as input capture channels to capture events from the Event System, and give them a timestamp. The following figure shows four capture events for one capture channel. Event system channels must be configured to operate in asynchronous mode when used for capture operations.

Figure 45-14. Input Capture Timing



For input capture, the Buffer register and the corresponding CCx act like a FIFO. When CCx is empty or read, any content in CCBUFx is transferred to CCx. The Buffer Valid flag is passed to set the CCx Interrupt flag (IF) and generate the optional interrupt, event, or DMA request. The CCBUFx register value cannot be read, all captured data must be read from the CCx register.

Figure 45-15. Capture Double Buffering



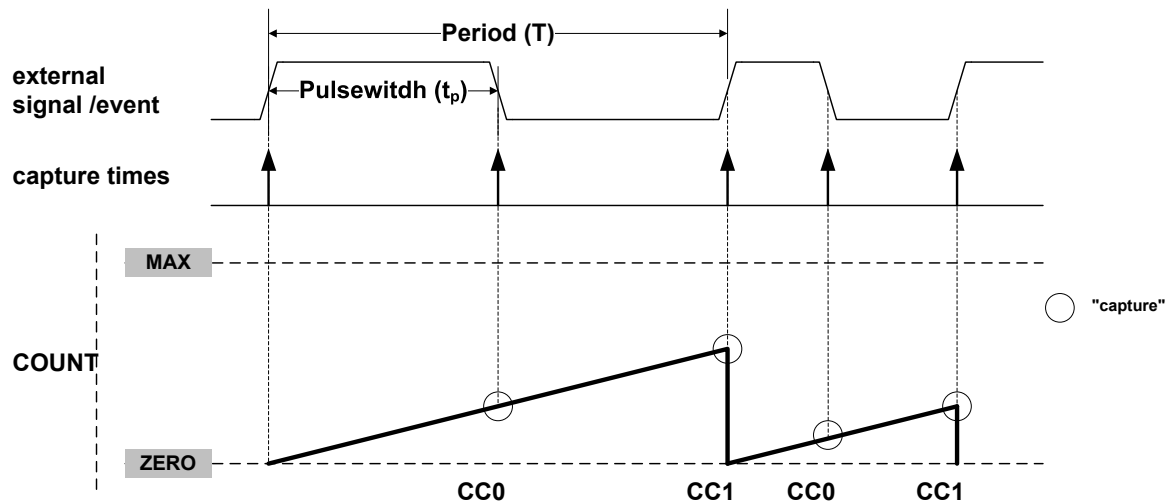
The TCC can detect capture overflow of the input capture channels. When a new capture event is detected while the Capture Buffer Valid flag (STATUS.CCBUFV) is still set, the new timestamp will not be stored and INTFLAG.ERR will be set.

## Period and Pulse-Width (PPW) Capture Action

The TCC can perform two input captures and restart the counter on one of the edges. This enables the TCC to measure the pulse-width and period and to characterize the frequency  $f$  and  $dutyCycle$  of an input signal, as shown below:

$$f = \frac{1}{T} \quad , \quad dutyCycle = \frac{t_p}{T}$$

Figure 45-16. PWP Capture



Selecting PWP or PPW in the Timer/Counter Event Input 1 Action bit group in the Event Control register (EVCTRL.EVACT1) enables the TCC to perform one capture action on the rising edge and the other one on the falling edge. When using PPW event action, period  $T$  will be captured into CC0 and the pulse-width  $t_p$  into CC1. The PWP (Pulse-width and Period) event action offers the same functionality, but  $T$  will be captured into CC1 and  $t_p$  into CC0.

The Timer/Counter Event  $x$  Invert Enable bit in Event Control register (EVCTRL.TCEIN $x$ ) is used for event source  $x$  to select whether the wraparound should occur on the rising edge or the falling edge. If EVCTRL.TCEIN $x$ =1, the wraparound will happen on the falling edge.

The corresponding capture is done only if the channel is enabled in Capture mode (CTRLA.CPTEN $x$ =1). If not, the capture action will be ignored and the channel will be enabled in compare mode of operation. When only one of these channel is required, the other channel can be used for other purposes.

The TCC can detect capture overflow of the input capture channels. When a new capture event is detected while the INTFLAG.MC $x$  is still set, the new timestamp will not be stored and INTFLAG.ERR will be set.

**Note:** When up-counting (CTRLBSET.DIR=0), counter values lower than 1 cannot be captured in Capture Minimum mode (FCTRLn.CAPTURE=CAPTMIN). To capture the full range including value 0, the TCC must be configured in Down-counting mode (CTRLBSET.DIR=0).

**Note:** In dual-slope PWM operation, and when TOP is lower than MAX/2, the CC $x$  MSB captures the CTRLB.DIR state to identify the ramp on which the capture has been done. For rising ramps CC $x$ [MSB] is zero, for falling ramps CC $x$ [MSB]=1.

### 45.6.3 Additional Features

#### 45.6.3.1 One-Shot Operation

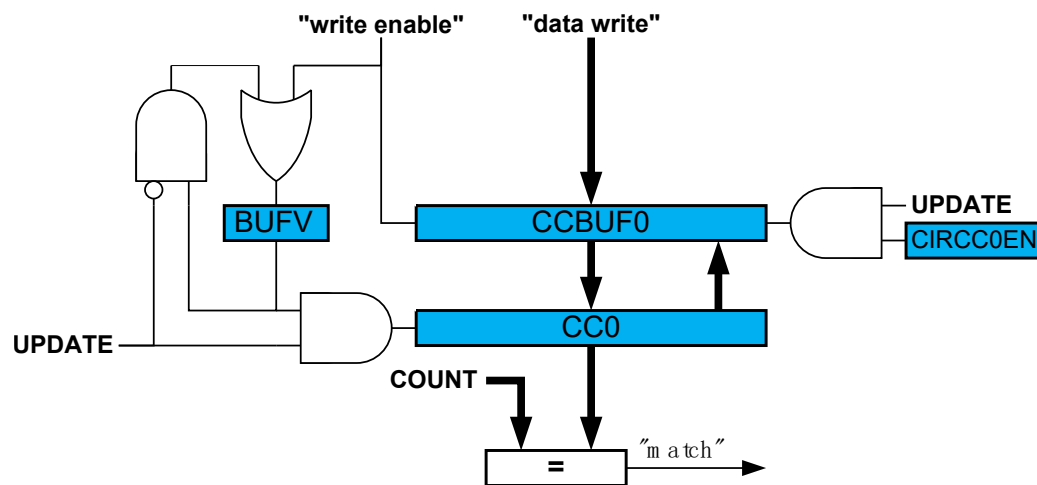
When one-shot is enabled, the counter automatically stops on the next Counter Overflow or Underflow condition. When the counter is stopped, the Stop bit in the Status register (STATUS.STOP) is set and the waveform outputs are set to the value defined by DRVCTRL.NREx and DRVCTRL.NRVx.

One-shot operation can be enabled by writing a '1' to the One-Shot bit in the Control B Set register (CTRLBSET.ONESHOT) and disabled by writing a '1' to CTRLBCLR.ONESHOT. When enabled, the TCC will count until an overflow or underflow occurs and stop counting. The one-shot operation can be restarted by a re-trigger software command, a re-trigger event or a start event. When the counter restarts its operation, STATUS.STOP is automatically cleared.

#### 45.6.3.2 Circular Buffer

The Period register (PER) and the Compare Channels register (CC0 to CC5) support circular buffer operation. When circular buffer operation is enabled, the PER or CCx values are copied into the corresponding buffer registers at each update condition. Circular buffering is dedicated to RAMP2, RAMP2A, and DSBOOTH operations.

Figure 45-17. Circular Buffer on Channel 0



#### 45.6.3.3 Dithering Operation

The TCC supports dithering on Pulse-width or Period on a 16, 32 or 64 PWM cycles frame.

Dithering consists in adding some extra clock cycles in a frame of several PWM cycles, and can improve the accuracy of the *average* output pulse width and period. The extra clock cycles are added on some of the compare match signals, one at a time, through a "blue noise" process that minimizes the flickering on the resulting dither patterns.

**Note:** The use of dithering with an external retrigger event (EVCTRL.EVACTx) is not supported.

Dithering is enabled by writing the corresponding configuration in the Enhanced Resolution bits in CTRLA register (CTRLA.RESOLUTION):

- DITH4 enable dithering every 16 PWM frames
- DITH5 enable dithering every 32 PWM frames
- DITH6 enable dithering every 64 PWM frames

The DITHERCY bits of COUNT, PER and CCx define the number of extra cycles to add into the frame (DITHERCY bits from the respective COUNT, PER or CCx registers). The remaining bits of COUNT, PER, CCx define the compare value itself.

The pseudo code, giving the extra cycles insertion regarding the cycle is:

```
int extra_cycle(resolution, dithercy, cycle){
    int MASK;
    int value
    switch (resolution){
        DITH4: MASK = 0x0f;
        DITH5: MASK = 0x1f;
        DITH6: MASK = 0x3f;
    }
    value = cycle * dithercy;
    if ((MASK & value) + dithercy) > MASK)
        return 1;
    return 0;
}
```

### Dithering on Period

Writing DITHERCY in PER will lead to an average PWM period configured by the following formulas.

DITH4 mode:

$$PwmPeriod = \left( \frac{DITHERCY}{16} + PER \right) \left( \frac{1}{f_{GCLK\_TCCx}} \right)$$

**Note:** If DITH4 mode is enabled, the last 4 significant bits from PER/CCx or COUNT register correspond to the DITHERCY value, rest of the bits corresponds to PER/CCx or COUNT value.

DITH5 mode:

$$PwmPeriod = \left( \frac{DITHERCY}{32} + PER \right) \left( \frac{1}{f_{GCLK\_TCCx}} \right)$$

DITH6 mode:

$$PwmPeriod = \left( \frac{DITHERCY}{64} + PER \right) \left( \frac{1}{f_{GCLK\_TCCx}} \right)$$

### Dithering on Pulse-Width

Writing DITHERCY in CCx will lead to an average PWM pulse width configured by the following formula.

DITH4 mode:

$$PwmPulseWidth = \left( \frac{DITHERCY}{16} + CCx \right) \left( \frac{1}{f_{GCLK\_TCCx}} \right)$$

DITH5 mode:

$$PwmPulseWidth = \left( \frac{DITHERCY}{32} + CCx \right) \left( \frac{1}{f_{GCLK\_TCCx}} \right)$$

DITH6 mode:

$$PwmPulseWidth = \left( \frac{DITHERCY}{64} + CCx \right) \left( \frac{1}{f_{GCLK\_TCCx}} \right)$$

**Note:** The PWM period will remain static in this case.

#### 45.6.3.4 Ramp Operations

Three ramp operation modes are supported. All of them require the timer/counter running in single-slope PWM generation. The Ramp mode is selected by writing to the Ramp Mode bits in the Waveform Control register (WAVE.RAMP).

##### RAMP1 Operation

This is the default PWM operation, described in [Single-Slope PWM Generation](#).

## RAMP2 Operation

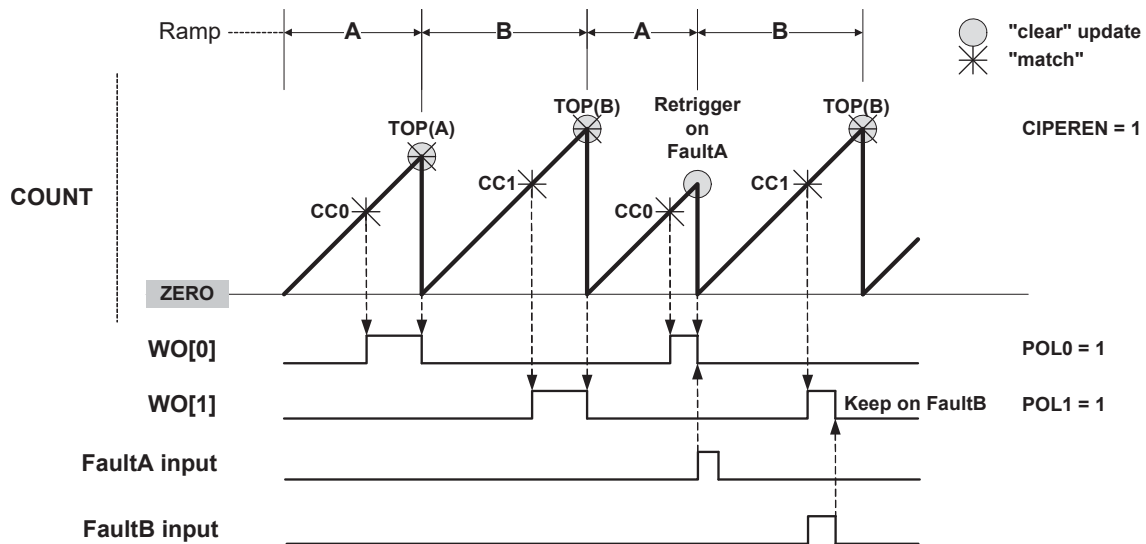
These operation modes are dedicated for power factor correction (PFC), Half-Bridge and Push-Pull SMPS topologies, where two consecutive timer/counter cycles are interleaved, see the figure, *RAMP2 Standard Operation*, below. In cycle A, odd channel output is disabled, and in cycle B, even channel output is disabled. The ramp index changes after each update, but can be software modified using the Ramp index command bits in Control B Set register (CTRLBSET.IDXCMD).

**Note:** All RAMP2 operations only support counting up mode (CTRLB.DIR = 0).

### Standard RAMP2 (RAMP2) Operation

Ramp A and B periods are controlled by the PER register value. The PER value can be different on each ramp by the Circular Period buffer option in the Wave register (WAVE.CIPEREN=1). This mode uses a two-channel TCC to generate two output signals, or one output signal with another CC channel enabled in Capture mode.

Figure 45-18. RAMP2 Standard Operation

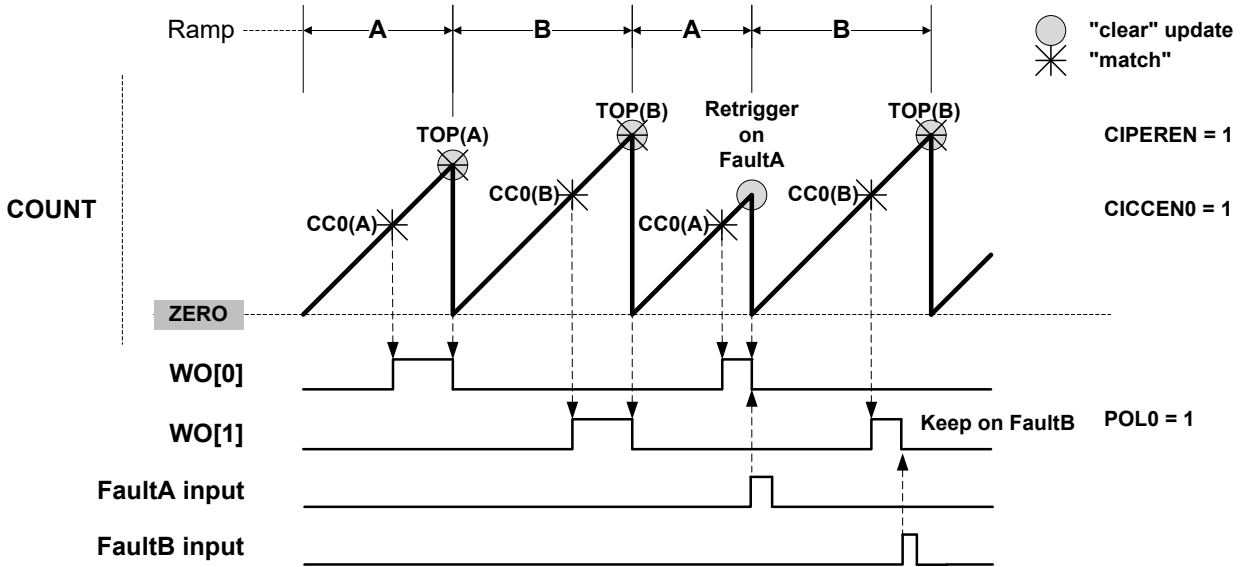


### Alternate RAMP2 (RAMP2A) Operation

Alternate RAMP2 operation is similar to RAMP2, but CC0 controls both WO[0] and WO[1] waveforms when the corresponding circular buffer option is enabled (CIPEREN=1). The waveform polarity is the same on both outputs. Channel 1 can be used in capture mode.



Figure 45-19. RAMP2 Alternate Operation



### Critical RAMP2 (RAMP2C) Operation

Critical RAMP2 operation provides a way to cover RAMP2 operation requirements without the update constraint associated with the use of circular buffers. In this mode, CC0 is controlling the period of ramp A and PER is controlling the period of ramp B. When using more than two channels, WO[0] output is controlled by CC2 (HIGH) and CC0 (LOW). On TCC with 2 channels, a pulse on WO[0] will last the entire period of ramp A, if WAVE.POL0=0.

Figure 45-20. RAMP2 Critical Operation With More Than 2 Channels

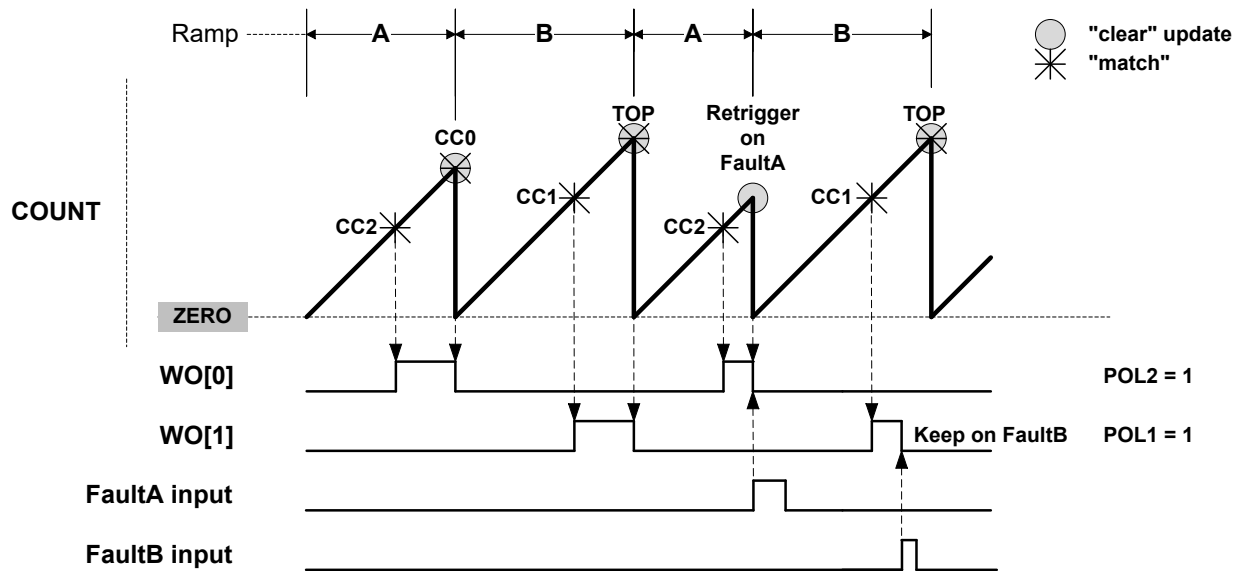
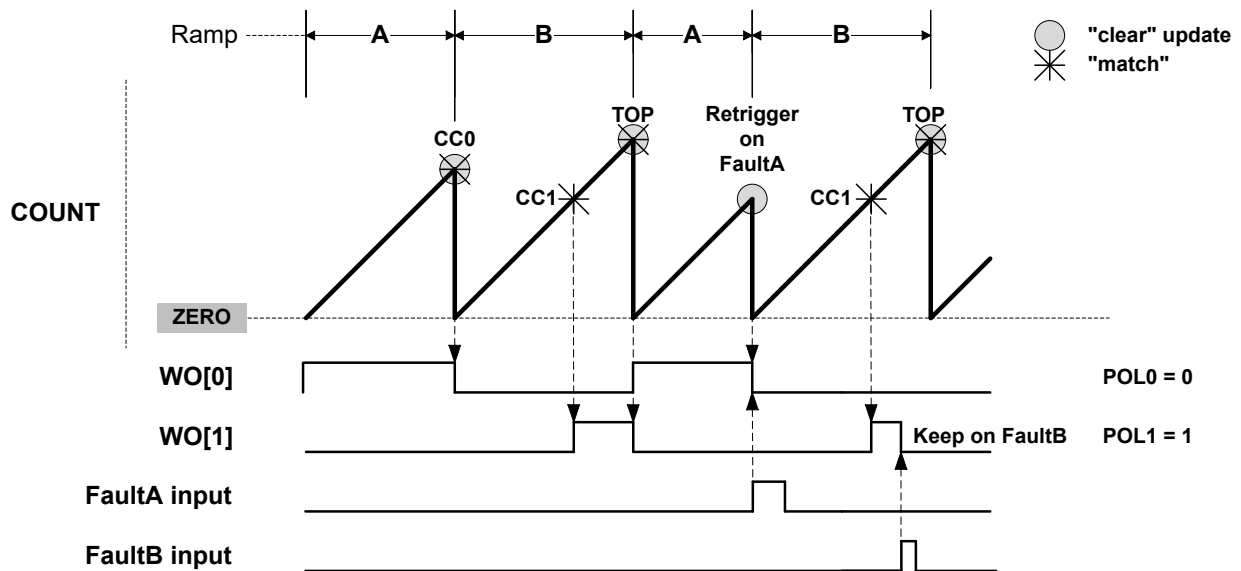


Figure 45-21. RAMP2 Critical Operation With 2 Channels



#### 45.6.3.5 Recoverable Faults

Recoverable faults can restart or halt the timer/counter. Two faults, called Fault A and Fault B, can trigger recoverable fault actions on the compare channels CC0 and CC1 of the TCC. The compare channels' outputs can be clamped to inactive state either as long as the fault condition is present, or from the first valid fault condition detection on until the end of the timer/counter cycle.

##### Fault Inputs

The first two channel input events (TCCxMC0 and TCCxMC1) can be used as Fault A and Fault B inputs, respectively. Event system channels connected to these fault inputs must be configured as asynchronous. The TCC must work in a PWM mode.

##### Fault Filtering

There are three filters available for each input Fault A and Fault B. They are configured by the corresponding Recoverable Fault n Configuration registers (FCTRLA and FCTRLB). The three filters can either be used independently or in any combination.

**Input Filtering** By default, the event detection is asynchronous. When the event occurs, the fault system will immediately and asynchronously perform the selected fault action on the compare channel output, also in device power modes where the clock is not available. To avoid false fault detection on external events (e.g. due to a glitch on an I/O port) a digital filter can be enabled and configured by the Fault n Filter Value bits in the Fault n Configuration registers (FCTRLn.FILTERVAL). If the event width is less than FILTERVAL (in clock cycles), the event will be discarded. A valid event will be delayed by FILTERVAL clock cycles.

**Fault Blanking** This ignores any fault input for a certain time just after a selected waveform output edge. This can be used to prevent false fault triggering due to signal bouncing, as shown in the figure below. Blanking can be enabled by writing an edge triggering configuration to the Fault n Blanking Mode bits in the Recoverable Fault n Configuration register (FCTRLn.BLANK). The desired duration of the blanking must be written to the Fault n Blanking Time bits (FCTRLn.BLANKVAL). The blanking time  $t_b$  is calculated by

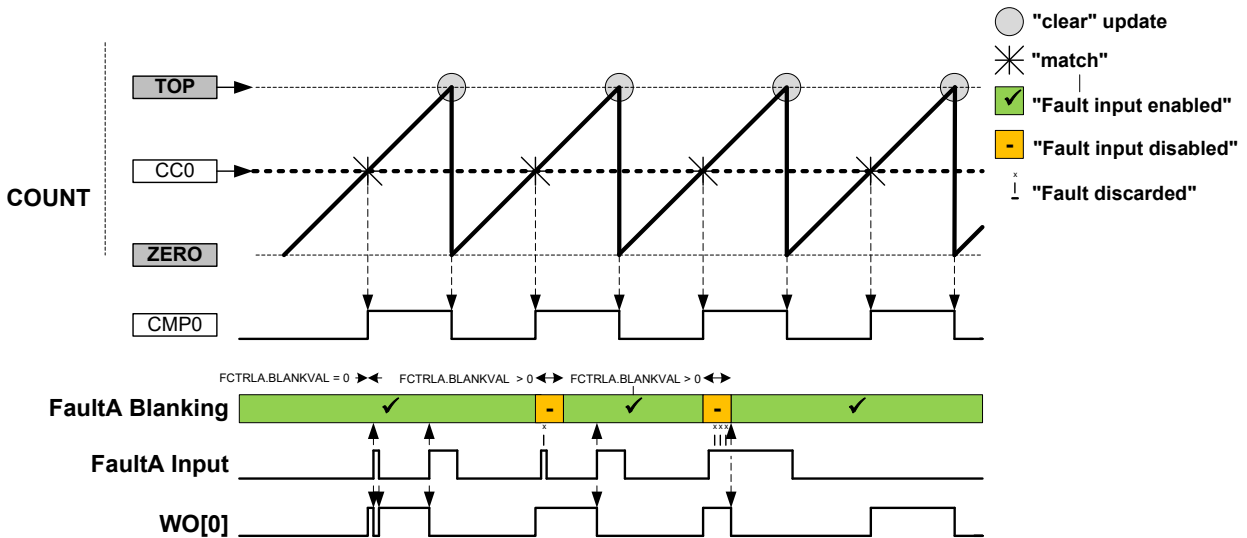
$$t_b = \frac{1 + \text{BLANKVAL}}{f_{\text{GCLK\_TCCx\_PRESC}}}$$

Here,  $f_{\text{GCLK\_TCCx\_PRESC}}$  is the frequency of the prescaled peripheral clock frequency  $f_{\text{GCLK\_TCCx}}$ .

The prescaler is enabled by writing '1' to the Fault n Blanking Prescaler bit (FCTRLn.BLANKPRESC). When disabled,  $f_{\text{GCLK\_TCCx\_PRESC}} = f_{\text{GCLK\_TCCx}}$ . When enabled,  $f_{\text{GCLK\_TCCx\_PRESC}} = f_{\text{GCLK\_TCCx}}/64$ .

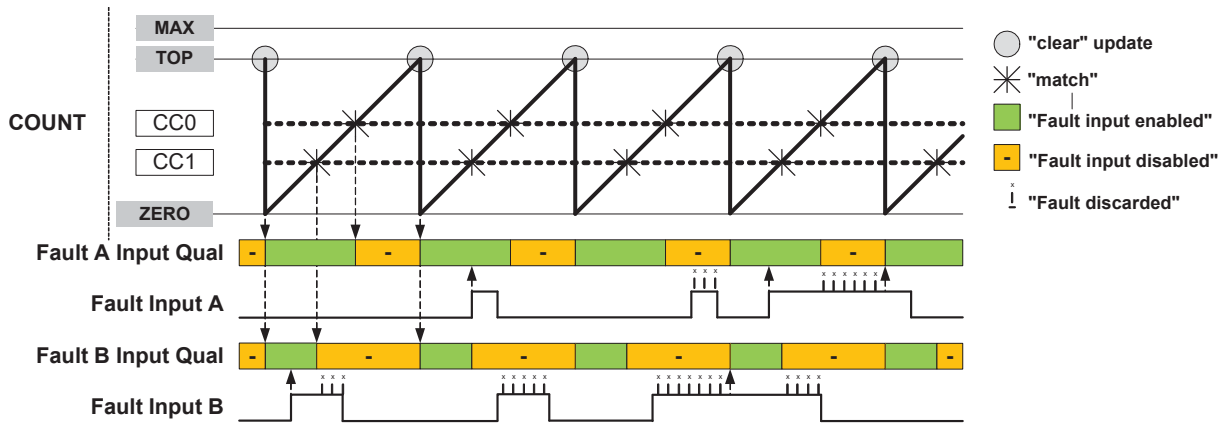
The maximum blanking time (FCTRLn.BLANKVAL=255) at  $f_{GCLK\_TCCx}=96\text{MHz}$  is  $2.67\mu\text{s}$  (no prescaler) or  $170\mu\text{s}$  (prescaling). For  $f_{GCLK\_TCCx}=1\text{MHz}$ , the maximum blanking time is either  $170\mu\text{s}$  (no prescaling) or  $10.9\text{ms}$  (prescaling enabled).

Figure 45-22. Fault Blanking in RAMP1 Operation with Inverted Polarity

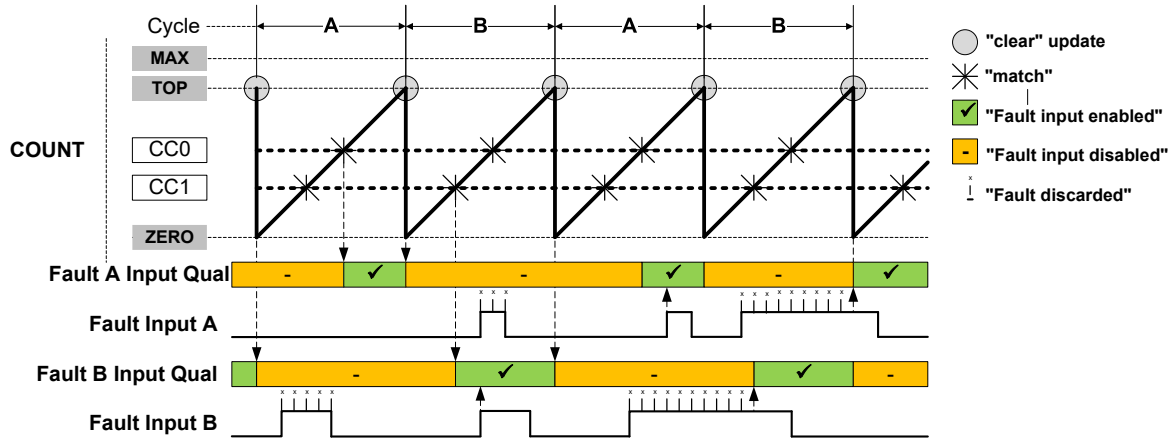


**Fault Qualification** This is enabled by writing a '1' to the Fault n Qualification bit in the Recoverable Fault n Configuration register (FCTRLn.QUAL). When the recoverable fault qualification is enabled (FCTRLn.QUAL=1), the fault input is disabled all the time the corresponding channel output has an inactive level, as shown in the figures below.

Figure 45-23. Fault Qualification in RAMP1 Operation



**Figure 45-24.** Fault Qualification in RAMP2 Operation with Inverted Polarity

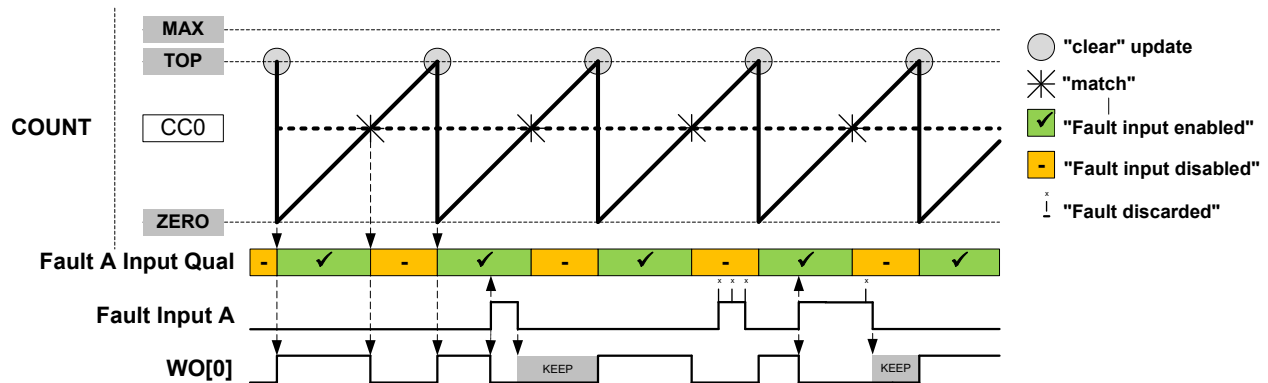


**Fault Actions**

Different fault actions can be configured individually for Fault A and Fault B. Most fault actions are not mutually exclusive; hence two or more actions can be enabled at the same time to achieve a result that is a combination of fault actions.

**Keep Action** This is enabled by writing the Fault n Keeper bit in the Recoverable Fault n Configuration register (FCTRLn.KEEP) to '1'. When enabled, the corresponding channel output will be clamped to zero as long as the fault condition is present. The clamp will be released on the start of the first cycle after the fault condition is no longer present, see next Figure.

**Figure 45-25.** Waveform Generation with Fault Qualification and Keep Action



**Restart Action** This is enabled by writing the Fault n Restart bit in Recoverable Fault n Configuration register (FCTRLn.RESTART) to '1'. When enabled, the timer/counter will be restarted as soon as the corresponding fault condition is present. The ongoing cycle is stopped and the timer/counter starts a new cycle, see the following figure. In Ramp 1 mode, when the new cycle starts, the compare outputs will be clamped to inactive level as long as the fault condition is present.

**Note:** For RAMP2 operation, when a new timer/counter cycle starts the cycle index will change automatically, see the following figure. Fault A and Fault B are qualified only during the cycle A and cycle B respectively: Fault A is disabled during cycle B, and Fault B is disabled during cycle A.

Figure 45-26. Waveform Generation in RAMP1 mode with Restart Action

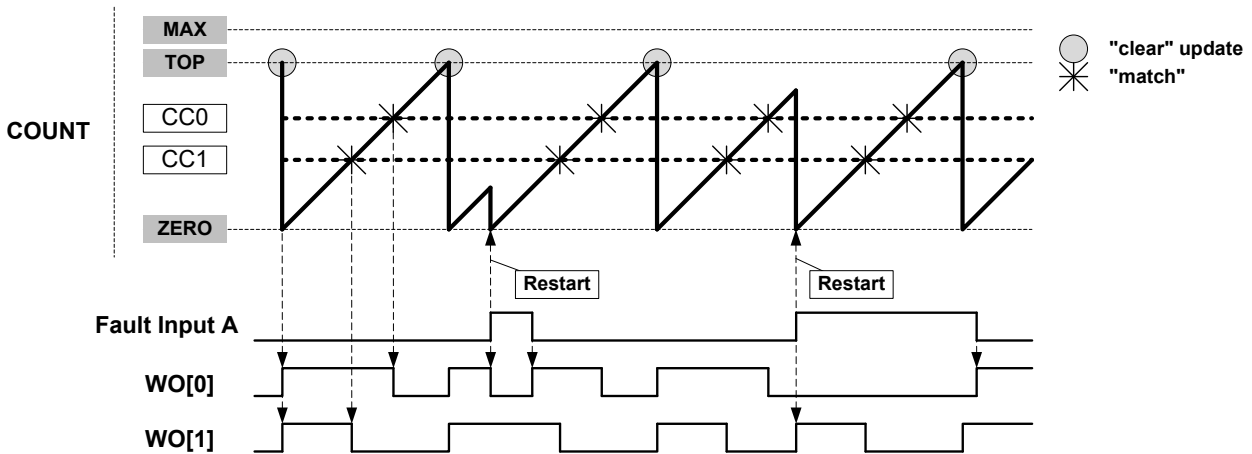
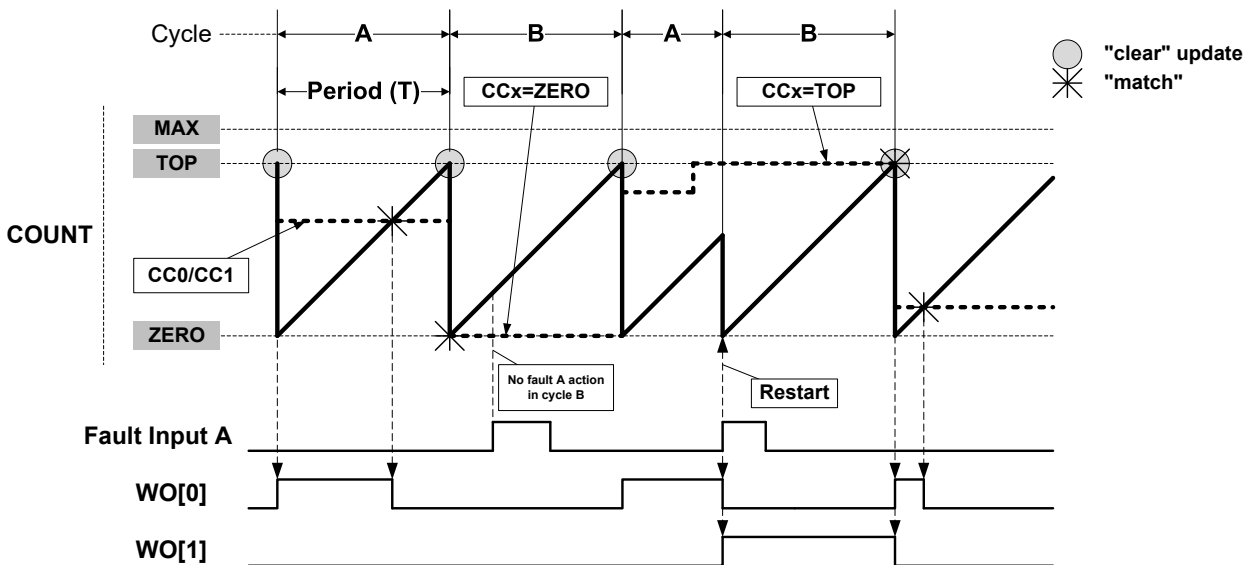


Figure 45-27. Waveform Generation in RAMP2 mode with Restart Action



**Capture Action** Several capture actions can be selected by writing the Fault n Capture Action bits in the Fault n Control register (FCTRLn.CAPTURE). When one of the capture operations is selected, the counter value is captured when the fault occurs. These capture operations are available:

- CAPT - the equivalent to a standard capture operation, for further details refer to [45.6.2.7. Capture Operations](#)
- CAPTMIN - gets the minimum time stamped value: on each new local minimum captured value, an event or interrupt is issued.
- CAPTMAX - gets the maximum time stamped value: on each new local maximum captured value, an event or interrupt (IT) is issued, see the figure, *Capture Action "CAPTMAX"*.
- LOCMIN - notifies by event or interrupt when a local minimum captured value is detected.
- LOCMAX - notifies by event or interrupt when a local maximum captured value is detected.
- DERIV0 - notifies by event or interrupt when a local extreme captured value is detected, see the figure, *Capture Action "DERIV0"*.

*Ccx Content:*

In CAPTMIN and CAPTMAX operations, CCx keeps the respective extremum captured values, see *Capture Action "CAPTMAX"*. In LOCMIN, LOCMAX or DERIV0 operation, CCx follows the counter value at fault time, see *Capture Action "DERIV0"*.

Before enabling CAPTMIN or CAPTMAX mode of capture, the user must initialize the corresponding CCx register value to a value different from zero (for CAPTMIN) top (for CAPTMAX). If the CCx register initial value is zero (for CAPTMIN) top (for CAPTMAX), no captures will be performed using the corresponding channel.

*MCx Behaviour:*

In LOCMIN and LOCMAX operation, capture is performed on each capture event. The MCx interrupt flag is set only when the captured value is above or equal (for LOCMIN) or below or equal (for LOCMAX) to the previous captured value. So interrupt flag is set when a new relative local Minimum (for CAPTMIN) or Maximum (for CAPTMAX) value has been detected. DERIVO is equivalent to an OR function of (LOCMIN, LOCMAX).

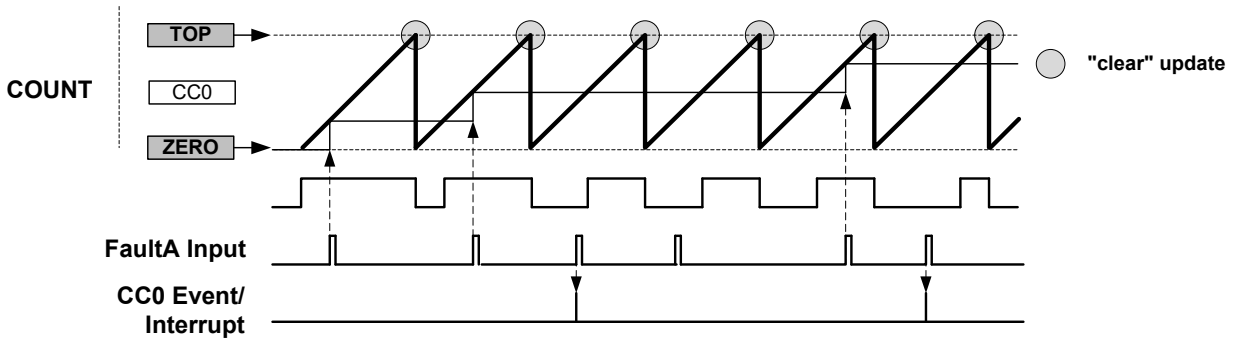
In CAPT operation, capture is performed on each capture event. The MCx interrupt flag is set on each new capture.

In CAPTMIN and CAPTMAX operation, capture is performed only when on capture event time, the counter value is lower (for CAPTMIN) or higher (for CAPMAX) than the last captured value. The MCx interrupt flag is set only when on capture event time, the counter value is higher or equal (for CAPTMIN) or lower or equal (for CAPTMAX) to the value captured on the previous event. So interrupt flag is set when a new absolute local Minimum (for CAPTMIN) or Maximum (for CAPTMAX) value has been detected.

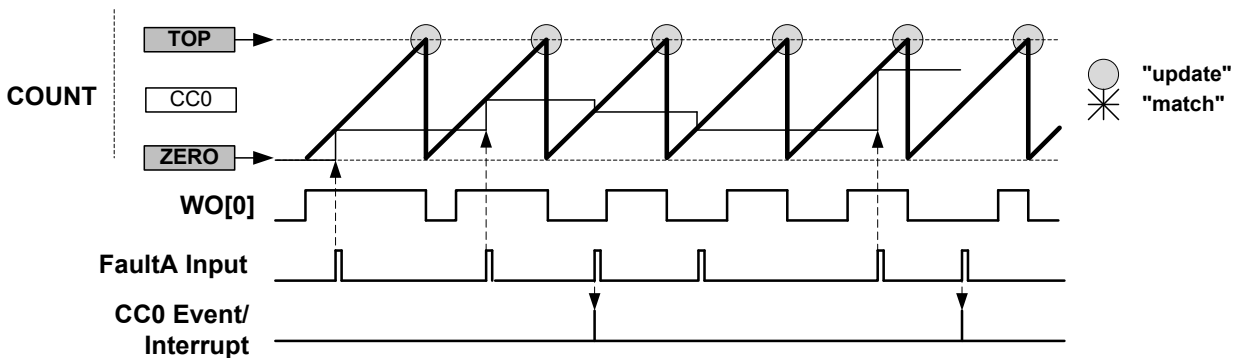
*Interrupt Generation*

In CAPT mode, an interrupt is generated on each filtered Fault n and each dedicated CCx channel capture counter value. In other modes, an interrupt is only generated on an extreme captured value.

**Figure 45-28. Capture Action "CAPTMAX"**



**Figure 45-29. Capture Action "DERIVO"**



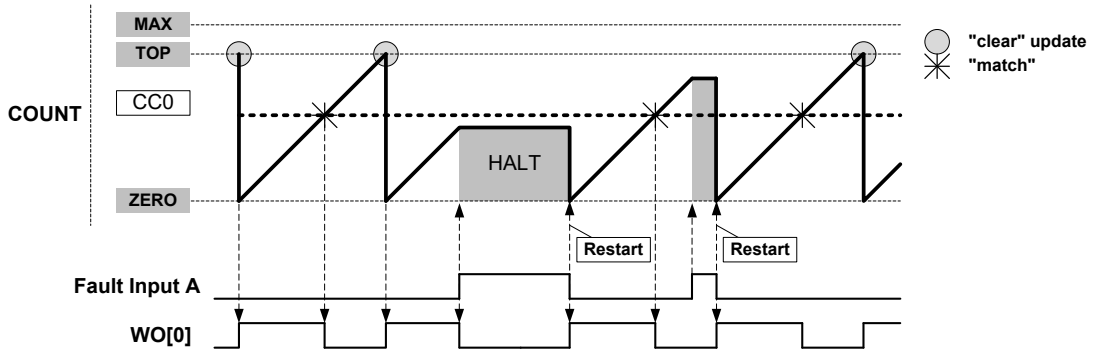
**Hardware Halt Action** This is configured by writing 0x1 to the Fault n Halt mode bits in the Recoverable Fault n Configuration register (FCTRLn.HALT). When enabled, the timer/counter is halted and the cycle is extended as long as the corresponding fault is present.

The next figure ('Waveform Generation with Halt and Restart Actions') shows an example where both restart action and hardware halt action are enabled for Fault A. The compare channel 0 output is clamped to inactive level as long as the timer/counter is halted. The timer/counter resumes the counting operation as soon as the fault condition is no longer present. As the restart action is enabled in this example, the timer/counter is restarted after the fault condition is no longer present.

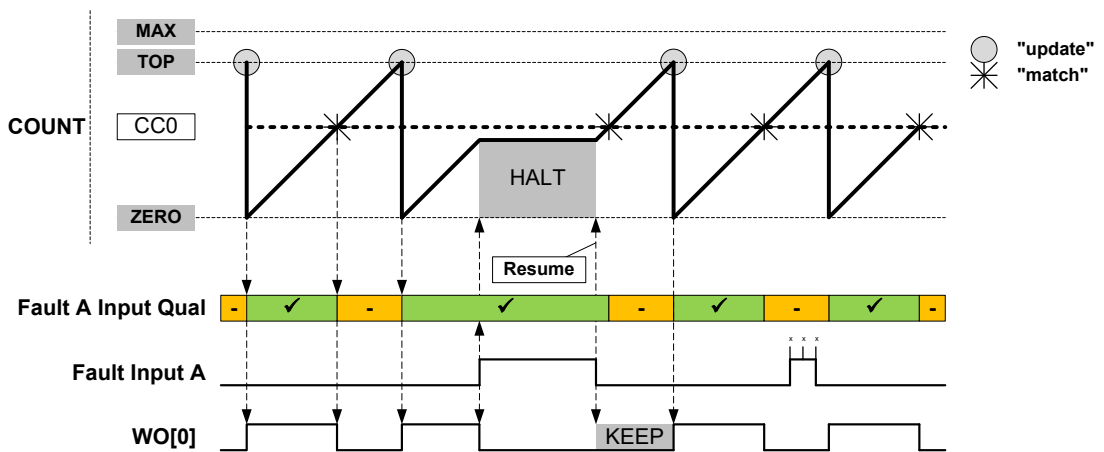
The figure after that ('Waveform Generation with Fault Qualification, Halt, and Restart Actions') shows a similar example, but with additionally enabled fault qualification. Here, counting is resumed after the fault condition is no longer present.

Note that in RAMP2 and RAMP2A operations, when a new timer/counter cycle starts, the cycle index will automatically change.

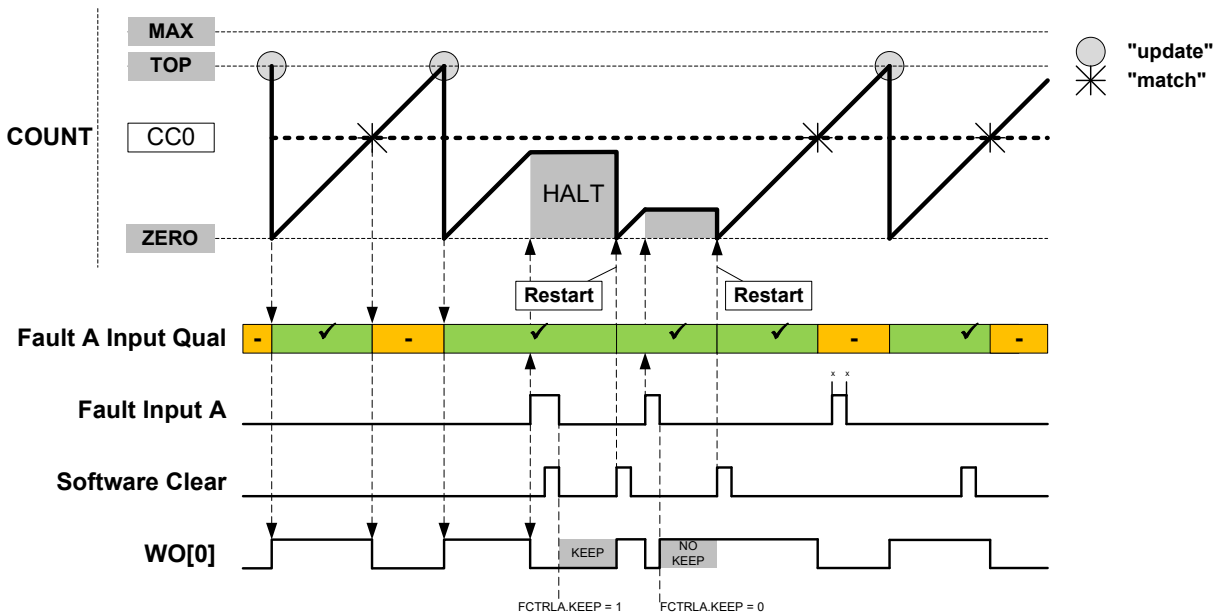
**Figure 45-30. Waveform Generation with Halt and Restart Actions**



**Figure 45-31. Waveform Generation with Fault Qualification, Halt, and Restart Actions**



**Software Halt Action** This is configured by writing 0x2 to the Fault n Halt mode bits in the Recoverable Fault n configuration register (FCTRLn.HALT). Software halt action is similar to hardware halt action, but in order to restart the timer/counter, the corresponding fault condition must not be present anymore, and the corresponding FAULT n bit in the STATUS register must be cleared by software.

**Figure 45-32.** Waveform Generation with Software Halt, Fault Qualification, Keep and Restart Actions

#### 45.6.3.6 Non-Recoverable Faults

The non-recoverable fault action will force all the compare outputs to a pre-defined level programmed into the Driver Control register (DRVCTRL.NRE and DRVCTRL.NRV). The non-recoverable fault input (EV0 and EV1) actions are enabled in Event Control register (EVCTRL.EVACT0 and EVCTRL.EVACT1).

To avoid false fault detection on external events (e.g. a glitch on an I/O port) a digital filter can be enabled using Non-Recoverable Fault Input x Filter Value bits in the Driver Control register (DRVCTRL.FILTERVALn). Therefore, the event detection is synchronous, and event action is delayed by the selected digital filter value clock cycles.

When the Fault Detection on Debug Break Detection bit in Debug Control register (DGBCTRL.FDDBD) is written to '1', a non-recoverable Debug Faults State and an interrupt (DFS) is generated when the system goes in debug operation.

In RAMP2, RAMP2A, or DSBOTH operation, when the Lock Update bit in the Control B register is set by writing CTRLBSET.LUPD=1 and the ramp index or counter direction changes, a non-recoverable Update Fault State and the respective interrupt (UFS) are generated.

#### 45.6.3.7 Time-Stamp Capture on Events or I/Os

This feature is enabled when the Capture Time Stamp (STAMP) Event Action in Event Control register (EVCTRL.EVACT) is selected. The counter TOP value must be smaller than MAX.

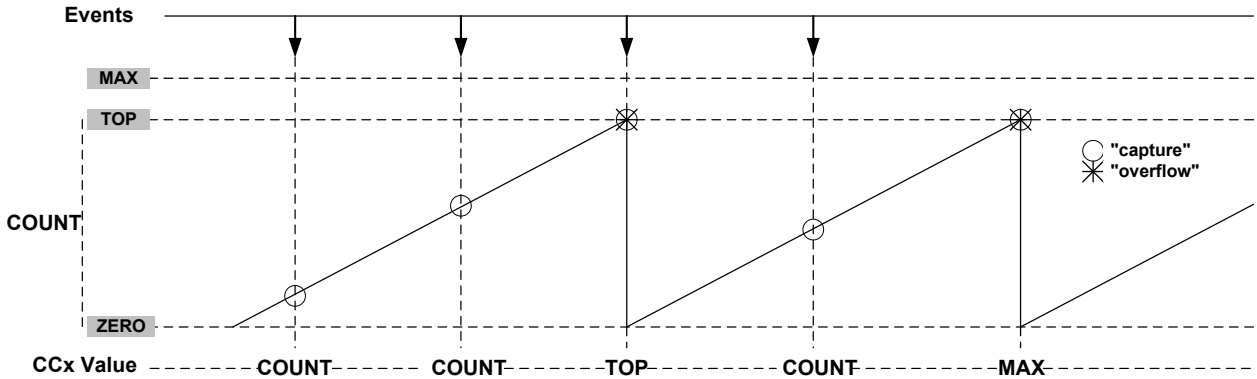
When a capture event is detected from the Event System or the I/O pin, the COUNT value is copied into the corresponding Channel x Compare/Capture Value (CCx) register. In case of an overflow, the MAX value is copied into the corresponding CCx register.

When a valid captured value is present in the capture channel register, the corresponding Capture Channel x Interrupt Flag (INTFLAG.MCx) is set.

The timer/counter can detect capture overflow of the input capture channels: When a new capture event is detected while the Capture Channel interrupt flag (INTFLAG.MCx) is still set, the new time-stamp will not be stored and INTFLAG.ERR will be set.



Figure 45-33. Time-Stamp



### 45.6.3.8 Waveform Extension

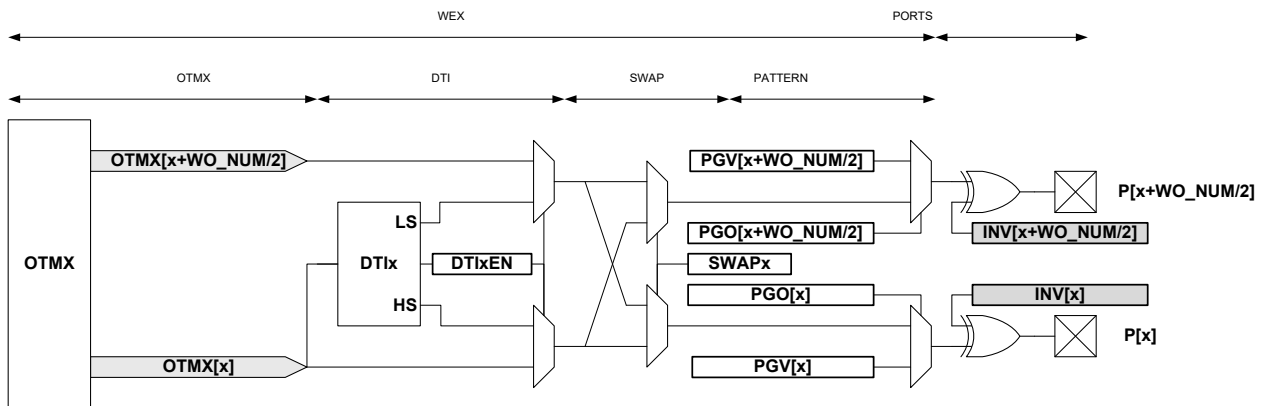
The following figure shows a schematic diagram of actions of the four optional units that follow the recoverable fault stage on a port pin pair: Output Matrix (OTMX), Dead-Time Insertion (DTI), SWAP and Pattern Generation. The DTI and SWAP units can be seen as a four port pair slices:

- Slice 0 DTI0 / SWAP0 acting on port pins (WO[0], WO[WO\_NUM/2 +0])
- Slice 1 DTI1 / SWAP1 acting on port pins (WO[1], WO[WO\_NUM/2 +1])

And generally:

- Slice n DTIx / SWAPx acting on port pins (WO[x], WO[WO\_NUM/2 +x])

Figure 45-34. Waveform Extension Stage Details



The **output matrix (OTMX)** unit distributes compare channels, according to the selectable configurations in the following table.

Table 45-5. Output Matrix Channel Pin Routing Configuration

Value	OTMX[7]	OTMX[6]	OTMX[5]	OTMX[4]	OTMX[3]	OTMX[2]	OTMX[1]	OTMX[0]
0x0	CC1	CC0	CC5	CC4	CC3	CC2	CC1	CC0
0x1	CC1	CC0	CC2	CC1	CC0	CC2	CC1	CC0
0x2	CC0	CC0	CC0	CC0	CC0	CC0	CC0	CC0
0x3	CC1	CC1	CC1	CC1	CC1	CC1	CC1	CC0

- Configuration 0x0 is the default configuration. The channel location is the default one and channels are distributed on outputs modulo the number of channels. Channel 0 is routed to the Output matrix output OTMX[0], and Channel 1 to OTMX[1]. If there are more outputs than channels, then channel 0 is duplicated to the Output matrix output OTMX[CC\_NUM], channel 1 to OTMX[CC\_NUM+1] and so on.

- Configuration 0x1 distributes the channels on output modulo half the number of channels. This assigns twice the number of output locations to the lower channels than the default configuration. This can be used, for example, to control the four transistors of a full bridge using only two compare channels. Using pattern generation, some of these four outputs can be overwritten by a constant level, enabling flexible drive of a full bridge in all quadrant configurations.
- Configuration 0x2 distributes compare channel 0 (CC0) to all port pins. With pattern generation, this configuration can control a stepper motor.
- Configuration 0x3 distributes the compare channel CC0 to the first output, and the channel CC1 to all other outputs. Together with pattern generation and the fault extension, this configuration can control up to seven LED strings, with a boost stage.

The table below is an example showing four compare channels on four outputs.

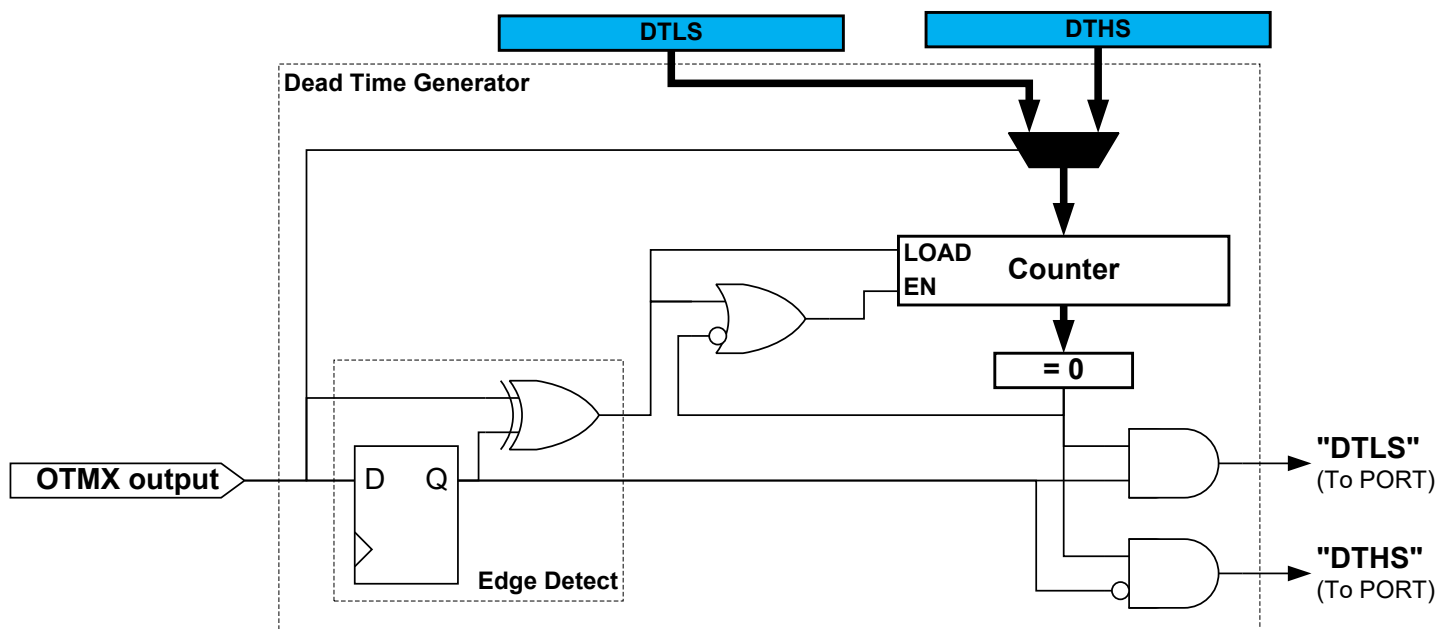
**Table 45-6.** Four Compare Channels on Four Outputs

Value	OTMX[3]	OTMX[2]	OTMX[1]	OTMX[0]
0x0	CC3	CC2	CC1	CC0
0x1	CC1	CC0	CC1	CC0
0x2	CC0	CC0	CC0	CC0
0x3	CC1	CC1	CC1	CC0

**The dead-time insertion (DTI)** unit generates OFF time with the non-inverted low side (LS) and inverted high side (HS) of the wave generator output forced at low level. This OFF time is called dead time. Dead-time insertion ensures that the LS and HS will never switch simultaneously.

The DTI stage consists of four equal dead-time insertion generators; one for each of the first four compare channels. The following figure shows the block diagram of one DTI generator. The four channels have a common register which controls the dead time, which is independent of high side and low side setting.

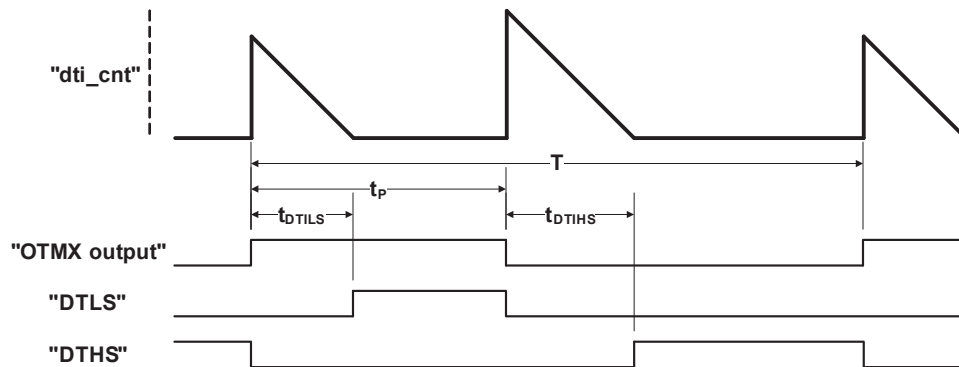
**Figure 45-35.** Dead-Time Generator Block Diagram



As shown in the following figure, the 8-bit dead-time counter is decremented by one for each peripheral clock cycle until it reaches zero. A non-zero counter value will force both the low side

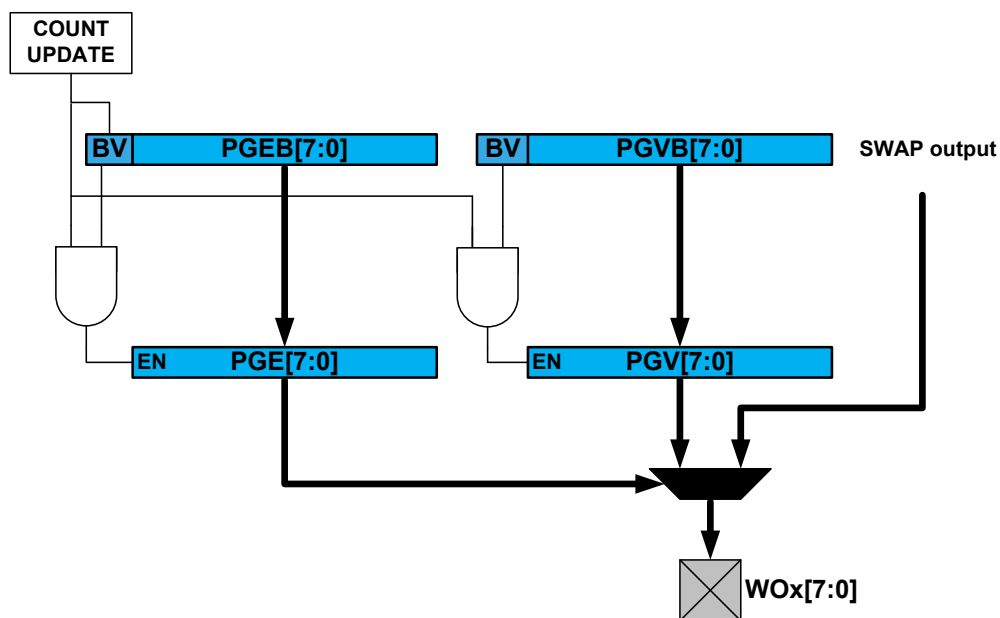
and high side outputs into their OFF state. When the output matrix (OTMX) output changes, the dead-time counter is reloaded according to the edge of the input. When the output changes from low to high (positive edge) it initiates a counter reload of the DTLS register. When the output changes from high to low (negative edge) it reloads the DTHS register.

**Figure 45-36.** Dead-Time Generator Timing Diagram



**The pattern generator unit** produces a synchronized bit pattern across the port pins it is connected to. The pattern generation features are primarily intended for handling the commutation sequence in brushless DC motors (BLDC), stepper motors, and full bridge control. For more information, refer to the following figure.

**Figure 45-37.** Pattern Generator Block Diagram



As with other double-buffered timer/counter registers, the register update is synchronized to the UPDATE condition set by the timer/counter waveform generation operation. If synchronization is not required by the application, the software can simply access directly the PATT.PGE, PATT.PGV bits registers.

#### 45.6.4 Host/Client Operation

Two or more TCC instances sharing the same GCLK\_TCCx clock, can be linked to provide more synchronized CC channels. The operation is enabled by setting the Host Synchronization bit in

Control A register (CTRLA.MSYNC) in the Client instance. When the bit is set, the Client TCC instance will synchronize the CC channels to the Host counter.

## 45.6.5 DMA, Interrupts, and Events

**Table 45-7.** Module Requests for TCC

Condition	Interrupt request	Event output	Event input	DMA request	DMA request is cleared
Overflow / Underflow	Yes	Yes		Yes <sup>(1)</sup>	On DMA acknowledge
Channel Compare Match or Capture	Yes	Yes	Yes <sup>(2)</sup>	Yes <sup>(3)</sup>	For circular buffering: on DMA acknowledge For capture channel: when CCx register is read
Retrigger	Yes	Yes			
Count	Yes	Yes			
Capture Overflow Error	Yes				
Debug Fault State	Yes				
Recoverable Faults	Yes				
Non-Recoverable Faults	Yes				
TCCx Event 0 input			Yes <sup>(4)</sup>		
TCCx Event 1 input			Yes <sup>(5)</sup>		

Notes:

1. DMA request set on Overflow, Underflow or Re-trigger conditions.
2. Can perform capture or generate recoverable fault on an event input.
3. In Capture or Circular modes.
4. On event input, either action can be executed:
  - re-trigger counter
  - control counter direction
  - stop the counter
  - decrement the counter
  - perform period and pulse width capture
  - generate non-recoverable fault
5. On event input, either action can be executed:
  - re-trigger counter
  - increment or decrement counter depending on direction
  - start the counter
  - increment or decrement counter based on direction
  - increment counter regardless of direction
  - generate non-recoverable fault

### 45.6.5.1 DMA Operation

The TCC can generate the following DMA requests:

<b>Counter overflow (OVF)</b>	If the One-shot Trigger mode in the control A register (CTRLA.DMAOS) is written to '0', the TCC generates a DMA request on each cycle when an update condition (Overflow, Underflow or Re-trigger) is detected. When an update condition (Overflow, Underflow or Re-trigger) is detected while CTRLA.DMAOS=1, the TCC generates a DMA trigger on the cycle following the DMA One-Shot Command written to the Control B register (CTRLBSET.CMD=DMAOS).
-------------------------------	---

**Note:** Counter Overflow (OVF) DMA Trigger in DMA One-Shot Trigger Mode (CTRLA.DMAOS = 1) is not functional for Critical RAMP2C and RAMP2CS operation modes.

In both cases, the request is cleared by hardware on DMA acknowledge.

**Channel Match (MCx)** A DMA request is set only on a compare match if CTRLA.DMAOS=0. The request is cleared by hardware on DMA acknowledge.  
When CTRLA.DMAOS=1, the DMA requests are not generated.

**Channel Capture (MCx)** For a capture channel, the request is set when valid data is present in the CCx register, and cleared once the CCx register is read.  
In this operation mode, the CTRLA.DMAOS bit value is ignored.

### DMA Operation with Circular Buffer

When circular buffer operation is enabled, the Buffer registers must be written in a correct order and synchronized to the update times of the timer. The DMA triggers of the TCC provide a way to ensure a safe and correct update of circular buffers.

**Note:** Circular buffer are intended to be used with RAMP2, RAMP2A and DSBOTH operation only.

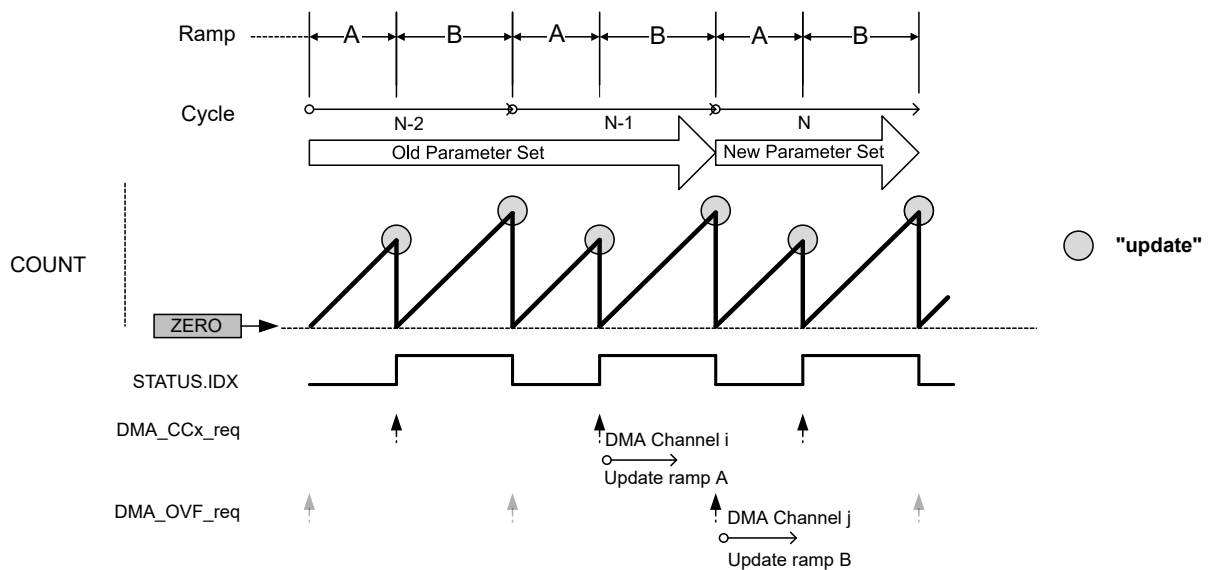
#### DMA Operation with Circular Buffer in RAMP2 and RAMP2A Mode

When a CCx channel is selected as a circular buffer, the related DMA request is not set on a compare match detection, but on start of ramp B.

If at least one circular buffer is enabled, the DMA overflow request is conditioned to the start of ramp A with an effective DMA transfer on previous ramp B (DMA acknowledge).

The update of all circular buffer values for ramp A can be done through a DMA channel triggered on a MC trigger. The update of all circular buffer values for ramp B, can be done through a second DMA channel triggered by the overflow DMA request.

**Figure 45-38.** DMA Triggers in RAMP and RAMP2 Operation Mode and Circular Buffer Enabled



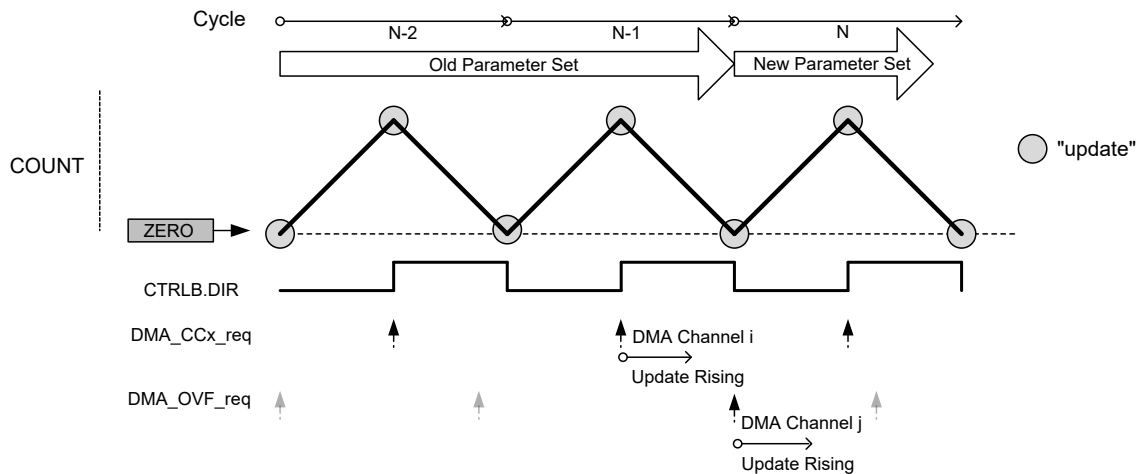
#### DMA Operation with Circular Buffer in DSBOTH Mode

When a CC channel is selected as a circular buffer, the related DMA request is not set on a compare match detection, but on start of down-counting phase.

If at least one circular buffer is enabled, the DMA overflow request is conditioned to the start of up-counting phase with an effective DMA transfer on previous down-counting phase (DMA acknowledge).

When up-counting, all circular buffer values can be updated through a DMA channel triggered by MC trigger. When down-counting, all circular buffer values can be updated through a second DMA channel, triggered by the OVF DMA request.

**Figure 45-39.** DMA Triggers in DSBOOTH Operation Mode and Circular Buffer Enabled



#### 45.6.5.2 Interrupts

The TCC has the following interrupt sources:

- Overflow/Underflow (OVF)
- Retrigger (TRG)
- Count (CNT) - refer also to description of [EVCTRL.CNTSEL](#).
- Capture Overflow Error (ERR)
- Non-Recoverable Update Fault (UFS)
- Debug Fault State (DFS)
- Recoverable Faults (FAULTn)
- Non-recoverable Faults (FAULTx)
- Compare Match or Capture Channels (MCx)

These interrupts are asynchronous wake-up sources. See Sleep Mode Entry and Exit Table in [PM/Sleep Mode Controller](#) section for details.

Each interrupt source has an Interrupt flag associated with it. The Interrupt flag in the Interrupt Flag Status and Clear (INTFLAG) register is set when the Interrupt condition occurs. Each interrupt can be individually enabled by writing a '1' to the corresponding bit in the Interrupt Enable Set (INTENSET) register, and disabled by writing a '1' to the corresponding bit in the Interrupt Enable Clear (INTENCLR) register. The status of enabled interrupts can be read from either INTENSET or INTENCLR.

An interrupt request is generated when the Interrupt flag is set and the corresponding interrupt is enabled. The interrupt request remains active until the Interrupt flag is cleared, the interrupt is disabled, or the TCC is reset. See [45.7.12. INTFLAG](#) for details on how to clear Interrupt flags. The TCC has one common interrupt request line for all the interrupt sources. The user must read the INTFLAG register to determine which Interrupt condition is present.

Note: Interrupts must be globally enabled for interrupt requests to be generated. Refer to [Nested Vector Interrupt Controller](#) for details.

### 45.6.5.3 Events

The TCC can generate the following output events:

- Overflow/Underflow (OVF)
- Trigger (TRG)
- Counter (CNT) For further details, refer to [EVCTRL.CNTSEL](#) description.
- Compare Match or Capture on compare/capture channels: MCx

Writing a '1' ('0') to an Event Output bit in the Event Control Register (EVCTRL.xxEO) enables (disables) the corresponding output event. Refer also to *EVSYS – Event System*.

The TCC can take the following actions on a channel input event (MCx):

- Capture event
- Generate a recoverable or non-recoverable fault

The TCC can take the following actions on counter Event 1 (TCCx EV1):

- Counter re-trigger
  - If a re-trigger event occurs exactly at the time a Channel Compare Match occurs, the next waveform will be corrupted. To avoid this issue, use two channels to store two successive CC register values (n and n+1) and combine the related waveform outputs to provide signal redundancy.
- Counter direction control
- Stop the counter
- Decrement the counter on event
- Period and pulse width capture
- Non-recoverable fault

The TCC can take the following actions on counter Event 0 (TCCx EV0):

- Counter re-trigger
  - If a re-trigger event occurs exactly at the time a Channel Compare Match occurs, the next waveform will be corrupted. To avoid this issue, use two channels to store two successive CC register values (n and n+1) and combine the related waveform outputs to provide signal redundancy.
- Count on event (increment or decrement, depending on counter direction)
- Counter start - start counting on the event rising edge. Further events will not restart the counter; the counter will keep on counting using prescaled GCLK\_TCCx, until it reaches TOP or ZERO, depending on the direction.
- Counter increment on event. This will increment the counter, irrespective of the counter direction.
- Count during active state of an asynchronous event (increment or decrement, depending on counter direction). In this case, the counter will be incremented or decremented on each cycle of the prescaled clock, as long as the event is active.
- Non-recoverable fault

The counter Event Actions are available in the Event Control registers (EVCTRL.EVACT0 and EVCTRL.EVACT1). For further details, refer to [EVCTRL](#).

Writing a '1' ('0') to an Event Input bit in the Event Control register (EVCTRL.MCEIx or EVCTRL.TCEIx) enables (disables) the corresponding action on input event.



**Important:** When TCC input events are used, the respective channel path of the Event System must be configured as an Asynchronous path (EVSYS CHANNELx.PATH = 0x2).

**Note:** When several events are connected to the TCC, the enabled action will apply for each of the incoming events. Refer to *EVSYS – Event System* for details on how to configure the event system.

#### 45.6.6 Sleep Mode Operation

The TCC can be configured to operate in any Sleep mode. To be able to run in standby the RUNSTDBY bit in the Control A register (CTRLA.RUNSTDBY) must be '1'. The MODULE can in any Sleep mode wake-up the device using interrupts or perform actions through the Event System.

#### 45.6.7 Synchronization

Due to asynchronicity between the main clock domain and the peripheral clock domains, some registers need to be synchronized when written or read.

The followings bits are synchronized when written:

- Software Reset and Enable bits in Control A register (CTRLA.SWRST and CTRLA.ENABLE)

The following registers are synchronized when written:

- Control B Clear and Control B Set registers (CTRLBCLR and CTRLBSET)
- Status register (STATUS)
- Pattern and Pattern Buffer registers (PATT and PATTBUF)
- Waveform register (WAVE)
- Count Value register (COUNT)
- Period Value and Period Buffer Value registers (PER and PERBUF)
- Compare/Capture Channel x and Channel x Compare/Capture Buffer Value registers (CCx and CCBUFx)

The following registers are synchronized when read:

- Control B Clear and Control B Set registers (CTRLBCLR and CTRLBSET)
- Count Value register (COUNT): synchronization is done on demand through READSYNC command (CTRLBSET.CMD)
- Pattern and Pattern Buffer registers (PATT and PATTBUF)
- Waveform register (WAVE)
- Period Value and Period Buffer Value registers (PER and PERBUF)
- Compare/Capture Channel x and Channel x Compare/Capture Buffer Value registers (CCx and CCBUFx)

Required write synchronization is denoted by the "Write-Synchronized" property in the register description.

Required read synchronization is denoted by the "Read-Synchronized" property in the register description.



## 45.7 Register Summary

Offset	Name	Bit Pos.	7	6	5	4	3	2	1	0	
0x00	CTRLA	7:0	RESOLUTION[1:0]							ENABLE	SWRST
		15:8	MSYNC	ALOCK	PRESCSYNC[1:0]		RUNSTDBY	PRESCALER[2:0]			
		23:16	DMAOS								
		31:24			CPTEN5	CPTEN4	CPTEN3	CPTEN2	CPTEN1	CPTEN0	
0x04	CTRLBCLR	7:0	CMD[2:0]		IDXCMD[1:0]		ONESHOT	LUPD	DIR		
0x05	CTRLBSET	7:0	CMD[2:0]		IDXCMD[1:0]		ONESHOT	LUPD	DIR		
0x06	Reserved										
0x07											
0x08	SYNCBUSY	7:0	PER	WAVE	PATT	COUNT	STATUS	CTRLB	ENABLE	SWRST	
		15:8			CC5	CC4	CC3	CC2	CC1	CC0	
		23:16									
		31:24									
0x0C	FCTRLA	7:0	RESTART	BLANK[1:0]		QUAL	KEEP		SRC[1:0]		
		15:8	BLANKPRESC	CAPTURE[2:0]		CHSEL[1:0]			HALT[1:0]		
		23:16	BLANKVAL[7:0]								
		31:24								FILTERVAL[3:0]	
0x10	FCTRLB	7:0	RESTART	BLANK[1:0]		QUAL	KEEP		SRC[1:0]		
		15:8	BLANKPRESC	CAPTURE[2:0]		CHSEL[1:0]			HALT[1:0]		
		23:16	BLANKVAL[7:0]								
		31:24								FILTERVAL[3:0]	
0x14	WEXCTRL	7:0							OTMX[1:0]		
		15:8					DTIEN3	DTIEN2	DTIEN1	DTIEN0	
		23:16	DTLS[7:0]								
		31:24	DTHS[7:0]								
0x18	DRVCTRL	7:0	NRE7	NRE6	NRE5	NRE4	NRE3	NRE2	NRE1	NRE0	
		15:8	NRV7	NRV6	NRV5	NRV4	NRV3	NRV2	NRV1	NRV0	
		23:16	INVEN7	INVEN6	INVEN5	INVEN4	INVEN3	INVEN2	INVEN1	INVEN0	
		31:24	FILTERVAL1[3:0]			FILTERVAL0[3:0]					
0x1C	Reserved										
0x1D											
0x1E	DBGCTRL	7:0					FDDBD		DBGRUN		
0x1F	Reserved										
0x20	EVCTRL	7:0	CNTSEL[1:0]		EVACT1[2:0]		EVACT0[2:0]				
		15:8	TCEI1	TCEI0	TCINV1	TCINV0		CNTEO	TRGEO	OVFEO	
		23:16			MCEI5	MCEI4	MCEI3	MCEI2	MCEI1	MCEI0	
		31:24			MCEO5	MCEO4	MCEO3	MCEO2	MCEO1	MCEO0	
0x24	INTENCLR	7:0					ERR	CNT	TRG	OVF	
		15:8	FAULT1	FAULT0	FAULTB	FAULTA	DFS	UFS			
		23:16			MC5	MC4	MC3	MC2	MC1	MC0	
		31:24									
0x28	INTENSET	7:0					ERR	CNT	TRG	OVF	
		15:8	FAULT1	FAULT0	FAULTB	FAULTA	DFS	UFS			
		23:16			MC5	MC4	MC3	MC2	MC1	MC0	
		31:24									
0x2C	INTFLAG	7:0					ERR	CNT	TRG	OVF	
		15:8	FAULT1	FAULT0	FAULTB	FAULTA	DFS	UFS			
		23:16			MC5	MC4	MC3	MC2	MC1	MC0	
		31:24									
0x30	STATUS	7:0	PERBUFV		PATTBUFV	SLAVE	DFS	UFS	IDX	STOP	
		15:8	FAULT1	FAULT0	FAULTB	FAULTA	FAULT1IN	FAULT0IN	FAULTBIN	FAULTAIN	
		23:16			CCBUFV5	CCBUFV4	CCBUFV3	CCBUFV2	CCBUFV1	CCBUFV0	
		31:24			CMP5	CMP4	CMP3	CMP2	CMP1	CMP0	
0x34	COUNT	7:0	COUNT[7:0]								
		15:8	COUNT[15:8]								
		23:16	COUNT[23:16]								
		31:24									

.....continued

Offset	Name	Bit Pos.	7	6	5	4	3	2	1	0
0x38	PATT	7:0	PGE7	PGE6	PGE5	PGE4	PGE3	PGE2	PGE1	PGE0
		15:8	PGV7	PGV6	PGV5	PGV4	PGV3	PGV2	PGV1	PGV0
0x3A ... 0x3B	Reserved									
0x3C	WAVE	7:0	CIPEREN		RAMP[1:0]			WAVEGEN[2:0]		
		15:8					CICCEN3	CICCEN2	CICCEN1	CICCEN0
		23:16			POL5	POL4	POL3	POL2	POL1	POL0
		31:24					SWAP3	SWAP2	SWAP1	SWAP0
0x40	PER	7:0	PER[1:0]		DITHER[5:0]					
		15:8	PER[9:2]							
		23:16	PER[17:10]							
		31:24								
0x44	CC0	7:0	CC[1:0]		DITHER[5:0]					
		15:8	CC[9:2]							
		23:16	CC[17:10]							
		31:24								
0x48	CC1	7:0	CC[1:0]		DITHER[5:0]					
		15:8	CC[9:2]							
		23:16	CC[17:10]							
		31:24								
0x4C	CC2	7:0	CC[1:0]		DITHER[5:0]					
		15:8	CC[9:2]							
		23:16	CC[17:10]							
		31:24								
0x50	CC3	7:0	CC[1:0]		DITHER[5:0]					
		15:8	CC[9:2]							
		23:16	CC[17:10]							
		31:24								
0x54	CC4	7:0	CC[1:0]		DITHER[5:0]					
		15:8	CC[9:2]							
		23:16	CC[17:10]							
		31:24								
0x58	CC5	7:0	CC[1:0]		DITHER[5:0]					
		15:8	CC[9:2]							
		23:16	CC[17:10]							
		31:24								
0x5C ... 0x63	Reserved									
0x64	PATTBUF	7:0	PGEB7	PGEB6	PGEB5	PGEB4	PGEB3	PGEB2	PGEB1	PGEB0
		15:8	PGVB7	PGVB6	PGVB5	PGVB4	PGVB3	PGVB2	PGVB1	PGVB0
0x66 ... 0x6B	Reserved									
0x6C	PERBUF	7:0	PERBUF[1:0]		DITHERBUF[5:0]					
		15:8	PERBUF[9:2]							
		23:16	PERBUF[17:10]							
		31:24								
0x70	CCBUF0	7:0	CCBUF[1:0]		DITHERBUF[5:0]					
		15:8	CCBUF[9:2]							
		23:16	CCBUF[17:10]							
		31:24								
0x74	CCBUF1	7:0	CCBUF[1:0]		DITHERBUF[5:0]					
		15:8	CCBUF[9:2]							
		23:16	CCBUF[17:10]							
		31:24								
0x78	CCBUF2	7:0	CCBUF[1:0]		DITHERBUF[5:0]					
		15:8	CCBUF[9:2]							
		23:16	CCBUF[17:10]							
		31:24								

.....continued

Offset	Name	Bit Pos.	7	6	5	4	3	2	1	0	
0x7C	CCBUF3	7:0	CCBUF[1:0]			DITHERBUF[5:0]					
		15:8	CCBUF[9:2]								
		23:16	CCBUF[17:10]								
		31:24									
0x80	CCBUF4	7:0	CCBUF[1:0]			DITHERBUF[5:0]					
		15:8	CCBUF[9:2]								
		23:16	CCBUF[17:10]								
		31:24									
0x84	CCBUF5	7:0	CCBUF[1:0]			DITHERBUF[5:0]					
		15:8	CCBUF[9:2]								
		23:16	CCBUF[17:10]								
		31:24									

### 45.7.1 Control A

**Name:** CTRLA  
**Offset:** 0x00  
**Reset:** 0x00000000  
**Property:** PAC Write-Protection, Write-Synchronized Bits, Enable-Protected

Bit	31	30	29	28	27	26	25	24
			CPTEN5	CPTEN4	CPTEN3	CPTEN2	CPTEN1	CPTEN0
Access			R/W	R/W	R/W	R/W	R/W	R/W
Reset			0	0	0	0	0	0
Bit	23	22	21	20	19	18	17	16
	DMAOS							
Access	R/W							
Reset	0							
Bit	15	14	13	12	11	10	9	8
	MSYNC	ALOCK	PRESCSYNC[1:0]		RUNSTDBY	PRESCALER[2:0]		
Access	R/W	R/W	R/W	R/W	R/W	R/W	R/W	R/W
Reset	0	0	0	0	0	0	0	0
Bit	7	6	5	4	3	2	1	0
		RESOLUTION[1:0]					ENABLE	SWRST
Access		R/W	R/W				R/W	R/W
Reset		0	0				0	0

**Bits 24, 25, 26, 27, 28, 29 – CPTENx** Capture Channel x Enable, x = 0..5  
 These bits are used to select the capture or compare operation on channel x.  
 Writing a '1' to CPTENx enables capture on channel x.  
 Writing a '0' to CPTENx disables capture on channel x.

**Bit 23 – DMAOS** DMA One-Shot Trigger Mode  
 This bit enables the DMA One-shot Trigger Mode.  
 Writing a '1' to this bit will generate a DMA trigger on TCC cycle following a TCC\_CTRLBSET\_CMD\_DMAOS command.  
 Writing a '0' to this bit will generate DMA triggers on each TCC cycle.  
 This bit is not synchronized.

**Bit 15 – MSYNC** Host Synchronization (only for TCC Client instance)  
 This bit must be set if the TCC counting operation must be synchronized on its Host TCC.  
 This bit is not synchronized.

Value	Description
0	The TCC controls its own counter.
1	The counter is controlled by its Host TCC.

**Bit 14 – ALOCK** Auto Lock  
 This bit is not synchronized.

Value	Description
0	The Lock Update bit in the Control B register (CTRLB.LUPD) is not affected by overflow/underflow, and re-trigger events
1	CTRLB.LUPD is set to '1' on each overflow/underflow or re-trigger event.

**Bits 13:12 – PRESCSYNC[1:0]** Prescaler and Counter Synchronization

These bits select if on re-trigger event, the Counter is cleared or reloaded on either the next GCLK\_TCCx clock, or on the next prescaled GCLK\_TCCx clock. It is also possible to reset the prescaler on re-trigger event.

These bits are not synchronized.

Value	Name	Description	
		Counter Reloaded	Prescaler
0x0	GCLK	Reload or reset Counter on next GCLK	-
0x1	PRESC	Reload or reset Counter on next prescaler clock	-
0x2	RESYNC	Reload or reset Counter on next GCLK	Reset prescaler counter
0x3	Reserved		

**Bit 11 – RUNSTDBY** Run in Standby

This bit is used to keep the TCC running in Standby mode.

This bit is not synchronized.

Value	Description
0	The TCC is halted in standby.
1	The TCC continues to run in standby.

**Bits 10:8 – PRESCALER[2:0]** Prescaler

These bits select the Counter prescaler factor.

These bits are not synchronized.

Value	Name	Description
0x0	DIV1	Prescaler: GCLK_TCCx
0x1	DIV2	Prescaler: GCLK_TCCx/2
0x2	DIV4	Prescaler: GCLK_TCCx/4
0x3	DIV8	Prescaler: GCLK_TCCx/8
0x4	DIV16	Prescaler: GCLK_TCCx/16
0x5	DIV64	Prescaler: GCLK_TCCx/64
0x6	DIV256	Prescaler: GCLK_TCCx/256
0x7	DIV1024	Prescaler: GCLK_TCCx/1024

**Bits 6:5 – RESOLUTION[1:0]** Dithering Resolution

These bits increase the TCC resolution by enabling the dithering options.

These bits are not synchronized.

**Table 45-8.** Dithering

Value	Name	Description
0x0	NONE	The dithering is disabled.
0x1	DITH4	Dithering is done every 16 PWM frames. PER[3:0] and CCx[3:0] contain dithering pattern selection.
0x2	DITH5	Dithering is done every 32 PWM frames. PER[4:0] and CCx[4:0] contain dithering pattern selection.
0x3	DITH6	Dithering is done every 64 PWM frames. PER[5:0] and CCx[5:0] contain dithering pattern selection.

**Bit 1 – ENABLE** Enable

Due to synchronization there is delay from writing CTRLA.ENABLE until the peripheral is enabled/disabled. The value written to CTRLA.ENABLE will read back immediately and the ENABLE bit in the SYNCBUSY register (SYNCBUSY.ENABLE) will be set. SYNCBUSY.ENABLE will be cleared when the operation is complete.

Value	Description
0	The peripheral is disabled.
1	The peripheral is enabled.

**Bit 0 – SWRST** Software Reset

Writing a '0' to this bit has no effect.

Writing a '1' to this bit resets all registers in the TCC (except DBGCTRL) to their initial state, and the TCC will be disabled.

Writing a '1' to CTRLA.SWRST will always take precedence; all other writes in the same write-operation will be discarded.

Due to synchronization there is a delay from writing CTRLA.SWRST until the reset is complete. CTRLA.SWRST and SYNCBUSY.SWRST will both be cleared when the reset is complete.

**Notes:**

1. When the CTRLA.SWRST is written, the user must poll the SYNCBUSY.SWRST bit to know when the reset operation is complete.
2. During a SWRST, access to registers/bits without the SWRST are disallowed until the SYNCBUSY.SWRST is cleared by hardware.

Value	Description
0	There is no Reset operation ongoing.
1	The Reset operation is ongoing.

## 45.7.2 Control B Clear

**Name:** CTRLBCLR  
**Offset:** 0x04  
**Reset:** 0x00  
**Property:** PAC Write-Protection, Write-Synchronized, Read-Synchronized

**Note:** This register is write-synchronized: SYNCBUSY.CTRLB must be checked to ensure the CTRLBCLR register synchronization is complete.

This register allows the user to change this register without doing a read-modify-write operation. Changes in this register will also be reflected in the Control B Set (CTRLBSET) register.

Bit	7	6	5	4	3	2	1	0
	CMD[2:0]			IDXCMD[1:0]		ONESHOT	LUPD	DIR
Access	R/W	R/W	R/W	R/W	R/W	R/W	R/W	R/W
Reset	0	0	0	0	0	0	0	0

### Bits 7:5 – CMD[2:0] TCC Command

Writing a '0' to these bits has no effect.

Writing a '1' to any of these bits will clear the pending command.

### Bits 4:3 – IDXCMD[1:0] Ramp Index Command

These bits can be used to force cycle A and cycle B changes in RAMP2 and RAMP2A operation.

On timer/counter update condition, the command is executed, the IDX flag in STATUS register is updated and the IDXCMD command is cleared.

Writing zero to these bits has no effect.

Writing a '1' to any of these bits will clear the pending command.

Value	Name	Description
0x0	DISABLE	DISABLE Command disabled: IDX toggles between cycles A and B
0x1	SET	Set IDX: cycle B will be forced in the next cycle
0x2	CLEAR	Clear IDX: cycle A will be forced in next cycle
0x3	HOLD	Hold IDX: the next cycle will be the same as the current cycle.

### Bit 2 – ONESHOT One-Shot

This bit controls one-shot operation of the TCC. When one-shot operation is enabled, the TCC will stop counting on the next overflow/underflow condition or on a stop command.

Writing a '0' to this bit has no effect

Writing a '1' to this bit will disable the one-shot operation.

Value	Description
0	The TCC will update the counter value on overflow/underflow condition and continue operation.
1	The TCC will stop counting on the next underflow/overflow condition.

### Bit 1 – LUPD Lock Update

This bit controls the update operation of the TCC buffered registers.

When CTRLB.LUPD is cleared, the hardware UPDATE registers with value from their buffered registers is enabled.

This bit has no effect when input capture operation is enabled.

Writing a '0' to this bit has no effect.

Writing a '1' to this bit will enable the registers updates on hardware UPDATE condition.

Value	Description
0	The CCBx, PERB, PGVB, and PGEB buffer registers values <i>are</i> copied into the corresponding CCx, PER, PGV, and PGE registers on hardware update condition.
1	The CCBx, PERB, PGVB, and PGEB buffer registers values are <i>not</i> copied into the corresponding CCx, PER, PGV, and PGE registers on hardware update condition.

**Bit 0 – DIR** Counter Direction

This bit is used to change the direction of the counter.

Writing a '0' to this bit has no effect

Writing a '1' to this bit will clear the bit and make the counter count up.

Value	Description
0	The timer/counter is counting up (incrementing).
1	The timer/counter is counting down (decrementing).



### 45.7.3 Control B Set

**Name:** CTRLBSET  
**Offset:** 0x05  
**Reset:** 0x00  
**Property:** PAC Write-Protection, Write-Synchronized, Read-Synchronized

**Note:** This register is write-synchronized: SYNCBUSY.CTRLB must be checked to ensure the CTRLBCLR register synchronization is complete.

This register allows the user to change this register without doing a read-modify-write operation. Changes in this register will also be reflected in the Control B Set (CTRLBCLR) register.

Bit	7	6	5	4	3	2	1	0
	CMD[2:0]			IDXCMD[1:0]		ONESHOT	LUPD	DIR
Access	R/W	R/W	R/W	R/W	R/W	R/W	R/W	R/W
Reset	0	0	0	0	0	0	0	0

#### Bits 7:5 – CMD[2:0] TCC Command

These bits can be used for software control of re-triggering and stop commands of the TCC. When a command has been executed, the CMD bit field will be read back as zero. The commands are executed on the next prescaled GCLK\_TCCx clock cycle.

Writing zero to this bit group has no effect

Writing a value different from 0x0 to this bit field will issue a command for execution.



**Important:** This command requires synchronization before being executed. A valid sequence is the following:

- Issue CMD command (CTRLBSET.CMD = command)
- Wait for CMD synchronization (SYNCBUSY.CTRLB = 0)
- Wait for CMD read back as zero (CTRLBSET.CMD = 0)

Value	Name	Description
0x0	NONE	No action
0x1	RETRIGGER	Force start, restart or retrigger
0x2	STOP	Force stop
0x3	UPDATE	Force update of double buffered registers
0x4	READSYNC	Force a read synchronization of COUNT
0x5	DMAOS	One-shot DMA trigger

#### Bits 4:3 – IDXCMD[1:0] Ramp Index Command

These bits can be used to force cycle A and cycle B changes in RAMP2 and RAMP2A operation. On timer/counter update condition, the command is executed, the IDX flag in the STATUS register is updated and the IDXCMD command is cleared.

Writing a zero to these bits has no effect.

Writing a valid value to these bits will set a command.

Value	Name	Description
0x0	DISABLE	Command disabled: IDX toggles between cycles A and B
0x1	SET	Set IDX: cycle B will be forced in the next cycle
0x2	CLEAR	Clear IDX: cycle A will be forced in next cycle
0x3	HOLD	Hold IDX: the next cycle will be the same as the current cycle.

**Bit 2 – ONSHOT** One-Shot

This bit controls one-shot operation of the TCC. When in one-shot operation, the TCC will stop counting on the next overflow/underflow condition or a stop command.

Writing a '0' to this bit has no effect.

Writing a '1' to this bit will enable the one-shot operation.

Value	Description
0	The TCC will count continuously.
1	The TCC will stop counting on the next underflow/overflow condition.

**Bit 1 – LUPD** Lock Update

This bit controls the update operation of the TCC buffered registers.

When CTRLB.LUPD is set, the hardware UPDATE registers with value from their buffered registers is disabled. Disabling the update ensures that all buffer registers are valid before an hardware update is performed. After all the buffer registers are loaded correctly, the buffered registers can be unlocked.

This bit has no effect when input capture operation is enabled.

Writing a '0' to this bit has no effect.

Writing a '1' to this bit will disable the registers updates on hardware UPDATE condition.

Value	Description
0	The CCBx, PERB, PGVB, and PGEB buffer registers values <i>are</i> copied into the corresponding CCx, PER, PGV, and PGE registers on hardware update condition.
1	The CCBx, PERB, PGVB, and PGEB buffer registers values are <i>not</i> copied into CCx, PER, PGV, and PGE registers on hardware update condition.

**Bit 0 – DIR** Counter Direction

This bit is used to change the direction of the counter.

Writing a '0' to this bit has no effect.

Writing a '1' to this bit will set the bit and make the counter count down.

**Note:** When the TCC is counting down, the COUNT register must be initialized to the TOP value (PER or CC0 value depending on the mode).

Value	Description
0	The timer/counter is counting up (incrementing).
1	The timer/counter is counting down (decrementing).

#### 45.7.4 Synchronization Busy

**Name:** SYNCBUSY  
**Offset:** 0x08  
**Reset:** 0x00000000  
**Property:** -

Bit	31	30	29	28	27	26	25	24
Access								
Reset								
Bit	23	22	21	20	19	18	17	16
Access								
Reset								
Bit	15	14	13	12	11	10	9	8
Access			CC5	CC4	CC3	CC2	CC1	CC0
Reset			R	R	R	R	R	R
Reset			0	0	0	0	0	0
Bit	7	6	5	4	3	2	1	0
Access	PER	WAVE	PATT	COUNT	STATUS	CTRLB	ENABLE	SWRST
Reset	R	R	R	R	R	R	R	R
Reset	0	0	0	0	0	0	0	0

##### Bits 8, 9, 10, 11, 12, 13 – CC Compare/Capture Channel x Synchronization Busy

This bit is cleared when the synchronization of Compare/Capture Channel x register between the clock domains is complete.

This bit is set when the synchronization of Compare/Capture Channel x register between clock domains is started.

CCx bit is available only for existing Compare/Capture Channels. For details on CC channels number, refer to each TCC feature list.

This bit is set when the synchronization of CCx register between clock domains is started.

##### Bit 7 – PER PER Synchronization Busy

This bit is cleared when the synchronization of PER register between the clock domains is complete.

This bit is set when the synchronization of PER register between clock domains is started.

##### Bit 6 – WAVE WAVE Synchronization Busy

This bit is cleared when the synchronization of WAVE register between the clock domains is complete.

This bit is set when the synchronization of WAVE register between clock domains is started.

##### Bit 5 – PATT PATT Synchronization Busy

This bit is cleared when the synchronization of PATTERN register between the clock domains is complete.

This bit is set when the synchronization of PATTERN register between clock domains is started.

##### Bit 4 – COUNT COUNT Synchronization Busy

This bit is cleared when the synchronization of COUNT register between the clock domains is complete.

This bit is set when the synchronization of COUNT register between clock domains is started.

**Bit 3 – STATUS** STATUS Synchronization Busy

This bit is cleared when the synchronization of STATUS register between the clock domains is complete.

This bit is set when the synchronization of STATUS register between clock domains is started.

**Bit 2 – CTRLB** CTRLB Synchronization Busy

This bit is cleared when the synchronization of CTRLB register between the clock domains is complete.

This bit is set when the synchronization of CTRLB register between clock domains is started.

**Bit 1 – ENABLE** ENABLE Synchronization Busy

This bit is cleared when the synchronization of ENABLE bit between the clock domains is complete.

This bit is set when the synchronization of ENABLE bit between clock domains is started.

**Bit 0 – SWRST** SWRST Synchronization Busy

This bit is cleared when the synchronization of SWRST bit between the clock domains is complete.

This bit is set when the synchronization of SWRST bit between clock domains is started.

### 45.7.5 Fault Control A and B

**Name:** FCTRLn  
**Offset:** 0x0C + n\*0x04 [n=0..1]  
**Reset:** 0x00000000  
**Property:** PAC Write-Protection, Enable-Protected

Bit	31	30	29	28	27	26	25	24
	FILTERVAL[3:0]							
Access					R/W	R/W	R/W	R/W
Reset					0	0	0	0
Bit	23	22	21	20	19	18	17	16
	BLANKVAL[7:0]							
Access	R/W	R/W	R/W	R/W	R/W	R/W	R/W	R/W
Reset	0	0	0	0	0	0	0	0
Bit	15	14	13	12	11	10	9	8
	BLANKPRESC	CAPTURE[2:0]			CHSEL[1:0]		HALT[1:0]	
Access	R/W	R/W	R/W	R/W	R/W	R/W	R/W	R/W
Reset	0	0	0	0	0	0	0	0
Bit	7	6	5	4	3	2	1	0
	RESTART	BLANK[1:0]		QUAL	KEEP		SRC[1:0]	
Access	R/W	R/W	R/W	R/W	R/W		R/W	R/W
Reset	0	0	0	0	0		0	0

#### Bits 27:24 – FILTERVAL[3:0] Recoverable Fault n Filter Value

These bits define the filter value applied on MCE<sub>x</sub> (x=0,1) event input line. The value must be set to zero when MCE<sub>x</sub> event is used as synchronous event.

#### Bits 23:16 – BLANKVAL[7:0] Recoverable Fault n Blanking Value

These bits determine the duration of the blanking of the fault input source. Activation and edge selection of the blank filtering are done by the BLANK bits (FCTRLn.BLANK). When enabled, the fault input source is internally disabled for BLANKVAL\* prescaled GCLK\_TCC<sub>x</sub> periods after the detection of the waveform edge.

#### Bit 15 – BLANKPRESC Recoverable Fault n Blanking Value Prescaler

This bit enables a factor 64 prescaler factor on used as base frequency of the BLANKVAL value.

Value	Description
0	Blank time is BLANKVAL* prescaled GCLK_TCC <sub>x</sub> .
1	Blank time is BLANKVAL* 64 * prescaled GCLK_TCC <sub>x</sub> .

#### Bits 14:12 – CAPTURE[2:0] Recoverable Fault n Capture Action

These bits select the capture and Fault n interrupt/event conditions.

**Table 45-9.** Fault n Capture Action

Value	Name	Description
0x0	DISABLE	Capture on valid recoverable Fault n is disabled
0x1	CAPT	On rising edge of a valid recoverable Fault n, capture counter value on channel selected by CHSEL[1:0]. INTFLAG.FAULTn flag rises on each new captured value.
0x2	CAPTMIN	On rising edge of a valid recoverable Fault n, capture counter value on channel selected by CHSEL[1:0], if COUNT value is lower than the last stored capture value (CC). INTFLAG.FAULTn flag rises on each local minimum detection.

.....continued

Value	Name	Description
0x3	CAPTMAX	On rising edge of a valid recoverable Fault n, capture counter value on channel selected by CHSEL[1:0], if COUNT value is higher than the last stored capture value (CC). INTFLAG.FAULTn flag rises on each local maximum detection.
0x4	LOCMIN	On rising edge of a valid recoverable Fault n, capture counter value on channel selected by CHSEL[1:0]. INTFLAG.FAULTn flag rises on each local minimum value detection.
0x5	LOCMAX	On rising edge of a valid recoverable Fault n, capture counter value on channel selected by CHSEL[1:0]. INTFLAG.FAULTn flag rises on each local maximum detection.
0x6	DERIVO	On rising edge of a valid recoverable Fault n, capture counter value on channel selected by CHSEL[1:0]. INTFLAG.FAULTn flag rises on each local maximum or minimum detection.
0x7	CAPTMARK	Capture with ramp index as MSB value.

**Bits 11:10 – CHSEL[1:0]** Recoverable Fault n Capture Channel

These bits select the channel for capture operation triggered by recoverable Fault n.

Value	Name	Description
0x0	CC0	Capture value stored into CC0
0x1	CC1	Capture value stored into CC1
0x2	CC2	Capture value stored into CC2
0x3	CC3	Capture value stored into CC3

**Bits 9:8 – HALT[1:0]** Recoverable Fault n Halt Operation

These bits select the halt action for recoverable Fault n.

Value	Name	Description
0x0	DISABLE	Halt action disabled
0x1	HW	Hardware halt action
0x2	SW	Software halt action
0x3	NR	Non-recoverable fault

**Bit 7 – RESTART** Recoverable Fault n Restart

Setting this bit enables restart action for Fault n.

Value	Description
0	Fault n restart action is disabled.
1	Fault n restart action is enabled.

**Bits 6:5 – BLANK[1:0]** Recoverable Fault n Blanking Operation

These bits, select the blanking start point for recoverable Fault n.

Value	Name	Description
0x0	START	Blanking applied from start of the Ramp period
0x1	RISE	Blanking applied from rising edge of the waveform output
0x2	FALL	Blanking applied from falling edge of the waveform output
0x3	BOTH	Blanking applied from each toggle of the waveform output

**Bit 4 – QUAL** Recoverable Fault n Qualification

Setting this bit enables the recoverable Fault n input qualification.

Value	Description
0	The recoverable Fault n input is not disabled on CMPx value condition.
1	The recoverable Fault n input is disabled when output signal is at inactive level (CMPx == 0).

**Bit 3 – KEEP** Recoverable Fault n Keep

Setting this bit enables the Fault n keep action.

Value	Description
0	The Fault n state is released as soon as the recoverable Fault n is released.
1	The Fault n state is released at the end of TCC cycle.

**Bits 1:0 – SRC[1:0]** Recoverable Fault n Source

These bits select the TCC event input for recoverable Fault n.

Event system channel connected to MCE<sub>x</sub> event input, must be configured to route the event asynchronously, when used as a recoverable Fault n input.

Value	Name	Description
0x0	DISABLE	Fault input disabled
0x1	ENABLE	MCE <sub>x</sub> (x=0,1) event input
0x2	INVERT	Inverted MCE <sub>x</sub> (x=0,1) event input
0x3	ALTFAULT	Alternate fault (A or B) state at the end of the previous period.

## 45.7.6 Waveform Extension Control

**Name:** WEXCTRL  
**Offset:** 0x14  
**Reset:** 0x00000000  
**Property:** PAC Write-Protection, Enable-Protected

Bit	31	30	29	28	27	26	25	24
	DTHS[7:0]							
Access	R/W	R/W	R/W	R/W	R/W	R/W	R/W	R/W
Reset	0	0	0	0	0	0	0	0
Bit	23	22	21	20	19	18	17	16
	DTLS[7:0]							
Access	R/W	R/W	R/W	R/W	R/W	R/W	R/W	R/W
Reset	0	0	0	0	0	0	0	0
Bit	15	14	13	12	11	10	9	8
					DTIEN3	DTIEN2	DTIEN1	DTIEN0
Access					R/W	R/W	R/W	R/W
Reset					0	0	0	0
Bit	7	6	5	4	3	2	1	0
							OTMX[1:0]	
Access							R/W	R/W
Reset							0	0

### Bits 31:24 – DTHS[7:0] Dead-Time High Side Outputs Value

This register holds the number of GCLK\_TCCx clock cycles for the dead-time high side.

### Bits 23:16 – DTLS[7:0] Dead-time Low Side Outputs Value

This register holds the number of GCLK\_TCCx clock cycles for the dead-time low side.

### Bits 8, 9, 10, 11 – DTIENx Dead-time Insertion Generator x Enable

Setting any of these bits enables the dead-time insertion generator for the corresponding output matrix. This will override the output matrix [x] and [x+WO\_NUM/2], with the low side and high side waveform respectively.

Value	Description
0	No dead-time insertion override.
1	Dead time insertion override on signal outputs[x] and [x+WO_NUM/2], from matrix outputs[x] signal.

### Bits 1:0 – OTMX[1:0] Output Matrix

These bits define the matrix routing of the TCC waveform generation outputs to the port pins, according to [45.6.3.8. Waveform Extension](#).



### 45.7.7 Driver Control

**Name:** DRVCTRL  
**Offset:** 0x18  
**Reset:** 0x00000000  
**Property:** PAC Write-Protection, Enable-Protected

Bit	31	30	29	28	27	26	25	24
	FILTERVAL1[3:0]				FILTERVAL0[3:0]			
Access	R/W	R/W	R/W	R/W	R/W	R/W	R/W	R/W
Reset	0	0	0	0	0	0	0	0
Bit	23	22	21	20	19	18	17	16
	INVEN7	INVEN6	INVEN5	INVEN4	INVEN3	INVEN2	INVEN1	INVEN0
Access	R/W	R/W	R/W	R/W	R/W	R/W	R/W	R/W
Reset	0	0	0	0	0	0	0	0
Bit	15	14	13	12	11	10	9	8
	NRV7	NRV6	NRV5	NRV4	NRV3	NRV2	NRV1	NRV0
Access	R/W	R/W	R/W	R/W	R/W	R/W	R/W	R/W
Reset	0	0	0	0	0	0	0	0
Bit	7	6	5	4	3	2	1	0
	NRE7	NRE6	NRE5	NRE4	NRE3	NRE2	NRE1	NRE0
Access	R/W	R/W	R/W	R/W	R/W	R/W	R/W	R/W
Reset	0	0	0	0	0	0	0	0

#### Bits 31:28 – FILTERVAL1[3:0] Non-Recoverable Fault Input 1 Filter Value

These bits define the filter value applied on TCE1 event input line. When the TCE1 event input line is configured as a synchronous event, this value must be 0x0.

#### Bits 27:24 – FILTERVAL0[3:0] Non-Recoverable Fault Input 0 Filter Value

These bits define the filter value applied on TCE0 event input line. When the TCE0 event input line is configured as a synchronous event, this value must be 0x0.

#### Bits 16, 17, 18, 19, 20, 21, 22, 23 – INVENx Waveform Output x Inversion

These bits are used to select inversion on the output of channel x.  
 Writing a '1' to INVENx inverts output from WO[x].  
 Writing a '0' to INVENx disables inversion of output from WO[x].

#### Bits 8, 9, 10, 11, 12, 13, 14, 15 – NRVx NRVx Non-Recoverable State x Output Value

These bits define the value of the enabled override outputs, under non-recoverable fault condition.

#### Bits 0, 1, 2, 3, 4, 5, 6, 7 – NREx Non-Recoverable State x Output Enable

These bits enable the override of individual outputs by NRVx value, under non-recoverable fault condition.

Value	Description
0	Non-recoverable fault tri-state the output.
1	Non-recoverable faults set the output to NRVx level.

### 45.7.8 Debug control

**Name:** DBGCTRL  
**Offset:** 0x1E  
**Reset:** 0x00  
**Property:** PAC Write-Protection

Bit	7	6	5	4	3	2	1	0
						FDDBD		DBGRUN
Access						R/W		R/W
Reset						0		0

#### Bit 2 – FDDBD Fault Detection on Debug Break Detection

This bit is not affected by software Reset and should not be changed by software while the TCC is enabled.

By default this bit is zero, and the on-chip debug (OCD) fault protection is disabled. When this bit is written to '1', OCD break request from the OCD system will trigger non-recoverable fault. When this bit is set, OCD fault protection is enabled and OCD break request from the OCD system will trigger a non-recoverable fault.

Value	Description
0	No faults are generated when TCC is halted in Debug mode.
1	A non recoverable fault is generated and FAULTD flag is set when TCC is halted in Debug mode.

#### Bit 0 – DBGRUN Debug Running State

This bit is not affected by software Reset and should not be changed by software while the TCC is enabled.

Value	Description
0	The TCC is halted when the device is halted in Debug mode.
1	The TCC continues normal operation when the device is halted in Debug mode.

## 45.7.9 Event Control

**Name:** EVCTRL  
**Offset:** 0x20  
**Reset:** 0x00000000  
**Property:** PAC Write-Protection, Enable-Protected

Bit	31	30	29	28	27	26	25	24
			MCEO5	MCEO4	MCEO3	MCEO2	MCEO1	MCEO0
Access			R/W	R/W	R/W	R/W	R/W	R/W
Reset			0	0	0	0	0	0
Bit	23	22	21	20	19	18	17	16
			MCEI5	MCEI4	MCEI3	MCEI2	MCEI1	MCEI0
Access			R/W	R/W	R/W	R/W	R/W	R/W
Reset			0	0	0	0	0	0
Bit	15	14	13	12	11	10	9	8
	TCEI1	TCEI0	TCINV1	TCINV0		CNTE0	TRGEO	OVFEO
Access	R/W	R/W	R/W	R/W		R/W	R/W	R/W
Reset	0	0	0	0		0	0	0
Bit	7	6	5	4	3	2	1	0
	CNTSEL[1:0]		EVACT1[2:0]			EVACT0[2:0]		
Access	R/W	R/W	R/W	R/W	R/W	R/W	R/W	R/W
Reset	0	0	0	0	0	0	0	0

**Bits 24, 25, 26, 27, 28, 29 – MCEOx** Match or Capture Channel x Event Output Enable, x = 0..5  
 These bits control if the match/capture event on channel x is enabled and will be generated for every match or capture.

Value	Description
0	Match/capture x event is disabled and will not be generated.
1	Match/capture x event is enabled and will be generated for every compare/capture on channel x.

**Bits 16, 17, 18, 19, 20, 21 – MCEIx** Match or Capture Channel x Event Input Enable, x = 0..5  
 These bits indicate if the match/capture x incoming event is enabled  
 These bits are used to enable match or capture input events to the CCx channel of TCC.  
**Note:** The channel path of the Event System must be configured as an Asynchronous path (CHANNELx.PATH = 0x2).

Value	Description
0	Incoming events are disabled.
1	Incoming events are enabled.

**Bits 14, 15 – TCEIx** Timer/Counter Event Input x Enable, x=0,1  
 This bit is used to enable input event x to the TCC.  
**Note:** The channel path of the Event System must be configured as an Asynchronous path (CHANNELx.PATH = 0x2).

Value	Description
0	Incoming event x is disabled.
1	Incoming event x is enabled.

**Bits 12, 13 – TCINVx** Timer/Counter Event x Invert Enable, x=0,1  
 This bit inverts the event x input.

Value	Description
0	Input event source x is not inverted.
1	Input event source x is inverted.

**Bit 10 – CNTEO** Timer/Counter Event Output Enable

This bit is used to enable the counter cycle event. When enabled, an event will be generated on begin or end of counter cycle depending of CNTSEL[1:0] settings.

Value	Description
0	Counter cycle output event is disabled and will not be generated.
1	Counter cycle output event is enabled and will be generated depend of CNTSEL[1:0] value.

**Bit 9 – TRGEO** Retrigger Event Output Enable

This bit is used to enable the counter retrigger event. When enabled, an event will be generated when the counter retriggers operation.

Value	Description
0	Counter retrigger event is disabled and will not be generated.
1	Counter retrigger event is enabled and will be generated for every counter retrigger.

**Bit 8 – OVFE0** Overflow/Underflow Event Output Enable

This bit is used to enable the overflow/underflow event. When enabled an event will be generated when the counter reaches the TOP or the ZERO value.

Value	Description
0	Overflow/underflow counter event is disabled and will not be generated.
1	Overflow/underflow counter event is enabled and will be generated for every counter overflow/underflow.

**Bits 7:6 – CNTSEL[1:0]** Timer/Counter Interrupt and Event Output Selection

These bits define on which part of the counter cycle the counter event output is generated.

Value	Name	Description
0x0	START	An interrupt/event is generated at begin of each counter cycle
0x1	END	An interrupt/event is generated at end of each counter cycle
0x2	BETWEEN	An interrupt/event is generated between each counter cycle.
0x3	BOUNDARY	An interrupt/event is generated at begin of first counter cycle, and end of last counter cycle.

**Bits 5:3 – EVACT1[2:0]** Timer/Counter Event Input 1 Action

These bits define the action the TCC will perform on TCE1 event input.

**Note:** RETRIGGER action is not supported in Dithering mode or RAMP2 operations.

Value	Name	Description
0x0	OFF	Event action disabled.
0x1	RETRIGGER	Start, restart or re-trigger TCC on event
0x2	DIR	Direction control
0x3	STOP	Stop TCC on event
0x4	DEC	Decrement TCC on event
0x5	PPW	Period captured into CC0 Pulse Width on CC1
0x6	PWP	Period captured into CC1 Pulse Width on CC0
0x7	FAULT	Non-recoverable Fault

**Bits 2:0 – EVACT0[2:0]** Timer/Counter Event Input 0 Action

These bits define the action the TCC will perform on TCE0 event input 0.

**Note:** RETRIGGER action is not supported in Dithering mode or RAMP2 operations.

Value	Name	Description
0x0	OFF	Event action disabled.
0x1	RETRIGGER	Start, restart or re-trigger TCC on event
0x2	COUNTEV	Count on event.
0x3	START	Start TCC on event
0x4	INC	Increment TCC on EVENT

Value	Name	Description
0x5	COUNT	Count on active state of asynchronous event
0x6	STAMP	Capture overflow times (Max value)
0x7	FAULT	Non-recoverable Fault

### 45.7.10 Interrupt Enable Clear

**Name:** INTENCLR  
**Offset:** 0x24  
**Reset:** 0x00000000  
**Property:** PAC Write-Protection

This register allows the user to enable an interrupt without doing a read-modify-write operation. Changes in this register will also be reflected in the Interrupt Enable Set (INTENSET) register.

Bit	31	30	29	28	27	26	25	24
Access								
Reset								
Bit	23	22	21	20	19	18	17	16
Access			MC5	MC4	MC3	MC2	MC1	MC0
Reset			R/W	R/W	R/W	R/W	R/W	R/W
Reset			0	0	0	0	0	0
Bit	15	14	13	12	11	10	9	8
Access	FAULT1	FAULT0	FAULTB	FAULTA	DFS	UFS		
Reset	R/W	R/W	R/W	R/W	R/W	R/W		
Reset	0	0	0	0	0	0		
Bit	7	6	5	4	3	2	1	0
Access					ERR	CNT	TRG	OVF
Reset					R/W	R/W	R/W	R/W
Reset					0	0	0	0

#### Bits 16, 17, 18, 19, 20, 21 – MCx Match or Capture Channel x Interrupt Enable, x=0..5

Writing a '0' to this bit has no effect.

Writing a '1' to this bit will clear the corresponding Match or Capture Channel x Interrupt Disable/Enable bit, which disables the Match or Capture Channel x interrupt.

Value	Description
0	The Match or Capture Channel x interrupt is disabled.
1	The Match or Capture Channel x interrupt is enabled.

#### Bit 15 – FAULT1 Non-Recoverable Fault x Interrupt Enable

Writing a '0' to this bit has no effect.

Writing a '1' to this bit will clear the Non-Recoverable Fault x Interrupt Disable/Enable bit, which disables the Non-Recoverable Fault x interrupt.

Value	Description
0	The Non-Recoverable Fault x interrupt is disabled.
1	The Non-Recoverable Fault x interrupt is enabled.

#### Bit 14 – FAULT0 Non-Recoverable Fault x Interrupt Enable

Writing a '0' to this bit has no effect.

Writing a '1' to this bit will clear the Non-Recoverable Fault x Interrupt Disable/Enable bit, which disables the Non-Recoverable Fault x interrupt.

Value	Description
0	The Non-Recoverable Fault x interrupt is disabled.
1	The Non-Recoverable Fault x interrupt is enabled.

**Bit 13 – FAULTB** Recoverable Fault B Interrupt Enable

Writing a '0' to this bit has no effect.

Writing a '1' to this bit will clear the Recoverable Fault B Interrupt Disable/Enable bit, which disables the Recoverable Fault B interrupt.

Value	Description
0	The Recoverable Fault B interrupt is disabled.
1	The Recoverable Fault B interrupt is enabled.

**Bit 12 – FAULTA** Recoverable Fault A Interrupt Enable

Writing a '0' to this bit has no effect.

Writing a '1' to this bit will clear the Recoverable Fault A Interrupt Disable/Enable bit, which disables the Recoverable Fault A interrupt.

Value	Description
0	The Recoverable Fault A interrupt is disabled.
1	The Recoverable Fault A interrupt is enabled.

**Bit 11 – DFS** Non-Recoverable Debug Fault Interrupt Enable

Writing a '0' to this bit has no effect.

Writing a '1' to this bit will clear the Debug Fault State Interrupt Disable/Enable bit, which disables the Debug Fault State interrupt.

Value	Description
0	The Debug Fault State interrupt is disabled.
1	The Debug Fault State interrupt is enabled.

**Bit 10 – UFS** Non-Recoverable Update Fault Interrupt Enable

Writing a zero to this bit has no effect.

Writing a one to this bit will clear the Non-Recoverable Update Fault Interrupt Disable/Enable bit, which disables the Non-Recoverable Update Fault interrupt.

**Note:** This bit is only available on variant L devices. Refer to the [Configuration Summary](#) for more information.

Value	Description
0	The Non-Recoverable Update Fault interrupt is disabled.
1	The Non-Recoverable Update Fault interrupt is enabled.

**Bit 3 – ERR** Error Interrupt Enable

Writing a '0' to this bit has no effect.

Writing a '1' to this bit will clear the Error Interrupt Disable/Enable bit, which disables the Compare interrupt.

Value	Description
0	The Error interrupt is disabled.
1	The Error interrupt is enabled.

**Bit 2 – CNT** Counter Interrupt Enable

Writing a '0' to this bit has no effect.

Writing a '1' to this bit will clear the Counter Interrupt Disable/Enable bit, which disables the Counter interrupt.

Value	Description
0	The Counter interrupt is disabled.
1	The Counter interrupt is enabled.

**Bit 1 – TRG** Retrigger Interrupt Enable

Writing a '0' to this bit has no effect.

Writing a '1' to this bit will clear the Retrigger Interrupt Disable/Enable bit, which disables the Retrigger interrupt.

Value	Description
0	The Retrigger interrupt is disabled.

Value	Description
1	The Retrigger interrupt is enabled.

**Bit 0 – OVF** Overflow Interrupt Enable

Writing a '0' to this bit has no effect.

Writing a '1' to this bit will clear the Overflow Interrupt Disable/Enable bit, which disables the Overflow interrupt request.

Value	Description
0	The Overflow interrupt is disabled.
1	The Overflow interrupt is enabled.



### 45.7.11 Interrupt Enable Set

**Name:** INTENSET  
**Offset:** 0x28  
**Reset:** 0x00000000  
**Property:** PAC Write-Protection

This register allows the user to enable an interrupt without doing a read-modify-write operation. Changes in this register will also be reflected in the Interrupt Enable Clear (INTENCLR) register.

Bit	31	30	29	28	27	26	25	24
Access								
Reset								
Bit	23	22	21	20	19	18	17	16
Access			MC5	MC4	MC3	MC2	MC1	MC0
Reset			R/W	R/W	R/W	R/W	R/W	R/W
Reset			0	0	0	0	0	0
Bit	15	14	13	12	11	10	9	8
Access	FAULT1	FAULT0	FAULTB	FAULTA	DFS	UFS		
Reset	R/W	R/W	R/W	R/W	R/W	R/W		
Reset	0	0	0	0	0	0		
Bit	7	6	5	4	3	2	1	0
Access					ERR	CNT	TRG	OVF
Reset					R/W	R/W	R/W	R/W
Reset					0	0	0	0

#### Bits 16, 17, 18, 19, 20, 21 – MCx Match or Capture Channel x Interrupt Enable, x = 0..5

Writing a '0' to this bit has no effect.

Writing a '1' to this bit will set the corresponding Match or Capture Channel x Interrupt Disable/Enable bit, which enables the Match or Capture Channel x interrupt.

Value	Description
0	The Match or Capture Channel x interrupt is disabled.
1	The Match or Capture Channel x interrupt is enabled.

#### Bit 15 – FAULT1 Non-Recoverable Fault x Interrupt Enable

Writing a '0' to this bit has no effect.

Writing a '1' to this bit will set the Non-Recoverable Fault x Interrupt Disable/Enable bit, which enables the Non-Recoverable Fault x interrupt.

Value	Description
0	The Non-Recoverable Fault x interrupt is disabled.
1	The Non-Recoverable Fault x interrupt is enabled.

#### Bit 14 – FAULT0 Non-Recoverable Fault x Interrupt Enable

Writing a '0' to this bit has no effect.

Writing a '1' to this bit will clear the Non-Recoverable Fault x Interrupt Disable/Enable bit, which disables the Non-Recoverable Fault x interrupt.

Value	Description
0	The Non-Recoverable Fault x interrupt is disabled.
1	The Non-Recoverable Fault x interrupt is enabled.

**Bit 13 – FAULTB** Recoverable Fault B Interrupt Enable

Writing a '0' to this bit has no effect.

Writing a '1' to this bit will set the Recoverable Fault B Interrupt Disable/Enable bit, which enables the Recoverable Fault B interrupt.

Value	Description
0	The Recoverable Fault B interrupt is disabled.
1	The Recoverable Fault B interrupt is enabled.

**Bit 12 – FAULTA** Recoverable Fault A Interrupt Enable

Writing a '0' to this bit has no effect.

Writing a '1' to this bit will set the Recoverable Fault A Interrupt Disable/Enable bit, which enables the Recoverable Fault A interrupt.

Value	Description
0	The Recoverable Fault A interrupt is disabled.
1	The Recoverable Fault A interrupt is enabled.

**Bit 11 – DFS** Non-Recoverable Debug Fault Interrupt Enable

Writing a '0' to this bit has no effect.

Writing a '1' to this bit will set the Debug Fault State Interrupt Disable/Enable bit, which enables the Debug Fault State interrupt.

Value	Description
0	The Debug Fault State interrupt is disabled.
1	The Debug Fault State interrupt is enabled.

**Bit 10 – UFS** Non-Recoverable Update Fault Interrupt Enable

Writing a zero to this bit has no effect.

Writing a one to this bit will set the Non-Recoverable Update Fault Interrupt Disable/Enable bit, which enables the Non-Recoverable Update Fault interrupt.

**Note:** This bit is only available on variant L devices. Refer to the [Configuration Summary](#) for more information.

Value	Description
0	The Non-Recoverable Update Fault interrupt is disabled.
1	The Non-Recoverable Update Fault interrupt is enabled.

**Bit 3 – ERR** Error Interrupt Enable

Writing a '0' to this bit has no effect.

Writing a '1' to this bit will set the Error Interrupt Disable/Enable bit, which enables the Compare interrupt.

Value	Description
0	The Error interrupt is disabled.
1	The Error interrupt is enabled.

**Bit 2 – CNT** Counter Interrupt Enable

Writing a '0' to this bit has no effect.

Writing a '1' to this bit will set the Retrigger Interrupt Disable/Enable bit, which enables the Counter interrupt.

Value	Description
0	The Counter interrupt is disabled.
1	The Counter interrupt is enabled.

**Bit 1 – TRG** Retrigger Interrupt Enable

Writing a '0' to this bit has no effect.

Writing a '1' to this bit will set the Retrigger Interrupt Disable/Enable bit, which enables the Retrigger interrupt.

Value	Description
0	The Retrigger interrupt is disabled.

Value	Description
1	The Retrigger interrupt is enabled.

**Bit 0 – OVF** Overflow Interrupt Enable

Writing a '0' to this bit has no effect.

Writing a '1' to this bit will set the Overflow Interrupt Disable/Enable bit, which enables the Overflow interrupt request.

Value	Description
0	The Overflow interrupt is disabled.
1	The Overflow interrupt is enabled.

### 45.7.12 Interrupt Flag Status and Clear

**Name:** INTFLAG  
**Offset:** 0x2C  
**Reset:** 0x00000000  
**Property:** -

Bit	31	30	29	28	27	26	25	24
Access								
Reset								
Bit	23	22	21	20	19	18	17	16
Access			MC5	MC4	MC3	MC2	MC1	MC0
Reset			R/W	R/W	R/W	R/W	R/W	R/W
Reset			0	0	0	0	0	0
Bit	15	14	13	12	11	10	9	8
Access	FAULT1	FAULT0	FAULTB	FAULTA	DFS	UFS		
Reset	R/W	R/W	R/W	R/W	R/W	R/W		
Reset	0	0	0	0	0	0		
Bit	7	6	5	4	3	2	1	0
Access					ERR	CNT	TRG	OVF
Reset					R/W	R/W	R/W	R/W
Reset					0	0	0	0

#### Bits 16, 17, 18, 19, 20, 21 – MCx Match or Capture Channel x Interrupt Flag, x=0..5

This flag is set on the next CLK\_TCC\_COUNT cycle after a match with the compare condition or once CCx register contain a valid capture value.

Writing a '0' to one of these bits has no effect.

Writing a '1' to one of these bits will clear the corresponding Match or Capture Channel x interrupt flag

In Capture operation, this flag is automatically cleared when CCx register is read.

#### Bit 15 – FAULT1 Non-Recoverable Fault x Interrupt Flag

This flag is set on the next CLK\_TCC\_COUNT cycle after a Non-Recoverable Fault x occurs.

Writing a '0' to this bit has no effect.

Writing a '1' to this bit clears the Non-Recoverable Fault x interrupt flag.

#### Bit 14 – FAULT0 Non-Recoverable Fault x Interrupt Enable

Writing a '0' to this bit has no effect.

Writing a '1' to this bit will clear the Non-Recoverable Fault x Interrupt Disable/Enable bit, which disables the Non-Recoverable Fault x interrupt.

Value	Description
0	The Non-Recoverable Fault x interrupt is disabled.
1	The Non-Recoverable Fault x interrupt is enabled.

#### Bit 13 – FAULTB Recoverable Fault B Interrupt Flag

This flag is set on the next CLK\_TCC\_COUNT cycle after a Recoverable Fault B occurs.

Writing a '0' to this bit has no effect.

Writing a '1' to this bit clears the Recoverable Fault B interrupt flag.

**Bit 12 – FAULTA** Recoverable Fault A Interrupt Flag

This flag is set on the next CLK\_TCC\_COUNT cycle after a Recoverable Fault B occurs.  
Writing a '0' to this bit has no effect.  
Writing a '1' to this bit clears the Recoverable Fault B interrupt flag.

**Bit 11 – DFS** Non-Recoverable Debug Fault State Interrupt Flag

This flag is set on the next CLK\_TCC\_COUNT cycle after an Debug Fault State occurs.  
Writing a '0' to this bit has no effect.  
Writing a '1' to this bit clears the Debug Fault State interrupt flag.

**Bit 10 – UFS** Non-Recoverable Update Fault

This flag is set when the RAMP index changes and the Lock Update bit is set (CTRLBSET.LUPD).  
Writing a zero to this bit has no effect.  
Writing a one to this bit clears the Non-Recoverable Update Fault interrupt flag.

**Note:** This bit is only available on variant L devices. Refer to the [Configuration Summary](#) for more information.

**Bit 3 – ERR** Error Interrupt Flag

This flag is set if a new capture occurs on a channel when the corresponding Match or Capture Channel x interrupt flag is one. In which case there is nowhere to store the new capture.  
Writing a '0' to this bit has no effect.  
Writing a '1' to this bit clears the error interrupt flag.

**Bit 2 – CNT** Counter Interrupt Flag

This flag is set on the next CLK\_TCC\_COUNT cycle after a counter event occurs.  
Writing a '0' to this bit has no effect.  
Writing a '1' to this bit clears the CNT interrupt flag.

**Bit 1 – TRG** Retrigger Interrupt Flag

This flag is set on the next CLK\_TCC\_COUNT cycle after a counter retrigger occurs.  
Writing a '0' to this bit has no effect.  
Writing a '1' to this bit clears the re-trigger interrupt flag.

**Bit 0 – OVF** Overflow Interrupt Flag

This flag is set on the next CLK\_TCC\_COUNT cycle after an overflow condition occurs.  
Writing a '0' to this bit has no effect.  
Writing a '1' to this bit clears the Overflow interrupt flag.

### 45.7.13 Status

**Name:** STATUS  
**Offset:** 0x30  
**Reset:** 0x00000001  
**Property:** Read-Synchronized, Write-Synchronized



**Important:** 8-bit or 16-bit writes to this register are forbidden.

**Note:** This register is read-synchronized and write-synchronized: SYNCBUSY.STATUS must be checked to ensure the STATUS register synchronization is complete.

Bit	31	30	29	28	27	26	25	24
			CMP5	CMP4	CMP3	CMP2	CMP1	CMP0
Access			R/W	R/W	R/W	R/W	R/W	R/W
Reset			0	0	0	0	0	0
Bit	23	22	21	20	19	18	17	16
			CCBUFV5	CCBUFV4	CCBUFV3	CCBUFV2	CCBUFV1	CCBUFV0
Access			R/W	R/W	R/W	R/W	R/W	R/W
Reset			0	0	0	0	0	0
Bit	15	14	13	12	11	10	9	8
	FAULT1	FAULT0	FAULTB	FAULTA	FAULT1IN	FAULT0IN	FAULTBIN	FAULTAIN
Access	R/W	R/W	R/W	R/W	R	R	R	R
Reset	0	0	0	0	0	0	0	0
Bit	7	6	5	4	3	2	1	0
	PERBUFV		PATTBUFV	SLAVE	DFS	UFS	IDX	STOP
Access	R/W		R/W	R	R/W	R/W	R	R
Reset	0		0	0	0	0	0	1

#### Bits 24, 25, 26, 27, 28, 29 – CMPx Channel x Compare Value, x=0..5

This bit reflects the channel x output compare value.

Value	Description
0	Channel compare output value is 0.
1	Channel compare output value is 1.

#### Bits 16, 17, 18, 19, 20, 21 – CCBUFVx Channel x Compare or Capture Buffer Valid, x=0..5

For a compare channel, this bit is set when a new value is written to the corresponding CCBUFx register. The bit is cleared either by writing a '1' to the corresponding location when CTRLB.LUPD is set, or automatically on an UPDATE condition.

For a capture channel, the bit is set when a valid capture value is stored in the CCBUFx register. The bit is automatically cleared when the CCx register is read.

#### Bits 14, 15 – FAULTx Non-recoverable Fault x State

This bit is set by hardware as soon as non-recoverable Fault x condition occurs.

This bit is cleared by writing a one to this bit and when the corresponding FAULTxIN status bit is low. Once this bit is clear, the timer/counter will restart from the last COUNT value. To restart the timer/counter from BOTTOM, the timer/counter restart command must be executed before clearing

the corresponding STATEx bit. For further details on timer/counter commands, refer to available commands description ([45.7.3. CTRLBSET.CMD](#)).

**Bit 13 – FAULTB** Recoverable Fault B State

This bit is set by hardware as soon as recoverable Fault B condition occurs.

This bit can be clear by hardware when Fault B action is resumed, or by writing a '1' to this bit when the corresponding FAULTBIN bit is low. If software halt command is enabled (FAULTB.HALT = SW), clearing this bit will release the timer/counter.

**Bit 12 – FAULTA** Recoverable Fault A State

This bit is set by hardware as soon as recoverable Fault A condition occurs.

This bit can be clear by hardware when Fault A action is resumed, or by writing a '1' to this bit when the corresponding FAULTAIN bit is low. If software halt command is enabled (FAULTA.HALT = SW), clearing this bit will release the timer/counter.

**Bit 11 – FAULT1IN** Non-Recoverable Fault 1 Input

This bit is set while an active Non-Recoverable Fault 1 input is present.

**Bit 10 – FAULT0IN** Non-Recoverable Fault 0 Input

This bit is set while an active Non-Recoverable Fault 0 input is present.

**Bit 9 – FAULTBIN** Recoverable Fault B Input

This bit is set while an active Recoverable Fault B input is present.

**Bit 8 – FAULTAIN** Recoverable Fault A Input

This bit is set while an active Recoverable Fault A input is present.

**Bit 7 – PERBUFV** Period Buffer Valid

This bit is set when a new value is written to the PERBUF register. This bit is automatically cleared by hardware on UPDATE condition when CTRLB.LUPD is set, or by writing a '1' to this bit.

**Bit 5 – PATTBUFV** Pattern Generator Value Buffer Valid

This bit is set when a new value is written to the PATTBUF register. This bit is automatically cleared by hardware on UPDATE condition when CTRLB.LUPD is set, or by writing a '1' to this bit.

**Bit 4 – SLAVE** Client

This bit is set when TCC is set in Client mode. This bit follows the CTRLA.MSYNC bit state.

**Bit 3 – DFS** Debug Fault State

This bit is set by hardware in Debug mode when the DDBGCTRL.FDDBD bit is set. The bit is cleared by writing a '1' to this bit and when the TCC is not in Debug mode.

When the bit is set, the counter is halted and the Waveforms state depend on the DRVCTRL.NRE and DRVCTRL.NRV registers.

**Bit 2 – UFS** Non-recoverable Update Fault State

This bit is set by hardware when the RAMP index changes and the Lock Update bit is set (CTRLBSET.LUPD). The bit is cleared by writing a one to this bit.

When the bit is set, the waveforms state depend on the DRVCTRL.NRE and DRVCTRL.NRV registers.

**Bit 1 – IDX** Ramp Index

In RAMP2 and RAMP2A operation, the bit is cleared during the cycle A and set during the cycle B. In RAMP1 operation, the bit always reads zero. For details on ramp operations, refer to [45.6.3.4. Ramp Operations](#).

**Bit 0 – STOP** Stop

This bit is set when the TCC is disabled either on a STOP command or on an UPDATE condition when One-Shot operation mode is enabled (CTRLBSET.ONESHOT = 1).

This bit is clear on the next incoming counter increment or decrement.

Value	Description
0	Counter is running.
1	Counter is stopped.



#### 45.7.14 Counter Value

**Name:** COUNT  
**Offset:** 0x34  
**Reset:** 0x00000000  
**Property:** PAC Write-Protection, Write-Synchronized

#### Notes:

1. Prior to any read access, this register must be synchronized by user by writing the according TCC Command value to the Control B Set register (CTRLBSET.CMD=READSYNC).
2. This register is write-synchronized: SYNCBUSY.COUNT must be checked to ensure the COUNT register synchronization is complete.

Bit	31	30	29	28	27	26	25	24
Access								
Reset								
Bit	23	22	21	20	19	18	17	16
Access	COUNT[23:16]							
Reset	R/W	R/W	R/W	R/W	R/W	R/W	R/W	R/W
Reset	0	0	0	0	0	0	0	0
Bit	15	14	13	12	11	10	9	8
Access	COUNT[15:8]							
Reset	R/W	R/W	R/W	R/W	R/W	R/W	R/W	R/W
Reset	0	0	0	0	0	0	0	0
Bit	7	6	5	4	3	2	1	0
Access	COUNT[7:0]							
Reset	R/W	R/W	R/W	R/W	R/W	R/W	R/W	R/W
Reset	0	0	0	0	0	0	0	0

#### Bits 23:0 - COUNT[23:0] Counter Value

These bits hold the value of the Counter register.

**Note:** When the TCC is configured as 16-bit timer/counter, the excess bits are read zero.

This bit field occupies the MSB of the register, [23:m]. m is dependent on the Resolution bit in the Control A register (CTRLA.RESOLUTION):

CTRLA.RESOLUTION	Bits [23:m]
0x0 - NONE	23:0 (depicted)
0x1 - DITH4	23:4
0x2 - DITH5	23:5
0x3 - DITH6	23:6

### 45.7.15 Pattern

**Name:** PATT  
**Offset:** 0x38  
**Reset:** 0x0000  
**Property:** Write-Synchronized

**Note:** This register is write-synchronized: SYNCBUSY.PATT must be checked to ensure the PATT register synchronization is complete.

Bit	15	14	13	12	11	10	9	8
	PGV7	PGV6	PGV5	PGV4	PGV3	PGV2	PGV1	PGV0
Access	R/W	R/W	R/W	R/W	R/W	R/W	R/W	R/W
Reset	0	0	0	0	0	0	0	0

Bit	7	6	5	4	3	2	1	0
	PGE7	PGE6	PGE5	PGE4	PGE3	PGE2	PGE1	PGE0
Access	R/W	R/W	R/W	R/W	R/W	R/W	R/W	R/W
Reset	0	0	0	0	0	0	0	0

#### Bits 8, 9, 10, 11, 12, 13, 14, 15 – PGV Pattern Generation Output Value

This register holds the values of pattern for each waveform output.

#### Bits 0, 1, 2, 3, 4, 5, 6, 7 – PGE Pattern Generation Output Enable

This register holds the enable status of pattern generation for each waveform output. A bit written to '1' will override the corresponding SWAP output with the corresponding PGVn value.

## 45.7.16 Waveform

**Name:** WAVE  
**Offset:** 0x3C  
**Reset:** 0x00000000  
**Property:** Write-Synchronized Bits

**Note:** This register is write-synchronized: SYNCBUSY.WAVE must be checked to ensure the WAVE register bits synchronization is complete.

Bit	31	30	29	28	27	26	25	24
					SWAP3	SWAP2	SWAP1	SWAP0
Access					R/W	R/W	R/W	R/W
Reset					0	0	0	0
Bit	23	22	21	20	19	18	17	16
			POL5	POL4	POL3	POL2	POL1	POL0
Access			R/W	R/W	R/W	R/W	R/W	R/W
Reset			0	0	0	0	0	0
Bit	15	14	13	12	11	10	9	8
					CICCEN3	CICCEN2	CICCEN1	CICCEN0
Access					R/W	R/W	R/W	R/W
Reset					0	0	0	0
Bit	7	6	5	4	3	2	1	0
	CIPEREN	RAMP[1:0]			WAVEGEN[2:0]			
Access	R/W	R/W			R/W			
Reset	0	0			0			

**Bits 24, 25, 26, 27 – SWAP** Swap DTI Output Pair x  
 Setting these bits enables output swap of DTI outputs [x] and [x+WO\_NUM/2]. Note the DTIxEN settings will not affect the swap operation.

**Bits 16, 17, 18, 19, 20, 21 – POL** Channel Polarity x  
 Setting these bits enables the output polarity in single-slope and dual-slope PWM operations.

Value	Name	Description
0	SINGLESLOPEPOL0	Compare output is initialized to ~DIR and set to DIR when TCC counter matches CCx value (single-slope PWM waveform generation).
1	SINGLESLOPEPOL1	Compare output is initialized to DIR and set to ~DIR when TCC counter matches CCx value (single-slope PWM waveform generation).
0	DUALSLOPEPOL0	Compare output is set to ~DIR when TCC counter matches CCx value (dual slope PWM waveform generation).
1	DUALSLOPEPOL1	Compare output is set to DIR when TCC counter matches CCx value (dual slope PWM waveform generation).

**Bits 8, 9, 10, 11 – CICCEN** Circular CC Enable x  
 Setting this bits enables the compare circular buffer option on the first four Compare/Capture channels. When the bit is set, CCx register value is copied-back into the CCx register on UPDATE condition.

**Bit 7 – CIPEREN** Circular Period Enable  
 Setting this bits enable the period circular buffer option. When the bit is set, the PER register value is copied-back into the PERB register on UPDATE condition.

**Bits 5:4 – RAMP[1:0]** Ramp Operation

These bits select Ramp operation (RAMP). These bits are not synchronized.

**Note:** All RAMP2 operations only support counting up mode (CTRLB.DIR = 0).

Value	Name	Description
0x0	RAMP1	RAMP1 operation
0x1	RAMP2A	Alternative RAMP2 operation
0x2	RAMP2	RAMP2 operation
0x3	RAMP2C	Critical RAMP2 operation
0x4	-	Reserved

**Bits 2:0 – WAVEGEN[2:0]** Waveform Generation Operation

These bits select the waveform generation operation. The settings impact the top value and control if frequency or PWM waveform generation should be used. These bits are not synchronized.

Value	Name	Description						
		Operation	Top	Update	Waveform Output On Match	Waveform Output On Update	OVFIF/Event Up Down	
0x0	NFRQ	Normal Frequency	PER	TOP/Zero	Toggle	Stable	TOP	Zero
0x1	MFRQ	Match Frequency	CC0	TOP/Zero	Toggle	Stable	TOP	Zero
0x2	NPWM	Normal PWM	PER	TOP/Zero	Set	Clear	TOP	Zero
0x3	Reserved	-	-	-	-	-	TOP	-
0x4	DSCRITICAL	Dual-slope PWM	PER	Zero	~DIR	Stable	-	Zero
0x5	DSBOTTOM	Dual-slope PWM	PER	Zero	~DIR	Stable	-	Zero
0x6	DSBOTH	Dual-slope PWM	PER	TOP & Zero	~DIR	Stable	TOP	Zero
0x7	DSTOP	Dual-slope PWM	PER	Zero	~DIR	Stable	TOP	-

### 45.7.17 Period Value

**Name:** PER  
**Offset:** 0x40  
**Reset:** 0xFFFFFFFF  
**Property:** Write-Synchronized

**Note:** This register is write-synchronized: SYNCBUSY.PER must be checked to ensure the PER register synchronization is complete.

Bit	31	30	29	28	27	26	25	24
Access								
Reset								
Bit	23	22	21	20	19	18	17	16
Access	PER[17:10]							
Reset	R/W	R/W	R/W	R/W	R/W	R/W	R/W	R/W
Reset	1	1	1	1	1	1	1	1
Bit	15	14	13	12	11	10	9	8
Access	PER[9:2]							
Reset	R/W	R/W	R/W	R/W	R/W	R/W	R/W	R/W
Reset	1	1	1	1	1	1	1	1
Bit	7	6	5	4	3	2	1	0
Access	PER[1:0]		DITHER[5:0]					
Reset	R/W	R/W	R/W	R/W	R/W	R/W	R/W	R/W
Reset	1	1	1	1	1	1	1	1

#### Bits 23:6 – PER[17:0] Period Value

These bits hold the value of the TCC period count.

**Note:** When the TCC is configured as 16-bit timer/counter, the excess bits are read zero.

**Note:** This bit field occupies the MSB of the register, [23:m]. m is dependent on the Resolution bit in the Control A register (CTRLA.RESOLUTION):

CTRLA.RESOLUTION	Bits [23:m]
0x0 - NONE	23:0
0x1 - DITH4	23:4
0x2 - DITH5	23:5
0x3 - DITH6	23:6 (depicted)

#### Bits 5:0 – DITHER[5:0] Dithering Cycle Number

These bits hold the number of extra cycles that are added on the PWM pulse period every 64 PWM frames.

**Note:** This bit field consists of the n LSB of the register. n is dependent on the value of the Resolution bits in the Control A register (CTRLA.RESOLUTION):

CTRLA.RESOLUTION	Bits [n:0]
0x0 - NONE	-
0x1 - DITH4	3:0
0x2 - DITH5	4:0
0x3 - DITH6	5:0 (depicted)

### 45.7.18 Compare/Capture Channel x

**Name:** CC  
**Offset:**  $0x44 + n \cdot 0x04$  [ $n=0..5$ ]  
**Reset:** 0x00000000  
**Property:** Write-Synchronized

The CCx register represents the 16-bit and 24-bit value, CCx. The register has two functions, depending on the mode of operation.

For capture operation, this register represents the second buffer level and access point for the CPU and DMA.

For compare operation, this register is continuously compared to the counter value. Normally, the output from the comparator is then used for generating waveforms.

The CCx register is updated with the buffer value from their corresponding CCBUFx register when an UPDATE condition occurs.

In addition, in match frequency operation, the CC0 register controls the counter period.

**Note:** This register is write-synchronized: SYNCBUSY.CCx must be checked to ensure the CCx register synchronization is complete.

Bit	31	30	29	28	27	26	25	24	
Access									
Reset									
Bit	23	22	21	20	19	18	17	16	
Access	R/W								
Reset	0								
Bit	15	14	13	12	11	10	9	8	
Access	R/W								
Reset	0								
Bit	7	6	5	4	3	2	1	0	
Access	R/W		R/W						R/W
Reset	0		0						0

#### Bits 23:6 – CC[17:0] Channel x Compare/Capture Value

These bits hold the value of the Channel x compare/capture register.

#### Notes:

- When the TCC is configured as a 16-bit timer/counter, the excess bits are read as zero.
- This bit field occupies the MSB of the register, [23:m]. m is dependent on the Resolution bit in the Control A register (CTRLA.RESOLUTION):

CTRLA.RESOLUTION	Bits [23:m]
0x0 - NONE	23:0
0x1 - DITH4	23:4
0x2 - DITH5	23:5
0x3 - DITH6	23:6 (depicted)

**Bits 5:0 – DITHER[5:0]** Dithering Cycle Number

These bits hold the number of extra cycles that are added on the PWM pulse width every 64 PWM frames.

**Note:** This bit field consists of the n LSB of the register. n is dependent on the value of the Resolution bits in the Control A register (CTRLA.RESOLUTION):

CTRLA.RESOLUTION	Bits [n:0]
0x0 - NONE	-
0x1 - DITH4	3:0
0x2 - DITH5	4:0
0x3 - DITH6	5:0 (depicted)

### 45.7.19 Pattern Buffer

**Name:** PATTBUF  
**Offset:** 0x64  
**Reset:** 0x0000  
**Property:** Write-Synchronized

**Note:** This register is write-synchronized: SYNCBUSY.PATT must be checked to ensure the PATT register synchronization is complete.

Bit	15	14	13	12	11	10	9	8
	PGVB7	PGVB6	PGVB5	PGVB4	PGVB3	PGVB2	PGVB1	PGVB0
Access	R/W	R/W	R/W	R/W	R/W	R/W	R/W	R/W
Reset	0	0	0	0	0	0	0	0

Bit	7	6	5	4	3	2	1	0
	PGEB7	PGEB6	PGEB5	PGEB4	PGEB3	PGEB2	PGEB1	PGEB0
Access	R/W	R/W	R/W	R/W	R/W	R/W	R/W	R/W
Reset	0	0	0	0	0	0	0	0

**Bits 8, 9, 10, 11, 12, 13, 14, 15 – PGVB** Pattern Generation Output Value Buffer

This register is the buffer for the PGV register. If double buffering is used, valid content in this register is copied to the PGV register on an UPDATE condition.

**Bits 0, 1, 2, 3, 4, 5, 6, 7 – PGEB** Pattern Generation Output Enable Buffer

This register is the buffer of the PGE register. If double buffering is used, valid content in this register is copied into the PGE register at an UPDATE condition.



## 45.7.20 Period Buffer Value

**Name:** PERBUF  
**Offset:** 0x6C  
**Reset:** 0xFFFFFFFF  
**Property:** Write-Synchronized

**Note:** This register is write-synchronized: SYNCBUSY.PER must be checked to ensure the PER register synchronization is complete.

Bit	31	30	29	28	27	26	25	24
Access								
Reset								
Bit	23	22	21	20	19	18	17	16
	PERBUF[17:10]							
Access	R/W	R/W	R/W	R/W	R/W	R/W	R/W	R/W
Reset	1	1	1	1	1	1	1	1
Bit	15	14	13	12	11	10	9	8
	PERBUF[9:2]							
Access	R/W	R/W	R/W	R/W	R/W	R/W	R/W	R/W
Reset	1	1	1	1	1	1	1	1
Bit	7	6	5	4	3	2	1	0
	PERBUF[1:0]		DITHERBUF[5:0]					
Access	R/W	R/W	R/W	R/W	R/W	R/W	R/W	R/W
Reset	1	1	1	1	1	1	1	1

### Bits 23:6 – PERBUF[17:0] Period Buffer Value

These bits hold the value of the Period Buffer register. The value is copied to PER register on UPDATE condition.

**Note:** When the TCC is configured as 16-bit timer/counter, the excess bits are read zero.

**Note:** This bit field occupies the MSB of the register, [23:m]. m is dependent on the Resolution bit in the Control A register (CTRLA.RESOLUTION):

CTRLA.RESOLUTION	Bits [23:m]
0x0 - NONE	23:0
0x1 - DITH4	23:4
0x2 - DITH5	23:5
0x3 - DITH6	23:6 (depicted)

### Bits 5:0 – DITHERBUF[5:0] Dithering Buffer Cycle Number

These bits represent the PER.DITHER bits buffer. When the double buffering is enabled, the value of this bit field is copied to the PER.DITHER bits on an UPDATE condition.

**Note:** This bit field consists of the n LSB of the register. n is dependent on the value of the Resolution bits in the Control A register (CTRLA.RESOLUTION):

CTRLA.RESOLUTION	Bits [n:0]
0x0 - NONE	-
0x1 - DITH4	3:0
0x2 - DITH5	4:0
0x3 - DITH6	5:0 (depicted)

### 45.7.21 Channel x Compare/Capture Buffer Value

**Name:** CCBUF  
**Offset:**  $0x70 + n \cdot 0x04$  [ $n=0..5$ ]  
**Reset:**  $0x00000000$   
**Property:** Write-Synchronized

CCBUF<sub>x</sub> is copied into CC<sub>x</sub> at TCC update time

**Note:** This register is write-synchronized: SYNCBUSY.CC<sub>x</sub> must be checked to ensure the CC<sub>x</sub> register synchronization is complete.

Bit	31	30	29	28	27	26	25	24
Access								
Reset								
Bit	23	22	21	20	19	18	17	16
Access	CCBUF[17:10]							
Reset	0	0	0	0	0	0	0	0
Bit	15	14	13	12	11	10	9	8
Access	CCBUF[9:2]							
Reset	0	0	0	0	0	0	0	0
Bit	7	6	5	4	3	2	1	0
Access	CCBUF[1:0]		DITHERBUF[5:0]					
Reset	0	0	0	0	0	0	0	0

#### Bits 23:6 – CCBUF[17:0] Channel x Compare/Capture Buffer Value

These bits hold the value of the Channel x Compare/Capture Buffer Value register. The register serves as the buffer for the associated compare or capture registers (CC<sub>x</sub>). Accessing this register using the CPU or DMA will affect the corresponding CCBUF<sub>Vx</sub> status bit.

#### Notes:

- When the TCC is configured as a 16-bit timer/counter, the excess bits are read as zero.
- This bit field occupies the MSB of the register, [23:m]. m is dependent on the Resolution bit in the Control A register (CTRLA.RESOLUTION):

CTRLA.RESOLUTION	Bits [23:m]
0x0 - NONE	23:0
0x1 - DITH4	23:4
0x2 - DITH5	23:5
0x3 - DITH6	23:6 (depicted)

#### Bits 5:0 – DITHERBUF[5:0] Dithering Buffer Cycle Number

These bits represent the CC<sub>x</sub>.DITHER bits buffer. When the double buffering is enable, DITHERBUF bits value is copied to the CC<sub>x</sub>.DITHER bits on an UPDATE condition.

**Note:** This bit field consists of the n LSB of the register. n is dependent on the value of the Resolution bits in the Control A register (CTRLA.RESOLUTION):

CTRLA.RESOLUTION	Bits [n:0]
0x0 - NONE	-
0x1 - DITH4	3:0
0x2 - DITH5	4:0
0x3 - DITH6	5:0 (depicted)

## 46. Advanced Encryption Standard (AES)

### 46.1 Overview

The Advanced Encryption Standard peripheral (AES) provides a means for symmetric-key encryption of 128-bit blocks, in compliance to NIST specifications.

The symmetric-key algorithm requires the same key for both encryption and decryption.

Different key sizes are supported. The key size determines the number of repetitions of transformation rounds that convert the input (called the "plaintext") into the final output ("ciphertext"). The number of rounds of repetition is as follows:

- 10 rounds of repetition for 128-bit keys
- 12 rounds of repetition for 192-bit keys
- 14 rounds of repetition for 256-bit keys

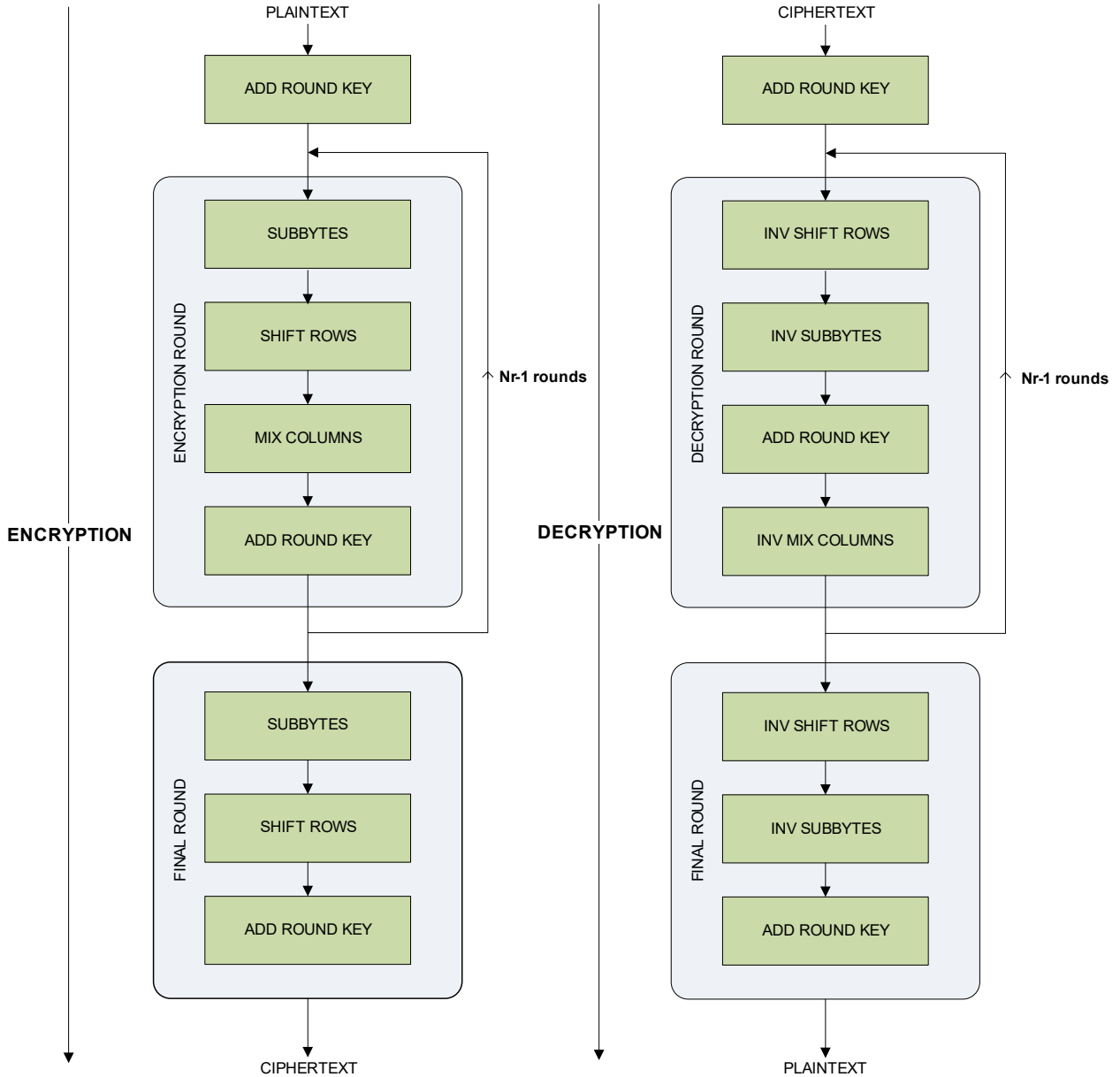
### 46.2 Features

The following are key features of the AES module:

- Compliant with FIPS Publication 197, Advanced Encryption Standard (AES)
- 128/192/256 bit cryptographic key supported
- Encryption time of 57/67/77 cycles with 128-bit/192-bit/256-bit cryptographic key
- Five confidentiality modes of operation as recommended in NIST Special Publication 800-38A
- Electronic Code Book (ECB)
- Cipher Block Chaining (CBC)
- Cipher Feedback (CFB)
- Output Feedback (OFB)
- Counter (CTR)
- Supports Counter with CBC-MAC (CCM/CCM\*) mode for authenticated encryption
- 8, 16, 32, 64, 128-bit data sizes possible in CFB mode
- Galois Counter mode (GCM) encryption and authentication

## 46.3 Block Diagram

Figure 46-1. AES Block Diagram



## 46.4 Peripheral Dependencies

<b>Peripheral Name</b>	AES – Advanced Encryption Standard
<b>Base Address</b>	0x4200_2400 (Peripheral Bus C)
<b>NVIC IRQ Index:Source</b>	130 : ENCCMP, GFMCMP
<b>MCLK APB Clock (1)</b>	CLK_AES_APB, Disabled, APBCMASK.AES
<b>GCLK Peripheral Channel Index:Clock Name</b>	n/a
<b>PAC Peripheral Identifier (PAC.WRCTRL)</b>	73
<b>DMA Trigger Index:Source (DMAC.CHCTRLAK,k=0,1,...31)</b>	81 : DMA Data Write (WR), 82 : DMA Data Read (RD)
<b>Note:</b>	
1. Clock Name, Default State, Mask Field.	

#### 46.4.1 Power Management

The AES will continue to operate in Standby sleep mode, if it's source clock is running.

The AES interrupts can be used to wake up the device from Standby sleep mode. Refer to the Power Manager chapter for details on the different sleep modes.

AES is clocked only on the following conditions:

- When the DMA is enabled.
- Whenever there is an APB access for any read and write operation to the AES registers. (Not in Standby sleep mode.)
- When the AES is enabled & encryption/decryption is ongoing.

#### 46.4.2 Clocks

The AES bus clock (CLK\_AES\_APB) can be enabled and disabled in the Main Clock module, and the default state of CLK\_AES\_APB can be found in [Peripheral Clock Masking](#). The module is fully clocked by CLK\_AES\_APB.

#### 46.4.3 DMA

The AES has two DMA request lines; one for input data, and one for output data. They are both connected to the [DMAC- Direct Memory Access Controller](#). These DMA request triggers will be acknowledged by the DMAC ACK signals. Using the AES DMA requests requires the DMA Controller to be configured first. Refer to the device DMA documentation.

#### 46.4.4 Debug Operation

When the CPU is halted in debug mode, the AES module continues normal operation. If the AES module is configured in a way that requires it to be periodically serviced by the CPU through interrupts or similar, improper operation or data loss may result during debugging. The AES module can be forced to halt operation during debugging.

#### 46.4.5 Register Access Protection

All registers with write-access are optionally write-protected by the [Peripheral Access Controller \(PAC\)](#), except the following register:

- Interrupt Flag Register (INTFLAG)

Write-protection is denoted by the Write-Protected property in the register description.

Write-protection does not apply to accesses through an external debugger. Refer to [PAC - Peripheral Access Controller](#) chapter for details.

### 46.5 Functional Description

#### 46.5.1 Principle of Operation

The following is a high level description of the algorithm. These are the steps:

- KeyExpansion: Round keys are derived from the cipher key using Rijndael's key schedule.
- InitialRound:
  - AddRoundKey: Each byte of the state is combined with the round key using bitwise XOR.
- Rounds:
  - SubBytes: A non-linear substitution step where each byte is replaced with another according to a lookup table.
  - ShiftRows: A transposition step where each row of the state is shifted cyclically a certain number of steps.

- MixColumns: A mixing operation which operates on the columns of the state, combining the four bytes in each column.
- AddRoundKey
- Final Round (no MixColumns):
  - SubBytes
  - ShiftRows
  - AddRoundKey

The relationship between the module's clock frequency and throughput (in bytes per second) is given by:

Clock Frequency = (Throughput/2) x (Nr+1) for 2 byte parallel processing

Clock Frequency = (Throughput/4) x (Nr+1) for 4 byte parallel processing

where Nr is the number of rounds, depending on the key length.

## 46.5.2 Basic Operation

### 46.5.2.1 Initialization

The following register is enable-protected:

- Control A (CTRLA)

Enable-protection is denoted by the Enable-Protected property in the register description.

### 46.5.2.2 Enabling, Disabling, and Resetting

The AES module is enabled by writing a one to the Enable bit in the Control A register (CTRLA.ENABLE). The module is disabled by writing a zero to CTRLA.ENABLE. The module is reset by writing a one to the Software Reset bit in the Control A register (CTRLA.SWRST).

### 46.5.2.3 Basic Programming

The CIPHER bit in the Control A Register (CTRLA.CIPHER) allows selection between the encryption and the decryption processes. The AES is capable of using cryptographic keys of 128/192/256 bits to encrypt and decrypt data in blocks of 128 bits. The Key Size (128/192/256) can be programmed in the KEYSIZE field in the Control A Register (CTRLA.KEYSIZE). This 128-bit/192-bit/256-bit key is defined in the Key Word Registers (KEYWORD). By setting the XORKEY bit of CTRLA register, keyword can be updated with the resulting XOR value of user keyword and previous keyword content.

The input data for processing is written to a data buffer consisting of four 32-bit registers through the Data register address. The data buffer register (note that input and output data shares the same data buffer register) that is written to when the next write is performed is indicated by the Data Pointer in the Data Buffer Pointer (DATABUFPTR) register. This field is incremented by one or wrapped by hardware when a write to the INDATA register address is performed. This field can also be programmed, allowing the user direct control over which input buffer register to write. Note that when AES module is in the CFB operation mode with the data segment size less than 128 bits, the input data must be written to the first (DATABUFPTR = 0) and second (DATABUFPTR = 1) input buffer registers.

The input to the encryption processes of the CBC, CFB and OFB modes includes, in addition to the plaintext, a 128-bit data block called the Initialization Vector (IV), which must be set in the Initialization Vector Registers (INTVECT). Additionally, the GCM mode 128-bit authentication data needs to be programmed. The Initialization Vector is used in the initial step in the encryption of a message and in the corresponding decryption of the message. The Initialization Vector Registers are also used by the Counter mode to set the counter value.

It is necessary to notify AES module whenever the next data block it is going to process is the beginning of a new message. This is done by writing a one to the New Message bit in the Control B register (CTRLB.NEWMSG).

The AES modes of operation are selected by setting the AESMODE field in the Control A Register (CTRLA.AESMODE). In Cipher Feedback Mode (CFB), five data sizes are possible (8, 16, 32, 64 or 128 bits), configurable by means of the CFBS field in the Control A Register (CTRLA.CFBS). In Counter mode, the size of the block counter embedded in the module is 16 bits. Therefore, there is a rollover after processing 1 megabyte of data. The data pre-processing, post-processing and data chaining for the concerned modes are automatically performed by the module.

When data processing has completed, the Encryption Complete bit in the Interrupt Flag register (INTFLAG.ENCCMP) is set by hardware (which triggers an interrupt request if the corresponding interrupt is enabled). The processed output data is read out through the Output Data register (INDATA) address from the data buffer consisting of four 32-bit registers. The data buffer register that is read when the next read is performed is indicated by the Data Pointer field in the Data Buffer Pointer register (DATABUFPTR). This field is incremented by one or wrapped by hardware when a read from the INDATA register address is performed. This field can be programmed, giving the user direct control over which output buffer register to read from. Note that when AES module is in the CFB operation mode with the data segment size less than 128 bits, the output data must be read from the first (DATABUFPTR = 0) and second (DATABUFPTR = 1) output buffer registers as shown in the following table. The Encryption Complete bit (INTFLAG.ENCCMP) is cleared by hardware after the processed data has been read from the relevant output buffer registers.

**Table 46-1.** Relevant Input/Output Data Registers for Different Confidentiality Modes

Confidentiality Mode	Relevant Input / Output Data Registers
ECB	All
CBC	All
OFB	All
128-bit CFB	All
64-bit CFB	First and Second
32-bit CFB	First
16-bit CFB	First
8-bit CFB	First
CTR	All

#### 46.5.2.4 Start Modes

The Start mode field in the Control A Register (CTRLA.STARTMODE) allows the selection of encryption start mode.

##### 1. Manual Start Mode

In the Manual Start Mode the sequence is as follows:

- a. Write the 128/192/256 bit key in the Key Register (KEYWORD)
- b. Write the initialization vector or counter in the Initialization Vector Register (INTVECT). The initialization vector concerns all modes except ECB
- c. Enable interrupts in Interrupt Enable Set Register (INTENSET), depending on whether an interrupt is required or not at the end of processing.
- d. Write the data to be encrypted or decrypted in the Data Registers (INDATA).
- e. Set the START bit in Control B Register (CTRLB.START) to begin the encryption or the decryption process.
- f. When the processing completes, the Encryption Complete bit in the Interrupt Flag Register (INTFLAG.ENCCMP) raises. If Encryption Complete interrupt has been enabled, the interrupt line of the AES is activated.
- g. When the software reads one of the Output Data Registers (INDATA), INTFLAG.ENCCMP bit is automatically cleared.

##### 2. Auto start Mode



The Auto Start Mode is similar to the manual one, but as soon as the correct number of input data registers is written, processing is automatically started without setting the START bit in the Control B Register. DMA operation uses this mode.

### 3. Last Output Data Mode (LOD)

This mode is used to generate message authentication code (MAC) on data in CCM mode of operation. The CCM mode combines counter mode for encryption and CBC-MAC generation for authentication.

When LOD is disabled in CCM mode then counter mode of encryption is performed on the input data block.

When LOD is enabled in CCM mode then CBC-MAC generation is performed. Zero block is used as the initialization vector by the hardware. Reading from the Output Data Register (INDATA) is not required to clear the ENCCMP flag. The ENCCMP flag is automatically cleared by writing into the Input Data Register (INDATA). This allows retrieval of only the last data in several encryption/decryption processes. No output data register reads are necessary between each block of encryption/decryption process.

Note that assembling message depending on the security level identifier in CCM\* has to be done in software.

#### 46.5.2.5 Computation of last $N_k$ words of expanded key

The AES algorithm takes the cryptographic key provided by the user and performs a Key Expansion routine to generate an expanded key. The expanded key contains a total of  $4(N_r + 1)$  32-bit words, where the first  $N_k$  (4/6/8 for a 128-/192-/256-bit key) words are the user-provided key. For data encryption, the expanded key is used in the forward direction, i.e., the first four words are used in the initial round of data processing, the second four words in the first round, the third four words in the second round, and so on. On the other hand, for data decryption, the expanded key is used in the reverse direction, i.e., the last four words are used in the initial round of data processing, the last second four words in the first round, the last third four words in the second round, and so on.

To reduce gate count, the AES module does not generate and store the entire expanded key prior to data processing. Instead, it computes on-the-fly the round key (four 32-bit words) required for the current round of data processing. In general, the round key for the current round of data processing can be computed from the  $N_k$  words of the expanded key generated in the previous rounds. When AES module is operating in the encryption mode, the round key for the initial round of data processing is simply the user-provided key written to the KEY registers. On the other hand, when AES module is operating in the decryption mode, the round key for the initial round of data processing is the last four words of the expanded key, which is not available unless AES module has performed at least one encryption process prior to operating in the decryption mode.

In general, the last  $N_k$  words of the expanded key must be available before decryption can start. If desired, AES module can be instructed to compute the last  $N_k$  words of the expanded key in advance by writing a one to the Key Generate (KEYGEN) bit in the CTRLA register (CTRLA.KEYGEN). The computation takes  $N_r$  clock cycles. Alternatively, the last  $N_k$  words of the expanded key can be automatically computed by AES module when a decryption process is initiated if they have not been computed in advance or have become invalid. Note that this will introduce a latency of  $N_r$  clock cycles to the first decryption process.

#### 46.5.2.6 Hardware Countermeasures against Differential Power Analysis Attacks

The AES module features four types of hardware countermeasures that are useful for protecting data against differential power analysis attacks:

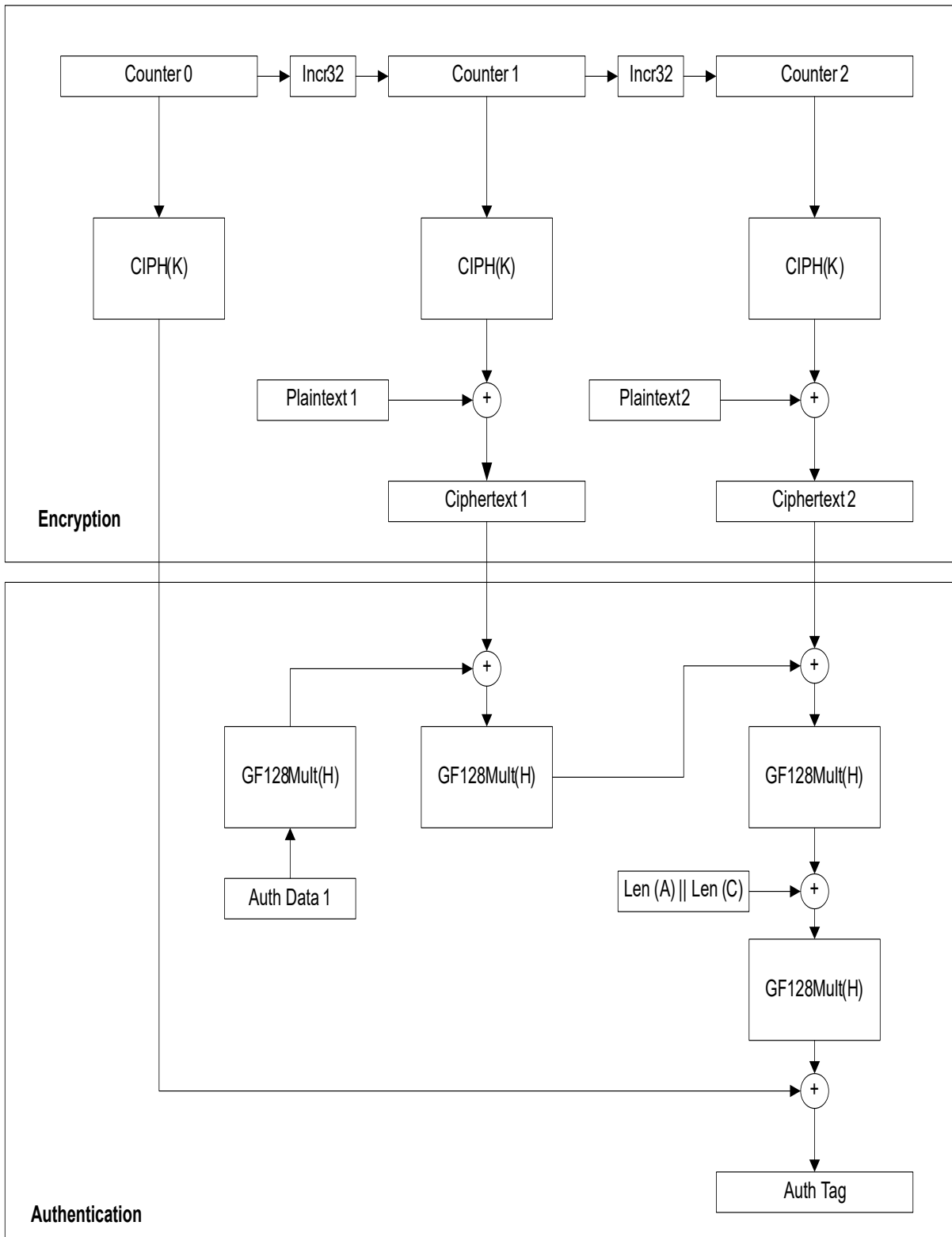
- Type 1: Randomly add one cycle to data processing
- Type 2: Randomly add one cycle to data processing (other version)
- Type 3: Add a random number of clock cycles to data processing, subject to a maximum of 11/13/15 clock cycles for key sizes of 128/192/256 bits

- Type 4: Add random spurious power consumption during data processing

By default, all countermeasures are enabled, but require a write in DRNGSEED register to be effective. One or more of the countermeasures can be disabled by programming the Countermeasure Type field in the Control A (CTRLA.CTYPE) register. The countermeasures use random numbers generated by a deterministic random number generator embedded in AES module. The seed for the random number generator is written to the RANDSEED register. Note also that a new seed must be written after a change in the keysize. Note that enabling countermeasures reduces AES module's throughput. In short, the throughput is highest with all the countermeasures disabled. On the other hand, with all of the countermeasures enabled, the best protection is achieved but the throughput is worst.

### 46.5.3 Galois Counter Mode (GCM)

GCM is comprised of the AES engine in CTR mode along with a universal hash function (GHASH engine) that is defined over a binary Galois field to produce a message authentication tag. The GHASH engine processes data packets after the AES operation. GCM provides assurance of the confidentiality of data through the AES Counter mode of operation for encryption. Authenticity of the confidential data is assured through the GHASH engine. Refer to the NIST Special Publication 800-38D Recommendation for more information.



### 46.5.3.1 GCM Operation

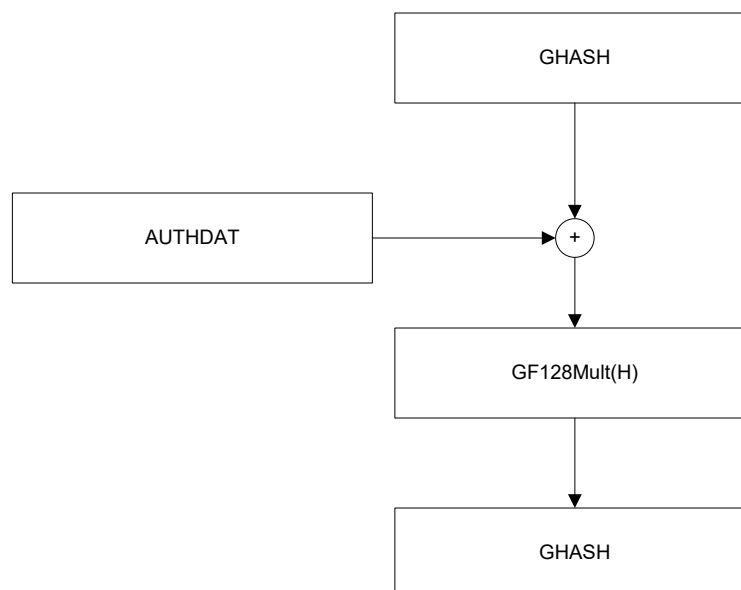
#### 46.5.3.1.1 Hashkey Generation

- Configure CTRLA register as follows:
  - a. CTRLA.STARTMODE as Manual (Auto for DMAC)

- b. CTRLA.CIPHER as Encryption
- c. CTRLA.KEYSIZE as per the key used
- d. CTRLA.AESMODE as ECB
- e. CTRLA.CTYPE as per the countermeasures required.
- Set CTRLA.ENABLE
- Write zero to CIPLN reg.
- Write the key in KEYWORD register
- Write the zeros to INDATA reg
- Set CTRLB.Start.
- Wait for INTFLAG.ENCCMP to be set
- AES Hardware generates Hash Subkey in HASHKEY register.

#### 46.5.3.1.2 Authentication Header Processing

- Configure CTRLA register as follows:
    - a. CTRLA.STARTMODE as Manual
    - b. CTRLA.CIPHER as Encryption
    - c. CTRLA.KEYSIZE as per the key used
    - d. CTRLA.AESMODE as GCM
    - e. CTRLA.CTYPE as per the countermeasures required.
  - Set CTRLA.ENABLE
  - Write the key in KEYWORD register
  - Set CTRLB.GFMUL
  - Write the Authdata to INDATA reg
  - Set CTRLB.START as 1
  - Wait for INTFLAG.GFMCMP to be set.
  - AES Hardware generates output in GHASH register
  - Continue steps 4 to 7 for remaining Authentication Header.
- Note: If the Auth data is less than 128 bit, it has to be padded with zero to make it 128 bit aligned.



#### 46.5.3.1.3 Plain text Processing

- Set CTRLB.NEWMMSG for the new set of plain text processing.
- Load CIPLN reg.
- Load (J0+1) in INTVECT register.
- As described in NIST documentation  $J_0 = IV \parallel 0_{31} \parallel 1$  when  $\text{len}(IV)=96$  and  $J_0 = \text{GHASH}_H(IV \parallel 0_{s+64} \parallel [\text{len}(IV)]_{64})$  (s is the minimum number of zeroes that should be padded with the Initialization Vector to make it a multiple of 128) if  $\text{len}(IV) \neq 96$ .
- Load plain text in INDATA register.
- Set CTRLB.START as 1.
- Wait for INTFLAG.ENCCMP to be set.
- AES Hardware generates output in INDATA register.
- Intermediate GHASH is stored in GHASH register and Cipher Text available in INDATA register.
- Continue 3 to 6 till the input of plain text to get the cipher text and the Hash keys.
- At the last input, set CTRLB.EOM.
- Write last in-data to INDATA reg.
- Set CTRLB.START as 1.
- Wait for INTFLAG.ENCCMP to be set.
- AES Hardware generates output in INDATA register and final Hash key in GHASH register.
- Load  $[\text{LEN}(A)]_{64} \parallel [\text{LEN}(C)]_{64}$  in INDATA register and set CTRLB.GFMUL and CTRLB.START as 1.
- Wait for INTFLAG.GFMCMP to be set.
- AES Hardware generates final GHASH value in GHASH register.

#### 46.5.3.1.4 Plain text processing with DMAC

- Set CTRLB.NEWMMSG for the new set of plain text processing.
- Load CIPLN reg.
- Load (J0+1) in INTVECT register.
- Load plain text in INDATA register.
- Wait for INTFLAG.ENCCMP to be set.
- AES Hardware generates output in INDATA register.
- Intermediate GHASH is stored in GHASH register and Cipher Text available in INDATA register.
- Continue 3 to 5 till the input of plain text to get the cipher text and the Hash keys.
- At the last input, set CTRLB.EOM.
- Write last in-data to INDATA reg.
- Wait for INTFLAG.ENCCMP to be set.
- AES Hardware generates output in INDATA register and final Hash key in GHASH register.
- Load  $[\text{LEN}(A)]_{64} \parallel [\text{LEN}(C)]_{64}$  in INDATA register and set CTRLB.GFMUL and CTRLB.START as 1.
- Wait for INTFLAG.GFMCMP to be set.
- AES Hardware generates final GHASH value in GHASH register.

#### 46.5.3.1.5 Tag Generation

- Configure CTRLA
  - a. Set CTRLA.ENABLE to 0
  - b. Set CTRLA.AESMODE as CTR

- c. Set CTRLA.ENABLE to 1
- Load J0 value to INITVECTV reg.
- Load GHASH value to INDATA reg.
- Set CTRLB.NEWMMSG and CTRLB.START to start the Counter mode operation.
- Wait for INTFLAG.ENCCMP to be set.
- AES Hardware generates the GCM Tag output in INDATA register.

## 46.6 Register Summary

Offset	Name	Bit Pos.	7	6	5	4	3	2	1	0
0x00	CTRLA	7:0		CFBS[2:0]			AESMODE[2:0]		ENABLE	SWRST
		15:8		XORKEY	KEYGEN	LOD	STARTMODE	CIPHER	KEYSIZE[1:0]	
		23:16					CTYPE4	CTYPE3	CTYPE2	CTYPE1
		31:24								
0x04	CTRLB	7:0				GFMUL	EOM	NEWMSG	START	
0x05	INTENCLR	7:0						GFMCMP	ENCCMP	
0x06	INTENSET	7:0						GFMCMP	ENCCMP	
0x07	INTFLAG	7:0						GFMCMP	ENCCMP	
0x08	DATABUFPTR	7:0						INDATAPTR[1:0]		
0x09	DBGCTRL	7:0							DBGRUN	
0x0A ... 0x0B	Reserved									
0x0C	KEYWORD0	7:0					KEYWORD[7:0]			
		15:8					KEYWORD[15:8]			
		23:16					KEYWORD[23:16]			
		31:24					KEYWORD[31:24]			
0x10	KEYWORD1	7:0					KEYWORD[7:0]			
		15:8					KEYWORD[15:8]			
		23:16					KEYWORD[23:16]			
		31:24					KEYWORD[31:24]			
0x14	KEYWORD2	7:0					KEYWORD[7:0]			
		15:8					KEYWORD[15:8]			
		23:16					KEYWORD[23:16]			
		31:24					KEYWORD[31:24]			
0x18	KEYWORD3	7:0					KEYWORD[7:0]			
		15:8					KEYWORD[15:8]			
		23:16					KEYWORD[23:16]			
		31:24					KEYWORD[31:24]			
0x1C	KEYWORD4	7:0					KEYWORD[7:0]			
		15:8					KEYWORD[15:8]			
		23:16					KEYWORD[23:16]			
		31:24					KEYWORD[31:24]			
0x20	KEYWORD5	7:0					KEYWORD[7:0]			
		15:8					KEYWORD[15:8]			
		23:16					KEYWORD[23:16]			
		31:24					KEYWORD[31:24]			
0x24	KEYWORD6	7:0					KEYWORD[7:0]			
		15:8					KEYWORD[15:8]			
		23:16					KEYWORD[23:16]			
		31:24					KEYWORD[31:24]			
0x28	KEYWORD7	7:0					KEYWORD[7:0]			
		15:8					KEYWORD[15:8]			
		23:16					KEYWORD[23:16]			
		31:24					KEYWORD[31:24]			
0x2C ... 0x37	Reserved									
0x38	INDATA	7:0					INDATA[7:0]			
		15:8					INDATA[15:8]			
		23:16					INDATA[23:16]			
		31:24					INDATA[31:24]			
0x3C	INTVECTV0	7:0					INTVECTV[7:0]			
		15:8					INTVECTV[15:8]			
		23:16					INTVECTV[23:16]			
		31:24					INTVECTV[31:24]			

.....continued

Offset	Name	Bit Pos.	7	6	5	4	3	2	1	0
0x40	INTVECTV1	7:0	INTVECTV[7:0]							
		15:8	INTVECTV[15:8]							
		23:16	INTVECTV[23:16]							
		31:24	INTVECTV[31:24]							
0x44	INTVECTV2	7:0	INTVECTV[7:0]							
		15:8	INTVECTV[15:8]							
		23:16	INTVECTV[23:16]							
		31:24	INTVECTV[31:24]							
0x48	INTVECTV3	7:0	INTVECTV[7:0]							
		15:8	INTVECTV[15:8]							
		23:16	INTVECTV[23:16]							
		31:24	INTVECTV[31:24]							
0x4C ... 0x5B	Reserved									
0x5C	HASHKEY0	7:0	HASHKEY[7:0]							
		15:8	HASHKEY[15:8]							
		23:16	HASHKEY[23:16]							
		31:24	HASHKEY[31:24]							
0x60	HASHKEY1	7:0	HASHKEY[7:0]							
		15:8	HASHKEY[15:8]							
		23:16	HASHKEY[23:16]							
		31:24	HASHKEY[31:24]							
0x64	HASHKEY2	7:0	HASHKEY[7:0]							
		15:8	HASHKEY[15:8]							
		23:16	HASHKEY[23:16]							
		31:24	HASHKEY[31:24]							
0x68	HASHKEY3	7:0	HASHKEY[7:0]							
		15:8	HASHKEY[15:8]							
		23:16	HASHKEY[23:16]							
		31:24	HASHKEY[31:24]							
0x6C	GHASH0	7:0	GHASH[7:0]							
		15:8	GHASH[15:8]							
		23:16	GHASH[23:16]							
		31:24	GHASH[31:24]							
0x70	GHASH1	7:0	GHASH[7:0]							
		15:8	GHASH[15:8]							
		23:16	GHASH[23:16]							
		31:24	GHASH[31:24]							
0x74	GHASH2	7:0	GHASH[7:0]							
		15:8	GHASH[15:8]							
		23:16	GHASH[23:16]							
		31:24	GHASH[31:24]							
0x78	GHASH3	7:0	GHASH[7:0]							
		15:8	GHASH[15:8]							
		23:16	GHASH[23:16]							
		31:24	GHASH[31:24]							
0x7C ... 0x7F	Reserved									
0x80	CIPLN	7:0	CIPLN[7:0]							
		15:8	CIPLN[15:8]							
		23:16	CIPLN[23:16]							
		31:24	CIPLN[31:24]							
0x84	RANDSEED	7:0	RANDSEED[7:0]							
		15:8	RANDSEED[15:8]							
		23:16	RANDSEED[23:16]							
		31:24	RANDSEED[31:24]							



## 46.6.1 Control A

**Name:** CTRLA  
**Offset:** 0x00  
**Reset:** 0x00000000  
**Property:** PAC Write-Protection, Enable-protected

Bit	31	30	29	28	27	26	25	24
Access								
Reset								
Bit	23	22	21	20	19	18	17	16
Access					CTYPE4	CTYPE3	CTYPE2	CTYPE1
Reset					R/W 0	R/W 0	R/W 0	R/W 0
Bit	15	14	13	12	11	10	9	8
Access		XORKEY	KEYGEN	LOD	STARTMODE	CIPHER	KEYSIZE[1:0]	
Reset		R/W 0	R/W 0	R/W 0	R/W 0	R/W 0	R/W 0	R/W 0
Bit	7	6	5	4	3	2	1	0
Access	CFBS[2:0]			AESMODE[2:0]			ENABLE	SWRST
Reset	R/W 0	R/W 0	R/W 0	R/W 0	R/W 0	R/W 0	R/W 0	R/W 0

### Bits 16, 17, 18, 19 – CTYPE<sub>x</sub> Counter Measure Type x, x = 1..4

Value	Description
0	Countermeasure x is disabled
1	Countermeasure x is enabled

### Bit 14 – XORKEY XOR Key Operation

Value	Description
0	No effect
1	The user keyword gets XORed with the previous keyword register content.

### Bit 13 – KEYGEN Last Key Generation

Value	Description
0	No effect
1	Start Computation of the last NK words of the expanded key

### Bit 12 – LOD Last Output Data Mode

Value	Description
0	No effect
1	Start encryption in Last Output Data mode

### Bit 11 – STARTMODE Start Mode Select

Value	Name	Description
0	MANUAL	Start Encryption / Decryption in Manual mode
1	AUTO	Start Encryption / Decryption in Auto mode

### Bit 10 – CIPHER Cipher Mode Select

Value	Description
0	Decryption
1	Encryption

**Bits 9:8 – KEYSIZE[1:0]** Encryption Key Size

Value	Name	Description
0	128BIT	128-bit Key for Encryption / Decryption
1	192BIT	192-bit Key for Encryption / Decryption
2	256BIT	256-bit Key for Encryption / Decryption
3	Reserved	Reserved

**Bits 7:5 – CFBS[2:0]** Cipher Feedback Block Size

Value	Name	Description
0	128BIT	128-bit Input data block for Encryption/Decryption in Cipher Feedback mode
1	64BIT	64-bit Input data block for Encryption/Decryption in Cipher Feedback mode
2	32BIT	32-bit Input data block for Encryption/Decryption in Cipher Feedback mode
3	16BIT	16-bit Input data block for Encryption/Decryption in Cipher Feedback mode
4	8BIT	8-bit Input data block for Encryption/Decryption in Cipher Feedback mode
5–7	Reserved	Reserved

**Bits 4:2 – AESMODE[2:0]** AES Modes of Operation

Value	Name	Description
0	ECB	Electronic code book mode
1	CBC	Cipher block chaining mode
2	OFB	Output feedback mode
3	CFB	Cipher feedback mode
4	Counter	Counter mode
5	CCM	CCM mode
6	GCM	Galois counter mode
7	Reserved	Reserved

**Bit 1 – ENABLE** Enable

Value	Description
0	The peripheral is disabled
1	The peripheral is enabled

**Bit 0 – SWRST** Software Reset

Writing a '0' to this bit has no effect.

Writing a '1' to this bit resets all registers in the AES module to their initial state, and the module will be disabled.

Writing a '1' to **SWRST** will always take precedence, meaning that all other writes in the same write operation will be discarded.

Value	Description
0	There is no reset operation ongoing
1	The reset operation is ongoing

## 46.6.2 Control B

**Name:** CTRLB  
**Offset:** 0x04  
**Reset:** 0x00  
**Property:** PAC Write-Protection

Bit	7	6	5	4	3	2	1	0
					GFMUL	EOM	NEWMSG	START
Access					R/W	R/W	R/W	R/W
Reset					0	0	0	0

### Bit 3 - GFMUL GF Multiplication

This bit is applicable only to GCM mode.

Value	Description
0	No action
1	Setting this bit calculates GF multiplication with data buffer content and hashkey register content.

### Bit 2 - EOM End of Message

This bit is applicable only to GCM mode.

Value	Description
0	No action
1	Setting this bit generates final GHASH value for the message.

### Bit 1 - NEWMSG New Message

This bit is used in cipher block chaining (CBC), cipher feedback (CFB) and output feedback (OFB), counter (CTR) modes to indicate the hardware to use Initialization vector for encrypting the first block of message.

Value	Description
0	No action
1	Setting this bit indicates start of new message to the module.

### Bit 0 - START Start Encryption/Decryption

Value	Description
0	No action
1	Start encryption / decryption in manual mode.

### 46.6.3 Interrupt Enable Clear

**Name:** INTENCLR  
**Offset:** 0x05  
**Reset:** 0x00  
**Property:** PAC Write-Protection

This register allows the user to disable an interrupt without doing a read-modify-write operation. Changes in this register will also be reflected in the Interrupt Enable Set (INTENSET) register.

Bit	7	6	5	4	3	2	1	0
							GFMCMP	ENCCMP
Access							R/W	R/W
Reset							0	0

#### Bit 1 – GFMCMP GF Multiplication Complete Interrupt Enable

Writing a '0' to this bit has no effect.

Writing a '1' to this bit will clear the GF Multiplication Complete Interrupt Enable bit, which disables the GF Multiplication Complete interrupt.

Value	Description
0	The GF Multiplication Complete interrupt is disabled.
1	The GF Multiplication Complete interrupt is enabled.

#### Bit 0 – ENCCMP Encryption Complete Interrupt Enable

Writing a '0' to this bit has no effect.

Writing a '1' to this bit will clear the Encryption Complete Interrupt Enable bit, which disables the Encryption Complete interrupt.

Value	Description
0	The Encryption Complete interrupt is disabled.
1	The Encryption Complete interrupt is enabled.

#### 46.6.4 Interrupt Enable Set

**Name:** INTENSET  
**Offset:** 0x06  
**Reset:** 0x00  
**Property:** PAC Write-Protection

This register allows the user to enable an interrupt without doing a read-modify-write operation. Changes in this register will also be reflected in the Interrupt Enable Clear (INTENCLR) register.

Bit	7	6	5	4	3	2	1	0
							GFMCMP	ENCCMP
Access							R/W	R/W
Reset							0	0

##### Bit 1 - GFMCMP GF Multiplication Complete Interrupt Enable

Writing a '0' to this bit has no effect. Writing a '1' to this bit will clear the GF Multiplication Complete Interrupt Enable bit, which enables the GF Multiplication Complete interrupt.

Value	Description
0	The GF Multiplication Complete interrupt is disabled.
1	The GF Multiplication Complete interrupt is enabled.

##### Bit 0 - ENCCMP Encryption Complete Interrupt Enable

Writing a '0' to this bit has no effect. Writing a '1' to this bit will clear the Encryption Complete Interrupt Enable bit, which enables the Encryption Complete interrupt.

Value	Description
0	The Encryption Complete interrupt is disabled.
1	The Encryption Complete interrupt is enabled.

## 46.6.5 Interrupt Flag Status and Clear

**Name:** INTFLAG  
**Offset:** 0x07  
**Reset:** 0x00

Bit	7	6	5	4	3	2	1	0
							GFMCMP	ENCCMP
Access							R/W	R/W
Reset							0	0

### Bit 1 – GFMCMP GF Multiplication Complete

This flag is cleared by writing a '1' to it.

This flag is set when GHASH value is available on the Galois Hash Registers (GHASH<sub>x</sub>) in GCM mode.

Writing a '0' to this bit has no effect.

This flag is also automatically cleared in the following cases.

1. Manual encryption/decryption occurs (START in CTRLB register).
2. Reading from the GHASH<sub>x</sub> register.

### Bit 0 – ENCCMP Encryption Complete

This flag is cleared by writing a '1' to it.

This flag is set when encryption/decryption is complete and valid data is available on the Data Register.

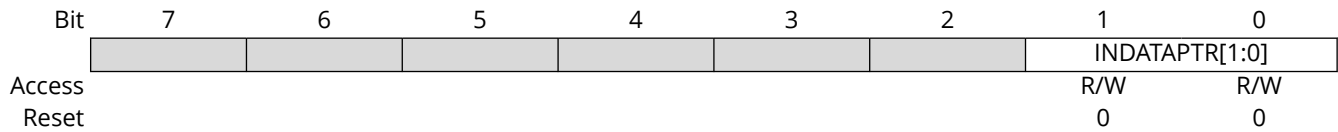
Writing a '0' to this bit has no effect.

This flag is also automatically cleared in the following cases:

1. Manual encryption/decryption occurs (START in CTRLA register). (This feature is needed only if we do not support double buffering of INDATA registers).
2. Reading from the data register (INDATA<sub>x</sub>) when LOD = 0.
3. Writing into the data register (INDATA<sub>x</sub>) when LOD = 1.
4. Reading from the Hash Key register (HASHKEY<sub>x</sub>).

### 46.6.6 Data Buffer Pointer

**Name:** DATABUFPTR  
**Offset:** 0x08  
**Reset:** 0x00  
**Property:** PAC Write-Protection

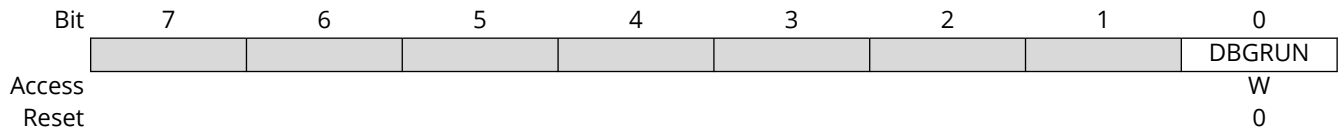


#### Bits 1:0 – INDATAPTR[1:0] Input Data Pointer

Writing to this field changes the value of the input data pointer, which determines which of the four data registers is written to/read from when the next write/read to the `INDATA` register address is performed.

### 46.6.7 Debug

**Name:** DBGCTRL  
**Offset:** 0x09  
**Reset:** 0x00  
**Property:** PAC Write-Protection



#### Bit 0 - DBGRUN Debug Run

Writing a '0' to this bit causes the AES to halt during debug mode.

Writing a '1' to this bit allows the AES to continue normal operation during debug mode. This bit can only be changed while the AES is disabled.



## 46.6.8 Keyword

**Name:** KEYWORD  
**Offset:** 0x0C + n\*0x04 [n=0..7]  
**Reset:** 0x00000000  
**Property:** PAC Write-Protection

Bit	31	30	29	28	27	26	25	24
	KEYWORD[31:24]							
Access	W	W	W	W	W	W	W	W
Reset	0	0	0	0	0	0	0	0
Bit	23	22	21	20	19	18	17	16
	KEYWORD[23:16]							
Access	W	W	W	W	W	W	W	W
Reset	0	0	0	0	0	0	0	0
Bit	15	14	13	12	11	10	9	8
	KEYWORD[15:8]							
Access	W	W	W	W	W	W	W	W
Reset	0	0	0	0	0	0	0	0
Bit	7	6	5	4	3	2	1	0
	KEYWORD[7:0]							
Access	W	W	W	W	W	W	W	W
Reset	0	0	0	0	0	0	0	0

### Bits 31:0 – KEYWORD[31:0] Key Word Value

The four/six/eight 32-bit Key Word registers set the 128-bit/192-bit/256-bit cryptographic key used for encryption/decryption. KEYWORD0 .KEYWORD corresponds to the first word of the key and KEYWORD3/KEYWORD5/KEYWORD7 .KEYWORD to the last one.

**Note:** By setting the XORKEY bit of CTRLA register, keyword will update with the resulting XOR value of user keyword and previous keyword content.

## 46.6.9 Data

**Name:** INDATA  
**Offset:** 0x38  
**Reset:** 0x00000000

Bit	31	30	29	28	27	26	25	24
	INDATA[31:24]							
Access	R/W	R/W	R/W	R/W	R/W	R/W	R/W	R/W
Reset	0	0	0	0	0	0	0	0
Bit	23	22	21	20	19	18	17	16
	INDATA[23:16]							
Access	R/W	R/W	R/W	R/W	R/W	R/W	R/W	R/W
Reset	0	0	0	0	0	0	0	0
Bit	15	14	13	12	11	10	9	8
	INDATA[15:8]							
Access	R/W	R/W	R/W	R/W	R/W	R/W	R/W	R/W
Reset	0	0	0	0	0	0	0	0
Bit	7	6	5	4	3	2	1	0
	INDATA[7:0]							
Access	R/W	R/W	R/W	R/W	R/W	R/W	R/W	R/W
Reset	0	0	0	0	0	0	0	0

### Bits 31:0 – INDATA[31:0] Data Value

A write to or read from this register corresponds to a write to or read from one of the four data registers. The four 32-bit Data registers set the 128-bit data block used for encryption/decryption. The data register that is written to or read from is given by the `DATABUFPTR.INDATPTR` field.

**Note:** Both input and output shares the same data buffer. Reading INDATA register will return 0's when AES is performing encryption or decryption operation.

## 46.6.10 Initialization Vector Register

**Name:** INTVECTV  
**Offset:** 0x3C + n\*0x04 [n=0..3]  
**Reset:** 0x00000000  
**Property:** PAC Write-Protection

Bit	31	30	29	28	27	26	25	24
	INTVECTV[31:24]							
Access	W	W	W	W	W	W	W	W
Reset	0	0	0	0	0	0	0	0
Bit	23	22	21	20	19	18	17	16
	INTVECTV[23:16]							
Access	W	W	W	W	W	W	W	W
Reset	0	0	0	0	0	0	0	0
Bit	15	14	13	12	11	10	9	8
	INTVECTV[15:8]							
Access	W	W	W	W	W	W	W	W
Reset	0	0	0	0	0	0	0	0
Bit	7	6	5	4	3	2	1	0
	INTVECTV[7:0]							
Access	W	W	W	W	W	W	W	W
Reset	0	0	0	0	0	0	0	0

### Bits 31:0 – INTVECTV[31:0] Initialization Vector Value

The four 32-bit Initialization Vector registers  $INTVECTV_n$  set the 128-bit Initialization Vector data block that is used by some modes of operation as an additional initial input.  $INTVECTV_0$  .  $INTVECTV$  corresponds to the first word of the Initialization Vector,  $INTVECTV_3$  .  $INTVECTV$  to the last one. These registers are write-only to prevent the Initialization Vector from being read by another application. For CBC, OFB, and CFB modes, the Initialization Vector corresponds to the initialization vector. For CTR mode, it corresponds to the counter value.

### 46.6.11 Hash Key (GCM mode only)

**Name:** HASHKEY  
**Offset:** 0x5C + n\*0x04 [n=0..3]  
**Reset:** 0x00000000  
**Property:** PAC Write-protection

Bit	31	30	29	28	27	26	25	24
	HASHKEY[31:24]							
Access	R/W	R/W	R/W	R/W	R/W	R/W	R/W	R/W
Reset	0	0	0	0	0	0	0	0
Bit	23	22	21	20	19	18	17	16
	HASHKEY[23:16]							
Access	R/W	R/W	R/W	R/W	R/W	R/W	R/W	R/W
Reset	0	0	0	0	0	0	0	0
Bit	15	14	13	12	11	10	9	8
	HASHKEY[15:8]							
Access	R/W	R/W	R/W	R/W	R/W	R/W	R/W	R/W
Reset	0	0	0	0	0	0	0	0
Bit	7	6	5	4	3	2	1	0
	HASHKEY[7:0]							
Access	R/W	R/W	R/W	R/W	R/W	R/W	R/W	R/W
Reset	0	0	0	0	0	0	0	0

#### Bits 31:0 – HASHKEY[31:0] Hash Key Value

The four 32-bit HASHKEY registers contain the 128-bit Hash Key value computed from the AES KEY. The Hash Key value can also be programmed offering single GF128 multiplication possibilities.

### 46.6.12 Galois Hash (GCM mode only)

**Name:** GHASH  
**Offset:** 0x6C + n\*0x04 [n=0..3]  
**Reset:** 0x00000000  
**Property:** PAC Write-Protection

Bit	31	30	29	28	27	26	25	24
	GHASH[31:24]							
Access	R/W	R/W	R/W	R/W	R/W	R/W	R/W	R/W
Reset	0	0	0	0	0	0	0	0
Bit	23	22	21	20	19	18	17	16
	GHASH[23:16]							
Access	R/W	R/W	R/W	R/W	R/W	R/W	R/W	R/W
Reset	0	0	0	0	0	0	0	0
Bit	15	14	13	12	11	10	9	8
	GHASH[15:8]							
Access	R/W	R/W	R/W	R/W	R/W	R/W	R/W	R/W
Reset	0	0	0	0	0	0	0	0
Bit	7	6	5	4	3	2	1	0
	GHASH[7:0]							
Access	R/W	R/W	R/W	R/W	R/W	R/W	R/W	R/W
Reset	0	0	0	0	0	0	0	0

#### Bits 31:0 – GHASH[31:0] Galois Hash Value

The four 32-bit Hash Word registers `GHASH` contain the `GHASH` value after GF128 multiplication in GCM mode. Writing a new key to `KEYWORD` registers causes `GHASH` to be initialized with zeroes. These registers can also be programmed.

### 46.6.13 Galois Hash x (GCM mode only)

**Name:** CIPLN  
**Offset:** 0x80  
**Reset:** 0x00000000  
**Property:** PAC Write-Protection

Bit	31	30	29	28	27	26	25	24
	CIPLN[31:24]							
Access	R/W	R/W	R/W	R/W	R/W	R/W	R/W	R/W
Reset	0	0	0	0	0	0	0	0
Bit	23	22	21	20	19	18	17	16
	CIPLN[23:16]							
Access	R/W	R/W	R/W	R/W	R/W	R/W	R/W	R/W
Reset	0	0	0	0	0	0	0	0
Bit	15	14	13	12	11	10	9	8
	CIPLN[15:8]							
Access	R/W	R/W	R/W	R/W	R/W	R/W	R/W	R/W
Reset	0	0	0	0	0	0	0	0
Bit	7	6	5	4	3	2	1	0
	CIPLN[7:0]							
Access	R/W	R/W	R/W	R/W	R/W	R/W	R/W	R/W
Reset	0	0	0	0	0	0	0	0

#### Bits 31:0 – CIPLN[31:0] Cipher Length

This register contains the length in bytes of the Cipher text that is to be processed. This is programmed by the user in GCM mode for Tag generation.

#### 46.6.14 Random Seed

**Name:** RANDSEED  
**Offset:** 0x84  
**Reset:** 0x00000000  
**Property:** PAC Write-Protection

Bit	31	30	29	28	27	26	25	24
	RANDSEED[31:24]							
Access	R/W	R/W	R/W	R/W	R/W	R/W	R/W	R/W
Reset	0	0	0	0	0	0	0	0
Bit	23	22	21	20	19	18	17	16
	RANDSEED[23:16]							
Access	R/W	R/W	R/W	R/W	R/W	R/W	R/W	R/W
Reset	0	0	0	0	0	0	0	0
Bit	15	14	13	12	11	10	9	8
	RANDSEED[15:8]							
Access	R/W	R/W	R/W	R/W	R/W	R/W	R/W	R/W
Reset	0	0	0	0	0	0	0	0
Bit	7	6	5	4	3	2	1	0
	RANDSEED[7:0]							
Access	R/W	R/W	R/W	R/W	R/W	R/W	R/W	R/W
Reset	0	0	0	0	0	0	0	0

#### Bits 31:0 – RANDSEED[31:0] Random Seed

A write to this register corresponds to loading a new seed into the Random number generator.

## 47. Public Key Cryptography Controller (PUKCC)

### 47.1 Overview

The Public Key Cryptography Controller (PUKCC) processes public key cryptography algorithm calculus in both GF(p) and GF(2n) fields.

The Public Key Cryptography Library (PUKCL) is stored in ROM inside the device. The library can be used in applications to access features of PUKCC, and includes the complete implementation of the following public key cryptography algorithms:

- RSA (Rivest-Shamir-Adleman public key cryptosystem), DSA (Digital Signature Algorithm):
  - Modular Exponentiation with CRT up to 7168 bits
  - Modular Exponentiation without CRT up to 5376 bits
  - Prime generation
  - Utilities: GCD/modular Inverse, Divide, Modular reduction, Multiply, ...
- Elliptic Curves:
  - ECDSA GF(p) up to 521 bits for common curves (up to 1120 bits for future use)
  - ECDSA GF(2n) up to 571 bits for common curves (up to 1440 bits for future use)
  - Choice of the curve parameters for compatibility with NIST Curves or other curves in Weierstrass equation
  - Point Multiply
  - Point Add/Doubling
  - Other high level elliptic curve algorithms (ECDH, ...) can be implemented by user using library functions
- Deterministic Random Number Generation (DRNG ANSI X9.31) for DSA

### 47.2 Features

The following are key features of the PUKCL module:

- PUKCL self-test, GCD, integral division, and so on.
- Modular reduction, modular exponentiation, probable prime generation, and modular exponentiation.
- Point addition and doubling on an elliptic curve in a prime field, ECDSA signature generation and verification on an elliptic curve over GF(p).
- Point addition and doubling on an elliptic curve in a prime field, ECDSA signature generation and verification on an elliptic curve over GF(2<sup>n</sup>).

### 47.3 Peripheral Dependencies

<b>Peripheral Name</b>	PUKCC - Public Key Cryptography Controller
<b>Base Address</b>	0x4200_3000 (Peripheral Bus C)
<b>MCLK APB Clock (1)</b>	CLK_PUKCC_AHB, Enabled, AHBMASK.PUKCC
<b>GCLK Peripheral Channel Index:Clock Name</b>	n/a
<b>PAC Peripheral Identifier (PAC.WRCTRL)</b>	76
<b>Note:</b>	
1. Clock Name, Default State, Mask Field.	

#### 47.3.1 Power Management

The PUKCC will continue to operate in any sleep mode, as long as its source clock is running.



### 47.3.2 Clocks

The bus clock (CLK\_PUKCC\_AHB) can be enabled and disabled by the [Main Clock Controller](#).

### 47.4 Functional Description

The PUKCL Library is supported in the Microchip MPLAB Harmony v3 Crypto Library: [github.com/  
Microchip-MPLAB-Harmony/crypto](https://github.com/Microchip-MPLAB-Harmony/crypto)

## 48. True Random Number Generator (TRNG)

### 48.1 Overview

The True Random Number Generator (TRNG) generates unpredictable random numbers that are not generated by an algorithm. It passes the American NIST Special Publication 800-22 and Diehard Random Tests Suites.

The TRNG may be used as an entropy source for seeding an NIST approved DRNG (Deterministic RNG) as required by FIPS PUB 140-2 and 140-3.

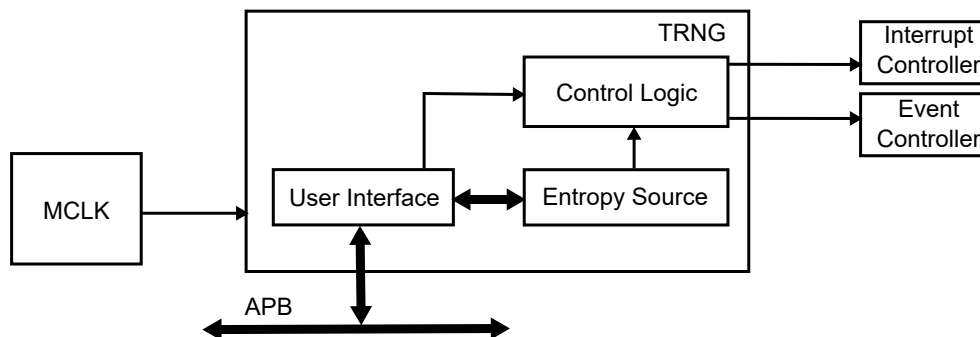
### 48.2 Features

The following are key features of the TRNG module:

- Passed NIST Special Publication 800-22 Tests Suite
- Passed Diehard Random Tests Suite
- May be used as Entropy Source for seeding an NIST approved DRNG (Deterministic RNG) as required by FIPS PUB 140-2 and 140-3
- Provides a 32-bit random number every 84 clock cycles

### 48.3 Block Diagram

Figure 48-1. TRNG Block Diagram.



### 48.4 Peripheral Dependencies

<b>Peripheral Name</b>	TRNG – True Random Number Generator
<b>Base Address</b>	0x4200_2800 (Peripheral Bus C)
<b>NVIC IRQ Index:Source</b>	131 : DATARDY
<b>MCLK APB Clock (1)</b>	CLK_TRNG_APB, Disabled, APBCMASK.TRNG
<b>GCLK Peripheral Channel Index:Clock Name</b>	n/a
<b>PAC Peripheral Identifier (PAC.WRCTRL)</b>	74
<b>EVSYS Users (EVSYS.USERm)</b>	n/a
<b>EVSYS Generators (EVSYS.CHANNELn)</b>	115 : TRNG Ready (TRNG_Ready)
<b>Note:</b>	
1.	Clock Name, Default State, Mask Field.

#### 48.4.1 Power Management

The functioning of TRNG depends on the sleep modes of the device.

The TRNG interrupts can be used to wake up the device from sleep modes. Events connected to the [event system](#) can trigger other operations in the system without exiting sleep modes.

#### 48.4.2 Clocks

The TRNG bus clock (CLK\_TRNG\_APB) can be enabled and disabled in the Main Clock module, and the default state of CLK\_TRNG\_APB can be found in [Peripheral Clock Masking](#).

#### 48.4.3 Debug Operation

When the CPU is halted in debug mode the TRNG continues normal operation. If the TRNG is configured in a way that requires it to be periodically serviced by the CPU through interrupts or similar, improper operation or data loss may result during debugging.

#### 48.4.4 Register Access Protection

All registers with write-access are optionally write-protected by the [Peripheral Access Controller \(PAC\)](#), except the following registers:

- Interrupt Flag Status and Clear (INTFLAG) register
- Output Data (DATA) register

Optional write protection by the [Peripheral Access Controller \(PAC\)](#) is denoted by the "PAC Write Protection" property in each individual register description.

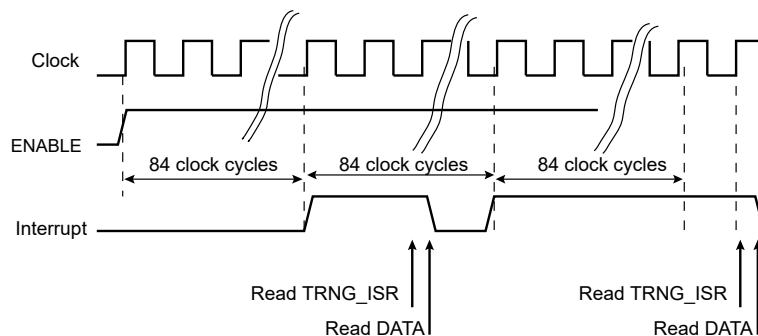
### 48.5 Functional Description

#### 48.5.1 Principle of Operation

When the TRNG is enabled, the peripheral starts providing new 32-bit random numbers every 84 CLK\_TRNG\_APB clock cycles.

The TRNG can be configured to generate an interrupt or event when a new random number is available.

**Figure 48-2.** TRNG Data Generation Sequence



#### 48.5.2 Basic Operation

##### 48.5.2.1 Initialization

To operate the TRNG, perform these actions:

- Configure the clock source for CLK\_TRNG\_APB in the Main Clock Controller (MCLK) and enable the clock by writing a '1' to the TRNG bit in the APB Mask register of the MCLK.
- Optional: Enable the output event by writing a '1' to the EVCTRL.DATARDYEO bit.
- Optional: Enable the TRNG to Run in Standby mode by writing a '1' to CTRLA.RUNSTDBY.

**Note:** A delay between TRNG Enable (CTRLA.ENABLE = 1) and the first random number read is required. For additional information, refer to the [55.39. TRNG Electrical Specifications](#).

The following register is enable-protected, meaning that it can only be written when the TRNG is disabled (CTRLA.ENABLE = 0): The Event Control (EVCTRL) register.

Enable-protection is denoted by the Enable-Protected property in the register description.

### 48.5.2.2 Enabling, Disabling and Resetting

The TRNG is enabled by writing '1' to the Enable bit in the Control A register (CTRLA.ENABLE).

The TRNG is disabled by writing a zero twice to CTRLA.ENABLE:

- CTRLA.ENABLE = 0;
- CTRLA.ENABLE = 0;

### 48.5.3 Interrupts

The TRNG has the following interrupt source:

- Data Ready (DATARDY): Indicates that a new random number is available in the DATA register and ready to be read.

This interrupt is a synchronous wake-up source. See [Sleep Mode Controller](#) for details.

The interrupt source has an interrupt flag associated with it. The interrupt flag in the Interrupt Flag Status and Clear register (INTFLAG.DATARDY) is set to '1' when the interrupt condition occurs. The interrupt can be enabled by writing a '1' to the corresponding bit in the Interrupt Enable Set register (INTENSET.DATARDY), and disabled by writing a '1' to the corresponding bit in the Interrupt Enable Clear (INTENCLR) register.

An interrupt request is generated when the interrupt flag is set and the corresponding interrupt is enabled. The interrupt request remains active until the interrupt flag is cleared, or the interrupt is disabled. See [48.6.5. INTFLAG](#) for details on how to clear interrupt flags.

Note that interrupts must be globally enabled for interrupt requests to be generated.

### 48.5.4 Events

The TRNG can generate the following output event:

- Data Ready (DATARDY): Generated when a new random number is available in the DATA register.

Writing '1' to the Data Ready Event Output bit in the Event Control Register (EVCTRL.DATARDYEO) enables the DTARDY event. Writing a '0' to this bit disables the corresponding output event. Refer to [EVSYS – Event System](#) for details on configuring the Event System.

### 48.5.5 Sleep Mode Operation

The Run in Standby bit in Control A register (CTRLA.RUNSTDBY) controls the behavior of the TRNG during standby sleep mode:

When this bit is '0', the TRNG is disabled during sleep, but maintains its current configuration.

When this bit is '1', the TRNG continues to operate during sleep and any enabled TRNG interrupt source can wake up the CPU.

## 48.6 Register Summary

Offset	Name	Bit Pos.	7	6	5	4	3	2	1	0
0x00	CTRLA	7:0		RUNSTDBY					ENABLE	
0x01	Reserved									
...										
0x03										
0x04	EVCTRL	7:0								DATARDYEO
0x05	Reserved									
...										
0x07										
0x08	INTENCLR	7:0								DATARDY
0x09	INTENSET	7:0								DATARDY
0x0A	INTFLAG	7:0								DATARDY
0x0B	Reserved									
...										
0x1F										
0x20	DATA	7:0	DATA[7:0]							
		15:8	DATA[15:8]							
		23:16	DATA[23:16]							
		31:24	DATA[31:24]							

### 48.6.1 Control A

**Name:** CTRLA  
**Offset:** 0x00  
**Reset:** 0x00  
**Property:** PAC Write-Protection

Bit	7	6	5	4	3	2	1	0
		RUNSTDBY					ENABLE	
Access		R/W					R/W	
Reset		0					0	

#### Bit 6 – RUNSTDBY Run in Standby

This bit controls how the TRNG behaves during standby sleep mode:

Value	Description
0	The TRNG is halted during standby sleep mode.
1	The TRNG is not stopped in standby sleep mode.

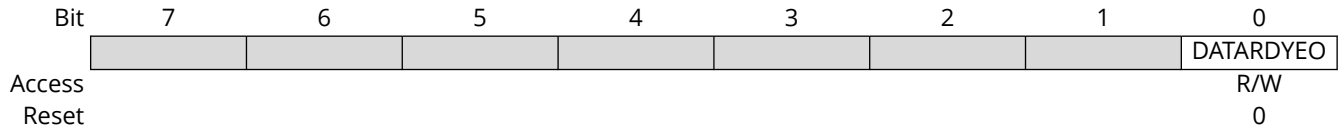
#### Bit 1 – ENABLE Enable

**Note:** A delay between TRNG Enable (CTRLA.ENABLE=1) and the first random number read is required. Refer to the [TRNG Electrical Specifications](#).

Value	Description
0	The TRNG is disabled.
1	The TRNG is enabled.

## 48.6.2 Event Control

**Name:** EVCTRL  
**Offset:** 0x04  
**Reset:** 0x00  
**Property:** PAC Write-Protection, Enable-Protected



### Bit 0 – DATARDYEO Data Ready Event Output

This bit indicates whether the Data Ready event output is enabled and whether an output event will be generated when a new random value is ready.

Value	Description
0	Data Ready event output is disabled and an event will not be generated.
1	Data Ready event output is enabled and an event will be generated.

### 48.6.3 Interrupt Enable Clear

**Name:** INTENCLR  
**Offset:** 0x08  
**Reset:** 0x00  
**Property:** PAC Write-Protection

This register allows the user to disable an interrupt without doing a read-modify-write operation. Changes in this register will also be reflected in the Interrupt Enable Set (INTENSET) register.

Bit	7	6	5	4	3	2	1	0
								DATARDY
Access								R/W
Reset								0

#### Bit 0 – DATARDY Data Ready Interrupt Enable

Writing a '1' to this bit will clear the Data Ready Interrupt Enable bit, which disables the corresponding interrupt request.

Value	Description
0	The DATARDY interrupt is disabled.
1	The DATARDY interrupt is enabled.



#### 48.6.4 Interrupt Enable Set

**Name:** INTENSET  
**Offset:** 0x09  
**Reset:** 0x00  
**Property:** PAC Write-Protection

This register allows the user to enable an interrupt without doing a read-modify-write operation. Changes in this register will also be reflected in the Interrupt Enable Clear (INTENCLR) register.

Bit	7	6	5	4	3	2	1	0
								DATARDY
Access								R/W
Reset								0

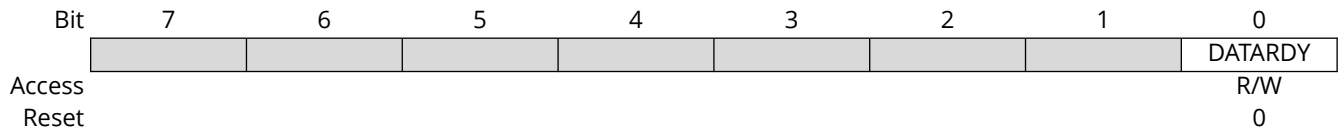
##### Bit 0 – DATARDY Data Ready Interrupt Enable

Writing a '1' to this bit will set the Data Ready Interrupt Enable bit, which enables the corresponding interrupt request.

Value	Description
0	The DATARDY interrupt is disabled.
1	The DATARDY interrupt is enabled.

### 48.6.5 Interrupt Flag Status and Clear

**Name:** INTFLAG  
**Offset:** 0x0A  
**Reset:** 0x00  
**Property:** -



**Bit 0 – DATARDY** Data Ready

This flag is set when a new random value is generated, and an interrupt will be generated if INTENCLR/SET.DATARDY=1.

This flag is cleared by writing a '1' to the flag or by reading the DATA register.

Writing a '0' to this bit has no effect.

## 48.6.6 Output Data

**Name:** DATA  
**Offset:** 0x20  
**Reset:** 0xFFFFFFFF  
**Property:** -

Bit	31	30	29	28	27	26	25	24
	DATA[31:24]							
Access	R	R	R	R	R	R	R	R
Reset	x	x	x	x	x	x	x	x
Bit	23	22	21	20	19	18	17	16
	DATA[23:16]							
Access	R	R	R	R	R	R	R	R
Reset	x	x	x	x	x	x	x	x
Bit	15	14	13	12	11	10	9	8
	DATA[15:8]							
Access	R	R	R	R	R	R	R	R
Reset	x	x	x	x	x	x	x	x
Bit	7	6	5	4	3	2	1	0
	DATA[7:0]							
Access	R	R	R	R	R	R	R	R
Reset	x	x	x	x	x	x	x	x

### Bits 31:0 – DATA[31:0] Output Data

These bits hold the 32-bit randomly generated output data.

## 49. Integrity Check Monitor (ICM)

### 49.1 Overview

The Integrity Check Monitor (ICM) is a DMA controller that performs hash calculation over multiple memory regions using of transfer descriptors located in memory (ICM Descriptor Area). The Hash function is based on the Secure Hash Algorithm (SHA). The ICM controller integrates two modes of operation. The first mode is used to hash a list of memory regions and save the digests to memory (ICM Hash Area). The second mode is an active monitoring of the memory. In this mode, the hash function is evaluated and compared to the digest located at a predefined memory address (ICM Hash Area). If a mismatch occurs, an interrupt is raised.

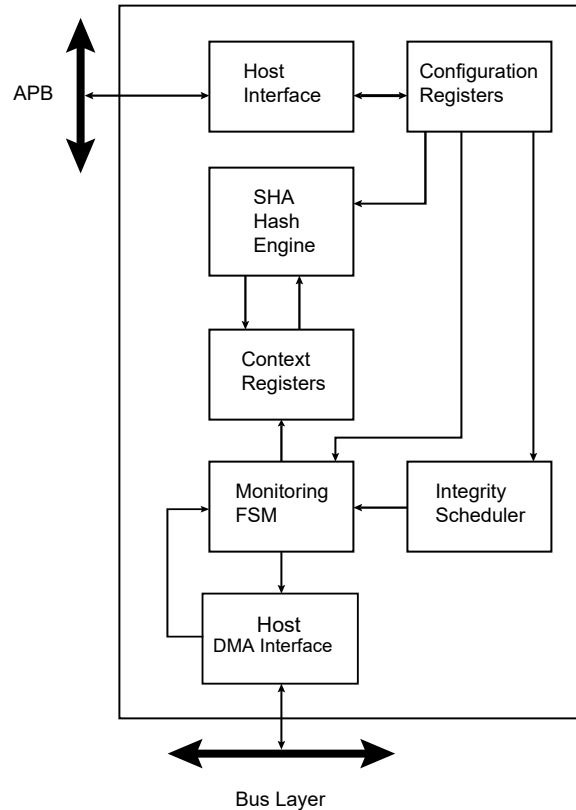
### 49.2 Features

The following are key features of the ICM:

- DMA AHB Host interface
- Supports monitoring of up to four non-contiguous memory regions
- Supports block gathering using a linked list
- Supports Secure Hash Algorithm (SHA1, SHA224, SHA256)
- Compliant with FIPS Publication 180-2
- Configurable processing period:
  - When SHA1 algorithm is processed, the run-time period is either 85 or 209 clock cycles
  - When SHA256 or SHA224 algorithm is processed, the run-time period is either 72 or 194 clock cycles
- Programmable bus burden

## 49.3 Block Diagram

Figure 49-1. Integrity Check Monitor Block Diagram



## 49.4 Peripheral Dependencies

<b>Peripheral Name</b>	ICM - Integrity Check Monitor
<b>Base Address</b>	0x4200_2C00 (Peripheral Bus C)
<b>NVIC IRQ Index:Source</b>	132 : All Interrupts
<b>MCLK APB Clock (1)</b>	CLK_ICM_AHB, Enabled, AHBMASK.ICM CLK_ICM_APB, Disabled, APBCMASK.ICM
<b>GCLK Peripheral Channel Index:Clock Name</b>	n/a
<b>PAC Peripheral Identifier (PAC.WRCTRL)</b>	Not supported by PAC
<b>Note:</b>	
	1. Clock Name, Default State, Mask Field.

### 49.4.1 Power Management

The ICM will run only when the source clocks are running, that is, when the CPU is in Active mode.

### 49.4.2 Clocks

The ICM bus clocks (CLK\_ICM\_AHB and CLK\_ICM\_APB) can be enabled and disabled in the [Main Clock module \(MCLK\)](#) by writing the respective bit in the mask registers (MCLK.AHBMASK.ICM and MCLK.APBCMASK.ICM).

The default states of CLK\_ICM\_AHB and CLK\_ICM\_APB are given by the reset values of the respective mask registers.

## 49.5 Functional Description

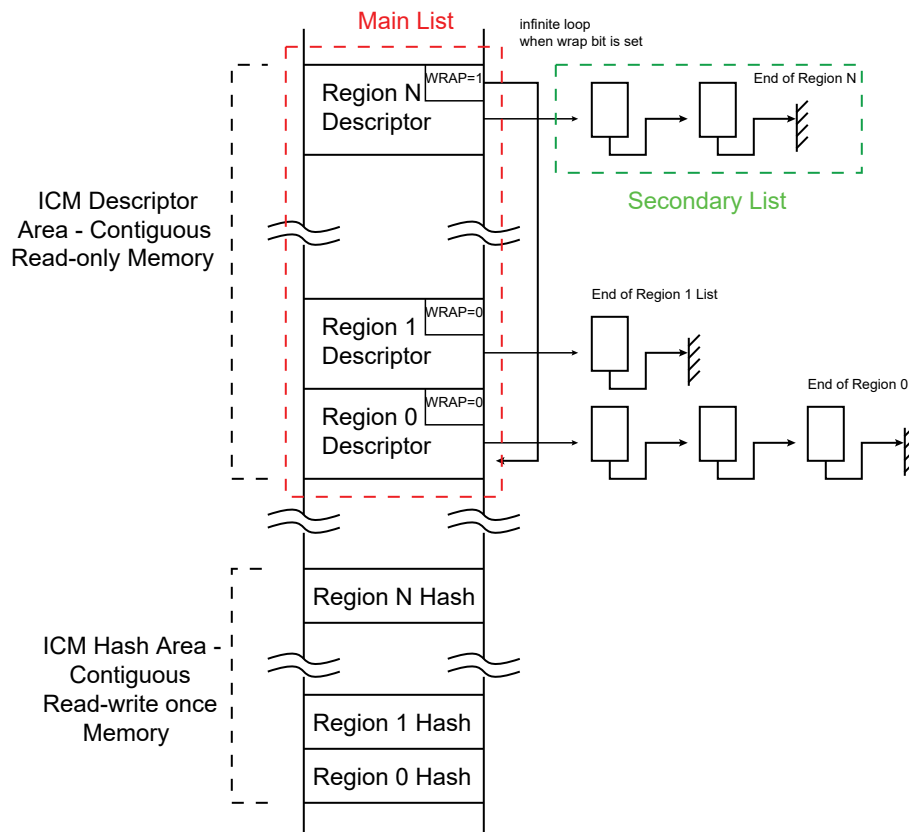
### 49.5.1 Overview

The Integrity Check Monitor (ICM) is a DMA controller that performs SHA-based memory hashing over memory regions. As shown in [the Block Diagram](#), it integrates a DMA interface, a Monitoring Finite State Machine (FSM), an integrity scheduler, a set of context registers, a SHA engine, an interface for configuration and status registers.

The SHA engine requires a message padded according to FIPS180-4 specification when used as a SHA calculation unit only. Otherwise, if the ICM is used as an integrated check for memory content, the padding is not mandatory. The SHA module produces an N-bit message digest each time a block is read and a processing period ends. "N" is 160 for SHA1, 224 for SHA224, 256 for SHA256.

When the ICM module is enabled, it sequentially retrieves a circular list of region descriptors from the memory. The Main List is described in the following figure. Up to four regions may be monitored. Each region descriptor is composed of four words indicating the layout of the memory region (refer to the example given in [49.5.3. Region Descriptor Structure](#)). It also contains the hashing engine configuration on a per region basis. As soon as the descriptor is loaded from the memory and context registers are updated with the data structure, the hashing operation starts. A programmable number of blocks (see TRSIZE field of the RCTRL structure member) is transferred from the memory to the SHA engine. When the desired number of blocks have been transferred, the digest is either moved to memory (Write Back function) or compared with a digest reference located in the system memory (Compare function). If a digest mismatch occurs, an interrupt is triggered if enabled. The ICM module passes through the region descriptor list until the end of the list marked by an end of list marker (WRAP or EOM bit in ICM\_RCFG structure member set to one). To continuously monitor the list of regions, the WRAP bit must be set to one in the last data structure and EOM must be cleared.

**Figure 49-2.** ICM Region Descriptor and Hash Areas









than one region is to be moderated), the fetch address is  $DSCR + RID \ll 4$  where RID is the region identifier.

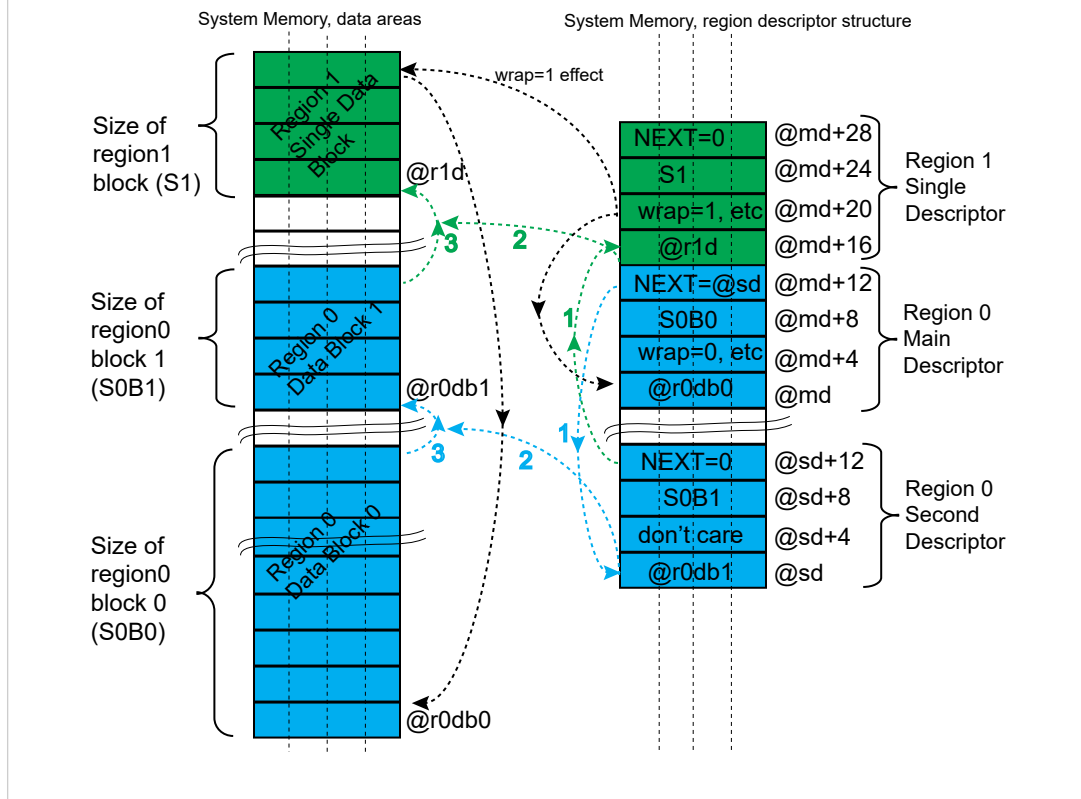
**Table 49-1.** Region Descriptor Structure (Main List)

Offset	Structure Member	Name
DSCR+0x00+RID*(0x10)	ICM Region Start Address	RADDR
DSCR+0x04+RID*(0x10)	ICM Region Configuration	RCFG
DSCR+0x08+RID*(0x10)	ICM Region Control	RCTRL
DSCR+0x0C+RID*(0x10)	ICM Region Next Address	RNEXT

**Example 49-1.** ICM Monitoring of 3 Memory Data Blocks (Defined as 2 Regions)

The following figure shows the mandatory ICM settings to monitor three memory data blocks of the system memory (defined as two regions) with one region being not contiguous (two separate areas) and one contiguous memory area. For each said region, the SHA algorithm may be independently selected (different for each region). The wrap allows continuous monitoring.

**Figure 49-4.** Example - Monitoring of 3 Memory Data Blocks (Defined as 2 Regions)



### 49.5.3.1 Region Descriptor Structure Overview

Offset	Name	Bit Pos.	7	6	5	4	3	2	1	0
0x00	RADDR0	7:0	RADDR[7:0]							
		15:8	RADDR[15:8]							
		23:16	RADDR[23:16]							
		31:24	RADDR[31:24]							
0x04	RCFG0	7:0	WCIEEN	BEIEEN	DMIEEN	RHIEEN		EOM	WRAP	CDWBN
		15:8	ALGO[2:0]					PROCDLY	SUIEEN	ECIEEN
		23:16								
		31:24								
0x08	RCTRL0	7:0	TRSIZE[7:0]							
		15:8	TRSIZE[15:8]							
		23:16								
		31:24								
0x0C	RADDR1	7:0	RADDR[7:0]							
		15:8	RADDR[15:8]							
		23:16	RADDR[23:16]							
		31:24	RADDR[31:24]							
0x0C	RNEXT0	7:0	RNEXT[7:0]							
		15:8	RNEXT[15:8]							
		23:16	RNEXT[23:16]							
		31:24	RNEXT[31:24]							
0x10	RCFG1	7:0	WCIEEN	BEIEEN	DMIEEN	RHIEEN		EOM	WRAP	CDWBN
		15:8	ALGO[2:0]					PROCDLY	SUIEEN	ECIEEN
		23:16								
		31:24								
0x14	RCTRL1	7:0	TRSIZE[7:0]							
		15:8	TRSIZE[15:8]							
		23:16								
		31:24								
0x18	RADDR2	7:0	RADDR[7:0]							
		15:8	RADDR[15:8]							
		23:16	RADDR[23:16]							
		31:24	RADDR[31:24]							
0x18	RNEXT1	7:0	RNEXT[7:0]							
		15:8	RNEXT[15:8]							
		23:16	RNEXT[23:16]							
		31:24	RNEXT[31:24]							
0x1C	RCFG2	7:0	WCIEEN	BEIEEN	DMIEEN	RHIEEN		EOM	WRAP	CDWBN
		15:8	ALGO[2:0]					PROCDLY	SUIEEN	ECIEEN
		23:16								
		31:24								
0x20	RCTRL2	7:0	TRSIZE[7:0]							
		15:8	TRSIZE[15:8]							
		23:16								
		31:24								
0x24	RADDR3	7:0	RADDR[7:0]							
		15:8	RADDR[15:8]							
		23:16	RADDR[23:16]							
		31:24	RADDR[31:24]							
0x24	RNEXT2	7:0	RNEXT[7:0]							
		15:8	RNEXT[15:8]							
		23:16	RNEXT[23:16]							
		31:24	RNEXT[31:24]							
0x28	RCFG3	7:0	WCIEEN	BEIEEN	DMIEEN	RHIEEN		EOM	WRAP	CDWBN
		15:8	ALGO[2:0]					PROCDLY	SUIEEN	ECIEEN
		23:16								
		31:24								

.....continued

Offset	Name	Bit Pos.	7	6	5	4	3	2	1	0	
0x2C	RCTRL3	7:0	TRSIZE[7:0]								
		15:8	TRSIZE[15:8]								
		23:16									
		31:24									
0x30	RNEXT3	7:0	RNEXT[7:0]								
		15:8	RNEXT[15:8]								
		23:16	RNEXT[23:16]								
		31:24	RNEXT[31:24]								

### 49.5.3.1.1 Region Start Address Structure Member

**Name:** RADDR  
**Offset:** 0x00 + n\*0x0C [n=0..3]  
**Reset:** 0x00000000  
**Property:** Read/Write

Bit	31	30	29	28	27	26	25	24
	RADDR[31:24]							
Access	R/W	R/W	R/W	R/W	R/W	R/W	R/W	R/W
Reset	0	0	0	0	0	0	0	0
Bit	23	22	21	20	19	18	17	16
	RADDR[23:16]							
Access	R/W	R/W	R/W	R/W	R/W	R/W	R/W	R/W
Reset	0	0	0	0	0	0	0	0
Bit	15	14	13	12	11	10	9	8
	RADDR[15:8]							
Access	R/W	R/W	R/W	R/W	R/W	R/W	R/W	R/W
Reset	0	0	0	0	0	0	0	0
Bit	7	6	5	4	3	2	1	0
	RADDR[7:0]							
Access	R/W	R/W	R/W	R/W	R/W	R/W	R/W	R/W
Reset	0	0	0	0	0	0	0	0

**Bits 31:0 – RADDR[31:0]** Region Start Address  
This field indicates the first byte address of the region

### 49.5.3.1.2 Region Configuration Structure Member

**Name:** RCFG  
**Offset:** 0x04 + n\*0x0C [n=0..3]  
**Reset:** 0x00000000  
**Property:** Read/Write

Bit	31	30	29	28	27	26	25	24
Access								
Reset								
Bit	23	22	21	20	19	18	17	16
Access								
Reset								
Bit	15	14	13	12	11	10	9	8
Access		ALGO[2:0]				PROCDLY	SUIEN	ECIEN
Reset		R/W	R/W	R/W		R/W	R/W	R/W
Reset		0	0	0		0	1	1
Bit	7	6	5	4	3	2	1	0
Access	WCIEEN	BEIEN	DMIEN	RHIEN		EOM	WRAP	CDWBN
Reset	R/W	R/W	R/W	R/W		R/W	R/W	R/W
Reset	1	1	1	1		0	0	0

#### Bits 14:12 – ALGO[2:0] User SHA Algorithm

Value	Name	Description
0	SHA1	SHA1 algorithm processed
1	SHA256	SHA256 algorithm processed
4	SHA224	SHA224 algorithm processed
Other	-	Reserved

#### Bit 10 – PROCDLY Processing Delay

For a given SHA algorithm, the runtime period has two possible lengths:

**Table 49-2.** SHA Processing Runtime Periods

Algorithm	SHORTEST [number of cycles]	LONGEST [number of cycles]
SHA1	85	209
SHA224	72	194
SHA256	72	194

Value	Name	Description
0	SHORTEST	SHA processing runtime is the shortest one
1	LONGEST	SHA processing runtime is the longest one

#### Bit 9 – SUIEN Monitoring Status Updated Condition Interrupt Enable

0: The RSU flag is set when the corresponding descriptor is loaded from memory to ICM.  
 1: The RSU flag remains cleared even if the condition is met.

#### Bit 8 – ECIEN End Bit Condition Interrupt Enable

0: The REC flag is set when the descriptor having the EOM bit set is processed.  
 1: The REC flag remains cleared even if the setting condition is met.

**Bit 7 - WCIEN** Wrap Condition Interrupt Disable

0: The RWC flag is set when the WRAP

1: The RWC flag remains cleared even if the setting condition is met.

**Bit 6 - BEIEN** Bus Error Interrupt Disable

0: The flag is set when an error is reported on the system bus by the bus MATRIX.

1: The flag remains cleared even if the setting condition is met.

**Bit 5 - DMIEN** Digest Mismatch Interrupt Disable

0: The RBE flag is set when the hash value just calculated from the processed region differs from expected hash value.

1: The RBE flag remains cleared even if the setting condition is met.

**Bit 4 - RHIEN** Region Hash Completed Interrupt Disable

0: The RHC flag is set when the field NEXT = 0 in a descriptor of the main or second list.

1: The RHC flag remains cleared even if the setting condition is met.

**Bit 2 - EOM** End of Monitoring

0: The current descriptor does not terminate the monitoring.

1: The current descriptor terminates the Main List. WRAP bit value has no effect.

**Bit 1 - WRAP** Wrap Command

0: The next region descriptor address loaded is the current region identifier descriptor address incremented by 0x10.

1: The next region descriptor address loaded is DSCR.

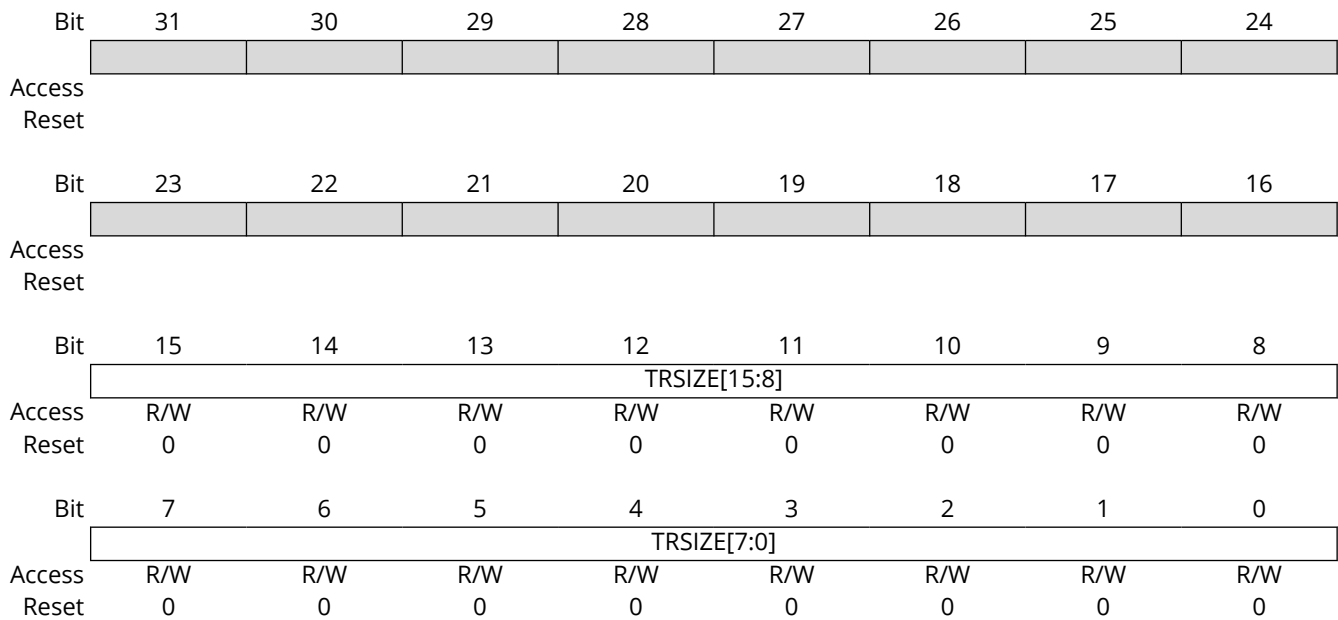
**Bit 0 - CDWBN** Compare Digest or Write Back Digest

0: The digest is written to the Hash area.

1: The digest value is compared to the digest stored in the Hash area.

### 49.5.3.1.3 Region Control Structure Member

**Name:** RCTRL  
**Offset:** 0x08 + n\*0x0C [n=0..3]  
**Reset:** 0x00000000  
**Property:** R/W



**Bits 15:0 – TRSIZE[15:0]** Transfer Size for the Current Chunk of Data

#### 49.5.3.1.4 Region Next Address Structure Member

**Name:** RNEXT  
**Offset:** 0x0C + n\*0x0C [n=0..3]  
**Reset:** 0x00000000  
**Property:** Read/Write

Bit	31	30	29	28	27	26	25	24
	RNEXT[31:24]							
Access	R/W	R/W	R/W	R/W	R/W	R/W	R/W	R/W
Reset	0	0	0	0	0	0	0	0
Bit	23	22	21	20	19	18	17	16
	RNEXT[23:16]							
Access	R/W	R/W	R/W	R/W	R/W	R/W	R/W	R/W
Reset	0	0	0	0	0	0	0	0
Bit	15	14	13	12	11	10	9	8
	RNEXT[15:8]							
Access	R/W	R/W	R/W	R/W	R/W	R/W	R/W	R/W
Reset	0	0	0	0	0	0	0	0
Bit	7	6	5	4	3	2	1	0
	RNEXT[7:0]							
Access	R/W	R/W	R/W	R/W	R/W	R/W	R/W	R/W
Reset	0	0	0	0	0	0	0	0

#### Bits 31:0 – RNEXT[31:0] Region Next Start Address

This field indicates the first byte address of the next part of the region.

#### 49.5.4 Using ICM as an SHA Engine

The ICM can be configured to only calculate a SHA1, SHA224, SHA256 digest value.

##### 49.5.4.1 Settings for Simple SHA Calculation

The start address of the system memory containing the data to hash must be configured in the transfer descriptor of the DMA embedded in the ICM.

The transfer descriptor is a system memory area integer multiple of 4 x 32-bit word and the start address of the descriptor must be configured in [DSCR](#) (the start address must be aligned on 64-bytes; six LSB must be cleared). If the data to hash is already padded according to SHA standards, only a single descriptor is required, and the EOM bit of the region configuration register ([RCFGn](#)) must be written to 1. If the data to hash does not contain a padding area, it is possible to define the padding area in another system memory location, the ICM can be configured to automatically jump from a memory area to another one by writing the region descriptor register [RNEXT](#) with a value that differs from 0. Writing the [RNEXT](#) register with the start address of the padding area forces the ICM to concatenate both areas, thus providing the SHA result from the start address of the hash area configured in [HASH](#).

Whether the system memory is configured as a single or multiple data block area, the bits [CDWBN](#) and [WRAP](#) must be cleared in the region descriptor structure member [RCFGn](#). The bits [WBDIS](#), [EOMDIS](#), [SLBDIS](#) must be cleared in [CFG](#) to prevent disabling the Write Back, End of Monitoring, and Secondary List capabilities, respectfully.

Write the bits RHIEEN and ECIEN in the Region Configuration Structure Member (RCFGn) to '0':



- The flag RHC[i], i being the region index, is set (if RHIEN is '0') when the hash result is available at address defined in [HASH](#).
- The flag REC[i], i being the region index, is set (if ECIEN is '0') when the hash result is available at the address defined in [HASH](#).

An interrupt is generated if the bit [RHC\[i\]](#) is written to '1' in the [IER](#) (if [RHC\[i\]](#) is set in [RCTRL](#) of region i) or if the bit [REC\[i\]](#) is written to 1 in the [IER](#) (if [REC\[i\]](#) is set in [RCTRL](#) of region i).

#### 49.5.4.2 Processing Period

The SHA engine processing period can be configured by writing to the Region Configuration Structure Member register (RCFGn).

The short processing period allows to allocate bandwidth to the SHA module whereas the long processing period allocates more bandwidth on the system bus to other applications.

In SHA mode, the shortest processing period is 85 clock cycles + 2 clock cycles for start command synchronization. The longest period is 209 clock cycles + 2 clock cycles.

In SHA256 and SHA224 modes, the shortest processing period is 72 clock cycles + 2 clock cycles for start command synchronization. The longest period is 194 clock cycles + 2 clock cycles.

#### 49.5.5 ICM Automatic Monitoring Mode

The [ASCD](#) bit of the [CFG](#) register is used to activate the ICM Automatic Mode. When [CFG.ASCD](#) is set, the ICM performs the following actions:

- The ICM controller passes through the Main List once with [CDWBN](#) bit in [RCFGn](#) at 0 (i.e., Write Back activated) and [EOM](#) bit in the [RCFGn](#) context register at 0.
- When [RCFGn.WRAP](#)=1, the ICM controller enters active monitoring, with [CDWBN](#) bit in context register now set, and [EOM](#) bit in context register cleared. Writing to the [CDWBN](#) and [EOM](#) bits in [RCFGn](#) has no effect.

#### 49.5.6 ICM Configuration Parameters

Transfer Type		Main List	RCFG			RNEXT	Comments
			CDWBN	WRAP	EOM	NEXT	
Single Region	Contiguous list of blocks	1 item	0	0	1	0	The Main List contains only one descriptor. The Secondary List is empty for that descriptor. The digest is computed and saved to memory.
	Digest written to memory						
	Monitoring disabled						
Non-contiguous list of blocks	Non-contiguous list of blocks	1 item	0	0	1	Secondary List address of the current region identifier	The Main List contains only one descriptor. The Secondary List describes the layout of the non-contiguous region.
	Digest written to memory						
	Monitoring disabled						
Contiguous list of blocks	Contiguous list of blocks	1 item	1	1	0	0	When the hash computation is terminated, the digest is compared with the one saved in memory.
	Digest comparison enabled						
	Monitoring enabled						

.....continued

Transfer Type		Main List	RCFG			RNEXT	Comments
			CDWBN	WRAP	EOM	NEXT	
Multiple Regions	Contiguous list of blocks Digest written to memory Monitoring disabled	More than one item	0	0	1 for the last, 0 otherwise	0	ICM passes through the list once.
	Contiguous list of blocks  Digest comparison is enabled  Monitoring is enabled	More than one item	1	1 for the last, 0 otherwise	0	0	ICM performs active monitoring of the regions. If a mismatch occurs, an interrupt is raised.
	Non-contiguous list of blocks Digest is written to memory Monitoring is disabled	More than one item	0	0	1	Secondary List address	ICM performs hashing and saves digests to the Hash area.
	Non-contiguous list of blocks Digest comparison is enabled  Monitoring is enabled	More than one item	1	1	0	Secondary List address	ICM performs data gathering on a per region basis.

#### 49.5.7 Security Features

When an undefined register access occurs, the URAD bit in the Interrupt Status Register (**ISR**) is set if unmasked. Its source is then reported in the Undefined Access Status Register (**UASR**). Only the first undefined register access is available through the **UASR.URAT** field.

Several kinds of unspecified register accesses can occur:

- Unspecified structure member set to one detected when the descriptor is loaded
- Configuration register (**CFG**) modified during active monitoring
- Descriptor register (**DSCR**) modified during active monitoring
- Hash register (**HASH**) modified during active monitoring
- Write-only register read access

The URAD bit and the URAT field can only be reset by writing a 1 to the **CTRL.SWRST** bit.

## 49.6 Register Summary - ICM

Offset	Name	Bit Pos.	7	6	5	4	3	2	1	0
0x00	CFG	7:0	BBC[3:0]					SLBDIS	EOMDIS	WBDIS
		15:8	UALGO[2:0]		UIHASH			DUALBUFF	ASCD	
		23:16								
		31:24								
0x04	CTRL	7:0	REHASH[3:0]					SWRST	DISABLE	ENABLE
		15:8	RMEN[3:0]				RMDIS[3:0]			
		23:16								
		31:24								
0x08	SR	7:0								ENABLE
		15:8	RMDIS[3:0]				RAWRMDIS[3:0]			
		23:16								
		31:24								
0x0C ... 0x0F	Reserved									
0x10	IER	7:0	RDM[3:0]					RHC[3:0]		
		15:8	RWC[3:0]				RBE[3:0]			
		23:16	RSU[3:0]				REC[3:0]			
		31:24								URAD
0x14	IDR	7:0	RDM[3:0]					RHC[3:0]		
		15:8	RWC[3:0]				RBE[3:0]			
		23:16	RSU[3:0]				REC[3:0]			
		31:24								URAD
0x18	IMR	7:0	RDM[3:0]					RHC[3:0]		
		15:8	RWC[3:0]				RBE[3:0]			
		23:16	RSU[3:0]				REC[3:0]			
		31:24								URAD
0x1C	ISR	7:0	RDM[3:0]					RHC[3:0]		
		15:8	RWC[3:0]				RBE[3:0]			
		23:16	RSU[3:0]				REC[3:0]			
		31:24								URAD
0x20	UASR	7:0						URAT[2:0]		
		15:8								
		23:16								
		31:24								
0x24 ... 0x2F	Reserved									
0x30	DSCR	7:0	DASA[1:0]							
		15:8			DASA[9:2]					
		23:16			DASA[17:10]					
		31:24			DASA[25:18]					
0x34	HASH	7:0	HASA[0]							
		15:8			HASA[8:1]					
		23:16			HASA[16:9]					
		31:24			HASA[24:17]					
0x38	UIHVAL0	7:0			VAL[7:0]					
		15:8			VAL[15:8]					
		23:16			VAL[23:16]					
		31:24			VAL[31:24]					
0x3C	UIHVAL1	7:0			VAL[7:0]					
		15:8			VAL[15:8]					
		23:16			VAL[23:16]					
		31:24			VAL[31:24]					
0x40	UIHVAL2	7:0			VAL[7:0]					
		15:8			VAL[15:8]					
		23:16			VAL[23:16]					
		31:24			VAL[31:24]					

.....continued

Offset	Name	Bit Pos.	7	6	5	4	3	2	1	0
0x44	UIHVAL3	7:0								VAL[7:0]
		15:8								VAL[15:8]
		23:16								VAL[23:16]
		31:24								VAL[31:24]
0x48	UIHVAL4	7:0								VAL[7:0]
		15:8								VAL[15:8]
		23:16								VAL[23:16]
		31:24								VAL[31:24]
0x4C	UIHVAL5	7:0								VAL[7:0]
		15:8								VAL[15:8]
		23:16								VAL[23:16]
		31:24								VAL[31:24]
0x50	UIHVAL6	7:0								VAL[7:0]
		15:8								VAL[15:8]
		23:16								VAL[23:16]
		31:24								VAL[31:24]
0x54	UIHVAL7	7:0								VAL[7:0]
		15:8								VAL[15:8]
		23:16								VAL[23:16]
		31:24								VAL[31:24]

## 49.6.1 Configuration Register

**Name:** CFG  
**Offset:** 0x00  
**Reset:** 0x0  
**Property:** -

Bit	31	30	29	28	27	26	25	24
Access								
Reset								
Bit	23	22	21	20	19	18	17	16
Access								
Reset								
Bit	15	14	13	12	11	10	9	8
Access	UALGO[2:0]			UIHASH			DUALBUFF	ASCD
Reset	-	-	-	-			-	R/W
Reset	0	0	0	0			0	0
Bit	7	6	5	4	3	2	1	0
Access	BBC[3:0]					SLBDIS	EOMDIS	WBDIS
Reset	R/W	R/W	R/W	R/W		R/W	R/W	R/W
Reset	0	0	0	0		0	0	0

### Bits 15:13 – UALGO[2:0] User SHA Algorithm

Value	Name	Description
0	SHA1	SHA1 algorithm processed
1	SHA256	SHA256 algorithm processed
4	SHA224	SHA224 algorithm processed
Other	-	Reserved

### Bit 12 – UIHASH User Initial Hash Value

Value	Description
0	The secure hash standard provides the initial hash value.
1	The initial hash value is programmable. Field UALGO provides the SHA algorithm. The ALGO field of the RCFGn structure member has no effect.

### Bit 9 – DUALBUFF Dual Input Buffer

Value	Description
0	Dual Input buffer mode is disabled.
1	Dual Input buffer mode is enabled (Better performances, higher bandwidth required on system bus).

### Bit 8 – ASCD Automatic Switch To Compare Digest

Value	Description
0	Automatic mode is disabled.
1	When this mode is enabled, the ICM controller automatically switches to active monitoring after the first Main List pass. Both CDWBN and WBDIS bits have no effect. A '1' must be written to the End of Monitoring bit in the Region Configuration register (RCFG.EOM) to terminate the monitoring.

**Bits 7:4 – BBC[3:0]** Bus Burden Control

This field is used to control the burden of the ICM system bus. The number of system clock cycles between the end of the current processing and the next block transfer is set to  $2^{\text{BBC}}$ . Up to 32768 cycles can be inserted.

**Bit 2 – SLBDIS** Secondary List Branching Disable

Value	Description
0	Branching to the Secondary List is permitted.
1	Branching to the Secondary List is forbidden. The NEXT field of the RNEXT structure member has no effect and is always considered as zero.

**Bit 1 – EOMDIS** End of Monitoring Disable

Value	Description
0	End of Monitoring is permitted.
1	End of Monitoring is forbidden. The EOM bit of the RCFG structure member has no effect.

**Bit 0 – WBDIS** Write Back Disable

1:

When the Automatic Switch to Compare Digest bit of this register (CFG.ASCD) is written to '1', this bit value has no effect.

Value	Description
0	Write Back Operations are permitted.
1	Write Back Operations are forbidden: Context register CDWBN bit is internally set to '1' and cannot be modified by a linked list element. The CDWBN bit of the RCFG structure member has no effect.

## 49.6.2 Control Register

**Name:** CTRL  
**Offset:** 0x04  
**Property:** -

Bit	31	30	29	28	27	26	25	24
Access								
Reset								
Bit	23	22	21	20	19	18	17	16
Access								
Reset								
Bit	15	14	13	12	11	10	9	8
Access	RMEN[3:0]				RMDIS[3:0]			
Reset	W	W	W	W	W	W	W	W
Bit	7	6	5	4	3	2	1	0
Access	REHASH[3:0]					SWRST	DISABLE	ENABLE
Reset	W	W	W	W		W	W	W
							0	0

### Bits 15:12 – RMEN[3:0] Region Monitoring Enable

Value	Description
0	No effect.
1	When bit RMEN[i] is written to '1', the monitoring of region with identifier i is activated.

### Bits 11:8 – RMDIS[3:0] Region Monitoring Disable

Value	Description
0	No effect.
1	When REHASH[i] is written to '1', Region i digest is re-computed. This bit is only available when region monitoring is disabled.

### Bits 7:4 – REHASH[3:0] Recompute Internal Hash

Value	Description
0	No effect.
1	When REHASH[i] is written to '1', Region i digest is re-computed. This bit is only available when region monitoring is disabled.

### Bit 2 – SWRST Software Reset

Value	Description
0	No effect.
1	Resets the ICM controller.

### Bit 1 – DISABLE ECM Disable

Value	Description
0	No effect.
1	The ICM controller is disabled. If a region is activated, the region is terminated.

### Bit 0 – ENABLE ICM Enable

Value	Description
0	No effect.
1	The ICM controller is activated.



### 49.6.3 Status Register

**Name:** SR  
**Offset:** 0x08  
**Property:** Read-Only

Bit	31	30	29	28	27	26	25	24
Access								
Reset								
Bit	23	22	21	20	19	18	17	16
Access								
Reset								
Bit	15	14	13	12	11	10	9	8
	RMDIS[3:0]				RAWRMDIS[3:0]			
Access	R	R	R	R	R	R	R	R
Reset	0	0	0	0	0	0	0	0
Bit	7	6	5	4	3	2	1	0
								ENABLE
Access								R
Reset								0

#### Bits 15:12 – RMDIS[3:0] Region Monitoring Disabled Status

Value	Description
0	Region i is being monitored (occurs after integrity check value has been calculated and written to Hash area).
1	Region i is not being monitored.

#### Bits 11:8 – RAWRMDIS[3:0] Region Monitoring Disabled Raw Status

Value	Description
0	Region i monitoring has been activated by writing a 1 in <a href="#">RMEN[i]</a> of <a href="#">CTRL</a>
1	Region i monitoring has been deactivated by writing a 1 in <a href="#">RMDIS[i]</a> of <a href="#">CTRL</a>

#### Bit 0 – ENABLE ICM Controller Enable Register

Value	Description
0	ICM controller is disabled.
1	ICM controller is activated.

#### 49.6.4 Interrupt Enable Register

**Name:** IER  
**Offset:** 0x10  
**Reset:** 0x00000000  
**Property:** Write-Only

Bit	31	30	29	28	27	26	25	24
								URAD
Access								W
Reset								0
Bit	23	22	21	20	19	18	17	16
	RSU[3:0]				REC[3:0]			
Access	W	W	W	W	W	W	W	W
Reset	0	0	0	0	0	0	0	0
Bit	15	14	13	12	11	10	9	8
	RWC[3:0]				RBE[3:0]			
Access	W	W	W	W	W	W	W	W
Reset	0	0	0	0	0	0	0	0
Bit	7	6	5	4	3	2	1	0
	RDM[3:0]				RHC[3:0]			
Access	W	W	W	W	W	W	W	W
Reset	0	0	0	0	0	0	0	0

**Bit 24 – URAD** Undefined Register Access Detection Interrupt Enable  
0: No effect  
1: The Undefined Register Access interrupt is enabled.

**Bits 23:20 – RSU[3:0]** Region Status Updated Interrupt Enable  
0: No effect  
1: When RSU[i] is written to '1', the region i Status Updated interrupt is enabled.

**Bits 19:16 – REC[3:0]** Region End bit Condition Detected Interrupt Enable  
0: No effect  
1: When REC[i] is written to '1', the region i End bit Condition interrupt is enabled.

**Bits 15:12 – RWC[3:0]** Region Wrap Condition detected Interrupt Enable  
0: No effect  
1: When RWC[i] is written to '1', the Region i Wrap Condition interrupt is enabled.

**Bits 11:8 – RBE[3:0]** Region Bus Error Interrupt Enable

Value	Description
0	No effect.
1	When RBE[i] is written to '1', the Region i Bus Error interrupt is enabled.

**Bits 7:4 – RDM[3:0]** Region Digest Mismatch Interrupt Enable

Value	Description
0	No effect.
1	When RDM[i] is written to '1', the Region i Digest Mismatch interrupt is enabled.

**Bits 3:0 – RHC[3:0]** Region Hash Completed Interrupt Enable

Value	Description
0	No effect.
1	When RHC[i] is written to '1', the Region i Hash Completed interrupt is enabled.

## 49.6.5 Interrupt Disable Register

**Name:** IDR  
**Offset:** 0x14  
**Property:** Write-Only

Bit	31	30	29	28	27	26	25	24
Access								URAD
Reset								W
Bit	23	22	21	20	19	18	17	16
Access	RSU[3:0]				REC[3:0]			
Reset	W	W	W	W	W	W	W	W
Bit	15	14	13	12	11	10	9	8
Access	RWC[3:0]				RBE[3:0]			
Reset	W	W	W	W	W	W	W	W
Bit	7	6	5	4	3	2	1	0
Access	RDM[3:0]				RHC[3:0]			
Reset	W	W	W	W	W	W	W	W

### Bit 24 – URAD Undefined Register Access Detection Interrupt Disable

Value	Description
0	No effect.
1	Undefined Register Access Detection interrupt is disabled.

### Bits 23:20 – RSU[3:0] Region Status Updated Interrupt Disable

Value	Description
0	No effect.
1	When RSU[i] is written to '1', the region i Status Updated interrupt is disabled.

### Bits 19:16 – REC[3:0] Region End bit Condition detected Interrupt Disable

Value	Description
0	No effect.
1	When REC[i] is written to '1', the region i End bit Condition interrupt is disabled.

### Bits 15:12 – RWC[3:0] Region Wrap Condition Detected Interrupt Disable

Value	Description
0	No effect.
1	When RWC[i] is written to '1', the Region i Wrap Condition interrupt is disabled.

### Bits 11:8 – RBE[3:0] Region Bus Error Interrupt Disable

Value	Description
0	No effect.
1	When RBE[i] is written to '1', the Region i Bus Error interrupt is disabled.

### Bits 7:4 – RDM[3:0] Region Digest Mismatch Interrupt Disable

Value	Description
0	No effect.

Value	Description
1	When RDM[i] is written to '1', the Region i Digest Mismatch interrupt is disabled.

**Bits 3:0 – RHC[3:0]** Region Hash Completed Interrupt Disable

Value	Description
0	No effect.
1	When RHC[i] is written to '1', the Region i Hash Completed interrupt is disabled.

## 49.6.6 Interrupt Mask Register

**Name:** IMR  
**Offset:** 0x18  
**Reset:** 0x00000000  
**Property:** Read-Only

Bit	31	30	29	28	27	26	25	24
								URAD
Access								R
Reset								0
Bit	23	22	21	20	19	18	17	16
	RSU[3:0]				REC[3:0]			
Access	R	R	R	R	R	R	R	R
Reset	0	0	0	0	0	0	0	0
Bit	15	14	13	12	11	10	9	8
	RWC[3:0]				RBE[3:0]			
Access	R	R	R	R	R	R	R	R
Reset	0	0	0	0	0	0	0	0
Bit	7	6	5	4	3	2	1	0
	RDM[3:0]				RHC[3:0]			
Access	R	R	R	R	R	R	R	R
Reset	0	0	0	0	0	0	0	0

### Bit 24 – URAD Undefined Register Access Detection Interrupt Mask

Value	Description
0	The interrupt is disabled.
1	The interrupt is enabled.

### Bits 23:20 – RSU[3:0] Region Status Updated Interrupt Mask

Value	Description
0	When RSU[i] is reading '0', the interrupt is disabled for region i.
1	When RSU[i] is reading '1', the interrupt is enabled for region i.

### Bits 19:16 – REC[3:0] Region End bit Condition Detected Interrupt Mask

Value	Description
0	When REC[i] is reading '0', the interrupt is disabled for region i.
1	When REC[i] is reading '1', the interrupt is enabled for region i.

### Bits 15:12 – RWC[3:0] Region Wrap Condition Detected Interrupt Mask

Value	Description
0	When RWC[i] is reading '0', the interrupt is disabled for region i.
1	When RWC[i] is reading '1', the interrupt is enabled for region i.

### Bits 11:8 – RBE[3:0] Region Bus Error Interrupt Mask

Value	Description
0	When RBE[i] is reading '0', the interrupt is disabled for region i.
1	When RBE[i] is reading '1', the interrupt is enabled for region i.

### Bits 7:4 – RDM[3:0] Region Digest Mismatch Interrupt Mask

Value	Description
0	When RDM[i] is reading '0', the interrupt is disabled for region i.
1	When RDM[i] is reading '1', the interrupt is enabled for region i.

**Bits 3:0 – RHC[3:0]** Region Hash Completed Interrupt Mask

Value	Description
0	When RHC[i] is reading '0', the interrupt is disabled for region i.
1	When RHC[i] is reading '1', the interrupt is enabled for region i.

## 49.6.7 Interrupt Status Register

**Name:** ISR  
**Offset:** 0x1C  
**Reset:** 0x0  
**Property:** Read-Only

Bit	31	30	29	28	27	26	25	24
								URAD
Access								R
Reset								0
Bit	23	22	21	20	19	18	17	16
	RSU[3:0]				REC[3:0]			
Access	R	R	R	R	R	R	R	R
Reset	0	0	0	0	0	0	0	0
Bit	15	14	13	12	11	10	9	8
	RWC[3:0]				RBE[3:0]			
Access	R	R	R	R	R	R	R	R
Reset	0	0	0	0	0	0	0	0
Bit	7	6	5	4	3	2	1	0
	RDM[3:0]				RHC[3:0]			
Access	R	R	R	R	R	R	R	R
Reset	0	0	0	0	0	0	0	0

### Bit 24 – URAD Undefined Register Access Detection Status

The URAD bit is only reset by the SWRST bit in the CTRL register.

The Undefined Register Access Trace bit field in the Undefined Access Status Register (UASR.URAT) indicates the unspecified access type.

Value	Description
0	No undefined register access has been detected since the last SWRST.
1	At least one undefined register access has been detected since the last SWRST.

### Bits 23:20 – RSU[3:0] Region Status Updated Detected

RSU[i] is set when a region status updated condition is detected.

### Bits 19:16 – REC[3:0] Region End bit Condition Detected

REC[i] is set when an end bit condition is detected.

### Bits 15:12 – RWC[3:0] Region Wrap Condition Detected

RWC[i] is set when a wrap condition is detected.

### Bits 11:8 – RBE[3:0] Region Bus Error

RBE[i] is set when a bus error is detected while hashing memory region i.

### Bits 7:4 – RDM[3:0] Region Digest Mismatch

RDM[i] is set when there is a digest comparison mismatch between the hash value of region i and the reference value located in the Hash Area.

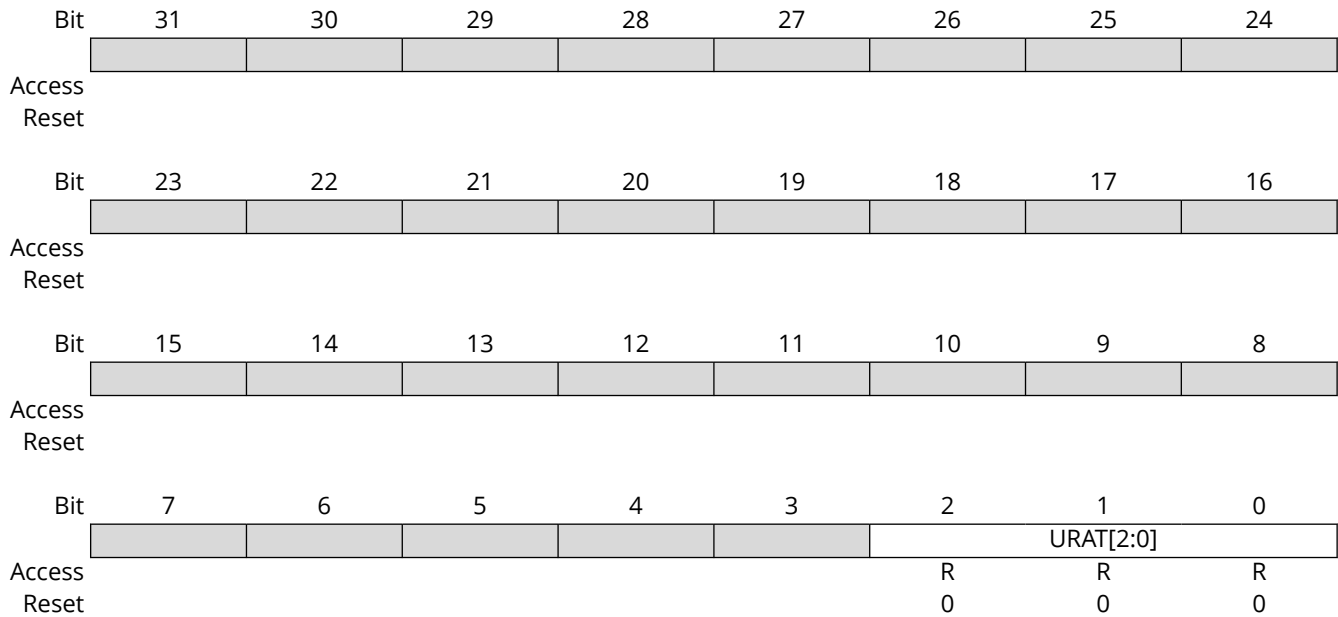
### Bits 3:0 – RHC[3:0] Region Hash Completed

RHC[i] is set when the ICM has completed the region with identifier i.



### 49.6.8 Undefined Access Status Register

**Name:** UASR  
**Offset:** 0x20  
**Reset:** 0x0  
**Property:** Read-Only



#### Bits 2:0 – URAT[2:0] Undefined Register Access Trace

Only the first Undefined Register Access Trace is available through the URAT field.  
 The URAT field is only reset by the Software Reset bit in the Control register (CTRL.SWRST).

Value	Name	Description
0	UNSPEC_STRUCT_MEMBER	Unspecified structure member set to '1' detected when the descriptor is loaded.
1	CFG_MODIFIED	CFG modified during active monitoring.
2	DSCR_MODIFIED	DSCR modified during active monitoring.
3	HASH_MODIFIED	HASH modified during active monitoring.
4	READ_ACCESS	Write-only register read access
		Only the first Undefined Register Access Trace is available through the URAT field. The URAT field is only reset by the SWRST bit in the CTRL register.

## 49.6.9 Descriptor Area Start Address Register

**Name:** DSCR  
**Offset:** 0x30  
**Reset:** 0x0  
**Property:** -

Bit	31	30	29	28	27	26	25	24
	DASA[25:18]							
Access	R/W	R/W	R/W	R/W	R/W	R/W	R/W	R/W
Reset	0	0	0	0	0	0	0	0
Bit	23	22	21	20	19	18	17	16
	DASA[17:10]							
Access	R/W	R/W	R/W	R/W	R/W	R/W	R/W	R/W
Reset	0	0	0	0	0	0	0	0
Bit	15	14	13	12	11	10	9	8
	DASA[9:2]							
Access	R/W	R/W	R/W	R/W	R/W	R/W	R/W	R/W
Reset	0	0	0	0	0	0	0	0
Bit	7	6	5	4	3	2	1	0
	DASA[1:0]							
Access	R/W	R/W						
Reset	0	0						

### Bits 31:6 – DASA[25:0] Descriptor Area Start Address

The start address is a multiple of the total size of the data structure (64 bytes).

### 49.6.10 Hash Area Start Address Register

**Name:** HASH  
**Offset:** 0x34  
**Reset:** 0x00000000  
**Property:** -

Bit	31	30	29	28	27	26	25	24
	HASA[24:17]							
Access	R/W	R/W	R/W	R/W	R/W	R/W	R/W	R/W
Reset	0	0	0	0	0	0	0	0
Bit	23	22	21	20	19	18	17	16
	HASA[16:9]							
Access	R/W	R/W	R/W	R/W	R/W	R/W	R/W	R/W
Reset	0	0	0	0	0	0	0	0
Bit	15	14	13	12	11	10	9	8
	HASA[8:1]							
Access	R/W	R/W	R/W	R/W	R/W	R/W	R/W	R/W
Reset	0	0	0	0	0	0	0	0
Bit	7	6	5	4	3	2	1	0
	HASA[0]							
Access	R/W							
Reset	0							

**Bits 31:7 – HASA[24:0]** Hash Area Start Address

This field points at the Hash memory location. The address must be a multiple of 128 bytes.

### 49.6.11 User Initial Hash Value Register

**Name:** UIHVALn  
**Offset:** 0x38 + n\*0x04 [n=0..7]  
**Reset:** 0  
**Property:** -

Bit	31	30	29	28	27	26	25	24
	VAL[31:24]							
Access	R/W	R/W	R/W	R/W	R/W	R/W	R/W	R/W
Reset	0	0	0	0	0	0	0	0
Bit	23	22	21	20	19	18	17	16
	VAL[23:16]							
Access	R/W	R/W	R/W	R/W	R/W	R/W	R/W	R/W
Reset	0	0	0	0	0	0	0	0
Bit	15	14	13	12	11	10	9	8
	VAL[15:8]							
Access	R/W	R/W	R/W	R/W	R/W	R/W	R/W	R/W
Reset	0	0	0	0	0	0	0	0
Bit	7	6	5	4	3	2	1	0
	VAL[7:0]							
Access	R/W	R/W	R/W	R/W	R/W	R/W	R/W	R/W
Reset	0	0	0	0	0	0	0	0

#### Bits 31:0 – VAL[31:0] Initial Hash Value

When UIHASH bit of CFG register is set, the Initial Hash Value is user-programmable.

To meet the desired standard, use the following example values.

For UIHVAL0 field:

Example	Comment
0x67452301	SHA1 algorithm
0xC1059ED8	SHA224 algorithm
0x6A09E667	SHA256 algorithm

For UIHVAL1 field:

Example	Comment
0xEFCDAB89	SHA1 algorithm
0x367CD507	SHA224 algorithm
0xBB67AE85	SHA256 algorithm

For UIHVAL2 field:

Example	Comment
0x98BADCFE	SHA1 algorithm
0x3070DD17	SHA224 algorithm
0x3C6EF372	SHA256 algorithm

For UIHVAL3 field:

Example	Comment
0x10325476	SHA1 algorithm
0xF70E5939	SHA224 algorithm

.....continued

Example	Comment
0xA54FF53A	SHA256 algorithm

For UIHVAL4 field:

Example	Comment
0xC3D2E1F0	SHA1 algorithm
0xFFC00B31	SHA224 algorithm
0x510E527F	SHA256 algorithm

For UIHVAL5 field:

Example	Comment
0x68581511	SHA224 algorithm
0x9B05688C	SHA256 algorithm

For UIHVAL6 field:

Example	Comment
0x64F98FA7	SHA224 algorithm
0x1F83D9AB	SHA256 algorithm

For UIHVAL7 field:

Example	Comment
0xBEFA4FA4	SHA224 algorithm
0x5BE0CD19	SHA256 algorithm

Example of Initial Value for SHA-1 Algorithm

Register Address	Address Offset / Byte Lane			
	0x3 / 31:24	0x2 / 23:16	0x1 / 15:8	0x0 / 7:0
0x000 UIHVAL0	01	23	45	67
0x004 UIHVAL1	89	ab	cd	ef
0x008 UIHVAL2	fe	dc	ba	98
0x00C UIHVAL3	76	54	32	10
0x010 UIHVAL4	f0	e1	d2	c3

## 50. Hardware Security Module (HSM)

This chapter provides an overview of the Hardware Security Module which is specific to PIC32CX SG60/SG61.

### 50.1 Overview

The Hardware Security Module (HSM) is intended for automotive, industrial, or commercial systems and can provide support for code authentication (secure boot), Message Authentication Code (MAC) generation, support for trusted firmware updates, multiple key management protocols including Transport Layer Security (TLS), and other root-of-trust-based operations.

The HSM serves as a companion device to the MCU.

### 50.2 Features

The following are key features of the HSM module:

- Advanced Crypto Engine (ACE) for Execution of All Cryptography Commands
- Fast Crypto Engine for SHA-256, HMAC and AES-CMAC Algorithms
- Sign/Verify Support:
  - ECDSA – P224, P256, P384, and 256-bit Brainpool elliptic curves
  - ECDSA – SECP256K1 (Bitcoin/Blockchain) curve
  - RSA 2048-bit signature generation and verification
  - RSA 3072-bit signature verification only
- ECDH/ECDHE/ECBD Key Agreement Support:
  - Elliptic-Curve Diffie-Hellman (ECDH) Support for P224, P256, P384, and 256-bit Brainpool
  - Elliptic-Curve Burmester-Desmedt (ECBD) Support for P224 Curve
- Internal Symmetric and Asymmetric Key Generation and Derivation:
  - P224, P256, P384, and 256-Bit Brainpool
  - 2048-bit RSA keys
  - AES 16-byte keys
- AES and RSA Encryption/Decryption Support:
  - AES ECB/GCM Encryption/Decryption Supported directly
  - RSA 1024-bit and 2048-bit Keys Encryption/Decryption Support
- NIST SP800-90 A/B/C Random Number Generator (RNG)
- SPI Client Interface

### 50.3 Applications

- Full and Partial Secure Boot
- Secure Firmware Update
- CAN Message Authentication
- WPC 1.3 Qi High-Power Transmitter Authentication
- High-Bandwidth Digital Content Protection (HDCP) Cryptographic Support
- Network Authentication and Session Establishment using TLS
- Electric Vehicle (EV) Battery Authentication

## 50.4 Signal Description

HSM Interface		PIC32CX SG60/SG61 Interface		
Function	Pin	Pad Name	PORT Configuration	Notes
SPI	MOSI	PB26	Peripheral Function C	SERCOM2 PAD[0]
	MISO	PB28	Peripheral Function C	SERCOM2 PAD[2]
	SCK	PB27	Peripheral Function C	SERCOM2 PAD[1]
	SS	PB29	I/O	General Purpose I/O pin
GPIO	GPIO	PC04	I/O	General Purpose I/O pin

## 50.5 Peripheral Dependencies

### 50.5.1 I/O Lines

In order to use the HSM I/O lines, the SERCOM2 pads must be configured using the [I/O Pin Controller \(PORT\)](#).

### 50.5.2 Power Management

The HSM can continue to operate in any sleep modes.

### 50.5.3 Clocks

The SERCOM2 Clock (CLK\_SERCOM2\_APB) is used by the HSM and must be configured and enabled using the [Generic Clock Controller \(GCLK\)](#) and the [Main Clock Controller \(MCLK\)](#).

### 50.5.4 Debug Operation

When the CPU is halted in Debug mode, the HSM continues its normal operation. The HSM cannot be halted when the CPU is halted in Debug mode.

## 50.6 Functional Description

For additional information, refer to the "PIC32CX SG60/SG61 Hardware Security Module Addendum (DS60001750)" or contact a local Microchip sales office.

## 51. Analog-to-Digital Converter (ADC)

### 51.1 Overview

The Analog-to-Digital Converter (ADC) converts analog signals to digital values. The ADC has up to 12-bit resolution, and is capable of a sampling rate of up to 1 Msps. The input selection is flexible, and both differential and single-ended measurements can be performed. In addition, several internal signal inputs are available. The ADC can provide both signed and unsigned results.

ADC measurements can be started by either application software or an incoming event from another peripheral in the device. ADC measurements can be started with predictable timing and without software intervention.

Both internal and external reference voltages can be used.

The bandgap voltage, as well as the scaled I/O and core voltages, can also be measured by the ADC.

The ADC has a compare function for accurate monitoring of user-defined thresholds, with minimum software intervention required.

The ADC can be configured for 8-bit, 10-bit or 12-bit results. ADC conversion results are provided left-adjusted or right-adjusted, which eases calculation when the result is represented as a signed value. It is possible to use DMA to move ADC results directly to memory or peripherals when conversions are done.

The PIC32CX SG41/SG60/SG61 has two ADC instances, ADC0 and ADC1. The two inputs can be sampled simultaneously, as each ADC includes a dedicated sample and hold (S&H) circuit.

**Note:** When the Peripheral Touch Controller (PTC) is enabled, ADC0 is serving the PTC exclusively. In this case, ADC0 cannot be used by the user application.

### 51.2 Features

The following are key features of the ADC module:

- Two Analog-to-Digital Converter (ADC): ADC0 and ADC1
- 8-bit, 10-bit, or 12-bit resolution
- Up to 1,000,000 samples per second (1Msps)
- Differential and single-ended inputs
  - Up to 23 analog inputs per ADC (16-external channels)  
23 positive and 8 negative, including internal and external
- Internal inputs:
  - Scaled VDDCORE supply
  - Scaled VDD supply
  - Scaled VBAT supply
  - DAC0
- Single, continuous, and sequencing options
- Windowing monitor with selectable channel
- Built-in internal reference and external reference options
- Event-triggered conversion for accurate timing (one event input)
- Optional DMA transfer of conversion settings or result
- Hardware gain and offset compensation
- Averaging and oversampling with decimation to support up to 16-bit result

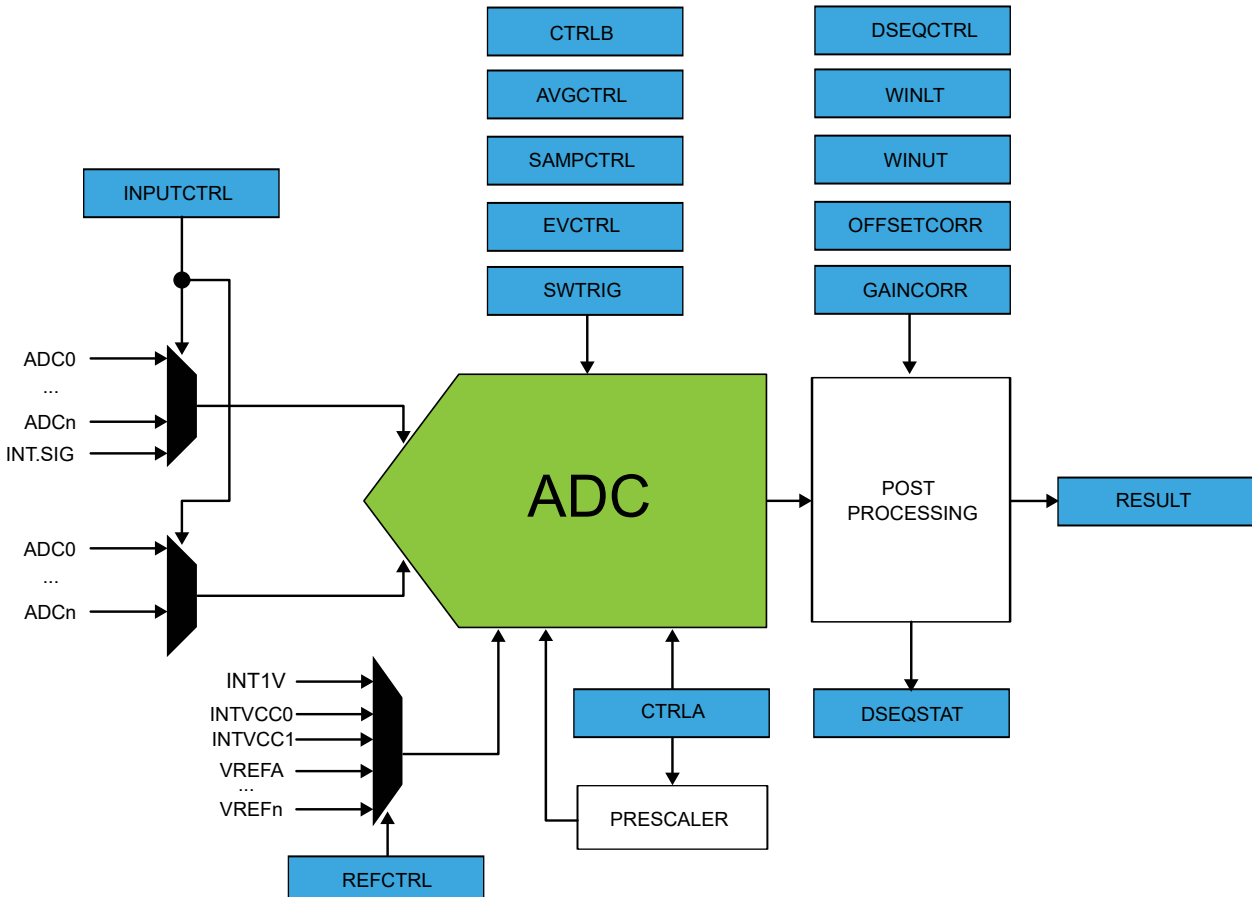


- Selectable sampling time
- Flexible Power or Throughput rate management

ADC0 can be configured to serve the Peripheral Touch Controller (PTC). Refer to the PTC chapter for additional information.

### 51.3 Block Diagram

Figure 51-1. ADC Block Diagram



### 51.4 Signal Description

Signal	Description	Type
VREF[A,B,C]	Analog input	External reference voltage
AIN[15..0]	Analog input	Analog input channels

**Note:** One signal can be mapped on several pins.

### 51.5 Peripheral Dependencies

<b>Peripheral Name</b>	ADC0 – Analog-to-Digital Converter 0
<b>Base Address</b>	0x4300_1C00 (Peripheral Bus D)
<b>NVIC IRQ Index:Source</b>	118 : OVERRUN, WINMON; 119 : RESRDY
<b>MCLK APB Clock (1)</b>	CLK_ADC0_APB, Disabled, APBDMASK.ADC0
<b>GCLK Peripheral Channel Index:Clock Name (2)</b>	40 : GCLK_ADC0
<b>PAC Peripheral Identifier (PAC.WRCTRL)</b>	103

<b>DMA Trigger Index:Source (DMAC.CHCTRLAk,k=0,1,...31)</b>	68 : RESRDY, 69 : SEQ
<b>EVSYS Users (EVSYS.USERm) (3)</b>	55 : Start Conversion (ADC0 START) (A,S,R) 56 : Flush ADC0 (ADC0 SYNC) (A,S,R)
<b>EVSYS Generators (EVSYS.CHANNELn)</b>	103 : Result Ready (ADC0_RESRDY) 104 : Window Monitor (ADC0_WINMON)

<b>Peripheral Name</b>	ADC1 – Analog-to-Digital Converter 1
<b>Base Address</b>	0x4300_2000 (Peripheral Bus D)
<b>NVIC IRQ Index:Source</b>	120 : OVERRUN, WINMON; 121 : RESRDY
<b>MCLK APB Clock (1)</b>	CLK_ADC1_APB, Disabled, APBDMASK.ADC1
<b>GCLK Peripheral Channel Index:Clock Name (2)</b>	41 : GCLK_ADC1
<b>PAC Peripheral Identifier (PAC.WRCTRL)</b>	104
<b>DMA Trigger Index:Source (DMAC.CHCTRLAk,k=0,1,...31)</b>	70 : RESRDY, 71 : SEQ
<b>EVSYS Users (EVSYS.USERm) (3)</b>	57 : Start Conversion (ADC1 START) (A,S,R) 58 : Flush ADC1 (ADC1 SYNC) (A,S,R)
<b>EVSYS Generators (EVSYS.CHANNELn)</b>	105 : Result Ready (ADC1_RESRDY) 106 : Window Monitor (ADC1_WINMON)

**Notes:**

1. Clock Name, Default State, Mask Field.
2. See GCLK.PCHCTRLm Register, where m = Index.
3. (A,S,R): A = Asynchronous path, S = Synchronous path, R = Resynchronized path.

### 51.5.1 Power Management

The ADC will continue to operate in any Sleep mode where the selected source clock is running. The ADC's interrupts, except the OVERRUN interrupt, can be used to wake up the device from sleep modes. Events connected to the event system can trigger other operations in the system without exiting sleep modes.

### 51.5.2 Clocks

The ADC bus clocks (CLK\_APB\_ADCx) can be enabled in the [Main Clock](#), which also defines the default state.

Each ADC requires a generic clock (GCLK\_ADCx). This clock must be configured and enabled in the [Generic Clock Controller \(GCLK\)](#) before using the ADC.

A generic clock is asynchronous to the bus clock. Due to this asynchronicity, writes to certain registers will require synchronization between the clock domains. Refer to [Synchronization](#) for additional information.

### 51.5.3 Debug Operation

When the CPU is halted in debug mode the ADC will halt normal operation. The ADC can be forced to continue operation during debugging. Refer to [DBGCTRL](#) register for details.

### 51.5.4 Register Access Protection

All registers with write-access are optionally write-protected by the [Peripheral Access Controller \(PAC\)](#), except the following register:

- Interrupt Flag Status and Clear (INTFLAG) register

Optional write protection by the [Peripheral Access Controller \(PAC\)](#) is denoted by the "PAC Write Protection" property in each individual register description.

PAC write protection does not apply to accesses through an external debugger.

### 51.5.5 Analog Connections

I/O-pins (AINx), as well as the VREFA/VREFB/VREFC reference voltage pins are analog inputs to the ADC. Any internal reference source, such as a bandgap voltage reference, or DAC must be configured and enabled prior to its use with the ADC.

### 51.5.6 Calibration

The BIASREFBUF, BIASR2R and BIASCOMP calibration values from the production test must be loaded from the [NVM Software Calibration Area](#) into the ADC Calibration register (CALIB) by software to allow conversion and to achieve specified accuracy.

## 51.6 Functional Description

### 51.6.1 Principle of Operation

By default, the ADC provides results with 12-bit resolution. 8-bit or 10-bit results can be selected in order to reduce the conversion time, see [51.6.2.8. Conversion Timing and Sampling Rate](#).

The ADC has an oversampling with decimation option that can extend its resolution to 16 bits. The input values can be either internal or external (connected I/O pins). The user can also configure whether the conversion should be single-ended or differential.

### 51.6.2 Basic Operation

#### 51.6.2.1 Initialization

The following registers are enable-protected, meaning that they can only be written when the ADC is disabled (CTRLA.ENABLE = 0):

- The Control A register (CTRLA), except the ENABLE and SWRST bits
- The Event Control register (EVCTRL)
- The Calibration register (CALIB)

Enable-protection is denoted by the "Enable-Protected" property in the register description.

#### 51.6.2.2 Enabling, Disabling, and Resetting

The ADC is enabled by writing a '1' to the Enable bit in the Control A register (CTRLA.ENABLE). The ADC is disabled by writing CTRLA.ENABLE = 0.

The ADC is reset by writing a '1' to the Software Reset bit in the Control A register (CTRLA.SWRST). All registers in the ADC, except DBGCTRL, will be reset to their initial state, and the ADC will be disabled. Refer to [51.7.1. CTRLA](#) for additional information

#### 51.6.2.3 Operation

In the most basic configuration, the ADC samples values from the configured internal or external sources (INPUTCTRL register). The rate of the conversion depends on the combination of the GCLK\_ADCx frequency and the clock prescaler.

To convert analog values to digital values, the ADC needs to be initialized first, as described in the Initialization section. Data conversion can be started either manually by setting the Start bit in the Software Trigger register (SWTRIG.START=1), or automatically by configuring an automatic trigger to initiate the conversions. The ADC starts sampling the input only after the start of conversion is triggered. This means that even after the MUX selection is made, sample and hold (S&H) operation starts only on the conversion trigger. A free-running mode can be used to continuously convert an input channel. When using free-running mode the first conversion must be started, while subsequent conversions will start automatically at the end of the previous conversion.

The ADC starts sampling the input only after the start of a conversion is triggered. This means that even after the MUX selection is made, sample and hold operation starts only on the conversion trigger.

The result of the conversion is stored in the Result register (RESULT) overwriting the result from the previous conversion.

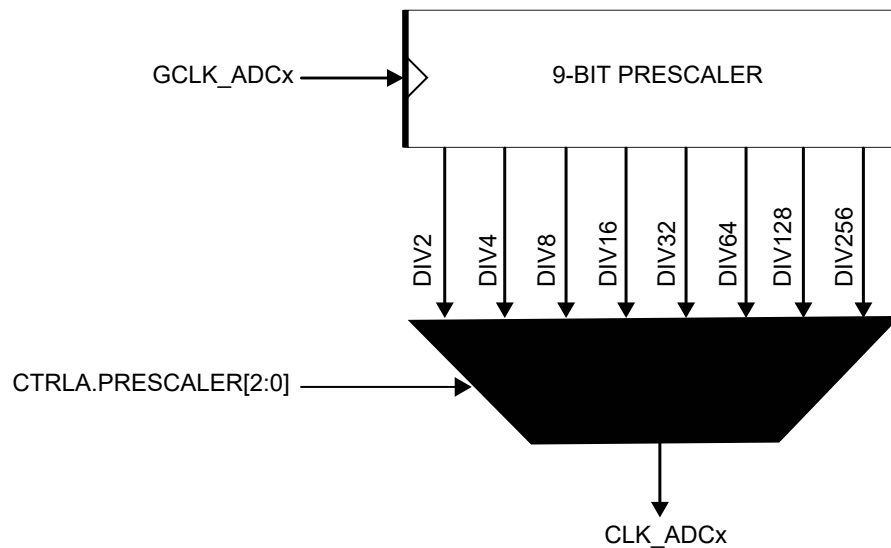
To avoid data loss, if more than one channel is enabled, the conversion result must be read as soon as it is available (INTFLAG.RESRDY). Failing to do so will result in an overrun error condition, indicated by the OVERRUN bit in the Interrupt Flag Status and Clear register (INTFLAG.OVERRUN).

To enable one of the available interrupts sources, the corresponding bit in the Interrupt Enable Set register (INTENSET) must be written to '1'.

#### 51.6.2.4 Prescaler Selection

The ADC is clocked by GCLK\_ADCx. There is also a prescaler in the ADC to enable conversion at lower clock rates. Refer to CTRLA for details on prescaler settings. Refer to [51.6.2.8. Conversion Timing and Sampling Rate](#) for details on timing and sampling rate.

Figure 51-2. ADC Prescaler



**Note:** The minimum prescaling factor is DIV2.

#### 51.6.2.5 Reference Configuration

The ADC has various sources for its reference voltage  $V_{REF}$ . The Reference Voltage Selection bit field in the Reference Control register (REFCTRL.REFSEL) determines which reference is selected. By default, the internal voltage reference (VREF) is selected. Based on customer application requirements, the external or internal reference can be selected. Refer to REFCTRL.REFSEL for further details on available selections.

**Note:** If the internal bandgap voltage reference is selected (REFCTRL.REFSEL = 0x0), the On Demand operation mode (CTRLA.ONDEMAND= 0) is not supported and a delay of minimum 40 $\mu$ s must be respected between the enable of the ADC (CTRLA.ENABLE) and the start of the first conversion. In case an ADC conversion is triggered by an input event, the delay must be introduced between the enable of the ADC and the enable of the ADC EVSYS channel.

#### 51.6.2.6 ADC Resolution

The ADC supports 8-bit, 10-bit or 12-bit resolution. Resolution can be changed by writing the Resolution bit group in the Control B register (CTRLB.RESSEL). By default, the ADC resolution is set to 12 bits. The resolution affects the propagation delay, see also [51.6.2.8. Conversion Timing and Sampling Rate](#).

#### 51.6.2.7 Differential and Single-Ended Conversions

The ADC has two conversion options: differential and single-ended.

If the positive input is always positive, the single-ended conversion must be used to have full 12-bit resolution in the conversion. If the positive input level may go below the negative input, the differential mode must be used to get correct results.

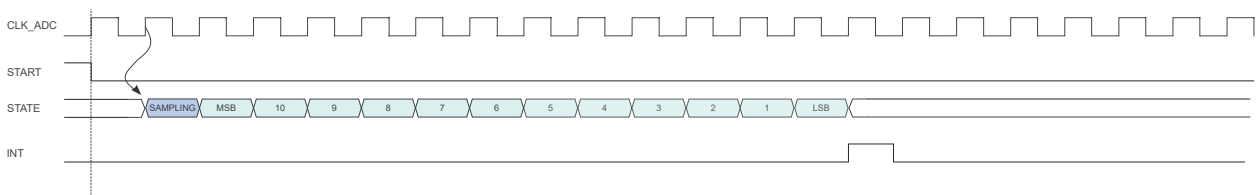
The differential mode is enabled by writing a '1' to the DIFFMODE bit in the input control register (INPUTCTRL.DIFFMODE).

Both conversion types could be run in single mode or in free-running mode. When the free-running mode is selected, an ADC input will continuously sample the input and performs a new conversion. The INTFLAG.RESRDY bit will be set at the end of each conversion.

### 51.6.2.8 Conversion Timing and Sampling Rate

The following figure shows the ADC timing for a single conversion. A conversion starts after the software or event start are synchronized with the GCLK\_ADCx clock. The input channel is sampled in the first half CLK\_ADCx period.

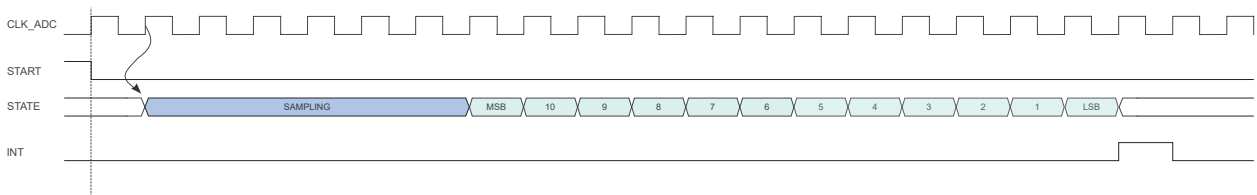
**Figure 51-3.** ADC Timing for One Conversion in 12-bit Resolution



Refer to the ADC Sample Timing Requirements table in the “Electrical Characteristics” chapters to get the different conversion times for 8-bit, 10-bit, and 12-bit resolution.

The sampling time can be increased by using the Sampling Time Length bit group in the Sampling Time Control register (SAMPCTRL.SAMPLEN). As example, the next figure is showing the timing conversion with sampling time increased to six CLK\_ADC cycles.

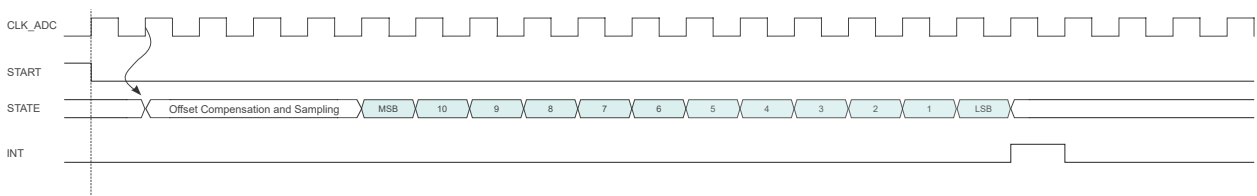
**Figure 51-4.** ADC Timing for One Conversion with Increased Sampling Time, 12-bit



The ADC can also provide offset compensation, as shown in the following figure. The offset compensation is enabled by the Offset Compensation bit in the Sampling Control register (SAMPCTRL.OFFCOMP).

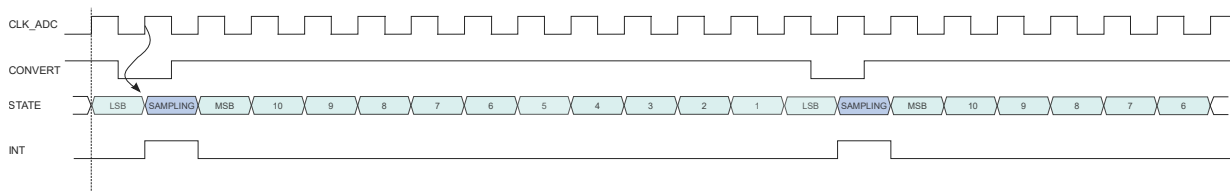
**Note:** ADC sampling time is fixed to 4 ADC Clock cycles when offset compensation (OFFCOMP=1) is used.

**Figure 51-5.** ADC Timing for One Conversion with Offset Compensation, 12-bit



The following figure shows the ADC timing for free-running mode conversion.

**Figure 51-6.** ADC Timing for Free Running in 12-bit Resolution



In free running mode, the sampling rate  $R_S$  is calculated by:

$$R_S = f_{CLK\_ADC} / (n_{SAMPLING} + n_{OFFCOMP} + n_{DATA})$$

Where,

$n_{SAMPLING}$  is the sampling duration in CLK\_ADC cycles,  $n_{OFFCOMP}$  is the offset compensation duration in clock cycles, and  $n_{DATA}$  is the bit resolution.  $f_{CLK\_ADC}$  is the ADC clock frequency from the internal prescaler:  $f_{CLK\_ADC} = f_{GCLK\_ADC} / 2^{(1 + CTRLA.PRESCALER)}$

The propagation delay of an ADC measurement is given by:

$$\text{PropagationDelay} = \frac{1 + \text{Resolution}}{f_{ADC}}$$

**Example.** In order to obtain 1 MSPS in 12-bit resolution with a sampling time length of four CLK\_ADC cycles,  $f_{CLK\_ADC}$  must be  $1 \text{ MSPS} * (4 + 12) = 16 \text{ MHz}$ . As the minimal division factor of the prescaler is 2, GCLK\_ADC must be 32 MHz.

### 51.6.2.9 Accumulation

The results of multiple, consecutive conversions can be accumulated. The number of samples to be accumulated is specified by the Sample Number field in the Average Control register (AVGCTRL.SAMPLENUM). When accumulating more than 16 samples, the result will be too large to fit the 16-bit RESULT register size. To avoid overflow, the result is right shifted automatically to fit within the available register size. The number of automatic right shifts is specified in the table below.

**Note:** To perform the accumulation of two or more samples, the Conversion Result Resolution field in the Control B register (CTRLB.RESSEL) must be set.

**Table 51-1.** Accumulation

Number of Accumulated Samples	AVGCTRL.SAMPLENUM	Number of Automatic Right Shifts	Final Result Precision	Automatic Division Factor
1	0x0	0	12 bits	0
2	0x1	0	13 bits	0
4	0x2	0	14 bits	0
8	0x3	0	15 bits	0
16	0x4	0	16 bits	0
32	0x5	1	16 bits	2
64	0x6	2	16 bits	4
128	0x7	3	16 bits	8
256	0x8	4	16 bits	16
512	0x9	5	16 bits	32
1024	0xA	6	16 bits	64
Reserved	0xB–0xF		12 bits	0

### 51.6.2.10 Averaging

Averaging is a feature that increases the sample accuracy, at the cost of a reduced sampling rate. This feature is suitable when operating in noisy conditions.

Averaging is done by accumulating  $m$  samples, as described in 51.6.2.9. Accumulation, and dividing the result by  $m$ . The averaged result is available in the RESULT register. The number of samples to be accumulated is specified by writing to AVGCTRL.SAMPLENUM as shown in Table 51-2.

The division is obtained by a combination of the automatic right shift described above, and an additional right shift that must be specified by writing to the Adjusting Result/Division Coefficient field in AVGCTRL (AVGCTRL.ADJRES), as described in Table 51-2.

**Note:** To perform the averaging of two or more samples, the Conversion Result Resolution field in the Control B register (CTRLB.RESSEL) must be set.

Averaging AVGCTRL.SAMPLENUM samples will reduce the un-averaged sampling rate by a factor  $\frac{1}{\text{AVGCTRL.SAMPLENUM}}$ .

When the averaged result is available, the INTFLAG.RESRDY bit will be set.

**Table 51-2.** Averaging

Number of Accumulated Samples	AVGCTRL.SAMPLENUM	Intermediate Result Precision	Number of Automatic Right Shifts	Division Factor	AVGCTRL.ADJRES	Total Number of Right Shifts	Final Result Precision	Automatic Division Factor
1	0x0	12 bits	0	1	0x0		12 bits	0
2	0x1	13	0	2	0x1	1	12 bits	0
4	0x2	14	0	4	0x2	2	12 bits	0
8	0x3	15	0	8	0x3	3	12 bits	0
16	0x4	16	0	16	0x4	4	12 bits	0
32	0x5	17	1	16	0x4	5	12 bits	2
64	0x6	18	2	16	0x4	6	12 bits	4
128	0x7	19	3	16	0x4	7	12 bits	8
256	0x8	20	4	16	0x4	8	12 bits	16
512	0x9	21	5	16	0x4	9	12 bits	32
1024	0xA	22	6	16	0x4	10	12 bits	64
Reserved	0xB–0xF				0x0		12 bits	0

### 51.6.2.11 Oversampling and Decimation

By using oversampling and decimation, the ADC resolution can be increased from 12 bits up to 16 bits, for the cost of reduced effective sampling rate.

**Note:** To perform oversampling and decimation, the Conversion Result Resolution field in the Control C register (CTRLC.RESSEL) must be set to 16-bit mode.

To increase the resolution by ‘ $n$ ’ bits,  $4^n$  samples must be accumulated. The result must then be right shifted by ‘ $n$ ’ bits. This right shift is a combination of the automatic right shift and the value written to AVGCTRL.ADJRES. To obtain the correct resolution, the ADJRES must be configured as described in the table below. This method will result in ‘ $n$ ’ bit extra LSB resolution.

**Table 51-3.** Configuration Required for Oversampling and Decimation

Result Resolution	Number of Samples to Average	AVGCTRL.SAMPLENUM[3:0]	Number of Automatic Right Shifts	AVGCTRL.ADJRES[2:0]
13 bits	$4^1 = 4$	0x2	0	0x1
14 bits	$4^2 = 16$	0x4	0	0x2

.....continued

Result Resolution	Number of Samples to Average	AVGCTRL.SAMPLENUM[3:0]	Number of Automatic Right Shifts	AVGCTRL.ADJRES[2:0]
15 bits	$4^3 = 64$	0x6	2	0x1
16 bits	$4^4 = 256$	0x8	4	0x0

### 51.6.2.12 Window Monitor

The window monitor feature allows comparing the conversion result in the RESULT register to predefined threshold values.

The window mode is selected by writing the Window Monitor Mode bits in the Control B register (CTRLB.WINMODE). Threshold values must be written in the Window Monitor Lower Threshold register (WINLT) and Window Monitor Upper Threshold register (WINUT).

When the Window Single Sample (CTRLB.WINSS) bit is written to '1', the window comparator is working on each sample instead of the accumulated value. The number of samples matching with window comparator is available on Window Comparator Counter bits (STATUS.WCC).

In differential mode, WINLT and WINUT are evaluated as signed values. Otherwise they are evaluated as unsigned values. The significant WINLT and WINUT bits are given by the precision selected in the Conversion Result Resolution bit group in the Control B register (CTRLB.RESSEL). This means that for example in 8-bit mode, only the eight lower bits will be considered. In addition, in differential mode, the eighth bit will be considered as the sign bit, even if the ninth bit is zero.

The INTFLAG.WINMON interrupt flag is set when either the conversion result matches the window monitor condition, when the Window Comparator Counter is not zero in case of accumulation with CTRLB.WINSS=1.

### 51.6.2.13 Offset and Gain Correction

Inherent gain and offset errors affect the absolute accuracy of the ADC.

The offset error is defined as the deviation of the actual ADC transfer function from an ideal straight line at zero input voltage. The offset error cancellation is handled by the Offset Correction register (OFFSETCORR). The offset correction value is subtracted from the converted data before writing the Result register (RESULT).

The gain error is defined as the deviation of the last output step's midpoint from the ideal straight line, after compensating for offset error. The gain error cancellation is handled by the Gain Correction register (GAINCORR).

To correct these two errors, the Digital Correction Logic Enabled bit in the Control B register (CTRLB.CORREN) must be set.

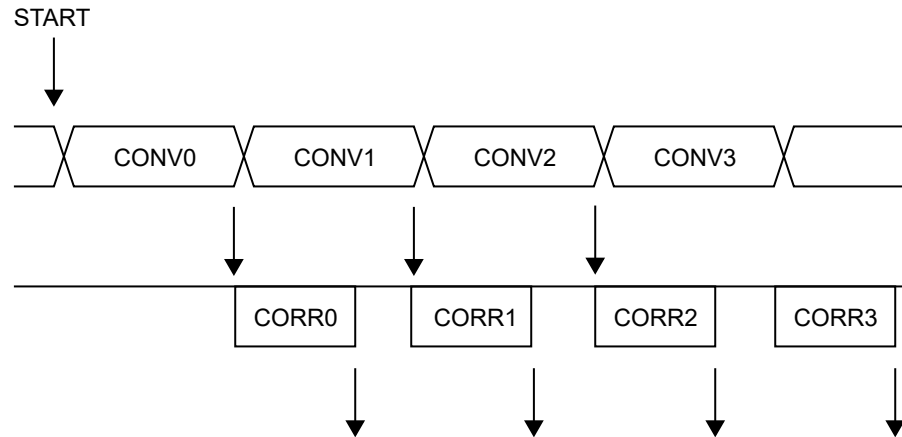
Offset and gain error compensation results are both calculated according to:

$$\text{Result} = (\text{Conversion value} + \text{OFFSETCORR}) \cdot \text{GAINCORR}$$

The correction will introduce a latency of 13 CLK\_ADC clock cycles. In free running mode this latency is introduced on the first conversion only, since its duration is always less than the propagation delay. In single conversion mode this latency is introduced for each conversion.



**Figure 51-7. ADC Timing Correction Enabled**



#### 51.6.2.14 Reference Buffer Compensation Offset

A hardware compensation using a reference buffer can be used. When the REFCTRL.REFCOMP bit is set, the offset of the reference buffer is sensed during the ADC sampling phase. This offset will then be canceled during the conversion phase. This feature allows for the decrease of the overall gain error of the ADC.

There is a digital gain correction (refer to Offset and Gain Correction) but contrary to that digital gain correction, the hardware compensation will not introduce any latency.

**Note:** If the reference buffer offset compensation is enabled (REFCOMP=1) and the ADC reference selection is not using VDDANA (REFSEL != INTVCC1), the first 5 conversions of the ADC must be discarded after the ADC is enabled.

### 51.6.3 Additional Features

#### 51.6.3.1 Rail-to-Rail Operation

The accuracy of the ADC is highest when the input common mode voltage (VCMIN) is close to VREF/2. To enable a full range of common mode voltages (rail-to-rail operation), the Rail-to-Rail bit in the Control C register (CTRLA.R2R) must be written to one. The Rail-to-Rail operation requires a sampling period of four cycles, and this is achieved by enabling offset compensation (SAMPCTRL.OFFCOMP = 1). The Rail-to-Rail operation should not be used when offset compensation is disabled.

#### 51.6.3.2 Double Buffering

The following registers are double buffered:

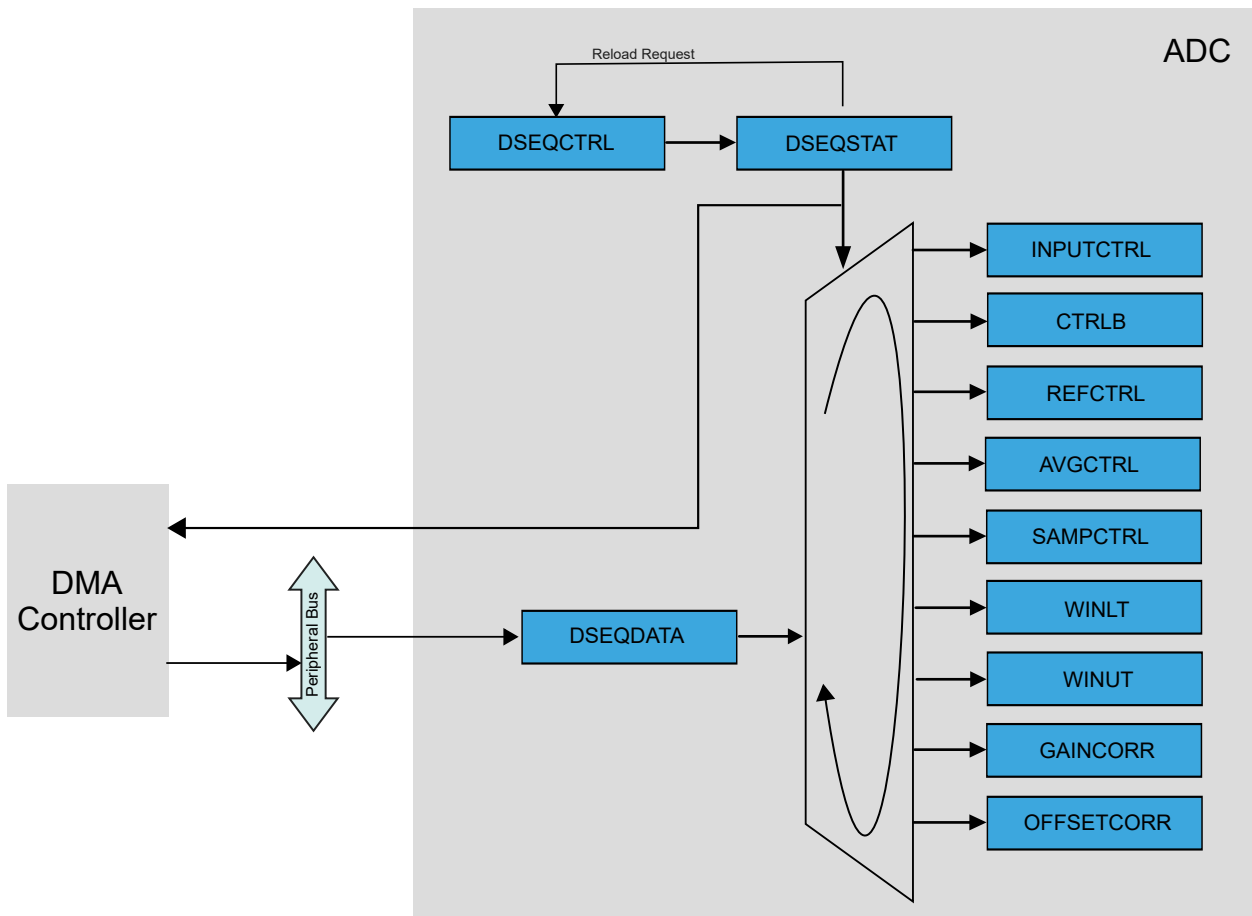
- Input Control (INPUTCTRL)
- Control B (CTRLB)
- Reference Control (REFCTRL)
- Average Control (AVGCTRL)
- Sampling Time Control (SAMPCTRL)
- Window Monitor Lower Threshold (WINLT)
- Window Monitor Upper Threshold (WINUT)
- Gain Correction (GAINCORR)
- Offset Correction (OFFSETCORR)

When one of these registers is written, the data is stored in the corresponding buffer as long as the current conversion is not impacted, and the corresponding busy status will be set in the

Synchronization Busy register (SYNCBUSY). When a new RESULT is available, data stored in the buffer registers will be transferred to the ADC and a new conversion can start.

### 51.6.3.3 DMA Sequencing

The ADC can sequence a series of conversion. When DMA sequencing is enabled, a set of ADC configuration registers can be automatically refreshed using the [DMA controller](#).



#### Enabling DMA Sequencing

DMA Sequencing is enabled when at least one bit in the DMA Sequence Control register (DSEQCTRL) is '1'.

When this is the case, the BUSY status bit in the DMA Sequential Status register (DSEQSTAT.BUSY) is set to '1'.

**Note:** ADC DMA Sequencing operations are limited to DIV2, DIV4 and DIV8 prescalers configuration.

#### Disabling DMA Sequencing

DMA Sequencing is disabled when at least one of the following conditions is valid:

- The ADC is disabled (CTRLA.ENABLE = 0).
- The ADC is reset (CTRLA.SWRST = 1).
- The DMA Sequence Control register (DSEQCTRL) is written '0' and the ongoing DMA sequence is completed.
- The DMA Sequencing Stop bit in Input Control register is '1' (INPUTCTRL.DSEQSTOP = 1) and the ongoing DMA sequence is complete. One additional measurement will be done before the ADC is disabled.

When the DMA sequencing is disabled, the BUSY status bit in the DMA Sequential Status register (DSEQSTAT.BUSY) is cleared and the DMA trigger generation is disabled.

Note that if the DSEQCTRL register is written to a non-zero value, the DSEQSTOP bit in the INPUTCTRL register will be cleared and the sequencing operation will not be stopped.

### Restarting DMA Sequencing

When the DSEQSTOP bit is set (INPUTCTRL.DSEQSTOP = 1) and the sequence is disabled (DSEQSTAT.BUSY=0), it is possible to restart the sequencing by enabling one of the following conditions:

- Write the DSEQSTOP bit in Input Control register to zero (INPUTCTRL.DSEQSTOP = 0)
- Apply a FLUSH software command (SWTRIG.FLUSH = 1)
- Enable the flush event (EVCTRL.FLUSHEI). The sequence will restart when the flush event is received

### DMA Sequencing Operation

Each ADC register that is part of the DMA sequencing has a separate enable bit in the DSEQCTRL register to indicate that this field should be part of the DMA sequencing. When an enable bit in DSEQCTRL is '1', the respective register will be updated when an access to DSEQDATA is decoded.

The DMA Sequencing (DSEQ) trigger request is generated when BUSY status bit is one (DSEQSTAT.BUSY=1), the ADC is idle or a new conversion starts, and one of the following condition is true:

- Input Control or Control B bits in DMA Sequential Control register is '1' (DSEQCTRL.INPUTCTRL=1 or DSEQCTRL.CTRLB=1)
- Reference Control, Sampling Time Control or Average Control bits in DMA Sequential Control register is set (DSEQCTRL.REFCTRL=1, DSEQCTRL.AVGCTRL=1 or DSEQCTRL.SAMPCTRL=1)
- Window Monitor Upper Threshold or Window Monitor Lower Threshold bits in DMA Sequential Control register is set (DSEQCTRL.WINUT=1 or DSEQCTRL.WINLT=1)
- Offset Correction or Gain Correction bits in DMA Sequential Control register is set (DSEQCTRL.GAINCORR=1 or DSEQCTRL.OFFSETCORR=1)

**Note:** When received, the DMA data must be written to DSEQDATA register only, and only 32-bit DMA access is supported.

If a field is not enabled for DMA update, the corresponding register update will be ignored when DSEQDATA register is written. The table below shows the DSEQ trigger generation condition and internal ADC registers refresh when the DSEQDATA register is written by the DMA.

**Table 51-4.** DSEQ Trigger Generation and Internal ADC Register updates

Condition	Value	Action when DMA writes to DSEQDATA
DSEQSTAT.REFCTRL or DSEQSTAT.SAMPCTRL	0	<ul style="list-style-type: none"> <li>• No DMA trigger is generated</li> <li>• No data in the memory must be reserved</li> </ul>
DSEQSTAT.REFCTRL or DSEQSTAT.AVGCTRL or DSEQSTAT.SAMPCTRL	1	<ul style="list-style-type: none"> <li>• A DMA trigger is generated</li> <li>• One word (32-bit) must be reserved in the memory</li> <li>• REFCTRL ← DSEQDATA[7:0] if DSEQSTAT.REFCTRL = 1</li> <li>• AVGCTRL ← DSEQDATA[23:16] if DSEQSTAT.AVGCTRL = 1</li> <li>• SAMPCTRL ← DSEQDATA[31:24] if DSEQSTAT.SAMPCTRL = 1</li> </ul>

.....continued		
Condition	Value	Action when DMA writes to DSEQDATA
DSEQSTAT.WINLT or DSEQSTAT.WINUT	0	<ul style="list-style-type: none"> <li>No DMA trigger is generated</li> <li>No data in the memory must be reserved</li> </ul>
	1	<ul style="list-style-type: none"> <li>A DMA trigger is generated</li> <li>One word (32-bit) must be reserved in the memory</li> <li>WINLT ← DSEQDATA[15:0] if DSEQSTAT.WINLT = 1</li> <li>WINUT ← DSEQDATA[31:16] if DSEQSTAT.WINUT = 1</li> </ul>
DSEQSTAT.GAINCORR or DSEQSTAT.OFFSETCORR	0	<ul style="list-style-type: none"> <li>No DMA trigger is generated</li> <li>No data in the memory must be reserved</li> </ul>
	1	<ul style="list-style-type: none"> <li>A DMA trigger is generated</li> <li>One word (32-bit) must be reserved in the memory</li> <li>GAINCORR ← DSEQDATA[15:0] if DSEQSTAT.GAINCORR = 1</li> <li>OFFSETCORR ← DSEQDATA[31:16] if DSEQSTAT.OFFSETCORR = 1</li> </ul>

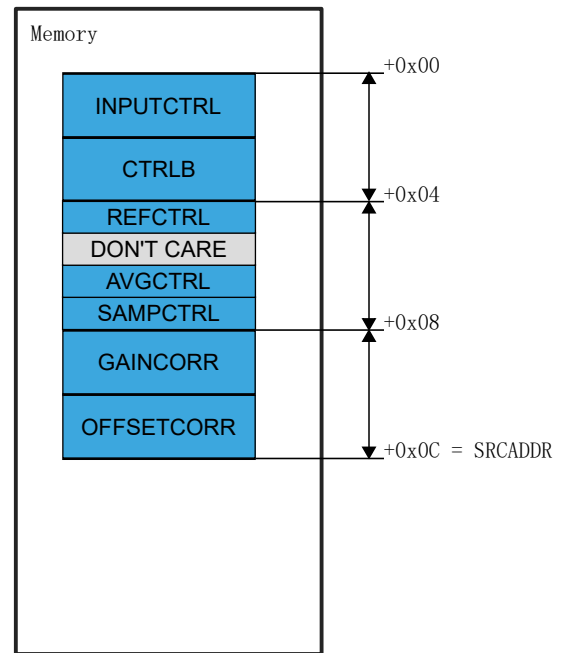
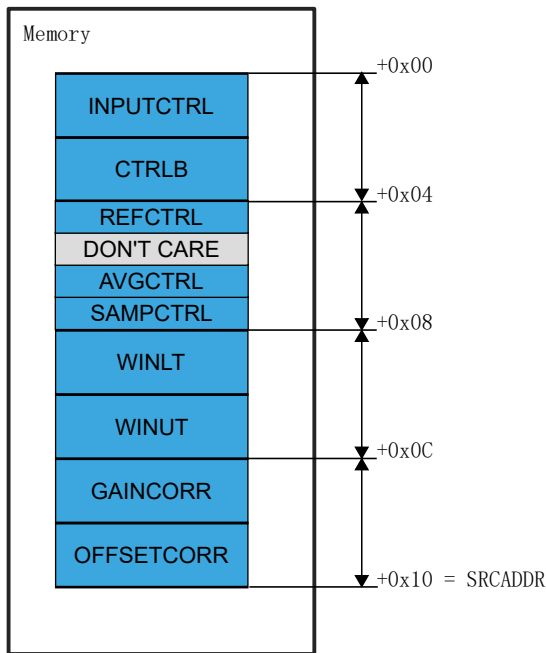
The DMA Sequential Status register (DSEQSTAT) stores the remaining registers to be updated by the DMA. During a sequence and when a write access to the DSEQDATA register is detected, the DSEQSTAT bits which were source of the corresponding DSEQ trigger will be cleared. When all DSEQSTAT bits are zero (except BUSY bit), the DSEQCTRL register bits (except AUTOSTART) are copied into the DSEQSTAT register and a new DMA sequence is started when a new ADC conversion starts.

### DMA Descriptor Setup and Data Memory Organization

When DMA sequencing is enabled, the DMA Controller (DMAC) must be configured in the following way:

- Select 32-bit beat size transfer (DMAC.BTCTRL.BEATSIZE=WORD).
- Enable the source address increment options (DMAC.BTCTRL.SRCINC = 1, DMAC.BTCTRL.STEPSEL = SRC, DMAC.BTCTRL.STEPSIZE = X1).
- Disable the destination address increment (DMAC.BTCTRL.DSTINC=0).
- Set the block transfer count value (DMAC.BTCNT).
- Set the block transfer source address (DMAC.SRCADDR), as described in the DMAC Addressing section. The address corresponds to the memory section from where the DMA reads the data.
- Select the ADC.DSEQDATA address as value for the block transfer destination address (DMAC.DSTADDR = ADC.DSEQDATA address).
- Select the channel single transfer type (DMAC.CHCTRLA.BURSTLEN=SINGLE)
- Select the channel burst trigger action (DMAC.CHCTRLA.TRIGACT=BURST)
- Select the ADC DMA Sequencing trigger as channel trigger source (DMAC.CHCTRLA.TRIGSRC=DSEQ)
- Enable optional channel interrupts (DMAC.CHINTENSET)
- Enable the corresponding DMA channel (DMAC.CHCTRLA.ENABLE)

When an ADC condition is enabled to trigger a DMA transfer, one word (32-bit) will be read by the DMA from the memory source location. Since the source address is incrementing by 0x1, the data memory must be organized in a contiguous memory area. As consequence, if an ADC group of registers does not generate any DMA trigger, no data must be reserved in the memory area for this register group. The next figure shows an example of memory organization when all ADC registers are part of the sequence, and a second example where WINLT and WINUT registers are not part of the sequence.



All registers are in the sequence

WINLT / WINUT registers are not in the sequence

### Automatic Start Conversion

By default, a new conversion starts when a new start software or event trigger is received. It is also possible to automatically enable an ADC conversion by writing '1' to the AUTOSTART bit in DSEQCTRL register (DSEQCTRL.AUTOSTART). When set, the ADC automatically starts a new conversion when a DMA sequence is complete.

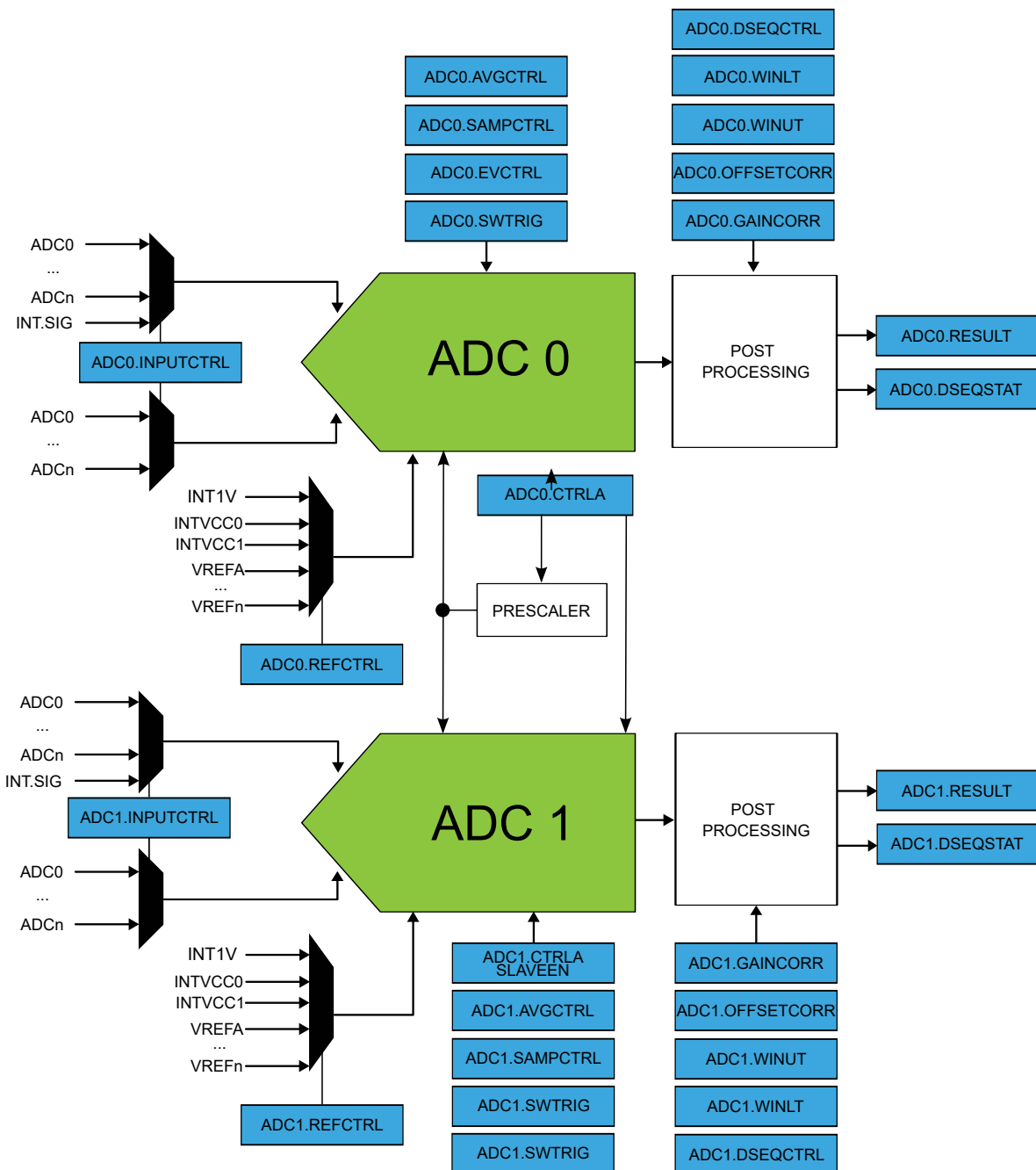
**Note:** If averaging or oversampling is enabled, the new conversion automatically starts only when the previous RESULT is available (averaging or oversampling operation is complete).

**Note:** Free run mode (CTRLB.FREERUN=1) can not be used with DMA sequencing.

**Note:** If the conversion is triggered by event (EVCTRL.STARTEI=1), the automatic start conversion is disabled and the AUTOSTART settings are ignored.

### 51.6.3.4 Host - Client Operation

ADC1 will serve as a Client of ADC0 by writing a '1' to the Client Enable bit in the Control A register of the ADC1 instance (ADC1.CTRLA.SLAVEEN). When enabled, GCLK\_ADC0 clock and ADC0 controls are internally routed to the ADC1 instance.



In this mode of operation, the Client ADC1 is enabled by accessing the CTRLA register of the Host ADC0. In the same way, the Host ADC event inputs will be automatically routed to the Client ADC, meaning that the input events configuration must be done in the Host ADC (ADC0.EVCTRL).

**Note:** To enable DMA sequencing for the ADC1 (Client), the ADC0 (Host) must be enabled first (ADC0.CTRLA.ENABLE = 1) before DMA sequencing is enabled (ADC1.DSEQCTRL != 0).

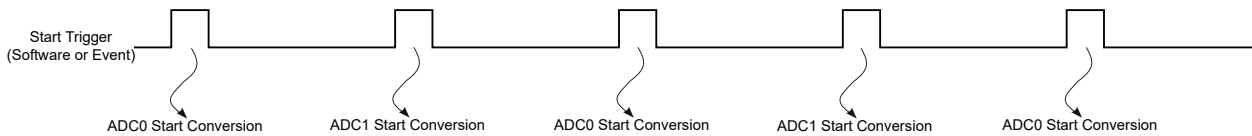
ADC measurements can either start simultaneously on both ADCs, or be interleaved. The trigger mode selection is available in the Host ADC Control A register (ADC0.CTRLA.DUALSEL).

**Note:** The interleaved sampling is only usable in single conversion mode (ADC.CTRLB.FREERUN = 0).

To restart an interleaved sequence, the user can apply different options:

- Flush the Host ADC (ADC0.SWTRIG.FLUSH = 1)
- Disable/re-enable the Host ADC (ADC0.CTRLA.ENABLE)

- Reset and reconfigure Host ADC (ADC0.CTRLA.SWRST = 1)
- Enable the flush event (EVCTRL.FLUSHEI = 1)



#### 51.6.4 DMA Operation

The ADC generates the following DMA request:

- Result Conversion Ready (RESRDY): the request is set when a conversion result is available and cleared when the RESULT register is read. When the averaging operation is enabled, the DMA request is set when the averaging is completed and result is available.
- DMA Sequencing (DSEQ): See [DMA Sequencing](#) for details

#### 51.6.5 Interrupts

The ADC has the following interrupt sources:

- Result Conversion Ready: RESRDY
- Window Monitor: WINMON
- Overrun: OVERRUN

These interrupts, except the OVERRUN interrupt, are asynchronous wake-up sources. See [Sleep Mode Controller](#) for details.

Each interrupt source has an interrupt flag associated with it. The interrupt flag in the Interrupt Flag Status and Clear (INTFLAG) register is set when the interrupt condition occurs. Each interrupt can be individually enabled by writing a one to the corresponding bit in the Interrupt Enable Set (INTENSET) register, and disabled by writing a one to the corresponding bit in the Interrupt Enable Clear (INTENCLR) register. The status of enabled interrupts can be read from either INTENSET or INTENCLR.

An interrupt request is generated when the interrupt flag is set and the corresponding interrupt is enabled. The interrupt request remains active until the interrupt flag is cleared, the interrupt is disabled, or the ADC is reset. See INTFLAG register for details on how to clear interrupt flags. All interrupt requests from the peripheral are ORed together on system level to generate one combined interrupt request to the NVIC. Refer to [Nested Vector Interrupt Controller](#) for details. The user must read the INTFLAG register to determine which interrupt condition is present.

Note that interrupts must be globally enabled for interrupt requests to be generated. Refer to [Nested Vector Interrupt Controller](#) for details.

#### 51.6.6 Events

The ADC can generate the following output events:

- Result Ready (RESRDY): Generated when the conversion is complete and the result is available. Refer to EVCTRL register for details.
- Window Monitor (WINMON): Generated when the window monitor condition match. Refer to CTRLB register for details.

Setting an Event Output bit in the Event Control Register (EVCTRL.xxEO=1) enables the corresponding output event. Clearing this bit disables the corresponding output event. Refer to the [Event System](#) chapter for details on configuring the event system.

The ADC can take the following actions on an input event:

- Start conversion (START): Start a conversion. Refer to SWTRIG register for details.

- Conversion flush (FLUSH): Flush the conversion. Refer to SWTRIG register for details.

Setting an Event Input bit in the Event Control register (EVCTRL.xxEI=1) enables the corresponding action on input event. Clearing this bit disables the corresponding action on input event.

The ADC uses only asynchronous events, so the asynchronous Event System channel path must be configured. By default, the ADC will detect a rising edge on the incoming event. If the ADC action must be performed on the falling edge of the incoming event, the event line must be inverted first. This is done by setting the corresponding Event Invert Enable bit in Event Control register (EVCTRL.xINV=1).

**Note:** If several events are connected to the ADC, the enabled action will be taken on any of the incoming events. If FLUSH and START events are available at the same time, the FLUSH event has priority.

### 51.6.7 Sleep Mode Operation

The ONDEMAND and RUNSTDBY bits in the Control A register (CTRLA) control the behavior of the ADC during standby sleep mode, in cases where the ADC is enabled (CTRLA.ENABLE = 1). For further details on available options, refer to the following table.

**Note:** When CTRLA.ONDEMAND=1, the analog block is powered-off when the conversion is complete. When a start request is detected, the system returns from sleep and starts a new conversion after the start-up time delay.

**Table 51-5.** ADC Sleep Behavior

CTRLA.RUNSTDBY	CTRLA.ONDEMAND	CTRLA.ENABLE	Description
x	x	0	Disabled
0	0	1	Run in all sleep modes except STANDBY.
0	1	1	Run in all sleep modes on request, except STANDBY.
1	0	1	Run in all sleep modes.
1	1	1	Run in all sleep modes on request.

### 51.6.8 Synchronization

Due to asynchronicity between the main clock domain and the peripheral clock domains, some registers need to be synchronized when written or read.

The following bits are synchronized when written:

- Software Reset bit in Control A register (CTRLA.SWRST)
- Enable bit in Control A register (CTRLA.ENABLE)

The following registers are synchronized when written:

- Input Control register (INPUTCTRL)
- Control B register (CTRLB)
- Reference Control (REFCTRL)
- Average control register (AVGCTRL)
- Sampling time control register (SAMPCTRL)
- Window Monitor Lower Threshold register (WINLT)
- Window Monitor Upper Threshold register (WINUT)
- Gain correction register (GAINCORR)
- Offset Correction register (OFFSETCORR)
- Software Trigger register (SWTRIG)



Required write synchronization is denoted by the "Write-Synchronized" property in the register description.

## 51.7 Register Summary

Offset	Name	Bit Pos.	7	6	5	4	3	2	1	0	
0x00	CTRLA	7:0	ONDEMAND	RUNSTDBY	SLAVEEN	DUALSEL[1:0]			ENABLE	SWRST	
		15:8	R2R						PRESCALER[2:0]		
0x02	EVCTRL	7:0			WINMONEO	RESRDYEO	STARTINV	FLUSHINV	STARTEI	FLUSHEI	
0x03	DBGCTRL	7:0								DBGRUN	
0x04	INPUTCTRL	7:0	DIFFMODE					MUXPOS[4:0]			
		15:8	DSEQSTOP					MUXNEG[4:0]			
0x06	CTRLB	7:0					RESSEL[1:0]	CORREN	FREERUN	LEFTADJ	
		15:8					WINSS	WINMODE[2:0]			
0x08	REFCTRL	7:0	REFCOMP					REFSEL[3:0]			
0x09	Reserved										
0x0A	AVGCTRL	7:0		ADJRES[2:0]				SAMPLENUM[3:0]			
0x0B	SAMPCTRL	7:0	OFFCOMP					SAMPLEN[5:0]			
0x0C	WINLT	7:0					WINLT[7:0]				
		15:8					WINLT[15:8]				
0x0E	WINUT	7:0					WINUT[7:0]				
		15:8					WINUT[15:8]				
0x10	GAINCORR	7:0					GAINCORR[7:0]				
		15:8					GAINCORR[11:8]				
0x12	OFFSETCORR	7:0				OFFSETCORR[7:0]					
		15:8					OFFSETCORR[11:8]				
0x14	SWTRIG	7:0						START	FLUSH		
0x15	Reserved										
...											
0x2B											
0x2C	INTENCLR	7:0						WINMON	OVERRUN	RESRDY	
0x2D	INTENSET	7:0						WINMON	OVERRUN	RESRDY	
0x2E	INTFLAG	7:0						WINMON	OVERRUN	RESRDY	
0x2F	STATUS	7:0	WCC[5:0]								ADCBUSY
0x30	SYNCBUSY	7:0	WINLT	SAMPCTRL	AVGCTRL	REFCTRL	CTRLB	INPUTCTRL	ENABLE	SWRST	
		15:8					SWTRIG	OFFSETCORR	GAINCORR	WINUT	
		23:16									
		31:24									
0x34	DSEQDATA	7:0	DATA[7:0]								
		15:8	DATA[15:8]								
		23:16	DATA[23:16]								
		31:24	DATA[31:24]								
0x38	DSEQCTRL	7:0	GAINCORR	WINUT	WINLT	SAMPCTRL	AVGCTRL	REFCTRL	CTRLB	INPUTCTRL	
		15:8								OFFSETCORR	
		23:16									
		31:24	AUTOSTART								
0x3C	DSEQSTAT	7:0	GAINCORR	WINUT	WINLT	SAMPCTRL	AVGCTRL	REFCTRL	CTRLB	INPUTCTRL	
		15:8								OFFSETCORR	
		23:16									
		31:24	BUSY								
0x40	RESULT	7:0	RESULT[7:0]								
		15:8	RESULT[15:8]								
0x42	Reserved										
0x43											
0x44	RESS	7:0	RESS[7:0]								
		15:8	RESS[15:8]								
0x46	Reserved										
0x47											
0x48	CALIB	7:0		BIASR2R[2:0]				BIASCOMP[2:0]			
		15:8						BIASREFBUF[2:0]			

### 51.7.1 Control A

**Name:** CTRLA  
**Offset:** 0x00  
**Reset:** 0x0000  
**Property:** PAC Write-Protection, Enable-Protected Bits, Write-Synchronized Bits

Bit	15	14	13	12	11	10	9	8
	R2R					PRESCALER[2:0]		
Access	R/W					R/W	R/W	R/W
Reset	0					0	0	0
Bit	7	6	5	4	3	2	1	0
	ONDEMAND	RUNSTDBY	SLAVEEN	DUALSEL[1:0]			ENABLE	SWRST
Access	R/W	R/W	R/W	R/W	R/W		R/W	R/W
Reset	0	0	0	0	0		0	0

#### Bit 15 – R2R Rail to Rail Operation Enable

Value	Description
0	Rail-to-Rail operation disable
1	Rail-to-Rail operation enable. The R2R bit must be set to '1' only in differential mode.

#### Bits 10:8 – PRESCALER[2:0] Prescaler Configuration

This field defines the ADC clock relative to the peripheral clock as provided in the table below. This field is not synchronized. For the Client ADC, these bits have no effect when the SLAVEEN bit is set (CTRLA.SLAVEEN = 1).

**Note:** ADC DMA Sequencing operations are limited to DIV2, DIV4 and DIV8 prescalers configuration.

Value	Name	Description
0x0	DIV2	Peripheral clock divided by 2
0x1	DIV4	Peripheral clock divided by 4
0x2	DIV8	Peripheral clock divided by 8
0x3	DIV16	Peripheral clock divided by 16
0x4	DIV32	Peripheral clock divided by 32
0x5	DIV64	Peripheral clock divided by 64
0x6	DIV128	Peripheral clock divided by 128
0x7	DIV256	Peripheral clock divided by 256

#### Bit 7 – ONDEMAND On Demand Control

The On Demand operation mode allows the ADC to be enabled or disabled, depending on other peripheral requests.

In On Demand operation mode, that is, if the ONDEMAND bit has been previously set, the ADC will only be running when requested by a peripheral. If there is no peripheral requesting the ADC will be in a disable state.

If On Demand is disabled the ADC will always be running when enabled.

In Standby Sleep mode, the On Demand operation is still active if the CTRLA.RUNSTDBY bit is '1'. If CTRLA.RUNSTDBY is '0', the ADC is disabled.

This bit is not synchronized.

**Note:** For the Client ADC, this bit has no effect when the SLAVEEN bit is set (CTRLA.SLAVEEN = 1). ONDEMAND bit from Host ADC instance will control the On Demand operation mode.

Value	Description
0	The ADC is always on , if enabled.
1	The ADC is enabled, when a peripheral is requesting the ADC conversion. The ADC is disabled if no peripheral is requesting it.

### Bit 6 – RUNSTDBY Run in Standby

This bit controls how the ADC behaves during Standby Sleep mode. This bit is not synchronized.

**Note:** For the Client ADC, this bit has no effect when the SLAVEEN bit is set (CTRLA.SLAVEEN = 1). The RUNSTDBY bit from Host ADC instance will control the Client ADC operation in Standby Sleep mode.

Value	Description
0	The ADC is halted during Standby Sleep mode.
1	The ADC is not stopped in Standby Sleep mode. If CTRLA.ONDEMAND = 1, the ADC will be running when a peripheral is requesting it. If CTRLA.ONDEMAND = 0, the ADC will always be running in Standby Sleep mode.

### Bit 5 – SLAVEEN Client Enable

This bit enables the Host or Client operation, and it is available only in the Client ADC instance. This bit is not synchronized and can be set only for the Client ADC. For the Host ADC, this bit is always read zero.

Value	Description
0	The Host/Client operation is disabled
1	The ADC1 is enabled as a Client of ADC0

### Bits 4:3 – DUALSEL[1:0] Dual Mode Trigger Selection

These bits define the trigger mode, as shown in Table below. These bits are available in the Host ADC and have no effect if the Host/Client operation is disabled (ADC1.CTRLA.SLAVEEN = 0).

Value	Name	Description
0x0	BOTH	Start event or software trigger will start a conversion on both ADCs
0x1	INTERLEAVE	START event or software trigger will alternately start a conversion on ADC0 and ADC1. <b>Note:</b> The interleaved sampling is only usable in single conversion mode (ADC.CTRLB.FREERUN = 0).
0x2 – 0x3		Reserved

### Bit 1 – ENABLE Enable

Due to synchronization there is delay from writing CTRLA.ENABLE until the peripheral is enabled/disabled. The value written to CTRLA.ENABLE will read back immediately and the ENABLE bit in the Synchronization Busy register (SYNCBUSY.ENABLE) will be set. The SYNCBUSY.ENABLE register will be cleared when the operation is complete.

For the Client ADC, this bit has no effect when the SLAVEEN bit is set (CTRLA.SLAVEEN = 1).

Value	Description
0	The ADC is disabled.
1	The ADC is enabled.

### Bit 0 – SWRST Software Reset

Writing a '0' to this bit has no effect.

Writing a '1' to this bit resets all registers in the ADC, except DBGCTRL, to their initial state, and the ADC will be disabled.

Writing a '1' to CTRLA.SWRST will always take precedence, meaning that all other writes in the same write-operation will be discarded.

Due to synchronization there is a delay from writing CTRLA.SWRST until the reset is complete. CTRLA.SWRST and SYNCBUSY.SWRST will both be cleared when the reset is complete.

#### Notes:

1. When the CTRLA.SWRST is written, the user must poll the SYNCBUSY.SWRST bit to know when the reset operation is complete.
2. During a SWRST, access to registers/bits without the SWRST are disallowed until the SYNCBUSY.SWRST is cleared by hardware.

Value	Description
0	There is no reset operation ongoing.
1	The reset operation is ongoing.

## 51.7.2 Event Control

**Name:** EVCTRL  
**Offset:** 0x02  
**Reset:** 0x00  
**Property:** PAC Write-Protection

Bit	7	6	5	4	3	2	1	0
Access			R/W	R/W	R/W	R/W	R/W	R/W
Reset			0	0	0	0	0	0

### Bit 5 – WINMONEO Window Monitor Event Out

This bit indicates whether the Window Monitor event output is enabled or not and an output event will be generated when the window monitor detects something.

Value	Description
0	Window Monitor event output is disabled and an event will not be generated.
1	Window Monitor event output is enabled and an event will be generated.

### Bit 4 – RESRDYEO Result Ready Event Out

This bit indicates whether the Result Ready event output is enabled or not and an output event will be generated when the conversion result is available.

Value	Description
0	Result Ready event output is disabled and an event will not be generated.
1	Result Ready event output is enabled and an event will be generated.

### Bit 3 – STARTINV Start Conversion Event Invert Enable

For the Client ADC, this bit has no effect when the SLAVEEN bit is set (CTRLA.SLAVEEN= 1).

Value	Description
0	Start event input source is not inverted.
1	Start event input source is inverted.

### Bit 2 – FLUSHINV Flush Event Invert Enable

For the Client ADC, this bit has no effect when the SLAVEEN bit is set (CTRLA.SLAVEEN= 1).

Value	Description
0	Flush event input source is not inverted.
1	Flush event input source is inverted.

### Bit 1 – STARTEI Start Conversion Event Input Enable

For the Client ADC, this bit has no effect when the SLAVEEN bit is set (CTRLA.SLAVEEN= 1).

Value	Description
0	A new conversion will not be triggered on any incoming event.
1	A new conversion will be triggered on any incoming event.

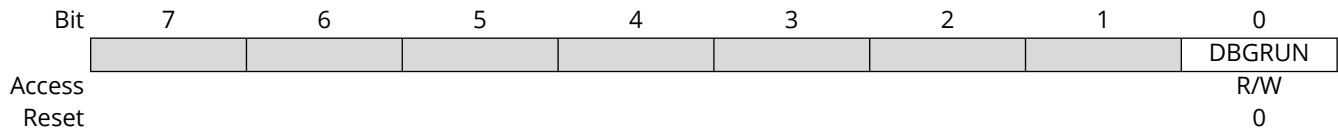
### Bit 0 – FLUSHEI Flush Event Input Enable

For a Client ADC, this bit has no effect when the respective SLAVEEN bit is set (CTRLA.SLAVEEN= 1).

Value	Description
0	A flush and new conversion will not be triggered on any incoming event.
1	A flush and new conversion will be triggered on any incoming event.

### 51.7.3 Debug Control

**Name:** DBGCTRL  
**Offset:** 0x03  
**Reset:** 0x00  
**Property:** PAC Write-Protection



#### Bit 0 – DBGRUN Debug Run

This bit is not reset by a software reset.

This bit controls the functionality when the CPU is halted by an external debugger.

This bit should be written only while a conversion is not ongoing.

When Client operation is enabled, Host and Client ADC instances must have the same DBGRUN bit value to ensure proper operation.

Value	Description
0	The ADC is halted when the CPU is halted by an external debugger.
1	The ADC continues normal operation when the CPU is halted by an external debugger.

## 51.7.4 Input Control

**Name:** INPUTCTRL  
**Offset:** 0x04  
**Reset:** 0x0000  
**Property:** PAC Write-Protection, Write-Synchronized

**Note:** This register is write-synchronized: SYNCBUSY.INPUTCTRL must be checked to ensure the INPUTCTRL register synchronization is complete.

Bit	15	14	13	12	11	10	9	8
	DSEQSTOP			MUXNEG[4:0]				
Access	R/W			R/W	R/W	R/W	R/W	R/W
Reset	0			0	0	0	0	0
Bit	7	6	5	4	3	2	1	0
	DIFFMODE			MUXPOS[4:0]				
Access	R/W			R/W	R/W	R/W	R/W	R/W
Reset	0			0	0	0	0	0

### Bit 15 – DSEQSTOP Stop DMA Sequencing

When the bit is set, the DMA sequencing automatically stops when the last sequence configuration is complete.

**Note:** one more conversion will be done after the last sequence is complete.

### Bits 12:8 – MUXNEG[4:0] Negative MUX Input Selection

These bits define the MUX selection for the negative ADC input.

Value	Name	Description
0x00	AIN0	ADC AIN0 pin
0x01	AIN1	ADC AIN1 pin
0x02	AIN2	ADC AIN2 pin
0x03	AIN3	ADC AIN3 pin
0x04	AIN4	ADC AIN4 pin
0x05	AIN5	ADC AIN5 pin
0x06	AIN6	ADC AIN6 pin
0x07	AIN7	ADC AIN7 pin
0x08 – 0x17	-	Reserved
0x18	AVSS	Internal ground
0x19 – 0x1F	-	Reserved

### Bit 7 – DIFFMODE Differential Mode

Value	Description
0x0	The ADC is running in singled-ended mode.
0x1	The ADC is running in differential mode. In this mode, the voltage difference between the MUXPOS and MUXNEG inputs will be converted by the ADC.

### Bits 4:0 – MUXPOS[4:0] Positive MUX Input Selection

These bits define the MUX selection for the positive ADC input. If the internal bandgap voltage input channel is selected, then the Sampling Time Length bit group in the Sampling Control register must be written with a corresponding value, as shown in “Table 54-24. Operating Conditions”.

Value	Name	Description
0x00	AIN0	ADC AIN0 pin
0x01	AIN1	ADC AIN1 pin
0x02	AIN2	ADC AIN2 pin

Value	Name	Description
0x03	AIN3	ADC AIN3 pin
0x04	AIN4	ADC AIN4 pin
0x05	AIN5	ADC AIN5 pin
0x06	AIN6	ADC AIN6 pin
0x07	AIN7	ADC AIN7 pin
0x08	AIN8	ADC AIN8 pin
0x09	AIN9	ADC AIN9 pin
0x0A	AIN10	ADC AIN10 pin
0x0B	AIN11	ADC AIN11 pin
0x0C	AIN12	ADC AIN12 pin
0x0D	AIN13	ADC AIN13 pin
0x0E	AIN14	ADC AIN14 pin
0x0F	AIN15	ADC AIN15 pin
0x10 - 0x17	-	Reserved
0x18	SCALEDVDDCORE	1/4 Scaled VDDCORE Supply
0x19	SCALEDVBAT	1/4 Scaled VBAT Supply
0x1A	SCALEDVDD	1/4 Scaled VDD Supply
0x1B	BANDGAP	Bandgap Voltage
0x1C-0x1D	-	Reserved
0x1E	DAC0	DAC0 Output



## 51.7.5 Control B

**Name:** CTRLB  
**Offset:** 0x06  
**Reset:** 0x0000  
**Property:** PAC Write-Protection, Write-Synchronized

**Note:** This register is write-synchronized: SYNCBUSY.CTRLB must be checked to ensure the CTRLB register synchronization is complete.

Bit	15	14	13	12	11	10	9	8
					WINSS	WINMODE[2:0]		
Access					R/W	R/W	R/W	R/W
Reset					0	0	0	0
Bit	7	6	5	4	3	2	1	0
				RESSEL[1:0]		CORREN	FREERUN	LEFTADJ
Access				R/W	R/W	R/W	R/W	R/W
Reset				0	0	0	0	0

### Bit 11 – WINSS Window Single Sample

When this bit is written the window functionality is working on each conversions and not on the accumulated value. The number of conversions matching with the window comparator is available on STATUS register (STATUS.WCC). The last sample result is available on RESS register.

### Bits 10:8 – WINMODE[2:0] Window Monitor Mode

These bits enable and define the window monitor mode.

Value	Name	Description
0x0	DISABLE	No window mode (default)
0x1	MODE1	RESULT > WINLT
0x2	MODE2	RESULT < WINUT
0x3	MODE3	WINLT < RESULT < WINUT
0x4	MODE4	!(WINLT < RESULT < WINUT)
0x5 – 0x7		Reserved

### Bits 4:3 – RESSEL[1:0] Conversion Result Resolution

These bits define whether the ADC completes the conversion 12-, 10- or 8-bit result resolution.

Value	Name	Description
0x0	12BIT	12-bit result
0x1	16BIT	For averaging mode output
0x2	10BIT	10-bit result
0x3	8BIT	8-bit result

### Bit 2 – CORREN Digital Correction Logic Enable

The ADC conversion result in the RESULT register is then corrected for gain and offset based on the values in the GAINCORR and OFFSETCORR registers. Conversion time will be increased by 13 cycles according to the value in the Offset Correction Value bit group in the Offset Correction register.

Value	Description
0	Disable the digital result correction
1	Enable the digital result correction

### Bit 1 – FREERUN Free Running Mode

Value	Description
0	The ADC run in single conversion mode
1	The ADC is in free running mode and a new conversion will be initiated when a previous conversion completes

**Bit 0 – LEFTADJ** Left-Adjusted Result

The high byte of the 12-bit result will be present in the upper part of the result register. Writing this bit to zero (default) will right-adjust the value in the RESULT register.

Value	Description
0	The ADC conversion result is right-adjusted in the RESULT register
1	The ADC conversion result is left-adjusted in the RESULT register

## 51.7.6 Reference Control

**Name:** REFCTRL  
**Offset:** 0x08  
**Reset:** 0x00  
**Property:** PAC Write-Protection, Write-Synchronized

**Note:** This register is write-synchronized: SYNCBUSY.REFCTRL must be checked to ensure the REFCTRL register synchronization is complete.

Bit	7	6	5	4	3	2	1	0
	REFCOMP				REFSEL[3:0]			
Access	R/W				R/W	R/W	R/W	R/W
Reset	0				0	0	0	0

### Bit 7 – REFCOMP Reference Buffer Offset Compensation Enable

The gain error can be reduced by enabling the reference buffer offset compensation. This will increase the start-up time of the reference.

**Note:** If the reference buffer offset compensation is enabled (REFCOMP = 1) and the ADC reference selection is not using VDDANA (REFSEL != INTVCC1), the first 5 conversions of the ADC must be discarded after the ADC is enabled.

Value	Description
0	Reference buffer offset compensation is disabled.
1	Reference buffer offset compensation is enabled.

### Bits 3:0 – REFSEL[3:0] Reference Selection

These bits select the reference for the ADC.

**Note:** If the internal bandgap voltage reference is selected (REFCTRL.REFSEL = 0x0), the On Demand operation mode (CTRLA.ONDEMAND = 0) is not supported and a delay of minimum 40  $\mu$ s must be respected between the enable of the ADC (CTRLA.ENABLE) and the start of the first conversion. In case an ADC conversion is triggered by an input event, the delay must be introduced between the enable of the ADC and the enable of the ADC EVSYS channel.

Value	Name	Description
0x0	INTREF	internal bandgap reference, refer to the VREF.SEL bit-field in <a href="#">SUPC-Supply Controller</a> for more details
0x01		Reserved
0x2	INTVCC0	1/2 AVDD (only for AVDD > 2.0V)
0x3	INTVCC1	AVDD
0x4	AREFA	External reference
0x5	AREFB	External reference
0x6	AREFC	External reference (ADC1 only)
other	-	Reserved

### 51.7.7 Average Control

**Name:** AVGCTRL  
**Offset:** 0x0A  
**Reset:** 0x00  
**Property:** PAC Write-Protection, Write-Synchronized

**Note:** This register is write-synchronized: SYNCBUSY.AVGCTRL must be checked to ensure the AVGCTRL register synchronization is complete.

Bit	7	6	5	4	3	2	1	0
		ADJRES[2:0]			SAMPLENUM[3:0]			
Access		R/W	R/W	R/W	R/W	R/W	R/W	R/W
Reset		0	0	0	0	0	0	0

**Bits 6:4 – ADJRES[2:0]** Adjusting Result / Division Coefficient  
 These bits define the division coefficient in  $2^n$  steps.

**Bits 3:0 – SAMPLENUM[3:0]** Number of Samples to be Collected  
 These bits define how many samples are added together. The result will be available in the Result register (RESULT). Note: if the result width increases, CTRLB.RESSEL must be changed.

Value	Description
0x0	1 sample
0x1	2 samples
0x2	4 samples
0x3	8 samples
0x4	16 samples
0x5	32 samples
0x6	64 samples
0x7	128 samples
0x8	256 samples
0x9	512 samples
0xA	1024 samples
0xB – 0xF	Reserved

### 51.7.8 Sampling Time Control

**Name:** SAMPCTRL  
**Offset:** 0x0B  
**Reset:** 0x00  
**Property:** PAC Write-Protection, Write-Synchronized

**Note:** This register is write-synchronized: SYNCBUSY.SAMPCTRL must be checked to ensure the SAMPCTRL register synchronization is complete.

Bit	7	6	5	4	3	2	1	0
	OFFCOMP		SAMPLEN[5:0]					
Access	R/W		R/W	R/W	R/W	R/W	R/W	R/W
Reset	0		0	0	0	0	0	0

#### Bit 7 – OFFCOMP Comparator Offset Compensation Enable

Setting this bit enables the offset compensation for each sampling period to ensure low offset and immunity to temperature or voltage drift. ADC sampling time is fixed to 4 ADC Clock cycles when OFFCOMP = 1.

#### Bits 5:0 – SAMPLEN[5:0] Sampling Time Length

These bits control the ADC sample time ( $T_{SAMP}$ ) in number of ADC Clock Period (CLK\_ADC aka TAD), depending on the prescaler value, thus controlling the ADC input impedance. Sampling time is set according to the equation:

$$T_{SAMP} = (SAMPLEN + 1) \cdot (TAD)$$

SAMPLEN is only available when OFFCOMP = 0.

**Note:** Refer to ADC Electrical Characteristics for  $T_{SAMP}$  computation.

### 51.7.9 Window Monitor Lower Threshold

**Name:** WINLT  
**Offset:** 0x0C  
**Reset:** 0x0000  
**Property:** PAC Write-Protection, Write-Synchronized

**Note:** This register is write-synchronized: SYNCBUSY.WINLT must be checked to ensure the WINLT register synchronization is complete.

Bit	15	14	13	12	11	10	9	8
	WINLT[15:8]							
Access	R/W	R/W	R/W	R/W	R/W	R/W	R/W	R/W
Reset	0	0	0	0	0	0	0	0
Bit	7	6	5	4	3	2	1	0
	WINLT[7:0]							
Access	R/W	R/W	R/W	R/W	R/W	R/W	R/W	R/W
Reset	0	0	0	0	0	0	0	0

#### Bits 15:0 – WINLT[15:0] Window Lower Threshold

If the window monitor is enabled, these bits define the lower threshold value.

### 51.7.10 Window Monitor Upper Threshold

**Name:** WINUT  
**Offset:** 0x0E  
**Reset:** 0x0000  
**Property:** PAC Write-Protection, Write-Synchronized

**Note:** This register is write-synchronized: SYNCBUSY.WINUT must be checked to ensure the WINUT register synchronization is complete.

Bit	15	14	13	12	11	10	9	8
	WINUT[15:8]							
Access	R/W	R/W	R/W	R/W	R/W	R/W	R/W	R/W
Reset	0	0	0	0	0	0	0	0
Bit	7	6	5	4	3	2	1	0
	WINUT[7:0]							
Access	R/W	R/W	R/W	R/W	R/W	R/W	R/W	R/W
Reset	0	0	0	0	0	0	0	0

#### Bits 15:0 – WINUT[15:0] Window Upper Threshold

If the window monitor is enabled, these bits define the upper threshold value.

### 51.7.11 Gain Correction

**Name:** GAINCORR  
**Offset:** 0x10  
**Reset:** 0x0000  
**Property:** PAC Write-Protection, Write-Synchronized

**Note:** This register is write-synchronized: SYNCBUSY.GAINCORR must be checked to ensure the GAINCORR register synchronization is complete.

Bit	15	14	13	12	11	10	9	8
	GAINCORR[11:8]							
Access					R/W	R/W	R/W	R/W
Reset					0	0	0	0
Bit	7	6	5	4	3	2	1	0
	GAINCORR[7:0]							
Access	R/W	R/W	R/W	R/W	R/W	R/W	R/W	R/W
Reset	0	0	0	0	0	0	0	0

#### Bits 11:0 – GAINCORR[11:0] Gain Correction Value

If CTRLB.CORREN=1, these bits define how the ADC conversion result is compensated for gain error before being written to the result register. The gain correction is a fractional value, a 1-bit integer plus an 11-bit fraction, and therefore  $\frac{1}{2} \leq \text{GAINCORR} < 2$ . GAINCORR values range from 0.1000000000 to 1.1111111111.



### 51.7.12 Offset Correction

**Name:** OFFSETCORR  
**Offset:** 0x12  
**Reset:** 0x0000  
**Property:** PAC Write-Protection, Write-Synchronized

**Note:** This register is write-synchronized: SYNCBUSY.OFFSETCORR must be checked to ensure the OFFSETCORR register synchronization is complete.

Bit	15	14	13	12	11	10	9	8
	OFFSETCORR[11:8]							
Access					R/W	R/W	R/W	R/W
Reset					0	0	0	0
Bit	7	6	5	4	3	2	1	0
	OFFSETCORR[7:0]							
Access	R/W	R/W	R/W	R/W	R/W	R/W	R/W	R/W
Reset	0	0	0	0	0	0	0	0

#### Bits 11:0 – OFFSETCORR[11:0] Offset Correction Value

If CTRLB.CORREN=1, these bits define how the ADC conversion result is compensated for offset error before being written to the Result register. This OFFSETCORR value is in two's complement format.

### 51.7.13 Software Trigger

**Name:** SWTRIG  
**Offset:** 0x14  
**Reset:** 0x00  
**Property:** PAC Write-Protection, Write-Synchronized

**Note:** This register is write-synchronized: SYNCBUSY.SWTRIG must be checked to ensure the SWTRIG register synchronization is complete.

Bit	7	6	5	4	3	2	1	0
							START	FLUSH
Access							W	RW
Reset							0	0

#### Bit 1 – START Start ADC Conversion

Writing a '1' to this bit will start a conversion or sequence. The bit is cleared by hardware when the conversion has started. Writing a '1' to this bit when it is already set has no effect. Writing a '0' to this bit has no effect.

#### Bit 0 – FLUSH ADC Conversion Flush

Writing a '1' to this bit will flush the ADC pipeline. A flush will restart the ADC clock on the next peripheral clock edge, and all conversions in progress will be aborted and lost. This bit will be cleared after the ADC has been flushed. After the flush, the ADC will resume where it left off; i.e., if a conversion was pending, the ADC will start a new conversion. Writing a '0' to this bit has no effect.

### 51.7.14 Interrupt Enable Clear

**Name:** INTENCLR  
**Offset:** 0x2C  
**Reset:** 0x00  
**Property:** PAC Write-Protection

This register allows the user to disable an interrupt without doing a read-modify-write operation. Changes in this register will also be reflected in the Interrupt Enable Set (INTENSET) register.

Bit	7	6	5	4	3	2	1	0
						WINMON	OVERRUN	RESRDY
Access						R/W	R/W	R/W
Reset						0	0	0

#### Bit 2 – WINMON Window Monitor Interrupt Disable

Writing a '0' to this bit has no effect.  
 Writing a '1' to this bit will clear the Window Monitor Interrupt Enable bit, which disables the corresponding interrupt request.

Value	Description
0	The window monitor interrupt is disabled.
1	The window monitor interrupt is enabled, and an interrupt request will be generated when the Window Monitor interrupt flag is set.

#### Bit 1 – OVERRUN Overrun Interrupt Disable

Writing a '0' to this bit has no effect.  
 Writing a '1' to this bit will clear the Overrun Interrupt Enable bit, which disables the corresponding interrupt request.

Value	Description
0	The Overrun interrupt is disabled.
1	The Overrun interrupt is enabled, and an interrupt request will be generated when the Overrun interrupt flag is set.

#### Bit 0 – RESRDY Result Ready Interrupt Disable

Writing a '0' to this bit has no effect.  
 Writing a '1' to this bit will clear the Result Ready Interrupt Enable bit, which disables the corresponding interrupt request.

Value	Description
0	The Result Ready interrupt is disabled.
1	The Result Ready interrupt is enabled, and an interrupt request will be generated when the Result Ready interrupt flag is set.

### 51.7.15 Interrupt Enable Set

**Name:** INTENSET  
**Offset:** 0x2D  
**Reset:** 0x00  
**Property:** PAC Write-Protection

This register allows the user to enable an interrupt without doing a read-modify-write operation. Changes in this register will also be reflected in the Interrupt Enable Clear (INTENCLR) register.

Bit	7	6	5	4	3	2	1	0
						WINMON	OVERRUN	RESRDY
Access						R/W	R/W	R/W
Reset						0	0	0

#### Bit 2 – WINMON Window Monitor Interrupt Enable

Writing a '0' to this bit has no effect.

Writing a '1' to this bit will set the Window Monitor Interrupt bit, which enables the Window Monitor interrupt.

Value	Description
0	The Window Monitor interrupt is disabled.
1	The Window Monitor interrupt is enabled.

#### Bit 1 – OVERRUN Overrun Interrupt Enable

Writing a '0' to this bit has no effect.

Writing a '1' to this bit will set the Overrun Interrupt bit, which enables the Overrun interrupt.

Value	Description
0	The Overrun interrupt is disabled.
1	The Overrun interrupt is enabled.

#### Bit 0 – RESRDY Result Ready Interrupt Enable

Writing a '0' to this bit has no effect.

Writing a '1' to this bit will set the Result Ready Interrupt bit, which enables the Result Ready interrupt.

Value	Description
0	The Result Ready interrupt is disabled.
1	The Result Ready interrupt is enabled.

### 51.7.16 Interrupt Flag Status and Clear

**Name:** INTFLAG  
**Offset:** 0x2E  
**Reset:** 0x00  
**Property:** -

Bit	7	6	5	4	3	2	1	0
						WINMON	OVERRUN	RESRDY
Access						R/W	R/W	R/W
Reset						0	0	0

#### Bit 2 – WINMON Window Monitor Interrupt Flag

This flag is cleared by writing a '1' to the flag or by reading the RESULT register.

This flag is set on the next GCLK\_ADC cycle after a match with the window monitor condition, and an interrupt request will be generated if INTENCLR/SET.WINMON is '1'.

Writing a '0' to this bit has no effect.

Writing a '1' to this bit clears the Window Monitor interrupt flag.

#### Bit 1 – OVERRUN Overrun Interrupt Flag

This flag is cleared by writing a '1' to the flag.

This flag is set if RESULT is written before the previous value has been read by CPU, and an interrupt request will be generated if INTENCLR/SET.OVERRUN=1.

Writing a '0' to this bit has no effect.

Writing a '1' to this bit clears the Overrun interrupt flag.

#### Bit 0 – RESRDY Result Ready Interrupt Flag

This flag is cleared by writing a '1' to the flag or by reading the RESULT register.

This flag is set when the conversion result is available, and an interrupt will be generated if INTENCLR/SET.RESRDY=1.

Writing a '0' to this bit has no effect.

Writing a '1' to this bit clears the Result Ready interrupt flag.

### 51.7.17 STATUS

**Name:** STATUS  
**Offset:** 0x2F  
**Reset:** 0x00  
**Property:** -

Bit	7	6	5	4	3	2	1	0
	WCC[5:0]							ADCBUSY
Access	R	R	R	R	R	R		R
Reset	0	0	0	0	0	0		0

#### Bits 7:2 – WCC[5:0] Window Comparator Counter

These bits indicates the number of sample matching with the window comparator.  
 Writing a zero to this bit will have no effect.  
 Writing a one to this bit will have no effect.

#### Bit 0 – ADCBUSY ADC Busy Status

This bit is read one when the data acquisition in on going.  
 Writing a zero to this bit will have no effect.  
 Writing a one to this bit will have no effect.

### 51.7.18 Synchronization Busy

**Name:** SYNCBUSY  
**Offset:** 0x30  
**Reset:** 0x00000000  
**Property:** -

Bit	31	30	29	28	27	26	25	24
Access								
Reset								
Bit	23	22	21	20	19	18	17	16
Access								
Reset								
Bit	15	14	13	12	11	10	9	8
Access					SWTRIG	OFFSETCORR	GAINCORR	WINUT
Reset					R	R	R	R
					0	0	0	0
Bit	7	6	5	4	3	2	1	0
Access	WINLT	SAMPCTRL	AVGCTRL	REFCTRL	CTRLB	INPUTCTRL	ENABLE	SWRST
Reset	R	R	R	R	R	R	R	R
	0	0	0	0	0	0	0	0

#### Bit 11 – SWTRIG Software Trigger Synchronization Busy

This bit is cleared when the synchronization of SWTRIG register between the clock domains is complete.

This bit is set when the synchronization of SWTRIG register between clock domains is started.

##### Notes:

1. For the Client ADC, this bit is always read zero when the SLAVEEN bit is set (CTRLA.SLAVEEN= 1).
2. SYNCBUSY.SWTRIG is set to 1 when waking up from Standby Sleep mode and must be ignored.

#### Bit 10 – OFFSETCORR Offset Correction Synchronization Busy

This bit is cleared when the synchronization of OFFSETCORR register between the clock domains is complete.

This bit is set when the synchronization of OFFSETCORR register between clock domains is started.

#### Bit 9 – GAINCORR Gain Correction Synchronization Busy

This bit is cleared when the synchronization of GAINCORR register between the clock domains is complete.

This bit is set when the synchronization of GAINCORR register between clock domains is started.

#### Bit 8 – WINUT Window Monitor Upper Threshold Synchronization Busy

This bit is cleared when the synchronization of WINUT register between the clock domains is complete.

This bit is set when the synchronization of WINUT register between clock domains is started.

#### Bit 7 – WINLT Window Monitor Lower Threshold Synchronization Busy

This bit is cleared when the synchronization of WINLT register between the clock domains is complete.

This bit is set when the synchronization of WINLT register between clock domains is started.

**Bit 6 – SAMPCTRL** Sampling Time Control Synchronization Busy

This bit is cleared when the synchronization of SAMPCTRL register between the clock domains is complete.

This bit is set when the synchronization of SAMPCTRL register between clock domains is started.

**Bit 5 – AVGCTRL** Average Control Synchronization Busy

This bit is cleared when the synchronization of AVGCTRL register between the clock domains is complete.

This bit is set when the synchronization of AVGCTRL register between clock domains is started.

**Bit 4 – REFCTRL** Reference Control Synchronization Busy

This bit is cleared when the synchronization of REFCTRL register between the clock domains is complete.

This bit is set when the synchronization of REFCTRL register between clock domains is started.

**Bit 3 – CTRLB** Control B Synchronization Busy

This bit is cleared when the synchronization of CTRLB register between the clock domains is complete.

This bit is set when the synchronization of CTRLB register between clock domains is started.

**Bit 2 – INPUTCTRL** Input Control Synchronization Busy

This bit is cleared when the synchronization of INPUTCTRL register between the clock domains is complete.

This bit is set when the synchronization of INPUTCTRL register between clock domains is started.

**Bit 1 – ENABLE** ENABLE Synchronization Busy

This bit is cleared when the synchronization of ENABLE register between the clock domains is complete.

This bit is set when the synchronization of ENABLE register between clock domains is started.

**Note:** For the Client ADC, this bit is always read zero when the SLAVEEN bit is set (CTRLA.SLAVEEN=1).

**Bit 0 – SWRST** SWRST Synchronization Busy

This bit is cleared when the synchronization of SWRST register between the clock domains is complete.

This bit is set when the synchronization of SWRST register between clock domains is started



### 51.7.19 DSEQDATA

**Name:** DSEQDATA  
**Offset:** 0x34  
**Reset:** 0x00000000  
**Property:** PAC Write-Protection

Bit	31	30	29	28	27	26	25	24
	DATA[31:24]							
Access	W	W	W	W	W	W	W	W
Reset	0	0	0	0	0	0	0	0
Bit	23	22	21	20	19	18	17	16
	DATA[23:16]							
Access	W	W	W	W	W	W	W	W
Reset	0	0	0	0	0	0	0	0
Bit	15	14	13	12	11	10	9	8
	DATA[15:8]							
Access	W	W	W	W	W	W	W	W
Reset	0	0	0	0	0	0	0	0
Bit	7	6	5	4	3	2	1	0
	DATA[7:0]							
Access	W	W	W	W	W	W	W	W
Reset	0	0	0	0	0	0	0	0

#### Bits 31:0 – DATA[31:0] DMA Sequential Data

This register stores data written by the DMA and re-directed to the first enabled ADC registers in the DSEQSTAT register.

## 51.7.20 DSEQCTRL

**Name:** DSEQCTRL  
**Offset:** 0x38  
**Reset:** 0x00000000  
**Property:** PAC Write-Protection

Bit	31	30	29	28	27	26	25	24
	AUTOSTART							
Access	R/W							
Reset	0							
Bit	23	22	21	20	19	18	17	16
Access								
Reset								
Bit	15	14	13	12	11	10	9	8
								OFFSETCORR
Access								R/W
Reset								0
Bit	7	6	5	4	3	2	1	0
	GAINCORR	WINUT	WINLT	SAMPCTRL	AVGCTRL	REFCTRL	CTRLB	INPUTCTRL
Access	R/W	R/W	R/W	R/W	R/W	R/W	R/W	R/W
Reset	0	0	0	0	0	0	0	0

### Bit 31 – AUTOSTART ADC Auto-Start Conversion

Value	Description
0	ADC conversion starts when a DMA sequence is complete and a start software or event trigger is received.
1	ADC conversion automatically starts when a DMA sequence is complete. This setting is ignored if the conversion start by event is enabled (EVCTRL.STARTEI = 1).

### Bit 8 – OFFSETCORR Offset Correction

Value	Description
0	DMA update of the Offset Correction register is disabled.
1	DMA update of the Offset Correction register is enabled.

### Bit 7 – GAINCORR Gain Correction

Value	Description
0	DMA update of the Gain Correction register is disabled.
1	DMA update of the Gain Correction register is enabled.

### Bit 6 – WINUT Window Monitor Upper Threshold

Value	Description
0	DMA update of the Window Monitor Upper Threshold register is disabled.
1	DMA update of the Window Monitor Upper Threshold register is enabled.

### Bit 5 – WINLT Window Monitor Lower Threshold

Value	Description
0	DMA update of the Window Monitor Lower Threshold register is disabled.
1	DMA update of the Window Monitor Lower Threshold register is enabled.

### Bit 4 – SAMPCTRL Sampling Time Control

Value	Description
0	DMA update of the Sampling Time Control register is disabled.
1	DMA update of the Sampling Time Control register is enabled.

### Bit 3 – AVGCTRL Average Control

**Note:** AVGCTRL must be set to '1' if AVGCTRL.SAMPLENUM>1.

Value	Description
0	DMA update of the Average Control register is disabled.
1	DMA update of the Average Control register is enabled.

### Bit 2 – REFCTRL Reference Control

Value	Description
0	DMA update of the Reference Control register is disabled.
1	DMA update of the Reference Control register is enabled.

### Bit 1 – CTRLB Control B

Value	Description
0	DMA update of the Control B register is disabled.
1	DMA update of the Control B register is enabled.

### Bit 0 – INPUTCTRL Input Control

Value	Description
0	DMA update of the Input Control register is disabled.
1	DMA update of the Input Control register is enabled.

## 51.7.21 DSEQSTAT

**Name:** DSEQSTAT  
**Offset:** 0x3C  
**Reset:** 0x00000000  
**Property:** -

Bit	31	30	29	28	27	26	25	24
	BUSY							
Access	R							
Reset	0							
Bit	23	22	21	20	19	18	17	16
Access								
Reset								
Bit	15	14	13	12	11	10	9	8
								OFFSETCORR
Access								R
Reset								0
Bit	7	6	5	4	3	2	1	0
	GAINCORR	WINUT	WINLT	SAMPCTRL	AVGCTRL	REFCTRL	CTRLB	INPUTCTRL
Access	R	R	R	R	R	R	R	R
Reset	0	0	0	0	0	0	0	0

### Bit 31 – BUSY DMA Sequencing Busy

The bit is set when the DMA sequencing is enabled or restarted.  
The bit is cleared when the DMA sequencing is disabled.

### Bit 8 – OFFSETCORR Offset Correction

Value	Description
0	DMA update of the Offset Correction register is complete or disabled.
1	DMA update of the Offset Correction register is enabled.

### Bit 7 – GAINCORR Gain Correction

Value	Description
0	DMA update of the Gain Correction register is complete or disabled.
1	DMA update of the Gain Correction register is enabled.

### Bit 6 – WINUT Window Monitor Upper Threshold

Value	Description
0	DMA update of the Window Monitor Upper Threshold register is complete or disabled.
1	DMA update of the Window Monitor Upper Threshold register is enabled.

### Bit 5 – WINLT Window Monitor Lower Threshold

Value	Description
0	DMA update of the Window Monitor Lower Threshold register is complete or disabled.
1	DMA update of the Window Monitor Lower Threshold register is enabled.

### Bit 4 – SAMPCTRL Sampling Time Control

Value	Description
0	DMA update of the Sampling Time Control register is complete or disabled.

Value	Description
1	DMA update of the Sampling Time Control register is enabled.

**Bit 3 – AVGCTRL** Average Control

Value	Description
0	DMA update of the Average Control register is complete or disabled.
1	DMA update of the Average Control register is enabled.

**Bit 2 – REFCTRL** Reference Control

Value	Description
0	DMA update of the Reference Control register is complete or disabled.
1	DMA update of the Reference Control register is enabled.

**Bit 1 – CTRLB** Control B

Value	Description
0	DMA update of the Control B register is complete or disabled.
1	DMA update of the Control B register is enabled.

**Bit 0 – INPUTCTRL** Input Control

Value	Description
0	DMA update of the Input Control register is complete or disabled.
1	DMA update of the Input Control register is enabled.

## 51.7.22 Result

**Name:** RESULT  
**Offset:** 0x40  
**Reset:** 0x0000  
**Property:** -

Bit	15	14	13	12	11	10	9	8
	RESULT[15:8]							
Access	R	R	R	R	R	R	R	R
Reset	0	0	0	0	0	0	0	0
Bit	7	6	5	4	3	2	1	0
	RESULT[7:0]							
Access	R	R	R	R	R	R	R	R
Reset	0	0	0	0	0	0	0	0

### Bits 15:0 – RESULT[15:0] Result Conversion Value

These bits will hold up to a 16-bit ADC conversion result, depending on the configuration.

In single conversion mode without averaging, the ADC conversion will produce a 12-bit result, which can be left- or right-shifted, depending on the setting of CTRLB.LEFTADJ.

If the result is left-adjusted (CTRLB.LEFTADJ), the high byte of the result will be in bit position [15:8], while the remaining 4 bits of the result will be placed in bit locations [7:4]. This can be used only if an 8-bit result is needed; i.e., one can read only the high byte of the entire 16-bit register.

If the result is not left-adjusted (CTRLB.LEFTADJ) and no oversampling is used, the result will be available in bit locations [11:0], and the result is then 12 bits long. If oversampling is used, the result will be located in bit locations [15:0], depending on the settings of the Average Control register.

### 51.7.23 RESS

**Name:** RESS  
**Offset:** 0x44  
**Reset:** 0x0000  
**Property:** -

Bit	15	14	13	12	11	10	9	8
RESS[15:8]								
Access	R	R	R	R	R	R	R	R
Reset	0	0	0	0	0	0	0	0
Bit	7	6	5	4	3	2	1	0
RESS[7:0]								
Access	R	R	R	R	R	R	R	R
Reset	0	0	0	0	0	0	0	0

**Bits 15:0 – RESS[15:0]** Last ADC Conversion Result  
 These bits will hold up the last ADC conversion result.

## 51.7.24 Calibration

**Name:** CALIB  
**Offset:** 0x48  
**Reset:** 0x0000  
**Property:** PAC Write-Protection, Enable-Protected

Bit	15	14	13	12	11	10	9	8	
							BIASREFBUF[2:0]		
Access							R/W	R/W	R/W
Reset							0	0	0
Bit	7	6	5	4	3	2	1	0	
			BIASR2R[2:0]			BIASCOMP[2:0]			
Access	R/W		R/W		R/W	R/W	R/W	R/W	
Reset	0		0		0	0	0	0	

### Bits 10:8 – BIASREFBUF[2:0] Bias Reference Buffer Scaling

This value from production test must be loaded from the NVM software calibration row into the CALIB register by software to achieve the specified accuracy. Refer to [NVM Software Calibration Area Mapping](#) for further details.

The value must be copied only, and must not be changed.

### Bits 6:4 – BIASR2R[2:0] Bias R2R ampli Scaling

This value from production test must be loaded from the NVM software calibration row into the CALIB register by software to achieve the specified accuracy. Refer to [NVM Software Calibration Area Mapping](#) for further details.

The value must be copied only, and must not be changed.

### Bits 2:0 – BIASCOMP[2:0] Bias Comparator Scaling

This value from production test must be loaded from the NVM software calibration row into the CALIB register by software to achieve the specified accuracy. Refer to [NVM Software Calibration Area Mapping](#) for further details.

The value must be copied only, and must not be changed.



## 52. Analog Comparators (AC)

### 52.1 Overview

The Analog Comparator (AC) supports two individual comparators. Each comparator (COMP) compares the voltage levels on two inputs, and provides a digital output based on this comparison. Each comparator may be configured to generate interrupt requests and/or peripheral events upon several different combinations of input change.

Hysteresis can be adjusted to achieve optimal operation for each application.

The input selection includes four shared analog port pins (only two, AIN[5:4], for CMP2 and CMP3 on E and G variants) and several internal signals. Each Comparator Output state can also be output on a pin for use by external devices.

The comparators are grouped in pairs on each port. The AC peripheral implements pair of comparators. These are called Comparator 0 (COMP0) and Comparator 1 (COMP1). They have identical behaviors, but separate Control registers. The pair can be set in Window mode to compare a signal to a voltage range instead of a single voltage level.

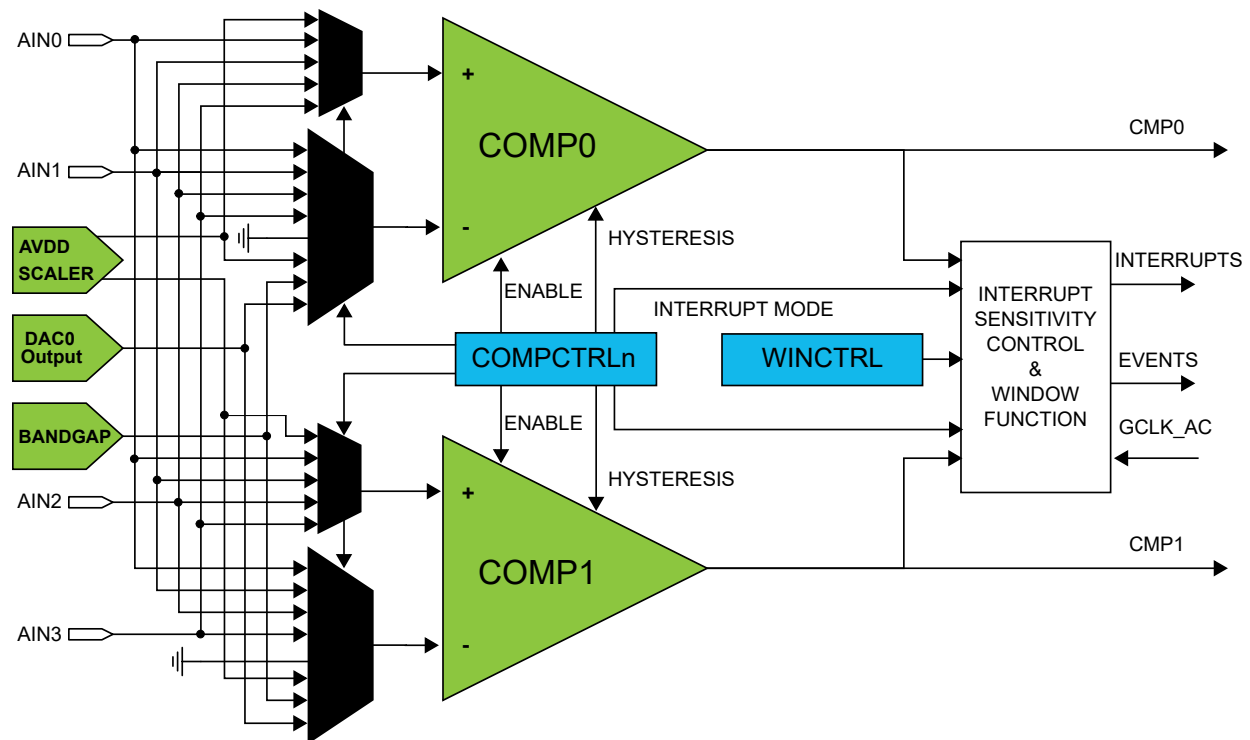
### 52.2 Features

The following are key features of the AC module:

- Up to Two individual comparators
- Selectable hysteresis: 3-level On, or Off
- Hysteresis: On or Off
- Analog comparator outputs available on pins
  - Asynchronous or synchronous
- Flexible input selection:
  - Four pins selectable for positive or negative inputs
  - Ground (for zero crossing)
  - Bandgap reference voltage
  - 64-level programmable AVDD scaler per comparator
  - DAC0
- Interrupt generation on:
  - Rising or falling edge
  - Toggle
  - End of comparison
- Window function interrupt generation on:
  - Signal above window
  - Signal inside window
  - Signal below window
  - Signal outside window
- Event generation on:
  - Comparator output
  - Window function inside/outside window
- Optional digital filter on comparator output

## 52.3 Block Diagram

Figure 52-1. Analog Comparator Block Diagram



## 52.4 Signal Description

Signal	Description	Type
AIN[3..0]	Analog input	Comparator inputs
CMP[1..0]	Digital output	Comparator outputs

Refer to the [Pinout](#) for details on the pin mapping for this peripheral. One signal can be mapped on several pins.

## 52.5 Peripheral Dependencies

<b>Peripheral Name</b>	AC – Analog Comparators
<b>Base Address</b>	0x4200_2000 (Peripheral Bus C)
<b>NVIC IRQ Index:Source</b>	122 : COMP0, COMP1, WIN0
<b>MCLK APB Clock (1)</b>	CLK_AC_APB, Disabled, APBCMASK.AC
<b>GCLK Peripheral Channel Index:Clock Name (2)</b>	32 : GCLK_AC
<b>PAC Peripheral Identifier (PAC.WRCTRL)</b>	72
<b>EVSYS Users (EVSYS.USERm) (3)</b>	59,60 : Start of Comparator x, x=0,1 (AC_SOC 0..1) (A)
<b>EVSYS Generators (EVSYS.CHANNELn)</b>	107,108 : AC Comparator x, x=0,1 (AC_COMPx) 109 : AC0 Window (AC_WIN)
<b>Notes:</b>	
1. Clock Name, Default State, Mask Field.	
2. See GCLK.PCHCTRLm Register, where m = Index.	
3. (A,S,R): A = Asynchronous path, S = Synchronous path, R = Resynchronized path.	

### 52.5.1 I/O Lines

Using the AC's I/O lines requires the I/O pins to be configured. Refer to [PORT - I/O Pin Controller](#) for details.

Table 52-1. I/O Lines

Instance	Signal	Peripheral Function
AC0	AIN0	A
AC0	AIN1	A
AC0	AIN2	A
AC0	AIN3	A
AC0	CMP0	A
AC0	CMP1	A

### 52.5.2 Power Management

The AC will continue to operate in any Sleep mode where the selected source clock is running. The AC's interrupts can be used to wake up the device from Sleep modes. Events connected to the [Event System](#) can trigger other operations in the system without exiting Sleep modes.

### 52.5.3 Clocks

The AC bus clock (CLK\_AC\_APB) can be enabled and disabled in the Main Clock module, MCLK (see [MCLK - Main Clock](#)), and the default state of CLK\_AC\_APB can be found in [Peripheral Clock Masking](#).

A generic clock (GCLK\_AC) is required to clock the AC. This clock must be configured and enabled in the generic clock controller before using the AC. Refer to the [Generic Clock Controller](#) chapter for details.

This generic clock is asynchronous to the bus clock (CLK\_AC\_APB). Due to this asynchronicity, writes to certain registers will require synchronization between the clock domains. Refer to [Synchronization](#) for further details.

### 52.5.4 Debug Operation

When the CPU is halted in debug mode, the AC will halt normal operation after any on-going comparison is completed. The AC can be forced to continue normal operation during debugging. Refer to [DBGCTRL](#) for details. If the AC is configured in a way that requires it to be periodically serviced by the CPU through interrupts or similar, improper operation or data loss may result during debugging.

### 52.5.5 Register Access Protection

All registers with write access can be write-protected optionally by the [Peripheral Access Controller \(PAC\)](#), except for the following registers:

- Control B register (CTRLB)
- Interrupt Flag register (INTFLAG)

Optional write protection by the [Peripheral Access Controller \(PAC\)](#) is denoted by the "PAC Write Protection" property in each individual register description.

PAC write protection does not apply to accesses through an external debugger.

### 52.5.6 Analog Connections

Each comparator has up to four I/O pins that can be used as analog inputs. Each pair of comparators shares the same four pins. These pins must be configured for analog operation before using them as comparator inputs.

Any internal reference source, such as a bandgap voltage reference, or DAC must be configured and enabled prior to its use as a comparator input.

## 52.5.7 Calibration

The BIAS calibration value from the production test must be loaded from the [NVM Software Calibration Area](#) into the AC Calibration register (CALIB) by software to achieve specified accuracy.

## 52.6 Functional Description

### 52.6.1 Principle of Operation

Each comparator has one positive input and one negative input. Each positive input may be chosen from a selection of analog input pins. Each negative input may be chosen from a selection of both analog input pins and internal inputs, such as a bandgap voltage reference.

The digital output from the comparator is '1' when the difference between the positive and the negative input voltage is positive, and '0' otherwise.

The individual comparators can be used independently (Normal mode) or paired to form a window comparison (Window mode).

### 52.6.2 Basic Operation

#### 52.6.2.1 Initialization

Some registers are enable-protected, meaning they can only be written when the module is disabled.

The following register is enable-protected:

- Event Control register (EVCTRL)

Enable-protection is denoted by the "Enable-Protected" property in each individual register description.

#### 52.6.2.2 Enabling, Disabling and Resetting

The AC is enabled by writing a '1' to the Enable bit in the Control A register (CTRLA.ENABLE). The AC is disabled writing a '0' to CTRLA.ENABLE.

The AC is reset by writing a '1' to the Software Reset bit in the Control A register (CTRLA.SWRST). All registers in the AC will be reset to their initial state, and the AC will be disabled. Refer to [CTRLA](#) for details.

#### 52.6.2.3 Comparator Configuration

Each individual comparator must be configured by its respective Comparator Control register (COMPCTRLn) before that comparator is enabled. These settings cannot be changed while the comparator is enabled.

- Select the desired measurement mode with COMPCTRLn.SINGLE. See [Starting a Comparison](#) for more details.
- Select the desired hysteresis with COMPCTRLn.HYSTEN and COMPCTRLn.HYST. See [Input Hysteresis](#) for more details.
- Write COMPCTRLn.SPEED
- Select the interrupt source with COMPCTRLn.INTSEL
- Select the positive and negative input sources with the COMPCTRLn.MUXPOS and COMPCTRLn.MUXNEG bits. See [Selecting Comparator Inputs](#) for more details.
- Select the filtering option with COMPCTRLn.FLEN
- Select standby operation with Run in Standby bit (COMPCTRLn.RUNSTDBY)

The individual comparators are enabled by writing a '1' to the Enable bit in the Comparator x Control registers (COMPCTRLn.ENABLE). The individual comparators are disabled by writing a '0' to COMPCTRLn.ENABLE. Writing a '0' to CTRLA.ENABLE will also disable all the comparators, but will not clear their COMPCTRLn.ENABLE bits.

### 52.6.2.4 Starting a Comparison

Each comparator channel can be in one of two different measurement modes, determined by the COMPCTRLn.SINGLE bit:

- Continuous measurement
- Single-shot

After being enabled, a start-up delay is required before the result of the comparison is ready. This start-up time is measured automatically to account for environmental changes, such as temperature or voltage supply level, and is specified in the *Electrical Characteristics* chapters. During the start-up time, the COMP output is not predictable until the Comparator x Ready bit in the Status B register (STATUSB.READYx) is set.

The comparator can be configured to generate interrupts when the output toggles, when the output changes from '0' to '1' (rising edge), when the output changes from '1' to '0' (falling edge) or at the end of the comparison. An end-of-comparison interrupt can be used with the Single-Shot mode to chain further events in the system, regardless of the state of the comparator outputs. The Interrupt mode is set by the Interrupt Selection bit group in the Comparator Control register (COMPCTRLn.INTSEL). Events are generated using the comparator output state, regardless of whether the interrupt is enabled or not.

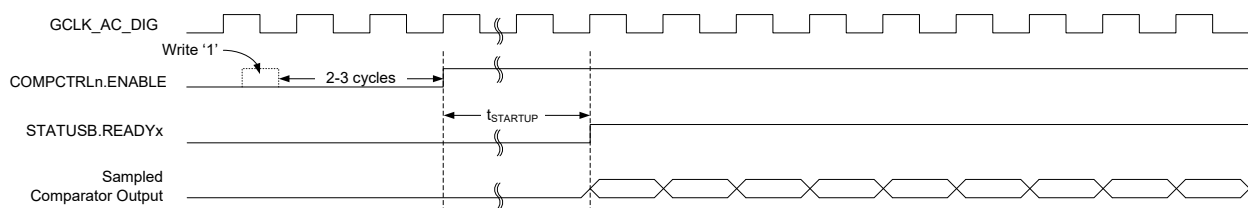
#### 52.6.2.4.1 Continuous Measurement

Continuous measurement is selected by writing COMPCTRLn.SINGLE to zero. In continuous mode, the comparator is continuously enabled and performing comparisons. This ensures that the result of the latest comparison is always available in the Current State bit in the Status A register (STATUSA.STATEx).

After the start-up time has passed, a comparison is done and STATUSA is updated. The Comparator x Ready bit in the Status B register (STATUSB.READYx) is set, and the appropriate peripheral events and interrupts are also generated. New comparisons are performed continuously until the COMPCTRLn.ENABLE bit is written to zero. The start-up time applies only to the first comparison.

In continuous operation, edge detection of the comparator output for interrupts is done by comparing the current and previous sample. The sampling rate is the GCLK\_AC frequency. An example of continuous measurement is shown in the following figure.

**Figure 52-2.** Continuous Measurement Example



For low-power operation, comparisons can be performed during sleep modes without a clock. The comparator is enabled continuously, and changes of the comparator state are detected asynchronously. When a toggle occurs, the Power Manager will start GCLK\_AC to register the appropriate peripheral events and interrupts. The GCLK\_AC clock is then disabled again automatically, unless configured to wake up the system from sleep.

#### 52.6.2.4.2 Single-Shot

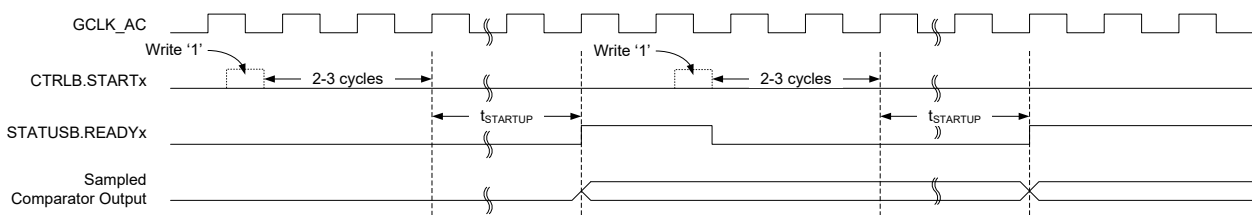
Single-shot operation is selected by writing COMPCTRLn.SINGLE to '1'. During single-shot operation, the comparator is normally idle. The user starts a single comparison by writing '1' to the respective Start Comparison bit in the write-only Control B register (CTRLB.STARTx). The comparator is enabled, and after the start-up time has passed, a single comparison is done and STATUSA.STATEx is updated. Appropriate peripheral events and interrupts are also generated. No new comparisons will be performed.

Writing '1' to CTRLB.STARTx also clears the Comparator x Ready bit in the Status B register (STATUSB.READYx). STATUSB.READYx is set automatically by hardware after the single comparison has completed.

A single-shot measurement can also be triggered by the Event System. Setting the Comparator x Event Input bit in the Event Control Register (EVCTRL.COMPEIx) enables triggering on incoming peripheral events. Each comparator can be triggered independently by separate events. Event-triggered operation is similar to user-triggered operation; the difference is that a peripheral event from another hardware module causes the hardware to automatically start the comparison and clear STATUSB.READYx.

To detect an edge of the comparator output in single-shot operation for the purpose of interrupts, the result of the current measurement is compared with the result of the previous measurement (one sampling period earlier). An example of single-shot operation is shown in the following figure.

**Figure 52-3. Single-Shot Example**



For low-power operation, event-triggered measurements can be performed during sleep modes. When the event occurs, the Power Manager will start GCLK\_AC. The comparator is enabled, and after the startup time has passed, a comparison is done and appropriate peripheral events and interrupts are also generated. The comparator and GCLK\_AC are then disabled again automatically, unless configured to wake up the system from sleep.

### 52.6.3 Selecting Comparator Inputs

Each comparator has one positive and one negative input. The positive input is one of the external input pins (AINx). The negative input can be fed either from an external input pin (AINx) or from one of the several internal reference voltage sources common to all comparators. The user selects the input source as follows:

- The positive input is selected by the Positive Input MUX Select bit group in the Comparator Control register (COMPCTRLn.MUXPOS)
- The negative input is selected by the Negative Input MUX Select bit group in the Comparator Control register (COMPCTRLn.MUXNEG)

In the case of using an external I/O pin, the selected pin must be configured for analog use in the PORT Controller by disabling the digital input and output. The switching of the analog input multiplexers is controlled to minimize crosstalk between the channels. The input selection must be changed only while the individual comparator is disabled.

**Note:** For internal use of the comparison results by the CCL, this bit must be 0x1 or 0x2.

### 52.6.4 Window Operation

Each comparator pair can be configured to work together in Window mode. In this mode, a voltage range is defined, and the comparators give information about whether an input signal is within this range or not. Window mode is enabled by the Window Enable x bit in the Window Control register (WINCTRL.WENx). Both comparators in a pair must have the same measurement mode setting in their respective Comparator Control Registers (COMPCTRLn.SINGLE).

**Notes:**

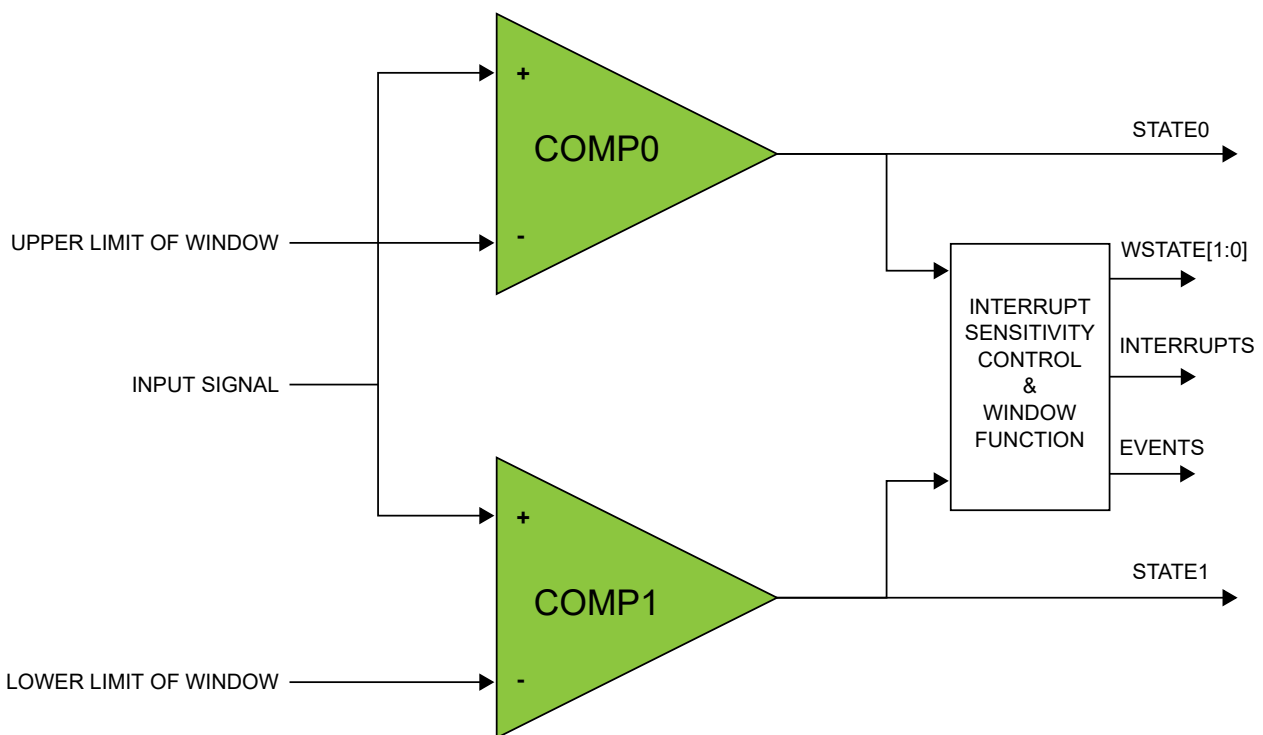
1. Both comparators must be enabled (COMPCTRLn.ENABLE = 1) before the Window mode is enabled (WINCTRL.WEN0 = 1).
2. Window mode must be first disabled (WINCTRL.WEN0 = 0) before both comparators are disabled (COMPCTRLn.ENABLE = 0).
3. Both comparators ready bits must be checked (STATUSB.READYx = 1) before reading measurement results.

To physically configure the pair of comparators for Window mode, the same I/O pin must be chosen as positive input for each comparator, providing a shared input signal. The negative inputs define the range for the window. In the following figure, COMP0 defines the upper limit and COMP1 defines the lower limit of the window, as shown but the window will also work in the opposite configuration with COMP0 lower and COMP1 higher. The current state of the window function is available in the Window x State bit group of the Status register (STATUSA.WSTATEx).

Window mode can be configured to generate interrupts when the input voltage reaches values below the window, above the window, inside the window or outside of the window. The interrupt selections are set by the Window Interrupt Selection bit field in the Window Control register (WINCTRL.WINTSEL). Events are generated using the inside/outside state of the window, regardless of whether the interrupt is enabled or not. Note that the individual comparator outputs, interrupts and events continue to function normally during Window mode.

When the comparators are configured for Window mode and Single-shot mode, measurements are performed simultaneously on both comparators. Writing '1' to either Start Comparison bit in the Control B register (CTRLB.STARTx) will start a measurement. Likewise either peripheral event can start a measurement.

**Figure 52-4.** Comparators in Window Mode

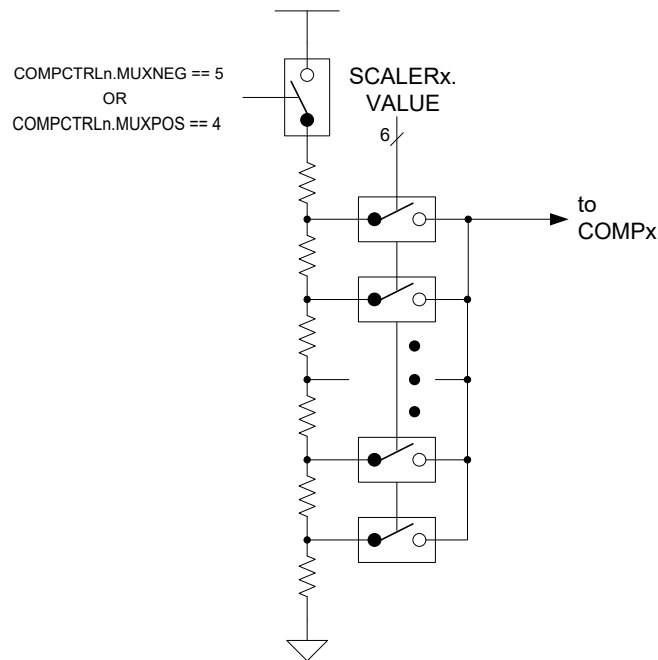


**52.6.5 VDD Scaler**

The VDD scaler generates a reference voltage that is a fraction of the device's supply voltage, with 64 levels. One independent voltage channel is dedicated for each comparator. The scaler of

a comparator is enabled when the Negative Input Mux bit field or the Positive Input Mux in the respective Comparator Control register (COMPCTRLn.MUXNEG, or COMPCTRLn.MUXPOS) is set to 0x5 for Negative Input or 0x04 for Positive Input and the comparator is enabled. The voltage of each channel is selected by the Value bit field in the SCALERx registers (SCALERx.VALUE).

Figure 52-5. VDD Scaler



### 52.6.6 Input Hysteresis

Application software can selectively enable/disable hysteresis for the comparison. Applying hysteresis will help prevent constant toggling of the output, which can be caused by noise when the input signals are close to each other.

Hysteresis is enabled for each comparator individually by the Hysteresis Enable bit in the Comparator x Control register (COMPCTRLn.HYSTEN). Furthermore, when enabled, the level of hysteresis is programmable through the Hysteresis Level bits also in the Comparator x Control register (COMPCTRLn.HYST). Hysteresis is available only in Continuous mode (COMPCTRLn.SINGLE=0).

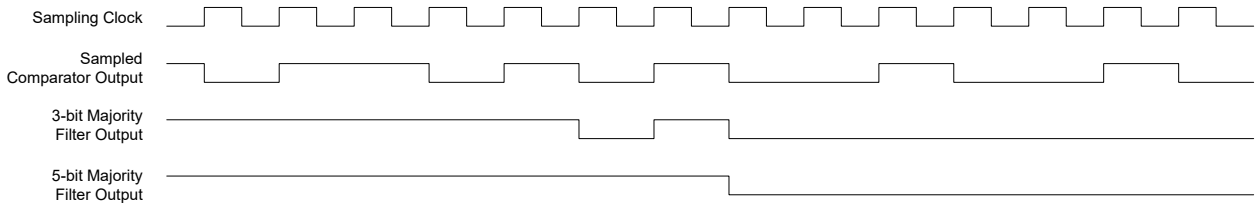
### 52.6.7 Filtering

The output of the comparators can be filtered digitally to reduce noise. The filtering is determined by the Filter Length bits in the Comparator Control x register (COMPCTRLn.FLEN), and is independent for each comparator. Filtering is selectable from none, 3-bit majority (N=3) or 5-bit majority (N=5) functions. Any change in the comparator output is considered valid only if  $N/2+1$  out of the last N samples agree. The filter sampling rate is the GCLK\_AC frequency.

Note that filtering creates an additional delay of N-1 sampling cycles from when a comparison is started until the comparator output is validated. For Continuous mode, the first valid output will occur when the required number of filter samples is taken. Subsequent outputs will be generated every cycle based on the current sample plus the previous N-1 samples, as shown in the following figure.

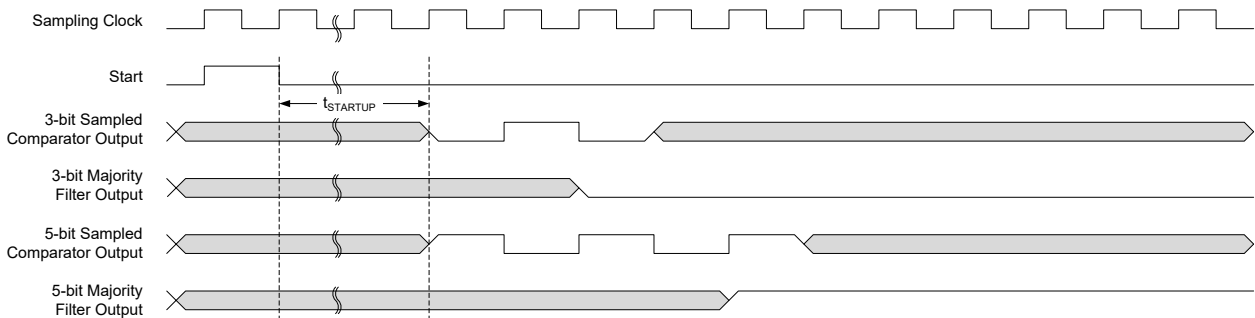


**Figure 52-6. Continuous Mode Filtering**



For Single-shot mode, the comparison completes after the Nth filter sample, as shown in the following figure.

**Figure 52-7. Single-Shot Filtering**



During Sleep modes, filtering is supported only for single-shot measurements. Filtering must be disabled if continuous measurements will be done during Sleep modes, or the resulting interrupt/event may be generated incorrectly.

### 52.6.8 Comparator Output

The output of each comparator can be routed to an I/O pin by setting the Output bit group in the Comparator Control n register (COMPCTRLn.OUT). This allows the comparator to be used by external circuitry. Either the raw, non-synchronized output of the comparator or the CLK\_AC-synchronized version, including filtering, can be used as the I/O signal source. The output appears on the corresponding CMP[x] pin.

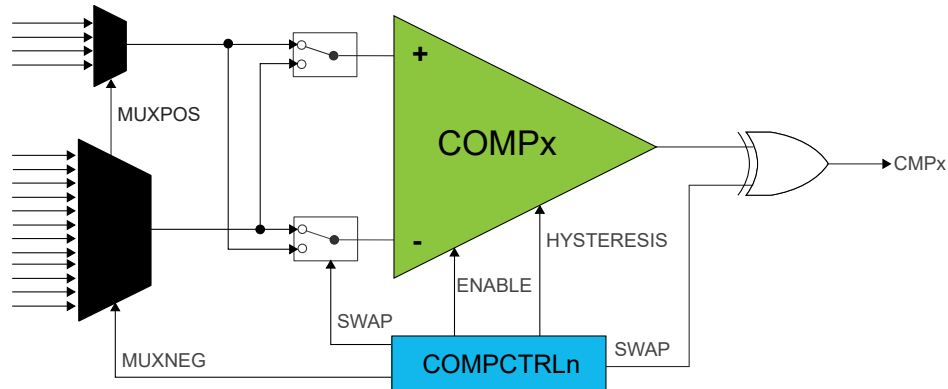
### 52.6.9 Offset Compensation

The Swap bit in the Comparator Control registers (COMPCTRLn.SWAP) controls switching of the input signals to a comparator's positive and negative terminals. When the comparator terminals are swapped, the output signal from the comparator is also inverted, as shown in the following figure.

**Note:** The output signal from the comparator is inverted only if the comparator inputs difference is within offset values.

This allows the user to measure or compensate for the comparator input offset voltage. As part of the input selection, COMPCTRLn.SWAP can be changed only while the comparator is disabled.

Figure 52-8. Input Swapping for Offset Compensation



### 52.6.10 Interrupts

The AC has the following interrupt sources:

- Comparator (COMP0, COMP1): Indicates a change in comparator status.
- Window (WIN0): Indicates a change in the window status.

Comparator interrupts are generated based on the conditions selected by the Interrupt Selection bit group in the Comparator Control registers (COMPCTRLn.INTSEL). Window interrupts are generated based on the conditions selected by the Window Interrupt Selection bit group in the Window Control register (WINCTRL.WINTSEL[1:0]).

Each interrupt source has an interrupt flag associated with it. The interrupt flag in the Interrupt Flag Status and Clear (INTFLAG) register is set when the interrupt condition occurs. Each interrupt can be individually enabled by writing a one to the corresponding bit in the Interrupt Enable Set (INTENSET) register, and disabled by writing a one to the corresponding bit in the Interrupt Enable Clear (INTENCLR) register. The status of enabled interrupts can be read from either INTENSET or INTENCLR.

An interrupt request is generated when the interrupt flag is set and the corresponding interrupt is enabled. The interrupt request remains active until the interrupt flag is cleared, the interrupt is disabled, or the AC is Reset. See [INTFLAG](#) register for details on how to clear interrupt flags. All interrupt requests from the peripheral are ORed together on system level to generate one combined interrupt request to the [NVIC](#). The user must read the INTFLAG register to determine which interrupt condition is present.

Note that interrupts must be globally enabled for interrupt requests to be generated.

### 52.6.11 Events

The AC can generate the following output events:

- Comparator (COMP0, COMP1): Generated as a copy of the comparator status
- Window (WIN0): Generated as a copy of the window inside/outside status

Writing a one to an Event Output bit in the Event Control Register (EVCTRL.xxEO) enables the corresponding output event. Writing a zero to this bit disables the corresponding output event. Refer to the Event System chapter for details on configuring the event system.

The AC can take the following action on an input event (COMP0-1):

- Start comparison

Writing a one to an Event Input bit into the Event Control register (EVCTRL.COMPEIx) enables the corresponding action on input event. Writing a zero to this bit disables the corresponding action on input event. Note that if several events are connected to the AC, the enabled action will be taken on

any of the incoming events. Refer to the Event System chapter for details on configuring the event system.

When EVCTRL.COMPEIx is one, the event will start a comparison on COMPx after the start-up time delay. In normal mode, each comparator responds to its corresponding input event independently. For a pair of comparators in window mode, either comparator event will trigger a comparison on both comparators simultaneously.

### 52.6.12 Sleep Mode Operation

The Run in Standby bits in the Comparator x Control registers (COMPCTRLn.RUNSTDBY) control the behavior of the AC during standby sleep mode. Each RUNSTDBY bit controls one comparator. When the bit is zero, the comparator is disabled during sleep, but maintains its current configuration. When the bit is one, the comparator continues to operate during sleep. Note that when RUNSTDBY is zero, the analog blocks are powered off for the lowest power consumption. This necessitates a start-up time delay when the system returns from sleep.

For Window Mode operation, both comparators in a pair must have the same RUNSTDBY configuration.

When RUNSTDBY is one, any enabled AC interrupt source can wake up the CPU. The AC can also be used during sleep modes where the clock used by the AC is disabled, provided that the AC is still powered (not in shutdown). In this case, the behavior is slightly different and depends on the measurement mode, as listed in the following table.

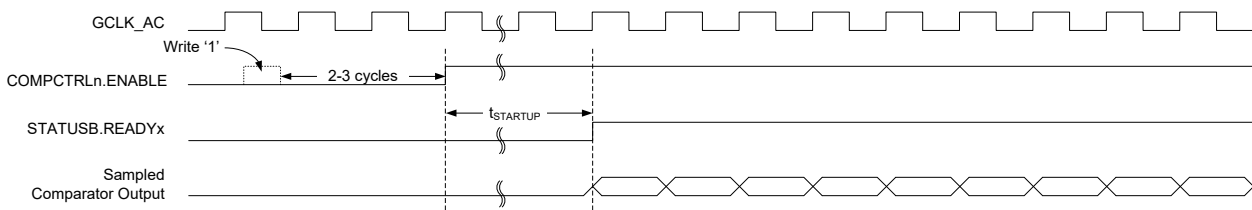
**Table 52-2.** Sleep Mode Operation

COMPCTRLn.MODE	RUNSTDBY=0	RUNSTDBY=1
0 (Continuous)	COMPx disabled	GCLK_AC stopped, COMPx enabled
1 (Single-shot)	COMPx disabled	GCLK_AC stopped, COMPx enabled only when triggered by an input event

#### 52.6.12.1 Continuous Measurement during Sleep

When a comparator is enabled in continuous measurement mode and GCLK\_AC is disabled during sleep, the comparator will remain continuously enabled and will function asynchronously. The current state of the comparator is asynchronously monitored for changes. If an edge matching the interrupt condition is found, GCLK\_AC is started to register the interrupt condition and generate events. If the interrupt is enabled in the Interrupt Enable registers (INTENCLR/SET), the AC can wake up the device; otherwise GCLK\_AC is disabled until the next edge detection. Filtering is not possible with this configuration.

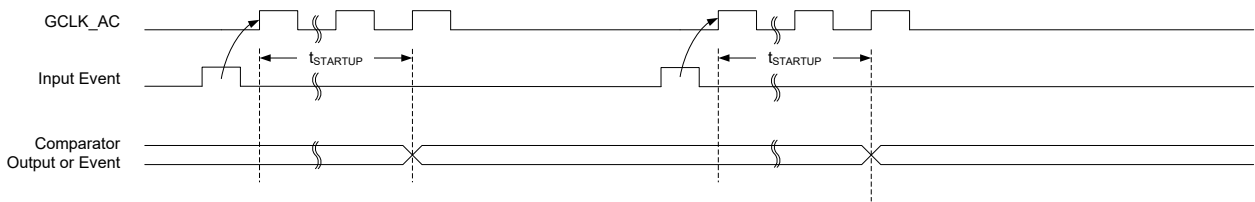
**Figure 52-9.** Continuous Mode SleepWalking



#### 52.6.12.2 Single-Shot Measurement during Sleep

For low-power operation, event-triggered measurements can be performed during sleep modes. When the event occurs, the Power Manager will start GCLK\_AC. The comparator is enabled, and after the start-up time has passed, a comparison is done, with filtering if desired, and the appropriate peripheral events and interrupts are also generated, as shown in the following figure. The comparator and GCLK\_AC are then disabled again automatically, unless configured to wake the system from sleep. Filtering is allowed with this configuration.

**Figure 52-10.** Single-Shot SleepWalking



### 52.6.13 Synchronization

Due to asynchronicity between the main clock domain and the peripheral clock domains, some registers need to be synchronized when written or read.

The following bits are synchronized when written:

- Software Reset bit in Control register (CTRLA.SWRST)
- Enable bit in Control register (CTRLA.ENABLE)
- Enable bit in Comparator Control register (COMPCTRLn.ENABLE)

The following registers are synchronized when written:

- Window Control register (WINCTRL)

Required write synchronization is denoted by the "Write-Synchronized" property in the register description.

## 52.7 Register Summary

Offset	Name	Bit Pos.	7	6	5	4	3	2	1	0
0x00	CTRLA	7:0							ENABLE	SWRST
0x01	CTRLB	7:0							START1	START0
0x02	EVCTRL	7:0				WINEO0			COMPEO1	COMPEO0
		15:8			INVEI1	INVEI0			COMPEI1	COMPEI0
0x04	INTENCLR	7:0				WIN0			COMP1	COMP0
0x05	INTENSET	7:0				WIN0			COMP1	COMP0
0x06	INTFLAG	7:0				WIN0			COMP1	COMP0
0x07	STATUSA	7:0			WSTATE0[1:0]				STATE1	STATE0
0x08	STATUSB	7:0							READY1	READY0
0x09	DBGCTRL	7:0								DBGRUN
0x0A	WINCTRL	7:0						WINTSELO[1:0]		WEN0
0x0B	Reserved									
0x0C	SCALER0	7:0			VALUE[5:0]					
0x0D	SCALER1	7:0			VALUE[5:0]					
0x0E	Reserved									
0x0F										
0x10	COMPCTRL0	7:0		RUNSTDBY		INTSEL[1:0]		SINGLE	ENABLE	
		15:8	SWAP		MUXPOS[2:0]			MUXNEG[2:0]		
		23:16			HYST[1:0]		HYSTEN		SPEED[1:0]	
		31:24			OUT[1:0]				FLEN[2:0]	
0x14	COMPCTRL1	7:0		RUNSTDBY		INTSEL[1:0]		SINGLE	ENABLE	
		15:8	SWAP		MUXPOS[2:0]			MUXNEG[2:0]		
		23:16			HYST[1:0]		HYSTEN		SPEED[1:0]	
		31:24			OUT[1:0]				FLEN[2:0]	
0x18	Reserved									
0x1F										
0x20	SYNCBUSY	7:0				COMPCTRL1	COMPCTRL0	WINCTRL	ENABLE	SWRST
		15:8								
		23:16								
		31:24								
0x24	CALIB	7:0							BIAS0[1:0]	
		15:8								

## 52.7.1 Control A

**Name:** CTRLA  
**Offset:** 0x00  
**Reset:** 0x00  
**Property:** PAC Write-Protection, Write-Synchronized Bits

Bit	7	6	5	4	3	2	1	0
							ENABLE	SWRST
Access							R/W	W
Reset							0	0

### Bit 1 – ENABLE Enable

Due to synchronization, there is delay from updating the register until the peripheral is enabled/disabled. The value written to CTRL.ENABLE will read back immediately and the corresponding bit in the Synchronization Busy register (SYNCBUSY.ENABLE) will be set. SYNCBUSY.ENABLE is cleared when the peripheral is enabled/disabled.

**Note:** To avoid spurious interrupts from enable/disable cycles, use the SWRST bit to reset the comparator module.

Value	Description
0	The AC is disabled.
1	The AC is enabled. Each comparator must also be enabled individually by the Enable bit in the Comparator Control register (COMPCTRLn.ENABLE).

### Bit 0 – SWRST Software Reset

Writing a '0' to this bit has no effect.

Writing a '1' to this bit resets all registers in the AC to their initial state, and the AC will be disabled. Writing a '1' to CTRLA.SWRST will always take precedence, meaning that all other writes in the same write-operation will be discarded.

Due to synchronization, there is a delay from writing CTRLA.SWRST until the reset is complete. CTRLA.SWRST and SYNCBUSY.SWRST will both be cleared when the reset is complete.

**Notes:**

1. When the CTRLA.SWRST is written, the user must poll the SYNCBUSY.SWRST bit to know when the reset operation is complete.
2. During a SWRST, access to registers/bits without the SWRST are disallowed until the SYNCBUSY.SWRST is cleared by hardware.

Value	Description
0	There is no reset operation ongoing.
1	The reset operation is ongoing.

## 52.7.2 Control B

**Name:** CTRLB  
**Offset:** 0x01  
**Reset:** 0x00  
**Property:** -

Bit	7	6	5	4	3	2	1	0
Access							R/W	R/W
Reset							0	0

### Bits 0, 1 – STARTx Comparator x Start Comparison

Writing a '0' to this field has no effect.

Writing a '1' to STARTx starts a single-shot comparison on COMPx if both the Single-Shot and Enable bits in the Comparator x Control Register are '1' (COMPCTRLn.SINGLE and COMPCTRLn.ENABLE). If comparator x is not implemented, or if it is not enabled in single-shot mode, Writing a '1' has no effect.

This bit always reads as zero.

### 52.7.3 Event Control

**Name:** EVCTRL  
**Offset:** 0x02  
**Reset:** 0x0000  
**Property:** PAC Write-Protection, Enable-Protected

Bit	15	14	13	12	11	10	9	8
			INVEI1	INVEI0			COMPEI1	COMPEI0
Access			R/W	R/W			R/W	R/W
Reset			0	0			0	0
Bit	7	6	5	4	3	2	1	0
				WINEO0			COMPEO1	COMPEO0
Access				R/W			R/W	R/W
Reset				0			0	0

#### Bits 12, 13 – INVEIx Inverted Event Input Enable x

Value	Description
0	Incoming event is not inverted for comparator x.
1	Incoming event is inverted for comparator x.

#### Bits 8, 9 – COMPEIx Comparator x Event Input

Note that several actions can be enabled for incoming events. If several events are connected to the peripheral, the enabled action will be taken for any of the incoming events. There is no way to tell which of the incoming events caused the action.

These bits indicate whether a comparison will start or not on any incoming event.

Value	Description
0	Comparison will not start on any incoming event.
1	Comparison will start on any incoming event.

#### Bit 4 – WINEO0 Window 0 Event Output Enable

These bits indicate whether the window 0 function can generate a peripheral event or not.

Value	Description
0	Window 0 Event is disabled.
1	Window 0 Event is enabled.

#### Bits 0, 1 – COMPEOx Comparator x Event Output Enable

These bits indicate whether the comparator x output can generate a peripheral event or not.

Value	Description
0	COMPx event generation is disabled.
1	COMPx event generation is enabled.



## 52.7.4 Interrupt Enable Clear

**Name:** INTENCLR  
**Offset:** 0x04  
**Reset:** 0x00  
**Property:** PAC Write-Protection

This register allows the user to disable an interrupt without doing a read-modify-write operation. Changes in this register will also be reflected in the Interrupt Enable Set register (INTENSET).

Bit	7	6	5	4	3	2	1	0
				WIN0			COMP1	COMP0
Access				R/W			R/W	R/W
Reset				0			0	0

### Bit 4 – WIN0 Window 0 Interrupt Enable

Reading this bit returns the state of the Window 0 interrupt enable.  
 Writing a '0' to this bit has no effect.  
 Writing a '1' to this bit disables the Window 0 interrupt.

Value	Description
0	The Window 0 interrupt is disabled.
1	The Window 0 interrupt is enabled.

### Bits 0, 1 – COMPx Comparator x Interrupt Enable

Reading this bit returns the state of the Comparator x interrupt enable.  
 Writing a '0' to this bit has no effect.  
 Writing a '1' to this bit disables the Comparator x interrupt.

Value	Description
0	The Comparator x interrupt is disabled.
1	The Comparator x interrupt is enabled.

## 52.7.5 Interrupt Enable Set

**Name:** INTENSET  
**Offset:** 0x05  
**Reset:** 0x00  
**Property:** PAC Write-Protection

This register allows the user to enable an interrupt without doing a read-modify-write operation. Changes in this register will also be reflected in the Interrupt Enable Clear register (INTENCLR).

Bit	7	6	5	4	3	2	1	0
				WIN0			COMP1	COMP0
Access				R/W			R/W	R/W
Reset				0			0	0

### Bit 4 – WIN0 Window 0 Interrupt Enable

Reading this bit returns the state of the Window 0 interrupt enable.  
 Writing a '0' to this bit has no effect.  
 Writing a '1' to this bit enables the Window 0 interrupt.

Value	Description
0	The Window 0 interrupt is disabled.
1	The Window 0 interrupt is enabled.

### Bits 0, 1 – COMPx Comparator x Interrupt Enable

Reading this bit returns the state of the Comparator x interrupt enable.  
 Writing a '0' to this bit has no effect.  
 Writing a '1' to this bit will set the Ready interrupt bit and enable the Ready interrupt.

Value	Description
0	The Comparator x interrupt is disabled.
1	The Comparator x interrupt is enabled.

## 52.7.6 Interrupt Flag Status and Clear

**Name:** INTFLAG  
**Offset:** 0x06  
**Reset:** 0x00  
**Property:** -

Bit	7	6	5	4	3	2	1	0
Access				WIN0			COMP1	COMP0
Reset				R/W			R/W	R/W
				0			0	0

### Bit 4 - WIN0 Window 0

This flag is set according to the Window 0 Interrupt Selection bit group in the [WINCTRL](#) register (WINCTRL.WINTSELx) and will generate an interrupt if INTENCLR/SET.WINx is also one. Writing a '0' to this bit has no effect. Writing a '1' to this bit clears the Window 0 interrupt flag.

### Bits 0, 1 - COMPx Comparator x

Reading this bit returns the status of the Comparator x interrupt flag. If comparator x is not implemented, COMPx always reads as zero. This flag is set according to the Interrupt Selection bit group in the Comparator n Control register (COMPCTRLn.INTSEL) and will generate an interrupt if INTENCLR/SET.COMPx is also one. Writing a '0' to this bit has no effect. Writing a '1' to this bit clears the Comparator x interrupt flag.

## 52.7.7 Status A

**Name:** STATUSA  
**Offset:** 0x07  
**Reset:** 0x00  
**Property:** -

Bit	7	6	5	4	3	2	1	0
			WSTATE0[1:0]				STATE1	STATE0
Access			R	R			R	R
Reset			0	0			0	0

### Bits 5:4 – WSTATE0[1:0] Window 0 Current State

These bits show the current state of the signal if the window 0 mode is enabled. When polling for sample completion use both the STATUSB.READYx bits to signal completion.

Value	Name	Description
0x0	ABOVE	Signal is above window
0x1	INSIDE	Signal is inside window
0x2	BELOW	Signal is below window
0x3	-	Reserved

### Bits 0, 1 – STATEx Comparator x Current State

This bit shows the current state of the output signal from COMPx. STATEx is valid only when STATUSB.READYx is one.

### 52.7.8 Status B

**Name:** STATUSB  
**Offset:** 0x08  
**Reset:** 0x00  
**Property:** -

Bit	7	6	5	4	3	2	1	0
							READY1	READY0
Access							R	R
Reset							0	0

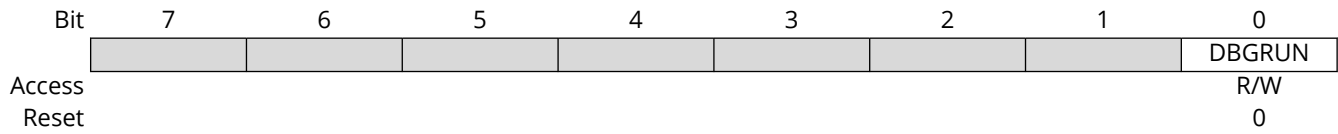
**Bits 0, 1 – READYx** Comparator x Ready

This bit is cleared when the comparator x output is not ready.

This bit is set when the comparator x output is ready.

### 52.7.9 Debug Control

**Name:** DBGCTRL  
**Offset:** 0x09  
**Reset:** 0x00  
**Property:** PAC Write-Protection



#### Bit 0 – DBGRUN Debug Run

This bit is not reset by a software reset.

This bit controls the functionality when the CPU is halted by an external debugger.

Value	Description
0	The AC is halted when the CPU is halted by an external debugger. Any on-going comparison will complete.
1	The AC continues normal operation when the CPU is halted by an external debugger.

### 52.7.10 Window Control

**Name:** WINCTRL  
**Offset:** 0x0A  
**Reset:** 0x00  
**Property:** PAC Write-Protection, Write-Synchronized

**Note:** This register is write-synchronized: SYNCBUSY.WINCTRL must be checked to ensure the WINCTRL register synchronization is complete.

Bit	7	6	5	4	3	2	1	0
						WINTSELO[1:0]		WENO
Access						R/W	R/W	R/W
Reset						0	0	0

#### Bits 2:1 – WINTSELO[1:0] Window 0 Interrupt Selection

These bits configure the interrupt mode for the comparator window 0 mode.

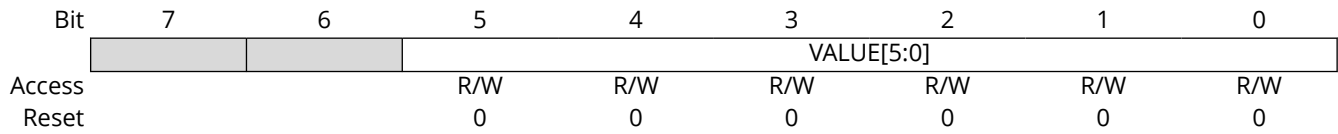
Value	Name	Description
0x0	ABOVE	Interrupt on signal above window
0x1	INSIDE	Interrupt on signal inside window
0x2	BELOW	Interrupt on signal below window
0x3	OUTSIDE	Interrupt on signal outside window

#### Bit 0 – WENO Window 0 Mode Enable

Value	Description
0	Window mode is disabled for comparators 0 and 1.
1	Window mode is enabled for comparators 0 and 1.

### 52.7.11 Scaler n

**Name:** SCALER  
**Offset:** 0x0C + n\*0x01 [n=0..1]  
**Reset:** 0x00  
**Property:** PAC Write-Protection



#### Bits 5:0 – VALUE[5:0] Scaler Value

These bits define the scaling factor for channel n of the AVDD voltage scaler. The output voltage,  $V_{SCALE}$ , is:

$$V_{SCALE} = \frac{V_{DD} \cdot (VALUE+1)}{64}$$



## 52.7.12 Comparator Control n

**Name:** COMPCTRLn  
**Offset:** 0x10 + n\*0x04 [n=0..1]  
**Reset:** 0x00000000  
**Property:** PAC Write-Protection, Write-Synchronized

**Note:** This register is write-synchronized: SYNCBUSY.COMPCTRLn must be checked to ensure the COMPCTRLn register synchronization is complete.

Bit	31	30	29	28	27	26	25	24
			OUT[1:0]				FLEN[2:0]	
Access			R/W	R/W		R/W	R/W	R/W
Reset			0	0		0	0	0
Bit	23	22	21	20	19	18	17	16
			HYST[1:0]		HYSTEN			SPEED[1:0]
Access			R/W	R/W	R/W		R/W	R/W
Reset			0	0	0		0	0
Bit	15	14	13	12	11	10	9	8
	SWAP	MUXPOS[2:0]					MUXNEG[2:0]	
Access	R/W	R/W	R/W	R/W		R/W	R/W	R/W
Reset	0	0	0	0		0	0	0
Bit	7	6	5	4	3	2	1	0
	RUNSTDBY				INTSEL[1:0]		SINGLE	ENABLE
Access		R/W		R/W	R/W	R/W	R/W	
Reset		0		0	0	0	0	

### Bits 29:28 – OUT[1:0] Output

These bits configure the output selection for comparator n. COMPCTRLn.OUT can be written only while COMPCTRLn.ENABLE is zero.

**Note:** For internal use of the comparison results by the CCL, this bit must be 0x1 or 0x2.

These bits are not synchronized.

Value	Name	Description
0x0	OFF	The output of COMPn is not routed to the COMPn I/O port
0x1	ASYN	The asynchronous output of COMPn is routed to the COMPn I/O port
0x2	SYNC	The synchronous output (including filtering) of COMPn is routed to the COMPn I/O port
0x3	N/A	Reserved

### Bits 26:24 – FLEN[2:0] Filter Length

These bits configure the filtering for comparator n. COMPCTRLn.FLEN can only be written while COMPCTRLn.ENABLE is zero.

These bits are not synchronized.

Value	Name	Description
0x0	OFF	No filtering
0x1	MAJ3	3-bit majority function (2 of 3)
0x2	MAJ5	5-bit majority function (3 of 5)
0x3–0x7	N/A	Reserved

### Bits 21:20 – HYST[1:0] Hysteresis Level

These bits indicate the hysteresis level of comparator n when hysteresis is enabled (COMPCTRLn.HYSTEN=1). Hysteresis is available only for continuous mode (COMPCTRLn.SINGLE=0). COMPCTRLn.HYST can be written only while COMPCTRLn.ENABLE is zero. These bits are not synchronized.

Value	Name	Description
0x0	HYST25	25mV
0x1	HYST50	50mV
0x2	HYST75	75mV
0x3	HYST100	100mV

### Bit 19 – HYSTEN Hysteresis Enable

This bit indicates the hysteresis mode of comparator n. Hysteresis is available only for continuous mode (COMPCTRLn.SINGLE=0). This bit is not synchronized.

Value	Description
0	Hysteresis is disabled.
1	Hysteresis is enabled.

### Bits 17:16 – SPEED[1:0] Speed Selection

This bitfield must be written to 0x3 for each comparator n. COMPCTRLn.SPEED can be written only while COMPCTRLn.ENABLE is zero. These bits are not synchronized.

Value	Name	Description
0x0	LOW	Low Power
0x1 – 0x2	-	Reserved
0x3	HIGH	High Speed

### Bit 15 – SWAP Swap Inputs and Invert

This bit swaps the positive and negative inputs to COMPn and inverts the output. This function can be used for offset cancellation. COMPCTRLn.SWAP can be written only while COMPCTRLn.ENABLE is zero.

These bits are not synchronized.

Value	Description
0	The output of MUXPOS connects to the positive input, and the output of MUXNEG connects to the negative input.
1	The output of MUXNEG connects to the positive input, and the output of MUXPOS connects to the negative input.

### Bits 14:12 – MUXPOS[2:0] Positive Input Mux Selection

These bits select which input will be connected to the positive input of comparator n. COMPCTRLn.MUXPOS can be written only while COMPCTRLn.ENABLE is zero.

These bits are not synchronized.

Value	Name	Description
0x0	PIN0	I/O pin 0
0x1	PIN1	I/O pin 1
0x2	PIN2	I/O pin 2
0x3	PIN3	I/O pin 3
0x4	VSCALE	AVDD scaler
0x5–0x7	-	Reserved

### Bits 10:8 – MUXNEG[2:0] Negative Input Mux Selection

These bits select which input will be connected to the negative input of comparator n. COMPCTRLn.MUXNEG can only be written while COMPCTRLn.ENABLE is zero.

These bits are not synchronized.

Value	Name	Description
0x0	PIN0	I/O pin 0
0x1	PIN1	I/O pin 1
0x2	PIN2	I/O pin 2
0x3	PIN3	I/O pin 3
0x4	AVSS	Ground
0x5	VSCALE	AVDD scaler
0x6	BANDGAP	Internal bandgap voltage
0x7	DAC0	DAC0 output

#### Bit 6 - RUNSTDBY Run in Standby

This bit controls the behavior of the comparator during standby sleep mode. This bit is not synchronized.

Value	Description
0	The comparator is disabled during sleep.
1	The comparator continues to operate during sleep.

#### Bits 4:3 - INTSEL[1:0] Interrupt Selection

These bits select the condition for comparator n to generate an interrupt or event. COMPCTRLn.INTSEL can be written only while COMPCTRLn.ENABLE is zero. These bits are not synchronized.

Value	Name	Description
0x0	TOGGLE	Interrupt on comparator output toggle
0x1	RISING	Interrupt on comparator output rising
0x2	FALLING	Interrupt on comparator output falling
0x3	EOC	Interrupt on end of comparison (single-shot mode only)

#### Bit 2 - SINGLE Single-Shot Mode

This bit determines the operation of comparator n. COMPCTRLn.SINGLE can be written only while COMPCTRLn.ENABLE is zero. These bits are not synchronized.

Value	Description
0	Comparator n operates in continuous measurement mode.
1	Comparator n operates in single-shot mode.

#### Bit 1 - ENABLE Enable

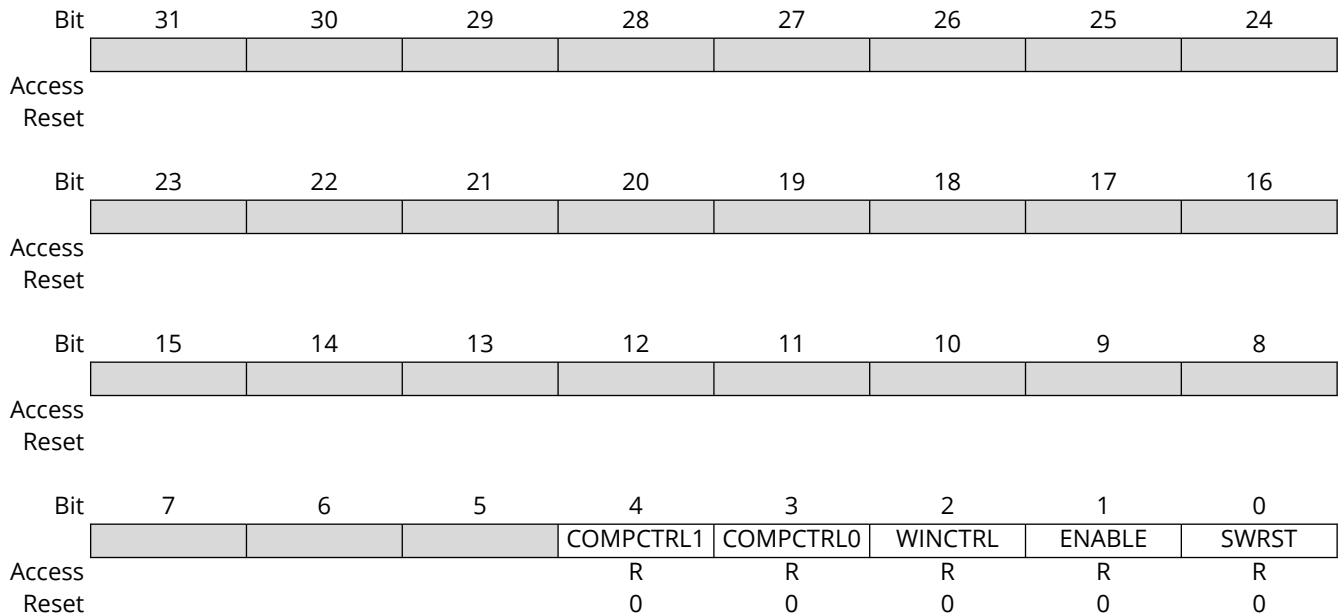
Writing a zero to this bit disables comparator n. Writing a one to this bit enables comparator n.

Due to synchronization, there is delay from updating the register until the comparator is enabled/disabled. The value written to COMPCTRLn.ENABLE will read back immediately after being written. SYNCBUSY.COMPCTRLn is set. SYNCBUSY.COMPCTRLn is cleared when the peripheral is enabled/disabled.

Writing a one to COMPCTRLn.ENABLE will prevent further changes to the other bits in COMPCTRLn. These bits remain protected until COMPCTRLn.ENABLE is written to zero and the write is synchronized.

### 52.7.13 Synchronization Busy

**Name:** SYNCBUSY  
**Offset:** 0x20  
**Reset:** 0x00000000  
**Property:** -



#### Bits 3, 4 – COMPCTRLn COMPCTRLn Synchronization Busy

This bit is cleared when the synchronization of the COMPCTRLn register between the clock domains is complete.

This bit is set when the synchronization of the COMPCTRLn register between clock domains is started.

#### Bit 2 – WINCTRL WINCTRL Synchronization Busy

This bit is cleared when the synchronization of the WINCTRL register between the clock domains is complete.

This bit is set when the synchronization of the WINCTRL register between clock domains is started.

#### Bit 1 – ENABLE Enable Synchronization Busy

This bit is cleared when the synchronization of the CTRLA.ENABLE bit between the clock domains is complete.

This bit is set when the synchronization of the CTRLA.ENABLE bit between clock domains is started.

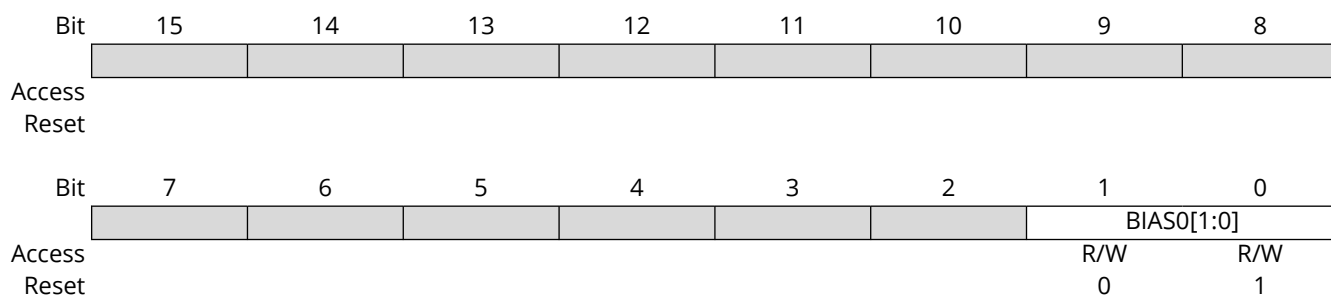
#### Bit 0 – SWRST Software Reset Synchronization Busy

This bit is cleared when the synchronization of the CTRLA.SWRST bit between the clock domains is complete.

This bit is set when the synchronization of the CTRLA.SWRST bit between clock domains is started.

### 52.7.14 Calibration Register

**Name:** CALIB  
**Offset:** 0x24  
**Reset:** 0x0101  
**Property:** Enable-Protect, PAC Write-Protection



**Bits 1:0 – BIAS0[1:0]** COMP0/1 Bias Scaling

This value from production test must be loaded from the [NVM software calibration row](#) into the CALIB register by software to achieve the specified accuracy. The value must be copied only, and must not be changed.

## 53. Digital-to-Analog Converter (DAC)

### 53.1 Overview

The Digital-to-Analog Converter (DAC) converts a digital value to a voltage. The DAC Controller controls two DACs, which can operate either as two independent DACs or as a single DAC in differential mode. Each DAC is 12-bit resolution and is capable of converting up to 1,000,000 samples per second (MSPS).

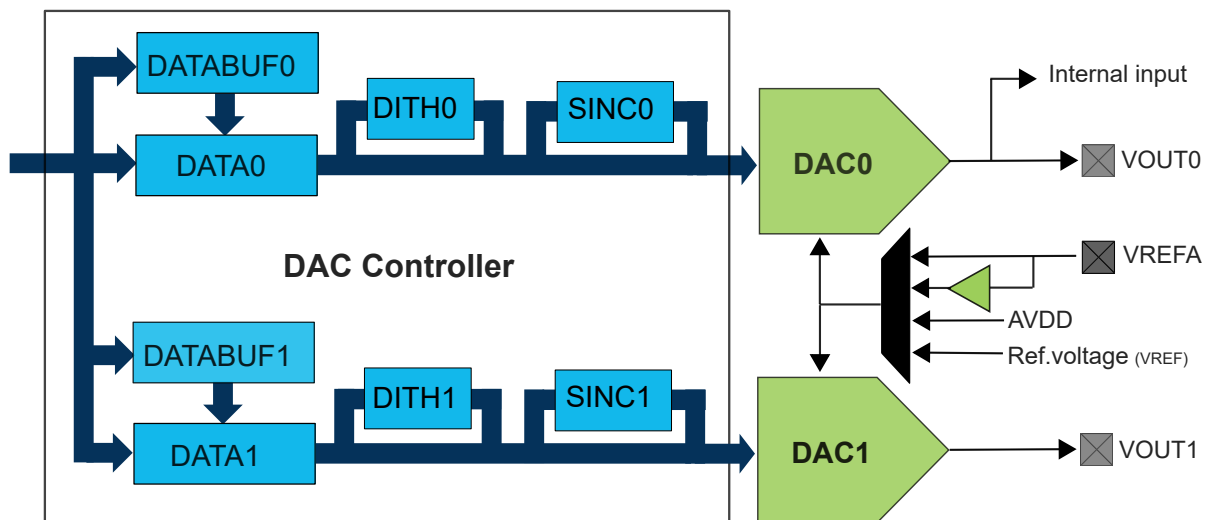
### 53.2 Features

The following are key features of the DAC module:

- Two independent DACs or single DAC in differential mode
- DAC with 12-bit resolution
- Up to 1MSPS conversion rate
- Hardware support for 16-bit using dithering
- Multiple trigger sources
- High-drive capabilities
- DAC0 used as internal input
- DMA support

### 53.3 Block Diagram

Figure 53-1. DAC Controller Block Diagram



### 53.4 Signal Description

Signal	Description	Type
VOUT0	DAC0 output	Analog output
VOUT1	DAC1 output	Analog output
VREFA	External reference	Analog input

One signal can be mapped on several pins.

**Note:** When an analog peripheral is enabled, the analog output of the peripheral will interfere with the alternative functions of the output pads. This is also true even when the peripheral is used for internal purposes.

Analog inputs do not interfere with alternative pad functions.

## 53.5 Peripheral Dependencies

<b>Peripheral Name</b>	DAC – Digital-to-Analog Converter
<b>Base Address</b>	0x4300_2400 (Peripheral Bus D)
<b>NVIC IRQ Index:Source</b>	123 : OVERRUN0, OVERRUN1, UNDERRUN0, UNDERRUN1; 124 : EMPTY0; 125 : EMPTY1; 126 : RESRDY0; 127 : RESRDY1
<b>MCLK APB Clock (1)</b>	CLK_DAC_APB, Disabled, APBDMASK.DAC
<b>GCLK Peripheral Channel Index:Clock Name (2)</b>	42 : GCLK_DAC
<b>PAC Peripheral Identifier (PAC.WRCTRL)</b>	105
<b>DMA Trigger Index:Source (DMAC.CHCTRLAK,k=0,1,...31)</b>	72,73 : EMPTY 74,75 : Result Ready (RESRDY)
<b>EVSYS Users (EVSYS.USERm) (3)</b>	61,62 : DAC0..1 Start Conversion (DAC_START0..1) (A)
<b>EVSYS Generators (EVSYS.CHANNELn)</b>	110,111 : DACx Buffer Empty, x=0..1 (DAC_EMPTYx)
<b>Notes:</b>	
1.	Clock Name, Default State, Mask Field.
2.	See GCLK.PCHCTRLm Register, where m = Index.
3.	(A,S,R): A = Asynchronous path, S = Synchronous path, R = Resynchronized path.

### 53.5.1 I/O Lines

Using the DAC Controller's I/O lines requires the I/O pins to be configured in the [PORT - I/O Pin Controller](#).

**Table 53-1.** I/O Lines

Instance	Signal	Peripheral Function
DAC	VOUT0	A
DAC	VOUT1	A
DAC	VREFA	A

### 53.5.2 Power Management

The DAC Controller will continue to operate in any sleep mode where the selected source clock is running.

The DAC Controller interrupts can be used to wake up the device from sleep modes.

Events connected to the [event system](#) can trigger other operations in the system without exiting sleep modes.

### 53.5.3 Clocks

The DAC bus clock (CLK\_DAC\_APB) can be enabled and disabled in the Main Clock module, and the default state of CLK\_DAC\_APB can be found in [Peripheral Clock Masking](#).

A generic clock (GCLK\_DAC) is required to clock the DAC Controller. This clock must be configured and enabled in the [Generic Clock Controller](#) before using the DAC Controller.

This generic clock is asynchronous to the bus clock (CLK\_DAC\_APB). Due to this asynchronicity, writes to certain registers will require synchronization between the clock domains. Refer to [53.6.8. Synchronization](#) for further details.

### 53.5.4 Debug Operation

When the CPU is halted in debug mode the DAC will halt normal operation. Any on-going conversions will be completed. The DAC can be forced to continue normal operation during

debugging. If the DAC is configured in a way that requires it to be periodically serviced by the CPU through interrupts or similar, improper operation or data loss may result during debugging.

### 53.5.5 Register Access Protection

All registers with write access can be write-protected optionally by the [Peripheral Access Controller \(PAC\)](#), except for the following registers:

- Interrupt Flag Status and Clear (INTFLAG) register
- Data Buffer (DATABUFx) registers

Optional write protection by the [Peripheral Access Controller \(PAC\)](#) is denoted by the "PAC Write Protection" property in each individual register description.

PAC write protection does not apply to accesses through an external debugger.

### 53.5.6 Analog Connections

The DAC has up to two analog output pins (VOUT0, VOUT1) and one analog input pin (VREFA) that must be configured first.

When an internal input is used, it must be enabled before DAC Controller is enabled.

The analog signals of AC, ADC, and DAC can be interconnected.

See *Analog Connections of Peripherals* for details.

## 53.6 Functional Description

### 53.6.1 Principle of Operation

Each DAC converts the digital value located in the Data register (DATA0 or DATA1) into an analog voltage on the DAC output (VOUT0 or VOUT1, respectively).

A conversion is started when new data is loaded to the Data register. The resulting voltage is available on the DAC output after the conversion time. A conversion can also be started by input events from Event System.

### 53.6.2 Basic Operation

#### 53.6.2.1 Initialization

The following registers are enable-protected, meaning they can only be written when the DAC Controller is disabled (CTRLA.ENABLE = 0):

- The Control B register (CTRLB)
- The Event Control register (EVCTRL)
- The DAC0 Control register (DACCTRL0)
- The DAC1 Control register (DACCTRL1)

Enable-protection is denoted by the Enable-Protected property in the register description.

#### 53.6.2.2 Enabling, Disabling and Resetting

The DAC Controller is enabled by writing a '1' to the Enable bit in the Control A register (CTRLA.ENABLE). The DAC Controller is disabled by writing a '0' to CTRLA.ENABLE.

The DAC Controller is reset by writing '1' to the Software Reset bit in the Control A register (CTRLA.SWRST). All registers in the DAC will be reset to their initial state, and the DAC Controller will be disabled. Refer to [53.7.1. CTRLA](#) for details.



### 53.6.2.3 DAC Configuration

Each individual DAC is configured by its respective DAC Control register (DACCTRLx). These settings are applied when DAC Controller is enabled and can be changed only when DAC Controller is disabled.

- Enable the selected DAC by writing a '1' to DACCTRLx.ENABLE.
- Select the data alignment with DACCTRLx.LEFTADJ. Writing a '1' will left-align the data (DATABUFx/DATAx[31:20]). Writing a '0' to LEFTADJ will right-align the data (DATABUFx/DATAx[11:0]).
- If operation in standby mode is desired for DACx, write a '1' to the Run in Standby bit in the DAC Control register (DACCTRLx.RUNSTDBY). If RUNSTDBY = 1, DACx continues normal operation when system is in standby mode. If RUNSTDBY = 0, DACx is halted in standby mode.
- Select dithering mode with DACCTRLx.DITHER. Writing '1' to DITHER will enable dithering mode, writing a '0' will disable it. Refer to [53.6.9.4. Dithering Mode](#) for details.
- Select the output buffer current according to data rate (for low power application) with the Current Control bit field DACCTRLx.CCTRL[1:0]. Refer to [53.6.9.2. Output Buffer Current Control](#) for details.

Once the DAC Controller is enabled, DACx requires a startup time before the first conversion can start. The DACx Startup Ready bit in the Status register (STATUS.READYx) indicates that DACx is ready to convert a data when STATUS.READYx = 1.

Conversions started while STATUS.READYx = 0 shall be discarded.

VOUTx is at tri-state level if DACx is not enabled.

### 53.6.2.4 Digital to Analog Conversion

Each DAC converts a digital value (stored in DATAx register) into an analog voltage. The conversion range is between AVSS and the selected DAC voltage reference VREF. The default source for VREF is the internal reference voltage VREF. Other voltage reference options are the analog supply voltage (AVDD) and the external voltage reference (VREFA). The voltage reference is selected by writing to the Reference Selection bits in the Control B register (CTRLB.REFSEL).

The output voltage from the DAC can be calculated using the following formula:

$$V_{OUTx} = \frac{DATAx}{4095} \times VREF$$

A new conversion starts as soon as a new value is loaded into DATAx. DATAx can either be loaded via the APB bus during a CPU write operation, using DMA, or from the DATABUFx register when a STARTx event occurs.

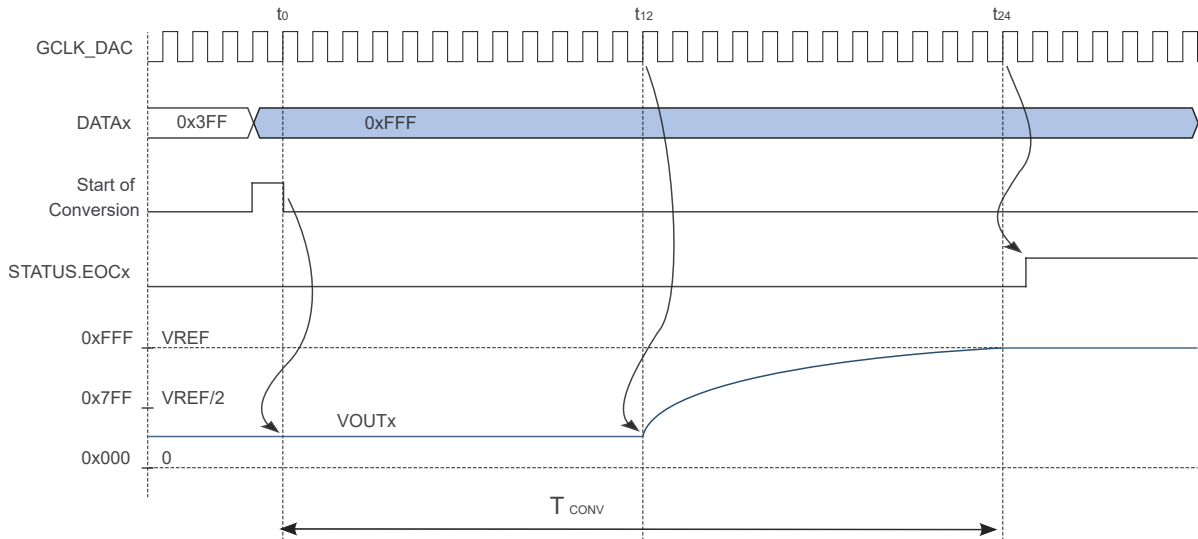
Refer to 'Events' for details. Even if both DAC use the same GCLK, each data conversion can be started independently.

The conversion time is given by the period  $T_{GCLK}$  of the generic clock GCLK\_DAC and the number of bits:

$$T_{CONV} = 12 \times 2 \times T_{GCLK}$$

The End Of Conversion bit in the Status register indicates that a conversion is completed (STATUS.EOCx=1). This means that VOUTx is stable.

**Figure 53-2. Single DAC Conversion**

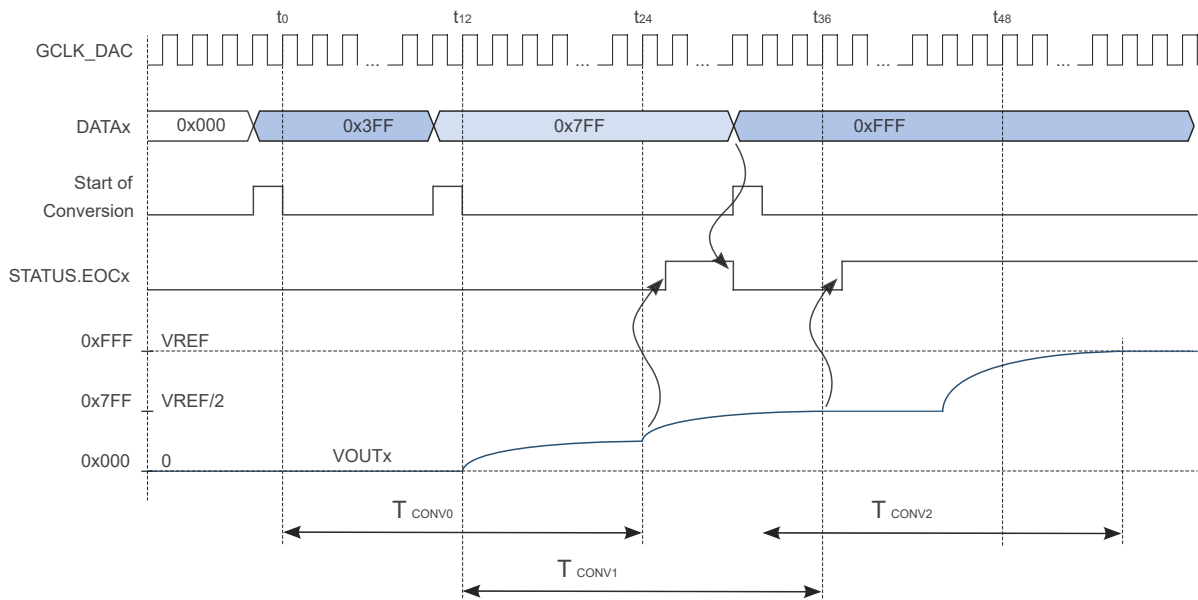


Since the DAC conversion is implemented as pipelined procedure, a new conversion can be started after only 12 GCLK\_DAC periods. Therefore if DATAx is written while a conversion is ongoing, start of conversion is postponed until DACx is ready to start next conversion.

The maximum conversion rate (samples per second) is therefore:

$$CR_{\max} = \frac{2}{T_{\text{conv}}}$$

**Figure 53-3. Multiple DAC Conversions**



### 53.6.3 Operating Conditions

- The DAC voltage reference must be below AVDD.
- The maximum conversion rate of 1MSPS can be achieved only if AVDD is above 2.4V.
- The frequency of GCLK\_DAC must be equal or lower than 12MHz (corresponding to 1MSPS).



**Important:** A minimum DAC Sampling Rate must be respected: refer to [DAC Electrical Characteristics](#).

#### 53.6.4 DMA Operation

In single mode (CTRLB.DIFF=0), DAC Controller generates the following DMA requests:

- Data Buffer 0 Empty (EMPTY0): The request is set when data is transferred from DATABUF0 or DATA0 to the internal data buffer of DAC0. The request is cleared when either DATA0 register or DATABUF0 register is written, or by writing a '1' to the EMPTY0 bit in the Interrupt Flag register (INTFLAG.EMPTY0).
- Data Buffer 1 Empty (EMPTY1): The request is set when data is transferred from DATABUF1 or DATA1 to the internal data buffer of DAC1. The request is cleared when either DATA0 register or DATABUF1 register is written, or by writing a one to the EMPTY1 bit in the Interrupt Flag register (INTFLAG.EMPTY1).

In differential mode (CTRLB.DIFF=1), DAC Controller generates the following DMA request:

- Data Buffer 0 Empty (EMPTY0): The request is set when data is transferred from DATABUF0 or DATA0 to the internal data buffer of DAC1. The request is cleared when either DATA0 register or DATABUF0 register is written, or by writing a one to the EMPTY0 bit in the Interrupt Flag register (INTFLAG.EMPTY0).

If the CPU accesses the registers which are source of DMA request set/clear condition, the DMA request can be lost or the DMA transfer can be corrupted, if enabled.

#### 53.6.5 Interrupts

The DAC Controller has the following interrupt sources:

- DAC0 Data Buffer Empty (EMPTY0): Indicates that the internal data buffer of DAC0 is empty.
- DAC1 Data Buffer Empty (EMPTY1): Indicates that the internal data buffer of DAC1 is empty.
- DAC0 Underrun (UNDERRUN0): Indicates that the internal data buffer of DAC0 is empty and a DAC0 start of conversion event occurred. Refer to 'Events' for details.
- DAC1 Underrun (UNDERRUN1): Indicates that the internal data buffer of DAC1 is empty and a DAC1 start of conversion event occurred. Refer to 'Events' for details.

These interrupts are asynchronous wake-up sources.

Each interrupt source has an interrupt flag associated with it. The interrupt flag in the Interrupt Flag Status and Clear (INTFLAG) register is set when the interrupt condition occurs. Each interrupt can be individually enabled by writing a '1' to the corresponding bit in the Interrupt Enable Set (INTENSET) register, and disabled by writing a '1' to the corresponding bit in the Interrupt Enable Clear (INTENCLR) register.

An interrupt request is generated when the interrupt flag is set and the corresponding interrupt is enabled. The interrupt request remains active until the interrupt flag is cleared, the interrupt is disabled, or the DAC Controller is reset. See [53.7.6. INTFLAG](#) for details on how to clear interrupt flags.

All interrupt requests from the peripheral are ORed together on system level to generate one combined interrupt request to the [NVIC](#). The user must read the INTFLAG register to determine which interrupt condition is present.

Note that interrupts must be globally enabled for interrupt requests to be generated.

#### 53.6.6 Events

The DAC Controller can generate the following output events:

- Data Buffer 0 Empty (EMPTY0): Generated when the internal data buffer of DAC0 is empty. Refer to [53.6.4. DMA Operation](#) for details.
- Data Buffer 1 Empty (EMPTY1): Generated when the internal data buffer of DAC1 is empty. Refer to [53.6.4. DMA Operation](#) for details.

Writing a '1' to an Event Output bit in the Event Control Register (EVCTRL.EMPTYEOx) enables the corresponding output event. Writing a '0' to this bit disables the corresponding output event. Refer to the Event System chapter for details on configuring the event system.

The DAC Controller can take the following actions on an input event:

- DAC0 Start Conversion (START0): DATABUF0 value is transferred into DATA0 as soon as DAC0 is ready for the next conversion, and then conversion is started. START0 is considered as asynchronous to GCLK\_DAC, thus it is resynchronized in the DAC Controller. Refer to [53.6.2.4. Digital to Analog Conversion](#) for details.
- DAC1 Start Conversion (START1): DATABUF1 value is transferred into DATA1 as soon as DAC1 is ready for the next conversion, and then conversion is started. START1 is considered as asynchronous to GCLK\_DAC, thus it is resynchronized in the DAC Controller. Refer to [53.6.2.4. Digital to Analog Conversion](#) for details.

**Note:** When a DACx Start Conversion event is enabled, only DATABUFx must be written (not DATAx).

Writing a '1' to an Event Input bit in the Event Control register (EVCTRL.STARTEIx) enables the corresponding action on input event. Writing a '0' to this bit will disable the corresponding action on input event.

**Note:** When several events are connected to the DAC Controller, the enabled action will be taken on any of the incoming events.

By default, DAC Controller detects rising edge events. Falling edge detection can be enabled by writing '1' to EVCTRL.INVEIx.

Note that if an event occurs before startup time is completed, DATAx is loaded but start of conversion is ignored.

### 53.6.7 Sleep Mode Operation

If the Run In Standby bit in the DAC Control x register DACCCTRLx.RUNSTDBY=1, the DACx will continue the conversions in standby sleep mode.

If DACCCTRLx.RUNSTDBY=0, the DACx will stop conversions in standby sleep mode.

If DACx conversion is stopped in standby sleep mode, DACx is also disabled to reduce power consumption. When exiting standby sleep mode, DACx is enabled again, therefore a certain startup time is required before starting a new conversion.

DAC Controller is compatible with SleepWalking: if RUNSTDBY=1, when an input event (STARTx) is detected in sleep mode, the DAC Controller will request GCLK\_DAC in order to complete the conversion.

### 53.6.8 Synchronization

Due to asynchronicity between the main clock domain and the peripheral clock domains, some registers need to be synchronized when written or read.

An exception is the Channel Enable bit in the Peripheral Channel Control registers (PCHCTRLm.CHEN). When changing this bit, the bit value must be read-back to ensure the synchronization is complete and to assert glitch free internal operation. Changing the bit value under ongoing synchronization will not generate an error.

The following bits are synchronized when written:

- The Software Reset bit in the Control register (CTRLA.SWRST)

- The Enable bit in the Control register (CTRLA.ENABLE)

The following registers are synchronized when written:

- The DAC0 data register (DATA0)
- The DAC1 data register (DATA1)
- The DAC0 data buffer register (DATABUF0)
- The DAC1 data buffer register (DATABUF1)

Required write synchronization is denoted by the "Write-Synchronized" property in the register description.

## 53.6.9 Additional Features

### 53.6.9.1 DAC0 as Internal Input

The analog output of DAC0, VOUT0, is internally available as input signal for other peripherals (AC and ADC) when DAC0 is enabled.

**Note:** The pin VOUT0 will be dedicated as internal input and cannot be configured as alternate function.

### 53.6.9.2 Output Buffer Current Control

Power consumption can be reduced by controlling the output buffer current, according to conversion rate. Writing to the Current Control bits in DAC Control x register (DACCTRLx.[1:0]) will select an output buffer current.

### 53.6.9.3 Differential Mode

DAC0 and DAC1 can be configured to operate in differential mode, i.e. the combined output is a voltage balanced around VREF/2, see also the figure below.

In differential mode, DAC0 and DAC1 are converting synchronously the DATA0 value. DATA0 must therefore be a signed value, represented in two's complement format with DATA0[11] as the signed bit. DATA0 has therefore the range [-2047:2047].

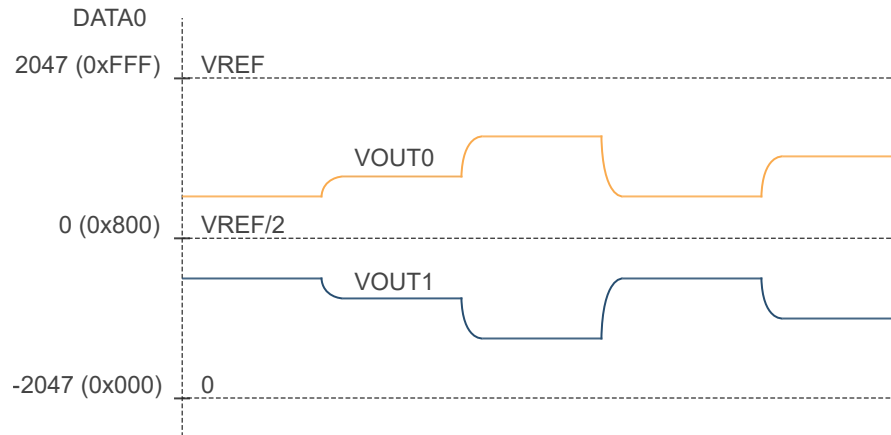
VOUT0 is the positive output and VOUT1 the negative output. The differential output voltage is therefore:

$$V_{OUT} = \frac{DATA0}{2047} \times VREF = (V_{OUT0} - V_{OUT1})$$

DACCTRL0 serves as the configuration register for both DAC0 and DAC1. Therefore DACCTRL1 does not need to be written.

The differential mode is enabled by writing a '1' to the Differential bit in the Control B register (CTRLB.DIFF).

**Figure 53-4.** DAC Conversions in Differential Mode



### 53.6.9.4 Dithering Mode

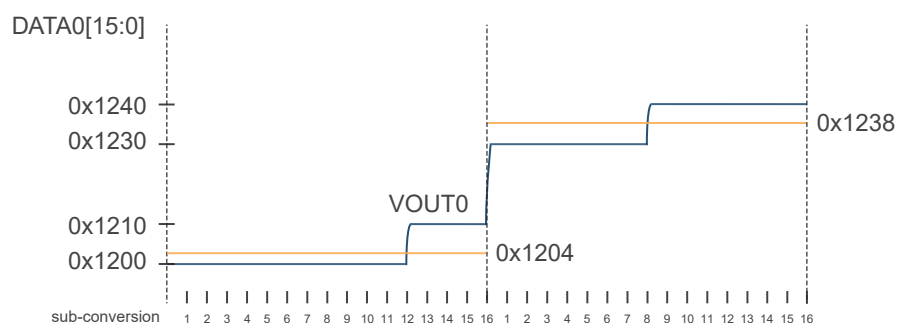
Dithering is enabled by setting `DACCTRLx.DITHER` to 1. In dithering mode, `DATAx` is a 16-bit unsigned value where `DATAx[15:4]` is the 12-bit data converted by DAC and `DATA0x[3:0]` represent the dither bits, used to minimize the quantization error.

The principle is to make 16 sub-conversions of the `DATAx[15:4]` value or the `(DATAx[15:4] + 1)` value, so that by averaging those two values, the conversion result of the 16-bit value (`DATAx[15:0]`) is accurate.

To operate, the `STARTx` event must be configured to generate 16 events for each `DATAx[15:0]` conversion, and `DATABUFx` must be loaded every 16 DAC conversions. `EMPTYx` event and DMA request are therefore generated every 16 `DATABUF0x` to `DATAx` transfer. `STATUS.EOCx` still reports end of each sub-conversions.

Following timing diagram shows examples with `DATA0[15:0] = 0x1204` followed by `DATA0[15:0] = 0x1238`.

**Figure 53-5.** DAC Conversions in Dithering Mode



## 53.7 Register Summary

Offset	Name	Bit Pos.	7	6	5	4	3	2	1	0
0x00	CTRLA	7:0							ENABLE	SWRST
0x01	CTRLB	7:0						REFSEL[1:0]		DIFF
0x02	EVCTRL	7:0			INVEI1	INVEI0	EMPTYEO1	EMPTYEO0	STARTEI1	STARTEI0
0x03	Reserved									
0x04	INTENCLR	7:0					EMPTY1	EMPTY0	UNDERRUN1	UNDERRUN0
0x05	INTENSET	7:0					EMPTY1	EMPTY0	UNDERRUN1	UNDERRUN0
0x06	INTFLAG	7:0					EMPTY1	EMPTY0	UNDERRUN1	UNDERRUN0
0x07	STATUS	7:0					EOC1	EOC0	READY1	READY0
0x08	SYNCBUSY	7:0			DATABUF1	DATABUF0	DATA1	DATA0	ENABLE	SWRST
		15:8								
		23:16								
		31:24								
0x0C	DACCTRL0	7:0	DITHER	RUNSTDBY				CCTRL[1:0]	ENABLE	LEFTADJ
		15:8								
0x0E	DACCTRL1	7:0	DITHER	RUNSTDBY				CCTRL[1:0]	ENABLE	LEFTADJ
		15:8								
0x10	DATA0	7:0								DATA[7:0]
		15:8								DATA[15:8]
0x12	DATA1	7:0								DATA[7:0]
		15:8								DATA[15:8]
0x14	DATABUF0	7:0								DATABUF[7:0]
		15:8								DATABUF[15:8]
0x16	DATABUF1	7:0								DATABUF[7:0]
		15:8								DATABUF[15:8]
0x18	DBGCTRL	7:0								DBGRUN

### 53.7.1 Control A

**Name:** CTRLA  
**Offset:** 0x00  
**Reset:** 0x00  
**Property:** PAC Write-Protection, Write-Synchronized Bits

Bit	7	6	5	4	3	2	1	0
							ENABLE	SWRST
Access							R/W	R/W
Reset							0	0

#### Bit 1 – ENABLE Enable DAC Controller

Due to synchronization there is delay from writing CTRLA.ENABLE until the peripheral is enabled/disabled. The value written to CTRLA.ENABLE will read back immediately and the corresponding bit in the Synchronization Busy register (SYNCBUSY.ENABLE) will be set. SYNCBUSY.ENABLE will be cleared when the operation is complete.

Value	Description
0	The peripheral is disabled.
1	The peripheral is enabled.

#### Bit 0 – SWRST Software Reset

Writing '0' to this bit has no effect.

Writing '1' to this bit resets all registers in the DAC to their initial state, and the DAC will be disabled. Writing a '1' to CTRLA.SWRST will always take precedence, meaning that all other writes in the same write-operation will be discarded.

Due to synchronization there is a delay from writing CTRLA.SWRST until the reset is complete. CTRLA.SWRST and SYNCBUSY.SWRST will both be cleared when the reset is complete.

#### Notes:

1. When the CTRLA.SWRST is written, the user must poll the SYNCBUSY.SWRST bit to know when the reset operation is complete.
2. During a SWRST, access to registers/bits without the SWRST are disallowed until the SYNCBUSY.SWRST is cleared by hardware.

Value	Description
0	There is no reset operation ongoing.
1	The reset operation is ongoing.



## 53.7.2 Control B

**Name:** CTRLB  
**Offset:** 0x01  
**Reset:** 0x02  
**Property:** PAC Write-Protection

Bit	7	6	5	4	3	2	1	0
						REFSEL[1:0]		DIFF
Access						R/W	R/W	R/W
Reset						0	1	0

### Bits 2:1 – REFSEL[1:0] Reference Selection

This bit field selects the Reference Voltage for both DACs.

#### Notes:

1. The reference selection of the DAC will reset to '0' (VREFAU) if the DAC Software Reset (CTRLA.SWRST) is used.
2. When the internal bandgap reference (INTREF) is selected as reference voltage (CTRLB.REFSEL = 0x3), the DAC Startup Ready bits value (STATUS.READY0, STATUS.READY1) is not correct for the first DAC Conversion after device power-up or after wake-up from Standby Low-Power mode. Disregard STATUS.READY0 and STATUS.READY1 bits for the first DAC conversion and check instead that the Data Buffer 0/1 Empty bits are set (INTFLAG.EMPTY0 = 1, INTFLAG.EMPTY1 = 1).

Value	Name	Description
0x0	VREFAU	Unbuffered external voltage reference (not buffered in DAC, direct connection)
0x1	AVDD	Voltage supply
0x2	VREFAB	Buffered external voltage reference (buffered in DAC). This buffered external voltage reference option can be used when the applied external input reference voltage has insufficient drive current.
0x3	INTREF	Internal bandgap reference

### Bit 0 – DIFF Differential Mode Enable

This bit defines the conversion mode for both DACs.

Value	Description
0	Single mode
1	Differential mode

### 53.7.3 Event Control

**Name:** EVCTRL  
**Offset:** 0x02  
**Reset:** 0x00  
**Property:** PAC Write-Protection

Bit	7	6	5	4	3	2	1	0
			INVEI1	INVEI0	EMPTYEO1	EMPTYEO0	STARTEI1	STARTEI0
Access			R/W	R/W	R/W	R/W	R/W	R/W
Reset			0	0	0	0	0	0

**Bit 5 – INVEI1** Enable Inversion of DAC1 Start Conversion Input Event  
This bit defines the detection of the input event for DAC1 START.

Value	Description
0	Input event source is not inverted.
1	Input event source is inverted.

**Bit 4 – INVEI0** Enable Inversion of DAC0 Start Conversion Input Event  
This bit defines the detection of the input event for DAC0 START.

Value	Description
0	Input event source is not inverted.
1	Input event source is inverted.

**Bit 3 – EMPTYEO1** Data Buffer Empty Event Output DAC1  
This bit indicates if the Data Buffer Empty Event output for DAC1 is enabled.

Value	Description
0	Data Buffer Empty event is disabled.
1	Data Buffer Empty event is enabled.

**Bit 2 – EMPTYEO0** Data Buffer Empty Event Output DAC0  
This bit indicates if the Data Buffer Empty Event output for DAC0 is enabled.

Value	Description
0	Data Buffer Empty event is disabled.
1	Data Buffer Empty event is enabled.

**Bit 1 – STARTEI1** Start Conversion Event Input DAC1  
This bit indicates if the Start input event for DAC1 is enabled.

Value	Description
0	A new conversion will not be triggered on any incoming event. Only DATA1 must be written (not DATABUF1).
1	A new conversion will be triggered on any incoming event. Only DATABUF1 must be written (not DATA1).

**Bit 0 – STARTEI0** Start Conversion Event Input DAC0  
This bit indicates if the Start input event for DAC0 is enabled.

Value	Description
0	A new conversion will not be triggered on any incoming event. Only DATA0 must be written (not DATABUF0).
1	A new conversion will be triggered on any incoming event. Only DATABUF0 must be written (not DATA0).

### 53.7.4 Interrupt Enable Clear

**Name:** INTENCLR  
**Offset:** 0x04  
**Reset:** 0x00  
**Property:** PAC Write-Protection

This register allows the user to disable an interrupt without doing a read-modify-write operation. Changes in this register will also be reflected in the Interrupt Enable Set register (INTENSET).

Bit	7	6	5	4	3	2	1	0
					EMPTY1	EMPTY0	UNDERRUN1	UNDERRUN0
Access					R/W	R/W	R/W	R/W
Reset					0	0	0	0

#### Bit 3 – EMPTY1 Data Buffer 1 Empty Interrupt Enable

Writing a '0' to this bit has no effect.

Writing a '1' to this bit will clear the Data Buffer 1 Empty Interrupt Enable bit, which disables the Data Buffer 1 Empty interrupt.

Value	Description
0	The Data Buffer 1 Empty interrupt is disabled.
1	The Data Buffer 1 Empty interrupt is enabled.

#### Bit 2 – EMPTY0 Data Buffer 0 Empty Interrupt Enable

Writing a '0' to this bit has no effect.

Writing a '1' to this bit will clear the Data Buffer 0 Empty Interrupt Enable bit, which disables the Data Buffer 0 Empty interrupt.

Value	Description
0	The Data Buffer 0 Empty interrupt is disabled.
1	The Data Buffer 0 Empty interrupt is enabled.

#### Bit 1 – UNDERRUN1 Underrun Interrupt Enable for DAC1

Writing a '0' to this bit has no effect.

Writing a '1' to this bit will clear the Data Buffer 1 Underrun Interrupt Enable bit, which disables the Data Buffer 1 Underrun interrupt.

Value	Description
0	The Data Buffer 1 Underrun interrupt is disabled.
1	The Data Buffer 1 Underrun interrupt is enabled.

#### Bit 0 – UNDERRUN0 Underrun Interrupt Enable for DAC0

Writing a '0' to this bit has no effect.

Writing a '1' to this bit will clear the Data Buffer 0 Underrun Interrupt Enable bit, which disables the Data Buffer 0 Underrun interrupt.

Value	Description
0	The Data Buffer 0 Underrun interrupt is disabled.
1	The Data Buffer 0 Underrun interrupt is enabled.

### 53.7.5 Interrupt Enable Set

**Name:** INTENSET  
**Offset:** 0x05  
**Reset:** 0x00  
**Property:** PAC Write-Protection

This register allows the user to disable an interrupt without doing a read-modify-write operation. Changes in this register will also be reflected in the Interrupt Enable Clear register (INTENCLR).

Bit	7	6	5	4	3	2	1	0
					EMPTY1	EMPTY0	UNDERRUN1	UNDERRUN0
Access					R/W	R/W	R/W	R/W
Reset					0	0	0	0

#### Bit 3 – EMPTY1 Data Buffer 1 Empty Interrupt Enable

Writing a '0' to this bit has no effect.

Writing a '1' to this bit will set the Data Buffer 1 Empty Interrupt Enable bit, which enables the Data Buffer 1 Empty interrupt.

Value	Description
0	The Data Buffer 1 Empty interrupt is disabled.
1	The Data Buffer 1 Empty interrupt is enabled.

#### Bit 2 – EMPTY0 Data Buffer 0 Empty Interrupt Enable

Writing a '0' to this bit has no effect.

Writing a '1' to this bit will set the Data Buffer 0 Empty Interrupt Enable bit, which enables the Data Buffer 0 Empty interrupt.

Value	Description
0	The Data Buffer 0 Empty interrupt is disabled.
1	The Data Buffer 0 Empty interrupt is enabled.

#### Bit 1 – UNDERRUN1 Underrun Interrupt Enable for DAC1

Writing a '0' to this bit has no effect.

Writing a '1' to this bit will set the Data Buffer 1 Underrun Interrupt Enable bit, which enables the Data Buffer 1 Underrun interrupt.

Value	Description
0	The Data Buffer 1 Underrun interrupt is disabled.
1	The Data Buffer 1 Underrun interrupt is enabled.

#### Bit 0 – UNDERRUN0 Underrun Interrupt Enable for DAC0

Writing a '0' to this bit has no effect.

Writing a '1' to this bit will set the Data Buffer 0 Underrun Interrupt Enable bit, which enables the Data Buffer 0 Underrun interrupt.

Value	Description
0	The Data Buffer 0 Underrun interrupt is disabled.
1	The Data Buffer 0 Underrun interrupt is enabled.

### 53.7.6 Interrupt Flag Status and Clear

**Name:** INTFLAG  
**Offset:** 0x06  
**Reset:** 0x00  
**Property:** -

Bit	7	6	5	4	3	2	1	0
					EMPTY1	EMPTY0	UNDERRUN1	UNDERRUN0
Access					R/W	R/W	R/W	R/W
Reset					0	0	0	0

#### Bit 3 – EMPTY1 Data Buffer 1 Empty

This flag is cleared by writing a '1' to it or by writing new data to DATA1 or DATABUF1.  
This flag is set when the data buffer for DAC1 is empty and will generate an interrupt request if INTENCLR/INTENSET.EMPTY1=1.  
Writing a '0' to this bit has no effect.  
Writing a '1' to this bit will clear the Data Buffer 1 Empty interrupt flag.

#### Bit 2 – EMPTY0 Data Buffer 0 Empty

This flag is cleared by writing a '1' to it or by writing new data to DATA0 or DATABUF0.  
This flag is set when the data buffer for DAC0 is empty and will generate an interrupt request if INTENCLR/INTENSET.EMPTY0=1.  
Writing a '0' to this bit has no effect.  
Writing a '1' to this bit will clear the Data Buffer 0 Empty interrupt flag.

#### Bit 1 – UNDERRUN1 DAC1 Underrun

This flag is cleared by writing a '1' to it.  
This flag is set when a start conversion event (START1) occurred before new data is copied/written to the DAC1 data buffer and will generate an interrupt request if INTENCLR/INTENSET.UNDERRUN1=1.  
Writing a '0' to this bit has no effect.  
Writing a '1' to this bit will clear the DAC1 Underrun interrupt flag.

#### Bit 0 – UNDERRUN0 DAC0 Underrun

This flag is cleared by writing a '1' to it.  
This flag is set when a start conversion event (START0) occurred before new data is copied/written to the DAC) data buffer and will generate an interrupt request if INTENCLR/INTENSET.UNDERRUN0=1.  
Writing a '0' to this bit has no effect.  
Writing a '1' to this bit will clear the DAC0 Underrun interrupt flag.

### 53.7.7 Status

**Name:** STATUS  
**Offset:** 0x07  
**Reset:** 0x00  
**Property:** -

Bit	7	6	5	4	3	2	1	0
					EOC1	EOC0	READY1	READY0
Access					R	R	R	R
Reset					0	0	0	0

#### Bit 3 – EOC1 DAC1 End of Conversion

This bit is cleared when DATA1 register is written.

Value	Description
0	No conversion completed since last load of DATA1.
1	DAC1 conversion is complete, VOUT1 is stable.

#### Bit 2 – EOC0 DAC0 End of Conversion

This bit is cleared when DATA0 register is written.

Value	Description
0	No conversion completed since last load of DATA0.
1	DAC0 conversion is complete, VOUT0 is stable.

#### Bit 1 – READY1 DAC1 Startup Ready

Value	Description
0	DAC1 is not ready for conversion.
1	Startup time has elapsed, DAC1 is ready for conversion.

#### Bit 0 – READY0 DAC0 Startup Ready

Value	Description
0	DAC0 is not ready for conversion.
1	Startup time has elapsed, DAC0 is ready for conversion.

### 53.7.8 Synchronization Busy

**Name:** SYNCBUSY  
**Offset:** 0x08  
**Reset:** 0x00000000  
**Property:** -

Bit	31	30	29	28	27	26	25	24
Access								
Reset								
Bit	23	22	21	20	19	18	17	16
Access								
Reset								
Bit	15	14	13	12	11	10	9	8
Access								
Reset								
Bit	7	6	5	4	3	2	1	0
Access			DATABUF1	DATABUF0	DATA1	DATA0	ENABLE	SWRST
Reset			R	R	R	R	R	R
			0	0	0	0	0	0

#### Bit 5 - DATABUF1 Data Buffer DAC1

This bit is set when DATABUF1 register is written.  
This bit is cleared when DATABUF1 synchronization is completed.

Value	Description
0	No ongoing synchronized access.
1	Synchronized access is ongoing.

#### Bit 4 - DATABUF0 Data Buffer DAC0

This bit is set when DATABUF0 register is written.  
This bit is cleared when DATABUF0 synchronization is completed.

Value	Description
0	No ongoing synchronized access.
1	Synchronized access is ongoing.

#### Bit 3 - DATA1 Data DAC1

This bit is set when DATA1 register is written.  
This bit is cleared when DATA1 synchronization is completed.

Value	Description
0	No ongoing synchronized access.
1	Synchronized access is ongoing.

#### Bit 2 - DATA0 Data DAC0

This bit is set when DATA0 register is written.  
This bit is cleared when DATA0 synchronization is completed.

Value	Description
0	No ongoing synchronized access.
1	Synchronized access is ongoing.

**Bit 1 – ENABLE** DAC Enable Status

This bit is set when CTRLA.ENABLE bit is written.

This bit is cleared when CTRLA.ENABLE synchronization is completed.

Value	Description
0	No ongoing synchronization.
1	Synchronization is ongoing.

**Bit 0 – SWRST** Software Reset

This bit is set when CTRLA.SWRST bit is written.

This bit is cleared when CTRLA.SWRST synchronization is completed.

Value	Description
0	No ongoing synchronization.
1	Synchronization is ongoing.



### 53.7.9 DAC0 Control

**Name:** DACCTRL0  
**Offset:** 0x0C  
**Reset:** 0x0000  
**Property:** PAC Write-Protection, Enabled-Protected

Bit	15	14	13	12	11	10	9	8
Access								
Reset								
Bit	7	6	5	4	3	2	1	0
Access	DITHER	RUNSTDBY			CTRL[1:0]		ENABLE	LEFTADJ
Reset	R/W	R/W			R/W	R/W	R/W	R/W
Reset	0	0			0	0	0	0

#### Bit 7 - DITHER Dithering Mode

Value	Description
0	Dithering mode is disabled.
1	Dithering mode is enabled.

#### Bit 6 - RUNSTDBY Run in Standby

This bit controls the behavior of DAC0 during standby sleep mode.

Value	Description
0	DAC0 is disabled during standby sleep mode.
1	DAC0 continues to operate during standby sleep mode.

#### Bits 3:2 - CTRL[1:0] Current Control

This field defines the current in output buffer according to conversion rate.

##### Current Control

Value	Name	Description
0x0	CC100K	$GCLK\_DAC \leq 1.2\text{MHz}$ (100kSPS)
0x1	CC1M	$1.2\text{MHz} < GCLK\_DAC \leq 6\text{MHz}$ (500kSPS)
0x2	CC12M	$6\text{MHz} < GCLK\_DAC \leq 12\text{MHz}$ (1MSPS)
0x3	Reserved	-

#### Bit 1 - ENABLE Enable DAC0

This bit enables DAC0 when DAC Controller is enabled (CTRLA.ENABLE).

Value	Description
0	DAC0 is disabled.
1	DAC0 is enabled.

#### Bit 0 - LEFTADJ Left Adjusted Data

This bit controls how the 12-bit conversion data is adjusted in the Data and Data Buffer registers.

Value	Description
0	DATA0 and DATABUF0 registers are right-adjusted.
1	DATA0 and DATABUF0 registers are left-adjusted.

### 53.7.10 DAC1 Control

**Name:** DACCTRL1  
**Offset:** 0x0E  
**Reset:** 0x0000  
**Property:** PAC Write-Protection, Enabled-Protected

Bit	15	14	13	12	11	10	9	8
Access								
Reset								
Bit	7	6	5	4	3	2	1	0
Access	DITHER	RUNSTDBY			CTRL[1:0]		ENABLE	LEFTADJ
Reset	R/W	R/W			R/W	R/W	R/W	R/W
Reset	0	0			0	0	0	0

#### Bit 7 - DITHER Dithering Mode

Value	Description
0	Dithering mode is disabled.
1	Dithering mode is enabled.

#### Bit 6 - RUNSTDBY Run in Standby

This bit controls the behavior of DAC1 during standby sleep mode.

Value	Description
0	DAC1 is disabled during standby sleep mode.
1	DAC1 continues to operate during standby sleep mode.

#### Bits 3:2 - CTRL[1:0] Current Control

This field defines the current in output buffer.

##### Current Control

Value	Name	Description
0x0	CC100K	GCLK_DAC ≤ 1.2MHz (100kSPS)
0x1	CC1M	1.2MHz < GCLK_DAC ≤ 6MHz (500kSPS)
0x2	CC12M	6MHz < GCLK_DAC ≤ 12MHz (1MSPS)
0x3		Reserved

#### Bit 1 - ENABLE Enable DAC1

This bit enables DAC1 when DAC Controller is enabled (CTRLA.ENABLE).

Value	Description
0	DAC1 is disabled.
1	DAC1 is enabled.

#### Bit 0 - LEFTADJ Left Adjusted Data

This bit controls how the 12-bit conversion data is adjusted in the Data and Data Buffer registers.

Value	Description
0	DATA1 and DATABUF1 registers are right-adjusted.
1	DATA1 and DATABUF1 registers are left-adjusted.

### 53.7.11 Data DAC0

**Name:** DATA0  
**Offset:** 0x10  
**Reset:** 0x0000  
**Property:** PAC Write-Protection, Write-Synchronized

**Note:** This register is write-synchronized: SYNCBUSY.DATA0 must be checked to ensure the DATA0 register synchronization is complete.

Bit	15	14	13	12	11	10	9	8
	DATA[15:8]							
Access	W	W	W	W	W	W	W	W
Reset	0	0	0	0	0	0	0	0
Bit	7	6	5	4	3	2	1	0
	DATA[7:0]							
Access	W	W	W	W	W	W	W	W
Reset	0	0	0	0	0	0	0	0

#### Bits 15:0 – DATA[15:0] DAC0 Data

DATA0 register contains the 12-bit value that is converted to a voltage by the DAC0. The adjustment of these 12 bits within the 16-bit register is controlled by DACCTRL0.LEFTADJ:

- DATA[11:0] when DACCTRL0.LEFTADJ=0.
- DATA[15:4] when DACCTRL0.LEFTADJ=1.

In dithering mode (whatever DACCTRL0.LEFTADJ value):

- DATA[15:4] are the 12-bit converted by DAC0.
- DATA[3:0] are the dither bits.

### 53.7.12 Data DAC1

**Name:** DATA1  
**Offset:** 0x12  
**Reset:** 0x0000  
**Property:** PAC Write-Protection, Write-Synchronized

**Note:** This register is write-synchronized: SYNCBUSY.DATA1 must be checked to ensure the DATA1 register synchronization is complete.

Bit	15	14	13	12	11	10	9	8
	DATA[15:8]							
Access	W	W	W	W	W	W	W	W
Reset	0	0	0	0	0	0	0	0
Bit	7	6	5	4	3	2	1	0
	DATA[7:0]							
Access	W	W	W	W	W	W	W	W
Reset	0	0	0	0	0	0	0	0

#### Bits 15:0 – DATA[15:0] DAC1 Data

DATA1 register contains the 12-bit value that is converted to a voltage by the DAC1. The adjustment of these 12 bits within the 16-bit register is controlled by DACCTRL1.LEFTADJ:

- DATA[11:0] when DACCTRL1.LEFTADJ=0.
- DATA[15:4] when DACCTRL1.LEFTADJ=1.

In dithering mode (whatever DACCTRL1.LEFTADJ value):

- DATA[15:4] are the 12-bit converted by DAC1.
- DATA[3:0] are the dither bits.

### 53.7.13 Data Buffer DAC0

**Name:** DATABUF0  
**Offset:** 0x14  
**Reset:** 0x0000  
**Property:** Write-Synchronized

**Note:** This register is write-synchronized: SYNCBUSY.DATABUF0 must be checked to ensure the DATABUF0 register synchronization is complete.

Bit	15	14	13	12	11	10	9	8
	DATABUF[15:8]							
Access	W	W	W	W	W	W	W	W
Reset	0	0	0	0	0	0	0	0
Bit	7	6	5	4	3	2	1	0
	DATABUF[7:0]							
Access	W	W	W	W	W	W	W	W
Reset	0	0	0	0	0	0	0	0

#### Bits 15:0 – DATABUF[15:0] DAC0 Data Buffer

DATABUF0 contains the value to be transferred into DATA0 when a START0 event occurs.

### 53.7.14 Data Buffer DAC1

**Name:** DATABUF1  
**Offset:** 0x16  
**Reset:** 0x0000  
**Property:** Write-Synchronized

**Note:** This register is write-synchronized: SYNCBUSY.DATABUF1 must be checked to ensure the DATABUF1 register synchronization is complete.

Bit	15	14	13	12	11	10	9	8
	DATABUF[15:8]							
Access	W	W	W	W	W	W	W	W
Reset	0	0	0	0	0	0	0	0
Bit	7	6	5	4	3	2	1	0
	DATABUF[7:0]							
Access	W	W	W	W	W	W	W	W
Reset	0	0	0	0	0	0	0	0

#### Bits 15:0 – DATABUF[15:0] DAC1 Data Buffer

DATABUF1 contains the value to be transferred into DATA1 when a START1 event occurs.

### 53.7.15 Debug Control

**Name:** DBGCTRL  
**Offset:** 0x18  
**Reset:** 0x00  
**Property:** PAC Write-Protection

Bit	7	6	5	4	3	2	1	0
								DBGRUN
Access								
Reset								0

#### Bit 0 – DBGRUN Debug Run

This bit is not reset by a software reset.

This bit controls the functionality when the CPU is halted by an external debugger.

Value	Description
0	The DAC is halted when the CPU is halted by an external debugger. Any ongoing conversion will complete.
1	The DAC continues normal operation when the CPU is halted by an external debugger.

## 54. Peripheral Touch Controller (PTC)

### 54.1 Overview

The Peripheral Touch Controller (PTC) acquires signals in order to detect a touch on the capacitive sensors. The external capacitive touch sensor is typically formed on a PCB, and the sensor electrodes are connected to the analog front end of the PTC through the I/O pins in the device. The PTC supports both self and mutual capacitance sensors.

In the Mutual Capacitance mode, sensing is done using capacitive touch matrices in various X-Y configurations, including indium tin oxide (ITO) sensor grids. The PTC requires one pin per X-line and one pin per Y-line.

In the Self Capacitance mode, the PTC requires only one pin (Y-line) for each touch sensor.

The number of available pins and the assignment of X- and Y-lines is depending on both package type and device configuration. Refer to the [Configuration Summary](#) and [Pinout](#) for details.

### 54.2 Features

The following are key features of the PTC module:

- Low-Power, High-Sensitivity, Environmentally Robust Capacitive Touch Buttons, Sliders, and Wheels
- Supports Wake-up on Touch from Sleep mode
- Supports Mutual Capacitance and Self Capacitance Sensing
  - Mix-and-Match Mutual and Self Capacitance Sensors
- One Pin per Electrode – No External Components
- Load Compensating Charge Sensing
  - Parasitic capacitance compensation and adjustable gain for superior sensitivity
- Zero Drift Over the Temperature and AVDD Range
  - Auto calibration and recalibration of sensors
- Single-shot and free-running Charge Measurement
- Hardware Noise Filtering and Noise Signal Desynchronization for High Conducted Immunity
- Selectable channel change delay allows choosing the settling time on a new channel, as required
- Acquisition-start triggered by command or through auto-triggering feature
- Low CPU utilization through interrupt on acquisition-complete
- Using ADC peripheral for signal conversion and acquisition



### 54.3 Block Diagram

Figure 54-1. PTC Block Diagram Mutual Capacitance

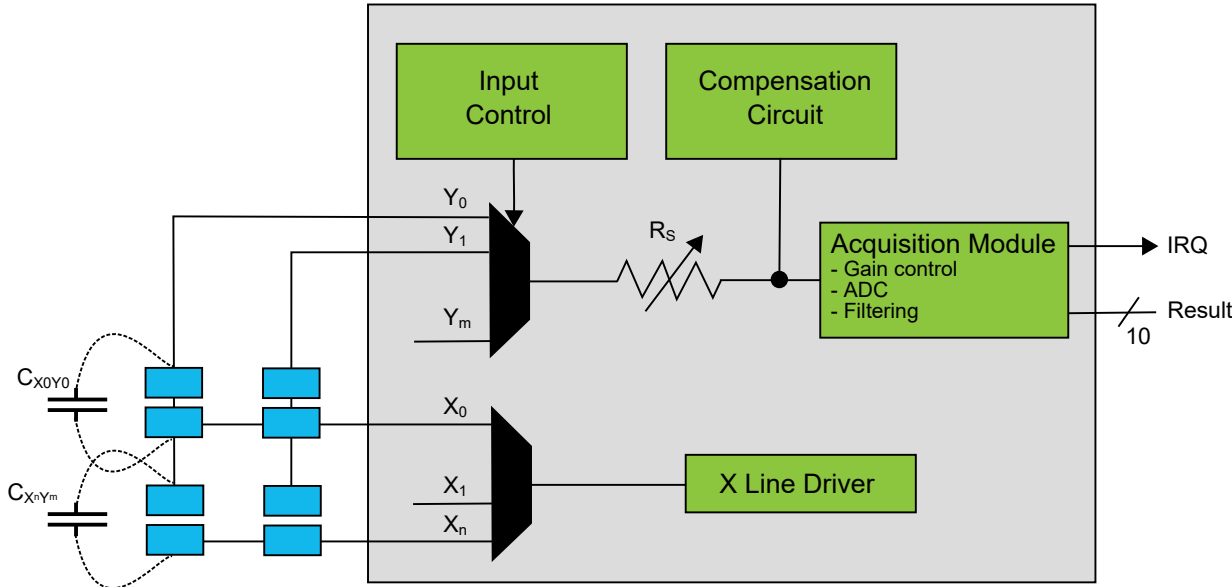
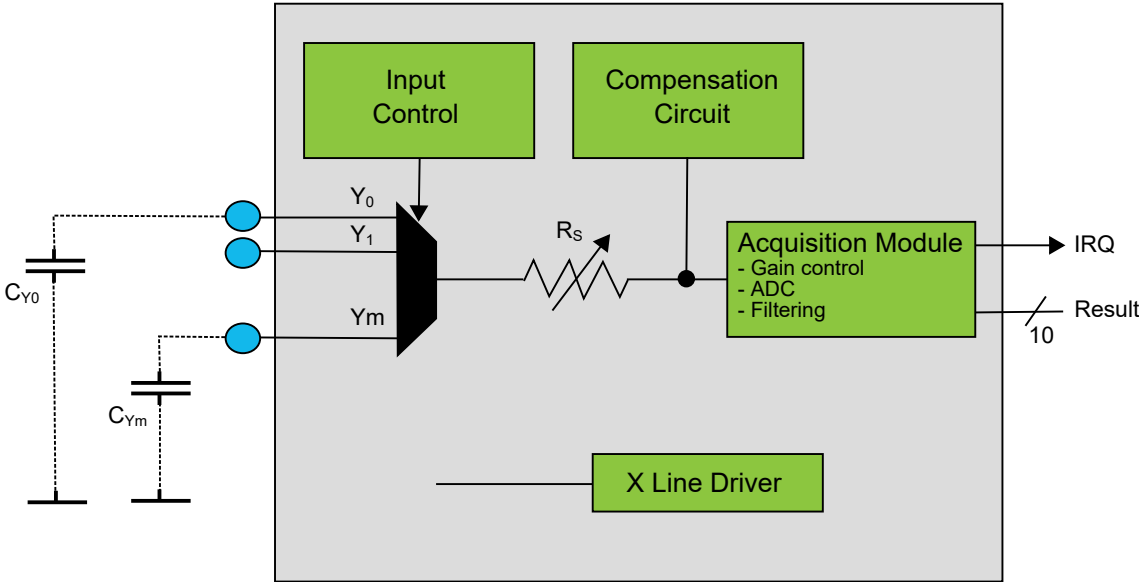
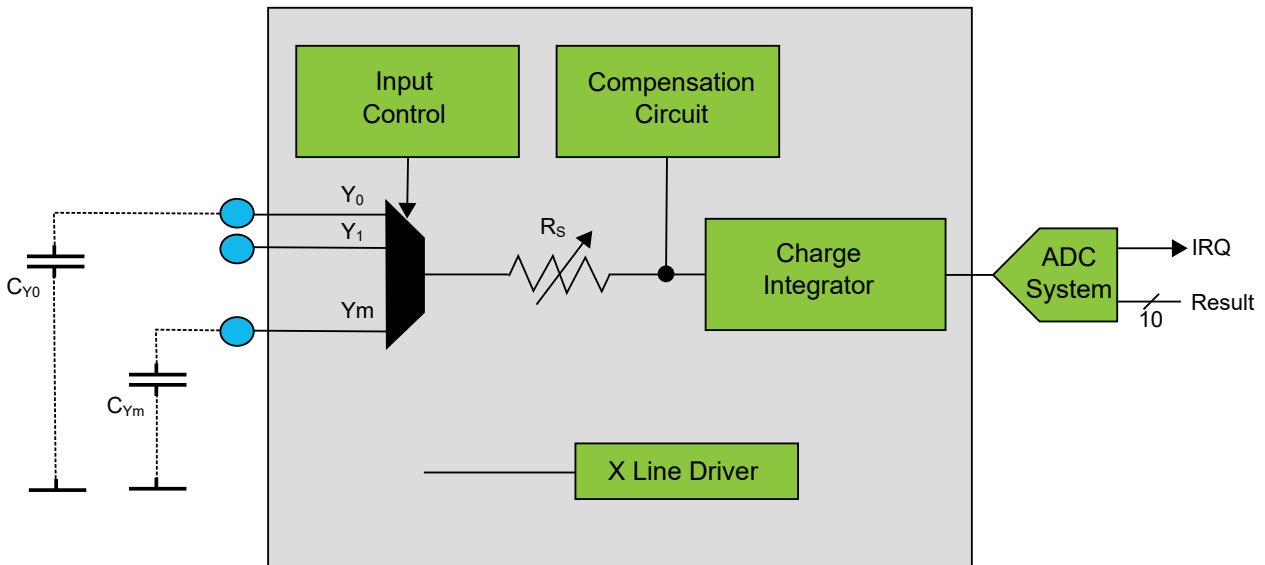


Figure 54-2. PTC Block Diagram Self Capacitance





## 54.4 Signal Description

**Table 54-1.** Signal Description for PTC

Name	Type	Description
Y[m:0]	Analog	Y-line (Input/Output)
X[n:0]	Digital	X-line (Output)

**Note:** The number of X- and Y-lines are device dependent. Refer to [Configuration Summary](#) for details.

Refer to the [Pinout](#) for details on the pin mapping for this peripheral. One signal can be mapped on several pins.

## 54.5 System Dependencies

In order to use this peripheral, configure the other components of the system as described in the following sections.

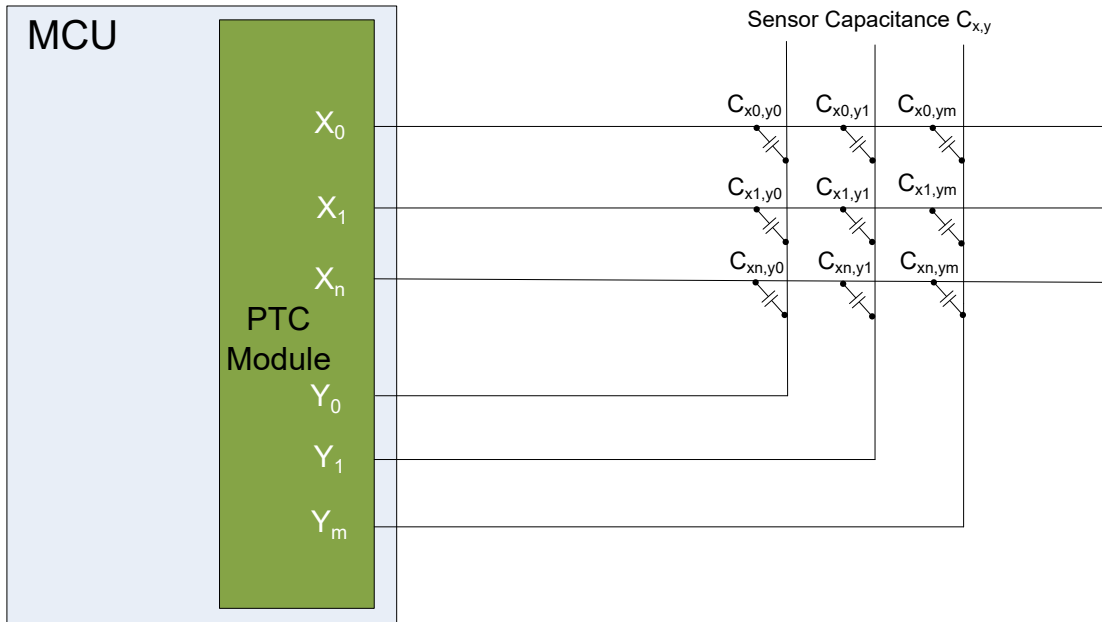
### 54.5.1 I/O Lines

The I/O lines used for analog X- and Y-lines must be connected to external capacitive touch sensor electrodes. External components are not required for normal operation. However, to improve the EMC performance, a series resistor of 1 kΩ or more can be used on X- and Y-lines.

#### 54.5.1.1 Mutual Capacitance Sensor Arrangement

A mutual capacitance sensor is formed between two I/O lines - an X electrode for transmitting and Y electrode for sensing. The mutual capacitance between the X and Y electrode is measured by the peripheral touch controller.

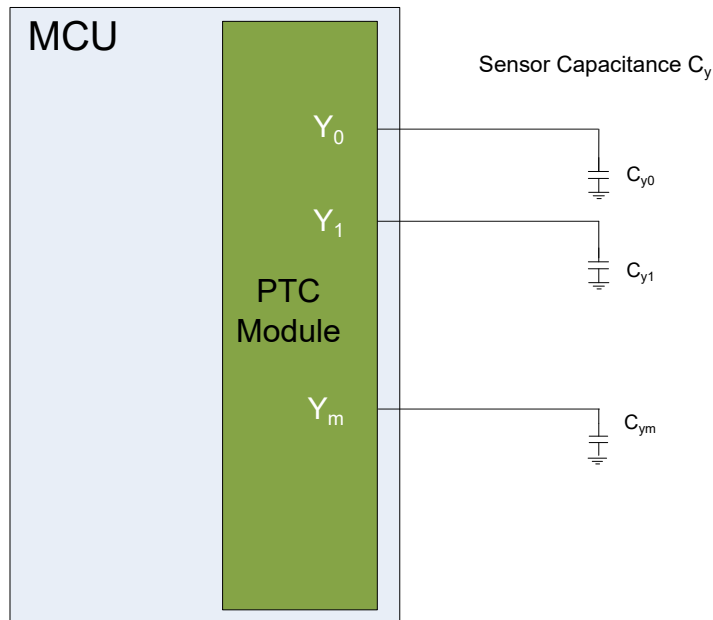
Figure 54-3. Mutual Capacitance Sensor Arrangement



#### 54.5.1.2 Self Capacitance Sensor Arrangement

A self capacitance sensor is connected to a single pin on the peripheral touch controller through the Y electrode for sensing the signal. The sense electrode capacitance is measured by the peripheral touch controller.

Figure 54-4. Self-Capacitance Sensor Arrangement



For more information about designing the touch sensor, refer to [Buttons, Sliders and Wheels Touch Sensor Design Guide](#).

### 54.5.2 Analog-Digital Converter (ADC)

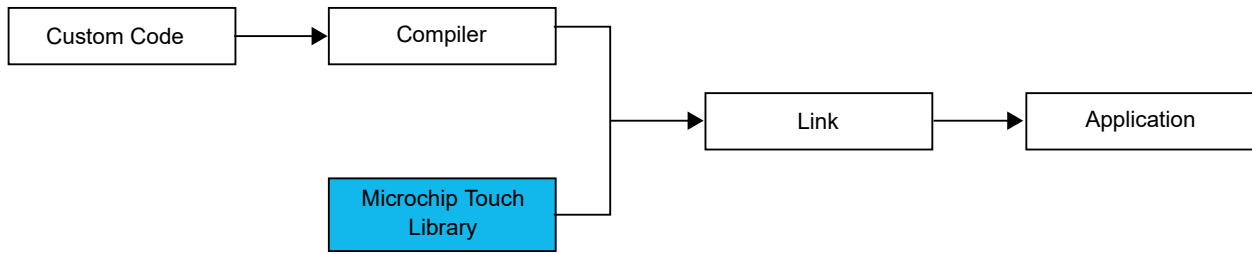
The PTC is using the ADC for signal conversion and acquisition. The [ADC](#) must be enabled and configured appropriately to allow correct behavior of the PTC.

## 54.6 Functional Description

In order to access the PTC, the user must use MPLAB Harmony 3 Touch Library: [github.com/Microchip-MPLAB-Harmony/touch](https://github.com/Microchip-MPLAB-Harmony/touch).

MPLAB Harmony 3 Touch Library can be used to implement buttons, sliders, and wheels in a variety of combinations on a single interface.

**Figure 54-5.** Microchip Touch Library Usage



For more information about QTouch Library, refer to the *Touch Library Peripheral Touch Controller User Guide* on Microchip web site.

## 55. Electrical Specifications 85°C

### 55.1 Disclaimer

Unless otherwise specified:

- Typical data are measured at  $T_A = 25^\circ\text{C}$ . They are for design guidance only and are not tested.
- All minimum and maximum values are valid across operating temperature and voltage.

### 55.2 Absolute Maximum Ratings

Absolute maximum ratings are listed below. Exposure to these maximum rating conditions for extended periods may affect device reliability. Functional operation of the device at these or any other conditions, above the parameters indicated in the operation listings of this specification, is not implied.

**Table 55-1.** Absolute Maximum Electrical Characteristics

<b>Absolute Maximum Ratings</b> <sup>(1)</sup>	
Ambient temperature under bias	-40°C to +125°C
Storage temperature	-60°C to +150°C
Voltage on VDD/AVDD with respect to VSS/AVSS	-0.3V to +3.8V
Voltage on any pins, with respect to VSS/AVSS	-0.3V to (VDD+0.3V) -0.3V to (AVDD+0.3V)
Voltage on VBAT with respect to VSS	-0.3V to +3.6V
Maximum current out of VSS/AVSS pins	826 mA
Maximum current into VDD pins <sup>(2)</sup>	820 mA
Maximum output current sourced/sunk by any Low Current Mode I/O pin	20 mA
Maximum output current sourced/sunk by any High Current Mode I/O pin	20 mA
Maximum current sunk by all ports	696 mA
Maximum current sourced by all ports <sup>(2)</sup>	690 mA
Maximum Junction Temperature	+145°C
<b>ESD qualification:</b>	
Human Body Model (HBM) per JESD22-A114	2000V
Charged Device Model (CDM) (ANSI/ESD STM 5.3.1) (All pins / Corner pins)	500V/750V
<b>Notes:</b>	
1. Stresses above those listed under "Absolute Maximum Ratings" may cause permanent damage to the device. This is a stress rating only and functional operation of the device at those or any other conditions, above those indicated in the operation listings of this specification, is not implied. Exposure to maximum rating conditions for extended periods may affect device reliability.	
2. Maximum allowable current is a function of device maximum power dissipation, refer to the <a href="#">Thermal Operating Conditions</a> .	

## 55.3 General Operating Ratings and Thermal Conditions

**Table 55-2.** Operating Frequency versus Voltage (PIC32CX SG41)

Param. No.	VDD, AVDD Range	Temp. Range (in °C)	Max CPU Frequency	Comments
DC_5	1.71 to 3.63V	-40°C to +85°C	120 MHz	Industrial

**Note:** The same voltage must be applied to VDD and AVDD.

**Table 55-3.** Operating Frequency versus Voltage (PIC32CX SG60/SG61)

Param. No.	VDD, AVDD Range	Temp. Range (in °C)	Max CPU Frequency	Comments
DC_7	2.7 to 3.63V	-40°C to +85°C	120 MHz	Industrial

**Note:** The same voltage must be applied to VDD and AVDD.

**Table 55-4.** Thermal Operating Conditions

Rating	Symbol	Min.	Typ.	Max.	Unit
Extended Temperature Range: Operating Ambient Temperature Range Operating Junction Temperature Range	$T_A$ $T_J$	-40 ---	—	85 105	°C
<b>Power Dissipation:</b> Internal Chip Power Dissipation: $P_{INT} = VDD \times (IDD - \sum IOH_{VDD}) + AVDD \times (IDDANA - \sum IOH_{AVDD})$ I/O Pin Power Dissipation: $P_{I/O} = \sum ((VDD - VOH) \times IOH_{VDD}) + \sum (VOL \times IOL_{VDD}) + \sum ((AVDD - VOH) \times IOH_{AVDD}) + \sum (VOL \times IOL_{AVDD})$	$P_D$	$P_{INT} + P_{I/O}$			W
Maximum Allowed Power Dissipation	$P_{DMAX}$	$(T_J - T_A)/\theta_{JA}$			W

**Table 55-5.** Thermal Packaging Characteristics (PIC32CX SG41) <sup>(1)</sup>

Characteristics	Symbol	Typ.	Max.	Unit
Thermal Resistance, 64-pin TQFP (10x10x1.0 mm) Package	$\theta_{JA}$	57.4	—	°C/W
Thermal Resistance, 100-pin TQFP (14x14x1.0 mm) Package		41.11	—	
Thermal Resistance, 128-pin TQFP (14x14x1.0 mm) Package		34.45	—	

**Note:**

- Junction to ambient thermal resistance, Theta-JA ( $\theta_{JA}$ ) numbers are achieved by package simulations.

**Table 55-6.** Thermal Packaging Characteristics (PIC32CX SG60/SG61) <sup>(1)</sup>

Characteristics	Symbol	Typ.	Max.	Unit
Thermal Resistance, 100-pin TQFP with exposed pad (14x14x1.0 mm) Package	$\theta_{JA}$	32.67	—	°C/W
Thermal Resistance, 100-pin TFBGA (9x9x1.2 mm) Package		25.76	—	
Thermal Resistance, 128-pin TQFP with exposed pad (14x14x1.0 mm) Package		29.15	—	

**Note:**

- Junction to ambient thermal resistance, Theta-JA ( $\theta_{JA}$ ) numbers are achieved by package simulations.

## 55.4 Power Supply

Table 55-7. Power Supply Electrical Specifications

DC CHARACTERISTICS			Standard Operating Conditions: VDD = AVDD = 1.71V to 3.63V (unless otherwise stated) Operating Temperature: -40°C ≤ T <sub>A</sub> ≤ +85°C for Industrial Temperature				
Param. No.	Symbol	Characteristics	Min.	Typ.	Max.	Units	Conditions
REG_1	VDDCORE_C <sub>IN</sub> <sup>(1)</sup>	VDDCORE Input Bypass parallel Capacitor pair	3.76	4.7	—	μF	Bulk Ceramic or solid Tantalum with ESR <0.5Ω. Min and max represent absolute values including cap tolerances
			80	100	—	nF	Ceramic XR7 with ESR <0.5Ω
REG_5	VDD_C <sub>IN</sub> <sup>(1)</sup>	VDD Input Bypass parallel Capacitor pair	8	10	—	μF	Bulk Ceramic or solid Tantalum with ESR <0.5Ω. Separate BULK capacitor for each VDD
			80	100	—	nF	Ceramic XR7 with ESR <0.5Ω on all VDD pins
REG_9	VREFx_C <sub>IN</sub> <sup>(1)</sup>	External VREFx Input Bypass parallel Capacitor pair	8	10	—	μF	Bulk Ceramic or solid Tantalum with ESR <0.5Ω
			80	100	—	nF	Ceramic XR7 with ESR <0.5Ω
REG_13	VBAT_C <sub>IN</sub> <sup>(1)</sup>	VBAT Input Bypass parallel Capacitor pair	8	10	—	μF	Bulk Ceramic or solid Tantalum with ESR <0.5Ω
			80	100	—	nF	Ceramic XR7 with ESR <0.5Ω
REG_17	AVDD_C <sub>IN</sub> <sup>(1)</sup>	AVDD Input Bypass parallel Capacitor pair	8	10	—	μF	Bulk Ceramic or solid Tantalum with ESR <0.5Ω
			80	100	—	nF	Ceramic XR7 with ESR <0.5Ω
REG_23	AVDD_L <sub>EXT</sub> <sup>(2)</sup>	AVDD series Ferrite Bead DCR (DC Resistance)	—	—	0.1	Ω	≥600Ω @ 100 MHz
REG_25		Ferrite Bead current Rating	500	—	—	mA	—
REG_27	VSW_L <sub>EXT</sub> <sup>(3,4,5)</sup>	Buck Switch Mode Regulator Inductor Inductance (If LDO Mode not used)	—	10	—	μH	Shielded Inductor ONLY (If used in BUCK mode else No Connect)
REG_29		Inductor DCR (DC Resistance)	—	—	0.36	Ω	—
REG_31		Inductor ISAT Rating	500	—	—	mA	—
REG_33	BUCK_P <sub>EFF</sub>	Buck Mode Power Efficiency	—	66	—	%	IOUT = 100 uA
REG_35			—	74	—	%	IOUT = 100 mA
REG_36	VDDCORE	VDDCORE Voltage Range	—	1.2	—	V	CPU Active, cache and prefetch disabled, executing "while(1)" from Flash
REG_37	VDD	VDD Input Voltage Range	1.71	3.3	3.63	V	BOD33 Disabled
REG_37A	IDD <sub>VDD_MAX</sub>	VDD/AVDD Max Current	—	—	130	mA	I/O pins configured as inputs
REG_39	AVDD	AVDD Input Voltage Range	1.71	3.3	3.63	V	BOD33 Disabled
REG_41	VBAT	VBAT Input Voltage Range	1.71	—	3.63	V	BOD33 Disabled
REG_41A	IDD <sub>VBAT_MAX</sub>	VBAT Max Current	—	—	315	μA	OSCULP32K, BOD and RTC enabled
REG_43	SVDD_R	VDD, AVDD Rise Ramp Rate to Ensure Internal Power-on Reset Signal	0.2	—	100	mV/μs	Failure to meet this specification may lead to start-up or unexpected behaviors

.....continued

DC CHARACTERISTICS			Standard Operating Conditions: VDD = AVDD = 1.71V to 3.63V (unless otherwise stated) Operating Temperature: -40°C ≤ T <sub>A</sub> ≤ +85°C for Industrial Temperature				
Param. No.	Symbol	Characteristics	Min.	Typ.	Max.	Units	Conditions
REG_44	SVDD_F	VDD, AVDD Falling Ramp Rate to Ensure Internal Power-on Reset Signal	—	—	50	mV/μs	Failure to meet this specification may cause the device to not detect reset
REG_45	VPOR	Power-on Reset	0.97	—	1.64	V	VDD Power up/Down (See Param REG_43, VDD Ramp Rate)
REG_47	VBOD33 <sup>(6,7)</sup>	VDD BOD (All modes)	1.46	—	1.56	V	SUPC.BOD33.LEVEL[7:0] = 0x00 (Min Value) , SUPC.BOD33.HYST[3:0] = 0x02
			1.61	—	1.71		SUPC.BOD33.LEVEL[7:0] = 0x19 (Recommended Value) , SUPC.BOD33.HYST[3:0] = 0x02
			1.63	—	1.73		SUPC.BOD33.LEVEL[7:0] = 0x1C (Recommended Value) , SUPC.BOD33.HYST[3:0] = 0x02
			2.95	—	3.12		SUPC.BOD33.LEVEL[7:0] = 0xFF (Max Value) , SUPC.BOD33.HYST[3:0] = 0x00
REG_51	VBOD33 <sub>LEVEL_STEP</sub>	VBOD33 step size (SUPC.BOD33.LEVEL)	—	6	—	mV	Step Size
REG_52	VBOD33 <sub>HYST_STEP</sub>	VBOD33 Hysteresis step size (SUPC.BOD33.HYST)	—	6	—	mV	Step Size
REG_53	T <sub>RST</sub>	External RESET valid active pulse width	1	—	—	μs	Minimum reset active time to guarantee CPU reset



.....continued

DC CHARACTERISTICS			Standard Operating Conditions: VDD = AVDD = 1.71V to 3.63V (unless otherwise stated) Operating Temperature: -40°C ≤ T <sub>A</sub> ≤ +85°C for Industrial Temperature				
--------------------	--	--	---	--	--	--	--

Param. No.	Symbol	Characteristics	Min.	Typ.	Max.	Units	Conditions
------------	--------	-----------------	------	------	------	-------	------------

**Notes:**

- All bypass caps should be located immediately adjacent to pin(s) and on the same side of the PCB as the MCU. Each primary power supply group VDD, AVDD, VDDCORE and VBAT should have one bulk capacitor and on all power pins everywhere a 100nF bypass cap.
- Ferrite Bead ISAT(min) ≥ (IDDANA(max) \* 1.15).
- User must select either LDO or BUCK Mode. The modes are mutually exclusive.
- Buck Inductor ISAT(min) ≥ ((ICAPACITOR + IVDD<sub>CORE\_MAX</sub>) \* 1.25) when BUCK mode enabled (shielded inductor only).
- Given:  
 BUCK VSW output pin impedance = ~4 ohms  
 Buck Inductor DCR = ~0.2 ohms (Check Inductor Mfg spec)  
 C= VDDCORE Bypass Capacitance  
 RVSW = VSW output pin impedance + Buck Inductor DCR  
 e = 2.71828  
 Recommended Inductor ISAT margin 25%  
 VDDCORE bypass bulk capacitor charging current through inductor:  
 ICAPACITOR = (VDDCORE / RVSW) e-t/RC where t=0 is worst case  
**THEREFORE:**  
 Inductor ISAT(max) = ((ICAPACITOR + IVDDCORE\_PEAK\_SURGE) \* 1.25) = (((VDDCORE / RVSW) e-t/RC + IVDDCORE\_PEAK\_SURGE) \* 1.25)  
**Example:**
  - VDDCORE bypass capacitors = 4.7µF + 100nF
  - IVDDCORE\_PEAK\_SURGE = 120mA
 Inductor ISAT(max) = (((VDDCORE / RVSW) e-t/RC + IVDDCORE\_PEAK\_SURGE) \* 1.25)  
 = (((1.2 / 4.2) \* 2.71828-(0 / 4.3\*4.8µF) + 120mA) \* 1.25)  
 = (((286mA \* 1) + 120mA) \* 1.25)  
 = ((286mA + 120mA) \* 1.25)  
 = ~508mA
- VBOD(min) = (1.5 + (SUPC.BOD33.LEVEL[7:0] \* VBOD33<sub>LEVEL\_STEP</sub>))  
 VBOD(max) = (VBOD(min) + (SUPC.BOD33.HYST[3:0] \* VBOD33<sub>HYST\_STEP</sub>))
- If a hysteresis value is programmed, the following equation must be respected to avoid any overflow on VBOD(max) : LEVEL[7:0] value ≤ 255 - HYST[3:0] value.

## 55.5 MCU Active Current Consumption

**Table 55-8.** MCU Active Current Consumption Electrical Specifications <sup>(1,2,3)</sup>

DC CHARACTERISTICS				Standard Operating Conditions: VDD = AVDD = 1.71V to 3.63V (unless otherwise stated) Operating temperature: -40°C ≤ T <sub>A</sub> ≤ +85°C for Industrial Temperature			
Param. No.	Symbol	Characteristics	Clock/Freq	Typ.	Max.	Units	Conditions
APWR_1	I <sub>DD_ACTIVE</sub>	LDO mode selected	FDPLL 120 MHz	----	164	μA/MHz	VDD = 3.3V XOSC32K = 32 kHz crystal with XOSC32K.CGM = 1
APWR_3				----	162	μA/MHz	VDD = 1.8V XOSC32K = 32 kHz crystal with XOSC32K.CGM = 1
APWR_5			DFLL 48 MHz	----	199	μA/MHz	VDD = 3.3V XOSC32K = 32 kHz crystal with XOSC32K.CGM = 1
APWR_7				----	199	μA/MHz	VDD = 1.8V XOSC32K = 32 kHz crystal with XOSC32K.CGM = 1
APWR_9			XOSC 32 MHz	----	245	μA/MHz	VDD = 3.3V XOSC32K.ENABLE = 0
APWR_11				----	243	μA/MHz	VDD = 1.8V XOSC32K.ENABLE = 0
APWR_13	I <sub>DD_ACTIVE</sub>	BUCK mode selected	FDPLL 120 MHz	----	89	μA/MHz	VDD = 3.3V XOSC32K = 32 kHz crystal with XOSC32K.CGM = 1
APWR_15				----	127	μA/MHz	VDD = 1.8V XOSC32K = 32 kHz crystal with XOSC32K.CGM = 1
APWR_17			DFLL 48 MHz	----	115	μA/MHz	VDD = 3.3V XOSC32K = 32 kHz crystal with XOSC32K.CGM = 1
APWR_19				----	152	μA/MHz	VDD = 1.8V XOSC32K = 32 kHz crystal with XOSC32K.CGM = 1
APWR_21			XOSC 32 MHz	----	153	μA/MHz	VDD = 3.3V XOSC32K.ENABLE = 0
APWR_23				----	205	μA/MHz	VDD = 1.8V XOSC32K.ENABLE = 0

.....continued

DC CHARACTERISTICS				Standard Operating Conditions: VDD = AVDD = 1.71V to 3.63V (unless otherwise stated) Operating temperature: -40°C ≤ T <sub>A</sub> ≤ +85°C for Industrial Temperature			
Param. No.	Symbol	Characteristics	Clock/Freq	Typ.	Max.	Units	Conditions
<b>Notes:</b>							
1. Conditions:							
<ul style="list-style-type: none"> <li>- No peripheral modules are operating (i.e. all peripherals inactive)</li> <li>- MCLK all APB clock masked except MCLK and NVMCTRL</li> <li>- MCLK.AHBMASK = 0x00C00FFF</li> <li>- CMCC Enable</li> <li>- CPU is running on Flash with automatic wait state</li> <li>- Low-power cache enabled</li> <li>- BOD33 is disabled</li> <li>- I/Os are inactive input mode with input trigger disabled</li> <li>- All clock generation sources disabled unless otherwise specified</li> <li>- WDT, RTC, CFD Clock Fail Detect disabled</li> <li>- RESET = VDD</li> </ul>							
<p><b>Note:</b> μA/MHz varies over temperature. Worst case is given by max.</p>							
2. CPU Running CoreMark® Test Suite.							
3. For the PIC32CX SG60/SG61 variants, the current consumption of the HSM is not taken into account and must be added according to its operating mode. Refer to the "PIC32CX SG60/SG61 Hardware Security Module Addendum (DS60001750)" for additional information.							

## 55.6 MCU Idle Current Consumption

**Table 55-9.** MCU Idle Current Consumption Electrical Specifications <sup>(1,2)</sup>

DC CHARACTERISTICS				Standard Operating Conditions: VDD = AVDD = 1.71V to 3.63V (unless otherwise stated) Operating temperature: -40°C ≤ T <sub>A</sub> ≤ +85°C for Industrial Temperature			
Param. No.	Symbol	Characteristics	Clock/Freq	Typ.	Max.	Units	Conditions
IPWR_1	I <sub>DD_IDLE</sub>	LDO mode selected	FDPLL 120 MHz	----	48	μA/MHz	VDD = 3.3V XOSC32K = 32 kHz crystal with XOSC32K.CGM = 1
IPWR_3				----	46	μA/MHz	VDD = 1.8V XOSC32K = 32 kHz crystal with XOSC32K.CGM = 1
IPWR_5			DFLL 48 MHz	----	81	μA/MHz	VDD = 3.3V XOSC32K = 32 kHz crystal with XOSC32K.CGM = 1
IPWR_7				----	84	μA/MHz	VDD = 1.8V XOSC32K = 32 kHz crystal with XOSC32K.CGM = 1
IPWR_9			XOSC 32 MHz	----	117	μA/MHz	VDD = 3.3V XOSC32K.ENABLE = 0
IPWR_11				----	117	μA/MHz	VDD = 1.8V XOSC32K.ENABLE = 0

.....continued

DC CHARACTERISTICS				Standard Operating Conditions: VDD = AVDD = 1.71V to 3.63V (unless otherwise stated) Operating temperature: -40°C ≤ T <sub>A</sub> ≤ +85°C for Industrial Temperature			
Param. No.	Symbol	Characteristics	Clock/Freq	Typ.	Max.	Units	Conditions
IPWR_13	I <sub>DD_IDLE</sub>	BUCK mode selected	FDPLL 120 MHz	----	28	μA/MHz	VDD = 3.3V XOSC32K = 32 kHz crystal with XOSC32K.CGM = 1
IPWR_15				----	35	μA/MHz	VDD = 1.8V XOSC32K = 32 kHz crystal with XOSC32K.CGM = 1
IPWR_17			DFLL 48 MHz	----	46	μA/MHz	VDD = 3.3V XOSC32K = 32 kHz crystal with XOSC32K.CGM = 1
IPWR_19				----	63	μA/MHz	VDD = 1.8V XOSC32K = 32 kHz crystal with XOSC32K.CGM = 1
IPWR_21			XOSC 32 MHz	----	71	μA/MHz	VDD = 3.3V XOSC32K.ENABLE = 0
IPWR_23				----	90	μA/MHz	VDD = 1.8V XOSC32K.ENABLE = 0

**Notes:**

1. Conditions:

- No peripheral modules are operating (i.e. all peripherals inactive)
- MCLK all APB clock masked except MCLK and NVMCTRL
- MCLK.AHBMASK = 0x00C00FFF
- CMCC Enable
- CPU is running on Flash with automatic wait state
- Low-power cache enabled
- BOD33 is disabled
- I/Os are inactive input mode with input trigger disabled
- All clock generation sources disabled unless otherwise specified
- WDT, RTC, CFD Clock Fail Detect disabled
- $\overline{\text{RESET}} = \text{VDD}$

**Note:** μA/MHz varies over temperature. Worst case is given by max.

2. For the PIC32CX SG60/SG61 variants, the current consumption of the HSM is not taken into account and must be added according to its operating mode. Refer to the "PIC32CX SG60/SG61 Hardware Security Module Addendum (DS60001750)" for additional information.

## 55.7 MCU Standby Current Consumption

**Table 55-10.** MCU Standby Current Consumption Electrical Specifications <sup>(1,2)</sup>

DC CHARACTERISTICS				Standard Operating Conditions: VDD = AVDD = 1.71V to 3.63V (unless otherwise stated) Operating temperature: -40°C ≤ T <sub>A</sub> ≤ +85°C for Industrial Temperature			
Param. No.	Symbol	Characteristics	VDD	Typ.	Max.	Units	Conditions
SPWR_1	I <sub>DD_STANDBY</sub>	LDO mode selected	3.3V	----	869	μA	Fast wake-up disabled (PM.STDBYCFG.FASTWKUP = 0x0), No System RAM retained (PM.STDBYCFG.RAMCFG = 0x2), 8 KB backup RAM retained (PM.BKUPCFG.BRAMCFG = 0x0)
SPWR_3			1.8V	----	869	μA	
SPWR_5			3.3V	----	1392	μA	Fast wake-up enabled (PM.STDBYCFG.FASTWKUP = 0x3), No System RAM retained (PM.STDBYCFG.RAMCFG = 0x2), 8 KB backup RAM retained (PM.BKUPCFG.BRAMCFG = 0x0)
SPWR_7			1.8V	----	1388	μA	
SPWR_9			3.3V	----	870	μA	Fast wake-up disabled (PM.STDBYCFG.FASTWKUP = 0x0), RTC running on XOSC32K No System RAM retained (PM.STDBYCFG.RAMCFG=0x2). 8 KB backup RAM retained (PM.BKUPCFG.BRAMCFG = 0x0)
SPWR_11			1.8V	----	870	μA	
SPWR_13			3.3V	----	911	μA	Fast wake-up disabled (PM.STDBYCFG.FASTWKUP = 0x0), RTC running on XOSC32K 32 KB System RAM retained (PM.STDBYCFG.RAMCFG = 0x1). 8 KB backup RAM retained (PM.BKUPCFG.BRAMCFG = 0x0)

.....continued

DC CHARACTERISTICS				Standard Operating Conditions: VDD = AVDD = 1.71V to 3.63V (unless otherwise stated) Operating temperature: -40°C ≤ T <sub>A</sub> ≤ +85°C for Industrial Temperature			
Param. No.	Symbol	Characteristics	VDD	Typ.	Max.	Units	Conditions
SPWR_15	I <sub>DD_STANDBY</sub>	LDO mode selected	1.8V	----	912	μA	Fast wake-up disabled (PM.STDBYCFG.FASTWKUP = 0x0), RTC running on XOSC32K 32 KB System RAM retained (PM.STDBYCFG.RAMCFG = 0x1). 8 KB backup RAM retained (PM.BKUPCFG.BRAMCFG = 0x0)
SPWR_17			3.3V	----	1067	μA	Fast wake-up disabled (PM.STDBYCFG.FASTWKUP = 0x0), RTC running on XOSC32K
SPWR_19			1.8V	----	1068	μA	Full System RAM retained (PM.STDBYCFG.RAMCFG = 0x0). 8 KB backup RAM retained (PM.BKUPCFG.BRAMCFG = 0x0)
SPWR_21			3.3V	----	1722	μA	Fast wake-up enabled (PM.STDBYCFG.FASTWKUP = 0x3), Full System RAM retained (PM.STDBYCFG.RAMCFG = 0x0), No backup RAM retained (PM.BKUPCFG.BRAMCFG = 0x2)
SPWR_23			1.8V	----	1716	μA	fast wake-up enabled (PM.STDBYCFG.FASTWKUP = 0x3), RTC running on XOSC32K
SPWR_25			3.3V	----	1732	μA	Full System RAM retained (PM.STDBYCFG.RAMCFG = 0x0). No backup RAM retained (PM.BKUPCFG.BRAMCFG = 0x2)
SPWR_27			1.8V	----	1724	μA	

.....continued

DC CHARACTERISTICS				Standard Operating Conditions: VDD = AVDD = 1.71V to 3.63V (unless otherwise stated) Operating temperature: -40°C ≤ T <sub>A</sub> ≤ +85°C for Industrial Temperature				
Param. No.	Symbol	Characteristics	VDD	Typ.	Max.	Units	Conditions	
SPWR_29	I <sub>DD_STANDBY</sub>	BUCK mode selected	3.3V	----	440	μA	Fast wake-up disabled (PM.STDBYCFG.FASTWKUP = 0x0), No System RAM retained (PM.STDBYCFG.RAMCFG = 0x2), 8 KB backup RAM retained (PM.BKUPCFG.BRAMCFG = 0x0)	
SPWR_31			1.8V	----	570	μA		
SPWR_33			3.3V	----	738	μA		
SPWR_35			1.8V	----	1047	μA		
SPWR_37			3.3V	----	443	μA		
SPWR_39			1.8V	----	571	μA		Fast wake-up disabled (PM.STDBYCFG.FASTWKUP = 0x0), RTC running on XOSC32K No System RAM retained (PM.STDBYCFG.RAMCFG = 0x2). 8 KB backup RAM retained (PM.BKUPCFG.BRAMCFG = 0x0)
SPWR_41			3.3V	----	462	μA		Fast wake-up disabled (PM.STDBYCFG.FASTWKUP = 0x0), RTC running on XOSC32K 32 KB System RAM retained (PM.STDBYCFG.RAMCFG = 0x1). 8 KB backup RAM retained (PM.BKUPCFG.BRAMCFG = 0x0)

.....continued

DC CHARACTERISTICS				Standard Operating Conditions: VDD = AVDD = 1.71V to 3.63V (unless otherwise stated) Operating temperature: -40°C ≤ T <sub>A</sub> ≤ +85°C for Industrial Temperature			
Param. No.	Symbol	Characteristics	VDD	Typ.	Max.	Units	Conditions
SPWR_43	I <sub>DD_STANDBY</sub>	BUCK mode selected	1.8V	----	598	μA	Fast wake-up disabled (PM.STDBYCFG.FASTWKUP = 0x0), RTC running on XOSC32K 32 KB System RAM retained (PM.STDBYCFG.RAMCFG = 0x1). 8 KB backup RAM retained (PM.BKUPCFG.BRAMCFG = 0x0)
SPWR_45			3.3V	----	537	μA	Fast wake-up disabled (PM.STDBYCFG.FASTWKUP = 0x0), RTC running on XOSC32K
SPWR_47			1.8V	----	702	μA	Full System RAM retained (PM.STDBYCFG.RAMCFG = 0x0). 8 KB backup RAM retained (PM.BKUPCFG.BRAMCFG = 0x0)
SPWR_49			3.3V	----	911	μA	Fast wake-up enabled (PM.STDBYCFG.FASTWKUP = 0x3), Full System RAM retained (PM.STDBYCFG.RAMCFG = 0x0), No backup RAM retained (PM.BKUPCFG.BRAMCFG = 0x2)
SPWR_51			1.8V	----	1298	μA	Fast wake-up enabled (PM.STDBYCFG.FASTWKUP = 0x3), RTC running on XOSC32K
SPWR_53			3.3V	----	915	μA	Full System RAM retained (PM.STDBYCFG.RAMCFG = 0x0). No backup RAM retained (PM.BKUPCFG.BRAMCFG = 0x2)
SPWR_55			1.8V	----	1305	μA	

**Notes:**

- Conditions
  - No peripheral modules are operating (i.e. all peripherals inactive)
  - MCLK all APB clock masked except MCLK and NVMCTRL
  - MCLK.AHBMASK = 0x00C00FFF
  - BOD33 is disabled
  - I/Os are inactive input mode with input trigger disabled
  - All clock generation sources disabled unless otherwise specified
  - WDT, CFD Clock Fail Detect disabled
  - RESET = VDD
- For the PIC32CX SG60/SG61 variants, the current consumption of the HSM is not taken into account and must be added according to its operating mode. Refer to the "PIC32CX SG60/SG61 Hardware Security Module Addendum (DS60001750)" for additional information.



## 55.8 MCU Hibernate Current Consumption

**Table 55-11.** MCU Hibernate Current Consumption Electrical Specifications <sup>(1,2)</sup>

DC CHARACTERISTICS				Standard Operating Conditions: VDD = AVDD = 1.71V to 3.63V (unless otherwise stated) Operating temperature: -40°C ≤ T <sub>A</sub> ≤ +85°C for Industrial Temperature			
Param. No.	Symbol	Characteristics	VDD	Typ.	Max.	Units	Conditions
HPWR_1	I <sub>DD_HIBERNATE</sub>	LDO mode selected	3.3V	----	48	μA	No peripheral running. No System RAM retained (PM.HIBCFG.RAMCFG=0x2)
HPWR_3			1.8V	----	47	μA	No backup RAM retained (PM.HIBCFG.BRAMCFG=0x2)
HPWR_5			3.3V	----	49	μA	RTC is running on XOSC32K No System RAM retained (PM.HIBCFG.RAMCFG=0x2)
HPWR_7			1.8V	----	48	μA	No backup RAM retained (PM.HIBCFG.BRAMCFG=0x2)
HPWR_9			3.3V	----	56	μA	RTC is running on XOSC32K No System RAM retained (PM.HIBCFG.RAMCFG=0x2)
HPWR_11			1.8V	----	55	μA	4 KB backup RAM retained (PM.HIBCFG.BRAMCFG=0x1)
HPWR_13			3.3V	----	63	μA	RTC is running on XOSC32K No System RAM retained (PM.HIBCFG.RAMCFG=0x2)
HPWR_15			1.8V	----	61	μA	8 KB backup RAM retained (PM.HIBCFG.BRAMCFG=0x0)
HPWR_17			3.3V	----	101	μA	RTC is running on XOSC32K 32 KB System RAM retained (PM.HIBCFG.RAMCFG=0x1)
HPWR_19			1.8V	----	100	μA	8 KB backup RAM retained (PM.HIBCFG.BRAMCFG=0x0)
HPWR_21			3.3V	----	255	μA	RTC is running on XOSC32K Full System RAM retained (PM.HIBCFG.RAMCFG=0x0)
HPWR_23			1.8V	----	255	μA	8 KB backup RAM retained (PM.HIBCFG.BRAMCFG=0x0)

.....continued

DC CHARACTERISTICS				Standard Operating Conditions: VDD = AVDD = 1.71V to 3.63V (unless otherwise stated) Operating temperature: -40°C ≤ T <sub>A</sub> ≤ +85°C for Industrial Temperature			
Param. No.	Symbol	Characteristics	VDD	Typ.	Max.	Units	Conditions
HPWR_25	I <sub>DD_HIBERNATE</sub>	BUCK mode selected	3.3V	----	29	μA	No peripheral running. No System RAM retained (PM.HIBCFG.RAMCFG=0x2)
HPWR_27			1.8V	----	29	μA	No backup RAM retained (PM.HIBCFG.BRAMCFG=0x2)
HPWR_29			3.3V	----	30	μA	RTC is running on XOSC32K No System RAM retained (PM.HIBCFG.RAMCFG=0x2)
HPWR_31			1.8V	----	30	μA	No backup RAM retained (PM.HIBCFG.BRAMCFG=0x2)
HPWR_33			3.3V	----	33	μA	RTC is running on XOSC32K No System RAM retained (PM.HIBCFG.RAMCFG=0x2)
HPWR_35			1.8V	----	35	μA	4 KB backup RAM retained (PM.HIBCFG.BRAMCFG=0x1)
HPWR_37			3.3V	----	31	μA	RTC is running on XOSC32K No System RAM retained (PM.HIBCFG.RAMCFG=0x2)
HPWR_39			1.8V	----	39	μA	8 KB backup RAM retained (PM.HIBCFG.BRAMCFG=0x0)
HPWR_41			3.3V	----	48	μA	RTC is running on XOSC32K 32 KB System RAM retained (PM.HIBCFG.RAMCFG=0x1)
HPWR_43			1.8V	----	65	μA	8 KB backup RAM retained (PM.HIBCFG.BRAMCFG=0x0)
HPWR_45			3.3V	----	121	μA	RTC is running on XOSC32K Full System RAM retained (PM.HIBCFG.RAMCFG=0x0)
HPWR_47			1.8V	----	166	μA	8 KB backup RAM retained (PM.HIBCFG.BRAMCFG=0x0)

**Notes:**

- Conditions:
  - No peripheral modules are operating (i.e. all peripherals inactive)
  - MCLK all APB clock masked except MCLK and NVMCTRL
  - MCLK.AHBMASK = 0x00C00FFF
  - BOD33 is disabled
  - I/Os are inactive input mode with input trigger disabled
  - All clock generation sources disabled unless otherwise specified
  - WDT, CFD Clock Fail Detect disabled
  - $\overline{\text{RESET}} = \text{VDD}$
- For the PIC32CX SG60/SG61 variants, the current consumption of the HSM is not taken into account and must be added according to its operating mode. Refer to the "PIC32CX SG60/SG61 Hardware Security Module Addendum (DS60001750)" for additional information.

## 55.9 MCU Backup Current Consumption

**Table 55-12.** MCU Backup Current Consumption Electrical Specifications <sup>(1,2)</sup>

DC CHARACTERISTICS				Standard Operating Conditions: VDD = AVDD = 1.71V to 3.63V (unless otherwise stated) Operating temperature: -40°C ≤ T <sub>A</sub> ≤ +85°C for Industrial Temperature			
Param. No.	Symbol	Characteristics	VDD or VBAT	Min.	Max.	Units	Conditions
BPWR_1	I <sub>DD_BACKUP</sub>	Backup powered from VDD	VDD = 3.3V	---	42.5	μA	No RTC, No XOSC32 running
BPWR_3			VDD = 1.8V	---	41.7	μA	No backup RAM retained (PM.BKUPCFG.BRAMCFG=0x2) BOD33 disabled
BPWR_5			VDD = 3.3V	---	43.6	μA	RTC running on XOSC32K No backup RAM retained
BPWR_7			VDD = 1.8V	---	42.6	μA	(PM.BKUPCFG.BRAMCFG=0x2) BOD33 disabled
BPWR_9			VDD = 3.3V	---	49.1	μA	No RTC running, No XOSC32 running
BPWR_11			VDD = 1.8V	---	48.4	μA	4 KB backup RAM retained (PM.BKUPCFG.BRAMCFG = 0x1) BOD33 disabled
BPWR_13			VDD = 3.3V	---	55.8	μA	No RTC , No XOSC32
BPWR_15			VDD = 1.8V	---	55.1	μA	8 KB backup RAM retained (PM.BKUPCFG.BRAMCFG=0x0) BOD33 disabled
BPWR_17	I <sub>DD_BACKUP</sub>	Backup powered from VBAT	VBAT=3.3V	---	69.2	μA	No RTC, No XOSC32 running
BPWR_19			VBAT(min)	---	68.3	μA	No backup RAM retained (PM.BKUPCFG.BRAMCFG=0x2) BOD33 enabled in sampled mode PSEL prescaler set to 0x7 (div 256)
BPWR_21			VBAT=3.3V	---	70.4	μA	RTC running on XOSC32K No backup RAM retained
BPWR_23			VBAT(min)	---	69.3	μA	(PM.BKUPCFG.BRAMCFG=0x2) BOD33 enabled in sampled mode PSEL prescaler set to 0x7 (div 256)
BPWR_25			VBAT=3.3V	---	77.7	μA	No RTC, No XOSC32 running
BPWR_27			VBAT(min)	---	77.4	μA	4 KB backup RAM retained (PM.BKUPCFG.BRAMCFG=0x1) BOD33 enabled in sampled mode PSEL prescaler set to 0x7 (div 256)
BPWR_29			VBAT=3.3V	---	85	μA	No RTC, No XOSC32 running
BPWR_31			VBAT(min)	---	76.7	μA	8 KB backup RAM retained (PM.BKUPCFG.BRAMCFG=0x0) BOD33 enabled in sampled mode PSEL prescaler set to 0x7 (div 256)

.....continued

DC CHARACTERISTICS				Standard Operating Conditions: VDD = AVDD = 1.71V to 3.63V (unless otherwise stated) Operating temperature: -40°C ≤ T <sub>A</sub> ≤ +85°C for Industrial Temperature			
--------------------	--	--	--	---	--	--	--

Param. No.	Symbol	Characteristics	VDD or VBAT	Min.	Max.	Units	Conditions
------------	--------	-----------------	-------------	------	------	-------	------------

**Notes:**

1. Conditions:
  - No peripheral modules are operating (i.e. all peripherals inactive)
  - MCLK all APB clock masked except MCLK and NVMCTRL
  - MCLK.AHBMASK = 0x00C00FFF
  - BOD33 is disabled unless noted
  - I/Os are inactive input mode with input trigger disabled
  - All clock generation sources disabled unless otherwise specified
  - WDT, CFD Clock Fail Detect disabled
  - $\overline{\text{RESET}} = \text{VDD}$
2. For the PIC32CX SG60/SG61 variants, the current consumption of the HSM is not taken into account and must be added according to its operating mode. Refer to the "PIC32CX SG60/SG61 Hardware Security Module Addendum (DS60001750)" for additional information.

## 55.10 MCU Off Current Consumption

**Table 55-13.** MCU Off Current Consumption Electrical Specifications <sup>(1,2)</sup>

DC CHARACTERISTICS				Standard Operating Conditions: VDD = AVDD = 1.71V to 3.63V (unless otherwise stated) Operating temperature: -40°C ≤ T <sub>A</sub> ≤ +85°C for Industrial Temperature			
Param. No.	Symbol	Characteristics	VDD	Typ.	Max.	Units	Conditions
OPWR_1	I <sub>DD_OFF</sub>	OFF mode powered from VDD	3.3V	---	3.35	μA	In Off mode, the device is entirely powered-off. (SLEEPCFG.SLEEPMODE=OFF), and subsequent execution of the WFI instruction. <b>Note:</b> This mode is left by pulling the RESET pin low, or when a power Reset is done.
OPWR_3			1.8V	---	2.3	μA	

**Notes:**

- Conditions:
  - All peripherals inactive unless otherwise specified.
  - All clock generation sources disabled unless otherwise specified.
  - All I/O pins configured as input pins pulled down or tied to VSS/AVSS.
- For the PIC32CX SG60/SG61 variants, the current consumption of the HSM is not taken into account and must be added according to its operating mode. Refer to the "PIC32CX SG60/SG61 Hardware Security Module Addendum (DS60001750)" for additional information.

## 55.11 Wake-Up Timings Electrical Specifications

**Table 55-14.** Wake-Up Timing from Low Power Modes Electrical Specifications

AC CHARACTERISTICS			Standard Operating Conditions: VDD = AVDD = 1.71V to 3.63V (unless otherwise stated) Operating temperature: -40°C ≤ T <sub>A</sub> ≤ +85°C for Industrial Temperature				
Param. No.	Symbol	Characteristics	Min.	Typ.	Max.	Units	Conditions
WKUP_1	WKUP_IDLE	Wake from IDLE mode	—	230	—	ns	—
WKUP_3	WKUP_STDBY	Wake from STANDBY Mode	—	110	—	μs	Fast Wake-up is disabled (PM.STDBYCFG.FASTWKUP = 0)
WKUP_5			—	92	—	μs	Fast Wake-up is enabled on the NVM (PM.STDBYCFG.FASTWKUP = 1)
WKUP_7			—	25	—	μs	Fast Wake-up is enabled on the Main Voltage Regulator (PM.STDBYCFG.FASTWKUP = 2)
WKUP_9			—	5	—	μs	Fast Wake-up is enabled on both the NVM and Main Voltage Regulator (PM.STDBYCFG.FASTWKUP = 3)
WKUP_11	WKUP_HIBER	Wake from HIBERNATE Mode	—	320	—	μs	—
WKUP_13	WKUP_BCKUP	Wake from BACKUP Mode	—	350	—	μs	—
WKUP_15	WKUP_OFF	Wake from OFF Mode	—	210	—	μs	—

## 55.12 Peripheral Active Current

**Table 55-15.** Peripheral Active Current Electrical Specifications <sup>(1)</sup>

DC CHARACTERISTICS			Standard Operating Conditions: VDD = AVDD = 1.71V to 3.63V (unless otherwise stated) Operating temperature: -40°C ≤ T <sub>A</sub> ≤ +85°C for Industrial Temperature
Param. No.	Symbol	Characteristics	Conditions
<b>MODULES/PERIPHERALS ACTIVE CURRENTS ≤ 5µA</b>			
PAI_1	BOD_IDD_STBY_HIB	BOD Standby low pwr / Hibernate (1 of 3)	Standby with BOD continuous low power mode or Hibernate mode
PAI_3	XOSC32K	32 kHz Crystal Oscillator	-
<b>MODULES/PERIPHERALS ACTIVE CURRENTS ≤ 10µA</b>			
PAI_11	BOD_IDD_STBY_NORM	BOD Standby normal mode (2 of 3)	Standby with BOD continuous normal mode
<b>MODULES/PERIPHERALS ACTIVE CURRENTS ≤ 15µA</b>			
PAI_51	BOD_IDD_ACT_IDLE	BOD Active / Idle (3 of 3)	Active / Idle Mode, Standby Continuous mode
<b>MODULES/PERIPHERALS ACTIVE CURRENTS ≤ 25µA</b>			
PAI_100	AC_VSCALE_IDD	Comparator Voltage Scaler module IDD	-
<b>MODULES/PERIPHERALS ACTIVE CURRENTS ≤ 100µA</b>			
PAI_400	AC_IDD	Analog Comparator IDD	COMPCTRLn.SPEED=0x3, AVDD=3.3V COMPCTRLn.HYSTEN=0, Hysteresis disabled Voltage scaler disabled
<b>MODULES/PERIPHERALS ACTIVE CURRENTS ≤ 350µA</b>			
PAI_900	DAC_IDD (1 of 4)	DAC operating current	DAC Single ended mode, fs = 10 ksp/s, AVDD = 3.3V
<b>MODULES/PERIPHERALS ACTIVE CURRENTS ≤ 450µA</b>			
PAI_950	DAC_IDD (2 of 4)	DAC operating current	DAC Differential mode, fs = 10 ksp/s, AVDD = 3.3V
PAI_953	DAC_IDD (3 of 4)	DAC operating current	DAC Single ended mode, fs = 1 Msps, AVDD = 3.3V
PAI_955	ADC_IDD (1 of 2)	ADC operating current	Single-Ended Mode, fs = 1 Msps, REFCTRL.REFSEL = 0x3, VREF = AVDD = 3.3V
<b>MODULES/PERIPHERALS ACTIVE CURRENTS ≤ 550µA</b>			
PAI_1000	DAC_IDD (4 of 4)	DAC operating current	DAC Differential mode, fs = 1 Msps, AVDD = 3.3V
PAI_1001	ADC_IDD (2 of 2)	ADC operating current	Differential Mode, fs = 1 Msps, REFCTRL.REFSEL = 0x3, VREF = AVDD = 3.3V
<b>MODULES/PERIPHERALS ACTIVE CURRENTS ≤ 1mA</b>			
PAI_2000	DFLL48M_IDD	48Mhz Digital Frequency Locked Loop	Open Loop mode - DFLLVAL after reset VDD = 3.3V, Closed Loop mode - fREF = 32.768 kHz VDD = 3.3V
<b>MODULES/PERIPHERALS ACTIVE CURRENTS ≤ 1.5 mA</b>			
PAI_80004	TC_IDD	TC operating current	TC GCLK clock at 120MHz from DPLL, VDD = 3.3V

.....continued

DC CHARACTERISTICS			Standard Operating Conditions: VDD = AVDD = 1.71V to 3.63V (unless otherwise stated) Operating temperature: -40°C ≤ T <sub>A</sub> ≤ +85°C for Industrial Temperature
Param. No.	Symbol	Characteristics	Conditions
PAI_80002	I2S_IDD	I2S operating current	I2S GCLK clock at 120MHz from DPLL, VDD = 3.3V
PAI_80006	PDEC_IDD	PDEC operating current	PDEC GCLK clock at 120MHz from DPLL, VDD = 3.3V
PAI_4000	PTC_IDD	PTC, Peripheral Touch Controller, current	PTC running at 4 MHz, Mutual-Capacitance mode, One touch channel, Standby Sleep mode enabled, RTC running on ULP32K: used to define the PTC scan rate, through the event system, RTC interrupts (wake up) the CPU to perform PTC scans
PAI_4001	XOSC_IDD (1 of 4)	XOSC oscillator current consumption	Freq crystal 8-to-32Mhz, ENALC = ON
PAI_4002	XOSC_IDD (2 of 4)	XOSC oscillator current consumption	Freq crystal 48Mhz, ENALC = ON
PAI_8000	FDPLL_IDD (1 of 2)	Fractional Digital Phase Lock Loop current	Clk = 96 MHz, VDD = 3.3V
<b>MODULES/PERIPHERALS ACTIVE CURRENTS ≤ 2.5 mA</b>			
PAI_80003	PCC_IDD	PCC operating current	PCC GCLK clock at 120MHz from DPLL, VDD = 3.3V
PAI_80005	TCC_IDD	TCC operating current	TCC GCLK clock at 120MHz from DPLL, VDD = 3.3V
PAI_4003	XOSC_IDD (3 of 4)	XOSC oscillator current consumption	Freq crystal 8-to-16Mhz, ENALC = OFF
PAI_8001	FDPLL_IDD (2 of 2)	Fractional Digital Phase Lock Loop current	Clk = 200 MHz, VDD = 3.3V
<b>MODULES/PERIPHERALS ACTIVE CURRENTS ≤ 5 mA</b>			
PAI_4004	XOSC_IDD (4 of 4)	XOSC oscillator current consumption	Freq crystal 32-to-48Mhz, ENALC = OFF
<b>MODULES/PERIPHERALS ACTIVE CURRENTS ≤ 8 mA</b>			
PAI_40000	FLASH_IDD	Flash Erase and Programming Current	Flash Erase and Programming Current
PAI_80007	USB_IDD	USB operating current	USB GCLK from DFLL48M in clock recovery mode USB device attached to active USB Host
PAI_80000	GMAC_IDD	Ethernet operating current	GMAC running on system clock at 120MHz in MII or RMII mode , VDD = 3.3V
<b>Note:</b>			
1. These values are for worst case guidance only unless otherwise specified, actual values depend on user peripheral configuration and operating frequency.			



## 55.13 I/O Pin Electrical Specifications

Table 55-16. I/O Pin Electrical Specifications

AC/DC CHARACTERISTICS			Standard Operating Conditions: VDD = AVDD = 1.71V to 3.63V (unless otherwise stated) Operating temperature: -40°C ≤ T <sub>A</sub> ≤ +85°C for Industrial Temperature				
Param. No.	Symbol	Characteristics	Min.	Typ.	Max.	Units	Conditions
DI_1	VIL	Input Low Voltage I/O Pins	VSS AVSS	—	0.3 VDD 0.3 AVDD	V	—
DI_3	VIH	Input High Voltage I/O Pins	0.7 VDD 0.7 AVDD	—	VDD AVDD	V	—
DI_5	VOL	Output voltage low (Low Drive Strength, DRVSTR=0)	—	—	0.2 VDD 0.2 AVDD	V	VDD/AVDD = 3.3V @ IOL= 2mA
DI_7		Output voltage low (High Drive Strength, DRVSTR=1)					VDD/AVDD = 3.3V @ IOL= 8mA
DI_9	VOH	Output voltage High (Low Drive Strength, DRVSTR=0)	0.8 VDD 0.8 AVDD	—	—	V	VDD/AVDD = 3.3V @ IOH = 2 mA
DI_10		Output voltage High (High Drive Strength, DRVSTR = 1) I/O pins PA00, PA01, PB00, PB01, PB02, PB03, PC00, PC01					VDD/AVDD = 3.3V @ IOH = 6 mA
DI_11		Output voltage High (High Drive Strength, DRVSTR = 1) All I/O pins except DI_10 ones					VDD/AVDD = 3.3V @ IOH= 8mA
DI_13	IIL	Input pin leakage current	-1	—	1	µA	VSS/AVSS ≤ VPIN ≤ VDD/ AVDD(max) (VPIN = Voltage present on Pin)
DI_15	R <sub>PDWN</sub>	Internal Pull-Down (DIR = OUT = 0, PULLEN = 1). All I/O pins except PA24 and PA25.	20	—	60	kΩ	—
		Internal Pull-Down (DIR = OUT = 0, PULLEN = 1). I/O pins PA24 and PA25.	14	—	28	kΩ	
DI_17	R <sub>PUP</sub>	Internal Pull-Up (DIR = 0, OUT = PULLEN = 1)	20	—	60	kΩ	
DI_19	I <sub>ICL</sub> (1,3,4)	Input Low Injection Current	-15	—	—	mA	This parameter applies to all I/O pins.
DI_21	I <sub>ICH</sub> (2,3,4)	Input High Injection Current	—	—	15	mA	This parameter applies to all I/O pins
DI_23	Σ <sub>IICT</sub>	Total Input Injection Current (sum of all I/O and control pins) Absolute value of   ΣIICT	-45	—	45	mA	Absolute instantaneous sum of all ± input injection currents from all I/O pins. (   IICL   +   IICH   ) ≤ ΣIICT

.....continued

AC/DC CHARACTERISTICS			Standard Operating Conditions: VDD = AVDD = 1.71V to 3.63V (unless otherwise stated) Operating temperature: -40°C ≤ T <sub>A</sub> ≤ +85°C for Industrial Temperature				
Param. No.	Symbol	Characteristics	Min.	Typ.	Max.	Units	Conditions
DI_25	T <sub>RISE</sub>	I/O pin Rise Time (Low Drive Strength, DRVSTR=0)	—	—	49	ns	Normal Mode (all IO pins), CLOAD=30pF(MAX)
DI_26		I/O pin Rise Time (High Drive Strength, DRVSTR=1)	—	—	12	ns	
DI_27	T <sub>FALL</sub>	I/O pin Fall Time (Low Drive Strength, DRVSTR=0)	—	—	44	ns	
DI_28		I/O pin Fall Time (High Drive Strength, DRVSTR=1)	—	—	11	ns	
DI_29	T <sub>RISE_BACKUP</sub>	Backup I/O pin Rise Time	—	—	4	μs	Backup Pins (PA00, PA01, PB00, PB01, PB02, PB03, PC00, PC01) in Backup Mode, CLOAD=30pF(MAX)
DI_30	T <sub>FALL_BACKUP</sub>	Backup I/O pin Fall Time	—	—	4	μs	

**Notes:**

- VIL source < (VSS - 0.3). Characterized but not tested.
- VIH source > (VDD + 0.3).
- If the sum of all injection currents are > | $\sum I_{ICT}$ | it can affect the ADC results by approximately 4 to 6 counts (i.e., VIH Source > (VDD + 0.3) or VIL source < (VSS - 0.3)).
- Any number and/or combination of I/O pins not excluded under IICL or IICH conditions are permitted provided the “absolute instantaneous” sum of the input injection currents from all pins do not exceed the specified  $\sum I_{ICT}$  limit. To limit the injection current the user must insert a resistor in series R<sub>SERIES</sub>, (i.e. RS), between input source voltage and device pin. The resistor value is calculated according to:
  - For negative Input voltages less than (VSS-0.3):  $RS \geq \text{absolute value of } | (VIL \text{ source} - (VSS - 0.3)) / I_{ICL} |$
  - For positive input voltages greater than (VDD +0.3):  $RS \geq ((VIH \text{ source} - (VDD +0.3)) / I_{ICH})$
  - For Vpin voltages >VDD +0.3 and <VSS-0.3 then RS = the larger of the values calculated above

## 55.14 Internal Voltage Reference Electrical Specifications

**Table 55-17.** Internal Voltage Reference Electrical Specifications

DC CHARACTERISTICS			Standard Operating Conditions: VDD = AVDD = 1.71V to 3.63V (unless otherwise stated) Operating temperature: -40°C ≤ T <sub>A</sub> ≤ +85°C for Industrial Temperature				
Param. No.	Symbol	Characteristics	Min.	Typ.	Max.	Units	Conditions
VR_1	I <sub>REF</sub>	Internal Voltage Reference ADC.REFCTRL.REFSEL = INTREF DAC.CTRLB.REFSEL = INTREF	2.282	2.4	2.513	V	AVDD = 3.3V, T <sub>A</sub> = 25°C AVDD(min) +0.6 ≥ INTERNAL Voltage Reference. SUPC VREF.SEL = 0x6
VR_3			2.380	2.5	2.615	V	AVDD = 3.3V, T <sub>A</sub> = 25°C AVDD(min) +0.6 ≥ INTERNAL Voltage Reference. SUPC VREF.SEL = 0x7
VR_9	AC <sub>IREF</sub>	Internal Comparator Voltage Reference AC.COMPCTRLn.MUXNEG = BANDGAP	1.074	1.1	1.125	V	AVDD = 3.3V, T <sub>A</sub> = 25°C
VR_25	T <sub>DRIFT</sub>	Internal Voltage Reference Temperature Drift	-0.02	---	0.03	%/°C	Over full operating temperature range
VR_27	V <sub>DRIFT</sub>	Internal Voltage Reference Voltage Drift	-0.2	---	0.7	%/V	Over full operating voltage range

## 55.15 Maximum Clock Frequencies Electrical Specifications

**Table 55-18.** Maximum Clock Frequencies Electrical Specifications

AC CHARACTERISTICS		Standard Operating Conditions: VDD = AVDD = 1.71V to 3.63V (unless otherwise stated) Operating temperature: -40°C ≤ T <sub>A</sub> ≤ +85°C for Industrial Temperature		
Param. No.	Symbol	Characteristics	Max.	Units
FCLK_1	fCPU	CPU clock freq	120	MHz
FCLK_3	fAHB	AHB clock freq	120	MHz
FCLK_5	fAPBx	APBA, APBB, APBC, APBD clock freq	120	MHz
FCLK_6	fHS	High Speed (HS) clock freq	132	MHz
FCLK_7	fGCLK_DPLLx	FDPLL0 and FDPLL1 reference clock freq	3.2	MHz
FCLK_9	fGCLK_DPLLx_32K	FDPLL0 and FDPLL1 32k reference clock freq	100	MHz
FCLK_11	fGCLK_DFLL48M_REF	DFLL48M reference clock freq	33	kHz
FCLK_13	fGCLK_EIC	EIC input clock freq	100	MHz
FCLK_15	fGCLK_FREQM_MSR	FREQM Measure Clock Frequency	200	MHz
FCLK_17	fGCLK_FREQM_REF	FREQM Reference Clock Frequency	100	MHz
FCLK_19	fGCLK_EVSYS_CHANNELx	EVSYS channel x input clock freq	100	MHz
FCLK_21	fGCLK_SERCOMx_SLOW	Common SERCOM slow input clock freq	12	MHz
FCLK_23	fGCLK_SERCOMx_CORE	SERCOMx input clock freq	100	MHz
FCLK_25	fGCLK_CANx	CAN input clock freq	100	MHz
FCLK_27	fGCLK_USB	USB input clock freq	60	MHz
FCLK_29	fGCLK_I2S	I2S input clock freq	100	MHz
FCLK_31	fGCLK_SDHCx_SLOW	Common SDHC slow input clock freq	12	MHz
FCLK_33	fGCLK_SDHCx_CORE	SDHCx input clock freq	150	MHz
FCLK_35	fGCLK_TCCx	TCCx input clock freq	200	MHz
FCLK_37	fGCLK_TCx	TC0, TC1, TC2, TC3 input clock freq	200	MHz
FCLK_39	fGCLK_TCx	TC4, TC5, TC6, TC7 input clock freq	100	MHz
FCLK_41	fGCLK_PDEC	PDEC input clock freq	200	MHz
FCLK_43	fGCLK_CCL	CCL input clock freq	100	MHz
FCLK_45	fGCLK_GCLKINx	External GCLKx input clock freq	50	MHz
FCLK_47	fGCLK_CM4_TRACE	Cortex-M4 Trace input clock freq	120	MHz
FCLK_49	fGCLK_AC	Analog comparator peripheral module clock freq	100	MHz
FCLK_51	fGCLK_ADCx	ADCx input clock freq	100	MHz
FCLK_53	fGCLK_DAC	DAC input clock freq	100	MHz

## 55.16 XOSC Maximum Clock Frequencies Electrical Specifications

**Table 55-19.** External XTAL and Clock Electrical Specifications

AC CHARACTERISTICS			Standard Operating Conditions: VDD = AVDD = 1.71V to 3.63V (unless otherwise stated) Operating temperature: -40°C ≤ T <sub>A</sub> ≤ +85°C for Industrial Temperature				
Param. No.	Symbol	Characteristics	Min.	Typ.	Max.	Units	Conditions
XOSC_1	F <sub>OSC_XOSC</sub>	XOSC Crystal Frequency	8	—	48	MHz	XOSCCTRLn.XTALEN=1 XIN, XOUT Primary Osc
XOSC_1A	T <sub>OSC</sub>	T <sub>OSC</sub> = 1/ FOSC_XOSC	20.833	—	125	ns	—
XOSC_2	X <sub>OSC_ST</sub> <sup>(1)</sup>	XOSC Crystal Start-up Time	—	39700	Note (2)	T <sub>OSC</sub>	—
XOSC_3	C <sub>XIN</sub>	XOSC XIN parasitic pin capacitance	—	6.3	—	pF	—
XOSC_5	C <sub>XOUT</sub>	XOSC XOUT parasitic pin capacitance	—	5.9	—	pF	—
XOSC_11	C <sub>LOAD</sub> <sup>(3)</sup>	XOSC Crystal FOSC = 8MHz	—	—	20	pF	XOSCCTRLn.ENALC = n/a XOSCCTRLn.LOWBUFGAIN = 0x0 XOSCCTRLn.IMULT = 0x3 XOSCCTRLn.IPTAT = 0x2
XOSC_13		XOSC Crystal FOSC = 16MHz	—	—	20	pF	XOSCCTRLn.ENALC = _n/a XOSCCTRLn.LOWBUFGAIN = 0x0 XOSCCTRLn.IMULT = 0x4 XOSCCTRLn.IPTAT = 0x3
XOSC_15		XOSC Crystal FOSC = 24MHz	—	—	20	pF	XOSCCTRLn.ENALC = _n/a XOSCCTRLn.LOWBUFGAIN = 0x0 XOSCCTRLn.IMULT = 0x5 XOSCCTRLn.IPTAT = 0x3
XOSC_17		XOSC Crystal FOSC = 48MHz	—	—	13	pF	XOSCCTRLn.ENALC = _n/a XOSCCTRLn.LOWBUFGAIN = 0x0 XOSCCTRLn.IMULT = 0x6 XOSCCTRLn.IPTAT = 0x3

.....continued

AC CHARACTERISTICS			Standard Operating Conditions: VDD = AVDD = 1.71V to 3.63V (unless otherwise stated) Operating temperature: -40°C ≤ T <sub>A</sub> ≤ +85°C for Industrial Temperature				
Param. No.	Symbol	Characteristics	Min.	Typ.	Max.	Units	Conditions
XOSC_21	ESR	XOSC Crystal FOSC = 8MHz	—	—	181	Ω	XOSCCTRLn.ENALC = n/a XOSCCTRLn.LOWBUFGAIN = 0x0 XOSCCTRLn.IMULT = 0x3 XOSCCTRLn.IPTAT = 0x2 CLOAD = 20pF
XOSC_23		XOSC Crystal FOSC = 16MHz	—	—	180	Ω	XOSCCTRLn.ENALC = _n/a XOSCCTRLn.LOWBUFGAIN = 0x0 XOSCCTRLn.IMULT = 0x4 XOSCCTRLn.IPTAT = 0x3 CLOAD = 20pF
XOSC_25		XOSC Crystal FOSC = 24MHz	—	—	70	Ω	XOSCCTRLn.ENALC = _n/a XOSCCTRLn.LOWBUFGAIN = 0x0 XOSCCTRLn.IMULT = 0x5 XOSCCTRLn.IPTAT = 0x3 CLOAD = 20pF
XOSC_27		XOSC Crystal FOSC = 48MHz	—	—	70	Ω	XOSCCTRLn.ENALC = _n/a XOSCCTRLn.LOWBUFGAIN = 0x0 XOSCCTRLn.IMULT = 0x6 XOSCCTRLn.IPTAT = 0x3 CLOAD = 13pF
XOSC_33	DLEVEL	MCU Crystal Osc Power Drive Level	—	—	1000	μW	XOSCCTRLn.XTALEN=1, ENALC = ON
XOSC_35	F <sub>osc_XCLK</sub>	Ext Clock Oscillator Input Freq (XIN pin)	0	—	48	MHz	XOSCCTRLn.XTALEN=0
XOSC_37	XCLK_DC	Ext Clock Oscillator (XIN) Duty Cycle	40	50	60	%	XOSCCTRLn.XTALEN=0
XOSC_39	XCLK_FST	Primary XIN Clock Fail Safe Time-out Period	—	$\frac{4*1}{(DFLL\_1/2^{*}XOSCCTRLn.CFDPRESC)}$	—	μs	DFLL48M in open loop, DFLLCTRLB.MODE=0, DFLL_1: Refer to <a href="#">DFLL48M Electrical Specifications</a>
			—	$\frac{4*1}{(DFLL\_13/2^{*}XOSCCTRLn.CFDPRESC)}$	—		DFLL48M in closed loop, DFLLCTRLB.MODE=1, DFLL_13: Refer to <a href="#">DFLL48M Electrical Specifications</a>

.....continued

AC CHARACTERISTICS			Standard Operating Conditions: VDD = AVDD = 1.71V to 3.63V (unless otherwise stated) Operating temperature: -40°C ≤ T <sub>A</sub> ≤ +85°C for Industrial Temperature				
Param. No.	Symbol	Characteristics	Min.	Typ.	Max.	Units	Conditions

**Notes:**

1. This is for guidance only. A major component of crystal start-up time is based on the second party crystal MFG parasitics that are outside the scope of this specification. If this is a major concern the customer would need to characterize this based on their design choices.
2. Maximum start up time user selectable in XOSCCTRLn.STARTUP.
3. CRYSTAL LOAD CAPACITOR CALCULATION GIVEN:
  - Standard PCB trace capacitance = 1.5 pF per 12.5 mm(0.5 inches) (i.e. PCB STD TRACE W=0.175 mm, H=36 μm, T=113 μm)
  - X<sub>TAL</sub> PCB capacitance typical therefore ≈ 2.5pF for a tight PCB X<sub>TAL</sub> layout
  - For C<sub>XIN</sub> and C<sub>XOUT</sub> within 4pF of each other, Assume C<sub>X<sub>TAL</sub>EFF</sub> = ((C<sub>XIN</sub>+C<sub>XOUT</sub>) / 2)

**Note:** Averaging C<sub>XIN</sub> and C<sub>XOUT</sub> will effect final calculated C<sub>LOAD</sub> value by less than 0.25pF.

**EQUATION 1:**

MFG C<sub>LOAD</sub> Spec = {([C<sub>XIN</sub> + C1] \* [C<sub>XOUT</sub> + C2]) / [C<sub>XIN</sub> + C1 + C2 + C<sub>XOUT</sub>]} + estimated oscillator PCB stray capacitance

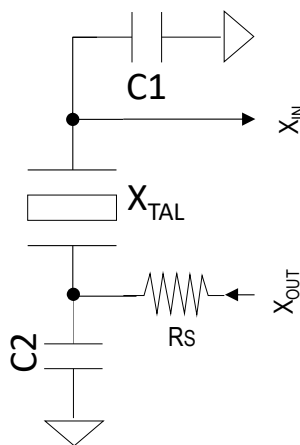
- Assuming C1 = C2 and C<sub>XIN</sub> ≈ C<sub>XOUT</sub>, the formula can be further simplified and restated to solve for C1 and C2 by:

**EQUATION 2:**

(i.e. Simplified Equation #1) C1 = C2 = ((2 \* MFG C<sub>LOAD</sub> spec) - C<sub>X<sub>TAL</sub>EFF</sub> - (2 \* PCB capacitance))

**EXAMPLE ONLY:**

- XTAL Mfg C<sub>LOAD</sub> Data Sheet Spec = 12pF
- PCB X<sub>TAL</sub> trace Capacitance = 2.5pF
- C<sub>XIN</sub> pin = 6.5pF, C<sub>XOUT</sub> pin = 4.5pF therefore C<sub>X<sub>TAL</sub>EFF</sub> = ((C<sub>XIN</sub>+C<sub>XOUT</sub>) / 2) C<sub>X<sub>TAL</sub>EFF</sub> = ((6.5 + 4.5)/2) = 5.5pF
- C1 = C2 = ((2 \* MFG C<sub>LOAD</sub> spec) - C<sub>X<sub>TAL</sub>EFF</sub> - (2 \* PCB capacitance))
- C1 = C2 = (24 - 5.5 - (2 \* 2.5))
- C1 = C2 = 13.5pF (Always rounded down)
- C1 = C2 = 13pF (i.e. for hypothetical example crystal external load capacitors)
- User C1=C2=13pF C<sub>LOAD(max)</sub> specification



## 55.17 XOSC32K Electrical Specifications

Table 55-20. XOSC32K Electrical Specifications

AC CHARACTERISTICS			Standard Operating Conditions: VDD = AVDD = 1.71V to 3.63V (unless otherwise stated) Operating temperature: -40°C ≤ T <sub>A</sub> ≤ +85°C for Industrial Temperature				
Param. No.	Symbol	Characteristics	Min.	Typ.	Max.	Units	Conditions
XOSC32_1	F <sub>OSC_XOSC32</sub>	XOSC32 Oscillator Crystal Frequency	—	32.768	—	kHz	XIN32, XOUT32 Secondary Osc
XOSC32_3	C <sub>XIN32</sub>	XOSC32 X <sub>IN32</sub> parasitic pin capacitance	—	3.1	—	pF	—
XOSC32_5	C <sub>XOUT32</sub>	XOSC32 X <sub>OUT32</sub> parasitic pin capacitance	—	3.2	—	pF	—
XOSC32_11	C <sub>LOAD_X32</sub> <sup>(3)</sup>	32.768 kHz Crystal Load Capacitance	—	—	12.5	pF	XOSC32K.CGM = 1 XOSC32K.XTALEN = 1 XOSC32K.ENABLE = 1
XOSC32_12			—	—	12.5	pF	XOSC32K.CGM = 2 XOSC32K.XTALEN = 1 XOSC32K.ENABLE = 1
XOSC32_13	ESR_X32	32.768 kHz Crystal ESR	—	—	58	kΩ	XOSC32K.CGM = 1 XOSC32K.XTALEN = 1 XOSC32K.ENABLE = 1 CLOAD = 12.5pF
XOSC32_14			—	—	90	kΩ	XOSC32K.CGM = 2 XOSC32K.XTALEN = 1 XOSC32K.ENABLE = 1 CLOAD = 12.5pF
XOSC32_15	T <sub>OSC32</sub>	T <sub>OSC32</sub> = 1/ F <sub>OSC_XOSC32</sub>	—	30.5176	—	μs	See parameter XOSC32_1 for FOSC_XOSC32 value
XOSC32_17	XOSC32_ST <sup>(1)</sup>	XOSC32 Crystal Start-up Time	—	12000	Note <sup>(2)</sup>	T <sub>OSC32</sub>	—
XOSC32_19	F <sub>OSC_XCLK32</sub>	Ext Clock Oscillator Input Freq (X <sub>IN32</sub> pin)	—	32.768	—	kHz	XOSC32K.XTALEN=0 XOSC32K.ENABLE = 1
XOSC32_21	XCLK32_DC	Ext Clock Oscillator Duty Cycle	40	50	60	%	XOSC32K.XTALEN=0 XOSC32K.ENABLE = 1
XOSC32_23	XCLK32_FST	XIN32 Clock Fail Safe Time-out Period	—	4*1/ (LP32K_1/2^CFDCTRL.CFDPRES)	—	ms	LP32K_1: Refer to <a href="#">OSCULP32K Electrical Specifications</a>



.....continued

AC CHARACTERISTICS			Standard Operating Conditions: VDD = AVDD = 1.71V to 3.63V (unless otherwise stated) Operating temperature: -40°C ≤ T <sub>A</sub> ≤ +85°C for Industrial Temperature				
--------------------	--	--	---	--	--	--	--

Param. No.	Symbol	Characteristics	Min.	Typ.	Max.	Units	Conditions
------------	--------	-----------------	------	------	------	-------	------------

**Notes:**

- This is for guidance only. A major component of crystal start-up time is based on the second party crystal MFG parasitics that are outside the scope of this specification. If this is a major concern the customer would need to characterize this based on their design choices.
- Maximum start up time user selectable in XOSC32K.STARTUP.
- CRYSTAL LOAD CAPACITOR CALCULATION GIVEN:
  - Standard PCB trace capacitance = 1.5 pF per 12.5 mm(0.5 inches) (i.e. PCB STD TRACE W=0.175 mm, H=36 μm, T=113 μm)
  - X<sub>TAL</sub> PCB capacitance typical therefore ≈ 2.5pF for a tight PCB X<sub>TAL</sub> layout
  - For C<sub>XIN</sub> and C<sub>XOUT</sub> within 4pF of each other, Assume C<sub>X<sub>TAL</sub>EFF</sub> = ((C<sub>XIN</sub>+C<sub>XOUT</sub>) / 2)
  - Note:** Averaging C<sub>XIN</sub> and C<sub>XOUT</sub> will effect final calculated C<sub>LOAD</sub> value by less than the tolerance of the capacitor selection.

**EQUATION 1:**

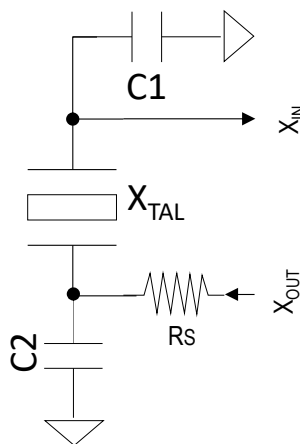
MFG C<sub>LOAD</sub> Spec = {([C<sub>XIN</sub> + C1] \* [C<sub>XOUT</sub> + C2]) / [C<sub>XIN</sub> + C1 + C2 + C<sub>XOUT</sub>]} + estimated oscillator PCB stray capacitance

- Assuming C1 = C2 and C<sub>XIN</sub> ≈ C<sub>XOUT</sub>, the formula can be further simplified and restated to solve for C1 and C2 by:  
EQUATION 2: (i.e. Simplified Equation #1)

$$C1 = C2 = ((2 * MFG C_{LOAD} spec) - C_{XTAL\_EFF} - (2 * PCB capacitance))$$

**EXAMPLE ONLY:**

- X<sub>TAL</sub> Mfg C<sub>LOAD</sub> Data Sheet Spec = 12pF
- PCB X<sub>TAL</sub> trace Capacitance = 2.5pF
- C<sub>XIN</sub> pin = 6.5pF, C<sub>XOUT</sub> pin = 4.5pF therefore C<sub>X<sub>TAL</sub>EFF</sub> = ((C<sub>XIN</sub>+C<sub>XOUT</sub>) / 2) C<sub>X<sub>TAL</sub>EFF</sub> = ((6.5 + 4.5)/2) = 5.5pF
- C1 = C2 = ((2 \* MFG C<sub>LOAD</sub> spec) - C<sub>X<sub>TAL</sub>EFF</sub> - (2 \* PCB capacitance))
- C1 = C2 = (24 - 5.5 - (2 \* 2.5))
- C1 = C2 = (24 - 5.5 - 5)
- C1 = C2 = 13.5pF (Always rounded down)
- C1 = C2 = 13pF (i.e. for hypothetical example crystal external load capacitors)
- User C1=C2=13pF ≤ C<sub>LOAD\_X32</sub>(max) specification



## 55.18 OSCULP32K Electrical Specifications

**Table 55-21.** Low Power Internal 32 kHz RC Oscillator Electrical Specifications

AC CHARACTERISTICS			Standard Operating Conditions: VDD = AVDD = 1.71V to 3.63V (unless otherwise stated) Operating temperature: -40°C ≤ T <sub>A</sub> ≤ +85°C for Industrial Temperature				
Param. No.	Symbol	Characteristics	Min.	Typ.	Max.	Units	Conditions
LP32K_1	FOSC_LPRC32K	Output Frequency	—	32.768	—	kHz	—
LP32K_3	LPRC32K_ACC	Accuracy	-17.2	—	15	%	—
LP32K_9	RC32K_Duty	LPRC32K OSC Duty Cycle	—	50	—	%	—

## 55.19 DFLL48M Electrical Specifications

**Table 55-22.** Digital Frequency Locked Loop (DFLL48M) Electrical Specifications

AC CHARACTERISTICS			Standard Operating Conditions: VDD = AVDD = 1.71V to 3.63V (unless otherwise stated) Operating temperature: -40°C ≤ T <sub>A</sub> ≤ +85°C for Industrial Temperature				
Param. No.	Symbol	Characteristics	Min.	Typ.	Max.	Units	Conditions
<b>DFLL48M (Open Loop)</b> <sup>(1,2)</sup>							
DFLL_1	DFLL_OL_F <sub>OUT</sub>	DFLL Open Loop Clock Frequency	45.8	48	49.3	MHz	LDO Mode
DFLL_9	DFLL_OL_SRT	Start-Up (Ready bit valid)	—	—	7	μs	LDO Mode FOUT within 90% of final value
<b>DFLL48M (Closed Loop)</b> <sup>(1,3,4,6)</sup>							
DFLL_11	DFLL_CL_F <sub>IN</sub>	DFLL Closed loop Input Frequency Range	732	32768	33000	Hz	LDO Mode
DFLL_13	DFLL_CL_F <sub>OUT</sub>	DFLL Closed Loop Clock Frequency	—	47.972	—	MHz	LDO Mode XOSC32 32.768kHz PPM≤100, DFLLMUL = 1464
DFLL_15	DFLL_CL_Jitter	DFLL Period Jitter Pk-to-Pk	—	—	2	%	LDO Mode XOSC32 32.768kHz PPM≤100, DFLLMUL = 1464
DFLL_21	DFLL_CL_SRT <sup>(5)</sup>	DFLL Closed Loop Mode / Lock Time	—	—	1145	μs	LDO Mode XOSC32 32.768kHz PPM≤100, DFLLMUL = 1464
<b>Notes:</b>							
<ol style="list-style-type: none"> <li>DFLL48 in open or close loop can be used only with LDO regulator.</li> <li>Not recommended for functional USB operation, SOF sync start-up only.</li> <li>In Closed loop mode the DFLL can use a variety of clock sources. The DFLL can be trimmed using register DFLLMUL.</li> <li>To ensure that the device stays within the maximum allowed clock frequency, any reference clock for DFLL in close loop must be within a 2% error accuracy.</li> <li>DFLLMUL = 1464, DFLLCTRL.BPLCKC = 1: only fine value change, coarse value locked to the reset value. DFLLCTRL.QLDIS = 0: quick lock enable, DFLLCTRL.CCDIS = 1: Enabling chill cycles might double the lock time. DFLLMUL.FSTEP = 10 : Max fine step size, divided or dividing into two parts, search. 10 is a optimum value.</li> <li>During a maximum 30 cycles of the reference clock period, between lock flag asserted and frequency stabilization, DFLL accuracy will be limited. To minimize the cycle-to-cycle jitter during lock search, in addition to selecting a low step value (DFLLMUL.FSTEP, DFLLMUL.CSTEP), it is recommended to disable the Quick Lock feature.</li> </ol>							

## 55.20 FDPLL200M Electrical Specifications

**Table 55-23.** Frequency Digital Phase Locked Loop (FDPLL200M) Electrical Specifications

AC CHARACTERISTICS			Standard Operating Conditions: VDD = AVDD = 1.71V to 3.63V (unless otherwise stated) Operating temperature: -40°C ≤ T <sub>A</sub> ≤ +85°C for Industrial Temperature				
Param. No.	Symbol	Characteristics	Min.	Typ.	Max.	Units	Conditions
<b>FDPLL200M (Fractional Digital Phase Locked Loop) <sup>(1)</sup></b>							
FDPLL_1	FDPLL_F <sub>IN</sub>	FDPLL Input Frequency Range	32	—	3200	kHz	—
FDPLL_3	FDPLL_F <sub>OUT</sub>	FDPLL Output Clock Frequency	96	—	200	MHz	—
FDPLL_5	FDPLL_Jitter <sup>(2)</sup>	FDPLL Period Jitter Pk-to-Pk	—	—	2.7	%	LDO Mode, fEXTERNAL=32.768kHz PPM≤100, fOUT(max)= 96MHz
			—	—	4.9	%	LDO Mode, fEXTERNAL=32.768kHz PPM≤100, fOUT(max)= 200MHz
			—	—	3.0	%	LDO Mode, fEXTERNAL=3.2MHz PPM≤100, fOUT(max)= 96MHz
			—	—	6.6	%	LDO Mode, fEXTERNAL=3.2MHz PPM≤100, fOUT(max)= 200MHz
FDPLL_11	FDPLL_SRT <sup>(2)</sup>	FDPLL Start-Up / Lock Time	—	—	95	μs	fEXTERNAL=3.2MHz PPM≤100,
<b>Notes:</b>							
1. FDPLL200M can be used only with LDO regulator.							
2. REFCLK for FDPLL200M is XOSC or XOSC32K.							

## 55.21 DAC Module Electrical Specifications

Table 55-24. DAC Module Electrical Specifications

AC CHARACTERISTICS				Standard Operating Conditions: VDD = AVDD = 1.71V to 3.63V (unless otherwise stated) Operating temperature: -40°C ≤ T <sub>A</sub> ≤ +85°C for Industrial Temperature				
Param. No.	Symbol	Characteristics		Min.	Typ.	Max.	Units	Conditions
DAC_1	D <sub>RES</sub>	DAC Resolution		—	—	12	Bits	—
DAC_3	D <sub>CLK</sub>	Internal DAC Clock Frequency (GCLK_DAC)		—	—	12	MHz	—
DAC_5	D <sub>SAMP</sub>	DAC Sampling Rate	Low Power DACCTRLn.CCTRL[1:0] = 0	0.1	—	0.1	Msp/s	+/-4LSB of final value for step size ≤ 100LSb at CLOAD and RLOAD w/ AVDD = 3.3V
			High Power DACCTRLn.CCTRL[1:0] = 2	0.1	—	1	Msp/s	
DAC_7	V <sub>OUT</sub>	Output Voltage Linear Range		AVSS+0.15	—	AVDD-0.15	V	Ext Pin(Buffered) VREF=AVDD at CLOAD and RLOAD
				AVSS+0.15	—	VREF	V	Ext Pin(Buffered) VREF ≤ AVDD-150mV at CLOAD and RLOAD
				AVSS	—	VREF	V	Internal connection to another module (eg AC) (No buffer)
DAC_9	V <sub>REF</sub> <sup>(1,2)</sup>	DAC Reference Input Option	REFSEL=VREFAB CTRLB.REFSEL[1:0] = 0x2	2.4V	—	AVDD-0.15	V	External Reference VREFAB (buffered) VREF bypass Cap = 0.01µF
			REFSEL=VREFAU CTRLB.REFSEL[1:0] = 0x0		—	AVDD	V	External Reference VREFAU (unbuffered) VREF bypass Cap = 0.01µF
			REFSEL=INTREF CTRLB.REFSEL[1:0] = 0x3		VR_1 VR_3	AVDD-0.15	V	Internal Reference VR_1, VR_3: Refer to <a href="#">Internal Voltage Reference Electrical Specifications</a>
			REFSEL=AVDD CTRLB.REFSEL[1:0] = 0x1		—	AVDD	V	—
DAC_11	C <sub>LOAD</sub>	DAC Out max load to meet VOUT and TSET		—	—	50	pF	—
DAC_13	R <sub>LOAD</sub>	DAC Out max load to meet VOUT and TSET		5	—	—	kΩ	—
DAC_15	T <sub>SET</sub> <sup>(6)</sup>	DAC Settling Time	Low Power / REFSEL=AVDD DACCTRLn.CCTRL[1:0]=0	—	—	(1/ DSAMPmin) +1	µs	+/-4LSB of final value for step size ≤ 100LSb at CLOAD and RLOAD w/ AVDD = 3.3V
			High Performance / REFSEL=AVDD DACCTRLn.CCTRL[1:0] = 2	—	—	(1/ DSAMPmin) +1	µs	+/-4LSB of final value for step size ≤ 100LSb at CLOAD and RLOAD w/ AVDD = 3.3V

.....continued

AC CHARACTERISTICS				Standard Operating Conditions: VDD = AVDD = 1.71V to 3.63V (unless otherwise stated) Operating temperature: -40°C ≤ T <sub>A</sub> ≤ +85°C for Industrial Temperature				
Param. No.	Symbol	Characteristics		Min.	Typ.	Max.	Units	Conditions
DAC_17	T <sub>SET_FS</sub> <sup>(6)</sup>	DAC Full Scale Settling Time	Low Power / REFSEL=AVDD DACCTRLn.CCTRL[1:0] = 0	—	—	(7/ DSAMPmin) +1	μs	+/-4LSB of final value for step size from 10% to 90% at CLOAD and RLOAD w/ AVDD = 3.3V
			High-Performance/ REFSEL= AVDD DACCTRLn.CCTRL[1:0] = 2	—	—	(7/ DSAMPmin) +1	μs	+/-4LSB of final value for step size from 10% to 90% at CLOAD and RLOAD w/ AVDD = 3.3V
<b>DIFFERENTIAL MODE</b> <sup>(1,2,4,5)</sup>								
DDAC_19	INL	Integral Non Linearity		-3.4	—	3.4	LSB	1Msps, External VREF REFSEL= VREFAB = 2.4V CTRLB.REFSEL[1:0] = 0x2, AVDD = VDD = 3.3V w/ CLOAD and RLOAD.
DDAC_21	DNL	Differential Non Linearity		-3.6	—	3.6	LSB	
DDAC_23	G <sub>ERR</sub>	Gain Error	—	-69.7	—	69.7	LSB	
DDAC_25	E <sub>OFF</sub>	Offset Error	—	-68.3	—	68.3	LSB	1Msps, External VREF REFSEL= VREFAB= 2.4V CTRLB.REFSEL[1:0] = 0x2, AVDD = VDD = 3.3V w/ CLOAD and RLOAD.
DDAC_27	ENOB <sup>(7)</sup>	Effective Number of Bit		9.9	—	—	Bits	1Msps, External VREF REFSEL= VREFAB = 2.4V CTRLB.REFSEL[1:0] = 0x2, AVDD = VDD = 3.3V w/ CLOAD and RLOAD.
DDAC_29	SNR <sup>(7)</sup>	Signal To Noise Ratio		63.5	—	—	db	
DDAC_31	THD <sup>(3,7)</sup>	Total Harmonic Distortion		—	—	-61	db	
<b>SINGLE ENDED MODE</b> <sup>(1,2,4,5)</sup>								
SDAC_19	INL	Integral Non Linearity		-4	—	4	LSB	1Msps, External VREF REFSEL= VREFAB = 2.4V CTRLB.REFSEL[1:0] = 0x2, AVDD = VDD = 3.3V w/ CLOAD and RLOAD.
SDAC_21	DNL	Differential Non Linearity		-6.1	—	6.1	LSB	
SDAC_23	G <sub>ERR</sub>	Gain Error	—	-61.5	—	61.5	LSB	
SDAC_25	E <sub>OFF</sub>	Offset Error	—	-35.9	—	35.9	LSB	1Msps, External VREF REFSEL= VREFAB = 2.4V CTRLB.REFSEL[1:0] = 0x2, AVDD = VDD = 3.3V w/ CLOAD and RLOAD.
SDAC_27	ENOB <sup>(7)</sup>	Effective Number of Bit		9.1	—	—	Bits	1Msps, External VREF REFSEL= VREFAB = 2.4V CTRLB.REFSEL[1:0] = 0x2, AVDD = VDD = 3.3V w/ CLOAD and RLOAD.
SDAC_29	SNR <sup>(7)</sup>	Signal To Noise Ratio		63.5	—	—	dB	
SDAC_31	THD <sup>(3,7)</sup>	Total Harmonic Distortion		—	—	-61	dB	

.....continued

AC CHARACTERISTICS			Standard Operating Conditions: VDD = AVDD = 1.71V to 3.63V (unless otherwise stated) Operating temperature: -40°C ≤ T <sub>A</sub> ≤ +85°C for Industrial Temperature				
Param. No.	Symbol	Characteristics	Min.	Typ.	Max.	Units	Conditions

**Notes:**

1. DAC reference voltages < 2.4V, is not practical and peripheral performance is not guaranteed.
2. DAC functional device operation with external VREF<2.4V is guaranteed, but not characterized. DAC will function, but with degraded performance. DAC accuracy is limited by users application noise/accuracy on AVDD, AVSS and VREF accuracy/drift.
3. Value taken over 7 harmonics.
4. 12-bit mode.
5. Over VOUT range defined by DAC\_7 parameter.
6. Assuming DAC is configured and that first conversion is done.
7. Characterized with 15 kHz sine wave and low pass filter at 250 kHz.

## 55.22 ADC Electrical Specifications

Table 55-25. ADC Electrical Specifications

AC CHARACTERISTICS			Standard Operating Conditions: VDD = AVDD = 1.71V to 3.63V (unless otherwise stated) Operating temperature: -40°C ≤ T <sub>A</sub> ≤ +85°C for Industrial Temperature				
Param. No.	Symbol	Characteristics	Min.	Typ.	Max.	Units	Conditions
<b>Device Supply</b>							
ADC_1	AVDD	ADC Module Supply	AVDD(min)	—	AVDD(max)	V	—
<b>Reference Inputs</b>							
ADC_3	V <sub>REF</sub> <sup>(1)</sup>	ADC Reference Voltage	The greater of AVDD(min) or 2.4V	—	AVDD-0.4	V	External Reference VREF ≤ AVDD -0.4V
					AVDD	V	Internal Reference VREF ≤ AVDD
<b>Analog Input Range</b>							
ADC_7	A <sub>FS</sub>	Full-Scale Analog Input Signal Range	AVSS	—	VREF	V	Single-Ended
ADC_9			-VREF	—	+VREF	V	Differential
ADC10	V <sub>CMIN</sub>	Input common mode voltage	AVSS	VREF/2	AVDD	—	CTRLA.R2R =1
			Note <sup>(2)</sup>	VREF/2	Note <sup>(2)</sup>	—	CTRLA.R2R =0
ADC_11	T <sub>SETTLING</sub>	ADC Stabilization Time	—	10	—	µs	CTRLA.ENABLE=1 or CTRLA.ONDEMAND=1
<b>Notes:</b>							
1. ADC functional device operation with external V <sub>REF</sub> <2.4V is functional, but not characterized. ADC will function, but with degraded accuracy of approximately $\sim(0.06 * 2^n) / V_{REF}$ LSB's over full scale range, where "n"= # bits. ADC accuracy is limited by internal V <sub>REF</sub> accuracy + drift, MCU generated noise plus users application noise/accuracy on AVDD, AVSS.							
2. Limit the input common mode voltage using the following equations (where, V <sub>CMIN</sub> is the input channel common mode voltage): When CTRLA.R2R = 0: <ul style="list-style-type: none"> <li>- V<sub>CMIN</sub> &lt; 0.75*V<sub>REF</sub></li> <li>- V<sub>CMIN</sub> &gt; Maximum of (0, V<sub>REF</sub>-AVDD-0.7, 1.25*V<sub>REF</sub>-AVDD)</li> </ul> These values are based on simulation. They are not covered by production test limits or characterization.							

Table 55-26. ADC Single Ended Mode Electrical Specifications

AC CHARACTERISTICS			Standard Operating Conditions: VDD = AVDD = 1.71V to 3.63V (unless otherwise stated) Operating temperature: -40°C ≤ T <sub>A</sub> ≤ +85°C for Industrial Temperature				
Param. No.	Symbol	Characteristics	Min.	Typ.	Max.	Units	Conditions
<b>SINGLE ENDED MODE ADC Accuracy <sup>(4)</sup></b>							
SADC_11	Res	Resolution	8	—	12	bits	Selectable 8, 10, 12 bit Resolution Ranges
SADC_13	ENOB <sup>(1,2)</sup>	Effective Number of bits	8.9	—	—	bits	1Msps, Internal VREF= AVDD=VDD=3.3V
SADC_15			8.9	—	—	bits	1Msps, External VREF=2.4V, AVDD=VDD=3.3V
SADC_19	INL	Integral Nonlinearity	-3.2	—	3.2	LSB	1Msps, Internal VREF=AVDD=VDD=3.3V
SADC_21			-3.5	—	3.5	LSB	1Msps, External VREF=2.4V, AVDD=VDD=3.3V
SADC_25	DNL	Differential Nonlinearity	-1	—	1	LSB	1Msps, Internal VREF=AVDD=VDD=3.3V
SADC_27			-1	—	1.1	LSB	1Msps, External VREF=2.4V, AVDD=VDD=3.3V



.....continued

AC CHARACTERISTICS			Standard Operating Conditions: VDD = AVDD = 1.71V to 3.63V (unless otherwise stated) Operating temperature: -40°C ≤ T <sub>A</sub> ≤ +85°C for Industrial Temperature				
Param. No.	Symbol	Characteristics	Min.	Typ.	Max.	Units	Conditions
SADC_31	GERR	Gain Error	-12.3	—	12.3	LSB	1 Msps, Internal VREF=AVDD=VDD=3.3V, REFCTRL.REFCOMP=1
			-8.2	—	12.3	LSB	1 Msps, External VREF=2.4V, AVDD=VDD=3.3V, REFCTRL.REFCOMP=1
SADC_37	EOFF	Offset Error	-22.4	—	8.7	LSB	1 Msps, Internal VREF=AVDD=VDD=3.3V, SAMPCTRL.OFFCOMP=1
			-31.8	—	22.2	LSB	1 Msps, External VREF=2.4V, AVDD=VDD=3.3V, SAMPCTRL.OFFCOMP=1
SADC_43	TUE	Total Unadjusted Error	-18.3	—	18.3	LSB	1 Msps, Internal VREF=AVDD=VDD=3.3V, REFCTRL.REFCOMP=1, SAMPCTRL.OFFCOMP=1
SADC_47			-19.1	—	19.1	LSB	1 Msps, External VREF=2.4V, AVDD=VDD=3.3V, REFCTRL.REFCOMP=1, SAMPCTRL.OFFCOMP=1

**SINGLE ENDED MODE ADC Dynamic Performance <sup>(4)</sup>**

SADC_49	SINAD <sup>(1,2)</sup>	Signal to Noise and Distortion	55.7	—	—	dB	VREF=AVDD=VDD=3.3V at 12bit max sampling rate
SADC_51	SNR <sup>(1,2)</sup>	Signal to Noise ratio	54.7	—	—		
SADC_53	SFDR <sup>(1,2)</sup>	Spurious Free Dynamic Range	67.9	—	—		
SADC_55	THD <sup>(1,2,3)</sup>	Total Harmonic Distortion	—	—	-65.8		
SADC_57	Nrms	Noise RMS	—	—	2.2	LSB	VREF = AVDD = VDD = 3.3V, Constant Input Voltage
			—	—	3.6	LSB	External VREF = 2.4V, AVDD = VDD = 3.3V, Constant Input Voltage

**Notes:**

1. Characterized with an analog input sine wave = (FTP(max) / 100). Example: FTP(max)=1Msps/100 = 10kHz sine wave.
2. Sinewave peak amplitude = 96% ADC\_ Full Scale amplitude input with 12bit resolution.
3. Value taken over 7 harmonics.
4. ADC is configured in 12bits mode, All registers are at the reset default value unless otherwise stated.

**Table 55-27. ADC Differential Mode Electrical Specifications**

AC CHARACTERISTICS			Standard Operating Conditions: VDD = AVDD = 1.71V to 3.63V (unless otherwise stated) Operating temperature : -40°C ≤ T <sub>A</sub> ≤ +85°C for Industrial Temperature				
Param. No.	Symbol	Characteristics	Min.	Typ.	Max.	Units	Conditions
<b>DIFFERENTIAL MODE ADC Accuracy <sup>(4)</sup></b>							
DADC_11	Res	Resolution	8	—	12	bits	Selectable 8, 10, 12 bit Resolution Ranges

.....continued

AC CHARACTERISTICS			Standard Operating Conditions: VDD = AVDD = 1.71V to 3.63V (unless otherwise stated) Operating temperature : -40°C ≤ T <sub>A</sub> ≤ +85°C for Industrial Temperature				
Param. No.	Symbol	Characteristics	Min.	Typ.	Max.	Units	Conditions
DADC_13	ENOB <sup>(1,2)</sup>	Effective Number of bits	10.5	—	—	bits	1MSPS, Internal VREF=AVDD=VDD=3.3V
DADC_15			10.5	—	—	bits	1MSPS, External VREF=2.4V, AVDD=VDD=3.3V
DADC_19	INL	Integral Nonlinearity	-1.5	—	1.5	LSB	1MSPS, Internal VREF=AVDD=VDD=3.3V
DADC_21			-1.5	—	1.5	LSB	1MSPS, External VREF=2.4V, AVDD=VDD=3.3V
DADC_25	DNL	Differential Nonlinearity	-1	—	1	LSB	1MSPS, Internal VREF=AVDD=VDD=3.3V
DADC_27			-1	—	1	LSB	1MSPS, External VREF=2.4V, AVDD=VDD=3.3V
DADC_31	GERR	Gain Error	-7.4	—	6.6	LSB	1MSPS, Internal VREF=AVDD=VDD=3.3V, REFCTRL.REFCOMP=1
			-3.7	—	7.4	LSB	1MSPS, External VREF=2.4V, AVDD=VDD=3.3V, REFCTRL.REFCOMP=1
			-8.2	—	6.6	LSB	1MSPS, Internal VREF=AVDD=VDD=3.3V, REFCTRL.REFCOMP=0
			-30.4	—	27.1	LSB	1MSPS, External VREF=2.4V, AVDD=VDD=3.3V, REFCTRL.REFCOMP=0
DADC_37	EOFF	Offset Error	-3.6	—	3.0	LSB	1MSPS, Internal VREF=AVDD=VDD=3.3V, SAMPCTRL.OFFCOMP=1
			-4.5	—	3.6	LSB	1MSPS, External VREF=2.4V, AVDD=VDD=3.3V, SAMPCTRL.OFFCOMP=1
			-11.8	—	12.3	LSB	1MSPS, Internal VREF=AVDD=VDD=3.3V, SAMPCTRL.OFFCOMP=0
			-16.9	—	16.8	LSB	1MSPS, External VREF=2.4V, AVDD=VDD=3.3V, SAMPCTRL.OFFCOMP=0
DADC_43	TUE	Total Unadjusted Error	-5.2	—	5.2	LSB	1MSPS, Internal VREF=AVDD=VDD=3.3V, REFCTRL.REFCOMP=1, SAMPCTRL.OFFCOMP=1
DADC_45			-5.6	—	5.6	LSB	1MSPS, External VREF=2.4V, AVDD=VDD=3.3V, REFCTRL.REFCOMP=1, SAMPCTRL.OFFCOMP=1

**DIFFERENTIAL MODE ADC Dynamic Performance<sup>(4)</sup>**

.....continued

AC CHARACTERISTICS			Standard Operating Conditions: VDD = AVDD = 1.71V to 3.63V (unless otherwise stated) Operating temperature : -40°C ≤ T <sub>A</sub> ≤ +85°C for Industrial Temperature				
Param. No.	Symbol	Characteristics	Min.	Typ.	Max.	Units	Conditions
DADC_49	SINAD <sup>(1,2)</sup>	Signal to Noise and Distortion	65.3	—	—	dB	VREF=AVDD=VDD=3.3V at 12bit max sampling rate
DADC_51	SNR <sup>(1,2)</sup>	Signal to Noise ratio	64.7	—	—		
DADC_53	SFDR <sup>(1,2)</sup>	Spurious Free Dynamic Range	76.6	—	—		
DADC_55	THD <sup>(1,2,3)</sup>	Total Harmonic Distortion	—	—	-78.6		
DADC_57	Nrms	Noise RMS	—	—	3.1	LSB	VREF = AVDD = VDD = 3.3V, Constant Input Voltage
			—	—	4.1	LSB	External VREF = 2.4V, AVDD = VDD = 3.3V, Constant Input Voltage

**Notes:**

1. Characterized with an analog input sine wave = (FTP(max) / 100). Example: FTP(max)=1Msps/100 = 10kHz sine wave.
2. Sinewave peak amplitude = 96% ADC\_ Full Scale amplitude input with 12bit resolution.
3. Value taken over 7 harmonics.
4. ADC is configured in 12bits mode, All registers are at the reset default value unless otherwise stated.

**Table 55-28. ADC Conversion Electrical Requirements <sup>(2)</sup>**

AC CHARACTERISTICS			Standard Operating Conditions: VDD = AVDD = 1.71V to 3.63V (unless otherwise stated) Operating temperature: -40°C ≤ T <sub>A</sub> ≤ +85°C for Industrial Temperature				
Param. No.	Symbol	Characteristics	Min.	Typ.	Max.	Units	Conditions
<b>ADC_Clock Requirements</b>							
ADC_57	TAD	ADC Clock Period	62.5	—	6250	ns	—
ADC_58	fGCLK_ADCx	ADCx Module GCLK max input freq	—	—	FCLK_51	MHz	FCLK_51: Refer to <a href="#">Maximum Clock Frequencies Electrical Specifications</a>
<b>ADC Single-Ended Throughput Rates</b>							

.....continued

AC CHARACTERISTICS			Standard Operating Conditions: VDD = AVDD = 1.71V to 3.63V (unless otherwise stated) Operating temperature: -40°C ≤ T <sub>A</sub> ≤ +85°C for Industrial Temperature				
Param. No.	Symbol	Characteristics	Min.	Typ.	Max.	Units	Conditions
ADC_59	FTPR <sup>(1)</sup> (Single-Ended Mode)	Throughput Rate (Single-Ended)	12.31	—	1231	ksps	12-bit resolution, R <sub>source</sub> ≤ 147 Ω, SAMPCTRL.OFFCOMP=0, SAMPCTRL.SAMPLEN=0
			13.33	—	1333		10-bit resolution, R <sub>source</sub> ≤ 504 Ω, SAMPCTRL.OFFCOMP=0, SAMPCTRL.SAMPLEN=0
			16	—	1600		8-bit resolution, R <sub>source</sub> ≤ 1,000 Ω, SAMPCTRL.OFFCOMP=0, SAMPCTRL.SAMPLEN=0
			10	—	1000	ksps	12-bit resolution, R <sub>source</sub> ≤ 6,560 Ω SAMPCTRL.OFFCOMP=1, SAMPCTRL.SAMPLEN=n/a
			10.67	—	1067		10-bit resolution, R <sub>source</sub> ≤ 8,000 Ω SAMPCTRL.OFFCOMP=1, SAMPCTRL.SAMPLEN=n/a
			12.31	—	1231		8-bit resolution, R <sub>source</sub> ≤ 9,984 Ω SAMPCTRL.OFFCOMP=1, SAMPCTRL.SAMPLEN=n/a
<b>ADC Differential Mode Throughput Rates</b>							

.....continued

AC CHARACTERISTICS			Standard Operating Conditions: VDD = AVDD = 1.71V to 3.63V (unless otherwise stated) Operating temperature: -40°C ≤ T <sub>A</sub> ≤ +85°C for Industrial Temperature				
Param. No.	Symbol	Characteristics	Min.	Typ.	Max.	Units	Conditions
ADC_61	FTPR <sup>(1)</sup> (Differential Mode)	Throughput Rate (Differential Mode)	12.31	—	1231	ksps	12-bit resolution, R <sub>source</sub> ≤ 147 Ω, SAMPCTRL.OFFCOMP=0, SAMPCTRL.SAMPLEN=0
			14.55	—	1455		10-bit resolution, R <sub>source</sub> ≤ 504 Ω, SAMPCTRL.OFFCOMP=0, SAMPCTRL.SAMPLEN=0
			17.78	—	1778		8-bit resolution, R <sub>source</sub> ≤ 1,000 Ω, SAMPCTRL.OFFCOMP=0, SAMPCTRL.SAMPLEN=0
			10	—	1000	ksps	12-bit resolution, R <sub>source</sub> ≤ 6,560 Ω SAMPCTRL.OFFCOMP=1, SAMPCTRL.SAMPLEN=n/a
			11.43	—	1143		10-bit resolution, R <sub>source</sub> ≤ 8,000 Ω SAMPCTRL.OFFCOMP=1, SAMPCTRL.SAMPLEN=n/a
			13.33	—	1333		8-bit resolution, R <sub>source</sub> ≤ 9,984 Ω SAMPCTRL.OFFCOMP=1, SAMPCTRL.SAMPLEN=n/a

**Notes:**

- ADC Throughput Rate FTP = ((1 / ((TSAMP + TCNV) \* TAD)) / (# of user active analog inputs in use on specific target ADC module)).  
**Note:** Specification values assume only one AINx channel in use.
- These values are based on simulation, and not covered by production test limits or characterization.

**Table 55-29. ADC Sample Electrical Requirements** <sup>(3)</sup>

AC CHARACTERISTICS			Standard Operating Conditions: VDD = AVDD = 1.71V to 3.63V (unless otherwise stated) Operating temperature: -40°C ≤ T <sub>A</sub> ≤ +85°C for Industrial Temperature				
Param. No.	Symbol	Characteristics	Min.	Typ.	Max.	Units	Conditions
ADC_63	TSAMP	ADC Sample Time <sup>(1,2,4)</sup>	1	—	—	TAD	12 bit TAD(min), Ext Analog Input Rsource ≤ 147 Ω
							10 bit TAD(min), Ext Analog Input Rsource ≤ 504 Ω
							8 bit TAD(min), Ext Analog Input Rsource ≤ 1,000 Ω
			2	—	—		12 bit TAD(min), Ext Analog Input Rsource ≤ 2,272 Ω
							10 bit TAD(min), Ext Analog Input Rsource ≤ 3,008 Ω
							8 bit TAD(min), Ext Analog Input Rsource ≤ 4,000 Ω
			3	—	—		12 bit TAD(min), Ext Analog Input Rsource ≤ 4,416 Ω
							10 bit TAD(min), Ext Analog Input Rsource ≤ 5,504 Ω
							8 bit TAD(min), Ext Analog Input Rsource ≤ 6,976 Ω
			4	—	—		12 bit TAD(min), Ext Analog Input Rsource ≤ 6,560 Ω
							10 bit TAD(min), Ext Analog Input Rsource ≤ 8,000 Ω
							8 bit TAD(min), Ext Analog Input Rsource ≤ 9,984 Ω
			5	—	—		12 bit TAD(min), Ext Analog Input Rsource ≤ 8,704 Ω
							10 bit TAD(min), Ext Analog Input Rsource ≤ 10,496 Ω
							8 bit TAD(min), Ext Analog Input Rsource ≤ 12,992 Ω
			6	—	—		12 bit TAD(min), Ext Analog Input Rsource ≤ 10,880 Ω
							10 bit TAD(min), Ext Analog Input Rsource ≤ 12,992 Ω
							8 bit TAD(min), Ext Analog Input Rsource ≤ 16,000 Ω
							DS60001715G - 1758
							With DAC as input DAC_15, DAC_17: Refer to DACM Data Sheet
							ns

.....continued

AC CHARACTERISTICS			Standard Operating Conditions: VDD = AVDD = 1.71V to 3.63V (unless otherwise stated) Operating temperature: -40°C ≤ T <sub>A</sub> ≤ +85°C for Industrial Temperature				
Param. No.	Symbol	Characteristics	Min.	Typ.	Max.	Units	Conditions
ADC_65	TCNV	Conversion Time (Single-Ended Mode)	12			TAD	12-bit resolution
			11				10-bit resolution
			9				8-bit resolution
ADC_67	TCNV	Conversion Time (Differential Mode)	12			TAD	12-bit resolution
			10				10-bit resolution
			8				8-bit resolution
ADC_69	CSAMPLE	ADC Internal Sample Cap	—	—	3	pF	—
ADC_71	RSAMPLE	ADC Internal impedance	—	—	2000	Ω	—

**Notes:**

- When SAMPCTRL.OFFCOMP = 0:
  - TSAMP = (((RSAMPLE + RSOURCE) \* CSAMPLE \* (#Bits Resolution + 2) \* ln(2)) / TAD)+1 rounded down to nearest whole integer
  - User SAMPCTRL.SAMPLEN = (TSAMP - 1)
- When SAMPCTRL.OFFCOMP=1:
  - TSAMP = 4 (Forced by HDW)
  - User SAMPCTRL.SAMPLEN = (n/a, Ignored by HDW)
- These values are based on simulation and are not covered by production test limits or characterization.
- TSAMP ≥ (INT[(((RSAMPLE + RSOURCE) \* CSAMPLE \* (#Bits Resolution+2) \* ln(2)) / TAD]+1).

## 55.23 AC Electrical Specifications

Table 55-30. Comparator Electrical Specifications

AC CHARACTERISTICS			Standard Operating Conditions: VDD = AVDD = 1.71V to 3.63V (unless otherwise stated) Operating temperature: -40°C ≤ T <sub>A</sub> ≤ +85°C for Industrial Temperature					
Param. No.	Symbol	Characteristics	Min.	Typ.	Max.	Units	Conditions	
CMP_1	VIOFF	Input Offset Voltage	-14	—	14	mV	COMPCTRLn.SPEED = 0x3	
			-20	—	20		COMPCTRLn.SPEED = 0x0	
CMP_4	VIN	Input Voltage Range	AVSS	—	AVDD	V	With respect to AVSS and AVDD	
CMP_5	VHYST_00	Input Hysteresis Voltage	13	—	46	mV	COMPCTRLn.SPEED = 0x3 COMPCTRLn.HYSTEN = 0x1 COMPCTRLn.HYST = 0x0	
			5	—	40	mV	COMPCTRLn.SPEED = 0x0 COMPCTRLn.HYSTEN = 0x1 COMPCTRLn.HYST = 0x0	
	VHYST_01	Input Hysteresis Voltage	30	—	71	mV	COMPCTRLn.SPEED = 0x3 COMPCTRLn.HYSTEN = 0x1 COMPCTRLn.HYST = 0x1	
			20	—	59	mV	COMPCTRLn.SPEED = 0x0 COMPCTRLn.HYSTEN = 0x1 COMPCTRLn.HYST = 0x1	
	VHYST_02	Input Hysteresis Voltage	39	—	101	mV	COMPCTRLn.SPEED = 0x3 COMPCTRLn.HYSTEN = 0x1 COMPCTRLn.HYST = 0x2	
			33	—	84	mV	COMPCTRLn.SPEED = 0x0 COMPCTRLn.HYSTEN = 0x1 COMPCTRLn.HYST = 0x2	
	VHYST_03	Input Hysteresis Voltage	64	—	132	mV	COMPCTRLn.SPEED = 0x3 COMPCTRLn.HYSTEN = 0x1 COMPCTRLn.HYST = 0x3	
			46	—	110	mV	COMPCTRLn.SPEED = 0x0 COMPCTRLn.HYSTEN = 0x1 COMPCTRLn.HYST = 0x3	
	CMP_15	TRESP <sub>SS</sub> <sup>(2)</sup>	Small Signal Response Time - High speed	—	—	39	ns	COMPCTRLn.SPEED = 0x3 COMPCTRLn.HYSTEN = 0x0 Comparator ref voltage = AVDD/2. Input overdrive = +/- 100mV
			Small Signal Response Time - Low Speed	—	—	92	ns	COMPCTRLn.SPEED = 0x0 COMPCTRLn.HYSTEN = 0x0 Comparator ref voltage = AVDD/2. Input overdrive = +/- 100mV
CMP_19	C <sub>OUTVAL</sub>	Comparator Enabled to Output Valid - High Speed	—	—	7	ms	Comparator module is configured before enabling it COMPCTRLn.SPEED = 0x3	
		Comparator Enabled to Output Valid - Low Speed	—	—	13.5	ms	Comparator module is configured before enabling it COMPCTRLn.SPEED = 0x0	
CMP_21	AC <sub>IREF</sub>	Comparator Internal Band Gap Voltage Reference	VR_9			V	VR_9: Refer to <a href="#">Internal Voltage Reference Specifications</a> .	



.....continued

AC CHARACTERISTICS			Standard Operating Conditions: VDD = AVDD = 1.71V to 3.63V (unless otherwise stated) Operating temperature: -40°C ≤ T <sub>A</sub> ≤ +85°C for Industrial Temperature				
Param. No.	Symbol	Characteristics	Min.	Typ.	Max.	Units	Conditions
CMP_23	C <sub>VREFRNG</sub>	Comparator Voltage Reference Input Range	-2	—	AVDD - 0.2V or Note <sup>(1)</sup> , whichever is lower	V	-
CMP_25	F <sub>GCLK_AC</sub>	Analog comparator peripheral module clock freq	—	—	FCLK_49	MHz	FCLK_49: Refer to <a href="#">Maximum Clock Frequencies Electrical Specifications</a>

**Notes:**

- Comparator Ref voltage cannot exceed: (VIN(max) - VIOFF(max) - CMP\_5(max) - 50mV) ≥ C<sub>VREFRNG</sub> ≥ (VIN(min) + abs(VIOFF(min)) + CMP\_5(max) + 50mV).
- TRESP<sub>SS</sub> is measured from VIN transition to ACOUT toggle (AC direct output accessible by setting COMPCTRLn.OUT[1:0]=0x1). It takes into account only analog propagation delay.

## 55.24 PTC Electrical Specifications

**Table 55-31.** Peripheral Touch Controller Electrical Specifications <sup>(3)</sup>

AC CHARACTERISTICS			Standard Operating Conditions: VDD = AVDD = 1.71V to 3.63V (unless otherwise stated) Operating temperature: -40°C ≤ T <sub>A</sub> ≤ +85°C for Industrial Temperature					
Param. No.	Symbol	Characteristics	Min.	Typ.	Max.	Units	Conditions	
PTC_1	CLOAD SC <sup>(1)</sup>	Self Capacitance Mode (PTC Channel Y0 - Y31)	—	—	51	pF	User maximum sensor external load capacitance	
PTC_3	CLOAD MC <sup>(1)</sup>	Mutual Capacitance Mode (PTC Channel Y0 - Y31)	—	—	31	pF		
<b>PTC ANALOG GAIN SETTINGS <sup>(2)</sup></b>								
PTC_5	PTC <sub>GAIN</sub>	Analog Gain Settings	Gain_1	—	1	—	—	—
			Gain_2	—	2	—		
			Gain_4	—	4.2	—		
			Gain_8	—	9.1	—		
<b>Notes:</b>								
<ol style="list-style-type: none"> <li>Maximum capacitive load that the PTC circuitry can compensate for each channel.</li> <li>Analog Gain is a parameter of the Touch Library. Refer to the <i>Touch Library Peripheral Touch Controller User Guide</i> on the Microchip website.</li> <li>AVDD = 3.3V, DFLL48M as main clock source, running undivided at 48 MHz. CPU is running on Flash with 2 wait states, at 48 MHz. PTC running at 4 MHz. Mutual-Capacitance mode. One touch channel. Standby Sleep mode enabled. RTC running on ULP32K: used to define the PTC scan rate, through the event system. RTC interrupts (wake up) the CPU to perform PTC scans.</li> </ol>								

## 55.25 SPI Electrical Specifications

Figure 55-1. SPI Host Module (CPHA = 0) Timing Diagrams

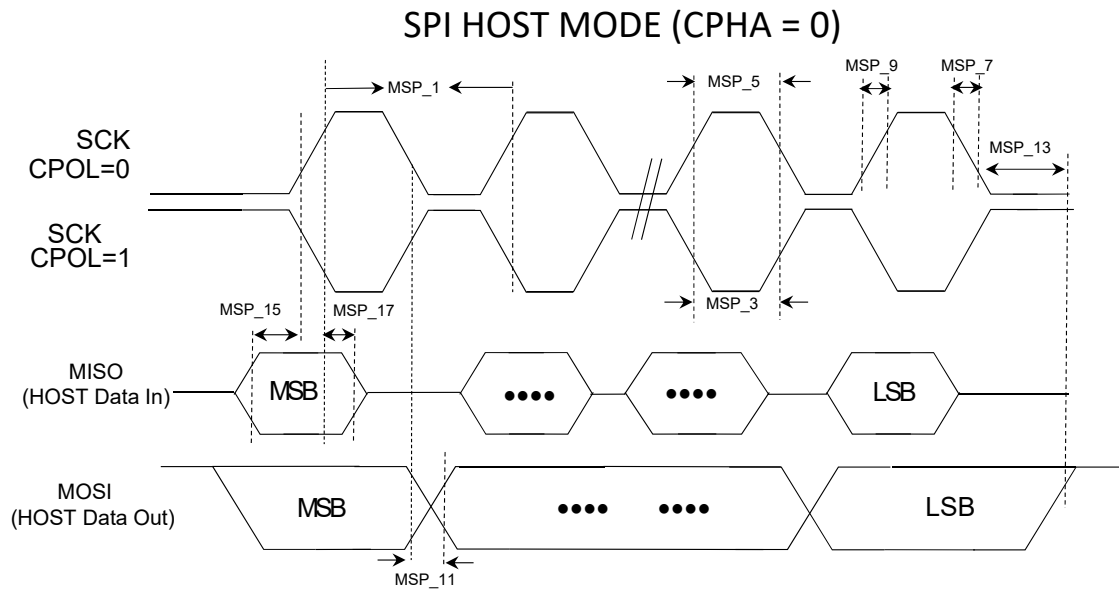
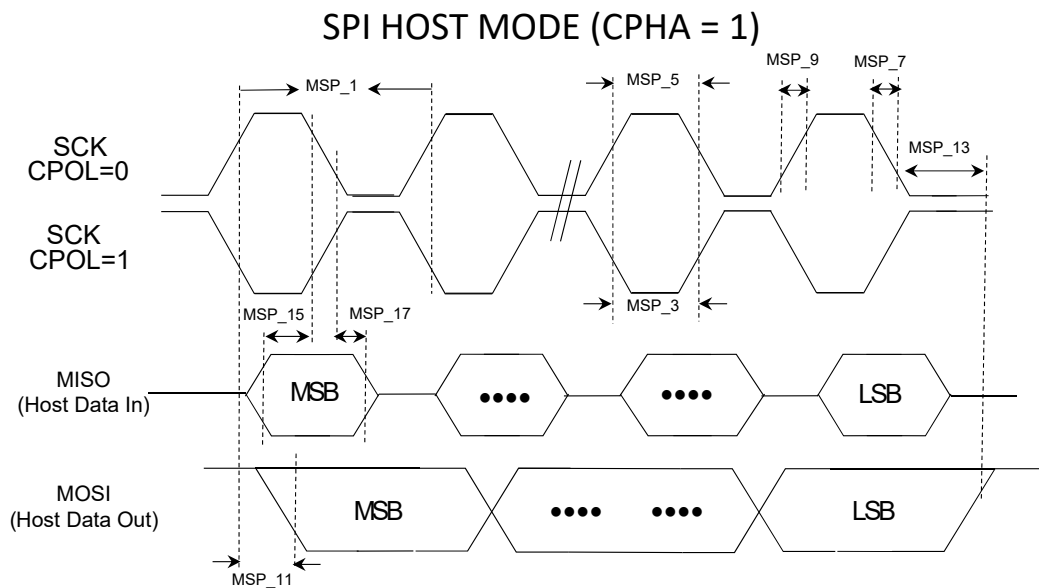


Figure 55-2. SPI Host Module (CPHA = 1) Timing Diagrams



**Table 55-32. SPI Module Host Mode Electrical Specifications** <sup>(1)</sup>

AC CHARACTERISTICS			Standard Operating Conditions: VDD = AVDD = 1.71V to 3.63V (unless otherwise stated) Operating temperature: -40°C ≤ T <sub>A</sub> ≤ +85°C for Industrial Temperature				
Param. No.	Symbol	Characteristics	Min.	Typ.	Max.	Units	Conditions
MSP_1	FSCK	SCK Frequency	—	—	15	MHz	VDD = 1.8V, C <sub>LOAD</sub> = 20 pF <sub>(MAX)</sub>
			—	—	20	MHz	VDD = 3.3V, C <sub>LOAD</sub> = 20pF <sub>(MAX)</sub>
MSP_3	TSCL	SCK Output Low Time	1/(2*FSCK)	—	—	ns	—
MSP_5	TSCH	SCK Output High Time	1/(2*FSCK)	—	—	ns	—
MSP_7	TSCF	SCK & MOSI Output Fall Time	—	—	DI_27	ns	DI_27: Refer to <a href="#">I/O Pin Electrical Specifications</a>
MSP_9	TSCR	SCK & MOSI Output Rise Time	—	—	DI_25	ns	DI_25: Refer to <a href="#">I/O Pin Electrical Specifications</a>
MSP_11	TMOV	MOSI Data Output Valid after SCK	—	—	9	ns	VDD(min), C <sub>LOAD</sub> = 20pF <sub>(MAX)</sub>
MSP_13	TMOH	MOSI hold after SCK	0	—	—	ns	
MSP_15	TMIS	MISO Setup Time of Data Input to SCK	18	—	—	ns	
MSP_17	TMIH	MISO Hold Time of Data Input to SCK	0	—	—	ns	
MSP_19	SPI_GCLK	SERCOM SPI input clock freq, GCLK_SPI	—	—	FCLK_23	MHz	FCLK_23: Refer to <a href="#">Maximum Clock Frequencies Electrical Specifications</a>

**Note:**  
1. Assumes VDD(min) and 20 pF external load on all SPIx pins unless otherwise noted.

Figure 55-3. SPI Client Module (CPHA = 0) Timing Diagrams

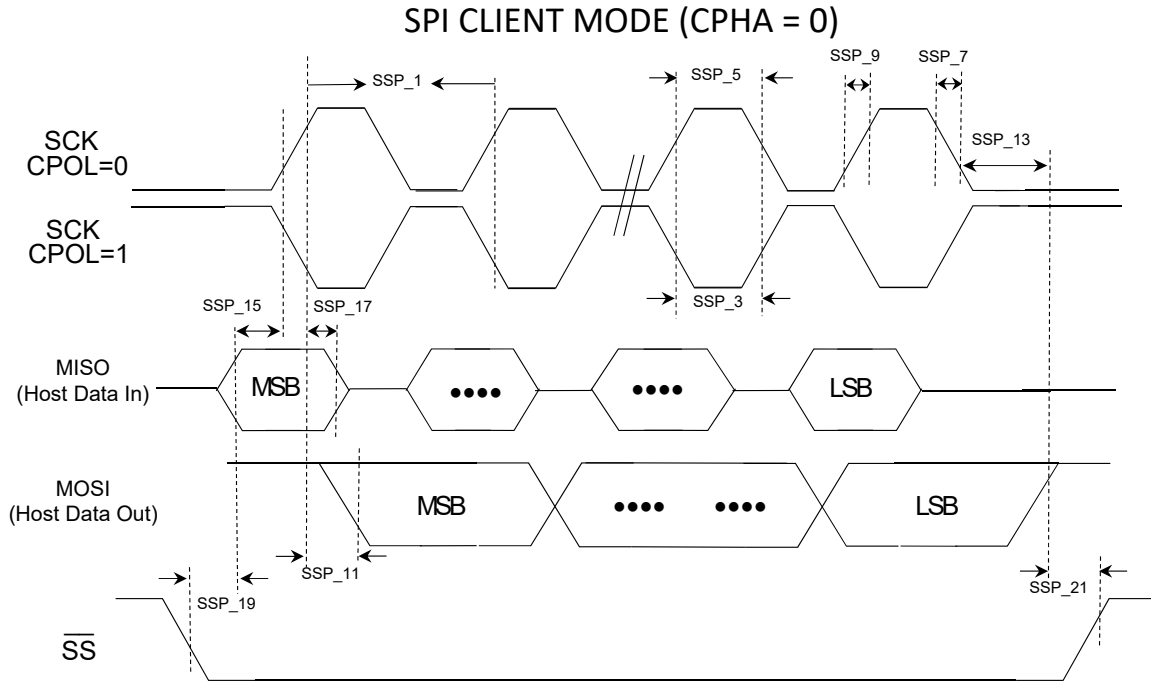
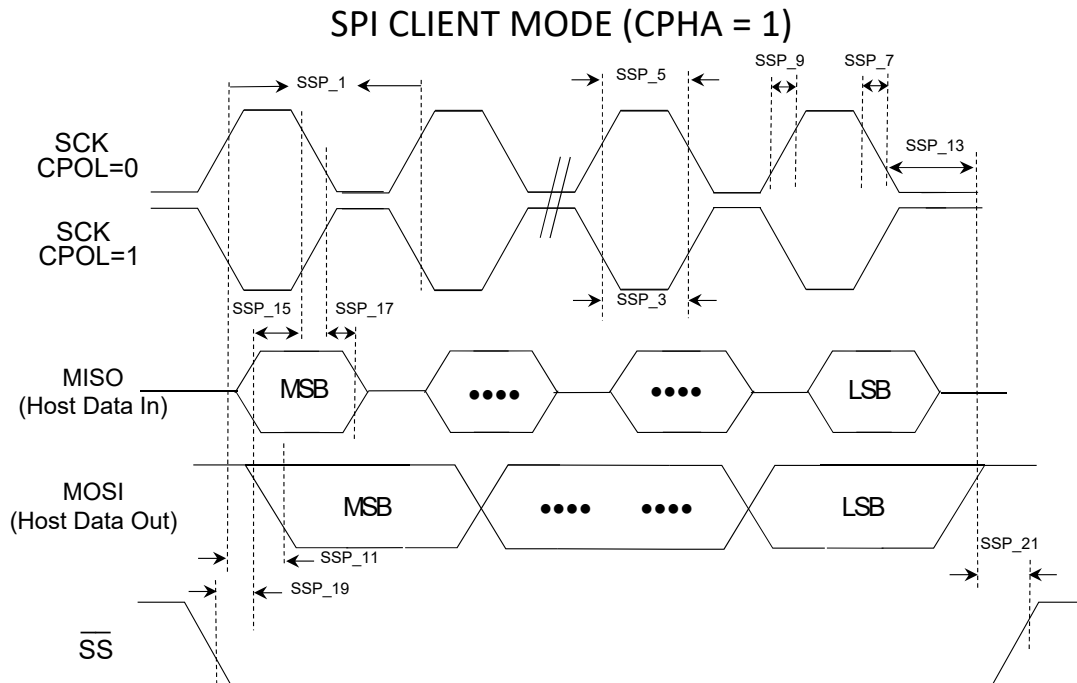


Figure 55-4. SPI Client Module (CPHA = 1) Timing Diagrams



**Table 55-33. SPI Module Client Mode Electrical Specifications <sup>(1)</sup>**

AC CHARACTERISTICS			Standard Operating Conditions: VDD = AVDD = 1.71V to 3.63V (unless otherwise stated) Operating temperature: -40°C ≤ T <sub>A</sub> ≤ +85°C for Industrial Temperature				
Param. No.	Symbol	Characteristics	Min.	Typ.	Max.	Units	Conditions
SSP_1	FSCK	SCK Frequency	—	—	15	MHz	VDD=1.8V, C <sub>LOAD</sub> =20pF <sub>(MAX)</sub>
			—	—	20	MHz	VDD=3.3V, C <sub>LOAD</sub> =20pF <sub>(MAX)</sub>
SSP_3	TSCL	SCK Output Low Time	1/(2*FSCK)	—	—	ns	—
SSP_5	TSCH	SCK Output High Time	1/(2*FSCK)	—	—	ns	—
SSP_7	TSCF	SCK & MOSI Output Fall Time	—	—	DI_27	ns	DI_27: Refer to <a href="#">I/O Pin Electrical Specifications</a>
SSP_9	TSCR	SCK & MOSI Output Rise Time	—	—	DI_25	ns	DI_25: Refer to <a href="#">I/O Pin Electrical Specifications</a>
SSP_11	TSOV	MOSI Data Output Valid after SCK	—	—	15.7	ns	VDD(min), C <sub>LOAD</sub> =20pF <sub>(MAX)</sub> FCLK_5: Refer to <a href="#">Maximum Clock Frequencies Electrical Specifications</a>
SSP_13	TSOH	MOSI hold after SCK	0	—	—	ns	
SSP_15	TSIS	MISO Setup Time of Data Input to SCK	7.5	—	—	ns	
SSP_17	TSIH	MISO Hold Time of Data Input to SCK	4	—	—	ns	
SSP_19	TSSS	$\overline{SS}$ setup to SCK (PRELOADEN=1)	(2/FCLK_5)+(1/FSCK)	—	—	ns	
		$\overline{SS}$ setup to SCK (PRELOADEN=0)	1/FSCK	—	—	ns	
SSP_21	TSSH	$\overline{SS}$ hold after SCK Client	1/(2*FSCK)	—	—	ns	
SSP_23	SPI_GCLK	SERCOM SPI input clock freq, GCLK_SPI	—	—	FCLK_23	MHz	FCLK_23: Refer to <a href="#">Maximum Clock Frequencies Electrical Specifications</a>

**Note:**  
1. Assumes VDD(min) and 20 pF external load on all SPI pins unless otherwise noted.

## 55.26 USART Electrical Specifications

**Table 55-34.** USART Electrical Specifications

AC CHARACTERISTICS				Standard Operating Conditions: VDD = AVDD = 1.71V to 3.63V (unless otherwise stated) Operating temperature: -40°C ≤ T <sub>A</sub> ≤ +85°C for Industrial Temperature				
Param. No.	Symbol	Characteristics		Min.	Typ.	Max.	Units	Conditions
UT_1	F <sub>BRATE</sub>	Baud Rate	Asynchronous SAMPR = 16x mode	—	—	FCLK_23/16	Mbps	VDD=1.8V or VDD=3.3V FCLK_23: Refer to <a href="#">Maximum Clock Frequencies Electrical Specifications</a>
UT_3			Asynchronous SAMPR = 8x mode	—	—	FCLK_23/8	Mbps	VDD=1.8V or VDD=3.3V FCLK_23: Refer to <a href="#">Maximum Clock Frequencies Electrical Specifications</a>
UT_5			Asynchronous SAMPR = 3x mode	—	—	FCLK_23/3	Mbps	VDD=1.8V or VDD=3.3V FCLK_23: Refer to <a href="#">Maximum Clock Frequencies Electrical Specifications</a>
UT_19			Synchronous Host Mode (internal clock)	—	—	7.5 10	Mbps	VDD=1.8V VDD=3.3V
UT_21			Synchronous Client Mode (external clock)	—	—	15 20		Mbps
UT_23	F <sub>USART</sub>	USART max GCLK_SERCOM		—	—	FCLK_23	MHz	
UT_25	F <sub>XCK</sub>	USART External Clock Input		—	—	FCLK_45	MHz	FCLK_45: Refer to <a href="#">Maximum Clock Frequencies Electrical Specifications</a>
<b>Note:</b>								
1. These parameters are characterized, but not tested in manufacturing.								

## 55.27 I<sup>2</sup>S Electrical Specifications

Figure 55-5. I<sup>2</sup>S Host Mode Timing Diagram

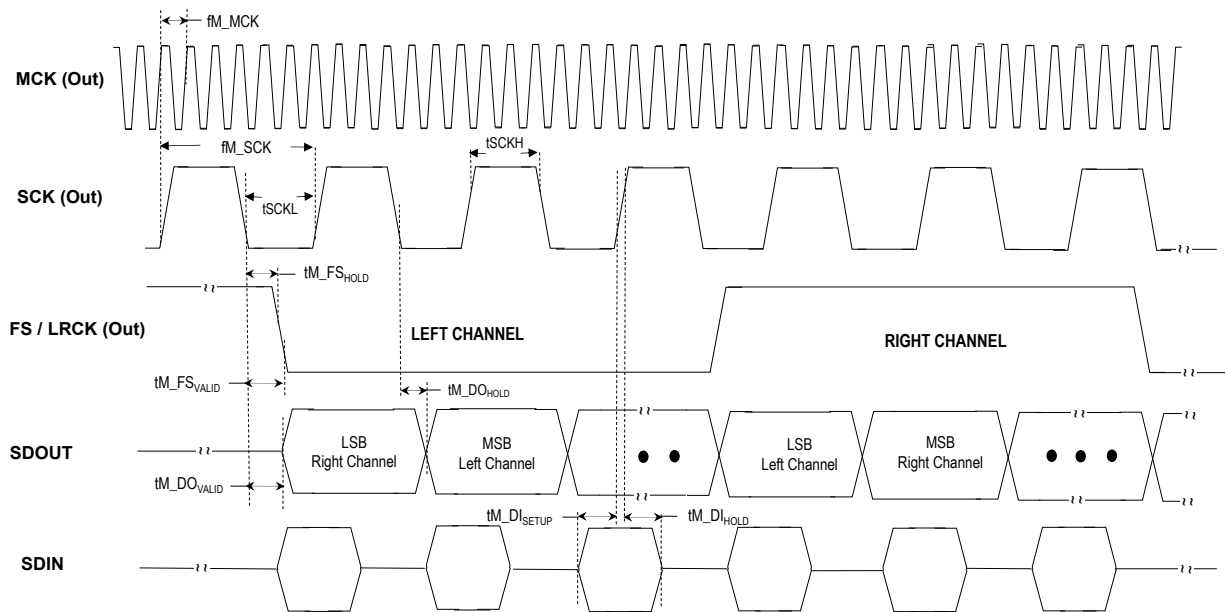


Table 55-35. I<sup>2</sup>S Host Mode Electrical Specifications

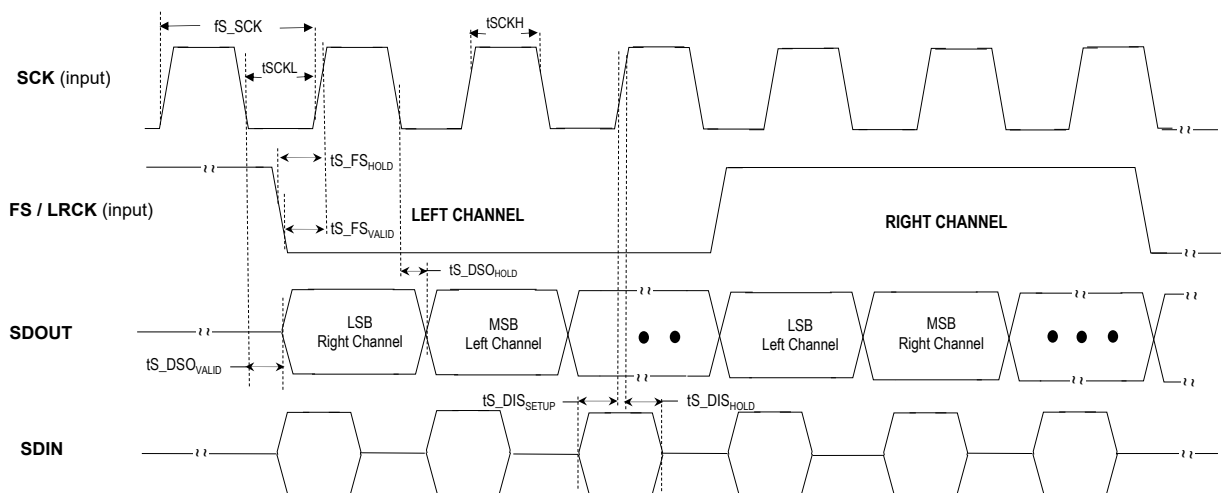
AC CHARACTERISTICS			Standard Operating Conditions: VDD = AVDD = 1.71V to 3.63V (unless otherwise stated) Operating temperature: -40°C ≤ T <sub>A</sub> ≤ +85°C for Industrial Temperature				
Param. No.	Symbol	Characteristics	Min.	Typ.	Max.	Units	Conditions
I2S_1	f <sub>M_MCK</sub>	Host MCK Frequency	—	—	12.5	MHz	VDD = 1.8V or VDD(min.) whichever is greater, C <sub>LOAD</sub> = 20 pF(max.)
					12.5		VDD = 3.3V, C <sub>LOAD</sub> = 20 pF(max.)
I2S_3	t <sub>MCKL</sub>	MCK Output Low Time	1/(2*f <sub>M_MCK</sub> )	—	—	ns	—
I2S_5	t <sub>MCKH</sub>	MCK Output High Time	1/(2*f <sub>M_MCK</sub> )	—	—	ns	—
I2S_7	t <sub>MCKR</sub>	MCK Rise Time		DI_25		ns	DI_25: Refer to <a href="#">I/O Pin Electrical Specifications</a>
I2S_9	t <sub>MCKF</sub>	MCK Fall Time		DI_27		ns	DI_27: Refer to <a href="#">I/O Pin Electrical Specifications</a>
I2S_11	f <sub>M_SCK</sub>	Host SCK Frequency	—	—	10.29	MHz	VDD = 1.8V or VDD(min.) whichever is greater, C <sub>LOAD</sub> = 20 pF(max.)
					11.4		VDD = 3.3V, C <sub>LOAD</sub> = 20 pF(max.)
I2S_13	t <sub>SCKL</sub>	SCK Output Low Time	1/(2*f <sub>M_SCK</sub> )	—	—	ns	—
I2S_15	t <sub>SCKH</sub>	SCK Output High Time	1/(2*f <sub>M_SCK</sub> )	—	—	ns	—
I2S_17	t <sub>SCKR</sub>	SCK Rise Time		DI_25		ns	DI_25: Refer to <a href="#">I/O Pin Electrical Specifications</a>
I2S_19	t <sub>SCKF</sub>	SCK Fall Time		DI_27		ns	DI_27: Refer to <a href="#">I/O Pin Electrical Specifications</a>
I2S_21	t <sub>M_FSVALID</sub>	Host Frame Sync Valid	—	—	5.3	ns	VDD = 1.8V or VDD(min.) whichever is greater, C <sub>LOAD</sub> = 20 pF(max.)
			—	—	4.2	ns	VDD = 3.3V, C <sub>LOAD</sub> = 20 pF(max)



.....continued

AC CHARACTERISTICS			Standard Operating Conditions: VDD = AVDD = 1.71V to 3.63V (unless otherwise stated) Operating temperature: -40°C ≤ T <sub>A</sub> ≤ +85°C for Industrial Temperature				
Param. No.	Symbol	Characteristics	Min.	Typ.	Max.	Units	Conditions
I2S_23	t <sub>M_FSHOLD</sub>	Host Frame Sync Hold	0	—	—	ns	VDD = 1.8V or VDD(min.) whichever is greater, C <sub>LOAD</sub> = 20 pF(max.)
			0	—	—	ns	VDD = 3.3V, C <sub>LOAD</sub> = 20 pF(max.)
I2S_25	t <sub>M_DISETUP</sub>	Host Data Input Setup	16.4	—	—	ns	VDD = 1.8V or VDD(min.) whichever is greater, C <sub>LOAD</sub> = 20 pF(max.)
			11.9	—	—	ns	VDD = 3.3V, C <sub>LOAD</sub> = 20 pF(max.)
I2S_27	t <sub>M_DIHOLD</sub>	Host Data Input Hold	3.4	—	—	ns	VDD = 1.8V or VDD(min.) whichever is greater, C <sub>LOAD</sub> = 20 pF(max.)
			3.4	—	—	ns	VDD = 3.3V, C <sub>LOAD</sub> = 20 pF(max.)
I2S_29	t <sub>M_DOVALID</sub>	Host Data Output Valid	—	—	3.7	ns	VDD = 1.8V or VDD(min.) whichever is greater, C <sub>LOAD</sub> = 20 pF(max.)
			—	—	3	ns	VDD = 3.3V, C <sub>LOAD</sub> = 20 pF(max.)
I2S_31	t <sub>M_DOHOLD</sub>	Host Data Output Hold	0	—	—	ns	VDD = 1.8V or VDD(min.) whichever is greater, C <sub>LOAD</sub> = 20 pF(max.)
			0	—	—	ns	VDD = 3.3V, C <sub>LOAD</sub> = 20 pF(max.)
I2S_33	f <sub>GCLK_I2S</sub>	I <sup>2</sup> S Max GLK Input Clock Freq	—	—	FCLK_29	MHz	FCLK_29: Refer to <a href="#">Maximum Clock Frequencies Electrical Specifications</a>

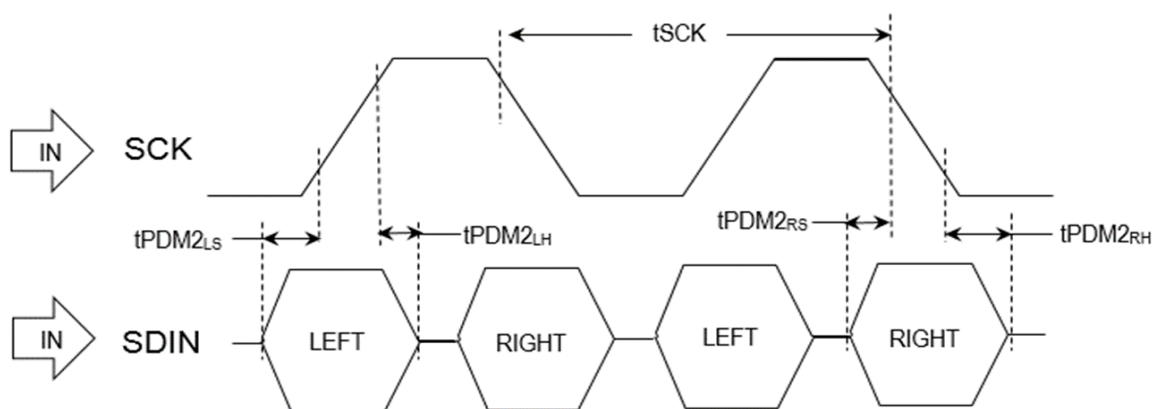
Figure 55-6. I<sup>2</sup>S Client Mode Timing Diagram



**Table 55-36. I<sup>2</sup>S Client Mode Electrical Specifications**

AC CHARACTERISTICS			Standard Operating Conditions: VDD = AVDD = 1.71V to 3.63V (unless otherwise stated) Operating temperature: -40°C ≤ T <sub>A</sub> ≤ +85°C for Industrial Temperature					
Param. No.	Symbol	Characteristics	Min.	Typ.	Max.	Units	Conditions	
I2S_41	f <sub>S_SCK</sub>	SCK Client Frequency	—	—	15.48	MHz	VDD=1.8V or VDD(min) whichever is greater, C <sub>LOAD</sub> =20pF(MAX)	
			—	—	15.83		VDD=3.3V, C <sub>LOAD</sub> =20pF(MAX)	
I2S_43	t <sub>S_FSVALID</sub>	Frame Sync Valid	4.1	—	—	ns	VDD=1.8V or VDD(min) whichever is greater, C <sub>LOAD</sub> =20pF(MAX)	
			3.8	—	—	ns	VDD=3.3V, C <sub>LOAD</sub> =20pF(MAX)	
I2S_45	t <sub>S_FSHOLD</sub>	Frame Sync Hold	0	—	—	ns	VDD=1.8V or VDD(min) whichever is greater, C <sub>LOAD</sub> =20pF(MAX)	
			0	—	—	ns	VDD=3.3V, C <sub>LOAD</sub> =20pF(MAX)	
I2S_47	t <sub>S_DISSETUP</sub>	Data Input Client Setup	2.8	—	—	ns	VDD=1.8V or VDD(min) whichever is greater, C <sub>LOAD</sub> =20pF(MAX)	
			2.1	—	—	ns	VDD=3.3V, C <sub>LOAD</sub> =20pF(MAX)	
I2S_49	t <sub>S_DISHOLD</sub>	Data Input Client Hold	0	—	—	ns	VDD=1.8V or VDD(min) whichever is greater, C <sub>LOAD</sub> =20pF(MAX)	
			0	—	—	ns	VDD=3.3V, C <sub>LOAD</sub> =20pF(MAX)	
I2S_51	t <sub>S_DSOVALID</sub>	Data Output Client Valid	—	—	16.9	ns	VDD=1.8V or VDD(min) whichever is greater, C <sub>LOAD</sub> =20pF(MAX)	
			—	—	12.3	ns	VDD=3.3V, C <sub>LOAD</sub> =20pF(MAX)	
I2S_53	t <sub>S_DSOHOLD</sub>	Data Output Client Hold	5.3	—	—	ns	VDD=1.8V or VDD(min) whichever is greater, C <sub>LOAD</sub> =20pF(MAX)	
			4.1	—	—	ns	VDD=3.3V, C <sub>LOAD</sub> =20pF(MAX)	

**Figure 55-7. I<sup>2</sup>S PDM2 Mode Timing Diagram**



**Table 55-37. I<sup>2</sup>S PMD2 Mode Electrical Specifications**

AC CHARACTERISTICS			Standard Operating Conditions: VDD = AVDD = 1.71V to 3.63V (unless otherwise stated) Operating temperature: -40°C ≤ T <sub>A</sub> ≤ +85°C for Industrial Temperature					
Param. No.	Symbol	Characteristics	Min.	Typ.	Max.	Units	Conditions	
I2S_55	t <sub>SCK</sub>	SCK Frequency	—	—	41.9	MHz	VDD=1.8V or VDD(min) whichever is greater, C <sub>LOAD</sub> =20pF(MAX)	
			—	—	44.5		VDD=3.3V, C <sub>LOAD</sub> =20pF(MAX)	
I2S_57	t <sub>PDM2LS</sub>	PDM Left Channel Setup	16.4	—	—	ns	VDD=1.8V or VDD(min) whichever is greater, C <sub>LOAD</sub> =20pF(MAX)	
			11.9	—	—	ns	VDD=3.3V, C <sub>LOAD</sub> =20pF(MAX)	
I2S_59	t <sub>PDM2LH</sub>	PDM Left Channel Hold	3.4	—	—	ns	VDD=1.8V or VDD(min) whichever is greater, C <sub>LOAD</sub> =20pF(MAX)	
			3.4	—	—	ns	VDD=3.3V, C <sub>LOAD</sub> =20pF(MAX)	
I2S_61	t <sub>PDM2RS</sub>	PDM Right Channel Setup	15.6	—	—	ns	VDD=1.8V or VDD(min) whichever is greater, C <sub>LOAD</sub> =20pF(MAX)	
			11.8	—	—	ns	VDD=3.3V, C <sub>LOAD</sub> =20pF(MAX)	
I2S_63	t <sub>PDM2RH</sub>	PDM Right Channel Hold	4.4	—	—	ns	VDD=1.8V or VDD(min) whichever is greater, C <sub>LOAD</sub> =20pF(MAX)	
			3.4	—	—	ns	VDD=3.3V, C <sub>LOAD</sub> =20pF(MAX)	

## 55.28 I<sup>2</sup>C Electrical Specifications

Figure 55-8. I<sup>2</sup>C Start/Stop Bits Host Mode Timing Diagrams

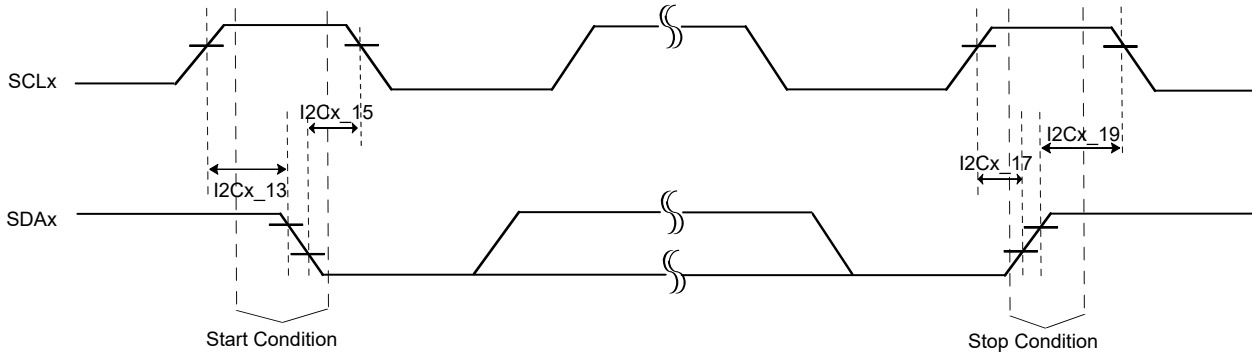


Figure 55-9. I<sup>2</sup>C Bus Data Host Mode Timing Diagrams

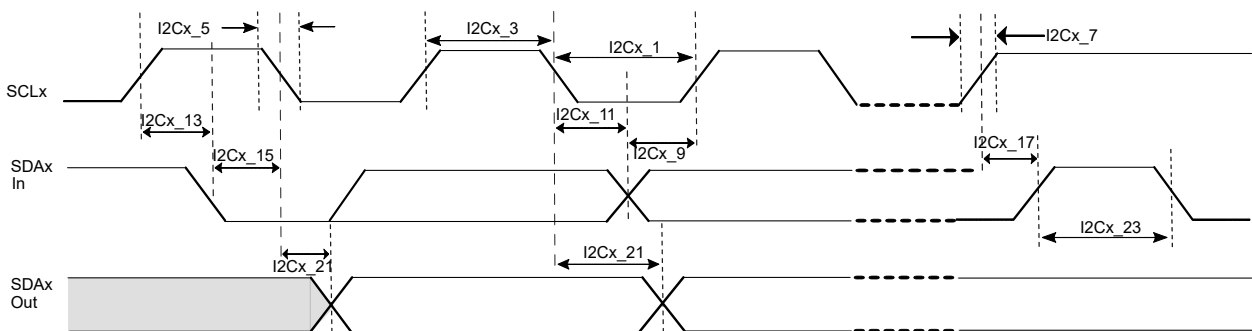


Table 55-38. I<sup>2</sup>C Host Mode Electrical Specifications

AC CHARACTERISTICS				Standard Operating Conditions: VDD = AVDD = 1.71V to 3.63V (unless otherwise stated) Operating temperature: -40°C ≤ T <sub>A</sub> ≤ +85°C for Industrial Temperature			
Param. No.	Symbol	Characteristics		Min.	Max.	Units	Conditions
I2CM_1	TLO:SCL	Host Clock Low Time	100 kHz mode	4.7	—	μs	VDD=3.3V, IPULLUP = 3mA, C <sub>LOAD</sub> =400pF
			400 kHz mode	1.3	—	μs	
			1 MHz mode	0.5	—	μs	
			3.4 MHz mode	160	—	ns	
I2CM_3	THI:SCL	Host Clock High Time	100 kHz mode	4.0	—	μs	VDD=3.3V, IPULLUP = 3mA, C <sub>LOAD</sub> =400pF
			400 kHz mode	0.6	—	μs	
			1 MHz mode	0.26	—	μs	
			3.4 MHz mode	60	—	ns	

.....continued

AC CHARACTERISTICS				Standard Operating Conditions: VDD = AVDD = 1.71V to 3.63V (unless otherwise stated) Operating temperature: -40°C ≤ T <sub>A</sub> ≤ +85°C for Industrial Temperature			
Param. No.	Symbol	Characteristics	Min.	Max.	Units	Conditions	
I2CM_5	TF:SCL	SDAx and SCLx Fall Time	100 kHz mode	—	300	ns	VDD=3.3V, IPULLUP = 3mA, C <sub>LOAD</sub> =400pF
			400 kHz mode	—	300	ns	
			1 MHz mode	—	120	ns	
			3.4 MHz mode	—	40	ns	
I2CM_7	TR:SCL	SDAx and SCLx Rise Time	100 kHz mode	—	1000	ns	VDD=3.3V, IPULLUP = 3mA, C <sub>LOAD</sub> =400pF
			400 kHz mode	—	300	ns	
			1 MHz mode	—	120	ns	
			3.4 MHz mode	—	40	ns	
I2CM_9	TSU:DAT	Data Setup Time	100 kHz mode	250	—	ns	VDD=3.3V, IPULLUP = 3mA, C <sub>LOAD</sub> =400pF
			400 kHz mode	100	—	ns	
			1 MHz mode	50	—	ns	
			3.4 MHz mode	10	—	ns	
I2CM_11	THD:DAT	Data Hold Time <sup>(1)</sup>	100 kHz mode	300	—	ns	VDD=3.3V, IPULLUP = 3mA, C <sub>LOAD</sub> =400pF
			400 kHz mode	300	—	ns	
			1 MHz mode	300	—	ns	
			3.4 MHz mode	5	—	ns	
I2CM_13	TSU:STA	Start Condition Setup Time	100 kHz mode	4.7	—	μs	VDD=3.3V, IPULLUP = 3mA, C <sub>LOAD</sub> =400pF
			400 kHz mode	0.6	—	μs	
			1 MHz mode	0.26	—	μs	
			3.4 MHz mode	160	—	ns	

.....continued

AC CHARACTERISTICS				Standard Operating Conditions: VDD = AVDD = 1.71V to 3.63V (unless otherwise stated) Operating temperature: -40°C ≤ T <sub>A</sub> ≤ +85°C for Industrial Temperature				
Param. No.	Symbol	Characteristics	Min.	Max.	Units	Conditions		
I2CM_15	THD:STA	Start Condition Hold Time	100 kHz mode	4.0	—	μs	VDD=3.3V, IPULLUP = 3mA, C <sub>LOAD</sub> =400pF	
			400 kHz mode	0.6	—	μs		
			1 MHz mode	0.26	—	μs		
			3.4 MHz mode	160	—	ns		VDD=3.3V, IPULLUP = 20mA, C <sub>LOAD</sub> =550pF
I2CM_17	TSU:STO	Stop Condition Setup Time	100 kHz mode	4.0	—	μs	VDD=3.3V, IPULLUP = 3mA, C <sub>LOAD</sub> =400pF	
			400 kHz mode	0.6	—	μs		
			1 MHz mode	0.26	—	μs		VDD=3.3V, IPULLUP = 20mA, C <sub>LOAD</sub> =550pF
			3.4 MHz mode	160	—	ns		VDD=3.3V, IPULLUP = 20mA, C <sub>LOAD</sub> =100pF
I2CM_21	TAA:SCL	Output Valid from Clock	100 kHz mode	—	3.45	μs	VDD=3.3V, IPULLUP = 3mA, C <sub>LOAD</sub> =400pF	
			400 kHz mode	—	0.9	μs		
			1 MHz mode	—	0.45	μs		VDD=3.3V, IPULLUP = 20mA, C <sub>LOAD</sub> =550pF
			3.4 MHz mode	—	100	ns		VDD=3.3V, IPULLUP = 20mA, C <sub>LOAD</sub> =100pF
I2CM_23	TBF:SDA	Bus Free Time <sup>(2)</sup>	100 kHz mode	4.7	—	μs	VDD=3.3V, IPULLUP = 3mA, C <sub>LOAD</sub> =200pF	
			400 kHz mode	1.3	—	μs		
			1 MHz mode	0.5	—	μs		VDD=3.3V, IPULLUP = 20mA, C <sub>LOAD</sub> =550pF
			3.4 MHz mode	160	—	ns		VDD=3.3V, IPULLUP = 20mA, C <sub>LOAD</sub> =100pF

**Notes:**

1. Longest delay between data hold timing based on bitfield SDAHOLD of register CTRLA from SERCOM Module and timing based on 4 period of GCLK\_SERCOM for 100kHz/400kHz/1MHz mode.
2. The amount of time the bus must be free before a new transmission can start (STOP condition to START condition).

Figure 55-10. I<sup>2</sup>C Start/Stop Bits Client Mode Timing Diagrams

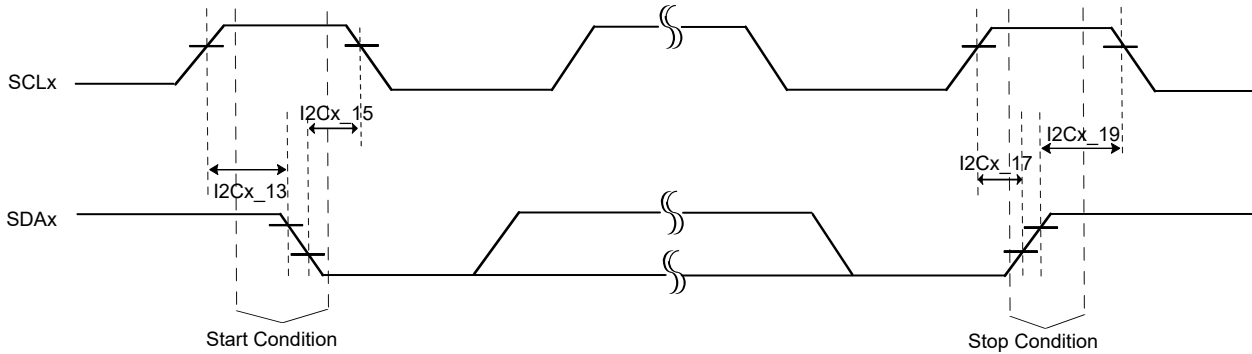


Figure 55-11. I<sup>2</sup>C Bus Data Client Mode Timing Diagrams

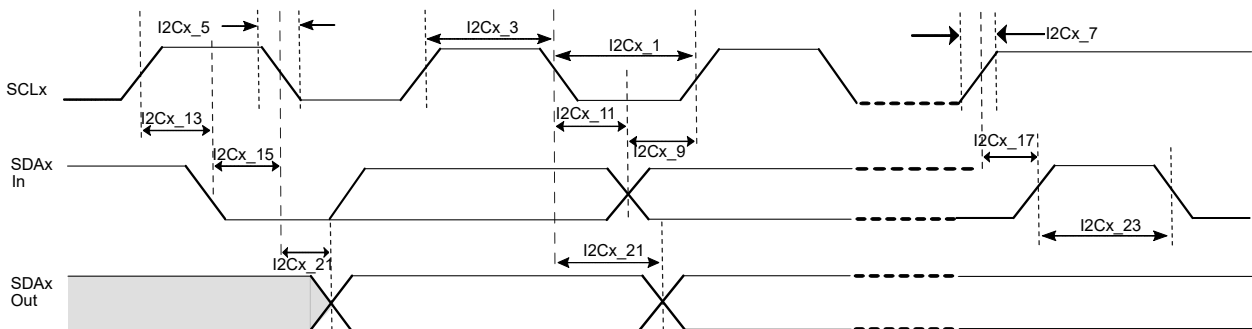


Table 55-39. I<sup>2</sup>C Client Mode Electrical Specifications

AC CHARACTERISTICS				Standard Operating Conditions: VDD = AVDD = 1.71V to 3.63V (unless otherwise stated) Operating temperature: -40°C ≤ T <sub>A</sub> ≤ +85°C for Industrial Temperature				
Param. No.	Symbol	Characteristics		Min.	Max.	Units	Conditions	
I2CS_1	TLO:SCL	Client Clock Low Time	100 kHz mode	4.7	—	μs	VDD=3.3V, IPULLUP = 3mA, C <sub>LOAD</sub> =400pF	
			400 kHz mode	1.3	—	μs		
			1 MHz mode	0.5	—	μs		VDD=3.3V, IPULLUP = 20mA, C <sub>LOAD</sub> =550pF
			3.4 MHz mode	160	—	ns		VDD=3.3V, IPULLUP =20mA, C <sub>LOAD</sub> =100pF
I2CS_3	THI:SCL	Client Clock High Time	100 kHz mode	4.0	—	μs	VDD=3.3V, IPULLUP = 3mA, C <sub>LOAD</sub> =400pF	
			400 kHz mode	0.6	—	μs		
			1 MHz mode	0.26	—	μs		VDD=3.3V, IPULLUP = 20mA, C <sub>LOAD</sub> =550pF
			3.4 MHz mode	60	—	ns		VDD=3.3V, IPULLUP =20mA, C <sub>LOAD</sub> =100pF

.....continued

AC CHARACTERISTICS				Standard Operating Conditions: VDD = AVDD = 1.71V to 3.63V (unless otherwise stated) Operating temperature: -40°C ≤ T <sub>A</sub> ≤ +85°C for Industrial Temperature			
Param. No.	Symbol	Characteristics	Min.	Max.	Units	Conditions	
I2CS_5	TF:SCL	SDAx and SCLx Fall Time	100 kHz mode	—	300	ns	VDD=3.3V, IPULLUP = 3mA, C <sub>LOAD</sub> =400pF
			400 kHz mode	—	300	ns	
			1 MHz mode	—	120	ns	
			3.4 MHz mode	—	40	ns	
I2CS_7	TR:SCL	SDAx and SCLx Rise Time	100 kHz mode	—	1000	ns	VDD=3.3V, IPULLUP = 3mA, C <sub>LOAD</sub> =400pF
			400 kHz mode	—	300	ns	
			1 MHz mode	—	120	ns	
			3.4 MHz mode	—	40	ns	
I2CS_9	TSU:DAT	Data Setup Time	100 kHz mode	250	—	ns	VDD=3.3V, IPULLUP = 3mA, C <sub>LOAD</sub> =400pF
			400 kHz mode	100	—	ns	
			1 MHz mode	50	—	ns	
			3.4 MHz mode	10	—	ns	
I2CS_11	THD:DAT	Data Hold Time <sup>(1)</sup>	100 kHz mode	300	—	ns	VDD=3.3V, IPULLUP = 3mA, C <sub>LOAD</sub> =400pF
			400 kHz mode	300	—	ns	
			1 MHz mode	300	—	ns	
			3.4 MHz mode	5	—	ns	
I2CS_13	TSU:STA	Start Condition Setup Time	100 kHz mode	4.7	—	μs	VDD=3.3V, IPULLUP = 3mA, C <sub>LOAD</sub> =400pF
			400 kHz mode	0.6	—	μs	
			1 MHz mode	0.26	—	μs	
			3.4 MHz mode	160	—	ns	



.....continued

AC CHARACTERISTICS				Standard Operating Conditions: VDD = AVDD = 1.71V to 3.63V (unless otherwise stated) Operating temperature: -40°C ≤ T <sub>A</sub> ≤ +85°C for Industrial Temperature				
Param. No.	Symbol	Characteristics	Min.	Max.	Units	Conditions		
I2CS_15	THD:STA	Start Condition Hold Time	100 kHz mode	4.0	—	μs	VDD=3.3V, IPULLUP = 3mA, C <sub>LOAD</sub> =400pF	
			400 kHz mode	0.6	—	μs		
			1 MHz mode	0.26	—	μs		
			3.4 MHz mode	160	—	ns		VDD=3.3V, IPULLUP =20mA, C <sub>LOAD</sub> =100pF
I2CS_17	TSU:ST0	Stop Condition Setup Time	100 kHz mode	4.0	—	μs	VDD=3.3V, IPULLUP = 3mA, C <sub>LOAD</sub> =400pF	
			400 kHz mode	0.6	—	μs		
			1 MHz mode	0.26	—	μs		VDD=3.3V, IPULLUP = 20mA, C <sub>LOAD</sub> =550pF
			3.4 MHz mode	160	—	ns		VDD=3.3V, IPULLUP =20mA, C <sub>LOAD</sub> =100pF
I2CS_21	TAA:SCL	Output Valid from Clock	100 kHz mode	—	3.45	μs	VDD=3.3V, IPULLUP = 3mA, C <sub>LOAD</sub> =400pF	
			400 kHz mode	—	0.9	μs		
			1 MHz mode	—	0.45	μs		VDD=3.3V, IPULLUP = 20mA, C <sub>LOAD</sub> =550pF
			3.4 MHz mode	—	100	ns		VDD=3.3V, IPULLUP =20mA, C <sub>LOAD</sub> =100pF
I2CS_23	TBF:SDA	Bus Free Time <sup>(2)</sup>	100 kHz mode	4.7	—	μs	VDD=3.3V, IPULLUP = 3mA, C <sub>LOAD</sub> =400pF	
			400 kHz mode	1.3	—	μs		
			1 MHz mode	0.5	—	μs		VDD=3.3V, IPULLUP = 20mA, C <sub>LOAD</sub> =550pF
			3.4 MHz mode	160	—	ns		VDD=3.3V, IPULLUP =20mA, C <sub>LOAD</sub> =100pF

**Notes:**

1. Longest delay between data hold timing based on bitfield SDAHOLD of register CTRLA from SERCOM Module and timing based on 4 period of GCLK\_SERCOM for 100kHz/400kHz/1MHz mode.
2. The amount of time the bus must be free before a new transmission can start (STOP condition to START condition).

## 55.29 QSPI Electrical Specifications

Figure 55-12. QSPI SDR Host Mode 0,1,2,3 Module Timing Diagram

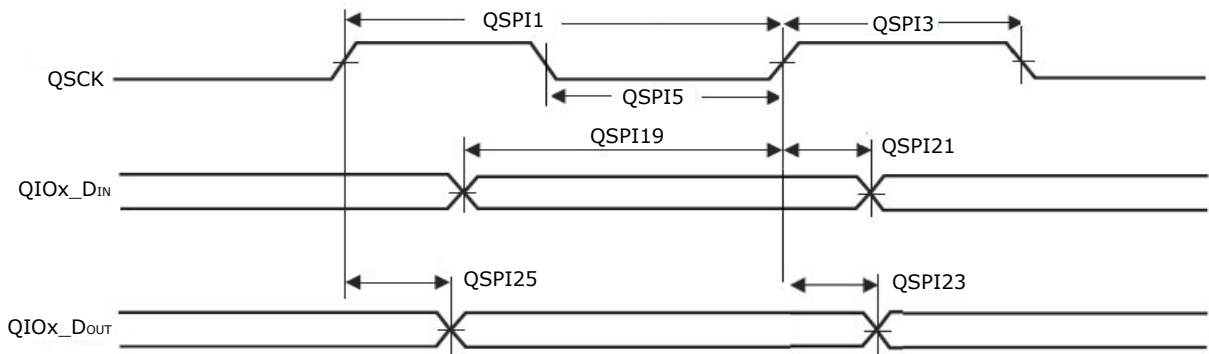


Figure 55-13. QSPI DDR Mode 0 Write Timing Diagram

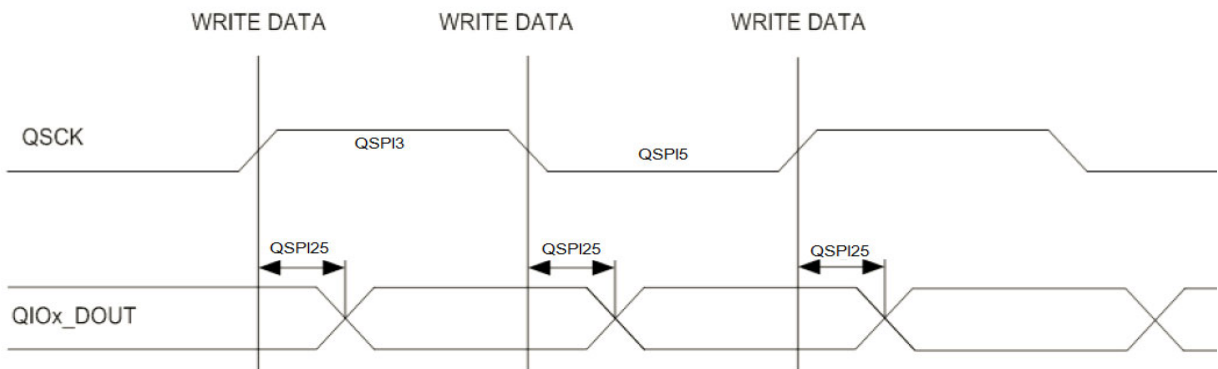
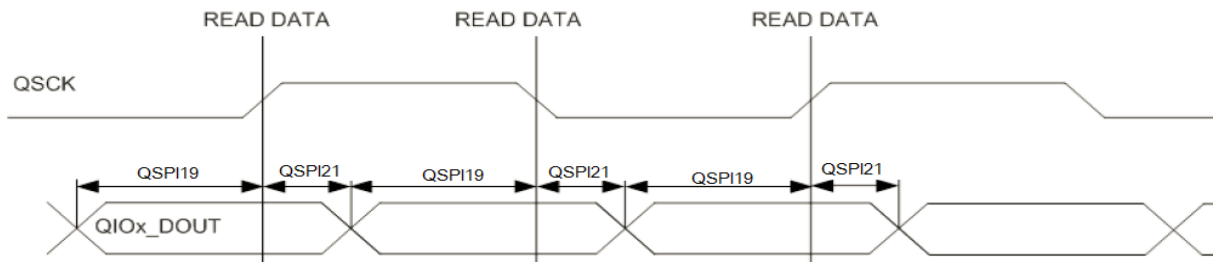


Figure 55-14. QSPI DDR Mode 0 Read Timing Diagram



**Table 55-40. QSPI Module Electrical Specifications (1)**

AC CHARACTERISTICS			Standard Operating Conditions: VDD = AVDD = 1.71V to 3.63V (unless otherwise stated) Operating temperature: -40°C ≤ T <sub>A</sub> ≤ +85°C for Industrial Temperature					
Param. No.	Symbol	Characteristics	Min.	Typ.	Max.	Units	Conditions	
QSPI_1	FCLK	Serial Clock Frequency	—	—	75	MHz	Host SDR Transfer Mode 0 and 2 (BAUD.CPHA = 0), VDD=3.3V, C <sub>LOAD</sub> =20pF(MAX)	
					50		Host SDR Transfer Mode 0 and 2 (BAUD.CPHA = 0), VDD=1.8V, C <sub>LOAD</sub> =20pF(MAX)	
					50		Host SDR Transfer Mode 1 and 3 (BAUD.CPHA = 1), VDD=3.3V, C <sub>LOAD</sub> =20pF(MAX)	
					50		Host SDR Transfer Mode 1 and 3 (BAUD.CPHA = 1), VDD=1.8V, C <sub>LOAD</sub> =20pF(MAX)	
					66		Host DDR Transfer Mode 0 in Read only (BAUD.CPHA = 0, BAUD.CPOL = 0), VDD=3.3V, C <sub>LOAD</sub> =20pF(MAX)	
					37.5		Host DDR Transfer Mode 0 in Read only (BAUD.CPHA = 0, BAUD.CPOL = 0), VDD=1.8V, C <sub>LOAD</sub> =20pF(MAX)	
QSPI_3	TSCKH	Serial Clock High Time	1/(2*FCLK)	—	—	ns	—	
QSPI_5	TSCKL	Serial Clock Low Time	1/(2*FCLK)	—	—	ns	—	
QSPI_7	TSCKR	Serial Clock Rise Time	—	—	DI_27	ns	DI_27: Refer to <a href="#">I/O Pin Electrical Specifications</a>	
QSPI_9	TSCKF	Serial Clock Fall Time	—	—	DI_25	ns	DI_25: Refer to <a href="#">I/O Pin Electrical Specifications</a>	
QSPI_19	TDIS	Data In Setup Time	4.3	—	—	ns	VDD= 3.3V Host SDR mode 0	
							4.55	VDD= 3.3V Host SDR mode 1
							4.17	VDD= 3.3V Host SDR mode 2
							4.68	VDD= 3.3V Host SDR mode 3
							4.17	VDD= 3.3V Host DDR mode 0
QSPI_21	TDIH	Data In Hold Time	0	—	—	ns	VDD= 3.3V Host SDR mode 0	
							0	VDD= 3.3V Host SDR mode 1
							0	VDD= 3.3V Host SDR mode 2
							0	VDD= 3.3V Host SDR mode 3
							0	VDD= 3.3V Host DDR mode 0
QSPI_23	TDOH	Data Out Hold	0	—	—	ns	—	

.....continued

AC CHARACTERISTICS			Standard Operating Conditions: VDD = AVDD = 1.71V to 3.63V (unless otherwise stated) Operating temperature: -40°C ≤ T <sub>A</sub> ≤ +85°C for Industrial Temperature				
Param. No.	Symbol	Characteristics	Min.	Typ.	Max.	Units	Conditions
QSPI_25	TDOV	Data Out Valid	—	—	2.37	ns	VDD=3.3V Host SDR mode 0
			—	—	2.96	ns	VDD= 3.3V Host SDR mode 1
			—	—	2.37	ns	VDD= 3.3V Host SDR mode 2
			—	—	2.73	ns	VDD= 3.3V Host SDR mode 3
			—	—	2.17	ns	VDD= 3.3V Host DDR mode 0

**Note:**  
1. Assumes VDD(MAX) and 20pF external load on all QSPI pins unless otherwise noted.

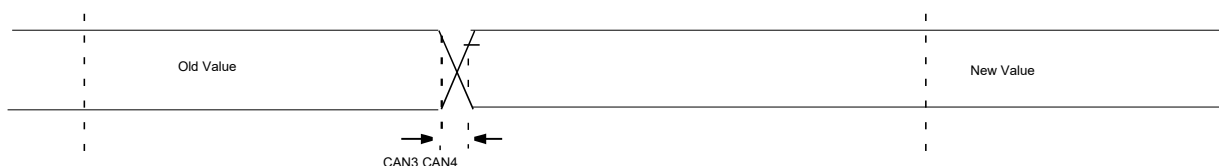
**Table 55-41.** QSPI Maximum Frequency Example <sup>(1)</sup>

AC CHARACTERISTICS			Standard Operating Conditions: VDD = AVDD = 1.71V to 3.63V (unless otherwise stated) Operating temperature: -40°C ≤ T <sub>A</sub> ≤ +85°C for Industrial Temperature			
QSPI Mode	CLK_QSPI2X_AHB	CLK_QSPI_AHB	Max. f <sub>CPU</sub>	Max. QSPI Serial Clock Frequency <sup>(2)</sup>	Conditions	
SDR	X	120 MHz	120 MHz	60 MHz	BAUD.BAUD[7:0] must be greater than 0 to ensure QSPI clock frequency is as per electrical specifications provided	
	X	75 MHz	75 MHz	75 MHz	-	
DDR	132 MHz	66 MHz	66 MHz	66 MHz	MCLK: HSDIV.DIV=0x01 MCLK: CPUDIV.DIV=0x02	

**Notes:**  
1. Examples shown do not supersede the electrical specification shown in QSPI Module Electrical Specifications table.  
2. Refer to QSPI\_1 for maximum QSPI Serial Clock Frequency (FCLK) in SDR and DDR modes.

## 55.30 CAN Electrical Specifications

**Figure 55-15.** CAN Module Timing Diagram



**Table 55-42. CAN Module Electrical Specifications**

AC CHARACTERISTICS			Standard Operating Conditions: VDD = AVDD = 1.71V to 3.63V (unless otherwise stated) Operating temperature : -40°C ≤ T <sub>A</sub> ≤ +85°C for Industrial Temperature				
Param. No.	Symbol	Characteristics	Min.	Typ.	Max.	Units	Conditions
CAN_1	CANRATE	CAN data rate	—	—	8	Mbps	VDD = 1.8V or VDD(min.) whichever is greater, C <sub>LOAD</sub> = 20 pF(max.)
			—	—	8	Mbps	VDD = 3.3V, C <sub>LOAD</sub> = 20 pF(max.)
CAN_3	CANFALL <sup>(1)</sup>	Port Output Fall Time	—	—	DI_27	ns	DI_27: Refer to <a href="#">I/O Pin Electrical Specifications</a>
CAN_4	CANRISE <sup>(1)</sup>	Port Output Rise Time	—	—	DI_25	ns	DI_25: Refer to <a href="#">I/O Pin Electrical Specifications</a>
CAN_7	fCAN_GCLK	CANx Input clock freq, GCLK_CAN	—	—	FCLK_25	MHz	FCLK_25: Refer to <a href="#">Maximum Clock Frequencies Electrical Specifications</a>

**Note:**

- Assumes VDD(min.) and 20 pF external load on all CAN pins unless otherwise noted.

## 55.31 TC Electrical Specifications

Figure 55-16. TC Timer Capture Input Module Timing Diagrams

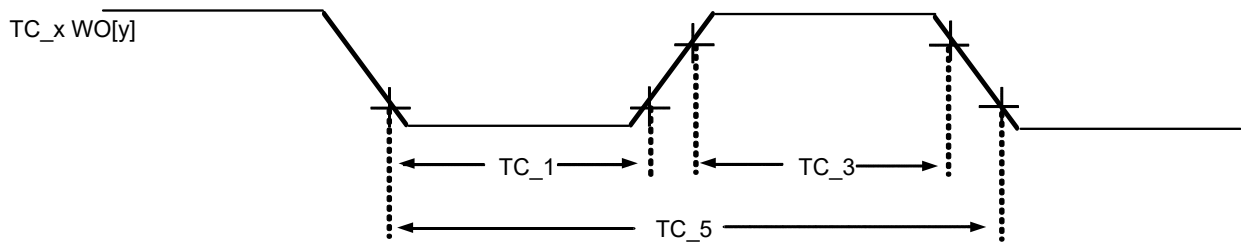


Figure 55-17. TC Timer Compare Output Module Timing Diagrams

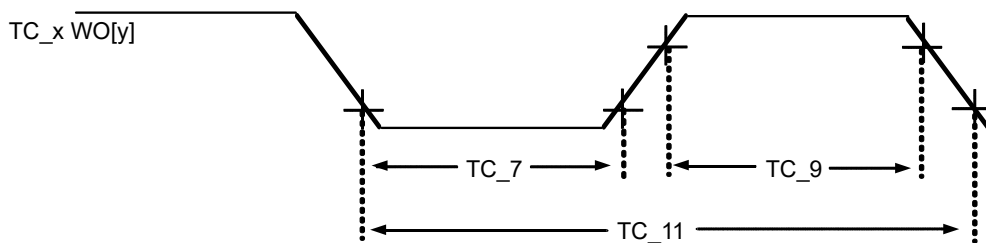


Table 55-43. TC Timer Capture Module Electrical Specifications

AC CHARACTERISTICS			Standard Operating Conditions: VDD = AVDD = 1.71V to 3.63V (unless otherwise stated) Operating temperature: -40°C ≤ T <sub>A</sub> ≤ +85°C for Industrial Temperature				
Param. No.	Symbol	Characteristics	Min.	Typ.	Max.	Units	Conditions
TC_1	TC <sub>INLOW</sub>	Capture TCx Input Low Time	2/fGCLK_TCx	—	—	ns	VDD(min.)
TC_3	TC <sub>INHIGH</sub>	Capture TCx Input High Time	2/fGCLK_TCx	—	—	ns	VDD(min.)
TC_5	TC <sub>INPERIOD</sub>	Capture Input Period	4/fGCLK_TCx	—	—	ns	VDD(min.)
TC_7	TC <sub>OUTLOW</sub>	Compare TCx Output Low Time	3*DI_28	—	—	ns	VDD(min) DI_28: Refer to <a href="#">I/O Pin Electrical Specifications</a>
TC_9	TC <sub>OUTHIGH</sub>	Compare TCx Output High Time	3*DI_26	—	—	ns	VDD(min) DI_26: Refer to <a href="#">I/O Pin Electrical Specifications</a>
TC_11	TC <sub>OUTPERIOD</sub>	Compare Output Period	TC_7+TC_9	—	—	ns	VDD(min)
TC_13	f <sub>GCLK_TCx</sub>	TC peripheral module clock frequency	—	—	FCLK_37	MHz	VDD(min.), for TC0,1,2,3 FCLK_37: Refer to <a href="#">Maximum Clock Frequencies Electrical Specifications</a>
			—	—	FCLK_39	MHz	VDD(min.), for TC4,5,6,7 FCLK_39: Refer to <a href="#">Maximum Clock Frequencies Electrical Specifications</a>



## 55.32 TCC Electrical Specifications

Figure 55-18. TCC Timer Capture Input Module Timing Diagrams

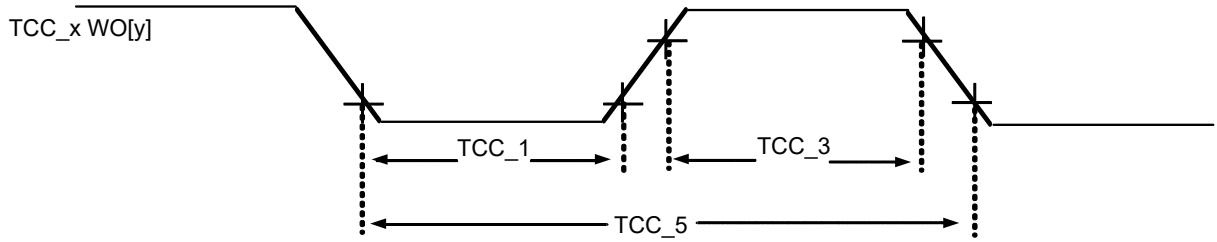


Figure 55-19. TCC Timer Compare Output Module Timing Diagrams

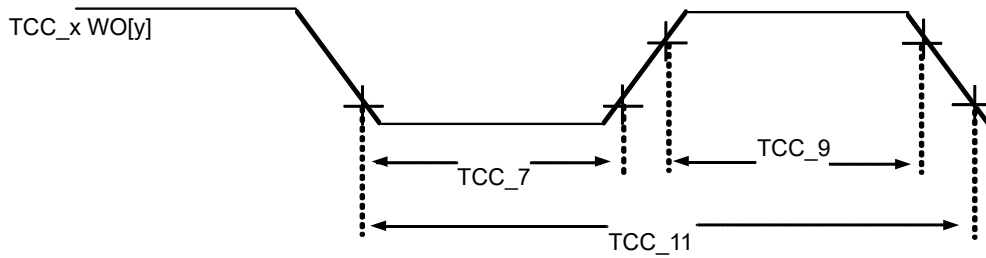
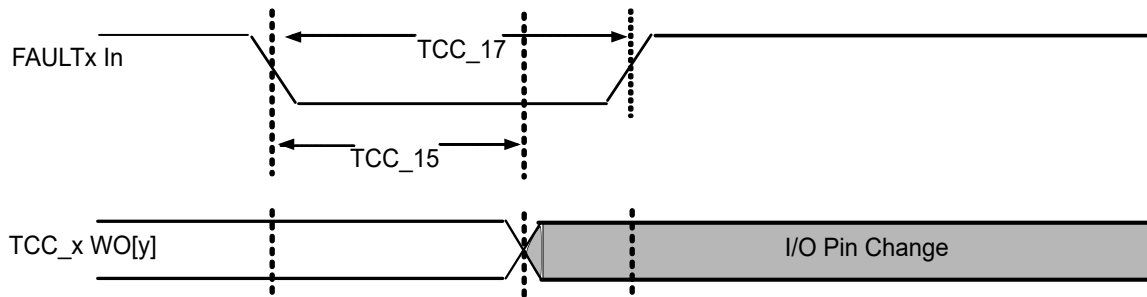


Figure 55-20. TCC Timer Compare Fault Output Module Timing Diagrams





**Table 55-44. TCC Timer Capture Module Electrical Specifications**

AC CHARACTERISTICS			Standard Operating Conditions: VDD = AVDD = 1.71V to 3.63V (unless otherwise stated) Operating temperature: -40°C ≤ T <sub>A</sub> ≤ +85°C for Industrial Temperature				
Param. No.	Symbol	Characteristics	Min.	Typ.	Max.	Units	Conditions
TCC_1	TCC <sub>INLOW</sub>	Capture TCCx Input Low Time	2/fGCLK_TCCx	—	—	ns	VDD(min)
TCC_3	TCC <sub>INHIGH</sub>	Capture TCCx Input High Time	2/fGCLK_TCCx	—	—	ns	VDD(min)
TCC_5	TCC <sub>INPERIOD</sub>	Capture Input Period	4/fGCLK_TCCx	—	—	ns	VDD(min)
TCC_7	TCC <sub>OUTLOW</sub>	Compare TCCx Output Low Time	3*DI_28	—	—	ns	VDD(min) DI_28: Refer to <a href="#">I/O Pin Electrical Specifications</a>
TCC_9	TCC <sub>OUTHIGH</sub>	Compare TCCx Output High Time	3*DI_26	—	—	ns	VDD(min) DI_26: Refer to <a href="#">I/O Pin Electrical Specifications</a>
TCC_11	TCC <sub>OUTPERIOD</sub>	Compare Output Period	TCC_7+TCC_9	—	—	ns	VDD(min)
TCC_13	f <sub>GCLK_TCCx</sub>	TCC peripheral module clock frequency	—	—	FCLK_35	MHz	VDD(min) FCLK_35: Refer to <a href="#">Maximum Clock Frequencies Electrical Specifications</a>
TCC_15	TCC <sub>FD</sub>	Fault Input to I/O Pin Change	—	—	42	ns	VDD(min)
TCC_17	TCC <sub>FLT</sub>	Fault Input Pulse Width	18	—	—	ns	VDD(min)

## 55.33 USB Electrical Specifications

**Table 55-45.** USB Electrical Specifications

AC CHARACTERISTICS			Standard Operating Conditions: VDD = AVDD = 1.71V to 3.63V (unless otherwise stated) Operating temperature: -40°C ≤ T <sub>A</sub> ≤ +85°C for Industrial Temperature				
Param. No.	Symbol	Characteristics <sup>(1)</sup>	Min.	Typ.	Max.	Units	Conditions
USB_1	VDDUSB	USB Transceiver Voltage	3	—	3.6	V	Voltage on VDD must be in this range for proper USB operation
<b>VBUS Supply</b>							
USB_7	VILUSB	Input Low Voltage for USB Buffer	—	—	0.8	V	—
USB_9	VIHUSB	Input High Voltage for USB Buffer	2	—	—	V	—
USB_11	VDIFS	Differential Input Sensitivity	0.2	—	—	V	The difference between D+ and D- must exceed this value while VCM is met
USB_13	VCM	Differential Common Mode Range	0.8	—	2.5	V	VDDUSB = 3.0V-to-3.6V
USB_15	ZOUT	Driver Output Impedance	28	—	44	Ω	—
USB_17	VOLUSB	Voltage Output Low	—	—	0.3	V	1.425 kΩ load connected to VUSB=3.6V
USB_19	VOHUSB	Voltage Output High	2.8	—	—	V	14.25 kΩ load connected to ground w/ VUSB=3.0V
USB_23	USBCLKS	USB Clock Source <sup>(1)</sup> GCLK_USB of 48 MHz ± 0.25%	—	48	—	MHz	GCLK_USB = 48 MHz ± 0.25%
USB_25	USBAHB	Min. AHB Clock for USB Operations	12	—	—	MHz	—
<b>Note:</b>							
1. External Crystal or clock oscillator ppm ≤ 50 w/FDPLL only for GCLK_USB_ of 48 MHz ± 0.25%.							

**Table 55-46.** USB Clock Configuration

USB Clock configuration			Standard Operating Conditions: VDD = AVDD = 1.71V to 3.63V (unless otherwise stated) Operating temperature: -40°C ≤ T <sub>A</sub> ≤ +85°C for Industrial Temperature	
Param. No.	Symbol	Characteristics	Device mode operation.	Host mode operation.
USB_30	USB_GCLK_SRC	DFLL48M Open loop	No	No
		DFLL48M Close loop, Ref. internal OSC source	No	No
		DFLL48M Close loop, Ref. external XOSC source	Yes	No
		DFLL48M Close loop, Ref. SOF (USB recovery mode)	Yes <sup>(1)</sup>	N/A
		FDPLL internal OSC (32K, 8M...)	No	No
		FDPLL external OSC (<1MHz)	Yes	No
		FDPLL external OSC (>1MHz)	Yes <sup>(2)</sup>	Yes
<b>Notes:</b>				
1. When using DFLL48M in USB recovery mode, the Fine Step value must be 0x0A to guarantee a USB clock at +/-0.25% before 11ms after a resume. Only usable in LDO regulator mode.				
2. FDPLL lock time is short when the clock frequency source is high (>1 MHz). Therefore, FDPLL and external OSC can be stopped during USB suspend mode to reduce consumption and guarantee a USB resume signal time (See USB specification).				

## 55.34 PCC Electrical Specifications

Figure 55-21. PCC Module Timing Diagram

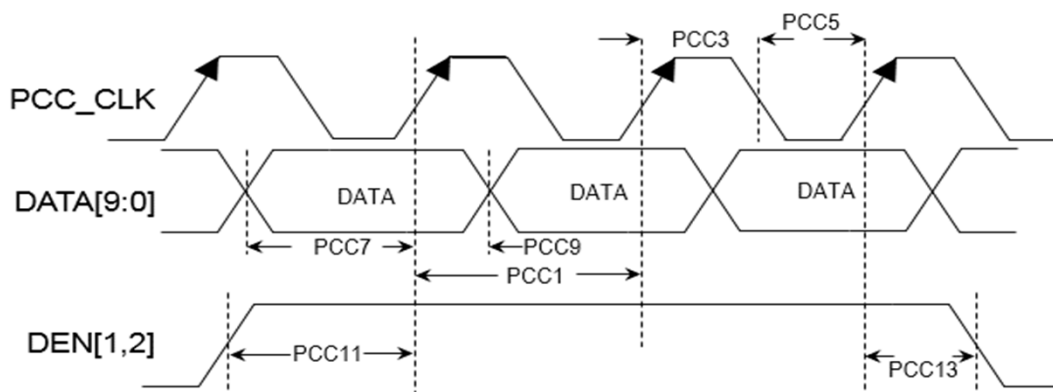


Table 55-47. PCC Electrical Specifications

AC CHARACTERISTICS			Standard Operating Conditions: VDD = AVDD = 1.71V to 3.63V (unless otherwise stated) Operating temperature: -40°C ≤ T <sub>A</sub> ≤ +85°C for Industrial Temperature				
Param. No.	Symbol	Characteristics	Min.	Typ.	Max.	Units	Conditions
PCC_1	PCC_CLK	External PCC Data Input Clock Period	20	—	—	ns	VDD(min) FCLK_5: Refer to <a href="#">Maximum Clock Frequencies Electrical Specifications</a>
PCC_3	PCCHIGH	PCC Data Clock input High time	10	—	—	ns	
PCC_5	PCCLOW	PCC Data Clock input Low time	10	—	—	ns	
PCC_7	PCCDSETUP	Clock to Data Setup Time	3	—	—	ns	
PCC_9	PCCDHOLD	Clock to Data Hold Time	2	—	—	ns	
PCC_11	PCCDENBSETUP <sup>(2)</sup>	Data Enable [1,2] Setup Time	3	—	—	ns	
PCC_13	PCCDENBHOLD <sup>(3)</sup>	Data Enable [1,2] Hold Time	2	—	—	—	
PCC_15	CLK_APB_PCC <sup>(1)</sup>	Internal MCLK PCC Module Clock	—	—	FCLK_5	MHz	

**Notes:**

- CLK\_APB\_PCC ≥ (2 \* PCC\_1).
- PCCDENBSETUP ≥ PCC\_7.
- PCCDENBHOLD ≥ PCC\_9.

## 55.35 NVM Block (Flash, Data Flash, NVM Configuration Rows) Electrical Specifications

Table 55-48. Flash NVM Electrical Specifications

AC CHARACTERISTICS			Standard Operating Conditions: VDD = AVDD = 1.71V to 3.63V (unless otherwise stated) Operating temperature: -40°C ≤ T <sub>A</sub> ≤ +85°C for Industrial Temperature					
Param. No.	Symbol	Characteristics	Min.	Typ.	Max.	Units	Conditions	
NVM_1	FRETEN	Flash Data Retention	20	—	—	Years	Under all conditions less than Absolute Maximum Ratings specifications	
NVM_3	EP	Cell Endurance (Flash Erase and Write Operation)	10	—	—	kCycles		
NVM_5	F <sub>READ</sub> <sup>(1)</sup>	Flash Read	0 Wait States	—	—	19	MHz	CTRLA.AUTOWS=0
			1 Wait States	—	—	38		
			2 Wait States	—	—	57		
			3 Wait States	—	—	76		
			4 Wait States	—	—	95		
			5 Wait States	—	—	100		
NVM_7	T <sub>FPW</sub>	Program Cycle Time	Write Page	—	1.5	3	ms	—
NVM_9	T <sub>CE</sub>		Erase Chip	—	15	25	s	—
NVM_11	T <sub>FEB</sub>		Erase Block	—	—	200	ms	—
NVM_13	IDD <sub>PROG</sub>	Supply Current during Programming	—	—	8	mA	VDD=3.3V	

**Note:**

- Maximum FLASH operating frequencies are given in the table above, but are limited by the Embedded Flash access time when the processor is fetching code out of it. These tables provide the device maximum operating frequency defined by the field RWS of the NVM\_CTRL CTRLA register when automatic wait states (AUTOWS) is disabled. This field defines the number of Wait states required to access the Embedded Flash Memory.

## 55.36 EEPROM Electrical Specifications

Table 55-49. EEPROM Electrical Specifications <sup>(1)</sup>

AC CHARACTERISTICS			Standard Operating Conditions: VDD = AVDD = 1.71V to 3.63V (unless otherwise stated) Operating temperature: -40°C ≤ T <sub>A</sub> ≤ +85°C for Industrial Temperature				
Param. No.	Symbol	Characteristics	Min.	Typ.	Max.	Units	Conditions
EEP_1	EERETEN <sup>(2)</sup>	EEPROM Data Retention	20	—	—	Yrs	—
EEP_3	EEP <sup>(2)</sup>	EEPROM Cell Endurance (EEPROM Erase or Write Operation)	32 x NVM_3	—	—	kCycles	All virtual space is occupied SEESTAT.SBLK=1, SEESTAT.PSZ=0 SEESTAT.SBLK=1, SEESTAT.PSZ=1 SEESTAT.SBLK=1, SEESTAT.PSZ=2 SEESTAT.SBLK=1, SEESTAT.PSZ=3 NVM_3: Refer to <a href="#">NVM Block (Flash, Data Flash, NVM Configuration Rows) Electrical Specifications</a>
			16 x NVM_3	—	—		All virtual space is occupied SEESTAT.SBLK=2, SEESTAT.PSZ=4 NVM_3: Refer to <a href="#">NVM Block (Flash, Data Flash, NVM Configuration Rows) Electrical Specifications</a>
			10.6 x NVM_3	—	—		All virtual space is occupied SEESTAT.SBLK=3, SEESTAT.PSZ=5 NVM_3: Refer to <a href="#">NVM Block (Flash, Data Flash, NVM Configuration Rows) Electrical Specifications</a>
			6.4 x NVM_3	—	—		All virtual space is occupied SEESTAT.SBLK=5, SEESTAT.PSZ=6 NVM_3: Refer to <a href="#">NVM Block (Flash, Data Flash, NVM Configuration Rows) Electrical Specifications</a>
			3.2 x NVM_3	—	—		All virtual space is occupied SEESTAT.SBLK=10, SEESTAT.PSZ=7 NVM_3: Refer to <a href="#">NVM Block (Flash, Data Flash, NVM Configuration Rows) Electrical Specifications</a>
EEP_5	EE <sub>READ</sub>	EEPROM Read	0 Wait States	—	—	NVM_5	MHz VDD=3.3V, NVMCTRL CTRLA.AUTOWS ≥ 0
			1 Wait States	—	—	NVM_5	
			2 Wait States	—	—	NVM_5	
			3 Wait States	—	—	NVM_5	
			4 Wait States	—	—	NVM_5	
			5 Wait States	—	—	NVM_5	
6 Wait States	—	—	NVM_5				

.....continued

AC CHARACTERISTICS				Standard Operating Conditions: VDD = AVDD = 1.71V to 3.63V (unless otherwise stated) Operating temperature: -40°C ≤ T <sub>A</sub> ≤ +85°C for Industrial Temperature				
Param. No.	Symbol	Characteristics		Min.	Typ.	Max.	Units	Conditions
EEP_7	EE <sub>TWR</sub>	EEPROM Cycle Time	Write	—	—	NVM_7	ms	Write a bit from 0-to-1 NVM_7: Refer to <a href="#">NVM Block (Flash, Data Flash, NVM Configuration Rows) Electrical Specifications</a>
EEP_9				—	—	NVM_9	ms	Write a bit from 1-to-0 (Requires Block Erase) NVM_9: Refer to <a href="#">NVM Block (Flash, Data Flash, NVM Configuration Rows) Electrical Specifications</a>
EEP_11	EE <sub>TERASE</sub>		Erase	—	—	NVM_11	s	VDD=3.3V NVM_11: Refer to <a href="#">NVM Block (Flash, Data Flash, NVM Configuration Rows) Electrical Specifications</a>

**Notes:**

- EEPROM parameters are dependent upon NVM parameters tied to SmartEEPROM emulation algorithm.
- Under all conditions less than Absolute Maximum Ratings specifications.

## 55.37 GMAC Electrical Specifications

Figure 55-22. MII Ethernet Module Output Timing Diagram (Media-Independent Interface)

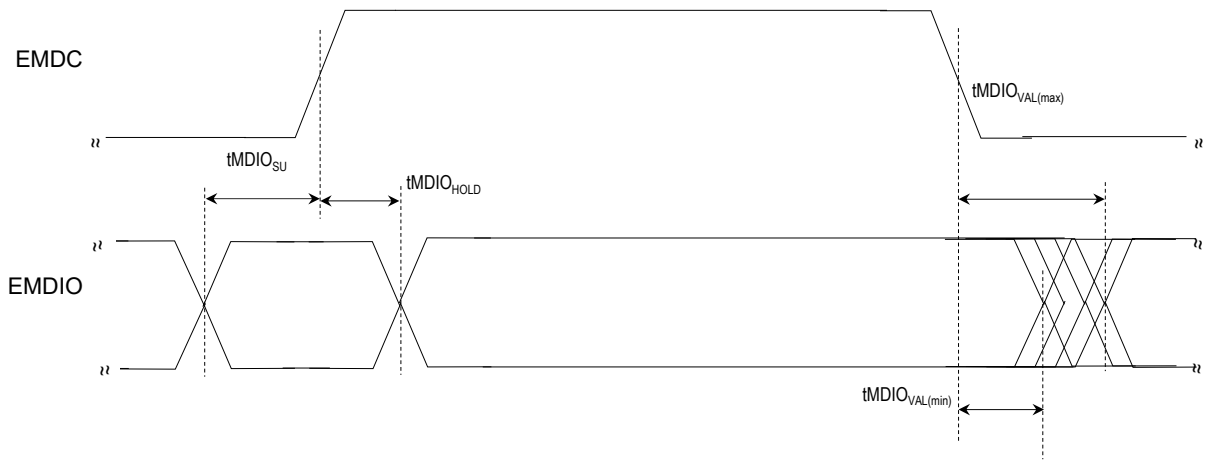


Figure 55-23. MII Receive Ethernet Module Timing Diagram (Media-Independent Interface)

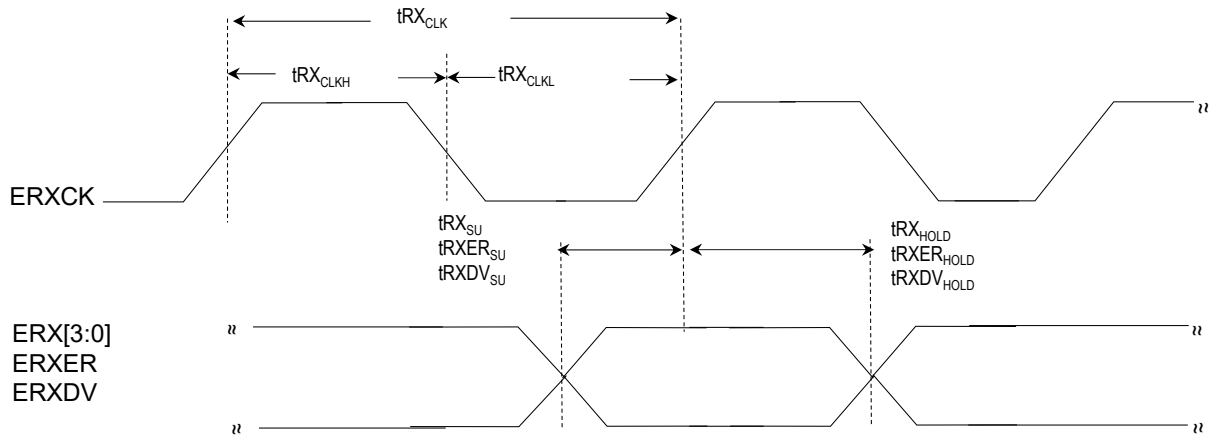


Figure 55-24. MII Transmit Ethernet Module Timing Diagram (Media-Independent Interface)

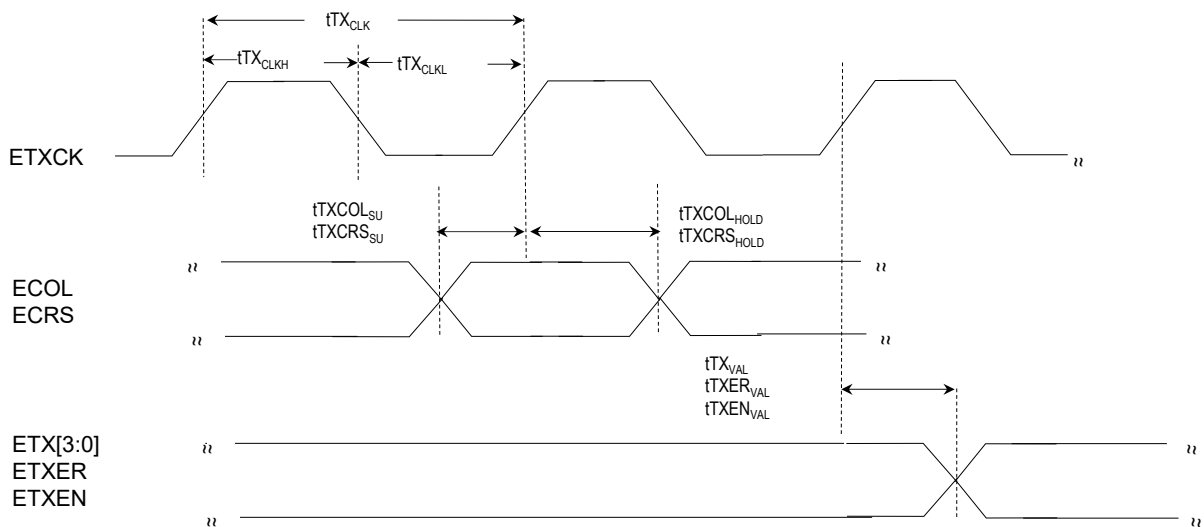


Table 55-50. MII RX/TX Ethernet Module Electrical Specifications

AC CHARACTERISTICS			Standard Operating Conditions: VDD = AVDD = 1.71V to 3.63V (unless otherwise stated) Operating temperature: -40°C ≤ T <sub>A</sub> ≤ +85°C for Industrial Temperature				
Param. No.	Symbol	Characteristics	Min.	Typ.	Max.	Units	Conditions
<b>MII Output AC TIMING Requirements</b>							
ET_1	tMDIO <sub>SU</sub>	MDIO Set-up Time	10	—	—	ns	VDD = 3.3V with C <sub>LOAD</sub> = 20 pF
ET_3	tMDIO <sub>HOLD</sub>	MDIO Hold Time	10	—	—	ns	
ET_5	tMDIO <sub>VAL</sub>	MDIO OUTPUT Valid Time	0	—	10	ns	
<b>MII RX AC TIMING Requirements</b>							
ET_7	tRX <sub>CLK</sub>	RXCLK Period	—	Note <sup>(1)</sup>	—	ns	VDD = 3.3V with C <sub>LOAD</sub> = 20 pF
ET_9	tRX <sub>CLKH</sub>	RXCLK High Time	tRXCLK / 2	—	—	ns	
ET_11	tRX <sub>CLKL</sub>	RXCLK Low Time	tRXCLK / 2	—	—	ns	
ET_13	tRX <sub>SU</sub> tRXER <sub>SU</sub> tRXDV <sub>SU</sub>	ERX[3:0], ERXER and ERXDV Set-up Time	10	—	—	ns	
ET_15	tRX <sub>HOLD</sub> tRXER <sub>HOLD</sub> tRXDV <sub>HOLD</sub>	ERX[3:0], ERXER and ERXDV Hold Time	10	—	—	ns	
<b>MII TX AC TIMING Requirements</b>							
ET_17	tTX <sub>CLK</sub>	TXCLK Period	—	Note <sup>(1)</sup>	—	ns	VDD = 3.3V with C <sub>LOAD</sub> = 20 pF
ET_19	tTX <sub>CLKH</sub>	TXCLK High Time	tTXCLK / 2	—	—	ns	
ET_21	tTX <sub>CLKL</sub>	TXCLK Low Time	tTXCLK / 2	—	—	ns	
ET_23	tTXCOL <sub>SU</sub> tTXCRS <sub>SU</sub>	TXCOL and TXCRS Set-up Time	10	—	—	ns	
ET_25	tTXCOL <sub>HOLD</sub> tTXCRS <sub>HOLD</sub>	TXCOL and TXCRS Hold Time	10	—	—	ns	
ET_27	tTX[3:0] <sub>VAL</sub> tTXER <sub>VAL</sub> tTXEN <sub>VAL</sub>	TX[3:0], TXER and TXEN valid times	10	—	25	ns	—
<b>Note:</b>							
1. 40 ns, (i.e., 25 MHz), for 100 BASE-TX operation, 400 ns, (i.e., 2.5 MHz), for 10 BASE-T operation. Clock source ppm ≤ 50.							



Figure 55-25. RMII Ethernet Module Timing Diagram (Reduced Media-Independent Interface)

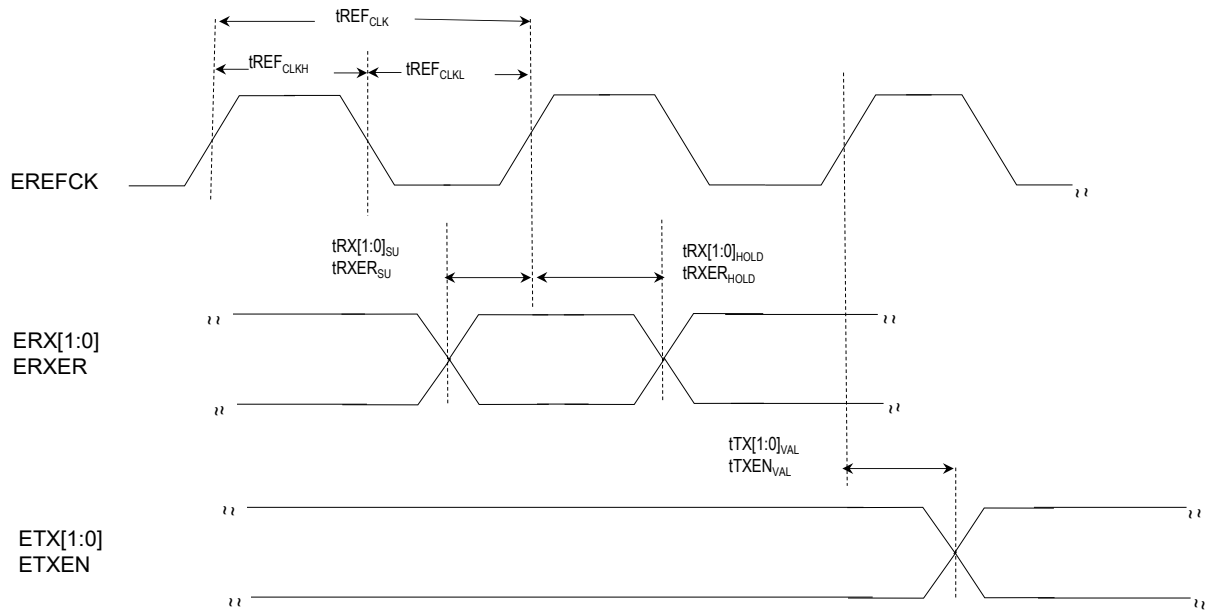


Table 55-51. RMII Ethernet Module Electrical Specifications (Reduced Media-Independent Interface)

AC CHARACTERISTICS			Standard Operating Conditions: VDD = AVDD = 1.71V to 3.63V (unless otherwise stated) Operating temperature: -40°C ≤ T <sub>A</sub> ≤ +85°C for Industrial Temperature				
Param. No.	Symbol	Characteristics	Min.	Typ.	Max.	Units	Conditions
ET_29	tREF_CLK	Reference Clock Frequency	—	20	—	ns	VDD = 3.3V with C <sub>LOAD</sub> = 20 pF
ET_31	tREF_CLKIH	Reference Clock High Time	—	tREFCLK / 2	—	ns	
ET_33	tREF_CLKIL	Reference Clock Low Time	—	tREFCLK / 2	—	ns	
ET_35	REF_CLKDC	Reference Clock Duty Cycle	—	50	—	%	
ET_41	tRX[1:0] <sub>SU</sub> tRXER <sub>SU</sub>	RXD[1:0], RXER Set-up time	4	—	—	ns	
ET_43	tRX[1:0] <sub>HOLD</sub> tRXER <sub>HOLD</sub>	RXD[1:0], RXER hold time	2	—	—	ns	
ET_45	tTX[1:0] <sub>VAL</sub> tTXEN <sub>VAL</sub>	TX[1:0], TXEN valid time	2	—	16	ns	

## 55.38 FREQM Electrical Specifications

**Table 55-52.** Frequency Meter Electrical Specifications

AC CHARACTERISTICS			Standard Operating Conditions: VDD = AVDD = 1.71V to 3.63V (unless otherwise stated) Operating temperature: -40°C ≤ T <sub>A</sub> ≤ +85°C for Industrial Temperature				
Param. No.	Symbol	Characteristics	Min.	Typ.	Max.	Units	Conditions
FM_1	FM <sub>LOW</sub>	GCLK_IOx Input Low Time	10	—	—	ns	VDD(min)
FM_3	FM <sub>HIGH</sub>	GCLK_IOx Input High Time	10	—	—	ns	
FM_5	FM <sub>PERIOD</sub>	GCLK_IOx Input Period	20	—	—	ns	VDD(min)
FM_7	f <sub>GCLK_FREQM_REF</sub>	FREQM Reference	—	—	FCLK_17	MHz	FCLK_15, FCLK_17: Refer to <a href="#">Maximum Clock Frequencies Electrical Specifications</a>
FM_9	f <sub>GCLK_FREQM_MSR</sub>	FREQM Measure	—	—	FCLK_15	MHz	

## 55.39 TRNG Electrical Specifications

**Table 55-53.** True Random Number Generator Module Electrical Specifications

AC CHARACTERISTICS			Standard Operating Conditions: VDD = AVDD = 1.71V to 3.63V (unless otherwise stated) Operating temperature: -40°C ≤ T <sub>A</sub> ≤ +85°C for Industrial Temperature				
Param. No.	Symbol	Characteristics	Min.	Typ.	Max.	Units	Conditions
TRNG_1	TRNG <sub>WKUP</sub>	Delay between TRNG Enable (CTRLA.ENABLE=1) and first random number read	100	—	—	ms	—

## 55.40 PDEC Electrical Specifications

Figure 55-26. Position Decoder (PDEC) Counter Mode Timing Diagram

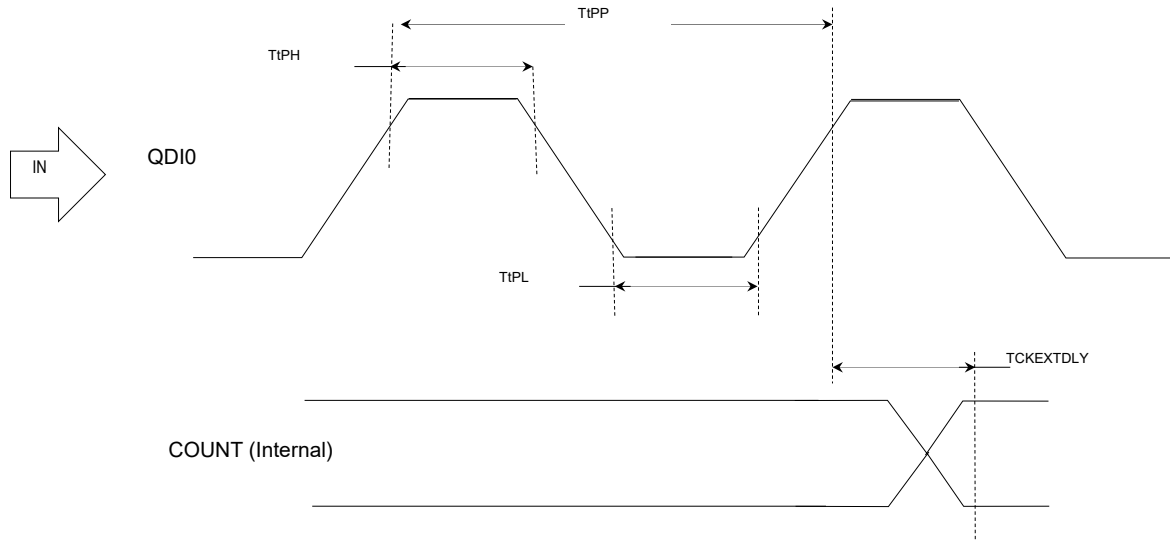
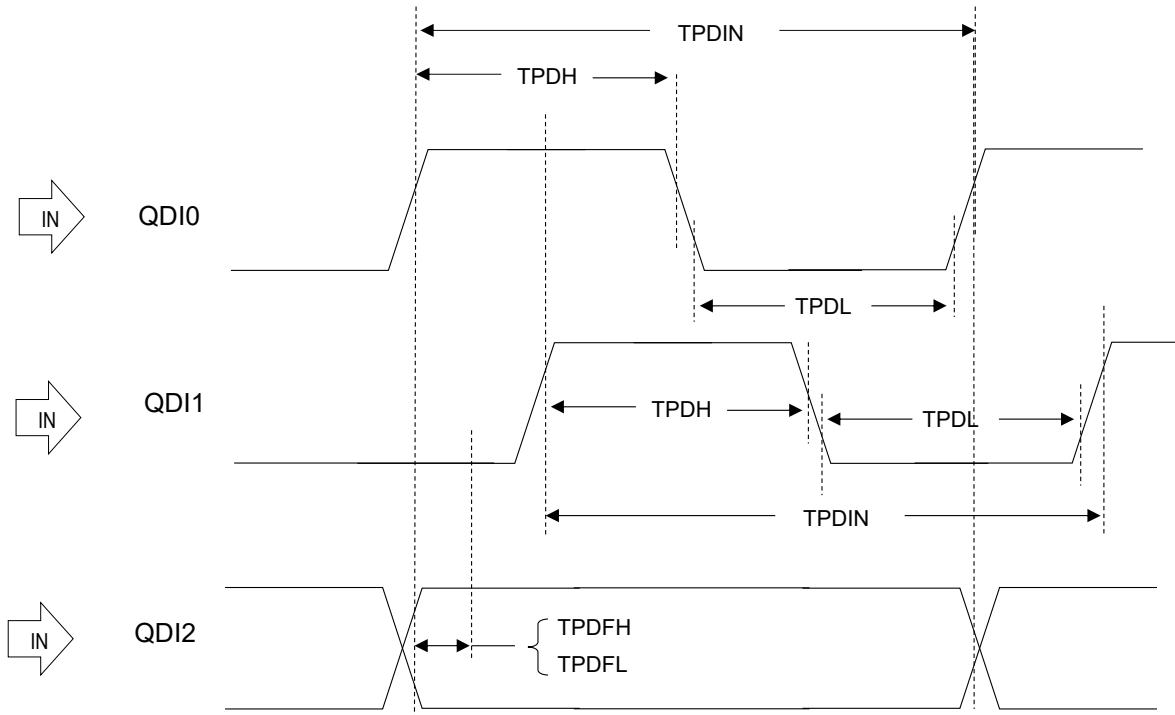


Figure 55-27. Position Decoder (PDEC) Input Timing Diagrams



**Table 55-54.** Quadrature Encoder Interface Electrical Specifications

AC CHARACTERISTICS			Standard Operating Conditions: VDD = AVDD = 1.71V to 3.63V (unless otherwise stated) Operating temperature: -40°C ≤ T <sub>A</sub> ≤ +85°C for Industrial Temperature				
Param. No.	Symbol	Characteristics	Min.	Typ.	Max.	Units	Conditions
PDEC_1	TtPH	TPCK high time	2/fGCLK_PDEC	—	—	ns	FCLK_41: Refer to <a href="#">Maximum Clock Frequencies Electrical Specifications</a>
PDEC_3	TtPL	TPCK low time	2/fGCLK_PDEC	—	—	ns	
PDEC_5	TtPP	TPCK input period	4/fGCLK_PDEC	—	—	ns	
PDEC_7	TCKEXTDLY	Delay from External TxCK Clock Edge to counter Increment	—	—	4/fGCLK_PDEC	ns	
PDEC_11	TPDH	Position Decoder Input High Time	4/fGCLK_PDEC	—	—	ns	
PDEC_13	TPDL	Position Decoder Input Low Time	4/fGCLK_PDEC	—	—	ns	
PDEC_15	TPDIN	Position Decoder Input Period	8/fGCLK_PDEC	—	—	ns	
PDEC_21	TPDFH	Filter Time to Recognize High, with Digital Filter	4/fGCLK_PDEC	—	—	ns	
PDEC_23	TPDFL	Filter Time to Recognize Low, with Digital Filter	4/fGCLK_PDEC	—	—	ns	
PDEC_24	fGCLK_PDEC	GCLK_PDEC	—	—	FCLK_41	MHz	

## 55.41 SDHC Electrical Specifications

Figure 55-28. SD/SDIO/MMC SDHC Module Timing Diagram

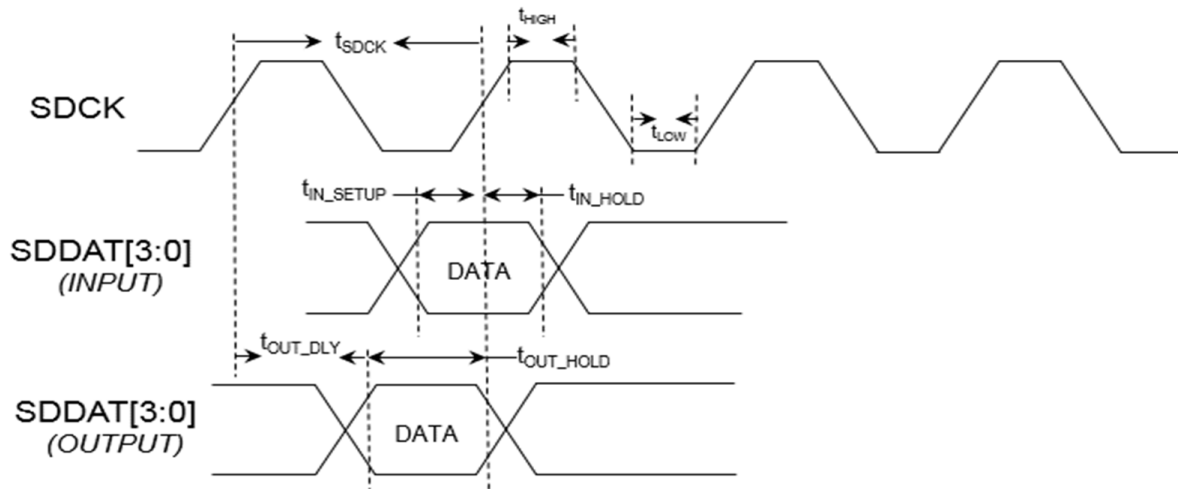


Table 55-55. SD Host Controller Timing Specifications <sup>(1)</sup>

AC CHARACTERISTICS			Standard Operating Conditions: VDD = AVDD = 1.71V to 3.63V (unless otherwise stated) Operating temperature: -40°C ≤ T <sub>A</sub> ≤ +85°C for Industrial Temperature				
Param. No.	Symbol	Characteristics	Min.	Typ.	Max.	Units	Conditions
SD_1	f <sub>GCLK_SDHCX_SLOW</sub>	Common SDHC slow input clock frequency	—	—	12	MHz	—
SD_3	f <sub>GCLK_SDHCX_CORE</sub>	SDHCx input clock frequency	—	—	150	MHz	—
<b>SD/SDIO Default Speed Mode</b>							
SD_5	t <sub>SDCK</sub>	Clock Frequency	—	—	25	MHz	—
SD_7	t <sub>DUTY</sub>	Duty Cycle	—	50	—	%	—
SD_9	t <sub>HIGH</sub>	Clock High Time	17.41	—	—	ns	—
SD_11	t <sub>LOW</sub>	Clock Low Time	17.46	—	—	ns	—
SD_13	t <sub>RISE</sub>	Clock Rise Time	DI_25			ns	DI_25: Refer to <a href="#">I/O Pin Electrical Specifications</a>
SD_15	t <sub>FALL</sub>	Clock Fall Time	DI_27			ns	DI_27: Refer to <a href="#">I/O Pin Electrical Specifications</a>
SD_17	t <sub>IN_SETUP</sub>	Input Setup Time	6	—	—	ns	—
SD_19	t <sub>IN_HOLD</sub>	Input Hold Time	1	—	—	ns	—
SD_21	t <sub>OUT_DLY</sub>	Output Delay Time	—	—	6	ns	VDD=3.3V, C <sub>LOAD</sub> OUT=20pF
SD_23	t <sub>OUT_SETUP</sub>	Output HOLD Time	3	—	—	ns	
<b>SD/SDIO High Speed Mode</b>							
SD_25	t <sub>SDCK</sub>	Clock Frequency	—	—	50	MHz	—
SD_27	t <sub>DUTY</sub>	Duty Cycle	—	50	—	%	—
SD_29	t <sub>HIGH</sub>	Clock High Time	7.87	—	—	ns	—
SD_31	t <sub>LOW</sub>	Clock Low Time	8.05	—	—	ns	—
SD_29	t <sub>RISE</sub>	Clock Rise Time	DI_25			ns	DI_25: Refer to <a href="#">I/O Pin Electrical Specifications</a>
SD_31	t <sub>FALL</sub>	Clock Fall Time	DI_27			ns	DI_27: Refer to <a href="#">I/O Pin Electrical Specifications</a>

.....continued

AC CHARACTERISTICS			Standard Operating Conditions: VDD = AVDD = 1.71V to 3.63V (unless otherwise stated) Operating temperature: -40°C ≤ T <sub>A</sub> ≤ +85°C for Industrial Temperature				
Param. No.	Symbol	Characteristics	Min.	Typ.	Max.	Units	Conditions
SD_33	t <sub>IN_SETUP</sub>	Input Setup Time	6	—	—	ns	—
SD_35	t <sub>IN_HOLD</sub>	Input Hold Time	1	—	—	ns	—
SD_37	t <sub>OUT_DLY</sub>	Output Delay Time	—	—	6	ns	VDD=3.3V, C <sub>LOAD</sub> OUT=20pF
SD_39	t <sub>OUT_SETUP</sub>	Output HOLD Time	3	—	—	ns	
<b>MMC Default Speed Mode</b>							
SD_41	t <sub>SDCK</sub>	Clock Frequency	—	—	26	MHz	—
SD_43	t <sub>DUTY</sub>	Duty Cycle	—	50	—	%	—
SD_45	t <sub>HIGH</sub>	Clock High Time	17.41	—	—	ns	—
SD_47	t <sub>LOW</sub>	Clock Low Time	17.46	—	—	ns	—
SD_49	t <sub>RISE</sub>	Clock Rise Time	DI_25			ns	DI_25: Refer to <a href="#">I/O Pin Electrical Specifications</a>
SD_51	t <sub>FALL</sub>	Clock Fall Time	DI_27			ns	DI_27: Refer to <a href="#">I/O Pin Electrical Specifications</a>
SD_53	t <sub>IN_SETUP</sub>	Input Setup Time	6	—	—	ns	—
SD_55	t <sub>IN_HOLD</sub>	Input Hold Time	8.3	—	—	ns	—
SD_57	t <sub>OUT_DLY</sub>	Output Delay Time	—	—	6	ns	VDD=3.3V, C <sub>LOAD</sub> OUT=20pF
SD_59	t <sub>OUT_SETUP</sub>	Output HOLD Time	3	—	—	ns	
<b>Note:</b>							
1. All output pins with 20pF load.							

## 55.42 SWD 2-Wire Electrical Specifications

Figure 55-29. SWD 2-Wire Read/Write Timing Diagrams

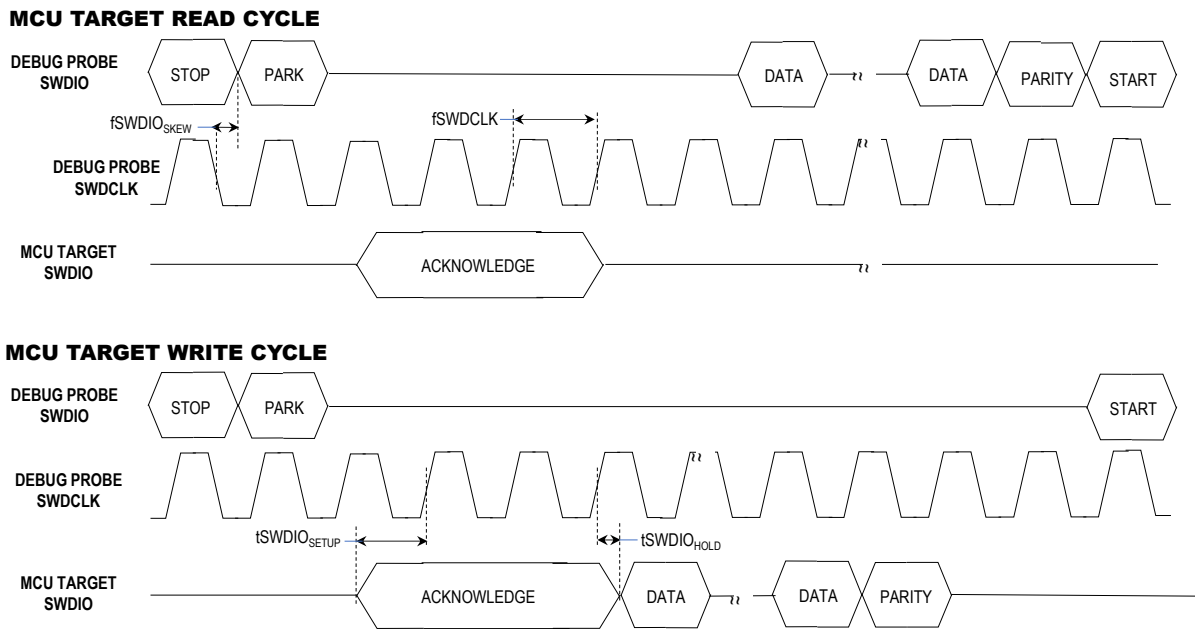


Table 55-56. SWD 2-Wire Electrical Specifications

AC CHARACTERISTICS			Standard Operating Conditions: VDD = AVDD = 1.71V to 3.63V (unless otherwise stated) Operating temperature: -40°C ≤ T <sub>A</sub> ≤ +85°C for Industrial Temperature				
Param. No.	Symbol	Characteristics	Min.	Typ.	Max.	Units	Conditions
SWD_1	fSWDCLK	SWDCLK Clock Frequency	—	—	20	MHz	T <sub>A</sub> = 85°C
SWD_3	tSWDCLKHIGH	SWDCLK Clock High Time	1 / (2 * fSWDCLK)	—	—	MHz	
SWD_5	tSWDCLKLOW	SWDCLK Clock Frequency	1 / (2 * fSWDCLK)	—	—	MHz	
SWD_7	tSWDIOSKEW	SWDIO SKEW	-5	—	5	ns	
SWD_9	tSWDIOSETUP	SWDIO Setup Time	4	—	—	ns	
SWD_11	tSWDIOHOLD	SWDIO Hold Time	1	—	—	ns	



## 56. Electrical Specifications 125°C

This section provides an overview of the electrical characteristics which are specific for devices running up to 125°C.

For all other values or missing characteristics, refer to [Electrical Specifications 85°C](#).

### 56.1 Disclaimer

Unless otherwise specified:

- Typical data are measured at  $T_A = 25^\circ\text{C}$ . They are for design guidance only and are not tested.
- All minimum and maximum values are valid across operating temperature and voltage.

### 56.2 General Operating Ratings and Thermal Conditions

**Table 56-1.** Operating Frequency versus Voltage (PIC32CX SG41)

Param. No.	VDD, AVDD Range	Temp. Range (in °C)	Max CPU Frequency	Comments
DC_5	1.71 to 3.63V	-40°C to +125°C	100 MHz	Extended
<b>Note:</b> The same voltage must be applied to VDD and AVDD.				

**Table 56-2.** Operating Frequency versus Voltage (PIC32CX SG60/SG61)

Param. No.	VDD, AVDD Range	Temp. Range (in °C)	Max CPU Frequency	Comments
DC_7	2.7 to 3.63V	-40°C to +125°C	100 MHz	Extended
<b>Note:</b> The same voltage must be applied to VDD and AVDD.				

**Table 56-3.** Thermal Operating Conditions

Rating	Symbol	Min.	Typ.	Max.	Unit
Extended Temperature Range:					
Operating Ambient Temperature Range	$T_A$	-40	—	125	°C
Operating Junction Temperature Range	$T_J$	---		145	

## 56.3 Power Supply

**Table 56-4.** Power Supply Electrical Specifications

DC CHARACTERISTICS			Standard Operating Conditions: VDD = AVDD = 1.71V to 3.63V (unless otherwise stated) Operating temperature: -40°C ≤ T <sub>A</sub> ≤ +125°C for Extended Temperature				
Param. No.	Symbol	Characteristics	Min.	Typ.	Max.	Units	Conditions
REG_45	VPOR	Power-on Reset	0.97	—	1.65	V	VDD Power up/Down (See Param REG_43, VDD Ramp Rate)
REG_47	VBOD33 <sup>(1,2)</sup>	VDD BOD (All modes)	1.45	—	1.57	V	SUPC.BOD33.LEVEL[7:0] = 0x00 (Min Value) , SUPC.BOD33.HYST[3:0] = 0x02
			1.60	—	1.72		SUPC.BOD33.LEVEL[7:0] = 0x19 (Recommended Value) , SUPC.BOD33.HYST[3:0] = 0x02
			1.62	—	1.74		SUPC.BOD33.LEVEL[7:0] = 0x1C (Recommended Value) , SUPC.BOD33.HYST[3:0] = 0x02
			2.93	—	3.32		SUPC.BOD33.LEVEL[7:0] = 0xFF (Max Value) , SUPC.BOD33.HYST[3:0] = 0x00

**Notes:**

- VBOD(min) = (1.5 + (SUPC.BOD33.LEVEL[7:0] \* VBOD33<sub>LEVEL\_STEP</sub>))  
VBOD(max) = (VBOD(min) + (SUPC.BOD33.HYST[3:0] \* VBOD33<sub>HYST\_STEP</sub>))
- If a hysteresis value is programmed, the following equation must be respected to avoid any overflow on VBOD(max) : LEVEL[7:0] value ≤ 255 - HYST[3:0] value.

## 56.4 MCU Active Current Consumption

**Table 56-5.** MCU Active Current Consumption Electrical Specifications<sup>(1,2,3)</sup>

DC CHARACTERISTICS				Standard Operating Conditions: VDD = AVDD = 1.71V to 3.63V (unless otherwise stated) Operating temperature: -40°C ≤ T <sub>A</sub> ≤ +125°C for Extended Temperature			
Param. No.	Symbol	Characteristics	Clock/Freq	Typ.	Max.	Units	Conditions
APWR_1	I <sub>DD_ACTIVE</sub>	LDO mode selected	FDPLL 100 MHz	—	232	μA/MHz	VDD = 3.3V XOSC32K = 32 kHz crystal with XOSC32K.CGM = 1
APWR_3				—	229	μA/MHz	VDD = 1.8V XOSC32K = 32 kHz crystal with XOSC32K.CGM = 1
APWR_5			DFLL 48 MHz	—	371	μA/MHz	VDD = 3.3V XOSC32K = 32 kHz crystal with XOSC32K.CGM = 1
APWR_7				—	370	μA/MHz	VDD = 1.8V XOSC32K = 32 kHz crystal with XOSC32K.CGM = 1
APWR_9			XOSC 32 MHz	—	613	μA/MHz	VDD = 3.3V XOSC32K.ENABLE = 0
APWR_11				—	611	μA/MHz	VDD = 1.8V XOSC32K.ENABLE = 0

.....continued

DC CHARACTERISTICS				Standard Operating Conditions: VDD = AVDD = 1.71V to 3.63V (unless otherwise stated) Operating temperature: -40°C ≤ T <sub>A</sub> ≤ +125°C for Extended Temperature			
Param. No.	Symbol	Characteristics	Clock/Freq	Typ.	Max.	Units	Conditions
APWR_13	I <sub>DD,ACTIVE</sub>	BUCK mode selected	FDPLL 100 MHz	—	176	μA/MHz	VDD = 3.3V XOSC32K = 32 kHz crystal with XOSC32K.CGM = 1
APWR_15				—	215	μA/MHz	VDD = 1.8V XOSC32K = 32 kHz crystal with XOSC32K.CGM = 1
APWR_17			DFLL 48 MHz	—	242	μA/MHz	VDD = 3.3V XOSC32K = 32 kHz crystal with XOSC32K.CGM = 1
APWR_19				—	324	μA/MHz	VDD = 1.8V XOSC32K = 32 kHz crystal with XOSC32K.CGM = 1
APWR_21			XOSC 32 MHz	—	370	μA/MHz	VDD = 3.3V XOSC32K.ENABLE = 0
APWR_23				—	505	μA/MHz	VDD = 1.8V XOSC32K.ENABLE = 0

**Notes:**

- Conditions:
  - No peripheral modules are operating (i.e. all peripherals inactive)
  - MCLK all APB clock masked except MCLK and NVMCTRL
  - MCLK.AHBMASK = 0x00C00FFF
  - CMCC Enable
  - CPU is running on Flash with automatic wait state
  - Low-power cache enabled
  - BOD33 is disabled
  - I/Os are inactive input mode with input trigger disabled
  - All clock generation sources disabled unless otherwise specified
  - WDT, RTC, CFD Clock Fail Detect disabled
  - RESET = VDD

**Note:** μA/MHz varies over temperature. Worst case is given by max.
- CPU Running CoreMark® Test Suite.
- For the PIC32CX SG60/SG61 variants, the current consumption of the HSM is not taken into account and must be added according to its operating mode. Refer to the "PIC32CX SG60/SG61 Hardware Security Module Addendum (DS60001750)" for additional information.

## 56.5 MCU Idle Current Consumption

**Table 56-6.** MCU Idle Current Consumption Electrical Specifications <sup>(1,2)</sup>

DC CHARACTERISTICS				Standard Operating Conditions: VDD = AVDD = 1.71V to 3.63V (unless otherwise stated) Operating temperature: -40°C ≤ T <sub>A</sub> ≤ +125°C for Extended Temperature			
Param. No.	Symbol	Characteristics	Clock/Freq	Typ.	Max.	Units	Conditions
IPWR_1	I <sub>DD_IDLE</sub>	LDO mode selected	FDPLL 100 MHz	—	116	μA/MHz	VDD = 3.3V XOSC32K = 32 kHz crystal with XOSC32K.CGM = 1
IPWR_3				—	114	μA/MHz	VDD = 1.8V XOSC32K = 32 kHz crystal with XOSC32K.CGM = 1
IPWR_5			DFLL 48 MHz	—	252	μA/MHz	VDD = 3.3V XOSC32K = 32 kHz crystal with XOSC32K.CGM = 1
IPWR_7				—	252	μA/MHz	VDD = 1.8V XOSC32K = 32 kHz crystal with XOSC32K.CGM = 1
IPWR_9			XOSC 32 MHz	—	371	μA/MHz	VDD = 3.3V XOSC32K.ENABLE = 0
IPWR_11				—	367	μA/MHz	VDD = 1.8V XOSC32K.ENABLE = 0
IPWR_13	I <sub>DD_IDLE</sub>	BUCK mode selected	FDPLL 100 MHz	—	78	μA/MHz	VDD = 3.3V XOSC32K = 32 kHz crystal with XOSC32K.CGM = 1
IPWR_15				—	89	μA/MHz	VDD = 1.8V XOSC32K = 32 kHz crystal with XOSC32K.CGM = 1
IPWR_17			DFLL 48 MHz	—	147	μA/MHz	VDD = 3.3V XOSC32K = 32 kHz crystal with XOSC32K.CGM = 1
IPWR_19				—	194	μA/MHz	VDD = 1.8V XOSC32K = 32 kHz crystal with XOSC32K.CGM = 1
IPWR_21			XOSC 32 MHz	—	223	μA/MHz	VDD = 3.3V XOSC32K.ENABLE = 0
IPWR_23				—	287	μA/MHz	VDD = 1.8V XOSC32K.ENABLE = 0

.....continued

DC CHARACTERISTICS				Standard Operating Conditions: VDD = AVDD = 1.71V to 3.63V (unless otherwise stated) Operating temperature: -40°C ≤ T <sub>A</sub> ≤ +125°C for Extended Temperature			
--------------------	--	--	--	---	--	--	--

Param. No.	Symbol	Characteristics	Clock/Freq	Typ.	Max.	Units	Conditions
------------	--------	-----------------	------------	------	------	-------	------------

**Notes:**

1. Conditions:

- No peripheral modules are operating (i.e. all peripherals inactive)
- MCLK all APB clock masked except MCLK and NVMCTRL
- MCLK.AHBMASK = 0x00C00FFF
- CMCC Enable
- CPU is running on Flash with automatic wait state
- Low-power cache enabled
- BOD33 is disabled
- I/Os are inactive input mode with input trigger disabled
- All clock generation sources disabled unless otherwise specified
- WDT, RTC, CFD Clock Fail Detect disabled
- $\overline{\text{RESET}} = \text{VDD}$

**Note:** μA/MHz varies over temperature. Worst case is given by max.

2. For the PIC32CX SG60/SG61 variants, the current consumption of the HSM is not taken into account and must be added according to its operating mode. Refer to the "PIC32CX SG60/SG61 Hardware Security Module Addendum (DS60001750)" for additional information.

## 56.6 MCU Standby Current Consumption

**Table 56-7.** MCU Standby Current Consumption Electrical Specifications <sup>(1,2)</sup>

DC CHARACTERISTICS			Standard Operating Conditions: VDD = AVDD = 1.71V to 3.63V (unless otherwise stated) Operating temperature: -40°C ≤ T <sub>A</sub> ≤ +125°C for Extended Temperature				
Param. No.	Symbol	Characteristics	VDD	Typ.	Max.	Units	Conditions
SPWR_1	I <sub>DD_STANDBY</sub>	LDO mode selected	3.3V	—	5.9	mA	Fast wake-up disabled (PM.STDBYCFG.FASTWKUP=0x0), No System RAM retained
SPWR_3			1.8V	—	5.9	mA	(PM.STDBYCFG.RAMCFG=0x2), 8 KB backup RAM retained (PM.BKUPCFG.BRAMCFG=0x0)
SPWR_5			3.3V	—	8.8	mA	Fast wake-up enabled (PM.STDBYCFG.FASTWKUP=0x3), No System RAM retained
SPWR_7			1.8V	—	8.7	mA	(PM.STDBYCFG.RAMCFG=0x2), 8 KB backup RAM retained (PM.BKUPCFG.BRAMCFG=0x0)
SPWR_9			3.3V	—	5.9	mA	Fast wake-up disabled (PM.STDBYCFG.FASTWKUP=0x0), RTC running on XOSC32K No System RAM retained (PM.STDBYCFG.RAMCFG=0x2).
SPWR_11			1.8V	—	5.9	mA	8 KB backup RAM retained (PM.BKUPCFG.BRAMCFG=0x0)
SPWR_13			3.3V	—	6.1	mA	Fast wake-up disabled (PM.STDBYCFG.FASTWKUP=0x0), RTC running on XOSC32K 32 KB System RAM retained (PM.STDBYCFG.RAMCFG=0x1),
SPWR_15			1.8V	—	6.1	mA	8 KB backup RAM retained (PM.BKUPCFG.BRAMCFG=0x0)
SPWR_17			3.3V	—	7.1	mA	Fast wake-up disabled (PM.STDBYCFG.FASTWKUP=0x0), RTC running on XOSC32K Full System RAM retained (PM.STDBYCFG.RAMCFG=0x0),
SPWR_19			1.8V	—	7.1	mA	8 KB backup RAM retained (PM.BKUPCFG.BRAMCFG=0x0)
SPWR_21			3.3V	—	5.6	mA	Fast wake-up enabled (PM.STDBYCFG.FASTWKUP=0x3), Full System RAM retained
SPWR_23			1.8V	—	1.7	mA	(PM.STDBYCFG.RAMCFG=0x0), No backup RAM retained (PM.BKUPCFG.BRAMCFG=0x2)
SPWR_25			3.3V	—	5.6	mA	fast wake-up enabled (PM.STDBYCFG.FASTWKUP=0x3), RTC running on XOSC32K Full System RAM retained (PM.STDBYCFG.RAMCFG=0x0),
SPWR_27			1.8V	—	1.8	mA	No backup RAM retained (PM.BKUPCFG.BRAMCFG=0x2)

.....continued

DC CHARACTERISTICS				Standard Operating Conditions: VDD = AVDD = 1.71V to 3.63V (unless otherwise stated) Operating temperature: -40°C ≤ T <sub>A</sub> ≤ +125°C for Extended Temperature			
Param. No.	Symbol	Characteristics	VDD	Typ.	Max.	Units	Conditions
SPWR_29	I <sub>DD_STANDBY</sub>	BUCK mode selected	3.3V	—	2.8	mA	Fast wake-up disabled (PM.STDBYCFG.FASTWKUP=0x0), No System RAM retained (PM.STDBYCFG.RAMCFG=0x2), 8 KB backup RAM retained (PM.BKUPCFG.BRAMCFG=0x0)
SPWR_31			1.8V	—	3.9	mA	
SPWR_33			3.3V	—	5.3	mA	Fast wake-up enabled (PM.STDBYCFG.FASTWKUP=0x3), No System RAM retained (PM.STDBYCFG.RAMCFG=0x2), 8 KB backup RAM retained (PM.BKUPCFG.BRAMCFG=0x0)
SPWR_35			1.8V	—	6.8	mA	
SPWR_37			3.3V	—	2.9	mA	Fast wake-up disabled (PM.STDBYCFG.FASTWKUP=0x0), RTC running on XOSC32K No System RAM retained (PM.STDBYCFG.RAMCFG=0x2), 8 KB backup RAM retained (PM.BKUPCFG.BRAMCFG=0x0)
SPWR_39			1.8V	—	4	mA	
SPWR_41			3.3V	—	3	mA	Fast wake-up disabled (PM.STDBYCFG.FASTWKUP=0x0), RTC running on XOSC32K 32 KB System RAM retained (PM.STDBYCFG.RAMCFG=0x1), 8 KB backup RAM retained (PM.BKUPCFG.BRAMCFG=0x0)
SPWR_43			1.8V	—	4.1	mA	
SPWR_45			3.3V	—	3.5	mA	Fast wake-up disabled (PM.STDBYCFG.FASTWKUP=0x0), RTC running on XOSC32K Full System RAM retained (PM.STDBYCFG.RAMCFG=0x0), 8 KB backup RAM retained (PM.BKUPCFG.BRAMCFG=0x0)
SPWR_47			1.8V	—	4.9	mA	
SPWR_49			3.3V	—	3.1	mA	Fast wake-up enabled (PM.STDBYCFG.FASTWKUP=0x3), Full System RAM retained (PM.STDBYCFG.RAMCFG=0x0), No backup RAM retained (PM.BKUPCFG.BRAMCFG=0x2)
SPWR_51			1.8V	—	1.3	mA	
SPWR_53			3.3V	—	3.1	mA	Fast wake-up enabled (PM.STDBYCFG.FASTWKUP=0x3), RTC running on XOSC32K Full System RAM retained (PM.STDBYCFG.RAMCFG=0x0), No backup RAM retained (PM.BKUPCFG.BRAMCFG=0x2)
SPWR_55			1.8V	—	1.3	mA	

.....continued

<b>DC CHARACTERISTICS</b>				Standard Operating Conditions: VDD = AVDD = 1.71V to 3.63V (unless otherwise stated) Operating temperature: -40°C ≤ T <sub>A</sub> ≤ +125°C for Extended Temperature			
---------------------------	--	--	--	--	--	--	--

Param. No.	Symbol	Characteristics	VDD	Typ.	Max.	Units	Conditions
------------	--------	-----------------	-----	------	------	-------	------------

**Notes:**

1. Conditions
  - No peripheral modules are operating (i.e. all peripherals inactive)
  - MCLK all APB clock masked except MCLK and NVMCTRL
  - MCLK.AHBMASK = 0x00C00FFF
  - BOD33 is disabled
  - I/Os are inactive input mode with input trigger disabled
  - All clock generation sources disabled unless otherwise specified
  - WDT, CFD Clock Fail Detect disabled
  - $\overline{\text{RESET}} = \text{VDD}$
2. For the PIC32CX SG60/SG61 variants, the current consumption of the HSM is not taken into account and must be added according to its operating mode. Refer to the "PIC32CX SG60/SG61 Hardware Security Module Addendum (DS60001750)" for additional information.



## 56.7 MCU Hibernate Current Consumption

**Table 56-8.** MCU Hibernate Current Consumption Electrical Specifications <sup>(1,2)</sup>

DC CHARACTERISTICS				Standard Operating Conditions: VDD = AVDD = 1.71V to 3.63V (unless otherwise stated) Operating temperature: -40°C ≤ T <sub>A</sub> ≤ +125°C for Extended Temperature			
Param. No.	Symbol	Characteristics	VDD	Typ.	Max.	Units	Conditions
HPWR_1	I <sub>DD_HIBERNATE</sub>	LDO mode selected	3.3V	—	320	μA	No peripheral running. No System RAM retained (PM.HIBCFG.RAMCFG=0x2)
HPWR_3			1.8V	—	316	μA	No backup RAM retained (PM.HIBCFG.BRAMCFG=0x2)
HPWR_5			3.3V	—	322	μA	RTC is running on XOSC32K No System RAM retained (PM.HIBCFG.RAMCFG=0x2)
HPWR_7			1.8V	—	318	μA	No backup RAM retained (PM.HIBCFG.BRAMCFG=0x2)
HPWR_9			3.3V	—	364	μA	RTC is running on XOSC32K No System RAM retained (PM.HIBCFG.RAMCFG=0x2)
HPWR_11			1.8V	—	359	μA	4 KB backup RAM retained (PM.HIBCFG.BRAMCFG=0x1)
HPWR_13			3.3V	—	405	μA	RTC is running on XOSC32K No System RAM retained (PM.HIBCFG.RAMCFG=0x2)
HPWR_15			1.8V	—	400	μA	8 KB backup RAM retained (PM.HIBCFG.BRAMCFG=0x0)
HPWR_17			3.3V	—	641	μA	RTC is running on XOSC32K 32 KB System RAM retained (PM.HIBCFG.RAMCFG=0x1)
HPWR_19			1.8V	—	636	μA	8 KB backup RAM retained (PM.HIBCFG.BRAMCFG=0x0)
HPWR_21			3.3V	—	1578	μA	RTC is running on XOSC32K Full System RAM retained (PM.HIBCFG.RAMCFG=0x0)
HPWR_23			1.8V	—	1574	μA	8 KB backup RAM retained (PM.HIBCFG.BRAMCFG=0x0)

.....continued

DC CHARACTERISTICS				Standard Operating Conditions: VDD = AVDD = 1.71V to 3.63V (unless otherwise stated) Operating temperature: -40°C ≤ T <sub>A</sub> ≤ +125°C for Extended Temperature			
Param. No.	Symbol	Characteristics	VDD	Typ.	Max.	Units	Conditions
HPWR_25	I <sub>DD_HIBERNATE</sub>	BUCK mode selected	3.3V	—	221	μA	No peripheral running. No System RAM retained (PM.HIBCFG.RAMCFG=0x2)
HPWR_27			1.8V	—	216	μA	No backup RAM retained (PM.HIBCFG.BRAMCFG=0x2)
HPWR_29			3.3V	—	223	μA	RTC is running on XOSC32K No System RAM retained (PM.HIBCFG.RAMCFG=0x2)
HPWR_31			1.8V	—	217	μA	No backup RAM retained (PM.HIBCFG.BRAMCFG=0x2)
HPWR_33			3.3V	—	250	μA	RTC is running on XOSC32K No System RAM retained (PM.HIBCFG.RAMCFG=0x2)
HPWR_35			1.8V	—	244	μA	4 KB backup RAM retained (PM.HIBCFG.BRAMCFG=0x1)
HPWR_37			3.3V	—	279	μA	RTC is running on XOSC32K No System RAM retained (PM.HIBCFG.RAMCFG=0x2)
HPWR_39			1.8V	—	273	μA	8 KB backup RAM retained (PM.HIBCFG.BRAMCFG=0x0)
HPWR_41			3.3V	—	434	μA	RTC is running on XOSC32K 32 KB System RAM retained (PM.HIBCFG.RAMCFG=0x1)
HPWR_43			1.8V	—	430	μA	8 KB backup RAM retained (PM.HIBCFG.BRAMCFG=0x0)
HPWR_45			3.3V	—	1084	μA	RTC is running on XOSC32K Full System RAM retained (PM.HIBCFG.RAMCFG=0x0)
HPWR_47			1.8V	—	1061	μA	8 KB backup RAM retained (PM.HIBCFG.BRAMCFG=0x0)

**Notes:**

- Conditions:
  - No peripheral modules are operating (i.e. all peripherals inactive)
  - MCLK all APB clock masked except MCLK and NVMCTRL
  - MCLK.AHBMASK = 0x00C00FFF
  - BOD33 is disabled
  - I/Os are inactive input mode with input trigger disabled
  - All clock generation sources disabled unless otherwise specified
  - WDT, CFD Clock Fail Detect disabled
  - $\overline{\text{RESET}} = \text{VDD}$
- For the PIC32CX SG60/SG61 variants, the current consumption of the HSM is not taken into account and must be added according to its operating mode. Refer to the "PIC32CX SG60/SG61 Hardware Security Module Addendum (DS60001750)" for additional information.

## 56.8 MCU Backup Current Consumption

**Table 56-9.** MCU Backup Current Consumption Electrical Specifications <sup>(1,2)</sup>

DC CHARACTERISTICS				Standard Operating Conditions: VDD = AVDD = 1.71V to 3.63V (unless otherwise stated) Operating temperature: -40°C ≤ T <sub>A</sub> ≤ +125°C for Extended Temperature			
Param. No.	Symbol	Characteristics	VDD or VBAT	Min.	Max.	Units	Conditions
BPWR_1	I <sub>DD_BACKUP</sub>	Backup powered from VDD	VDD = 3.3V	—	308	μA	No RTC, No XOSC32 running No backup RAM retained (PM.BKUPCFG.BRAMCFG=0x2) BOD33 disabled
BPWR_3			VDD = 1.8V	—	304	μA	
BPWR_5			VDD = 3.3V	—	310	μA	RTC running on XOSC32K No backup RAM retained (PM.BKUPCFG.BRAMCFG=0x2) BOD33 disabled
BPWR_7			VDD = 1.8V	—	305	μA	
BPWR_9			VDD = 3.3V	—	349	μA	No RTC running, No XOSC32 running 4 KB backup RAM retained (PM.BKUPCFG.BRAMCFG = 0x1) BOD33 disabled
BPWR_11			VDD = 1.8V	—	345	μA	
BPWR_13			VDD = 3.3V	—	390	μA	No RTC, No XOSC32 8 KB backup RAM retained (PM.BKUPCFG.BRAMCFG=0x0) BOD33 disabled
BPWR_15			VDD = 1.8V	—	385	μA	
BPWR_17			I <sub>DD_BACKUP</sub>	Backup powered from VBAT	VBAT=3.3V	—	309
BPWR_19	VBAT(min)	—			304	μA	
BPWR_21	VBAT=3.3V	—			310	μA	RTC running on XOSC32K No backup RAM retained (PM.BKUPCFG.BRAMCFG=0x2) BOD33 enabled in sampled mode PSEL prescaler set to 0x7 (div 256)
BPWR_23	VBAT(min)	—			305	μA	
BPWR_25	VBAT=3.3V	—			350	μA	No RTC, No XOSC32 running 4 KB backup RAM retained (PM.BKUPCFG.BRAMCFG=0x1) BOD33 enabled in sampled mode PSEL prescaler set to 0x7 (div 256)
BPWR_27	VBAT(min)	—			345	μA	
BPWR_29	VBAT=3.3V	—			391	μA	No RTC, No XOSC32 running 8 KB backup RAM retained (PM.BKUPCFG.BRAMCFG=0x0) BOD33 enabled in sampled mode PSEL prescaler set to 0x7 (div 256)
BPWR_31	VBAT(min)	—			386	μA	

.....continued

DC CHARACTERISTICS				Standard Operating Conditions: VDD = AVDD = 1.71V to 3.63V (unless otherwise stated) Operating temperature: -40°C ≤ T <sub>A</sub> ≤ +125°C for Extended Temperature			
--------------------	--	--	--	--	--	--	--

Param. No.	Symbol	Characteristics	VDD or VBAT	Min.	Max.	Units	Conditions
------------	--------	-----------------	-------------	------	------	-------	------------

**Notes:**

1. Conditions:
  - No peripheral modules are operating (i.e. all peripherals inactive)
  - MCLK all APB clock masked except MCLK and NVMCTRL
  - MCLK.AHBMASK = 0x00C00FFF
  - BOD33 is disabled unless noted
  - I/Os are inactive input mode with input trigger disabled
  - All clock generation sources disabled unless otherwise specified
  - WDT, CFD Clock Fail Detect disabled
  - $\overline{\text{RESET}} = \text{VDD}$
2. For the PIC32CX SG60/SG61 variants, the current consumption of the HSM is not taken into account and must be added according to its operating mode. Refer to the "PIC32CX SG60/SG61 Hardware Security Module Addendum (DS60001750)" for additional information.

## 56.9 MCU Off Current Consumption

**Table 56-10.** MCU Off Current Consumption Electrical Specifications <sup>(1,2)</sup>

DC CHARACTERISTICS				Standard Operating Conditions: VDD = AVDD = 1.71V to 3.63V (unless otherwise stated) Operating temperature: -40°C ≤ T <sub>A</sub> ≤ +125°C for Extended Temperature			
Param. No.	Symbol	Characteristics	VDD	Typ.	Max.	Units	Conditions
OPWR_1			3.3V	—	32	μA	In Off mode, the device is entirely powered-off. (SLEEP_CFG.SLEEP_MODE=OFF), and subsequent execution of the WFI instruction. <b>Note:</b> This mode is left by pulling the RESET pin low, or when a power Reset is done.
OPWR_3	I <sub>DD_OFF</sub>	OFF mode powered from VDD	1.8V	—	27	μA	

**Notes:**

- Conditions:
  - All peripherals inactive unless otherwise specified
  - All clock generation sources disabled unless otherwise specified
  - All I/O pins configured as input pins pulled down or tied to VSS/AVSS
- For the PIC32CX SG60/SG61 variants, the current consumption of the HSM is not taken into account and must be added according to its operating mode. Refer to the "PIC32CX SG60/SG61 Hardware Security Module Addendum (DS60001750)" for additional information.

## 56.10 Peripheral Active Current

**Table 56-11.** Peripheral Active Current Electrical Specifications <sup>(1)</sup>

DC CHARACTERISTICS			Standard Operating Conditions: VDD = AVDD = 1.71V to 3.63V (unless otherwise stated) Operating temperature: -40°C ≤ T <sub>A</sub> ≤ +125°C for Extended Temperature
Param. No.	Symbol	Characteristics	Conditions
<b>MODULES/PERIPHERALS ACTIVE CURRENTS ≤ 5μA</b>			
PAI_1	BOD_IDD_STBY_HIB	BOD Standby low pwr / Hiberate (1 of 3)	Standby with BOD continuous low power mode or Hibernate mode
PAI_3	XOSC32K	32 kHz Crystal Oscillator	
<b>MODULES/PERIPHERALS ACTIVE CURRENTS ≤ 10μA</b>			
PAI_11	BOD_IDD_STBY_NORM	BOD Standby normal mode (2 of 3)	Standby with BOD continuous normal mode
<b>MODULES/PERIPHERALS ACTIVE CURRENTS ≤ 25μA</b>			
PAI_51	BOD_IDD_ACT_IDLE	BOD Active / Idle (3 of 3)	Active / Idle Mode, Standby Continuous mode
PAI_100	AC_VSCALE_IDD	Comparator Voltage Scaler module IDD	
<b>MODULES/PERIPHERALS ACTIVE CURRENTS ≤ 100μA</b>			
PAI_400	AC_IDD	Analog Comparator IDD	COMPCTRLn.SPEED=0x3, AVDD=3.3V COMPCTRLn.HYSTEN=0, Hysteresis disabled Voltage scaler disabled
<b>MODULES/PERIPHERALS ACTIVE CURRENTS ≤ 450μA</b>			
PAI_900	DAC_IDD (1 of 4)	DAC operating current	DAC Single ended mode, fs = 10 ksp/s, AVDD = 3.3V

.....continued

DC CHARACTERISTICS			Standard Operating Conditions: VDD = AVDD = 1.71V to 3.63V (unless otherwise stated) Operating temperature: -40°C ≤ T <sub>A</sub> ≤ +125°C for Extended Temperature
Param. No.	Symbol	Characteristics	Conditions
<b>MODULES/PERIPHERALS ACTIVE CURRENTS ≤ 550µA</b>			
PAI_950	DAC_IDD (2 of 4)	DAC operating current	DAC Differential mode, fs = 10 ksp/s, AVDD = 3.3V
PAI_953	DAC_IDD (3 of 4)	DAC operating current	DAC Single ended mode, fs = 1 Msps, AVDD = 3.3V
<b>MODULES/PERIPHERALS ACTIVE CURRENTS ≤ 1mA</b>			
PAI_1000	DAC_IDD (4 of 4)	DAC operating current	DAC Differential mode, fs = 1 Msps, AVDD = 3.3V
PAI_955	ADC_IDD (1 of 2)	ADC operating current	Single-Ended Mode, fs = 1 Msps, REFCTRL.REFSEL = 0x3, VREF = AVDD = 3.3V
PAI_1001	ADC_IDD (2 of 2)	ADC operating current	Differential Mode, fs = 1 Msps, REFCTRL.REFSEL = 0x3, VREF = AVDD = 3.3V
<b>MODULES/PERIPHERALS ACTIVE CURRENTS ≤ 1.5 mA</b>			
PAI_80004	TC_IDD	TC operating current	TC GCLK clock at 120MHz from DPLL, VDD = 3.3V
PAI_80002	I2S_IDD	I2S operating current	I2S GCLK clock at 120MHz from DPLL, VDD = 3.3V
PAI_80006	PDEC_IDD	PDEC operating current	PDEC GCLK clock at 120MHz from DPLL, VDD = 3.3V
<b>MODULES/PERIPHERALS ACTIVE CURRENTS ≤ 2.5 mA</b>			
PAI_4001	XOSC_IDD (1 of 4)	XOSC oscillator current consumption	Freq crystal 8-to-32Mhz, ENALC = ON
PAI_2000	DFLL48M_IDD	48Mhz Digital Frequency Locked Loop	Open Loop mode - DFLLVAL after reset VDD = 3.3V, Closed Loop mode - fREF = 32.768 kHz VDD = 3.3V
PAI_8000	FDPLL_IDD (1 of 2)	Fractional Digital Phase Lock Loop current	Clk = 96 MHz, VDD = 3.3V
PAI_80003	PCC_IDD	PCC operating current	PCC GCLK clock at 120MHz from DPLL, VDD = 3.3V
PAI_80005	TCC_IDD	TCC operating current	TCC GCLK clock at 120MHz from DPLL, VDD = 3.3V
<b>MODULES/PERIPHERALS ACTIVE CURRENTS ≤ 5 mA</b>			
PAI_4000	PTC_IDD	PTC, Peripheral Touch Controller, current	PTC running at 4 MHz, Mutual-Capacitance mode, One touch channel, Standby Sleep mode enabled, RTC running on ULP32K: used to define the PTC scan rate, through the event system, RTC interrupts (wake up) the CPU to perform PTC scans
PAI_4002	XOSC_IDD (2 of 4)	XOSC oscillator current consumption	Freq crystal 48Mhz, ENALC = ON
PAI_4003	XOSC_IDD (3 of 4)	XOSC oscillator current consumption	Freq crystal 8-to-16Mhz, ENALC = OFF
PAI_8001	FDPLL_IDD (2 of 2)	Fractional Digital Phase Lock Loop current	Clk = 200 MHz, VDD = 3.3V
<b>MODULES/PERIPHERALS ACTIVE CURRENTS ≤ 8 mA</b>			

.....continued

DC CHARACTERISTICS			Standard Operating Conditions: VDD = AVDD = 1.71V to 3.63V (unless otherwise stated) Operating temperature: -40°C ≤ T <sub>A</sub> ≤ +125°C for Extended Temperature
Param. No.	Symbol	Characteristics	Conditions
PAI_4004	XOSC_IDD (4 of 4)	XOSC oscillator current consumption	Freq crystal 32-to-48Mhz, ENALC = OFF
PAI_40000	FLASH_IDD	Flash Erase and Programming Current	Flash Erase and Programming Current
PAI_80007	USB_IDD	USB operating current	USB GCLK from DFLL48M in clock recovery mode USB device attached to active USB Host
PAI_80000	GMAC_IDD	Ethernet operating current	GMAC running on system clock at 120MHz in MII or RMII mode, VDD = 3.3V

**Note:**  
1. These values are for worst case guidance only unless otherwise specified, actual values depend on user peripheral configuration and operating frequency.

## 56.11 I/O Pin Electrical Specifications

Table 56-12. I/O Pin Electrical Specifications

AC/DC CHARACTERISTICS			Standard Operating Conditions: VDD = AVDD = 1.71V to 3.63V (unless otherwise stated) Operating temperature: -40°C ≤ T <sub>A</sub> ≤ +125°C for Extended Temperature				
Param. No.	Symbol	Characteristics	Min.	Typ.	Max.	Units	Conditions
DI_23	∑ <sub>IICT</sub>	Total Input Injection Current (sum of all I/O and control pins) Absolute value of   ∑IICT	-18	—	18	mA	Absolute instantaneous sum of all ± input injection currents from all I/O pins. (   IICL   +   IICH   ) ≤ ∑IICT

## 56.12 Maximum Clock Frequencies Electrical Specifications

**Table 56-13.** Maximum Clock Frequencies Electrical Specifications

AC CHARACTERISTICS		Standard Operating Conditions: VDD = AVDD = 1.71V to 3.63V (unless otherwise stated) Operating temperature: -40°C ≤ T <sub>A</sub> ≤ +125°C for Extended Temperature		
Param. No.	Symbol	Characteristics	Max	Units
FCLK_1	fCPU	CPU clock freq	100	MHz
FCLK_3	fAHB	AHB clock freq	100	MHz
FCLK_5	fAPBx	APBA, APBB, APBC, APBD clock freq	100	MHz
FCLK_6	fHS	High Speed (HS) clock freq	132	MHz
FCLK_7	fGCLK_DPLLx	FDPLL0 and FDPLL1 reference clock freq	3.2	MHz
FCLK_9	fGCLK_DPLLx_32K	FDPLL0 and FDPLL1 32k reference clock freq	100	MHz
FCLK_11	fGCLK_DFLL48M_REF	DFLL48M reference clock freq	33	kHz
FCLK_13	fGCLK_EIC	EIC input clock freq	90	MHz
FCLK_15	fGCLK_FREQM_MSR	FREQM Measure Clock Frequency	180	MHz
FCLK_17	fGCLK_FREQM_REF	FREQM Reference Clock Frequency	90	MHz
FCLK_19	fGCLK_EVSYS_CHANNELx	EVSYS channel x input clock freq	90	MHz
FCLK_21	fGCLK_SERCOMx_SLOW	Common SERCOM slow input clock freq	12	MHz
FCLK_23	fGCLK_SERCOMx_CORE	SERCOMx input clock freq	90	MHz
FCLK_25	fGCLK_CANx	CAN input clock freq	90	MHz
FCLK_27	fGCLK_USB	USB input clock freq	60	MHz
FCLK_29	fGCLK_I2S	I2S input clock freq	90	MHz
FCLK_31	fGCLK_SDHCx_SLOW	Common SDHC slow input clock freq	12	MHz
FCLK_33	fGCLK_SDHCx_CORE	SDHCx input clock freq	150	MHz
FCLK_35	fGCLK_TCCx	TCCx input clock freq	180	MHz
FCLK_37	fGCLK_TCx	TC0, TC1, TC2, TC3 input clock freq	180	MHz
FCLK_39	fGCLK_TCx	TC4, TC5, TC6, TC7 input clock freq	100	MHz
FCLK_41	fGCLK_PDEC	PDEC input clock freq	180	MHz
FCLK_43	fGCLK_CCL	CCL input clock freq	90	MHz
FCLK_45	fGCLK_GCLKINx	External GCLKx input clock freq	50	MHz
FCLK_47	fGCLK_CM4_TRACE	Cortex-M4 Trace input clock freq	100	MHz
FCLK_49	fGCLK_AC	Analog comparator peripheral module clock freq	90	MHz
FCLK_51	fGCLK_ADCx	ADCx input clock freq	90	MHz
FCLK_53	fGCLK_DAC	DAC input clock freq	90	MHz



## 56.13 OSCULP32K Electrical Specifications

**Table 56-14.** Low Power Internal 32 kHz RC Oscillator Electrical Specifications

AC CHARACTERISTICS			Standard Operating Conditions: $V_{DD} = AV_{DD} = 1.71V$ to $3.63V$ (unless otherwise stated) Operating temperature: $-40^{\circ}C \leq T_A \leq +125^{\circ}C$ for Extended Temperature				
Param. No.	Symbol	Characteristics	Min.	Typ	Max.	Units	Conditions
LP32K_3	LPRC32K_ACC	Accuracy	-20.6	—	24.9	%	—

## 56.14 DFLL48M Electrical Specifications

**Table 56-15.** Digital Frequency Locked Loop (DFLL48M) Electrical Specifications

AC CHARACTERISTICS			Standard Operating Conditions: VDD = AVDD = 1.71V to 3.63V (unless otherwise stated) Operating temperature: -40°C ≤ T <sub>A</sub> ≤ +125°C for Extended Temperature				
Param. No.	Symbol	Characteristics	Min.	Typ	Max.	Units	Conditions
<b>DFLL48M (Open Loop)</b> <sup>(1,2)</sup>							
DFLL_1	DFLL_OL_F <sub>OUT</sub>	DFLL Open Loop Clock Frequency	45.57	48	50.63	MHz	LDO Mode
<b>Notes:</b>							
1. DFLL48 in open or close loop can be used only with LDO regulator.							
2. Not recommended for functional USB operation, SOF sync start-up only.							

## 56.15 FDPLL200M Electrical Specifications

**Table 56-16.** Frequency Digital Phase Locked Loop (FDPLL200M) Electrical Specifications

AC CHARACTERISTICS			Standard Operating Conditions: VDD = AVDD = 1.71V to 3.63V (unless otherwise stated) Operating temperature: -40°C ≤ T <sub>A</sub> ≤ +125°C for Extended Temperature				
Param. No.	Symbol	Characteristics	Min.	Typ	Max.	Units	Conditions
<b>FDPLL200M (Fractional Digital Phase Locked Loop) <sup>(1)</sup></b>							
FDPLL_5	FDPLL_Jitter <sup>(2)</sup>	FDPLL Period Jitter Pk-to-Pk	—	—	3	%	LDO Mode, fEXTERNAL=32.768kHz PPM≤100, fOUT(max)= 96MHz
			—	—	6	%	LDO Mode, fEXTERNAL=32.768kHz PPM≤100, fOUT(max)= 200MHz
			—	—	3.1	%	LDO Mode, fEXTERNAL=3.2MHz PPM≤100, fOUT(max)= 96MHz
			—	—	7.2	%	LDO Mode, fEXTERNAL=3.2MHz PPM≤100, fOUT(max)= 200MHz
FDPLL_11	FDPLL_SRT <sup>(2)</sup>	FDPLL Start-Up / Lock Time	—	—	100	μs	fEXTERNAL=3.2MHz PPM≤100,
<b>Notes:</b>							
1. FDPLL200M can be used only with LDO regulator.							
2. REFCLK for FDPLL200M is XOSC or XOSC32K.							

## 56.16 DAC Module Electrical Specifications

Table 56-17. DAC Module Electrical Specifications

AC CHARACTERISTICS			Standard Operating Conditions: VDD = AVDD = 1.71V to 3.63V (unless otherwise stated) Operating temperature: -40°C ≤ T <sub>A</sub> ≤ +125°C for Extended Temperature				
Param. No.	Symbol	Characteristics	Min.	Typ.	Max.	Units	Conditions
<b>DIFFERENTIAL MODE</b> (1,2,3,4)							
DDAC_19	INL	Integral Non Linearity	-4.1	—	4.1	LSB	1 Msps, External VREF REFSEL= VREFAB = 2.4V CTRLB.REFSEL[1:0] = 0x2, AVDD = VDD = 3.3V w/ CLOAD and RLOAD.
DDAC_21	DNL	Differential Non Linearity	-4.5	—	4.5	LSB	
DDAC_23	G <sub>ERR</sub>	Gain Error	-78	—	78	LSB	
DDAC_25	E <sub>OFF</sub>	Offset Error	-80.3	—	80.3	LSB	
<b>SINGLE ENDED MODE</b> (1,2,3,4)							
SDAC_19	INL	Integral Non Linearity	-6	—	6	LSB	1 Msps, External VREF REFSEL= VREFAB = 2.4V CTRLB.REFSEL[1:0] = 0x2, AVDD = VDD = 3.3V w/ CLOAD and RLOAD.
SDAC_21	DNL	Differential Non Linearity	-8.1	—	8.1	LSB	
SDAC_23	G <sub>ERR</sub>	Gain Error	-65.6	—	65.6	LSB	
SDAC_25	E <sub>OFF</sub>	Offset Error	-44.4	—	44.4	LSB	
<b>Notes:</b>							
1. DAC reference voltages < 2.4V, is not practical and peripheral performance is not guaranteed.							
2. DAC functional device operation with external VREF<2.4V is guaranteed, but not characterized. DAC will function, but with degraded performance. DAC accuracy is limited by users application noise/accuracy on AVDD, AVSS and VREF accuracy/drift.							
3. 12-bit mode.							
4. Over VOUT range defined by DAC_7 parameter.							

## 56.17 ADC Electrical Specifications

**Table 56-18.** ADC Single Ended Mode Electrical Specifications

AC CHARACTERISTICS			Standard Operating Conditions: VDD = AVDD = 1.71V to 3.63V (unless otherwise stated) Operating temperature: -40°C ≤ T <sub>A</sub> ≤ +125°C for Extended Temperature				
Param. No.	Symbol	Characteristics	Min.	Typ.	Max.	Units	Conditions
<b>SINGLE ENDED MODE ADC Accuracy <sup>(3)</sup></b>							
SADC_19	INL	Integral Nonlinearity	-3.3	—	3.3	LSB	1 Msps, Internal VREF=AVDD=VDD=3.3V
SADC_21			-5.1	—	5.1	LSB	1 Msps, External VREF=2.4V, AVDD=VDD=3.3V
SADC_27	DNL	Differential Nonlinearity	-1	—	1.5	LSB	1 Msps, External VREF=2.4V, AVDD=VDD=3.3V
SADC_37	EOFF	Offset Error	-26.1	—	11.6	LSB	1 Msps, Internal VREF=AVDD=VDD=3.3V, SAMPCTRL.OFFCOMP=1
			-35.9	—	29	LSB	1 Msps, External VREF=2.4V, AVDD=VDD=3.3V, SAMPCTRL.OFFCOMP=1
SADC_43	TUE	Total Unadjusted Error	-21	—	21	LSB	1 Msps, Internal VREF=AVDD=VDD=3.3v, REFCTRL.REFCOMP=1, SAMPCTRL.OFFCOMP=1
SADC_47			-19.7	—	19.7	LSB	1 Msps, External VREF=2.4V, AVDD=VDD=3.3V, REFCTRL.REFCOMP=1, SAMPCTRL.OFFCOMP=1
<b>SINGLE ENDED MODE ADC Dynamic Performance <sup>(3)</sup></b>							
SADC_49	SINAD <sup>(1,2)</sup>	Signal to Noise and Distortion	55.6	—	—	dB	VREF=AVDD=VDD=3.3V at 12bit max sampling rate
SADC_57	Nrms	Noise RMS	—	—	3	LSB	VREF = AVDD = VDD = 3.3V, Constant Input Voltage
			—	—	4	LSB	External VREF = 2.4V, AVDD = VDD = 3.3V, Constant Input Voltage
<b>Notes:</b>							
1. Characterized with an analog input sine wave = (FTP(max) / 100). Example: FTP(max)=1Msps/100 = 10kHz sine wave.							
2. Sinewave peak amplitude = 96% ADC_ Full Scale amplitude input with 12bit resolution.							
3. ADC is configured in 12bits mode, All registers are at the reset default value unless otherwise stated.							

**Table 56-19. ADC Differential Mode Electrical Specifications**

AC CHARACTERISTICS			Standard Operating Conditions: VDD = AVDD = 1.71V to 3.63V (unless otherwise stated) Operating temperature : -40°C ≤ T <sub>A</sub> ≤ +125°C for Extended Temperature				
Param. No.	Symbol	Characteristics	Min.	Typ.	Max.	Units	Conditions
<b>DIFFERENTIAL MODE ADC Accuracy <sup>(1)</sup></b>							
DADC_19	INL	Integral Nonlinearity	-1.8	—	1.8	LSB	1 Msps, Internal VREF=AVDD=VDD=3.3V
DADC_21			-1.9	—	1.9	LSB	1 Msps, External VREF=2.4V, AVDD=VDD=3.3V
DADC_27	DNL	Differential Nonlinearity	-1	—	1.2	LSB	1 Msps, External VREF=2.4V, AVDD=VDD=3.3V
DADC_31	GERR	Gain Error	-8.6	—	8.2	LSB	1 Msps, Internal VREF=AVDD=VDD=3.3V, REFCTRL.REFCOMP=1
			-5.4	—	8.6	LSB	1 Msps, External VREF=2.4V, AVDD=VDD=3.3V, REFCTRL.REFCOMP=1
			-12.3	—	8.2	LSB	1 Msps, Internal VREF=AVDD=VDD=3.3V, REFCTRL.REFCOMP=0
			-38.5	—	29.1	LSB	1 Msps, External VREF=2.4V, AVDD=VDD=3.3V, REFCTRL.REFCOMP=0
DADC_37	EOFF	Offset Error	-4.5	—	3.9	LSB	1 Msps, Internal VREF=AVDD=VDD=3.3V, SAMPCTRL.OFFCOMP=1
			-5.7	—	4.6	LSB	1 Msps, External VREF=2.4V, AVDD=VDD=3.3V, SAMPCTRL.OFFCOMP=1
			-15.3	—	15.3	LSB	1 Msps, Internal VREF=AVDD=VDD=3.3V, SAMPCTRL.OFFCOMP=0
			-20.9	—	21.2	LSB	1 Msps, External VREF=2.4V, AVDD=VDD=3.3V, SAMPCTRL.OFFCOMP=0
DADC_45	TUE	Total Unadjusted Error	-5.8	—	5.8	LSB	1 Msps, External VREF=2.4V, AVDD=VDD=3.3V, REFCTRL.REFCOMP=1, SAMPCTRL.OFFCOMP=1
<b>Note:</b>							
1. ADC is configured in 12bits mode, All registers are at the reset default value unless otherwise stated.							

**Table 56-20. ADC Conversion Electrical Requirements <sup>(2)</sup>**

AC CHARACTERISTICS			Standard Operating Conditions: VDD = AVDD = 1.71V to 3.63V (unless otherwise stated) Operating temperature: -40°C ≤ T <sub>A</sub> ≤ +15°C for Extended Temperature				
Param. No.	Symbol	Characteristics	Min.	Typ.	Max.	Units	Conditions
<b>ADC_Clock Requirements</b>							

.....continued

AC CHARACTERISTICS			Standard Operating Conditions: VDD = AVDD = 1.71V to 3.63V (unless otherwise stated) Operating temperature: -40°C ≤ T <sub>A</sub> ≤ +15°C for Extended Temperature				
Param. No.	Symbol	Characteristics	Min.	Typ.	Max.	Units	Conditions
ADC_57	TAD	ADC Clock Period	62.5	—	3125	ns	—
ADC_58	fGCLK_ADCx	ADCx Module GCLK max input freq	—	—	FCLK_51	MHz	FCLK_51: Refer to <a href="#">Maximum Clock Frequencies Electrical Specifications</a>
<b>ADC Single-Ended Throughput Rates</b>							
ADC_59	FTPR <sup>(1)</sup> (Single-Ended Mode)	Throughput Rate (Single-Ended)	24.62	—	1231	ksp/s	12-bit resolution, R <sub>source</sub> ≤ 147 Ω, SAMPCTRL.OFFCOMP=0, SAMPCTRL.SAMPLEN=0
			26.67	—	1333		10-bit resolution, R <sub>source</sub> ≤ 504 Ω, SAMPCTRL.OFFCOMP=0, SAMPCTRL.SAMPLEN=0
			32	—	1600		8-bit resolution, R <sub>source</sub> ≤ 1,000 Ω, SAMPCTRL.OFFCOMP=0, SAMPCTRL.SAMPLEN=0
			20	—	1000	ksp/s	12-bit resolution, R <sub>source</sub> ≤ 6,560 Ω, SAMPCTRL.OFFCOMP=1, SAMPCTRL.SAMPLEN=n/a
			21.30	—	1067		10-bit resolution, R <sub>source</sub> ≤ 8,000 Ω, SAMPCTRL.OFFCOMP=1, SAMPCTRL.SAMPLEN=n/a
			24.62	—	1231		8-bit resolution, R <sub>source</sub> ≤ 9,984 Ω, SAMPCTRL.OFFCOMP=1, SAMPCTRL.SAMPLEN=n/a
<b>ADC Differential Mode Throughput Rates</b>							

.....continued

AC CHARACTERISTICS			Standard Operating Conditions: VDD = AVDD = 1.71V to 3.63V (unless otherwise stated) Operating temperature: -40°C ≤ T <sub>A</sub> ≤ +15°C for Extended Temperature				
Param. No.	Symbol	Characteristics	Min.	Typ.	Max.	Units	Conditions
ADC_61	FTPR <sup>(1)</sup> (Differential Mode)	Throughput Rate (Differential Mode)	24.62	—	1231	ksps	12-bit resolution, R <sub>source</sub> ≤ 147 Ω, SAMPCTRL.OFFCOMP=0, SAMPCTRL.SAMPLEN=0
			29.09	—	1455		10-bit resolution, R <sub>source</sub> ≤ 504 Ω, SAMPCTRL.OFFCOMP=0, SAMPCTRL.SAMPLEN=0
			35.56	—	1778		8-bit resolution, R <sub>source</sub> ≤ 1,000 Ω, SAMPCTRL.OFFCOMP=0, SAMPCTRL.SAMPLEN=0
			20	—	1000	ksps	12-bit resolution, R <sub>source</sub> ≤ 6,560 Ω SAMPCTRL.OFFCOMP=1, SAMPCTRL.SAMPLEN=n/a
			22.86	—	1143		10-bit resolution, R <sub>source</sub> ≤ 8,000 Ω SAMPCTRL.OFFCOMP=1, SAMPCTRL.SAMPLEN=n/a
			26.67	—	1333		8-bit resolution, R <sub>source</sub> ≤ 9,984 Ω SAMPCTRL.OFFCOMP=1, SAMPCTRL.SAMPLEN=n/a

**Notes:**

- ADC Throughput Rate FTP = ((1 / ((TSAMP + TCNV) \* TAD)) / (# of user active analog inputs in use on specific target ADC module)).  
**Note:** Specification values assume only one AINx channel in use.
- These values are based on simulation, and not covered by production test limits or characterization.



## 56.18 AC Electrical Specifications

Table 56-21. Comparator Electrical Specifications

AC CHARACTERISTICS			Standard Operating Conditions: VDD = AVDD = 1.71V to 3.63V (unless otherwise stated) Operating temperature: -40°C ≤ TA ≤ +125°C for Extended Temperature				
Param. No.	Symbol	Characteristics	Min.	Typ.	Max.	Units	Conditions
CMP_1	VIOFF	Input Offset Voltage	-17	—	17	mV	COMPCTRLn.SPEED = 0x3
			-26	—	26		COMPCTRLn.SPEED = 0x0
CMP_5	VHYST_00	Input Hysteresis Voltage	12	—	47	mV	COMPCTRLn.SPEED = 0x3 COMPCTRLn.HYSTEN = 0x1 COMPCTRLn.HYST = 0x0
			3	—	42	mV	COMPCTRLn.SPEED = 0x0 COMPCTRLn.HYSTEN = 0x1 COMPCTRLn.HYST = 0x0
	VHYST_01	Input Hysteresis Voltage	28	—	80	mV	COMPCTRLn.SPEED = 0x3 COMPCTRLn.HYSTEN = 0x1 COMPCTRLn.HYST = 0x1
			18	—	64	mV	COMPCTRLn.SPEED = 0x0 COMPCTRLn.HYSTEN = 0x1 COMPCTRLn.HYST = 0x1
	VHYST_02	Input Hysteresis Voltage	36	—	114	mV	COMPCTRLn.SPEED = 0x3 COMPCTRLn.HYSTEN = 0x1 COMPCTRLn.HYST = 0x2
			30	—	91	mV	COMPCTRLn.SPEED = 0x0 COMPCTRLn.HYSTEN = 0x1 COMPCTRLn.HYST = 0x2
	VHYST_03	Input Hysteresis Voltage	61	—	148	mV	COMPCTRLn.SPEED = 0x3 COMPCTRLn.HYSTEN = 0x1 COMPCTRLn.HYST = 0x3
			42	—	120	mV	COMPCTRLn.SPEED = 0x0 COMPCTRLn.HYSTEN = 0x1 COMPCTRLn.HYST = 0x3
CMP_15	TRESP <sub>SS</sub> <sup>(2)</sup>	Small Signal Response Time - High speed	—	—	41	ns	COMPCTRLn.SPEED = 0x3 COMPCTRLn.HYSTEN = 0x0 Comparator ref voltage = AVDD/2. Input overdrive = +/- 100mV
		Small Signal Response Time - Low Speed	—	—	95	ns	COMPCTRLn.SPEED = 0x0 COMPCTRLn.HYSTEN = 0x0 Comparator ref voltage = AVDD/2. Input overdrive = +/- 100mV
CMP_19	C <sub>OUTVAL</sub>	Comparator Enabled to Output Valid - High Speed	—	—	7.2	ms	Comparator module is configured before enabling it COMPCTRLn.SPEED = 0x3
		Comparator Enabled to Output Valid - Low Speed	—	—	14.1	ms	Comparator module is configured before enabling it COMPCTRLn.SPEED = 0x0
CMP_23	C <sub>VREFRNG</sub>	Comparator Voltage Reference Input Range	-2	—	AVDD - 0.2V or Note <sup>(1)</sup> , whichever is lower	V	-

.....continued

AC CHARACTERISTICS			Standard Operating Conditions: VDD = AVDD = 1.71V to 3.63V (unless otherwise stated) Operating temperature: -40°C ≤ T <sub>A</sub> ≤ +125°C for Extended Temperature				
Param. No.	Symbol	Characteristics	Min.	Typ.	Max.	Units	Conditions
CMP_25	F <sub>GCLK_AC</sub>	Analog comparator peripheral module clock freq	—	—	FCLK_49	MHz	FCLK_49: Refer to <a href="#">Maximum Clock Frequencies Electrical Specifications</a>

**Notes:**

- Comparator Ref voltage cannot exceed: (VIN(max) - VIOFF(max) - CMP\_5(max) - 50mV) ≥ C<sub>VREFRNG</sub> ≥ (VIN(min) + abs(VIOFF(min)) + CMP\_5(max) + 50mV).
- TRESP<sub>SS</sub> is measured from VIN transition to ACOUT toggle (AC direct output accessible by setting COMPCTRLn.OUT[1:0]=0x1). It takes into account only analog propagation delay.

## 56.19 SPI Electrical Specifications

Figure 56-1. SPI Host Module (CPHA=0) Timing Diagrams

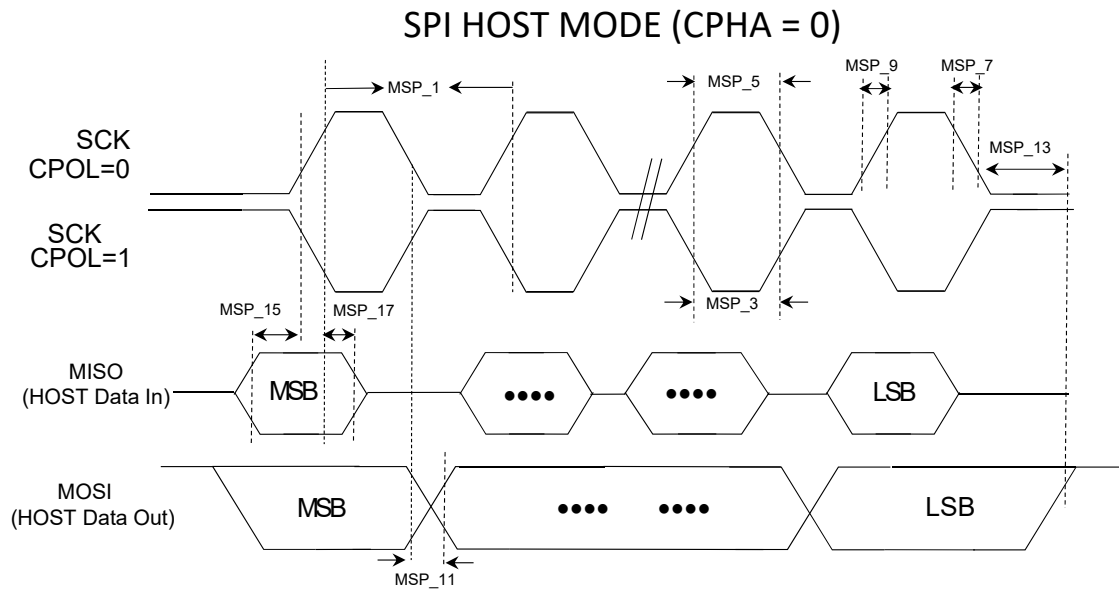
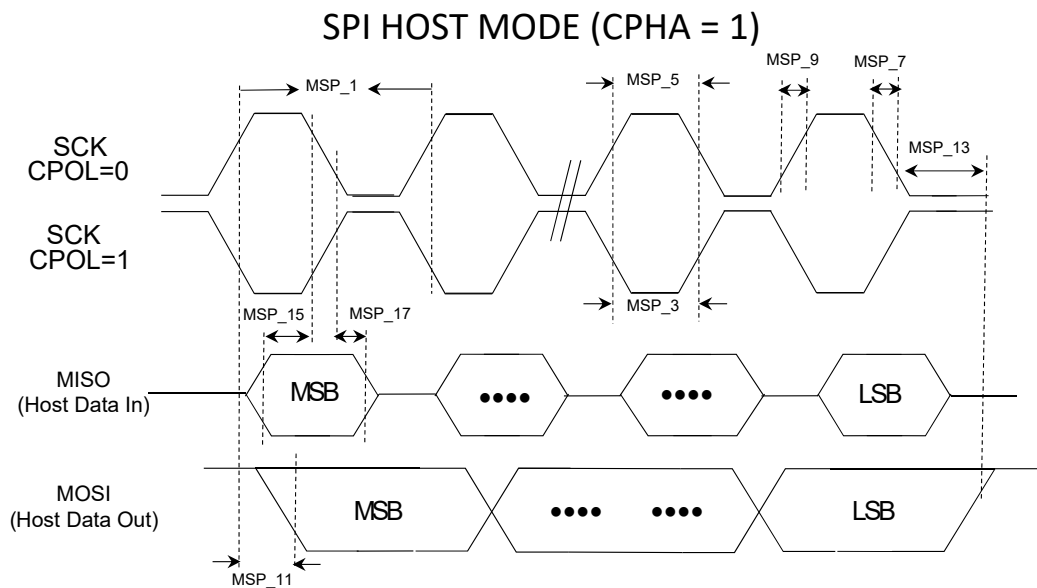


Figure 56-2. SPI Host Module (CPHA=1) Timing Diagrams



**Table 56-22.** SPI Module Host Mode Electrical Specifications <sup>(1)</sup>

AC CHARACTERISTICS			Standard Operating Conditions: VDD = AVDD = 1.71V to 3.63V (unless otherwise stated) Operating temperature: -40°C ≤ T <sub>A</sub> ≤ +125°C for Extended Temperature				
Param. No.	Symbol	Characteristics	Min.	Typ.	Max.	Units	Conditions
MSP_15	TMIS	MISO Setup Time of Data Input to SCK	19.5	—	—	ns	VDD(min), C <sub>LOAD</sub> =20pF <sub>(MAX)</sub>
MSP_19	SPI_GCLK	SERCOM SPI input clock freq, GCLK_SPI	—	—	FCLK_23	MHz	FCLK_23: Refer to <a href="#">Maximum Clock Frequencies Electrical Specifications</a>

**Note:**  
1. Assumes VDD(min) and 20pF external load on all SPIx pins unless otherwise noted.

Figure 56-3. SPI Client Module (CPHA=0) Timing Diagrams

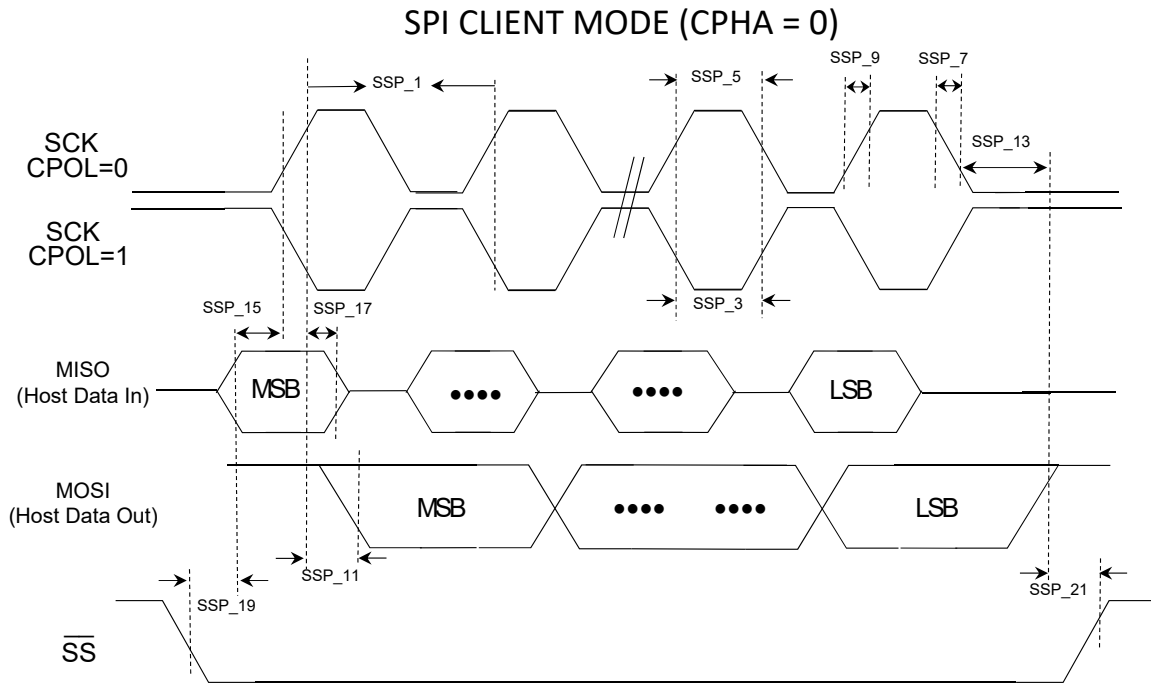
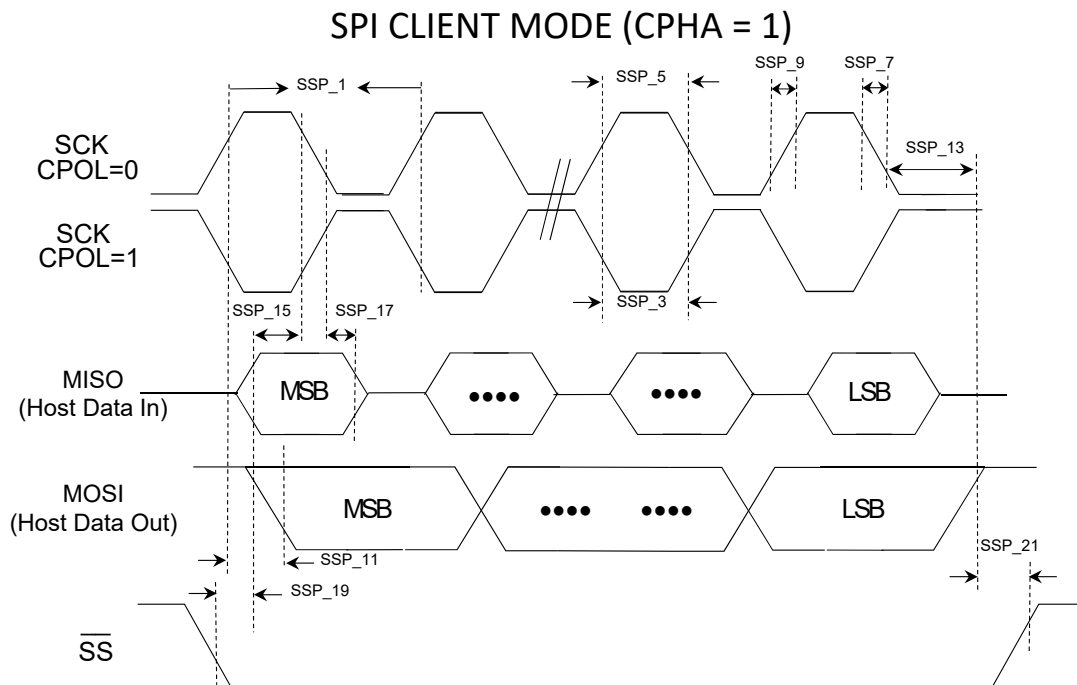


Figure 56-4. SPI Client Module (CPHA=1) Timing Diagrams



**Table 56-23.** SPI Module Client Mode Electrical Specifications <sup>(1)</sup>

AC CHARACTERISTICS			Standard Operating Conditions: VDD = AVDD = 1.71V to 3.63V (unless otherwise stated) Operating temperature: -40°C ≤ T <sub>A</sub> ≤ +125°C for Extended Temperature				
Param. No.	Symbol	Characteristics	Min.	Typ.	Max.	Units	Conditions
SSP_11	TSOV	MOSI Data Output Valid after SCK	—	—	16.5	ns	VDD(min), C <sub>LOAD</sub> =20pF <sub>(MAX)</sub>
SSP_15	TSIS	MISO Setup Time of Data Input to SCK	7.7	—	—	ns	FCLK_5: Refer to <a href="#">Maximum Clock Frequencies Electrical Specifications</a>
SSP_19	TSSS	SS setup to SCK (PRELOADEN=1)	(2/FCLK_5)+(1/FSCK)	—	—	ns	<a href="#">Maximum Clock Frequencies Electrical Specifications</a>
SSP_23	SPI_GCLK	SERCOM SPI input clock freq, GCLK_SPI	—	—	FCLK_23	MHz	FCLK_23: Refer to <a href="#">Maximum Clock Frequencies Electrical Specifications</a>

**Note:**  
1. Assumes VDD(min) and 20pF external load on all SPI pins unless otherwise noted.

## 56.20 USART Electrical Specifications

**Table 56-24.** USART Electrical Specifications

AC CHARACTERISTICS				Standard Operating Conditions: VDD = AVDD = 1.71V to 3.63V (unless otherwise stated) Operating temperature: -40°C ≤ T <sub>A</sub> ≤ +125°C for Extended Temperature				
Param. No.	Symbol	Characteristics		Min.	Typ.	Max.	Units	Conditions
UT_1	F <sub>BRATE</sub>	Baud Rate	Asynchronous SAMPR = 16x mode	—	—	FCLK_23/16	Mbps	VDD=1.8V or VDD=3.3V FCLK_23: Refer to <a href="#">Maximum Clock Frequencies Electrical Specifications</a>
UT_3			Asynchronous SAMPR = 8x mode	—	—	FCLK_23/8	Mbps	VDD=1.8V or VDD=3.3V FCLK_23: Refer to <a href="#">Maximum Clock Frequencies Electrical Specifications</a>
UT_5			Asynchronous SAMPR = 3x mode	—	—	FCLK_23/3	Mbps	VDD=1.8V or VDD=3.3V FCLK_23: Refer to <a href="#">Maximum Clock Frequencies Electrical Specifications</a>
UT_23	F <sub>USART</sub>	USART max GCLK_SERCOM		—	—	FCLK_23	MHz	FCLK_23: Refer to <a href="#">Maximum Clock Frequencies Electrical Specifications</a>

**Note:**  
1. These parameters are characterized, but not tested in manufacturing.

## 56.21 I<sup>2</sup>S Electrical Specifications

Figure 56-5. I<sup>2</sup>S Host Mode Timing Diagram

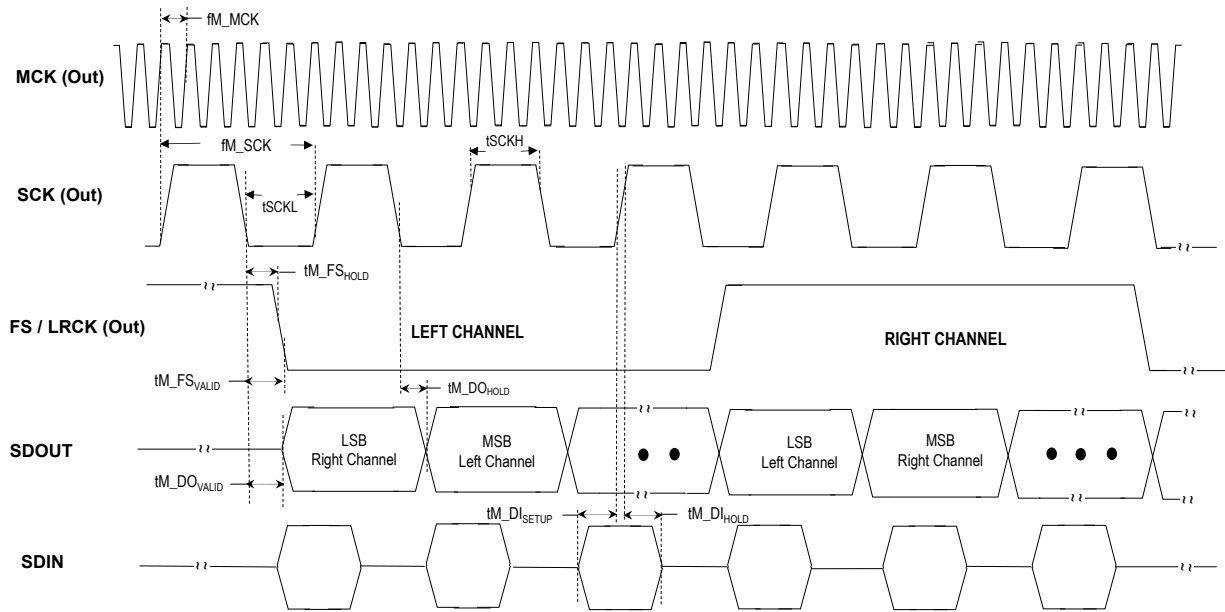


Table 56-25. I<sup>2</sup>S Host Mode Electrical Specifications

AC CHARACTERISTICS			Standard Operating Conditions: VDD = AVDD = 1.71V to 3.63V (unless otherwise stated) Operating temperature: -40°C ≤ T <sub>A</sub> ≤ +125°C for Extended Temperature				
Param. No.	Symbol	Characteristics	Min.	Typ.	Max.	Units	Conditions
I2S_11	f <sub>M_SCK</sub>	Host SCK Frequency			10.1	MHz	VDD=1.8V or VDD(min) whichever is greater, C <sub>LOAD</sub> =20pF(MAX)
			—	—	11.19		VDD=3.3V, C <sub>LOAD</sub> =20pF(MAX)
I2S_33	f <sub>GCLK_I2S</sub>	I <sup>2</sup> S Max GLK Input Clock Freq	—	—	FCLK_29	MHz	FCLK_29: Refer to <a href="#">Maximum Clock Frequencies Electrical Specifications</a>



Figure 56-6. I<sup>2</sup>S Client Mode Timing Diagram

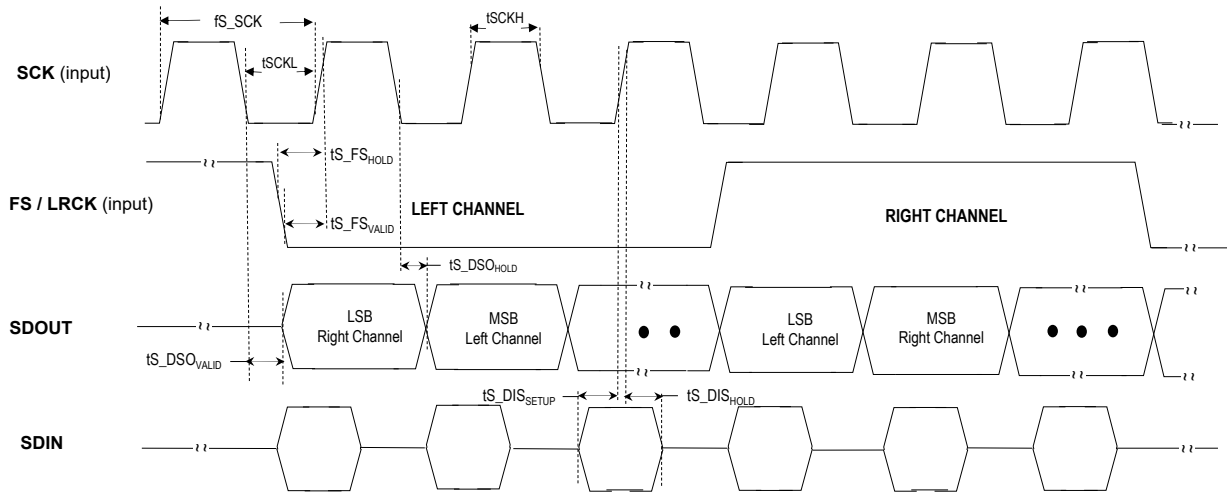


Table 56-26. I<sup>2</sup>S Client Mode Electrical Specifications

AC CHARACTERISTICS			Standard Operating Conditions: VDD = AVDD = 1.71V to 3.63V (unless otherwise stated) Operating temperature: -40°C ≤ T <sub>A</sub> ≤ +125°C for Extended Temperature				
Param. No.	Symbol	Characteristics	Min.	Typ.	Max.	Units	Conditions
I2S_41	f <sub>S_SCK</sub>	SCK Client Frequency	—	—	15.45	MHz	VDD=1.8V or VDD(min) whichever is greater, C <sub>LOAD</sub> =20pF(MAX)
			—	—	15.82		VDD=3.3V, C <sub>LOAD</sub> =20pF(MAX)
I2S_51	t <sub>S_DSOVALID</sub>	Data Output Client Valid	—	—	18	ns	VDD=1.8V or VDD(min) whichever is greater, C <sub>LOAD</sub> =20pF(MAX)
			—	—	13.2		VDD=3.3V, C <sub>LOAD</sub> =20pF(MAX)

## 56.22 QSPI Electrical Specifications

Figure 56-7. QSPI SDR Host Mode 0,1,2,3 Module Timing Diagram

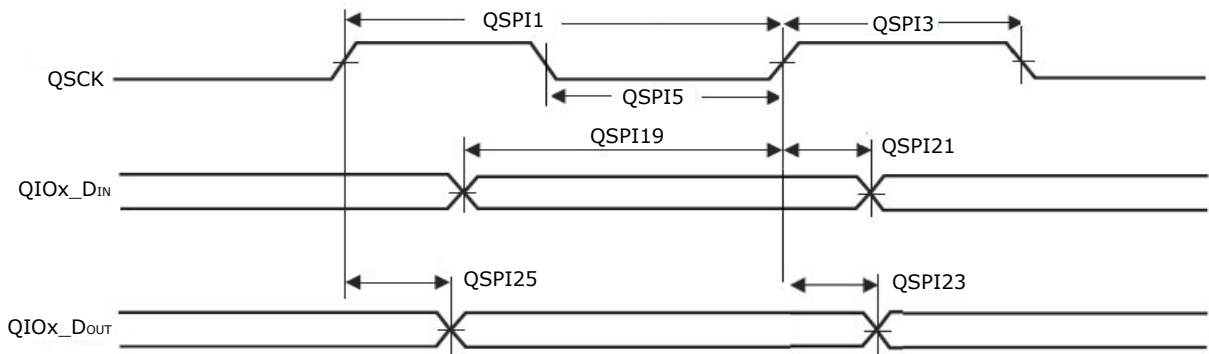


Figure 56-8. QSPI DDR Mode 0 Write Timing Diagram

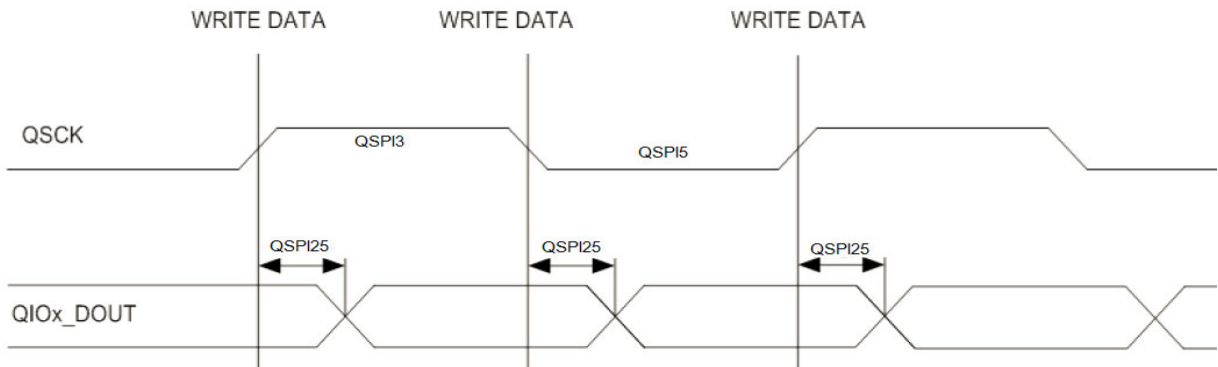
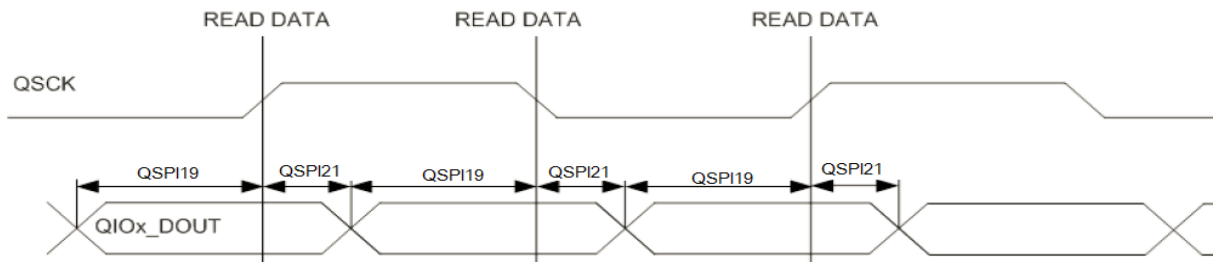


Figure 56-9. QSPI DDR Mode 0 Read Timing Diagram



**Table 56-27. QSPI Module Electrical Specifications** <sup>(1)</sup>

AC CHARACTERISTICS			Standard Operating Conditions: VDD = AVDD = 1.71V to 3.63V (unless otherwise stated) Operating temperature: -40°C ≤ T <sub>A</sub> ≤ +125°C for Extended Temperature				
Param. No.	Symbol	Characteristics	Min.	Typ.	Max.	Units	Conditions
QSPI_19	TDIS	Data In Setup Time	4.3	—	—	ns	VDD= 3.3V Host SDR mode 0
			4.71	—	—	ns	VDD= 3.3V Host SDR mode 1
			4.26	—	—	ns	VDD= 3.3V Host SDR mode 2
			4.73	—	—	ns	VDD= 3.3V Host SDR mode 3
			4.3	—	—	ns	VDD= 3.3V Host DDR mode 0
QSPI_25	TDOV	Data Out Valid	—	—	2.6	ns	VDD=3.3V Host SDR mode 0
			—	—	2.96	ns	VDD= 3.3V Host SDR mode 1
			—	—	2.43	ns	VDD= 3.3V Host SDR mode 2
			—	—	2.93	ns	VDD= 3.3V Host SDR mode 3
			—	—	2.45	ns	VDD= 3.3V Host DDR mode 0

**Note:**  
1. Assumes VDD(MAX) and 20pF external load on all QSPI pins unless otherwise noted.

**Table 56-28. QSPI Maximum Frequency Example** <sup>(1)</sup>

AC CHARACTERISTICS			Standard Operating Conditions: VDD = AVDD = 1.71V to 3.63V (unless otherwise stated) Operating temperature: -40°C ≤ T <sub>A</sub> ≤ +125°C for Extended Temperature			
QSPI Mode	CLK_QSPI2X_AHB	CLK_QSPI_AHB	Max. f <sub>CPU</sub>	Max. QSPI Serial Clock Frequency <sup>(2)</sup>	Conditions	
SDR	X	100 MHz	100 MHz	50 MHz	BAUD.BAUD[7:0] must be greater than 0 to ensure QSPI clock frequency is as per electrical specifications provided	
	X	75 MHz	75 MHz	75 MHz	-	
DDR	132 MHz	66 MHz	66 MHz	66 MHz	MCLK: HSDIV.DIV=0x01 MCLK: CPUDIV.DIV=0x02	

**Notes:**  
1. Examples shown do not supersede the electrical specification shown in QSPI Module Electrical Specifications table.  
2. Refer to QSPI\_1 for maximum QSPI Serial Clock Frequency (FCLK) in SDR and DDR modes.

## 56.23 CAN Electrical Specifications

Figure 56-10. CAN Module Timing Diagram

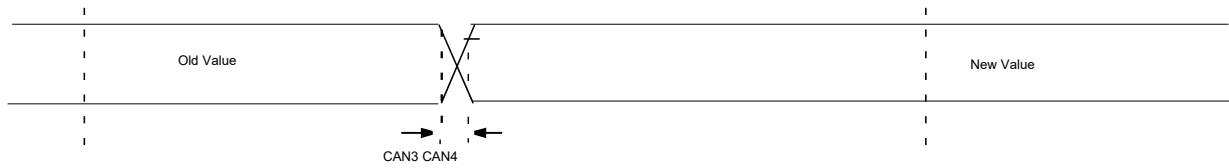


Table 56-29. CAN Module Electrical Specifications

AC CHARACTERISTICS			Standard Operating Conditions: VDD = AVDD = 1.71V to 3.63V (unless otherwise stated) Operating temperature : -40°C ≤ T <sub>A</sub> ≤ +125°C for Extended Temperature				
Param. No.	Symbol	Characteristics	Min.	Typ.	Max.	Units	Conditions
CAN_7	fCAN_GCLK	CANx Input clock freq, GCLK_CAN	—	—	FCLK_25	MHz	FCLK_25: Refer to <a href="#">Maximum Clock Frequencies Electrical Specifications</a>

## 56.24 TC Electrical Specifications

Figure 56-11. TC Timer Capture Input Module Timing Diagrams

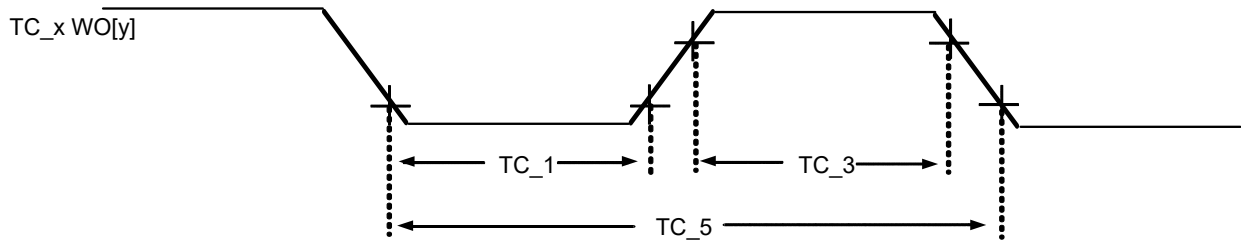


Figure 56-12. TC Timer Compare Output Module Timing Diagrams

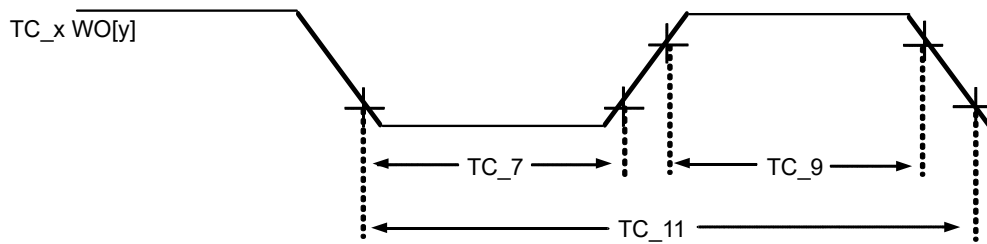


Table 56-30. TC Timer Capture Module Electrical Specifications

AC CHARACTERISTICS			Standard Operating Conditions: VDD = AVDD = 1.71V to 3.63V (unless otherwise stated) Operating temperature: -40°C ≤ T <sub>A</sub> ≤ +125°C for Extended Temperature				
Param. No.	Symbol	Characteristics	Min.	Typ.	Max.	Units	Conditions
TC_1	TC <sub>INLOW</sub>	Capture TCx Input Low Time	2/fGCLK_TCx	—	—	ns	VDD(min)
TC_3	TC <sub>INHIGH</sub>	Capture TCx Input High Time	2/fGCLK_TCx	—	—	ns	VDD(min)
TC_5	TC <sub>INPERIOD</sub>	Capture Input Period	4/fGCLK_TCx	—	—	ns	VDD(min)
TC_13	f <sub>GCLK_TCx</sub>	TC peripheral module clock frequency	—	—	FCLK_37	MHz	VDD(min), for TC0,1,2,3 FCLK_37: Refer to <a href="#">Maximum Clock Frequencies Electrical Specifications</a>
			—	—	FCLK_39	MHz	VDD(min), for TC4,5,6,7 FCLK_39: Refer to <a href="#">Maximum Clock Frequencies Electrical Specifications</a>

## 56.25 TCC Electrical Specifications

Figure 56-13. TCC Timer Capture Input Module Timing Diagrams

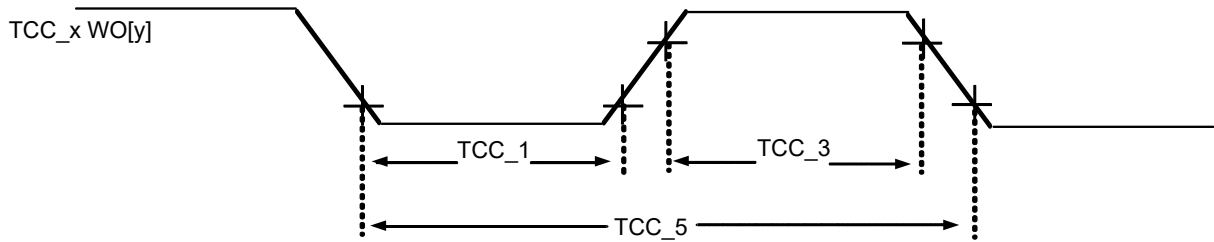


Figure 56-14. TCC Timer Compare Output Module Timing Diagrams

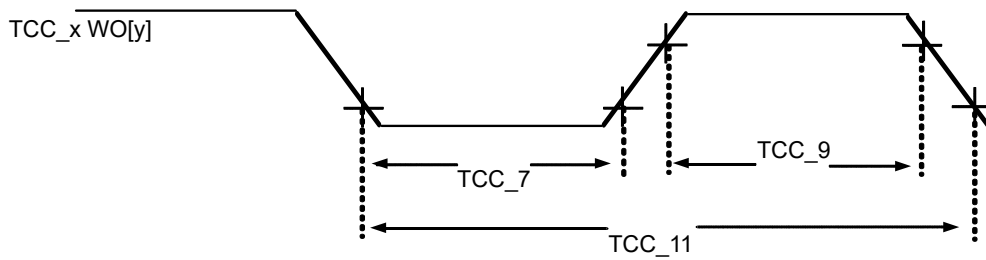
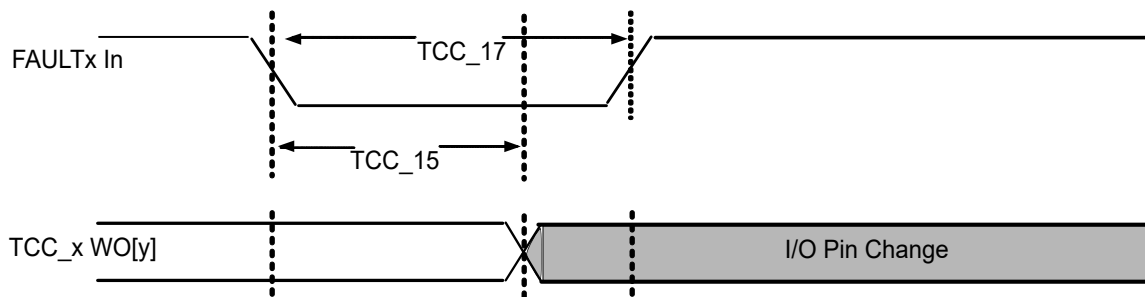


Figure 56-15. TCC Timer Compare Fault Output Module Timing Diagrams



**Table 56-31.** TCC Timer Capture Module Electrical Specifications

AC CHARACTERISTICS			Standard Operating Conditions: VDD = AVDD = 1.71V to 3.63V (unless otherwise stated) Operating temperature: -40°C ≤ T <sub>A</sub> ≤ +125°C for Extended Temperature				
Param. No.	Symbol	Characteristics	Min.	Typ.	Max.	Units	Conditions
TCC_1	TCC <sub>INLOW</sub>	Capture TCCx Input Low Time	2/fGCLK_TCCx	—	—	ns	VDD(min)
TCC_3	TCC <sub>INHIGH</sub>	Capture TCCx Input High Time	2/fGCLK_TCCx	—	—	ns	VDD(min)
TCC_5	TCC <sub>INPERIOD</sub>	Capture Input Period	4/fGCLK_TCCx	—	—	ns	VDD(min)
TCC_13	f <sub>GCLK_TCCx</sub>	TCC peripheral module clock frequency	—	—	FCLK_35	MHz	VDD(min) FCLK_35: Refer to <a href="#">Maximum Clock Frequencies Electrical Specifications</a>
TCC_15	TCC <sub>FD</sub>	Fault Input to I/O Pin Change	—	—	44	ns	VDD(min)

## 56.26 PCC Electrical Specifications

Figure 56-16. PCC Module Timing Diagram

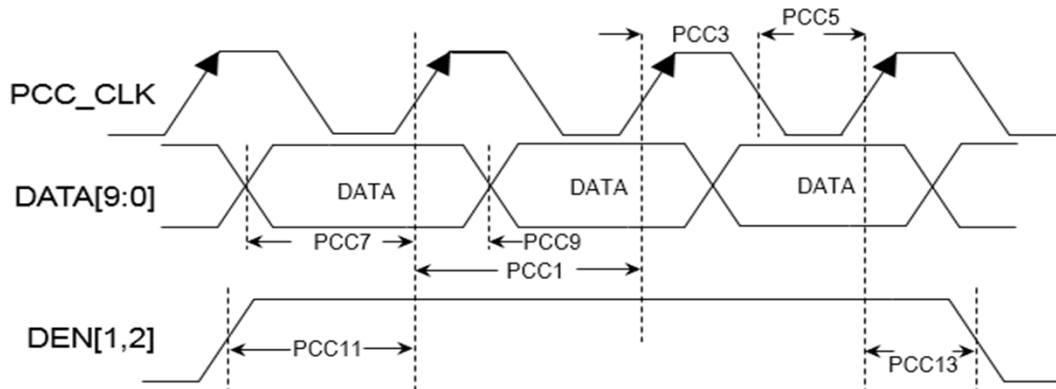


Table 56-32. PCC Electrical Specifications

AC CHARACTERISTICS			Standard Operating Conditions: VDD = AVDD = 1.71V to 3.63V (unless otherwise stated) Operating temperature: -40°C ≤ T <sub>A</sub> ≤ +125°C for Extended Temperature				
Param. No.	Symbol	Characteristics	Min.	Typ.	Max.	Units	Conditions
PCC_15	CLK_APB_PCC <sup>(1)</sup>	Internal MCLK PCC Module Clock	—	—	FCLK_5	MHz	VDD(min) FCLK_5: Refer to <a href="#">Maximum Clock Frequencies Electrical Specifications</a>
<b>Note:</b>							
1. CLK_APB_PCC ≥ (2 * PCC_1).							

## 56.27 NVM Block (Flash, Data Flash, NVM Configuration Rows) Electrical Specifications

Table 56-33. Flash NVM Electrical Specifications

AC CHARACTERISTICS			Standard Operating Conditions: VDD = AVDD = 1.71V to 3.63V (unless otherwise stated) Operating temperature: -40°C ≤ T <sub>A</sub> ≤ +125°C for Extended Temperature					
Param. No.	Symbol	Characteristics	Min.	Typ.	Max.	Units	Conditions	
NVM_5	F <sub>READ</sub> <sup>(1)</sup>	Flash Read	0 Wait States	—	—	19	MHz	CTRLA.AUTOWS=0
			1 Wait States	—	—	38		
			2 Wait States	—	—	57		
			3 Wait States	—	—	76		
			4 Wait States	—	—	95		
			5 Wait States	—	—	100		
<b>Note:</b>								
1. Maximum FLASH operating frequencies are given in the table above, but are limited by the Embedded Flash access time when the processor is fetching code out of it. These tables provide the device maximum operating frequency defined by the field RWS of the NVM_CTRL CTRLA register when automatic wait states (AUTOWS) is disabled. This field defines the number of Wait states required to access the Embedded Flash Memory.								



## 56.28 EEPROM Electrical Specifications

**Table 56-34.** EEPROM Electrical Specifications <sup>(1)</sup>

AC CHARACTERISTICS			Standard Operating Conditions: VDD = AVDD = 1.71V to 3.63V (unless otherwise stated) Operating temperature: -40°C ≤ T <sub>A</sub> ≤ +125°C for Extended Temperature					
Param. No.	Symbol	Characteristics	Min.	Typ.	Max.	Units	Conditions	
EEP_5	EE <sub>READ</sub>	EEPROM Read	0 Wait States	—	—	NVM_5	MHz	VDD=3.3V, NVMCTRL_CTRLA.AUTOWS ≥ 0
			1 Wait States	—	—	NVM_5		
			2 Wait States	—	—	NVM_5		
			3 Wait States	—	—	NVM_5		
			4 Wait States	—	—	NVM_5		
			5 Wait States	—	—	NVM_5		
<b>Note:</b>								
1. EEPROM parameters are dependent upon NVM parameters tied to SmartEEPROM emulation algorithm.								

## 56.29 FREQM Electrical Specifications

**Table 56-35.** Frequency Meter Electrical Specifications

AC CHARACTERISTICS			Standard Operating Conditions: VDD = AVDD = 1.71V to 3.63V (unless otherwise stated) Operating temperature: -40°C ≤ T <sub>A</sub> ≤ +125°C for Extended Temperature				
Param. No.	Symbol	Characteristics	Min.	Typ.	Max.	Units	Conditions
FM_7	f <sub>GCLK_FREQM_REF</sub>	FREQM Reference	—	—	FCLK_17	MHz	VDD(min)
FM_9	f <sub>GCLK_FREQM_MSR</sub>	FREQM Measure	—	—	FCLK_15	MHz	FCLK_15, FCLK_17: Refer to <a href="#">Maximum Clock Frequencies Electrical Specifications</a>

## 56.30 PDEC Electrical Specifications

Figure 56-17. Position Decoder (PDEC) Counter Mode Timing Diagram

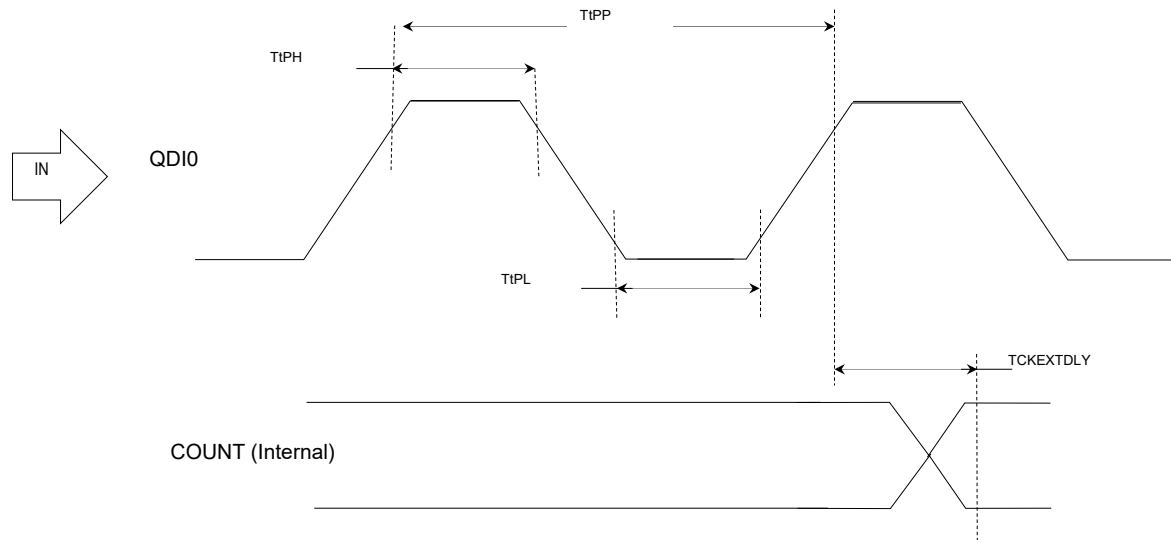
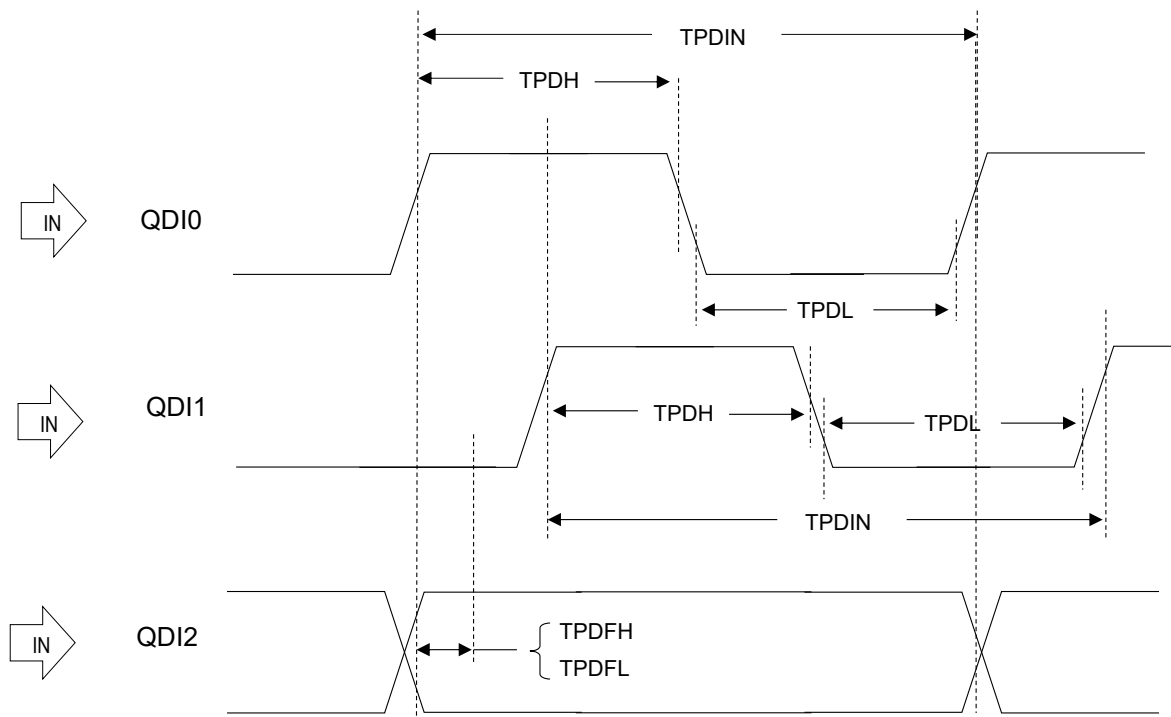


Figure 56-18. Position Decoder (PDEC) Input Timing Diagrams



**Table 56-36.** Quadrature Encoder Interface Electrical Specifications

AC CHARACTERISTICS			Standard Operating Conditions: VDD = AVDD = 1.71V to 3.63V (unless otherwise stated) Operating temperature: -40°C ≤ T <sub>A</sub> ≤ +125°C for Extended Temperature				
Param. No.	Symbol	Characteristics	Min.	Typ.	Max.	Units	Conditions
PDEC_1	TtPH	TPCK high time	2/fGCLK_PDEC	—	—	ns	FCLK_41: Refer to <a href="#">Maximum Clock Frequencies Electrical Specifications</a>
PDEC_3	TtPL	TPCK low time	2/fGCLK_PDEC	—	—	ns	
PDEC_5	TtPP	TPCK input period	4/fGCLK_PDEC	—	—	ns	
PDEC_7	TCKEXTDLY	Delay from External TxCK Clock Edge to counter Increment	—	—	4/fGCLK_PDEC	ns	
PDEC_11	TPDH	Position Decoder Input High Time	4/fGCLK_PDEC	—	—	ns	
PDEC_13	TPDL	Position Decoder Input Low Time	4/fGCLK_PDEC	—	—	ns	
PDEC_15	TPDIN	Position Decoder Input Period	8/fGCLK_PDEC	—	—	ns	
PDEC_21	TPDFH	Filter Time to Recognize High, with Digital Filter	4/fGCLK_PDEC	—	—	ns	
PDEC_23	TPDFL	Filter Time to Recognize Low, with Digital Filter	4/fGCLK_PDEC	—	—	ns	
PDEC_24	fGCLK_PDEC	GCLK_PDEC	—	—	FCLK_41	MHz	

## 57. Packaging Information

### 57.1 Package Marking Information

All devices are marked with the Microchip logo and the ordering code.

Where:

- **XXXXXX**: Part Number
- **YYWWNNN**: Trace Code
  - YY: Manufacturing Year (two last digit(s))
  - WW: Manufacturing Week
  - NNN: Internal Code

Figure 57-1. 64-pin TQFP



Figure 57-2. 100-pin TQFP



Figure 57-3. 100-pin TFBGA



Figure 57-4. 128-pin TQFP



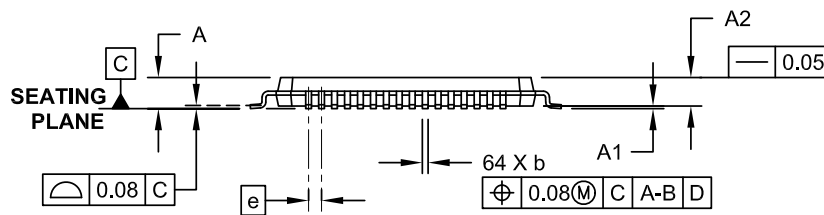
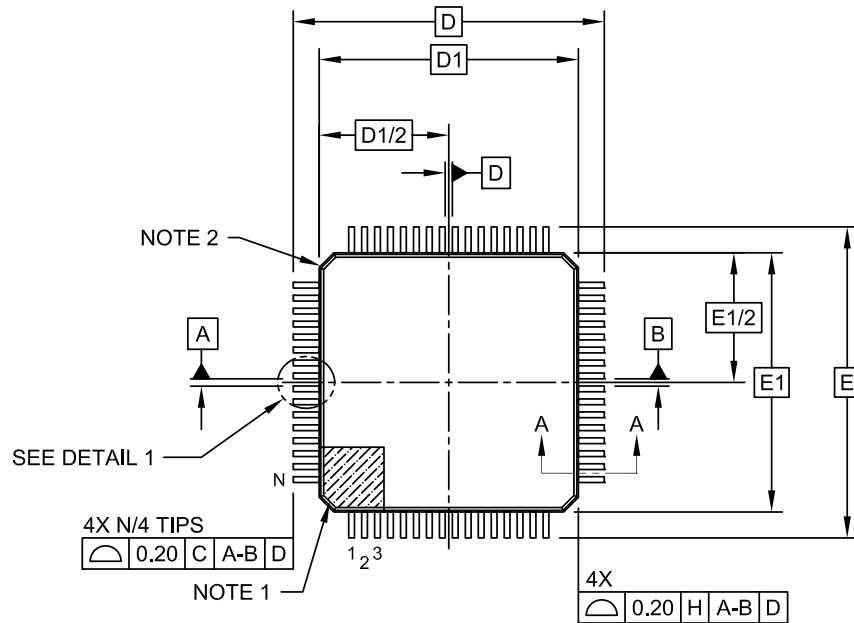
## 57.2 Package Drawings

For the most current package drawings, see the Microchip Packaging Specification located at [www.microchip.com/packaging](http://www.microchip.com/packaging).

### 57.2.1 64-pin TQFP

#### 64-Lead Plastic Thin Quad Flatpack (V2X)-10x10x1 mm Body, 2.00 mm Footprint [TQFP]

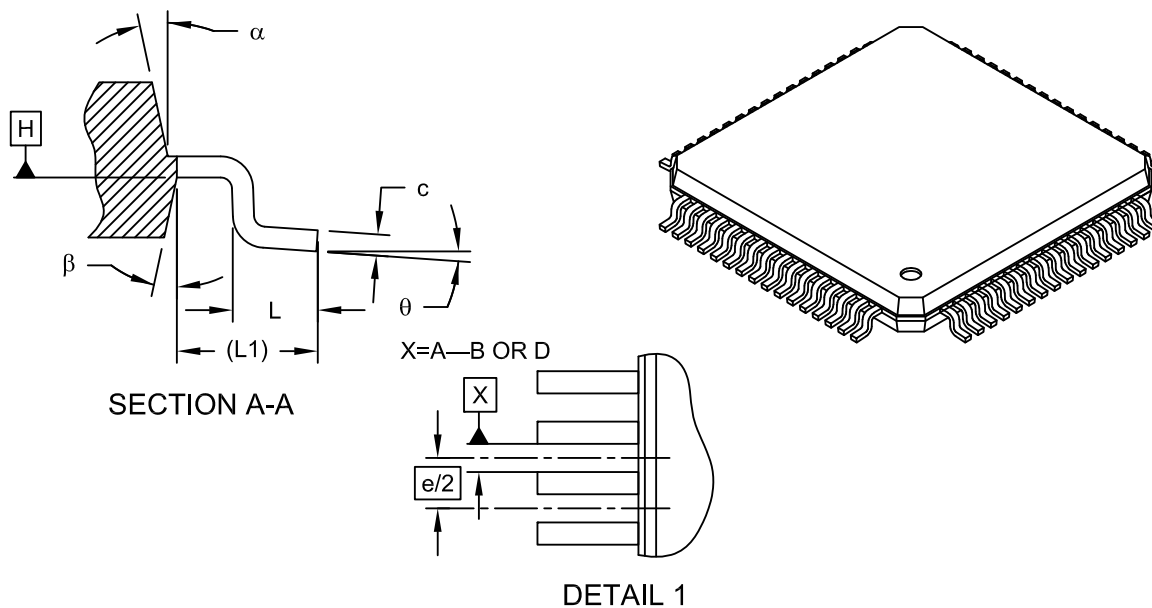
**Note:** For the most current package drawings, please see the Microchip Packaging Specification located at <http://www.microchip.com/packaging>



Microchip Technology Drawing C04-085-V2X Rev E Sheet 1 of 2

## 64-Lead Plastic Thin Quad Flatpack (V2X)-10x10x1 mm Body, 2.00 mm Footprint [TQFP]

**Note:** For the most current package drawings, please see the Microchip Packaging Specification located at <http://www.microchip.com/packaging>



Dimension	Units	MILLIMETERS		
		MIN	NOM	MAX
Number of Leads	N	64		
Lead Pitch	e	0.50 BSC		
Overall Height	A	-	-	1.20
Molded Package Thickness	A2	0.95	1.00	1.05
Standoff	A1	0.05	-	0.15
Foot Length	L	0.45	0.60	0.75
Footprint	L1	1.00 REF		
Foot Angle	$\theta$	0°	3.5°	7°
Overall Width	E	12.00 BSC		
Overall Length	D	12.00 BSC		
Molded Package Width	E1	10.00 BSC		
Molded Package Length	D1	10.00 BSC		
Lead Thickness	c	0.09	-	0.20
Lead Width	b	0.17	0.22	0.27
Mold Draft Angle Top	$\alpha$	11°	12°	13°
Mold Draft Angle Bottom	$\beta$	11°	12°	13°

**Notes:**

- Pin 1 visual index feature may vary, but must be located within the hatched area.
- Chamfers at corners are optional; size may vary.
- Dimensions D1 and E1 do not include mold flash or protrusions. Mold flash or protrusions shall not exceed 0.25mm per side.
- Dimensioning and tolerancing per ASME Y14.5M

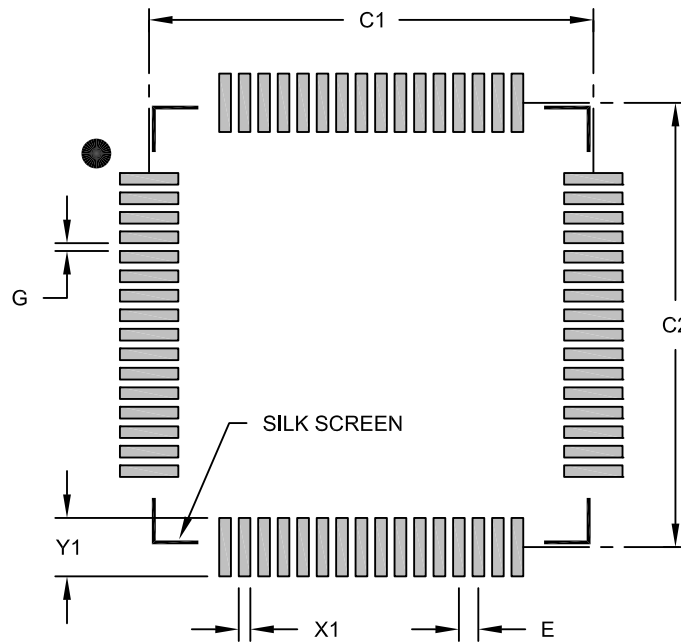
BSC: Basic Dimension. Theoretically exact value shown without tolerances.

REF: Reference Dimension, usually without tolerance, for information purposes only.

Microchip Technology Drawing C04-085-V2X Rev E Sheet 2 of 2



**64-Lead Plastic Thin Quad Flatpack (V2X) 10x10x1 mm Body, 2.00 mm Footprint [TQFP]**



RECOMMENDED LAND PATTERN

Dimension Limits	Units	MILLIMETERS		
		MIN	NOM	MAX
Contact Pitch	E	0.50 BSC		
Contact Pad Spacing	C1		11.40	
Contact Pad Spacing	C2		11.40	
Contact Pad Width (X64)	X1			0.30
Contact Pad Length (X64)	Y1			1.50
Distance Between Pads	G	0.20		

Notes:

1. Dimensioning and tolerancing per ASME Y14.5M

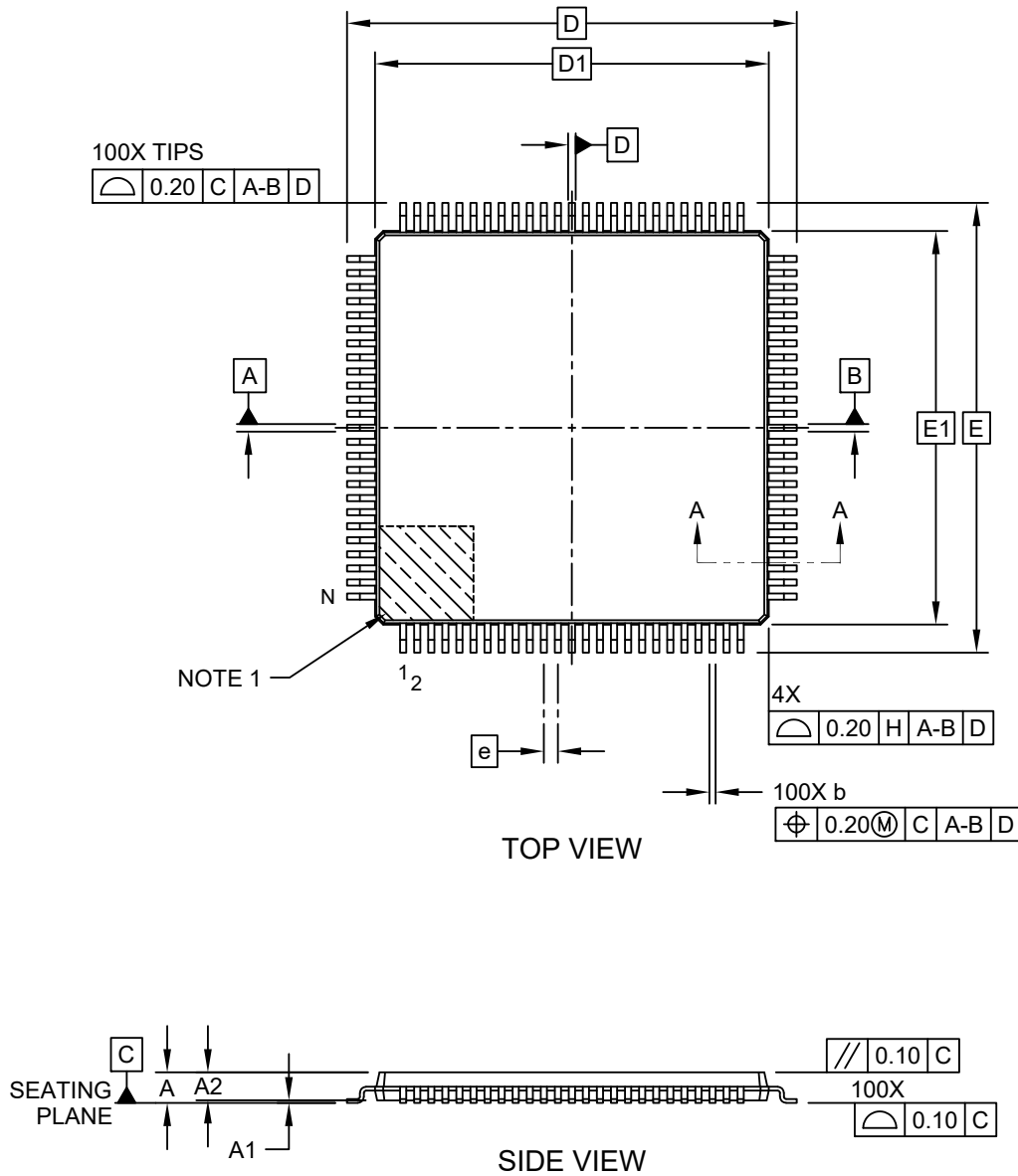
BSC: Basic Dimension. Theoretically exact value shown without tolerances.

Microchip Technology Eraving C04-2085-V2X Rev E

57.2.2 100-pin TQFP

100-Lead Plastic Thin Quad Flatpack (E5X) - 14x14x1 mm Body [TQFP]  
2.00 mm Footprint

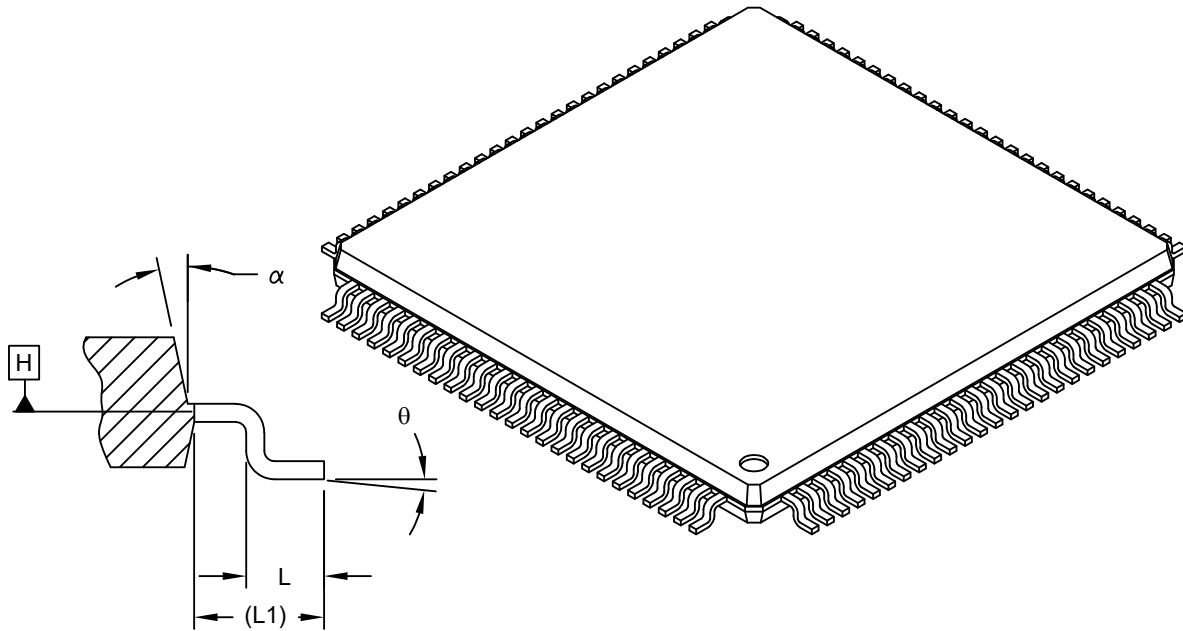
**Note:** For the most current package drawings, please see the Microchip Packaging Specification located at <http://www.microchip.com/packaging>



Microchip Technology Drawing C04-110-E5X Rev C Sheet 1 of 2

## 100-Lead Plastic Thin Quad Flatpack (E5X) - 14x14x1 mm Body [TQFP] 2.00 mm Footprint

**Note:** For the most current package drawings, please see the Microchip Packaging Specification located at <http://www.microchip.com/packaging>



SECTION A-A

Dimension Limits	Units	MILLIMETERS		
		MIN	NOM	MAX
Number of Leads	N	100		
Lead Pitch	e	0.50 BSC		
Overall Height	A	-	-	1.20
Standoff	A1	0.05	-	0.15
Molded Package Thickness	A2	0.95	1.00	1.05
Foot Length	L	0.45	0.60	0.75
Footprint	L1	1.00 REF		
Foot Angle	$\theta$	0°	-	7°
Overall Width	E	16.00 BSC		
Overall Length	D	16.00 BSC		
Molded Package Width	E1	14.00 BSC		
Molded Package Length	D1	14.00 BSC		
Lead Width	b	0.17	0.22	0.27
Mold Draft Angle Top	$\alpha$	11°	-	13°

**Notes:**

1. Pin 1 visual index feature may vary, but must be located within the hatched area.
2. Dimensioning and tolerancing per ASME Y14.5M

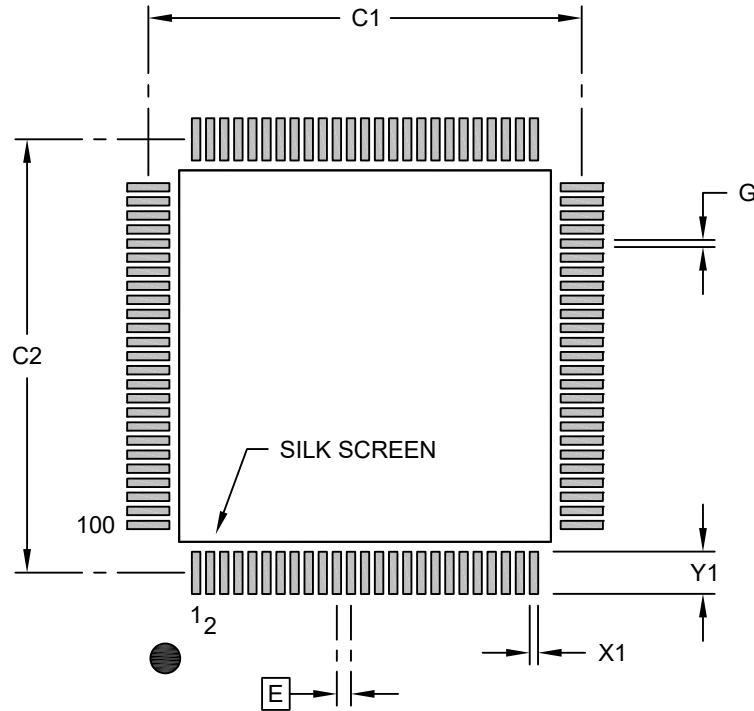
BSC: Basic Dimension. Theoretically exact value shown without tolerances.

REF: Reference Dimension, usually without tolerance, for information purposes only.

Microchip Technology Drawing C04-110-E5X Rev C Sheet 2 of 2

## 100-Lead Plastic Thin Quad Flatpack (E5X) - 14x14x1 mm Body [TQFP] 2.00 mm Footprint

**Note:** For the most current package drawings, please see the Microchip Packaging Specification located at <http://www.microchip.com/packaging>



### RECOMMENDED LAND PATTERN

Dimension Limits	Units	MILLIMETERS		
		MIN	NOM	MAX
Contact Pitch	E	0.50 BSC		
Contact Pad Spacing	C1		15.40	
Contact Pad Spacing	C2		15.40	
Contact Pad Width (X100)	X1			0.30
Contact Pad Length (X100)	Y1			1.50
Contact Pad to Contact Pad (X96)	G	0.20		

**Notes:**

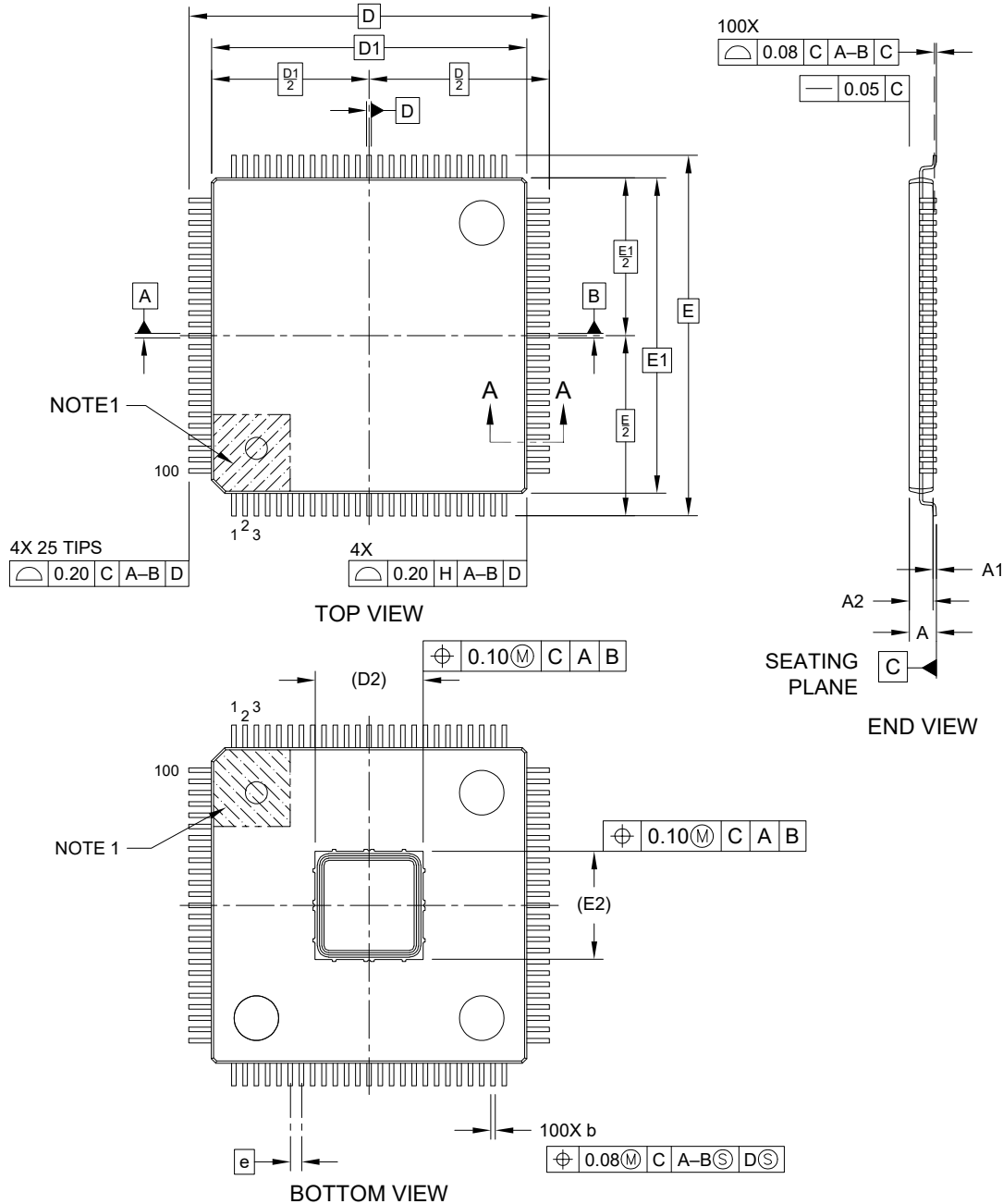
- Dimensioning and tolerancing per ASME Y14.5M  
BSC: Basic Dimension. Theoretically exact value shown without tolerances.
- For best soldering results, thermal vias, if used, should be filled or tented to avoid solder loss during reflow process

Microchip Technology Drawing C04-2110-E5X Rev C

### 57.2.3 100-pin TQFP (with exposed pad)

#### 100-Lead Plastic Thin Quad Flat Pack (4NB) - 14x14x1.0 mm Body [TQFP] With 4.80 mm Grooved Exposed Pad

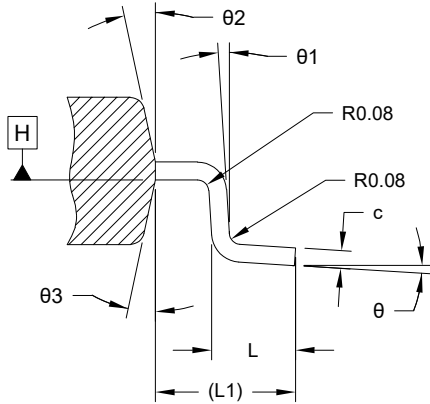
**Note:** For the most current package drawings, please see the Microchip Packaging Specification located at <http://www.microchip.com/packaging>



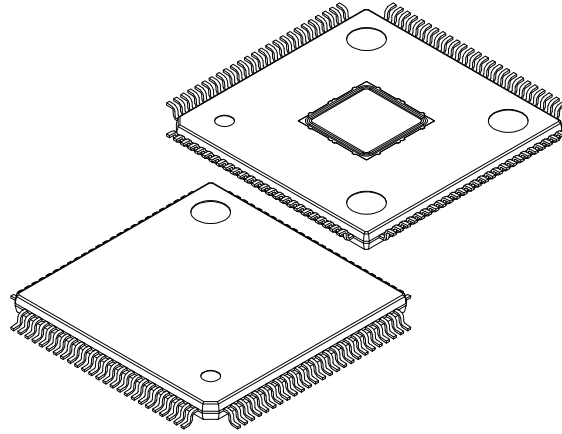
Microchip Technology Drawing C04-21530 Rev A Sheet 1 of 2

**100-Lead Plastic Thin Quad Flat Pack (4NB) - 14x14x1.0 mm Body [TQFP]  
With 4.80 mm Grooved Exposed Pad**

**Note:** For the most current package drawings, please see the Microchip Packaging Specification located at <http://www.microchip.com/packaging>



**SECTION A-A**



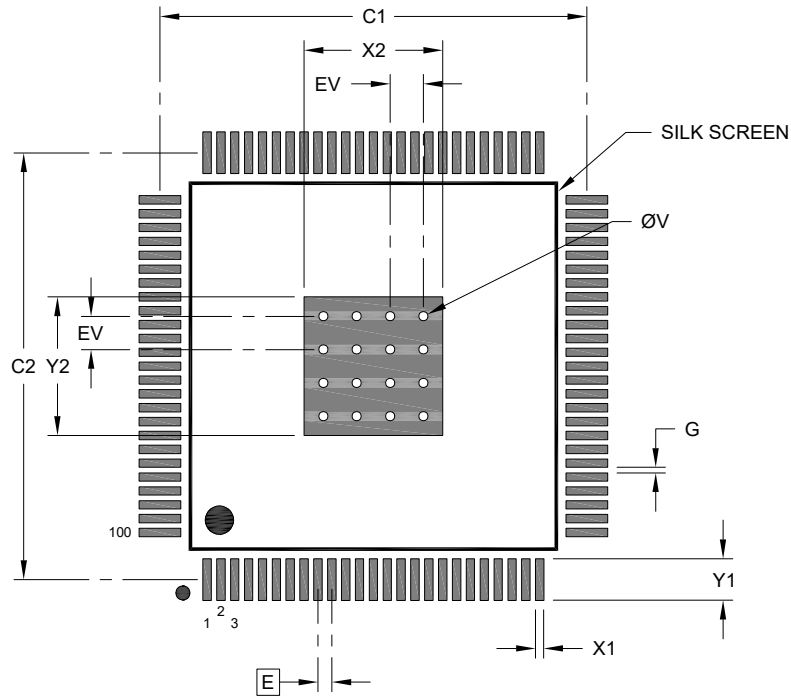
Dimension Limits	Units	MILLIMETERS		
		MIN	NOM	MAX
Number of Terminals	N	100		
Pitch	e	0.50 BSC		
Overall Height	A	-	-	1.20
Standoff	A1	0.05	-	0.15
Molded Package Thickness	A2	0.95	1.00	1.05
Overall Length	D	16.00 BSC		
Molded Package Length	D1	14.00 BSC		
Exposed Pad Length	D2	4.80 REF		
Overall Width	E	16.00 BSC		
Molded Package Width	E1	14.00 BSC		
Exposed Pad Width	E2	4.80 REF		
Terminal Width	b	0.17	0.20	0.27
Terminal Thickness	c	0.09	-	0.20
Terminal Length	L	0.45	0.60	0.75
Footprint	L1	1.00 REF		
Lead Bend Radius	R1	0.08	-	-
Lead Bend Radius	R2	0.08	-	0.20
Foot Angle	θ	0°	3.5°	7°
Lead Angle	θ1	0°	-	-
Mold Draft Angle	θ2	11°	12°	13°
Mold Draft Angle	θ3	11°	12°	13°

**Notes:**

- Pin 1 visual index feature may vary, but must be located within the hatched area.
- Dimensioning and tolerancing per ASME Y14.5M  
BSC: Basic Dimension. Theoretically exact value shown without tolerances.  
REF: Reference Dimension, usually without tolerance, for information purposes only.

**100-Lead Plastic Thin Quad Flat Pack (4NB) - 14x14x1.0 mm Body [TQFP]  
With 4.80 mm Grooved Exposed Pad**

**Note:** For the most current package drawings, please see the Microchip Packaging Specification located at <http://www.microchip.com/packaging>



**RECOMMENDED LAND PATTERN**

Dimension Limits	Units	MILLIMETERS		
		MIN	NOM	MAX
Contact Pitch	E	0.50 BSC		
Center Pad Width	X2			5.00
Center Pad Length	Y2			5.00
Contact Pad Spacing	C1		15.40	
Contact Pad Spacing	C2		15.40	
Contact Pad Width (X100)	X1			0.30
Contact Pad Length (X100)	Y1			1.50
Contact Pad to Contact Pad (X96)	G	0.20		
Thermal Via Diameter	V		0.33	
Thermal Via Pitch	EV		1.20	

**Notes:**

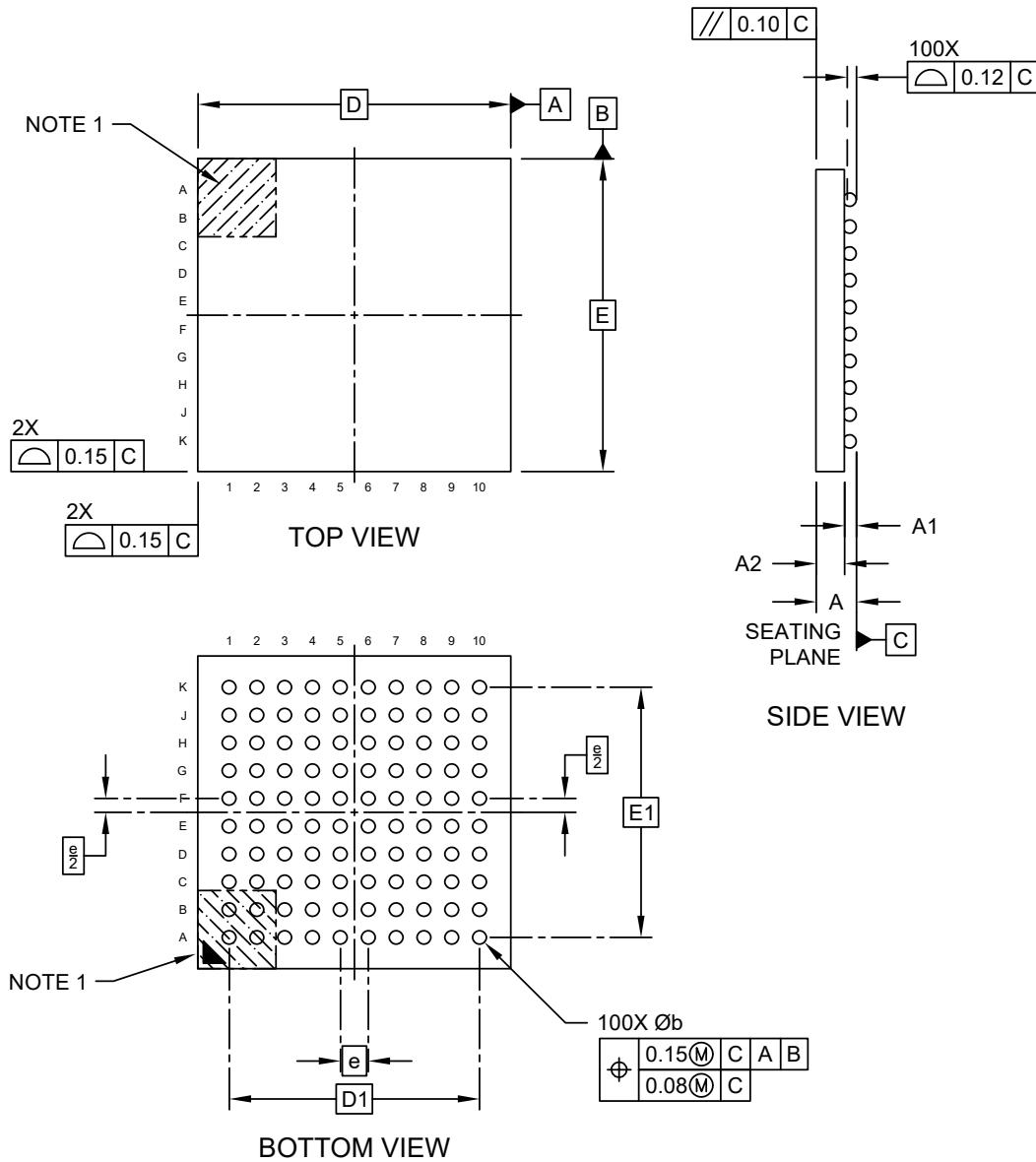
- Dimensioning and tolerancing per ASME Y14.5M  
BSC: Basic Dimension. Theoretically exact value shown without tolerances.
- For best soldering results, thermal vias, if used, should be filled or tented to avoid solder loss during reflow process

Microchip Technology Drawing C04-23530 Rev A

### 57.2.4 100-pin TFBGA

#### 100-Ball Plastic Thin, Fine Pitch Ball Grid Array Package (HJB) - 9x9 mm Body [TFBGA] Atmel Legacy Global Package Code CPR

**Note:** For the most current package drawings, please see the Microchip Packaging Specification located at <http://www.microchip.com/packaging>

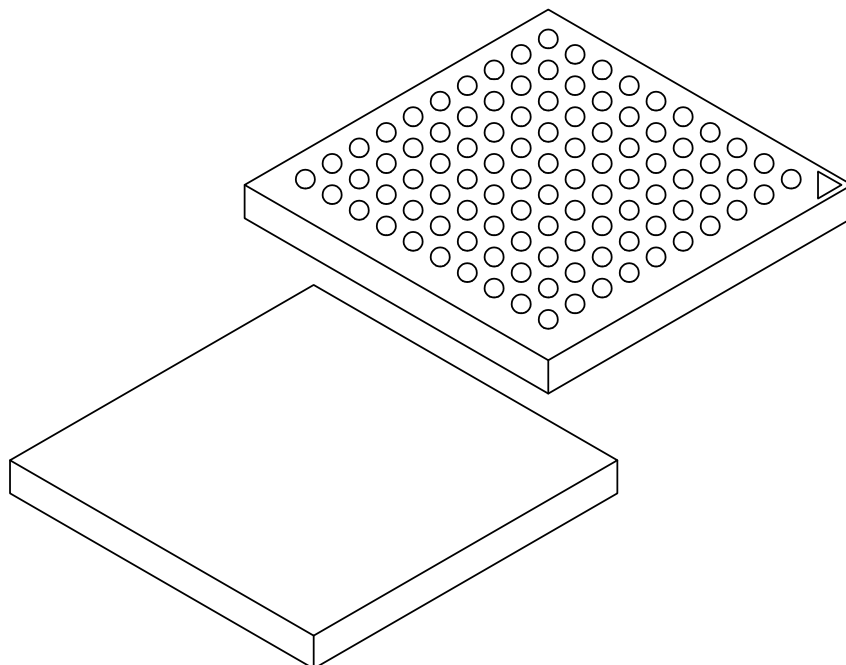


Microchip Technology Drawing C04-21529-HJB Rev B Sheet 1 of 2



**100-Ball Plastic Thin, Fine Pitch Ball Grid Array Package (HJB) - 9x9 mm Body [TFBGA]  
Atmel Legacy Global Package Code CPR**

**Note:** For the most current package drawings, please see the Microchip Packaging Specification located at <http://www.microchip.com/packaging>



Dimension Limits	Units	MILLIMETERS		
		MIN	NOM	MAX
Number of Terminals	N	100		
Pitch	e	0.80 BSC		
Overall Height	A	-	-	1.20
Ball Height	A1	0.25	-	0.40
Molded Package Height	A2	0.65	-	-
Overall Length	D	9.00 BSC		
Overall Pitch	D1	7.20 BSC		
Overall Width	E	9.00 BSC		
Overall Pitch	E1	7.20 BSC		
Terminal Diameter	b	0.35	-	0.50

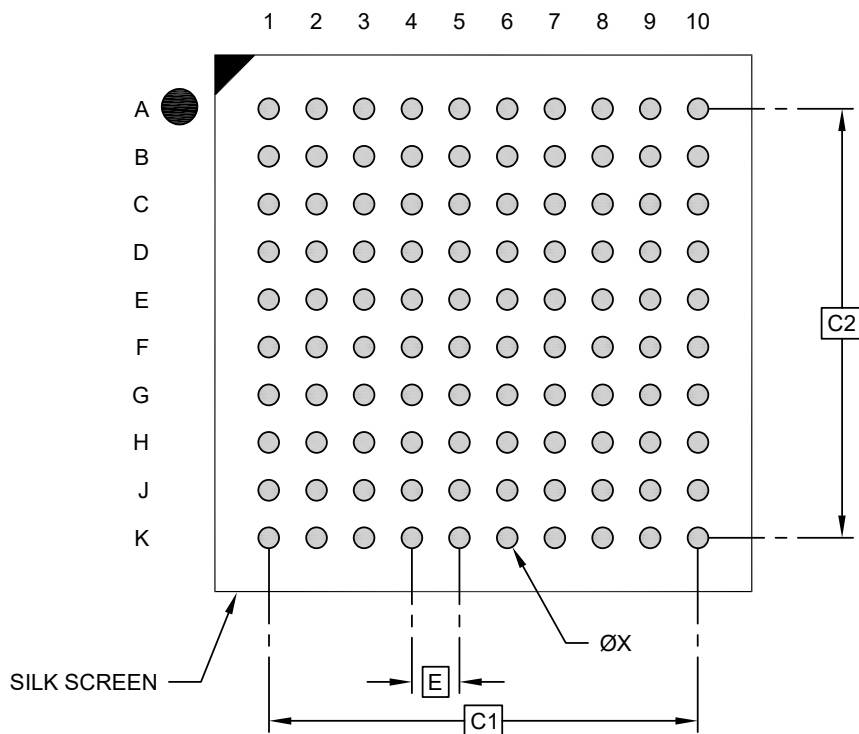
**Notes:**

1. Terminal A1 visual index feature may vary, but must be located within the hatched area.
2. Dimensioning and tolerancing per ASME Y14.5M  
BSC: Basic Dimension. Theoretically exact value shown without tolerances.  
REF: Reference Dimension, usually without tolerance, for information purposes only.
3. Supersedes C04-21111 and C04-21503

Microchip Technology Drawing C04-21529-HJB Rev B Sheet 2 of 2

### 100-Ball Plastic Thin, Fine Pitch Ball Grid Array Package (HJB) - 9x9 mm Body [TFBGA] Atmel Legacy Global Package Code CPR

**Note:** For the most current package drawings, please see the Microchip Packaging Specification located at <http://www.microchip.com/packaging>



#### RECOMMENDED LAND PATTERN

Dimension Limits	Units	MILLIMETERS		
		MIN	NOM	MAX
Contact Pitch	E		0.58 BSC	
Overall Pitch	C1		7.20 BSC	
Contact Pad Spacing	C2		7.20 BSC	
Contact Pad Diameter (X100)	X1			0.35

**Notes:**

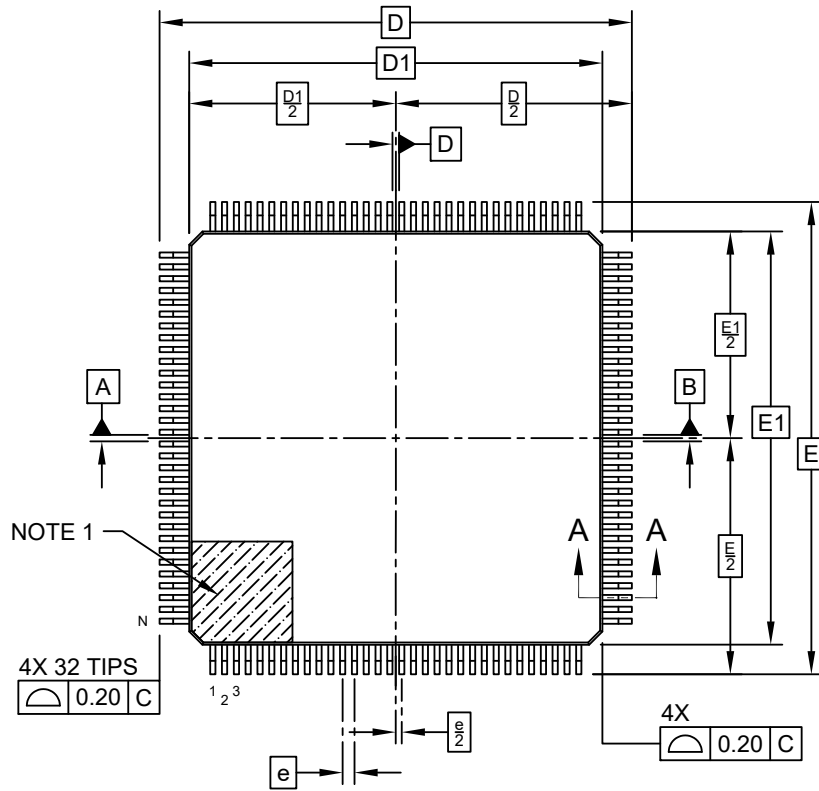
1. Dimensioning and tolerancing per ASME Y14.5M  
BSC: Basic Dimension. Theoretically exact value shown without tolerances.
2. Supersedes C04-23111 and C04-23503

Microchip Technology Drawing C04-23529-HJB Rev B

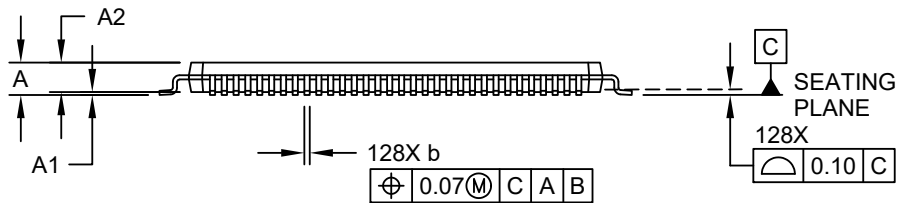
57.2.5 128-pin TQFP

128-Lead Thin Plastic Quad Flatpack (Z2X) - 14x14 mm Body [TQFP]  
SMSC Legacy VTQE3; Atmel Legacy Global Package Code APL

**Note:** For the most current package drawings, please see the Microchip Packaging Specification located at <http://www.microchip.com/packaging>



TOP VIEW

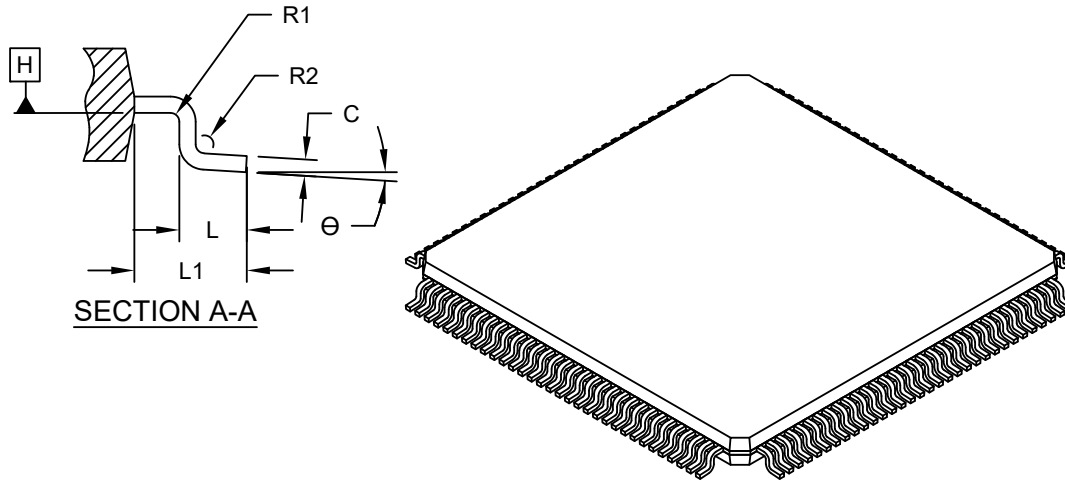


SIDE VIEW

Microchip Technology Drawing C04-181-Z2X Rev D Sheet 1 of 2

**128-Lead Thin Plastic Quad Flatpack (Z2X) - 14x14 mm Body [TQFP]  
SMSC Legacy VTQE3; Atmel Legacy Global Package Code APL**

**Note:** For the most current package drawings, please see the Microchip Packaging Specification located at <http://www.microchip.com/packaging>



		Units	MILLIMETERS		
Dimension Limits			MIN	NOM	MAX
Number of Leads	N		128		
Lead Pitch	e		0.40 BSC		
Overall Height	A	-	-	-	1.20
Standoff	A1	0.05	0.10	-	0.15
Molded Package Thickness	A2	0.95	1.00	-	1.05
Foot Length	L	0.45	0.60	-	0.75
Footprint	L1		1.00 REF		
Foot Angle	$\theta$	0°	-	-	7°
Overall Width	E		16.00 BSC		
Overall Length	D		16.00 BSC		
Molded Package Width	E1		14.00 BSC		
Molded Package Length	D1		14.00 BSC		
Lead Width	b	0.13	0.16	-	0.23
Mold Draft Angle Top	C	0.09	-	-	0.20
Lead Bend Radius	R1	0.08	-	-	-
Lead Bend Radius	R2	0.08	-	-	0.20

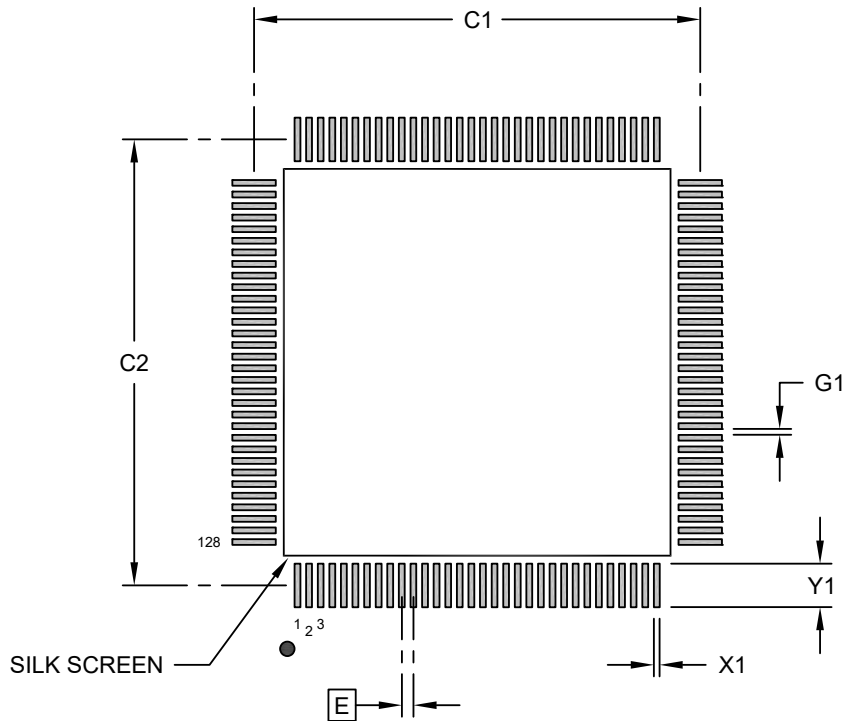
**Notes:**

- Pin 1 visual index feature may vary, but must be located within the hatched area.
- Dimensioning and tolerancing per ASME Y14.5M  
BSC: Basic Dimension. Theoretically exact value shown without tolerances.  
REF: Reference Dimension, usually without tolerance, for information purposes only.

Microchip Technology Drawing C04-181-Z2X Rev D Sheet 2 of 2

**128-Lead Thin Plastic Quad Flatpack (Z2X) - 14x14 mm Body [TQFP]**  
**SMSC Legacy VTQE3; Atmel Legacy Global Package Code APL**

**Note:** For the most current package drawings, please see the Microchip Packaging Specification located at <http://www.microchip.com/packaging>



**RECOMMENDED LAND PATTERN**

Dimension Limits	Units	MILLIMETERS		
		MIN	NOM	MAX
Contact Pitch	E	0.40 BSC		
Contact Pad Spacing	C1		15.40	
Contact Pad Spacing	C2		15.40	
Contact Pad Width (X20)	X1			0.20
Contact Pad Length (X20)	Y1			1.50
Contact Pad to Contact Pad (X124)	G1	0.20		

**Notes:**

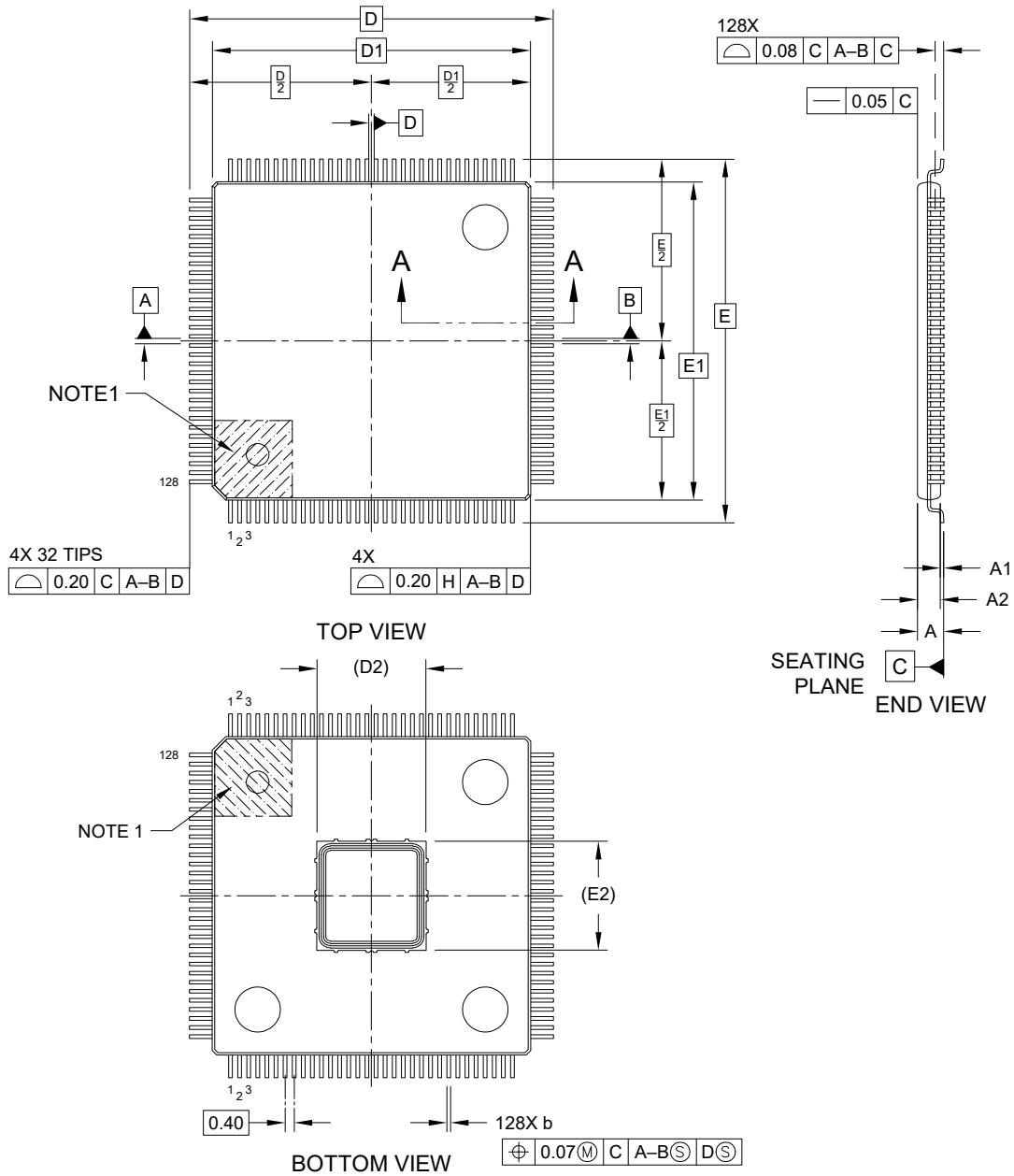
1. Dimensioning and tolerancing per ASME Y14.5M  
BSC: Basic Dimension. Theoretically exact value shown without tolerances.

Microchip Technology Drawing C04-2181-Z2X Rev D

57.2.6 128-pin TQFP (with exposed pad)

128-Lead Plastic Thin Quad Flat Pack (XCB) - 14x14x1.0 mm Body [TQFP]  
With 4.8 mm Grooved Exposed Pad

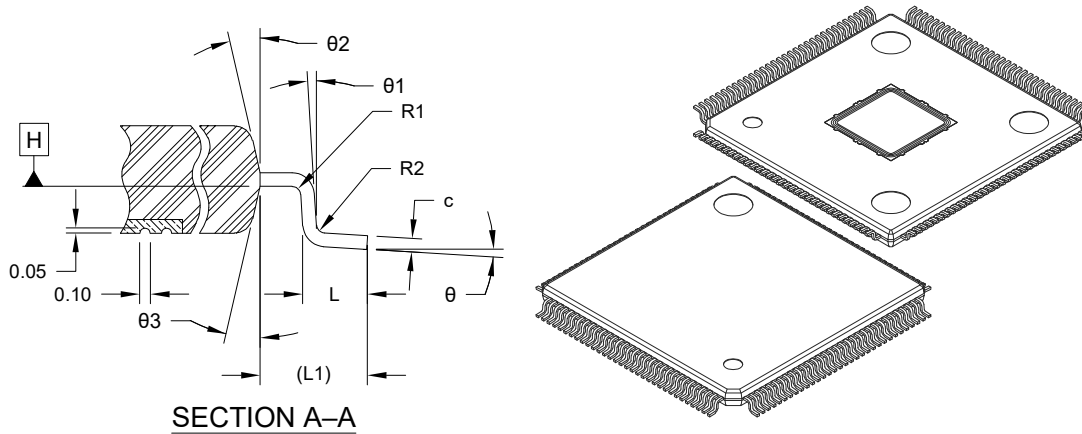
**Note:** For the most current package drawings, please see the Microchip Packaging Specification located at <http://www.microchip.com/packaging>



Microchip Technology Drawing C04-21547 Rev A Sheet 1 of 2

**128-Lead Plastic Thin Quad Flat Pack (XCB) - 14x14x1.0 mm Body [TQFP]  
With 4.8 mm Grooved Exposed Pad**

**Note:** For the most current package drawings, please see the Microchip Packaging Specification located at <http://www.microchip.com/packaging>



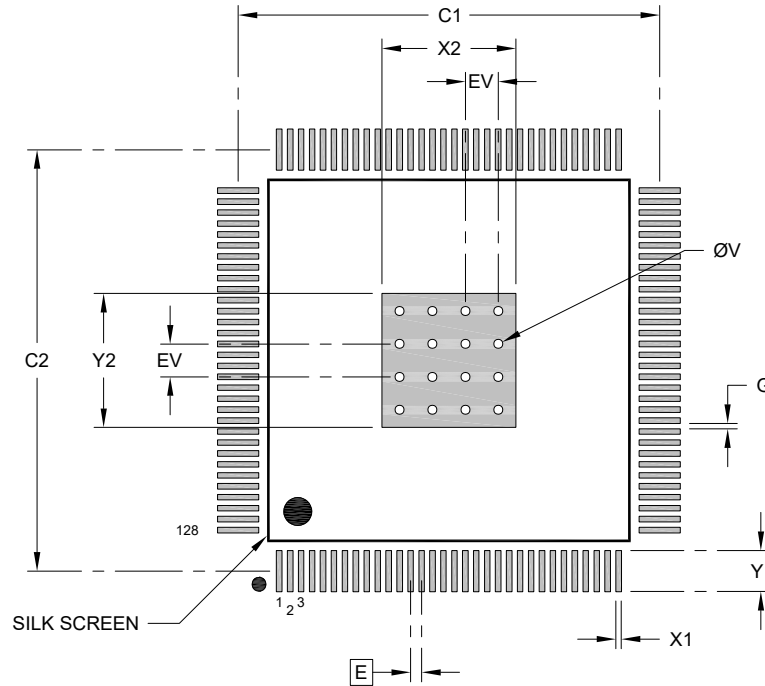
Dimension Limits	Units	MILLIMETERS		
		MIN	NOM	MAX
Number of Terminals	N	128		
Pitch	e	0.40 BSC		
Overall Height	A	-	-	1.20
Standoff	A1	0.05	-	0.15
Molded Package Thickness	A2	0.95	1.00	1.05
Overall Length	D	16.00 BSC		
Molded Package Length	D1	14.00 BSC		
Overall Width	E	16.00 BSC		
Molded Package Width	E1	14.00 BSC		
Exposed Pad Width	D2	4.80 REF		
Exposed Pad Length	E2	4.80 REF		
Terminal Width	b	0.13	0.16	0.23
Terminal Thickness	c	0.09	0.127	0.20
Terminal Length	L	0.45	0.60	0.75
Footprint	L1	1.00 REF		
Lead Bend Radius	R1	0.08	-	-
Lead Bend Radius	R2	0.08	-	0.20
Foot Angle	θ	0°	3.5°	7°
Lead Angle	θ1	0°	-	-
Mold Draft Angle	θ2	11°	12°	13°
Mold Draft Angle	θ3	11°	12°	13°

**Notes:**

- Pin 1 visual index feature may vary, but must be located within the hatched area.
- Dimensioning and tolerancing per ASME Y14.5M  
BSC: Basic Dimension. Theoretically exact value shown without tolerances.  
REF: Reference Dimension, usually without tolerance, for information purposes only.

**128-Lead Plastic Thin Quad Flat Pack (XCB) - 14x14x1.0 mm Body [TQFP]  
With 4.8 mm Grooved Exposed Pad**

**Note:** For the most current package drawings, please see the Microchip Packaging Specification located at <http://www.microchip.com/packaging>



**RECOMMENDED LAND PATTERN**

Dimension Limits	Units	MILLIMETERS		
		MIN	NOM	MAX
Contact Pitch	E	0.40 BSC		
Center Pad Width	X2			4.90
Center Pad Length	Y2			4.90
Contact Pad Spacing	C1		15.40	
Contact Pad Spacing	C2		15.40	
Contact Pad Width (X128)	X1			0.20
Contact Pad Length (X128)	Y1			1.50
Contact Pad to Contact Pad (X124)	G	0.20		
Thermal Via Diameter	V		0.33	
Thermal Via Pitch	EV		1.20	

**Notes:**

1. Dimensioning and tolerancing per ASME Y14.5M  
BSC: Basic Dimension. Theoretically exact value shown without tolerances.
2. For best soldering results, thermal vias, if used, should be filled or tented to avoid solder loss during reflow process

Microchip Technology Drawing C04-23547 Rev A



## 57.3 Soldering Profile

The following table gives the recommended soldering profile from J-STD-20.

**Table 57-1.** Recommended Soldering Profile

Profile Feature	Green Package
Average Ramp-up Rate (217°C to peak)	3°C/s max.
Preheat Temperature 175°C ±25°C	150-200°C
Time Maintained Above 217°C	60-150s
Time within 5°C of Actual Peak Temperature	30s
Peak Temperature Range	260°C
Ramp-down Rate	6°C/s max.
Time 25°C to Peak Temperature	8 minutes max.

A maximum of three reflow passes is allowed per component.

## 58. Schematic Checklist

### 58.1 Introduction

The schematic checklist provides the user with the requirements regarding the different pin connections that must be considered before starting any new board design and information on the minimum hardware resources required to quickly develop an application with the PIC32CX SG41/SG60/SG61 devices. It does not consider PCB layout constraints.

It also provides recommendations regarding low-power design constraints to minimize power consumption.

This information is not intended to be exhaustive. Its objective is to cover as many configurations of use as possible.

Refer to the “Basic 32-Bit MCU Design and Troubleshooting Checklist Guide” on the Microchip web site.



#### **Operation in Noisy Environment**

If the device is operating in an environment with much electromagnetic noise, it must be protected from this noise to ensure reliable operation. In addition to the following best practice EMC design guidelines, the recommendations listed in the schematic checklist sections must be followed. In particular, placing decoupling capacitors very close to the power pins, an RC-filter on the RESET pin, and a pull-up resistor on the SWCLK pin is critical for reliable operations.

It is also relevant to eliminate or attenuate noise in order to avoid that it reaches supply pins, I/O pins, and crystals.

Refer to the “EMI, EMC, EFT, and ESD Circuit Design Consideration for 32-bit Microcontrollers Guide” on the Microchip web site.

---

## 58.2 Power Supply

The PIC32CX SG41/SG60/SG61 supports a single or dual power supply using a battery.

The same voltage must be applied to both VDD and AVDD.

### 58.2.1 Decoupling Capacitors

The use of decoupling capacitors on power supply pins, such as VDD and AVDD, is required.

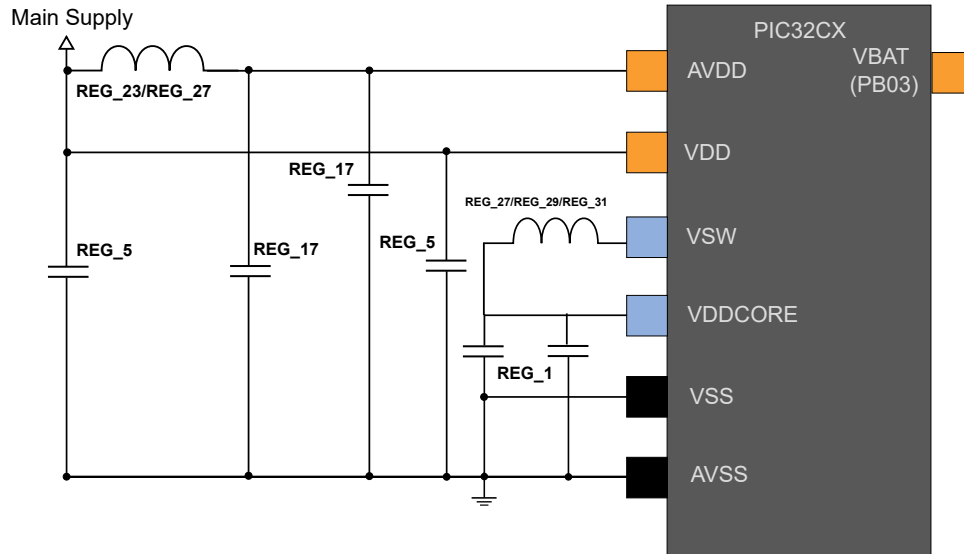
Consider the following criteria when using decoupling capacitors:

- **Bulk capacitors:** Each primary power supply group VDD, AVDD, VDDCORE, and VBAT should have one bulk capacitor. The use of a bulk capacitor is recommended to improve power supply stability. Typical values range from 4.7  $\mu\text{F}$  to 22  $\mu\text{F}$  ceramic or tantalum capacitors with low ESR. This capacitor must be located as close to the device as possible.
- **Value and type of capacitor:** All power pins must have a 100 nF bypass cap. A value of 0.1  $\mu\text{F}$  (100 nF), 10-20V is recommended. The capacitor should be a low Equivalent Series Resistance (low-ESR) capacitor and have resonance frequency in the range of 20 MHz and higher. It is further recommended that ceramic capacitors be used.
- **Placement on the printed circuit board:** The decoupling capacitors should be placed as close to the pins as possible. It is recommended that the capacitors be placed on the same side of the board as the device. If space is constricted, the capacitor can be placed on another layer on the PCB using a via; however, ensure that the trace length from the pin to the capacitor is within one-quarter inch (6 mm) in length.
- **Handling high-frequency noise:** If the board is experiencing high-frequency noise, upward of tens of MHz, add a second ceramic-type capacitor in parallel to the above described decoupling capacitor. The value of the second capacitor can be in the range of 0.01  $\mu\text{F}$  to 0.001  $\mu\text{F}$ . Place this second capacitor next to the primary decoupling capacitor. In high-speed circuit designs, consider implementing a decade pair of capacitances as close to the power and ground pins as possible, for example, 0.1  $\mu\text{F}$  in parallel with 0.001  $\mu\text{F}$ .
- **Maximizing performance:** On the board layout from the power supply circuit, run the power and return traces to the decoupling capacitors first, and then to the device pins. This ensures that the decoupling capacitors are first in the power chain. Equally important is to keep the trace length between the capacitor and the power pins to a minimum thereby reducing PCB track inductance.

### 58.2.2 Power Supply Connections

The following figures shows the recommended power supply connections for switched/linear mode, linear mode only and with battery backup.

**Figure 58-1.** Power Supply Connection for Switching/Linear Mode



**Figure 58-2.** Power Supply Connection for Linear Mode Only

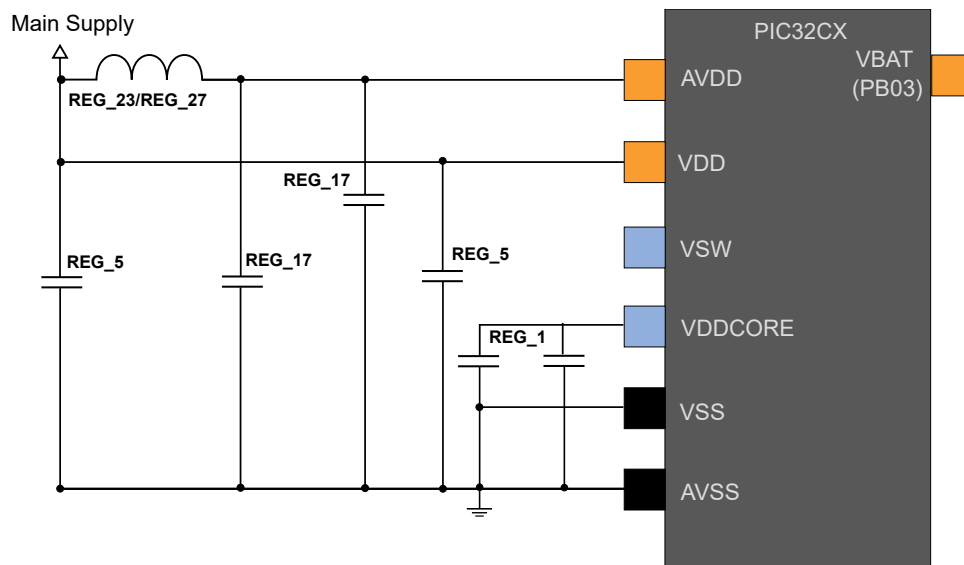
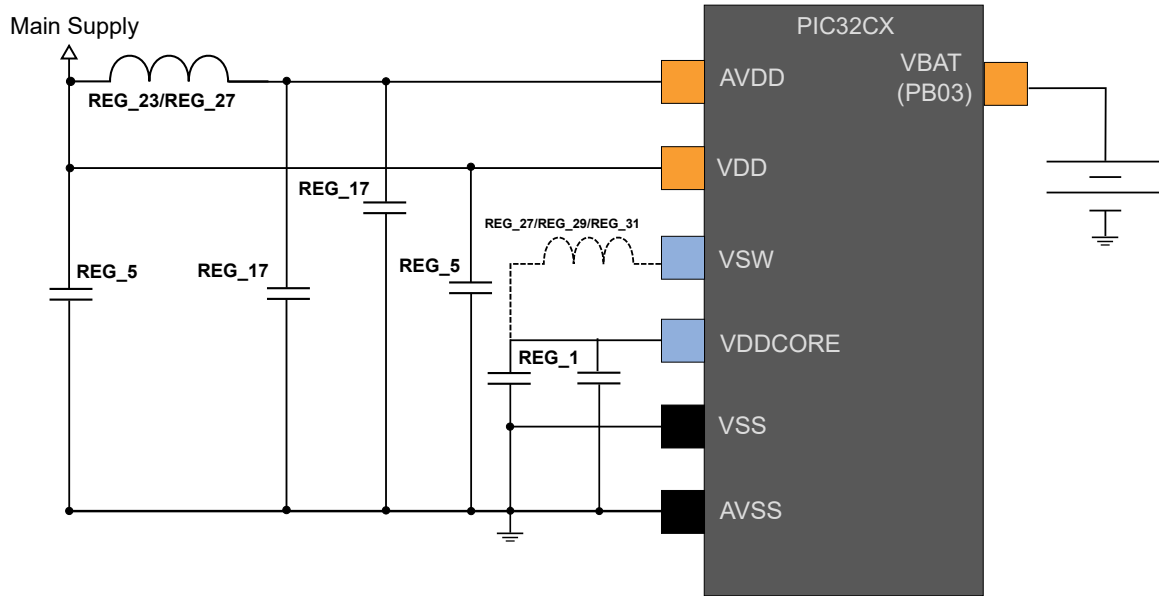


Figure 58-3. Power Supply Connection for Battery Backup Mode



**Table 58-1.** Power Supply Connections <sup>(1,2)</sup>

Signal Name	Associated Ground	Recommended Pin Connection
VDD	VSS	Capacitors: refer to REG_5
AVDD	AVSS	Capacitors: refer to REG_17 Ferrite Bead <sup>(3)</sup> : Refer to REG_23/REG_25
VDDCORE	VSS	Capacitors: refer to REG_1
VSW	-	BUCK mode: Inductor required to VDDCORE: refer to REG_27/REG_29/REG_31 LDO mode: Not Connected
VBAT (PB03)	VSS	Capacitors: refer to REG_13

**Notes:**

1. REG\_X values: refer to [Power Supply Electrical Specifications](#) from the Electrical Characteristics chapter.
2. Decoupling capacitors must be placed close to the device, low ESR capacitors must be used for better decoupling.
3. A ferrite bead must be added between the main power supply (VDD) and AVDD to attenuate high-frequency digital noise from entering the analog power domain. The bead must provide enough impedance to help isolate digital and analog power domains. Make sure to select a ferrite bead with a low DC resistance to avoid any relevant IR drop across the ferrite bead that could impact analog peripherals performance.

**58.2.3 Special Considerations for Packages with an Exposed Pad**

TQFP packages have an exposed pad that must be connected to VSS.

### 58.3 External Analog Reference Connections

The following schematic checklist is only necessary if the application is using many of the external analog references. If the internal references are used instead, the circuits in the following two figures are not necessary.

Figure 58-4. External Analog Reference Schematic With Three References

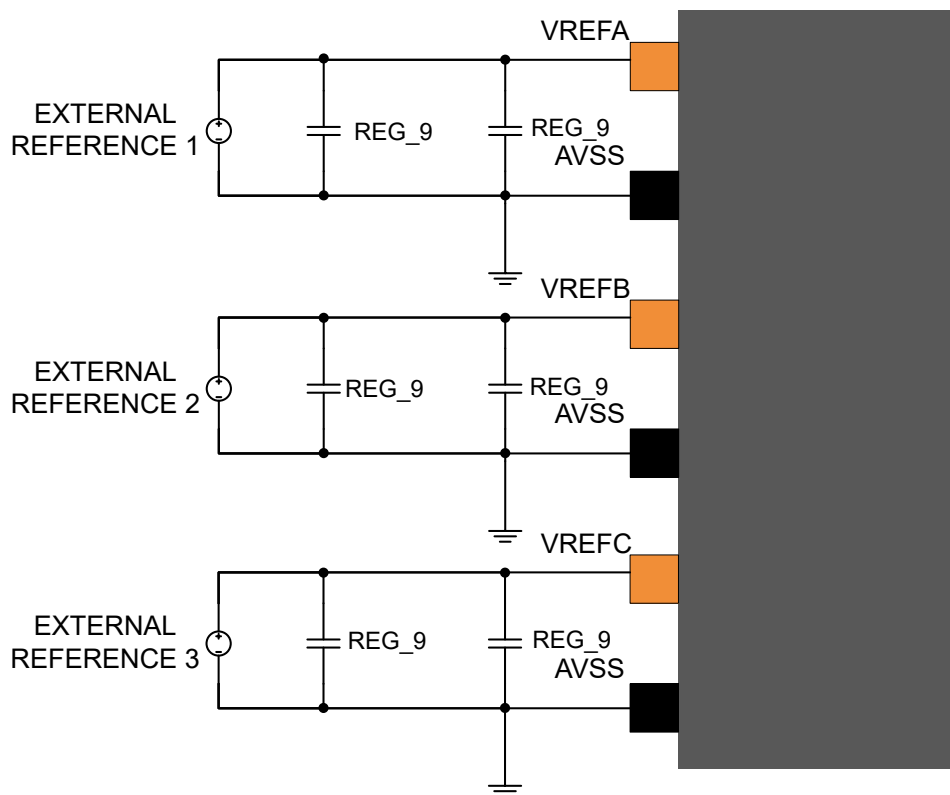


Figure 58-5. External Analog Reference Schematic With Two References

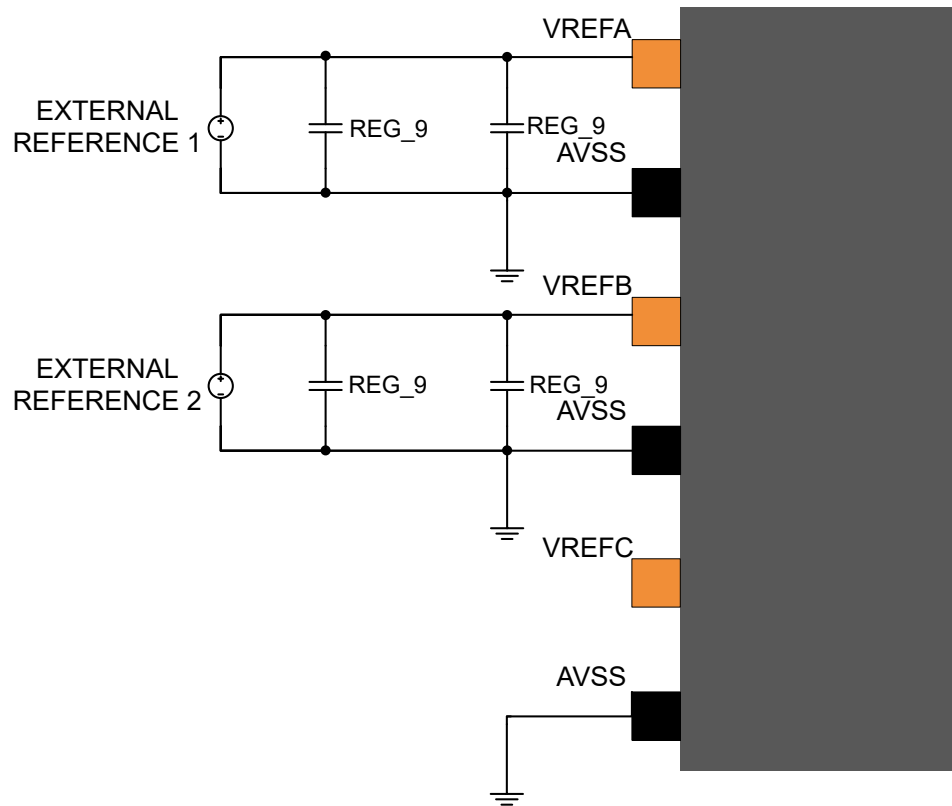




Figure 58-6. External Analog Reference Schematic With One Reference

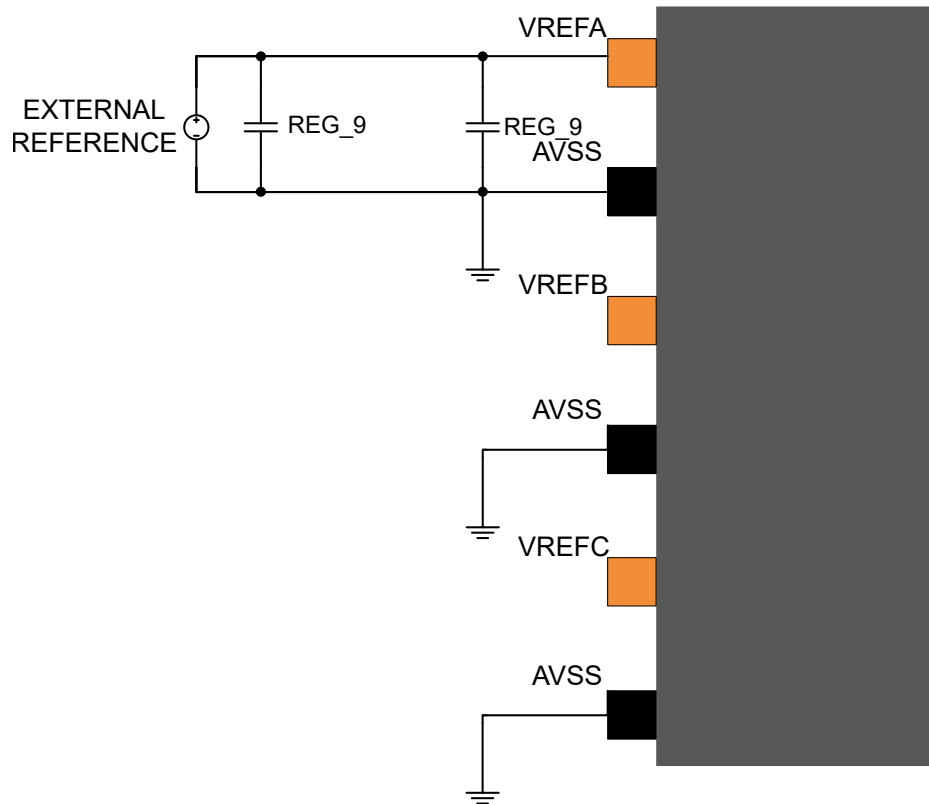


Table 58-2. External Analog Reference Connections

Signal Name	Description	Recommended Pin Connection
VREFx	External reference VREFA/VREFB/VREFC	Capacitors <sup>(2)</sup> : refer to REG_9 <sup>(1)</sup>
AVSS	Ground	-

**Notes:**

1. Refer to the "Power Supply Electrical Specifications" from the *Electrical Characteristics* chapter.
2. Decoupling capacitors must be placed close to the device, low ESR capacitors must be used for better decoupling.

## 58.4 External Reset Circuit

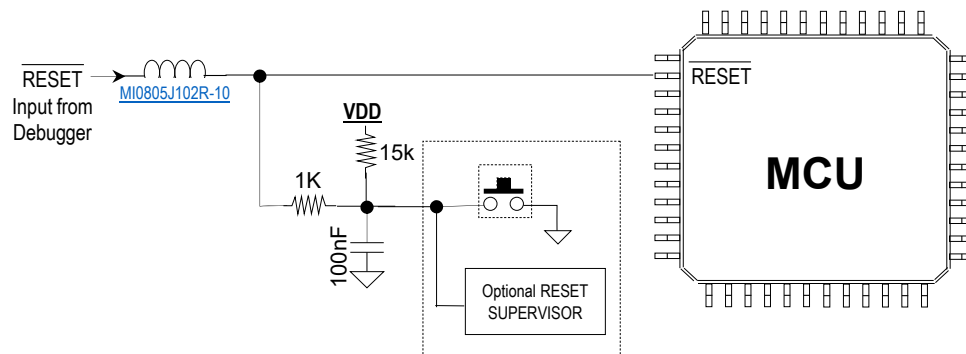
The external Reset circuit is connected to the RESET pin when the external Reset function is used. The circuit is not necessary when the RESET pin is not driven low externally by the application circuitry.

The reset switch can also be removed, if a manual reset is not desired.

A pull-up resistor makes sure that the reset does not go low and unintentionally causing a device reset. An additional resistor has been added in series with the switch to safely discharge the filtering capacitor, that is preventing a current surge when shorting the filtering capacitor which again can cause a noise spike that can have a negative effect on the system.

Place the components illustrated within one-half inch (12 mm) from the RESET pin.

**Figure 58-7.** External Reset Circuit Schematic



**Note:** These values are only given as a typical example. Refer to the [Power Supply Electrical Specifications](#) to determine the proper values given in the system parameters to meet the reset timing requirements ( $T_{RST}$ ).

**Note:** Reset circuit recommendations to improve EFT/ESD/EMI immunity can be found in the “Basic 32-Bit MCU Design and Troubleshooting Checklist Guide” on the Microchip web site.

## 58.5 Unused or Unconnected Pins

Unused I/O pins should not be allowed to float as inputs. It is recommended that unused inputs be ganged together and connecting through a 1k resistor to digital ground or individually or in multiple groups through 1k as the PCB layout permits. This minimizes the chip vulnerability to ESD and radiated EMI due to a high voltage discharge event.

## 58.6 Clocks and Crystal Oscillators

The oscillator circuit should be placed on the same side of the board as the device. Also, place the oscillator circuit close to the respective oscillator pins, not exceeding one-half inch (12 mm) distance between them. The load capacitors should be placed next to the oscillator itself, on the same side of the board. Use a grounded copper pour around the oscillator circuit to isolate them from surrounding circuits. The grounded copper pour should be routed directly to the MCU ground. Do not run any signal traces or power traces inside the ground pour. Also, if using a two-sided board, avoid any traces on the other side of the board where the crystal is placed.



**Important:** Crystal selection must be done using both the crystal data sheet and the crystal oscillator parameters given in both the [XOSC Electrical Specifications](#) and [XOSC32K Electrical Specifications](#) from the [Electrical Characteristics](#) chapter.

### 58.6.1 External Clock Source

Figure 58-8. External Clock Source Schematic

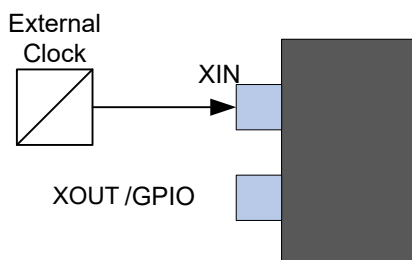
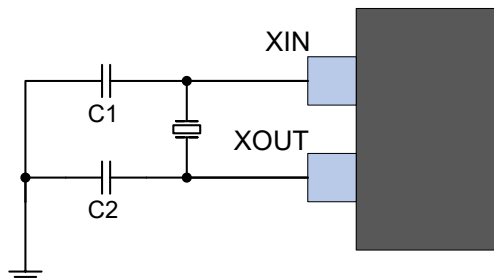


Table 58-3. External Clock Source Connections

Signal Name	Recommended Pin Connection	Description
XIN	XIN is used as input for an external clock signal	Input for inverting oscillator pin External Clock frequency range specified in the XOSC Electrical Specifications (XOSC_35 parameter)
XOUT/GPIO	Can be left unconnected or used as normal GPIO	NC/GPIO

### 58.6.2 Crystal Oscillator

Figure 58-9. Crystal Oscillator Schematic

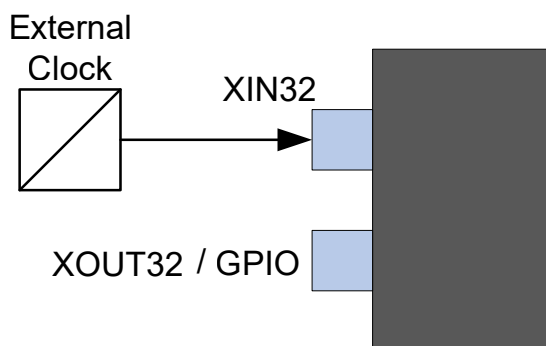


**Table 58-4.** Crystal Oscillator Checklist

Signal Name	Recommended Pin Connection	Description
XIN	C1 Load Capacitor	Crystal frequency range specified in the XOSC Electrical Specifications (XOSC_1 parameter)
XOUT	C2 Load Capacitor	

### 58.6.3 External Slow Clock Source

**Figure 58-10.** External Clock Source Connections

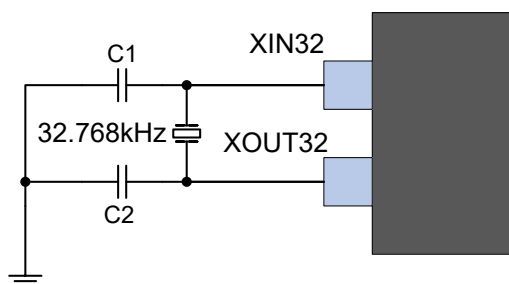


**Table 58-5.** External Slow Clock Source Connections

Signal Name	Recommended Pin Connection	Description
XIN32	XIN32 is used as input for an external clock signal	Input for inverting the oscillator pin External Clock frequency range specified in the XOSC32 Electrical Specifications (XOSC32_19 parameter).
XOUT32	Can be left unconnected or used as normal GPIO	NC/GPIO

### 58.6.4 32.768 kHz Crystal Oscillator

**Figure 58-11.** 32.768 kHz Crystal Oscillator Schematics



**Table 58-6.** 32.768 kHz Crystal Oscillator Checklist

Signal Name	Recommended Pin Connection	Description
XIN32	C1 Load Capacitor	Crystal frequency range specified in the XOSC32K Electrical Characteristics (XOSC32_1 parameter)
XOUT32	C2 Load Capacitor	

**Note:** In order to minimize the cycle-to-cycle jitter of the external oscillator, keep the neighboring pins as steady as possible. For neighboring pin details, refer to the [Oscillator Pinout](#) section.

## 58.7 Programming and Debugging

For programming and debugging PIC32CX SG41/SG60/SG61, the device must be connected using the Serial Wire Debug (SWD) interface. Currently the SWD interface is supported by several Microchip and third party programmers and debuggers.

The PIC32CX SG41/SG60/SG61 Curiosity Ultra evaluation board supports programming and debugging through the on-board embedded debugger, hence external programmer or debugger is not required.

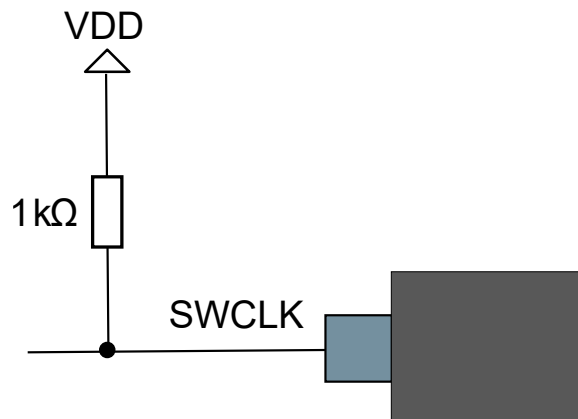
Refer to the related Microchip User Guides for information on debugging and programming connections and options. For connecting to any other programming or debugging tool, refer to that specific programmer or debugger's user guide.

### 58.7.1 Debugging and Programming Pins

The SWDIO, SWO, SWCLK pins are used for In-Circuit programming and debugging purposes. It is recommended to keep the trace length between the debug external connector and the debug pins on the device as short as possible to minimize ESD/EMI vulnerabilities. If the debug external connector is expected to experience an ESD event, a series resistor is recommended, with the value in the range of a few tens of Ohms, not to exceed 100 Ohms with protection using Transient Voltage Suppressors (TVS), at the user's discretion. See image below for more information.



**Important:** The SWCLK pin is by default internally pulled-up after reset, but a pull-up resistor on the SWCLK pin is critical for reliable operations.



**Note:** JTAG and Serial Wire Interface recommendations can be found in the “Basic 32-Bit MCU Design and Troubleshooting Checklist Guide” on the Microchip web site.

## 58.8 Designing for High-Speed Peripherals

The PIC32C family of devices have peripherals that operate at frequencies much higher than the typical for an embedded environment. The following table lists the peripherals that produce high-speed signals on their external pins:

**Table 58-7.** Peripherals that Produce High-Speed Signals on External Pins

Peripheral
SPI (Sercom)
QSPI (Quad SPI)
Ethernet GMAC

Due to these high-speed peripheral signals, it is important to consider several factors when designing a product that uses these peripherals, and the PCB on which these components will be placed. Adhering to these recommendations will help achieve the following goals:

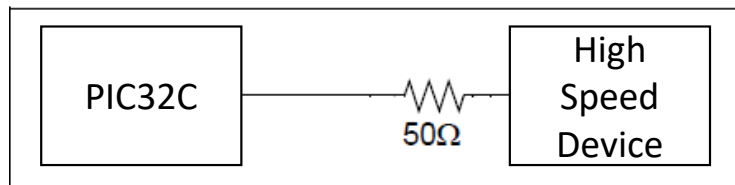
- Minimize the effects of electromagnetic interference for the proper operation of the product.
- Run all PCB high-speed signals first on component side of PCB.
- Ensure signals arrive at their intended destination at the same time by matching critical trace lengths on the PCB.
- Minimize crosstalk. Insure continuous ground under all high-speed signals.
- Maintain signal integrity by the use of termination resistors in the 30-50 ohm range.
- Reduce system noise by using bulk and high frequency decoupling caps and inductors on power rails.
- Minimize ground bounce and power sag. Use a dedicated ground plane if possible or at a minimum a star ground configuration. Do not daisy chain ground and power traces to components.

### 58.8.1 System Design

#### 58.8.1.1 Impedance Matching

When selecting parts to place on high-speed signal bus, if the remote I/O pin impedance of the peripheral device does not match the impedance of the pins on the PIC32C device to which it is connected, signal reflections could result, thereby degrading the quality of the signal. If it is not possible to select a product that matches impedance, place a series resistor at the load to create the matching impedance. See the following figure for an example.

**Figure 58-12.** Series Resistor



#### 58.8.1.2 PCB Layout Recommendations

The following recommendations will help ensure the PCB layout will promote the goals previously listed.

- **Component Placement:**
  - Place bypass capacitors as close to their component power and ground pins as possible, and place them on the same side of the PCB.

- Devices on the same bus that have larger setup times must be placed closer to the PIC32C family of devices.
- **Power and Ground:**
  - Multi-layer PCBs will allow separate power and ground planes
  - Each ground pin should be connected to the ground plane individually
  - Place bypass capacitor vias as close to the pad as possible (preferably inside the pad)
  - If power and ground planes are not used, maximize width for power and ground traces
  - Use low-ESR, surface-mount bypass capacitors
- **Clocks and Oscillators:**
  - Place crystals as close as possible to the PIC32C device XIN/XOUT pins
  - Do not route high-speed signals near the clock or oscillator
  - Avoid via usage and branches in high speed clock lines
  - Place termination resistors at the end of clock lines
- **Traces:**
  - Higher-priority signals must have the shortest traces
  - Avoid long run lengths on parallel traces to reduce coupling
  - Make the clock traces as straight as possible
  - Use rounded turns rather than right-angle turns
  - Have traces on different layers intersect on right angles to minimize crosstalk
  - Maximize the distance between traces, preferably no less than three times the trace width
  - Power traces should be as short and as wide as possible
  - High-speed traces must have a continuous ground beneath them

#### 58.8.1.3 EMI/EMC/EFT (IEC 61000-4-4 and IEC 61000-4-2) Supression Considerations

The use of LDO regulators is preferred to reduce overall system noise and provide a cleaner power source. However, when utilizing switching Buck/Boost regulators as the local power source for PIC32C devices, as well as in electrically noisy environments or test conditions required for IEC 61000-4-4 and IEC 61000-4-2, users should evaluate the use of Pie-Filters (i.e., L-C) on the power pins, as shown in the [Schematic Checklist](#) chapter. In addition to a less noisy power source, use of this type of T-Filter can greatly reduce susceptibility to EMI sources and events. Use Transient Voltage Suppressors (TVS) on power buses as well as on all external PCB signal connections. If design requirements mandate the use of a buck or boost regulator be sure inductor used is shielded type.

## 58.9 QSPI Interface

Signal integrity can be improved by adding series resistors on each QSPI line. The resistor value should be based on the corresponding I/O pin drive strength (decided by PINCFGn.DRVSTR) and PCB trace impedance. It is recommended to do simulation using the device IBIS files to choose the correct termination and PCB trace impedance combination.

## 58.10 USB Interface

The USB interface consists of a differential data pair (D+/D-).

Refer to the *Electrical Characteristics* section for operating voltages which will allow USB operation.

**Table 58-8.** USB Interface Checklist

Signal Name	Recommended Pin Connection	Description
D+	<ul style="list-style-type: none"> <li>The impedance of the pair must be matched on the PCB to minimize reflections.</li> <li>USB differential tracks must be routed with the same characteristics (length, width, number of vias, and so on).</li> </ul>	USB full-speed/low-speed positive data upstream pin.
D-	<ul style="list-style-type: none"> <li>For a tightly coupled differential pair, the signal routing must be as parallel as possible with a minimum number of angles and vias.</li> </ul>	USB full-speed/low-speed negative data upstream pin.

USB Host and Device Interface recommendations can be found in the *Basic 32-Bit MCU Design and Troubleshooting Checklist* guide on the Microchip web site.



## 59. Conventions

### 59.1 Numerical Notation

**Table 59-1.** Numerical Notation

Symbol	Description
165	Decimal number
0b0101	Binary number
'0101'	Binary numbers are given without prefix if unambiguous
0x3B24	Hexadecimal number
X	Represents an unknown or do not care value
Z	Represents a high-impedance (floating) state for either a signal or a bus

### 59.2 Memory Size and Type

**Table 59-2.** Memory Size and Bit Rate

Symbol	Description
KB (kbyte)	kilobyte ( $2^{10} = 1024$ )
MB (Mbyte)	megabyte ( $2^{20} = 1024*1024$ )
GB (Gbyte)	gigabyte ( $2^{30} = 1024*1024*1024$ )
b	bit (binary '0' or '1')
B	byte (8 bits)
1kbit/s	1,000 bit/s rate (not 1,024 bit/s)
1Mbit/s	1,000,000 bit/s rate
1Gbit/s	1,000,000,000 bit/s rate
word	32 bit
half-word	16 bit

### 59.3 Frequency and Time

**Table 59-3.** Frequency and Time

Symbol	Description
kHz	1 kHz = $10^3$ Hz = 1,000 Hz
MHz	1 MHz = $10^6$ Hz = 1,000,000 Hz
GHz	1 GHz = $10^9$ Hz = 1,000,000,000 Hz
ms	1 ms = $10^{-3}$ s = 0.001s
μs	1 μs = $10^{-6}$ s = 0.000001s
ns	1 ns = $10^{-9}$ s = 0.000000001s

### 59.4 Registers and Bits

**Table 59-4.** Register and Bit Mnemonics

Symbol	Description
R/W	Read/Write accessible register bit. The user can read from and write to this bit.
R	Read-only accessible register bit. The user can only read this bit. Writes will be ignored.
W	Write-only accessible register bit. The user can only write this bit. Reading this bit will return an undefined value.
BIT	Bit names are shown in uppercase. (Example ENABLE)

## .....continued

Symbol	Description
FIELD[n:m]	A set of bits from bit n down to m. (Example: PINA[3:0] = {PINA3, PINA2, PINA1, PINA0})
Reserved	Reserved bits are unused and reserved for future use. For compatibility with future devices, always write reserved bits to zero when the register is written. Reserved bits will always return zero when read. Reserved bit field values must not be written to a bit field. A reserved value will not be read from a read-only bit field. Do not write any value to reserved bits of a fuse.
PERIPHERAL <i>i</i>	If several instances of a peripheral exist, the peripheral name is followed by a number to indicate the number of the instance in the range 0-n. PERIPHERAL0 denotes one specific instance.
Reset	Value of a register after a Power-on Reset. This is also the value of registers in a peripheral after performing a software Reset of the peripheral, except for the Debug Control registers.
SET/CLR	Registers with SET/CLR suffix allows the user to clear and set bits in a register without doing a read-modify-write operation. These registers always come in pairs. Writing a '1' to a bit in the CLR register will clear the corresponding bit in both registers, while writing a '1' to a bit in the SET register will set the corresponding bit in both registers. Both registers will return the same value when read. If both registers are written simultaneously, the write to the CLR register will take precedence.

## 60. Acronyms and Abbreviations

The following table contains acronyms and abbreviations used in this document.

**Table 60-1.** Acronyms and Abbreviations

Abbreviation	Description
AC	Analog Comparator
ADC	Analog-to-Digital Converter
ADDR	Address
AES	Advanced Encryption Standard
AHB	Advanced High-performance Bus
AMBA	Advanced Microcontroller Bus Architecture
APB	AMBA Advanced Peripheral Bus
AREF	Analog Reference Voltage
AVDD	Analog Supply Voltage
BOD	Brown-out Detector
CAL	Calibration
CC	Compare/Capture
CCL	Configurable Custom Logic
CLK	Clock
CRC	Cyclic Redundancy Check
CTRL	Control
DAC	Digital-to-Analog Converter
DAP	Debug Access Port
DFLL	Digital Frequency Locked Loop
DPLL	Digital Phase Locked Loop
DMAC	DMA (Direct Memory Access) Controller
DSU	Device Service Unit
EEPROM	Electrically Erasable Programmable Read-Only Memory
EIC	External Interrupt Controller
EVSYS	Event System
FDPLL	Fractional Digital Phase Locked Loop, also DPLL
FREQM	Frequency Meter
GCLK	Generic Clock Controller
GPIO	General Purpose Input/Output
I <sup>2</sup> C	Inter-Integrated Circuit
IF	Interrupt Flag
INT	Interrupt
MBIST	Memory Built-In Self-Test
MEM-AP	Memory Access Port
MIB	Management Information Base
MII	Media Independent Interface
MTB	Micro Trace Buffer
NMI	Non-maskable Interrupt
NVIC	Nested Vector Interrupt Controller
NVM	Nonvolatile Memory
NVMCTRL	Nonvolatile Memory Controller

.....continued

Abbreviation	Description
OPAMP	Operation Amplifier
OSC	Oscillator
PAC	Peripheral Access Controller
PC	Program Counter
PER	Period
PM	Power Manager
POR	Power-on Reset
PORT	I/O Pin Controller
PTC	Peripheral Touch Controller
PWM	Pulse-Width Modulation
RAM	Random-Access Memory
REF	Reference
RMII	Reduced Media Independent Interface
RTC	Real-Time Counter
RX	Receiver/Receive
SEES	SmartEEPROM Sector
SEEP	SmartEEPROM Page
SERCOM	Serial Communication Interface
SLCD	Segmented Liquid Crystal Display
SMBus	System Management Bus
SNAP	Sub-Network Access Protocol
SP	Stack Pointer
SPI	Serial Peripheral Interface
SRAM	Static Random Access Memory
SUPC	Supply Controller
SYSCTRL	System Controller - not implemented in L21, 22 etc
SWD	Serial Wire Debug
TC	Timer/Counter
TRNG	True Random Number Generator
TX	Transmitter/Transmit
ULP	Ultra Low-Power
USART	Universal Synchronous and Asynchronous Serial Receiver and Transmitter
USB	Universal Serial Bus
VDD	Digital Supply Voltage
VREF	Voltage Reference
VSS/AVSS	Ground
WDT	Watchdog Timer
XOSC	Crystal Oscillator

## 61. PIC32CX SG41/SG60/SG61 Revision History

### Revision G - 08/2023

The following updates were performed in this revision:

Section	Description
1-MB Flash, 256-KB SRAM with optional Hardware Security Module, Crypto, 1 MSPS 12-bit ADC, QSPI, USB, Ethernet, and PTC	Updated <a href="#">Table 1</a>
1. Configuration Summary	Updated <a href="#">Table 1-1</a>
2. Ordering Information	Added additional package and count options in <a href="#">Figure 2-1</a>
4. Pinout and Packaging	Added section <a href="#">4.1. 64-pin TQFP</a> Modified PNs in sections <a href="#">4.2. 100-pin TFBGA</a> and <a href="#">100-pin TQFP</a> and <a href="#">4.3. 128-pin TQFP</a> Added info of 64-pin TQFP in <a href="#">Table 4-30</a>
13. Device Service Unit (DSU)	Updated the table for the DEVSEL bitfield in the <a href="#">13.12.8. DID Register</a>
34. SERCOM Inter-Integrated Circuit (SERCOM I2C)	Added info of 64-pin TQFP in <a href="#">Table 34-1</a>
55. Electrical Specifications 85°C	Added info of 64-pin TQFP in <a href="#">Table 55-5</a>
57. Packaging Information	Added <a href="#">Figure 57-1</a> Added section <a href="#">57.2.1. 64-pin TQFP</a>

### Revision F - 05/2023

The following updates were performed in this revision:

Section	Description
1-MB Flash, 256-KB SRAM with optional Hardware Security Module, Crypto, 1 MSPS 12-bit ADC, QSPI, USB, Ethernet, and PTC	<ul style="list-style-type: none"> <li>Added a new section titled: Software and Tools Support: Develop Prototypes Quickly With A Powerful, Easy-to-Use Ecosystem</li> </ul>
NVMCTRL	<ul style="list-style-type: none"> <li>Updated the settings in <a href="#">Security Bit Set Procedure</a></li> <li>Updated the Register reset value for <a href="#">SEESTAT</a></li> <li>Updated <a href="#">27.5.10.1. Security Bit Set Procedure</a>, Replaced Step no. 3.</li> <li>Replace note <a href="#">27.5.18. Immutable Boot, Boot Read Protection, and Secure Debug Features Overview</a>, under the table 27-13.</li> </ul>
CAN	<ul style="list-style-type: none"> <li>Added new verbiage to the <a href="#">NBTP Register</a></li> </ul>
RTC	Updated <a href="#">23.6.8.5.1. Timestamp</a> with a new note, and added Note 3.
CCL	Updated important note in <a href="#">43.6.2.2. Enabling, Disabling, and Resetting</a> , also updated the CTRL register
ADC	A new note has been added <a href="#">51.6.3.4. Host - Client Operation</a>
AC	A note has been added <a href="#">52.6.9. Offset Compensation</a>

.....continued

Section	Description
USB	<ul style="list-style-type: none"> <li>Performed minor editorial updates to <a href="#">FSMSTATUS</a></li> <li>Updated the table for the SPDCONF bitfield and removed obsolete bitfields from the <a href="#">CTRLB</a> Register</li> <li>Removed obsolete bitfield MFNUM from the <a href="#">FNUM</a> Register</li> <li>Removed obsolete bitfield MSOF from the following registers:                             <ul style="list-style-type: none"> <li><a href="#">INTENCLR</a></li> <li><a href="#">INTENSET</a></li> <li><a href="#">INTFLAG</a></li> </ul> </li> <li>Removed obsolete bitfield NYETDIS from the <a href="#">EPCFGn</a> Register</li> <li>Removed the TSTK and TSTJ obsolete bitfields from the <a href="#">CTRLB</a> Register and updated the SPDCONF bitfield table</li> <li>Removed an obsolete table form the FLENCE bitfield in the <a href="#">HSOFC</a> Register</li> <li>Performed minor editorial updates to <a href="#">STATUS</a></li> <li>Removed obsolete bitfield MFNUM from the <a href="#">FNUM</a> Register</li> <li>Updated the table for the FLENHIGH bitfield in the <a href="#">FLENHIGH</a> Register</li> <li>Removed an obsolete table from the BINTERVAL bitfield in the <a href="#">BINTERVALn</a> Register</li> <li>Updated the table for the SIZE bitfield in the <a href="#">PCKSIZE</a> Register</li> </ul>

### Revision E - 02/2023

The following updates were performed in this revision:

Section	Description
Block Diagram	<ul style="list-style-type: none"> <li>Replaced the diagram with a new image</li> </ul>
Processor and Architecture	<ul style="list-style-type: none"> <li>Clarified CMCC in table 10-1 in <a href="#">Configuration</a></li> </ul>
DSU	<ul style="list-style-type: none"> <li>Updated the PROT bitfield in the <a href="#">STATUSB</a> Register with new verbiage</li> </ul>
NVMCTRL	<ul style="list-style-type: none"> <li>Clarified verbiage following Table 27-2 in <a href="#">Memory Organization</a></li> <li>Added new verbiage to line items 1 and 3, and added new line item 4 in <a href="#">Security Bit Set Procedure</a></li> <li>Updated bit names and instructions for setting the Hard lock in <a href="#">Chip Erase Hard Lock</a></li> <li>Updated the notes with new verbiage in <a href="#">Boot Protect Hard Lock</a></li> <li>Removed erroneous text and updated all tables in <a href="#">Immutable Boot, Boot Read Protection and Secure Debug Features Overview</a></li> <li>Updated the table for the PSZ bitfield in the <a href="#">PARAM</a> Register</li> <li>Updated bitfield resets in the <a href="#">SEESTAT</a> Register</li> </ul>
SERCOM USART	<ul style="list-style-type: none"> <li>Clarified verbiage in <a href="#">Data Transmission</a></li> <li>Added a new note to <a href="#">Lin Host</a></li> <li>Added a note to the <a href="#">HDRDLY</a> and <a href="#">BRKLEN</a> bitfields of the <a href="#">CTRLC</a> Register</li> </ul>
TC	<ul style="list-style-type: none"> <li>Added a new line item 4 to the note in <a href="#">Capture Operations</a></li> </ul>
ADC	<ul style="list-style-type: none"> <li>Added a new section <a href="#">Rail-to-Rail Operation</a></li> </ul>
Electrical Specifications	<ul style="list-style-type: none"> <li>Updated Min specifications in the <a href="#">I<sup>2</sup>S Host Mode Electrical Specifications</a> table</li> <li>Modified figure 55-15 in <a href="#">CAN Electrical Specifications</a> to remove an erroneous function</li> </ul>
Electrical Specifications at 125°C	<ul style="list-style-type: none"> <li>Modified figure 56-10 in <a href="#">CAN Electrical Specifications</a> to remove an erroneous function</li> </ul>

## .....continued

Section	Description
Packaging Information	<ul style="list-style-type: none"> <li>Removed obsolete Specification tables from the following packages: <ul style="list-style-type: none"> <li>100-pin TQFP (E5X)</li> <li>100-pin TQFP (with exposed pad)</li> <li>100-pin TFBGA</li> <li>128-pin TQFP</li> <li>128-pin TQFP (with exposed pad)</li> </ul> </li> </ul>

**Revision D - 11/2022**

The following updates were performed in this revision:

Section	Description
Pinout and Packaging	<ul style="list-style-type: none"> <li>Updated values for the ANAREF, CCL, EIC, GMAC, ADC, and the GCLK for the following Pinout tables: <ul style="list-style-type: none"> <li>100-pin TFBGA/100-pin TQFP I/O PINMUX</li> <li>128-pin TQFP I/O PINMUX (PIC32CX SG41)</li> <li>128-pin TQFP I/O PINMUX (PIC32CX SG60/SG61)</li> </ul> </li> </ul>
DMAC	<ul style="list-style-type: none"> <li>Updated the CRCSRC Bitfield of the CRCCTRL register with new channel naming</li> </ul>
SERCOM SPI	<ul style="list-style-type: none"> <li>Added new text for Host and Client mode to the DOPO Bitfield of the CTRLA register</li> </ul>
USB	<ul style="list-style-type: none"> <li>Updated the PCKSIZE register with new Bitfield information for the BYTE_COUNT Bitfield</li> </ul>

.....continued

Section	Description
Electrical Specifications	<ul style="list-style-type: none"> <li>• Replaced and added new tables in the following sections:               <ul style="list-style-type: none"> <li>- MCU Active Current Consumption</li> <li>- MCU Idle Power</li> <li>- MCU Standby Current Consumption</li> <li>- MCU Hibernate Current Consumption</li> <li>- MCU Backup Current Consumption</li> <li>- MCU Off Current Consumption</li> <li>- Peripheral Active Current</li> <li>- AC Electrical Specifications</li> <li>- I<sup>2</sup>S Electrical Specifications</li> <li>- QSPI Electrical Specifications</li> </ul> </li> <li>• Updated the tables in the following sections with new temperature and voltage specifications in the table headings and new minimum/maximum specifications:               <ul style="list-style-type: none"> <li>- Wake-Up Timings Electrical Specifications</li> <li>- I/O Pin Electrical Specifications</li> <li>- Internal Voltage Reference Electrical Specifications</li> <li>- Maximum Clock Frequencies Electrical Specifications</li> <li>- XOSC Maximum Clock Frequencies Electrical Specifications</li> <li>- XOSC32K Electrical Specifications</li> <li>- OSCULP32K Electrical Specifications</li> <li>- DFLL48M Electrical Specifications</li> <li>- FDPLL200M Electrical Specifications</li> <li>- DAC Module Electrical Specifications</li> <li>- ADC Electrical Specifications</li> <li>- PTC Electrical Specifications</li> <li>- SPI Electrical Specifications</li> <li>- USART Electrical Specifications</li> <li>- I<sup>2</sup>C Electrical Specifications</li> <li>- QSPI Electrical Specifications</li> <li>- CAN Electrical Specifications</li> <li>- TC Electrical Specifications</li> <li>- TCC Electrical Specifications</li> <li>- USB Electrical Specifications</li> <li>- PCC Electrical Specifications</li> <li>- NVM Block (Flash, Data Flash, NVM Configuration Rows) Electrical Specifications</li> <li>- EEPROM Electrical Specifications</li> <li>- GMAC Electrical Specifications</li> <li>- FREQM Electrical Specifications</li> <li>- TRNG Electrical Specifications</li> <li>- PDEC Electrical Specifications</li> <li>- SDHC Electrical Specifications</li> <li>- SWD 2-Wire Electrical Specifications</li> </ul> </li> <li>• Replaced the figure for SPI Host Module (CPHA=0) Timing Diagrams in SPI Electrical Specifications</li> </ul>



.....continued	
Section	Description
Electrical Specifications at 125°C	<ul style="list-style-type: none"> <li>New chapter added in this revision</li> </ul>
Schematic Checklist	<ul style="list-style-type: none"> <li>Updated the <a href="#">Introduction</a> with references to other documents</li> <li>Updated <a href="#">External Reset Circuit</a> with a new image for Figure 58-7, and added new text. Removed obsolete diagrams.</li> <li>Updated the text in <a href="#">USB Interface</a> and removed obsolete diagrams</li> </ul>

## Revision C - 08/2022

The following updates were performed in this revision:

Section	Description
Pinout and Packaging	<ul style="list-style-type: none"> <li>Updated the note in the <a href="#">Supply Controller Pinout</a></li> <li>Added a new section called <a href="#">Backup I/O Pins</a></li> </ul>
Signal Descriptions List	<ul style="list-style-type: none"> <li>Updated the listings for the VBAT to include the associated pad name</li> </ul>
Memories	<ul style="list-style-type: none"> <li>Updated the table in <a href="#">NVM Configuration Rows</a> to properly display abbreviations</li> <li>Updated the table in <a href="#">NVM User Row (UROW)</a> to display new default values for bits 0 - 14</li> <li>Updated the titles to display proper abbreviations for:                             <ul style="list-style-type: none"> <li><a href="#">NVM Boot Configuration Row (BOCOR)</a></li> <li><a href="#">NVM Software Calibration Area Row (SW0)</a></li> </ul> </li> </ul>
GCLK	<ul style="list-style-type: none"> <li>Updated the <a href="#">SWRST</a> bit of the <a href="#">CTRLA</a> Register with new notes</li> </ul>
OSC32KCTRL	<ul style="list-style-type: none"> <li>Removed erroneous notes about disabling the Clock Failure Detector from <a href="#">Clock Failure Detection Operation</a></li> </ul>
OSCCTRL	<ul style="list-style-type: none"> <li>Removed erroneous notes about disabling the Clock Failure Detector from <a href="#">Clock Failure Detection Operation</a></li> <li>Added a note to <a href="#">USB Clock Recovery Mode</a> in <a href="#">Additional Features</a></li> </ul>
SUPC	<ul style="list-style-type: none"> <li>Added the proper pad name to VBAT in <a href="#">Features</a></li> <li>Added the proper pad name to VBAT in the <a href="#">Block Diagram</a></li> <li>Added a new note to <a href="#">Signal Description</a></li> <li>Retitled the section <a href="#">Output Pins</a> from backup Output Pins and added a new paragraph</li> <li>Updated the wording of the first paragraph in <a href="#">Enabling, Disabling, and Resetting</a></li> <li>Updated the <a href="#">BKOUT</a> Register to remove the word Backup from the descriptions in the bitfields</li> <li>Updated the <a href="#">BKIN</a> Register to remove the word Backup from the descriptions in the bitfields</li> </ul>
RTC	<ul style="list-style-type: none"> <li>Updated the OUT Signal in the <a href="#">Signal Description</a> to remove erroneous bit definitions</li> <li>Updated the naming of the OUT Register in <a href="#">Tamper Detection</a> and <a href="#">Active Layer Protection</a></li> <li>Added new notes to the SWRST bit for the following registers:                             <ul style="list-style-type: none"> <li><a href="#">Mode 0-32 Bit Counter CTRLA</a></li> <li><a href="#">Mode 1-16 Bit Counter CTRLA</a></li> <li><a href="#">Mode 2 - Clock/Calendar CTRLA</a></li> </ul> </li> </ul>
FREQM	<ul style="list-style-type: none"> <li>Updated the SWRST bit of the <a href="#">CTRLA</a> Register with new notes</li> </ul>

.....continued	
Section	Description
EIC	<ul style="list-style-type: none"> <li>Removed an erroneous note from <a href="#">Initialization</a></li> <li>Removed an erroneous note from <a href="#">Asynchronous Edge Detection Mode (No Debouncing)</a></li> <li>Updated the <a href="#">SWRST</a> bit of the <a href="#">CTRLA</a> Register with new notes, and removed an erroneous note from the <a href="#">ENABLE</a> bit</li> </ul>
NVMCTRL	<ul style="list-style-type: none"> <li>Added a new section of text to <a href="#">Writing and Reading the SmartEEPROM</a></li> <li>Updated the definitions for the <a href="#">SEEWRC</a> bit in the <a href="#">INTFLAG</a> Register</li> <li>Updated the table for the <a href="#">WMODE</a> bit in the <a href="#">SEECFG</a> Register</li> </ul>
PORT	<ul style="list-style-type: none"> <li>Removed erroneous text from the <a href="#">Overview</a></li> <li><a href="#">PORT Access Priority</a> was rewritten to remove obsolete data</li> </ul>
SERCOM USART	<ul style="list-style-type: none"> <li>Minor rewording of terminology in <a href="#">Start-of-Frame Detection</a></li> <li>Updated the <a href="#">SWRST</a> bit of the <a href="#">CTRLA</a> Register with new notes</li> </ul>
SERCOM SPI	<ul style="list-style-type: none"> <li>Added new text to <a href="#">I/O Lines</a> to define registers and bitfields</li> <li>Updated the <a href="#">SWRST</a> bit of the <a href="#">CTRLA</a> Register with new notes</li> </ul>
SERCOM I <sup>2</sup> C	<ul style="list-style-type: none"> <li>Updated the <a href="#">SWRST</a> bit of the <a href="#">Client CTRLA</a> Register with new notes</li> <li>Updated the <a href="#">SWRST</a> bit of the <a href="#">Host CTRLA</a> Register with new notes</li> </ul>
CAN	<ul style="list-style-type: none"> <li>Added new text to the <a href="#">Signal Description</a></li> <li>Updates bit 8-6 to display Reserved in <a href="#">Standard Message ID Filter Element</a></li> </ul>
PCC	<ul style="list-style-type: none"> <li>Updated the <a href="#">Block Diagram</a> with new bits for DATA</li> <li>Updated the <a href="#">Signal Description</a> with new bits for DATA</li> <li>Added in new content for the MCLK APB Clock in <a href="#">Peripheral Dependencies</a></li> <li>Updated the <a href="#">Principle of Operation</a> with new bits for DATA in Figure 39-2</li> </ul>
USB	<ul style="list-style-type: none"> <li>Updated the <a href="#">SWRST</a> bit of the Communication Device Host <a href="#">CTRLA</a> Register with new notes</li> </ul>
PDEC	<ul style="list-style-type: none"> <li>Updated the <a href="#">SWRST</a> bit of the <a href="#">CTRLA</a> Register with new notes</li> </ul>
TC	<ul style="list-style-type: none"> <li>Updated the <a href="#">SWRST</a> bit with new notes in the following registers:                             <ul style="list-style-type: none"> <li>8-bit Mode <a href="#">CTRLA</a></li> <li>16-bit Mode <a href="#">CTRLA</a></li> <li>32-bit Mode <a href="#">CTRLA</a></li> </ul> </li> <li>Replaced the text for the <a href="#">CMD</a> bitfield for the following registers:                             <ul style="list-style-type: none"> <li>8-bit <a href="#">CTRLBCLR</a></li> <li>16-bit <a href="#">CTRLBCLR</a></li> <li>32-bit <a href="#">CTRLBCLR</a></li> <li>8-bit <a href="#">CTRLBSET</a></li> <li>16-bit <a href="#">CTRLBSET</a></li> <li>32-bit <a href="#">CTRLBSET</a></li> </ul> </li> </ul>

.....continued	
Section	Description
TCC	<ul style="list-style-type: none"> <li>Added a new note to <a href="#">Counter Operation</a></li> <li>Updated the SWRST bit of the <a href="#">CTRLA</a> Register with new notes</li> <li>Replaced the text for the CMD bitfield in the <a href="#">CTRLBCLR</a> Register</li> <li>Added new information to the CMD and DIR bitfields for the <a href="#">CTRLBSET</a> Register</li> <li>Added a Register property to the <a href="#">STATUS</a> Register, and removed an obsolete note</li> <li>Updated the Register properties in the following registers: <ul style="list-style-type: none"> <li><a href="#">WAVE</a></li> <li><a href="#">CC</a></li> <li><a href="#">PATTBUF</a></li> <li><a href="#">PERBUF</a></li> <li><a href="#">CCBUF</a></li> </ul> </li> </ul>
ADC	<ul style="list-style-type: none"> <li>Updated the SWRST bit of the <a href="#">CTRLA</a> Register with new notes</li> </ul>
AC	<ul style="list-style-type: none"> <li>Updated DAC to display DAC0 in <a href="#">Features</a></li> <li>Updated DAC to display DAC0 in the <a href="#">Block Diagram</a></li> <li>Added a new note to <a href="#">Window Operation</a></li> <li>Updated the SWRST and ENABLE bits of the <a href="#">CTRLA</a> Register with new notes</li> <li>Added new text to the WSTATE bitfield in the <a href="#">STATUSA</a> Register</li> <li>Renamed the COMPCTRL Register to <a href="#">COMPCTRLn</a> and updated the table definitions for the <a href="#">HYST</a> bitfield</li> </ul>
DAC	<ul style="list-style-type: none"> <li>Updated the SWRST bit of the <a href="#">CTRLA</a> Register with new notes</li> </ul>
PIC32CX SG41/SG60/SG61 Electrical Specifications	<ul style="list-style-type: none"> <li>Updated values for <a href="#">Absolute Maximum Ratings</a></li> <li>Minor formatting updates in <a href="#">Power Supply</a></li> <li>Minor formatting updates to the <a href="#">ADC Electrical Specifications table</a></li> <li>Updated the units for CMP_19 in <a href="#">AC Electrical Specifications</a></li> <li>Minor updates to the specifications for TCC_15 and TCC_17 in <a href="#">TCC Timer Capture Module Electrical Specifications</a></li> <li>Added new Min and max values to the <a href="#">SD Host Controller Timing Specifications</a></li> </ul>
Schematic Checklist	<ul style="list-style-type: none"> <li>Updated the pad name for VBAT in the <a href="#">Power Supply Connections table</a></li> </ul>

## Revision B - 01/2022

The following updates were performed in this revision:

Terminology used in this document may not match with the contents of the current revision of the device errata or other Microchip documentation and collateral. If there are any questions or concerns regarding terminology, contact a Microchip Support or Sales Representative.

Section	Description
General	<ul style="list-style-type: none"> <li>Throughout the document, VDDANA and GNDANA were updated to read AVDD and AVSS respectively</li> <li>Throughout the document, VDDIO and GND were updated to read VDD and VSS respectively</li> <li>The I<sup>2</sup>C, SPI and I<sup>2</sup>S standards use the terminology "Master" and "Slave". The equivalent Microchip terminology used in this document is "Host" and "Client" respectively.</li> <li>Removed erroneous references to a temperature sensor from the entire document</li> </ul>

.....continued	
Section	Description
Features	Updated the specifications for the following subsections: <ul style="list-style-type: none"> <li>• I/O</li> <li>• Clock Management</li> <li>• System</li> <li>• <a href="#">Package Types</a> table</li> </ul>
Configuration Summary	Reformatted the entire table and added a Max Frequency column.
Pinout and Packaging	Updated the following packages with several new pin names: <ul style="list-style-type: none"> <li>• <a href="#">100-pin TFBGA and 100-pin TQFP</a></li> <li>• <a href="#">128-pin TQFP</a></li> </ul>
Power Supply and Startup Considerations	<ul style="list-style-type: none"> <li>• Updated the Voltage range specifications in <a href="#">6. Power Supplies</a>.</li> <li>• Reworked and restructured the entire chapter</li> </ul>
SUPC	Updated the <a href="#">ACTION</a> bit for the <a href="#">BOD33</a> Register to clarify bit naming.
EIC	Removed erroneous references to another product from: <ul style="list-style-type: none"> <li>• <a href="#">Features</a></li> <li>• <a href="#">Interrupt Pin Debouncing</a></li> </ul>
FREQM	Removed the note from the <a href="#">Block Diagram</a> .
SERCOM SPI	<ul style="list-style-type: none"> <li>• Replaced all <a href="#">_SS</a> with <a href="#">SS</a></li> <li>• Removed duplicate text sections from <a href="#">Transferring Data</a></li> </ul>
HSM	<ul style="list-style-type: none"> <li>• Replaced the content in <a href="#">Overview</a></li> <li>• Clarified the SPI interface in <a href="#">Features</a></li> <li>• Updated the title and removed erroneous text in <a href="#">Application</a></li> <li>• Removed the <a href="#">Block Diagram</a></li> <li>• Added in a new topic, <a href="#">I/O Lines</a></li> <li>• Updated <a href="#">Debug Operation</a> with new text</li> <li>• Clarified the text in the <a href="#">Functional Description</a></li> </ul>
TC	Removed references to a different product from <a href="#">Features</a> .
TCC	Updated erroneous references to the TC to read TCC in the EVACT bitfields of the <a href="#">EVCTRL</a> register.
PDEC	<ul style="list-style-type: none"> <li>• Updated the following sections with all new text and images:                                     <ul style="list-style-type: none"> <li>– <a href="#">Position and Rotation Measurement</a></li> <li>– <a href="#">HALL Operation Mode</a></li> </ul> </li> <li>• Updated <a href="#">Hall Sensor Control</a> with new bulleted text</li> <li>• Updated the Bit naming and numbering for the <a href="#">PINVENx</a> and <a href="#">PINENx</a> bitfields in the <a href="#">CTRLA</a> Register</li> <li>• Updated the bit naming and numbering for the <a href="#">MCEOx</a>, <a href="#">EVEIx</a> and the <a href="#">EVINVx</a> bitfields in the <a href="#">EVCTRL</a> Register</li> </ul>
AC	Updated COMPCTRLx to COMPCTRLn throughout the entire chapter.
<a href="#">PIC32CX SG41/SG60/SG61 Electrical Specifications</a>	Added Electrical Specifications for the product.

.....continued	
Section	Description
Packaging Information	<ul style="list-style-type: none"> <li>Updated Figure <a href="#">54-1</a> and <a href="#">54-2</a></li> <li>Updated the Device and Package Maximum Weight tables for the following packages:                             <ul style="list-style-type: none"> <li><a href="#">128-pin TQFP</a></li> <li><a href="#">128-pin TQFP (with exposed pad)</a></li> </ul> </li> </ul>
Schematic Checklist	<ul style="list-style-type: none"> <li>Removed erroneous content from <a href="#">Power Supply</a></li> <li>Updated <a href="#">Power Supply Connections</a> with all new figures and updated the notes at the end of the section</li> <li>Replaced the text in <a href="#">Special Consideration for Packages with an Exposed Pad</a></li> <li>Replaced the text, table and figures in <a href="#">External Analog Reference Connections</a></li> <li>Replaced the text in <a href="#">External Reset Circuit</a></li> <li>Replaced the text in <a href="#">Unused or Unconnected Pins</a></li> <li>Updated the content for the Description column for the table in <a href="#">External Clock Source</a></li> <li>Updated the figure with new C1 and C2 information, and added all new content to the table in <a href="#">Crystal Oscillator</a></li> <li>Renamed External Real Time Oscillator to <a href="#">32.768 kHz Crystal Oscillator</a>, replaced the text and table with new content</li> <li>Updated <a href="#">Programming and Debug</a> with all new content</li> <li>Updated the figure in Trace (CoreSight 20) Connector</li> <li>Removed the table and updated the figure in QSPI Interface.</li> <li>Updated the first paragraph in <a href="#">USB Interface</a></li> <li>Updated the figure in SDHC Interface.</li> <li>Added the following new topics/sections to the Schematic Checklist section:                             <ul style="list-style-type: none"> <li><a href="#">Decoupling Capacitors</a></li> <li><a href="#">Debugging or Programming Pins</a></li> <li><a href="#">Designing for High-Speed Peripherals</a></li> </ul> </li> </ul>

### Revision A - 07/2021

This is the initial release of this document.

Terminology used in this document may not match with the contents of the current revision of the device errata or other Microchip documentation and collateral. If there are any questions or concerns regarding terminology, contact a Microchip Support or Sales Representative.

## Microchip Information

### The Microchip Website

Microchip provides online support via our website at [www.microchip.com/](http://www.microchip.com/). This website is used to make files and information easily available to customers. Some of the content available includes:

- **Product Support** – Data sheets and errata, application notes and sample programs, design resources, user's guides and hardware support documents, latest software releases and archived software
- **General Technical Support** – Frequently Asked Questions (FAQs), technical support requests, online discussion groups, Microchip design partner program member listing
- **Business of Microchip** – Product selector and ordering guides, latest Microchip press releases, listing of seminars and events, listings of Microchip sales offices, distributors and factory representatives

### Product Change Notification Service

Microchip's product change notification service helps keep customers current on Microchip products. Subscribers will receive email notification whenever there are changes, updates, revisions or errata related to a specified product family or development tool of interest.

To register, go to [www.microchip.com/pcn](http://www.microchip.com/pcn) and follow the registration instructions.

### Customer Support

Users of Microchip products can receive assistance through several channels:

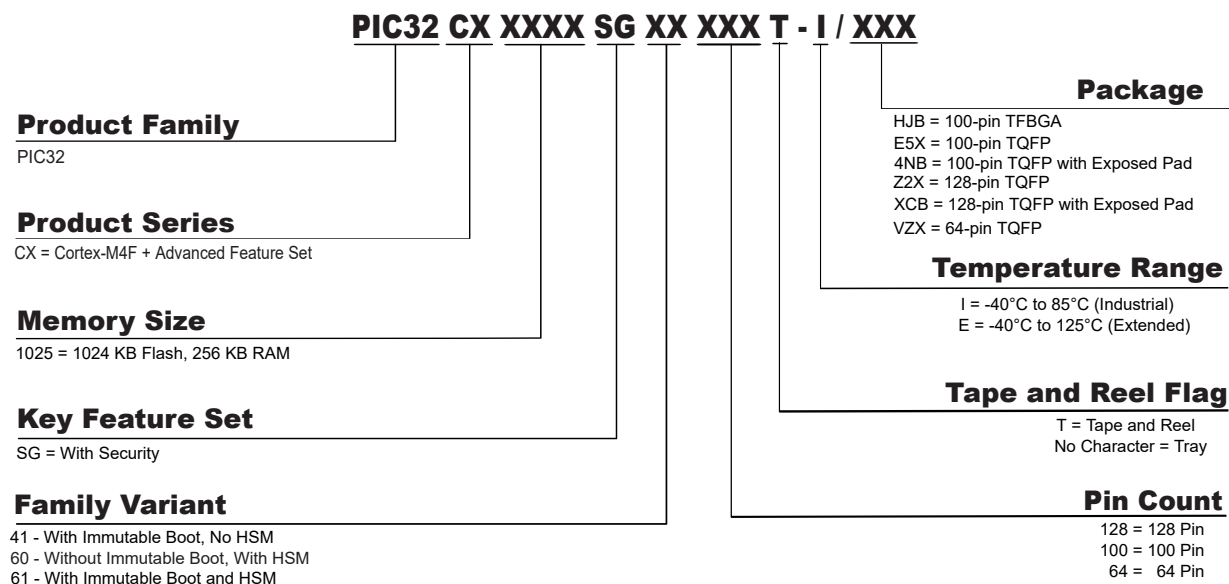
- Distributor or Representative
- Local Sales Office
- Embedded Solutions Engineer (ESE)
- Technical Support

Customers should contact their distributor, representative or ESE for support. Local sales offices are also available to help customers. A listing of sales offices and locations is included in this document.

Technical support is available through the website at: [www.microchip.com/support](http://www.microchip.com/support)

## Product Identification System

To order or obtain information, e.g., on pricing or delivery, refer to the factory or the listed sales office.



## Microchip Devices Code Protection Feature

Note the following details of the code protection feature on Microchip products:

- Microchip products meet the specifications contained in their particular Microchip Data Sheet.
- Microchip believes that its family of products is secure when used in the intended manner, within operating specifications, and under normal conditions.
- Microchip values and aggressively protects its intellectual property rights. Attempts to breach the code protection features of Microchip product is strictly prohibited and may violate the Digital Millennium Copyright Act.
- Neither Microchip nor any other semiconductor manufacturer can guarantee the security of its code. Code protection does not mean that we are guaranteeing the product is “unbreakable”. Code protection is constantly evolving. Microchip is committed to continuously improving the code protection features of our products.

## Legal Notice

This publication and the information herein may be used only with Microchip products, including to design, test, and integrate Microchip products with your application. Use of this information in any other manner violates these terms. Information regarding device applications is provided only for your convenience and may be superseded by updates. It is your responsibility to ensure that your application meets with your specifications. Contact your local Microchip sales office for additional support or, obtain additional support at [www.microchip.com/en-us/support/design-help/client-support-services](http://www.microchip.com/en-us/support/design-help/client-support-services).

THIS INFORMATION IS PROVIDED BY MICROCHIP "AS IS". MICROCHIP MAKES NO REPRESENTATIONS OR WARRANTIES OF ANY KIND WHETHER EXPRESS OR IMPLIED, WRITTEN OR ORAL, STATUTORY OR OTHERWISE, RELATED TO THE INFORMATION INCLUDING BUT NOT LIMITED TO ANY IMPLIED WARRANTIES OF NON-INFRINGEMENT, MERCHANTABILITY, AND FITNESS FOR A PARTICULAR PURPOSE, OR WARRANTIES RELATED TO ITS CONDITION, QUALITY, OR PERFORMANCE.

IN NO EVENT WILL MICROCHIP BE LIABLE FOR ANY INDIRECT, SPECIAL, PUNITIVE, INCIDENTAL, OR CONSEQUENTIAL LOSS, DAMAGE, COST, OR EXPENSE OF ANY KIND WHATSOEVER RELATED TO THE INFORMATION OR ITS USE, HOWEVER CAUSED, EVEN IF MICROCHIP HAS BEEN ADVISED OF THE POSSIBILITY OR THE DAMAGES ARE FORESEEABLE. TO THE FULLEST EXTENT ALLOWED BY LAW, MICROCHIP'S TOTAL LIABILITY ON ALL CLAIMS IN ANY WAY RELATED TO THE INFORMATION OR ITS USE WILL NOT EXCEED THE AMOUNT OF FEES, IF ANY, THAT YOU HAVE PAID DIRECTLY TO MICROCHIP FOR THE INFORMATION.

Use of Microchip devices in life support and/or safety applications is entirely at the buyer's risk, and the buyer agrees to defend, indemnify and hold harmless Microchip from any and all damages, claims, suits, or expenses resulting from such use. No licenses are conveyed, implicitly or otherwise, under any Microchip intellectual property rights unless otherwise stated.

## Trademarks

The Microchip name and logo, the Microchip logo, Adaptec, AVR, AVR logo, AVR Freaks, BesTime, BitCloud, CryptoMemory, CryptoRF, dsPIC, flexPWR, HELDO, IGLOO, JukeBlox, KeeLoq, Kleer, LANCheck, LinkMD, maXStylus, maXTouch, MediaLB, megaAVR, Microsemi, Microsemi logo, MOST, MOST logo, MPLAB, OptoLyzer, PIC, picoPower, PICSTART, PIC32 logo, PolarFire, Prochip Designer, QTouch, SAM-BA, SenGenuity, SpyNIC, SST, SST Logo, SuperFlash, Symmetricom, SyncServer, Tachyon, TimeSource, tinyAVR, UNI/O, Vectron, and XMEGA are registered trademarks of Microchip Technology Incorporated in the U.S.A. and other countries.

AgileSwitch, APT, ClockWorks, The Embedded Control Solutions Company, EtherSynch, Flashtec, Hyper Speed Control, HyperLight Load, Libero, motorBench, mTouch, Powermite 3, Precision Edge, ProASIC, ProASIC Plus, ProASIC Plus logo, Quiet-Wire, SmartFusion, SyncWorld, Temux, TimeCesium, TimeHub, TimePictra, TimeProvider, TrueTime, and ZL are registered trademarks of Microchip Technology Incorporated in the U.S.A.

Adjacent Key Suppression, AKS, Analog-for-the-Digital Age, Any Capacitor, AnyIn, AnyOut, Augmented Switching, BlueSky, BodyCom, Clockstudio, CodeGuard, CryptoAuthentication, CryptoAutomotive, CryptoCompanion, CryptoController, dsPICDEM, dsPICDEM.net, Dynamic Average Matching, DAM, ECAN, Espresso T1S, EtherGREEN, GridTime, IdealBridge, In-Circuit Serial Programming, ICSP, INICnet, Intelligent Paralleling, IntelliMOS, Inter-Chip Connectivity, JitterBlocker, Knob-on-Display, KoD, maxCrypto, maxView, memBrain, Mindi, MiWi, MPASM, MPF, MPLAB Certified logo, MPLIB, MPLINK, MultiTRAK, NetDetach, Omniscient Code Generation, PICDEM, PICDEM.net, PICkit, PICtail, PowerSmart, PureSilicon, QMatrix, REAL ICE, Ripple Blocker, RTAX, RTG4, SAM-ICE, Serial Quad I/O, simpleMAP, SimpliPHY, SmartBuffer, SmartHLS, SMART-I.S., storClad, SQL, SuperSwitcher, SuperSwitcher II, Switchtec, SynchroPHY, Total Endurance, Trusted Time, TSHARC, USBCheck, VariSense, VectorBlox, VeriPHY, ViewSpan, WiperLock, XpressConnect, and ZENA are trademarks of Microchip Technology Incorporated in the U.S.A. and other countries.

SQTP is a service mark of Microchip Technology Incorporated in the U.S.A.

The Adaptec logo, Frequency on Demand, Silicon Storage Technology, and Symmcom are registered trademarks of Microchip Technology Inc. in other countries.

GestIC is a registered trademark of Microchip Technology Germany II GmbH & Co. KG, a subsidiary of Microchip Technology Inc., in other countries.

All other trademarks mentioned herein are property of their respective companies.

© 2023, Microchip Technology Incorporated and its subsidiaries. All Rights Reserved.

ISBN: 978-1-6683-3005-0

## Quality Management System

For information regarding Microchip's Quality Management Systems, please visit [www.microchip.com/quality](http://www.microchip.com/quality).



# Worldwide Sales and Service

AMERICAS	ASIA/PACIFIC	ASIA/PACIFIC	EUROPE
<p><b>Corporate Office</b> 2355 West Chandler Blvd. Chandler, AZ 85224-6199 Tel: 480-792-7200 Fax: 480-792-7277 Technical Support: <a href="http://www.microchip.com/support">www.microchip.com/support</a> Web Address: <a href="http://www.microchip.com">www.microchip.com</a></p> <p><b>Atlanta</b> Duluth, GA Tel: 678-957-9614 Fax: 678-957-1455</p> <p><b>Austin, TX</b> Tel: 512-257-3370</p> <p><b>Boston</b> Westborough, MA Tel: 774-760-0087 Fax: 774-760-0088</p> <p><b>Chicago</b> Itasca, IL Tel: 630-285-0071 Fax: 630-285-0075</p> <p><b>Dallas</b> Addison, TX Tel: 972-818-7423 Fax: 972-818-2924</p> <p><b>Detroit</b> Novi, MI Tel: 248-848-4000</p> <p><b>Houston, TX</b> Tel: 281-894-5983</p> <p><b>Indianapolis</b> Noblesville, IN Tel: 317-773-8323 Fax: 317-773-5453 Tel: 317-536-2380</p> <p><b>Los Angeles</b> Mission Viejo, CA Tel: 949-462-9523 Fax: 949-462-9608 Tel: 951-273-7800</p> <p><b>Raleigh, NC</b> Tel: 919-844-7510</p> <p><b>New York, NY</b> Tel: 631-435-6000</p> <p><b>San Jose, CA</b> Tel: 408-735-9110 Tel: 408-436-4270</p> <p><b>Canada - Toronto</b> Tel: 905-695-1980 Fax: 905-695-2078</p>	<p><b>Australia - Sydney</b> Tel: 61-2-9868-6733</p> <p><b>China - Beijing</b> Tel: 86-10-8569-7000</p> <p><b>China - Chengdu</b> Tel: 86-28-8665-5511</p> <p><b>China - Chongqing</b> Tel: 86-23-8980-9588</p> <p><b>China - Dongguan</b> Tel: 86-769-8702-9880</p> <p><b>China - Guangzhou</b> Tel: 86-20-8755-8029</p> <p><b>China - Hangzhou</b> Tel: 86-571-8792-8115</p> <p><b>China - Hong Kong SAR</b> Tel: 852-2943-5100</p> <p><b>China - Nanjing</b> Tel: 86-25-8473-2460</p> <p><b>China - Qingdao</b> Tel: 86-532-8502-7355</p> <p><b>China - Shanghai</b> Tel: 86-21-3326-8000</p> <p><b>China - Shenyang</b> Tel: 86-24-2334-2829</p> <p><b>China - Shenzhen</b> Tel: 86-755-8864-2200</p> <p><b>China - Suzhou</b> Tel: 86-186-6233-1526</p> <p><b>China - Wuhan</b> Tel: 86-27-5980-5300</p> <p><b>China - Xian</b> Tel: 86-29-8833-7252</p> <p><b>China - Xiamen</b> Tel: 86-592-2388138</p> <p><b>China - Zhuhai</b> Tel: 86-756-3210040</p>	<p><b>India - Bangalore</b> Tel: 91-80-3090-4444</p> <p><b>India - New Delhi</b> Tel: 91-11-4160-8631</p> <p><b>India - Pune</b> Tel: 91-20-4121-0141</p> <p><b>Japan - Osaka</b> Tel: 81-6-6152-7160</p> <p><b>Japan - Tokyo</b> Tel: 81-3-6880-3770</p> <p><b>Korea - Daegu</b> Tel: 82-53-744-4301</p> <p><b>Korea - Seoul</b> Tel: 82-2-554-7200</p> <p><b>Malaysia - Kuala Lumpur</b> Tel: 60-3-7651-7906</p> <p><b>Malaysia - Penang</b> Tel: 60-4-227-8870</p> <p><b>Philippines - Manila</b> Tel: 63-2-634-9065</p> <p><b>Singapore</b> Tel: 65-6334-8870</p> <p><b>Taiwan - Hsin Chu</b> Tel: 886-3-577-8366</p> <p><b>Taiwan - Kaohsiung</b> Tel: 886-7-213-7830</p> <p><b>Taiwan - Taipei</b> Tel: 886-2-2508-8600</p> <p><b>Thailand - Bangkok</b> Tel: 66-2-694-1351</p> <p><b>Vietnam - Ho Chi Minh</b> Tel: 84-28-5448-2100</p>	<p><b>Austria - Wels</b> Tel: 43-7242-2244-39 Fax: 43-7242-2244-393</p> <p><b>Denmark - Copenhagen</b> Tel: 45-4485-5910 Fax: 45-4485-2829</p> <p><b>Finland - Espoo</b> Tel: 358-9-4520-820</p> <p><b>France - Paris</b> Tel: 33-1-69-53-63-20 Fax: 33-1-69-30-90-79</p> <p><b>Germany - Garching</b> Tel: 49-8931-9700</p> <p><b>Germany - Haan</b> Tel: 49-2129-3766400</p> <p><b>Germany - Heilbronn</b> Tel: 49-7131-72400</p> <p><b>Germany - Karlsruhe</b> Tel: 49-721-625370</p> <p><b>Germany - Munich</b> Tel: 49-89-627-144-0 Fax: 49-89-627-144-44</p> <p><b>Germany - Rosenheim</b> Tel: 49-8031-354-560</p> <p><b>Israel - Ra'anana</b> Tel: 972-9-744-7705</p> <p><b>Italy - Milan</b> Tel: 39-0331-742611 Fax: 39-0331-466781</p> <p><b>Italy - Padova</b> Tel: 39-049-7625286</p> <p><b>Netherlands - Drunen</b> Tel: 31-416-690399 Fax: 31-416-690340</p> <p><b>Norway - Trondheim</b> Tel: 47-72884388</p> <p><b>Poland - Warsaw</b> Tel: 48-22-3325737</p> <p><b>Romania - Bucharest</b> Tel: 40-21-407-87-50</p> <p><b>Spain - Madrid</b> Tel: 34-91-708-08-90 Fax: 34-91-708-08-91</p> <p><b>Sweden - Gothenberg</b> Tel: 46-31-704-60-40</p> <p><b>Sweden - Stockholm</b> Tel: 46-8-5090-4654</p> <p><b>UK - Wokingham</b> Tel: 44-118-921-5800 Fax: 44-118-921-5820</p>