

Eight Channel $\pm 60V$, $\pm 1.0A$, Ultrasound Pulser Demoboard

General Description

The HV7350 is a monolithic eight channel, high-speed, high voltage, ultrasound transmitter RTZ pulser. This integrated, high performance circuit is in a single, 8x8x0.9 mm, 56-lead QFN package.

The HV7350 can deliver a guaranteed $\pm 1.0A$ source and sink current to a capacitive transducer with $\pm 60V$ peak to peak voltage. It is designed for portable medical ultrasound imaging and ultrasound NDT applications. It can also be used as a high voltage driver for other piezoelectric or capacitive MEMS transducers, or for test systems as a signal source or pulse signal generators.

The HV7350's circuitry consists of controller logic circuits, level translators, gate driving buffers and a high current and high voltage MOSFET output stage. The output stages of each channel are designed to provide peak output currents typically over $\pm 1.0A$ for pulsing, with up to $\pm 60V$ swings in RTZ mode. The upper limit frequency of the pulser waveform is depending on the load capacitance.

This demoboard datasheet describes how to use the HV7350DB1 to generate the basic high voltage pulse waveform as an ultrasound transmitting pulser.

The HV7350 circuit uses DC coupling from a 3.3V logic input to output Tx1~8 internally, therefore the chip needs three sets of voltage supply rails: $V_{LL} +3.3V$, $V_{DD} +5.0V$ and $V_{PP}/V_{NN} \pm 10$ to $\pm 60V$. The V_{PP} and V_{NN} rail voltages can be changed rather quickly, compared to the capacitor gate-coupled driving pulsers. This direct coupling topology of the gate drivers not only saves two high voltage capacitors per channel, but also makes the PCB layout easier.

The HV7350DB1 output waveforms can be displayed using an oscilloscope by connecting the scope probe directly to the test points TX1~8 and GND. The soldering jumper can select whether or not to connect the on-board dummy-load, a 330pF capacitor paralleling with a 2.5k Ω resistor. The test points can be used to connect the user's transducer to easily evaluate the pulser.

Block Diagram

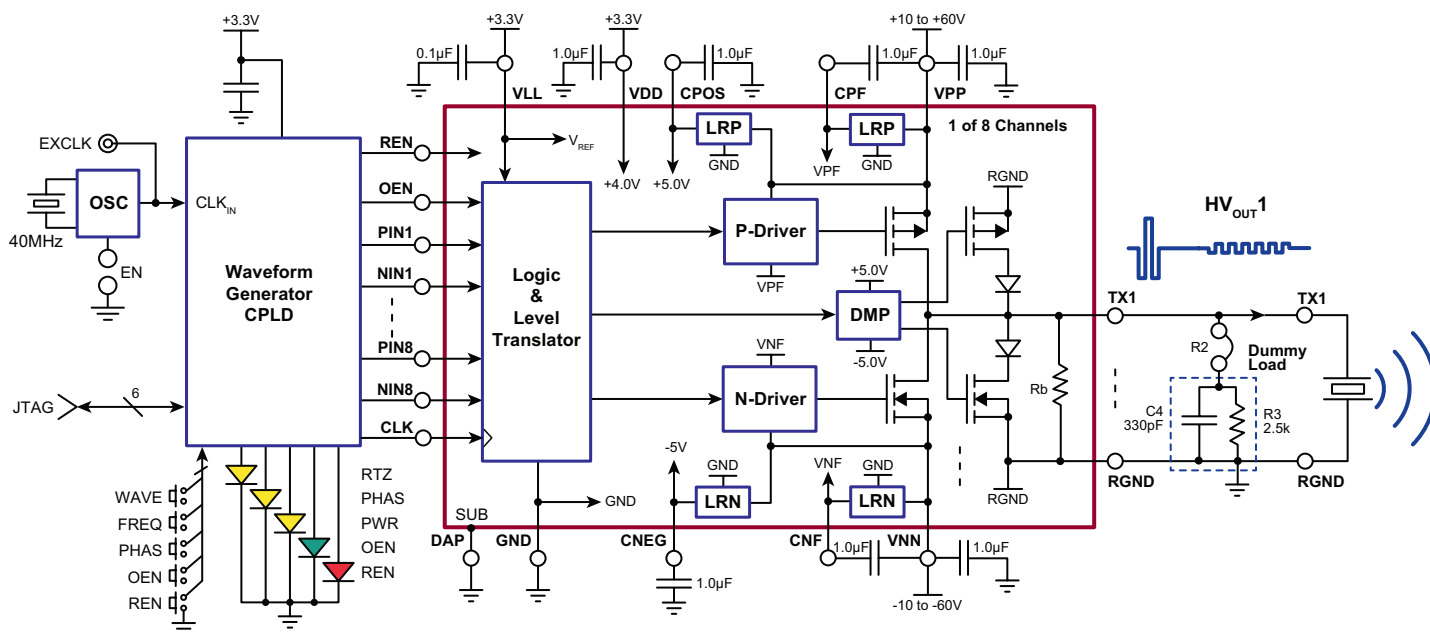

The PCB Layout Techniques

The large thermal pad at the bottom of the HV7350 package is internally connected to the IC's substrate (V_{SUB}). This thermal pad should be connected to 0V or GND externally on the PCB. Designers need to pay attention to the connecting traces on the outputs TX1~8, specifically the high voltage and high speed traces. In particular, controlled impedance to the ground plane and more trace spacing needs to be applied in this situation.

High speed PCB trace design practices that are compatible with about 50 to 100MHz operating speeds are used for the demoboard PCB layout. The internal circuitry of the HV7350 can operate at quite a high frequency, with the primary speed limitation being load capacitance. Because of this high speed and the high transient currents that result when driving capacitive loads, the supply voltage bypass capacitors and the driver to the FET's gate-coupling capacitors should be as close to the pins as possible. The GND pin should have low inductance feed-through via connections that are connected directly to a solid ground plane. The VDD, VPP, VNN, CPF, CNF, CNEG and CPOS voltage supply and/or bypass capacitor pins can draw fast transient currents of up to $\pm 2.0A$, so they should be provided with a low impedance bypass capacitor at the chip's pins. A ceramic capacitor of 1.0 to 2.0 μF may be used. Only the VPP and VNN pins to GND capacitors need to be the high-voltage type. The CPF to VPP and CNF to VNN capacitors maybe low voltage. Minimize the trace length to the ground plane, and insert a ferrite bead in the power supply lead to the capacitor to prevent resonance in the power supply lines. For applications that are sensitive to jitter and noise and using multiple HV7350 ICs, insert another ferrite bead between each chip's supply lines.

Pay particular attention to minimizing trace lengths and using sufficient trace width to reduce inductance. Surface mount components are highly recommended. Since the output impedance of the HV7350's high voltage power stages is very low, in some cases it may be desirable to add a small value resistor in series with the output TX1~8 to obtain better waveform integrity at the load terminals after long cables. This will, of course, reduce the output voltage slew rate at the terminals of a capacitive load.

Be aware of the parasitic coupling from the outputs to the input signal terminals of the HV7350. This feedback may cause oscillations or spurious waveform shapes on the edges of the signal transitions. Since the input operates with signals down to 3.3V, even small coupling voltages may cause problems. Use of a solid ground plane and good power and signal layout practices will prevent this problem. Also ensure that the circulating ground return current from a capacitive load cannot react with common inductance to create noise voltages in the input logic circuitry.

Testing the Integrated Pulser

The HV7350 pulser demoboard should be powered up with multiple lab DC power supplies with current limiting functions.

The on-board dummy load 330pF//2.5k Ω should be connected to the high voltage pulser output through the solder jumper when using an oscilloscope's high impedance probe to meet the typical loading condition. To evaluate different loading conditions, one may change the values of RC within the current and power limit of the device.

In order to drive the user's piezo transducers with a cable, one should match the output load impedance properly to avoid cable and transducer reflections. A 70 to 75 Ω coaxial cable is recommended. The coaxial cable end should be soldered to the TX1~8 and GND directly with very short leads. If a user's load is being used, the on-board dummy load should be disconnected by cutting the small shorting copper trace in between the 0 Ω resistors R2, R9, R12, R18, R23, R53, R54 or R55 pads. They are shorted by factory default.

All the on-board test points are designed to work with the high impedance probe of the oscilloscope. Some probes may have limited input voltage. When using the probe on these high voltage test-points, make sure that V_{PP}/V_{NN} voltages do not exceed the probe limit. Using the high impedance oscilloscope probe for the on-board test points, it is important to have short ground leads to the circuit board ground plane.

If both of the inputs PIN and NIN are high, then the channel out TX will be in Hi-Z.

HV7350DB1 Schematic

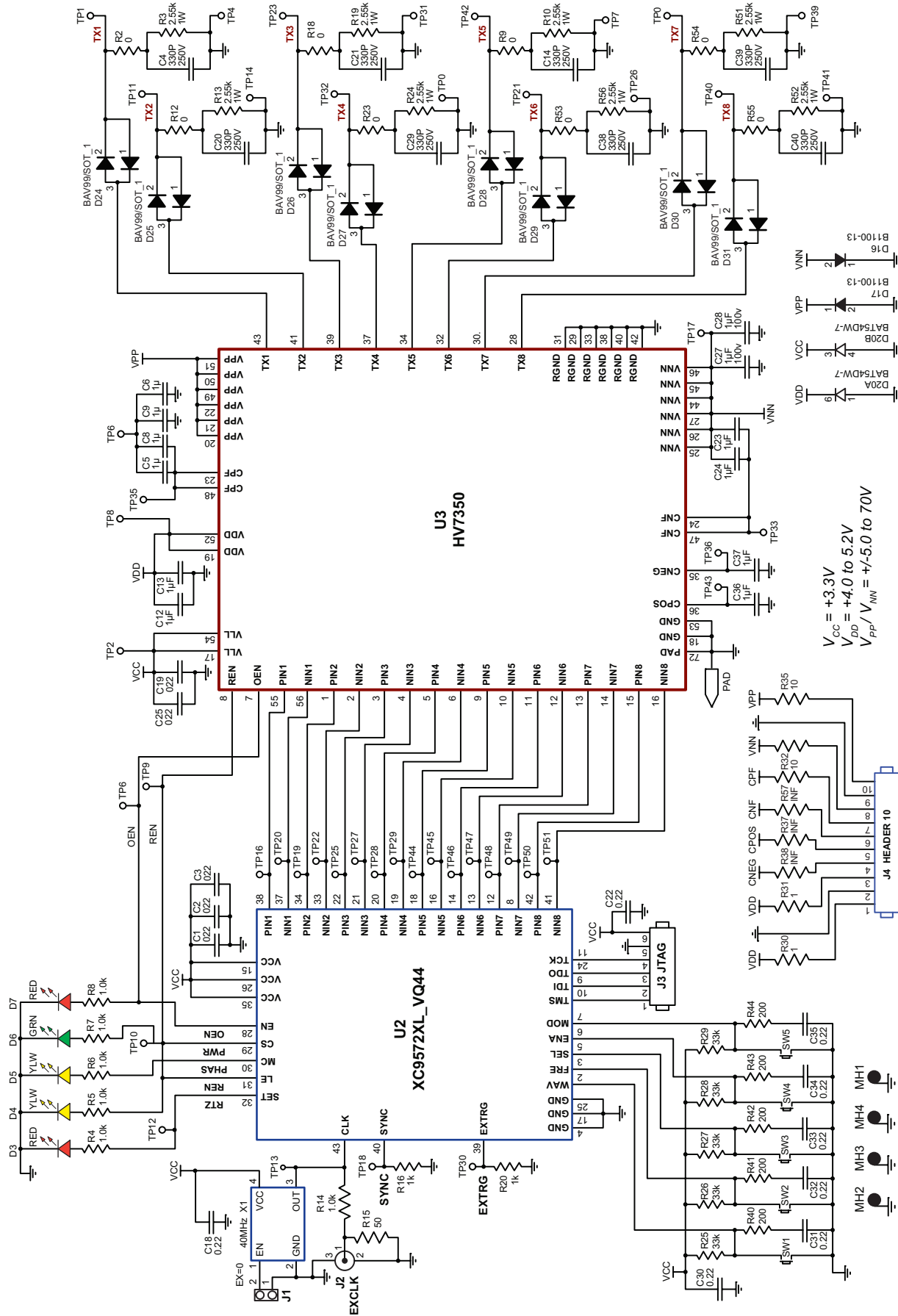

Note: J4-4, 5 & 6 & 7 - pins for test only

HV7350DB1 PCB and Board Layout

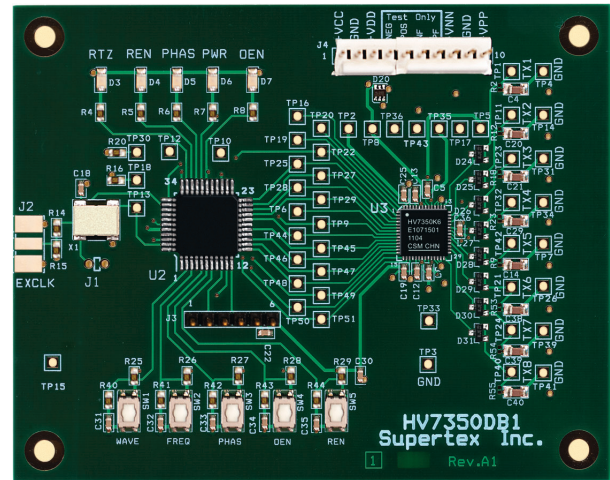
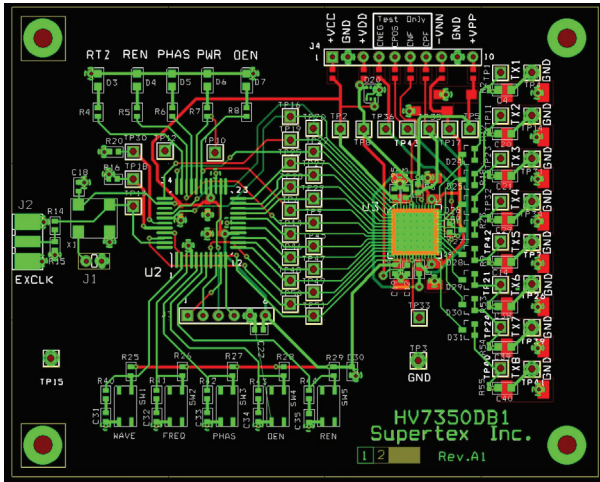

Actual Board Size: 72.4mm x 68.4mm

Power Connector Description

1	+V _{CC}	+3.3V Logic voltage input for V _{LL} and CPLD. (100mA)
2	GND	0V, Ground
3	+V _{DD}	+5.0V HV7350 positive V _{DD} supply. (25mA)
4	CNEG	-5.0V HV7350 negative V _{NEG} supply, only when REN=0
5	CPOS	+5.0V HV7350 Positive V _{POS} supply, only when REN=0
6	CNF	HV7350 V _{NF} supply reference to V _{NN} , (V _{NF} - V _{NN}) = +5.0V, only when REN=0
7	CPF	HV7350 V _{PF} supply reference to V _{PP} , (V _{PP} - V _{PF}) = +5.0V, only when REN=0
8	-V _{NN}	-10 to -60V negative high voltage supply. (-5.0mA)
9	GND	0V, Ground
10	+V _{PP}	+10 to +60V positive high voltage supply. (+5.0mA)

Note: J4-4 to 7 are for external power connection of V_{NEG}, V_{POS}, V_{NF}, V_{PP} when REN = 0. Note, as default the resistors R34, R37, R38 and R57 is not installed. Do not need to connect these four pins to any power supply when internal regulators are be used when REN=1.

Voltage Supply Power-Up and Operation Sequence

1	+V _{CC}	Power on +3.3V positive logic supply voltage for HV7350's V _{LL} and CPLD V _{CC}
2	+V _{DD}	Power on +5.0V V _{DD} positive supply
3	OEN & REN	Turn both OEN & REN LED off
4	+V _{PP} / -V _{NN}	Power on V _{PP} /V _{NN} = ±10 to 60V positive and negative high voltage supply
5	OEN & REN	Turn on OEN & REN LED on
6	WAVE Button	Push WAVE button to select waveforms

Note: Power-down in the 6,5... to 1 reversing order.

Push Button Operations

WAV	Toggle select pulse B-mode waveforms: None, 1-cycle, 1-cycle inverting, 3-cycle & 3-cycle inverting
FREQ	Toggle select B-mode demo frequency of 10, 5, 2.5, 1.25 & 0.625MHz when X1 oscillator is 40MHz
PHAS	Toggle select B-mode waveform phase polarity
OEN	Toggle on or off HV7350 chip output signal OEN
REN	Toggle select on or off HV7350 internal voltage-regulators signal REN

LED Indicator

RTZ	RTZ indication, default is on
PHAS	Phase polarity indication
PWR	HV7350DB1 V_{LL} 3.3V and CPLD chip V_{CC} power supply indication
OEN	HV7350 chip enable EN signal indication, power on default is off until OEN button is pushed
REN	HV7350 built-in regulators enable indication, power on default is off until REN button is pushed

Typical Waveforms

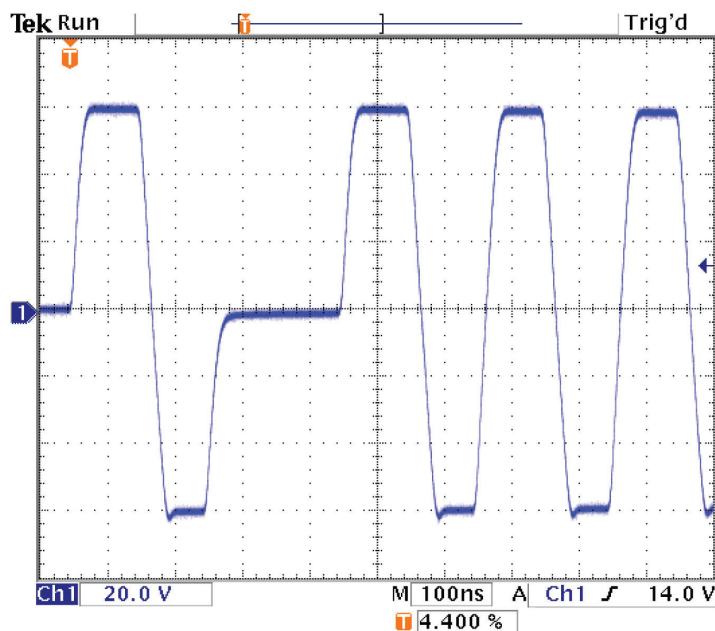

Figure 1. $V_{PP}/V_{NN} = +/-60V$ 5MHz with 330pF//2.5k Ω load and 8-Channel pulsing

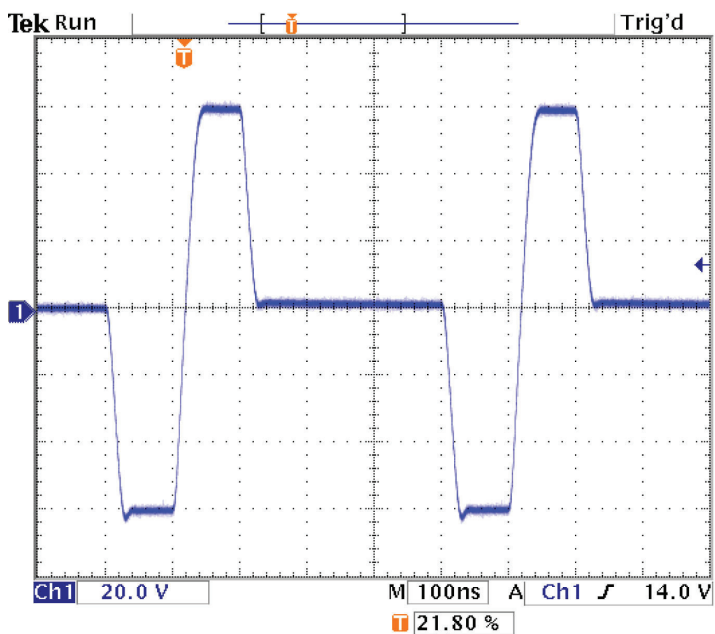

Figure 2. $V_{PP}/V_{NN} = +/-60V$ 5MHz with 330pF//2.5k Ω load and 8-Channel pulsing

Typical Waveforms (cont.)

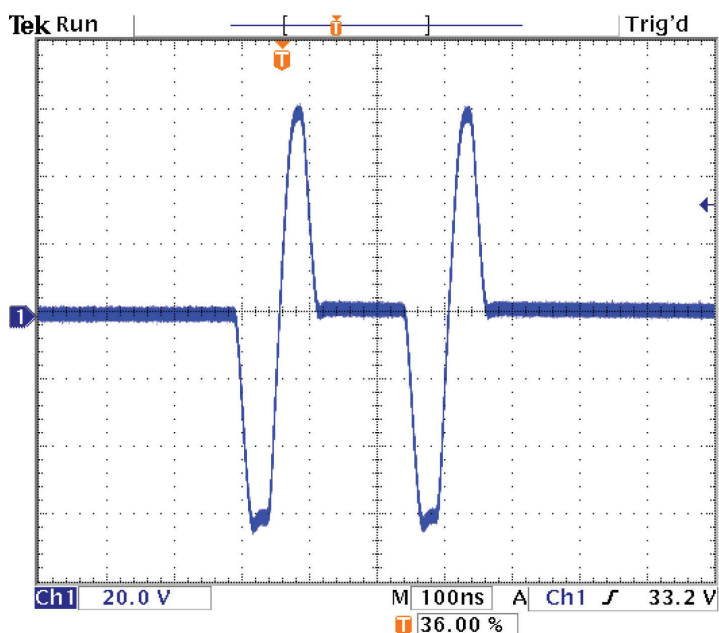

Figure 3. $V_{PP}/V_{NN} = +/-60V$ 10MHz with 330pF//2.5kΩ load and 8-Channel pulsing

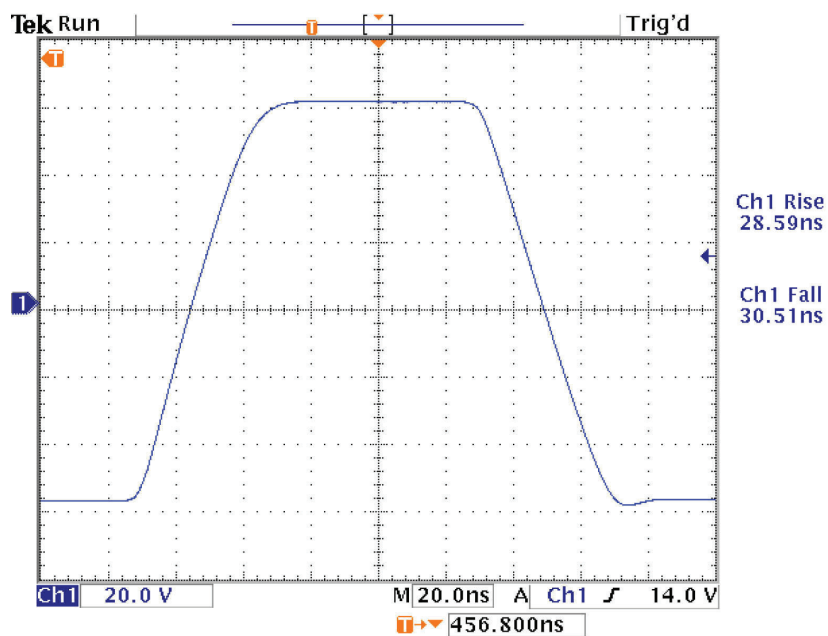

Figure 4. Rise and Fall time at $V_{PP}/V_{NN} = +/-60V$ with 330pF//2.5kΩ load

Typical Waveforms (cont.)

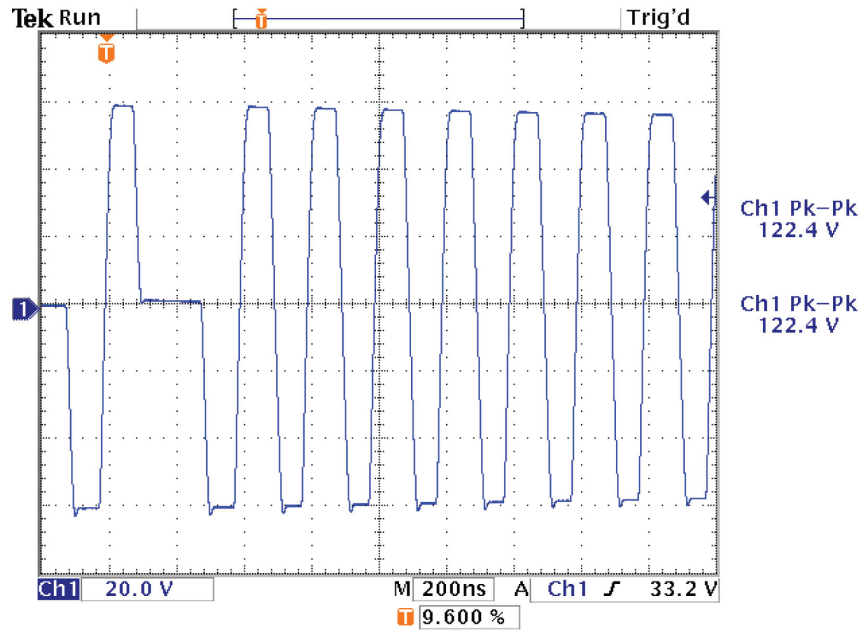

Figure 5. $V_{PP}/V_{NN} = +/-60V$ 5MHz with 330pF//2.5kΩ load and 8-Channel pulsing

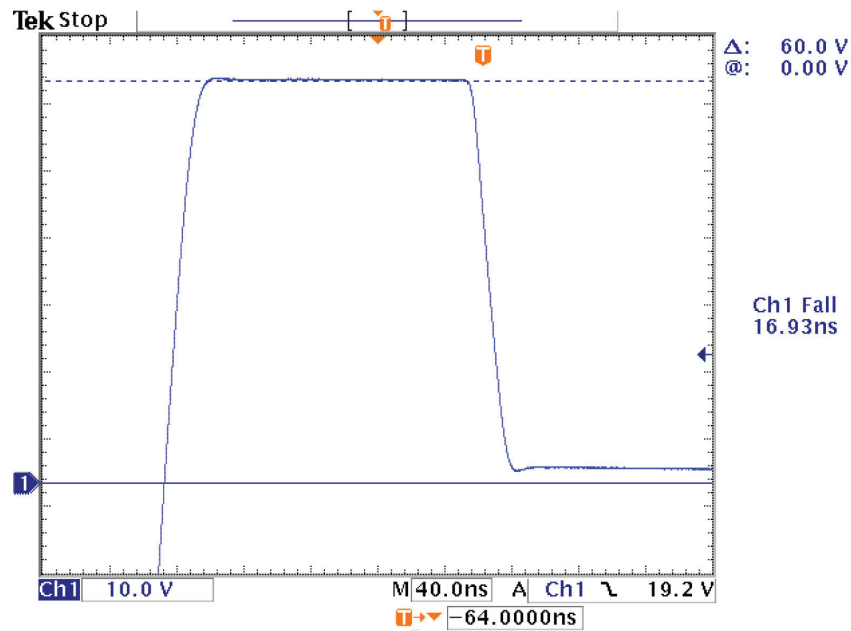

Figure 6. Damping fall time at $V_{PP}/V_{NN} = +/-60V$ with 330pF//2.5kΩ load

Typical Waveforms (cont.)

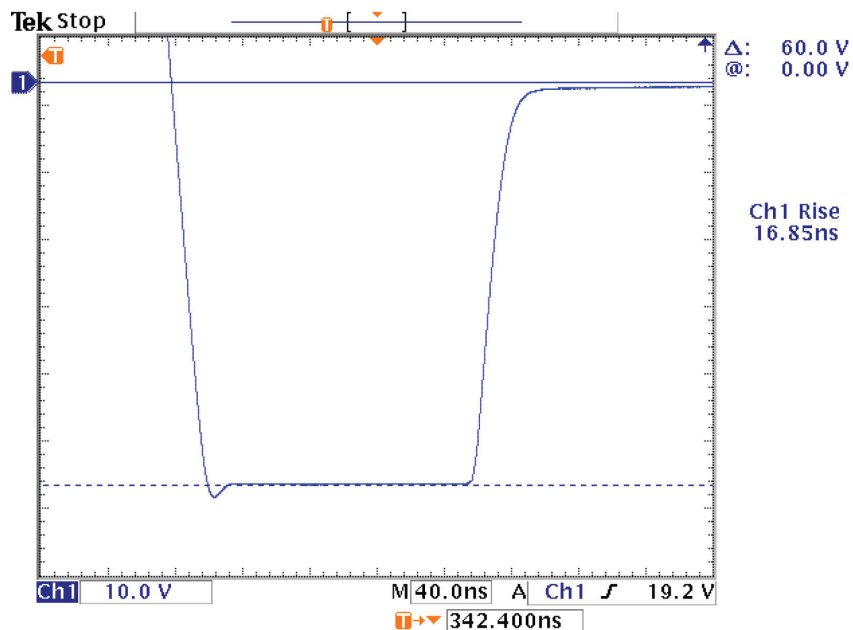

Figure 7. Damping rise time at $V_{PP}/V_{NN} = +/-60V$ with 330pF//2.5kΩ load

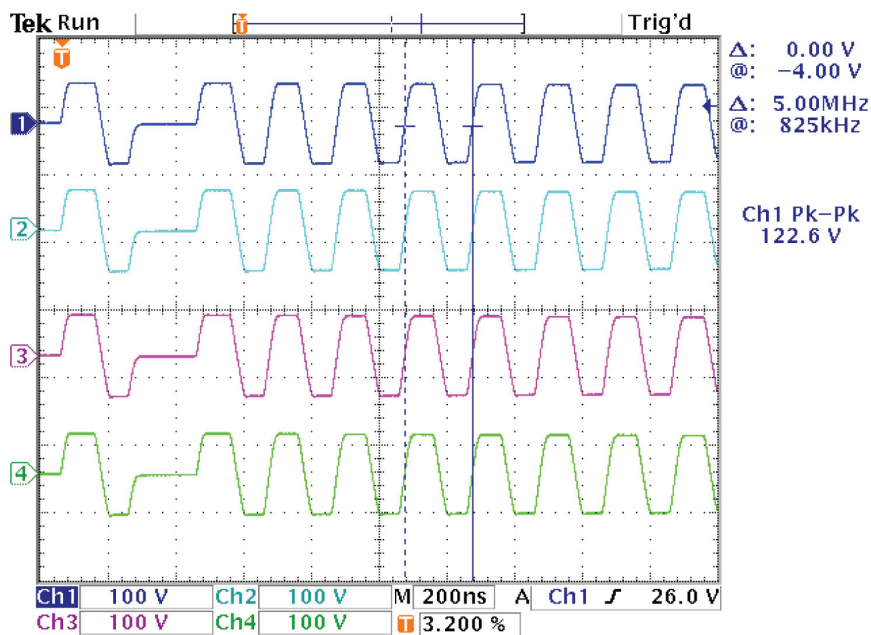

Figure 8. $V_{PP}/V_{NN} = +/-60V$ 5MHz with 330pF//2.5kΩ load 4 of the 8-Channel waveforms shown

Typical Waveforms (cont.)

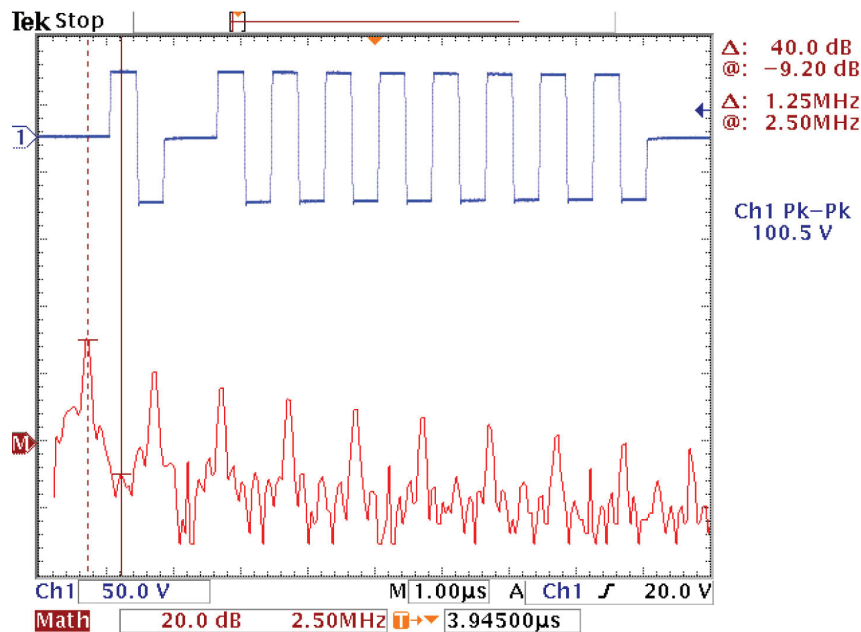

Figure 9. HD2 at $V_{PP}/V_{NN} = +/-50V$ 2.5MHz with 330pF//2.5kΩ load

Bill of Materials

Component	Description	Manufacturer	Part Number
C1 - C3, C18, C19, C22, C25, C30 - C35	CAP CER .22 μ F 16V X7R 10% 0603	TDK	C1608X7R1C224K
C4, C14, C20, C21, C29, C38 - C40	CAP CERC 330PF 200V X7R 0603	Panasonic	ECJ-1VB2D331K
C5, C8, C12, C13, C23, C24, C36, C37	CAP CER 1.0 μ F 16V X7R 0603	TDK	C1608X7R1C105M
C6, C9, C27, C28	CAP CER 1 μ F 100V X7R 20% 1210	TDK	C3225X7R2A105M
D3, D7	LED THIN 635NM RED DIFF 0805 SMD	Lumex	SML-LXT0805IW-TR
D4, D5	LED THIN 585NM YEL DIFF 0805 SMD	Lumex	SML-LXT0805YW-TR
D6	LED THIN 565NM GRN DIFF 0805 SMD	Lumex	SML-LXT0805GW-TR
D16, D17	DIODE SCHOTTKY 100V 1A SMA	Diodes Inc.	B1100-13
D20	DIODE SCHOTTKY DUAL 30V SOT-363	Diodes Inc.	BAT54DW-7
D24 - D31	DIODE SWITCH SS DUAL 70V SOT323	Fairchild	BAV99WT1G
J1	CONN HEADER 2POS .100 VERT GOLD	Molex	22-28-4023
J2	CONN JACK END LAUNCH PCB GOLD SMA	Johnson	142-0711-821
J3	CONN HEADER 6POS .100 VERT GOLD	Molex	22-28-4063
J4	CONN HEADER 10POS .100 VERT GOLD	Tyco	1-640454-0
R2, R9, R12, R18, R23, R53 - R55	Solder Gap (SHORT)	NA	NA
R3, R10, R13, R19, R24, R51, R52, R56	RES 2.55k Ω 1W 1% 2512 SMD	Panasonic	ERJ-1TNF2551U
R4 - R8, R14, R16, R20	RES 1.00k Ω 1/16W 1% 0603 SMD	Panasonic	ERJ-3EKF1001V
R15	RES 49.9 Ω 1/16W 1% 0603 SMD	Panasonic	ERJ-3EKF49R9V
R25, R26, R27, R28, R29	RES 33.2k Ω 1/16W 1% 0603 SMD	Panasonic	ERJ-3EKF3322V
R30, R31	RES 1.00 Ω 1/10W 1% 0603 SMD	Rohm	MCR03EZPFL1R00
R32, R35	RES 10.0 Ω 1/10W 1% 0603 SMD	Panasonic	ERJ-3EKF10R0V
R34, R37, R38, R57	NA	NA	NA
R40, R41, R42, R43, R44	RES 200 OHM 1/16W 1% 0603 SMD	Panasonic	ERJ-3EKF2000V
SW1, SW2, SW3, SW4, SW5	SWITCH LT 4.7MMX3.5MM 100GF SMD	Panasonic	EVQ-P2002M
TP3, TP15	TEST POINT PC MULTI PURPOSE BLK	Keystone	5011
U2	IC CPLD 72 MCELL C-TEMP 44-VQFP	Xilinx	XC9572XL-5VQ44C
U3	IC HV7350K6-G 8-ch RTZ	Supertex Inc.	HV7350K6-G
X1	OSC CLOCK 40.000 MHZ 3.3V SMD	CTS	CB3LV-3C-40.0000-T

Supertex inc. does not recommend the use of its products in life support applications, and will not knowingly sell them for use in such applications unless it receives an adequate "product liability indemnification insurance agreement." **Supertex inc.** does not assume responsibility for use of devices described, and limits its liability to the replacement of the devices determined defective due to workmanship. No responsibility is assumed for possible omissions and inaccuracies. Circuitry and specifications are subject to change without notice. For the latest product specifications refer to the **Supertex inc.** (website: <http://www.supertex.com>)