

The **CMS Series** is a fully compensated, digital I2C and SPI, highly compact pressure-sensor package designed to offer a long term stable high accuracy pressure response.

The CMS Series is a piezoresistive pressure sensor using an ASIC to calibrate and compensate thermal and non-linearity effects. The compact size, excellent burst pressure, wide operation voltage range and low power mode make it very versatile allowing the design of small and low power devices. This device can be used at a wide pressure range, absolute and gage options are available.

COMPANY: Merit Sensor is a leader in piezoresistive pressure sensing and partners with clients to create high performing solutions for a variety of applications and industries.

SENTIUM: Merit Sensor products incorporate a proprietary Sentiium® technology developed to provide a best-in-class operating temperature range and superior stability.

TECHNOLOGY: Merit Sensor utilizes a piezoresistive Wheatstone bridge in a design that anodically bonds glass to a chemically etched silicon diaphragm. All products are RoHS compliant.

CAPABILITIES: Merit Sensor designs, engineers, fabricates, dices, assembles, tests, sells and services die and packaged products from a state-of-the-art facility near Salt Lake City, Utah



FEATURES

- Compact size 6.8mm X 6.8mm
- Wide pressure range options: from 2 to 150PSI
- Pressure Type: Absolute or gage
- Electrical Connection: SMD solder pads, 1.27mm standard spacing
- Output: Digital I2C and SPI
- Burst pressure: 2 to 100 times maximum operating pressure (depending on pressure range)
- Low power mode
- Wide Supply Voltage: 2.7V to 5.5V
- Compensated temperature range: 0C to 50C or -15C to 85C
- Autozero and output signal averaging*

APPLICATIONS

Industrial: Pneumatic systems

Medical: Equipment for diagnosis and analysis

Consumer: Appliances and electronics

Other: Dry non-corrosive gas pressure applications

*For more information about Autozero and output averaging function please contact Merit Sensor.

CMS Series Part Number Configurator

1610-XXXX-XXXX-XXX	
Full Scale Pressure 002 = 2 psi 015 = 15 psi 100 = 100 psi 150 = 150 psi	Electrical Connection 1 = SMD gold plated pads
Pressure Type A = Absolute G = Gage C = Custom D = Differential	Pressure Port 1 = 3X3mm port with gel 2 = 3X3mm port no gel
Calibrated Temperature Range 1 = 0 to 50C - Standard 2 = -15 to 85C - Extended	Accuracy 0 = Standard
Comm. Address¹ 0 = 0x28 1 = 0x48	Calibrated Supply Voltage 1 = 5.2V 2 = 5V 3 = 3.3V 4 = 2.7V
	Output 1 = Digital 10% to 90% ² 2 = Digital 10% to 90% ³

Notes:

¹ Other I2C addresses available upon request

² Start up condition is Sleep Mode (Very Low Power)

³ Start up condition is cyclic Mode

SPECIFICATIONS

Parameter	Minimum	Typical	Maximum	Units	Notes
Electrical					
Supply Voltage (Vs)	2.7		5.5	V	
Supply Current	0.006	3	3.3	mA	Minimum current rated at sleep mode
ESD Protection			4000	V	According to the Human Body Model. As per ASIC's datasheet.
EOC Pin	0		Vs	V	End of conversion. This pin is active for 5us after each new pressure calculation is performed.
Performance					
Output Range (Vout)	10		90	% of counts	2 ²⁴ counts
Resolution	16 (TBD)	18	22 (TBD)	bits	
Startup Time			2.5	ms	Power on to full operation time
Wake Up Time			2	ms	Sleep mode to full operation time
Update Time (digital mode)		5		ms	
Accuracy					
Standard Temperature Range 0 to 50 °C	-1.5%		+1.5%	FSO	Accuracy includes all error for pressure and thermal hysteresis and linearity over the entire operating temperature range. It does not include lifetime drift.
Extended Temperature Range -15 to 0 and 50 to 85	-5%		5%	FSO	
Lifetime Drift	-2		2	%FS	1000 hours @85C
Static Proof Pressure	2.5x			FS	
Burst Pressure	10x			FS	Up to 30PSI parts
Burst Pressure	300			PSI	Above 30PSI parts
Environmental					
Operating Temperature	-40		85	°C	
Storage Temperature	-40		85	°C	
Weight		0.197		g	
Media Type	Dry non-corrosive gases				
Digital Interface (for reference only)					
I ² C™ voltage level HIGH	0.7x		1.0x	Vs	
I ² C™ voltage level LOW	0		0.3x	Vs	
SCL clock frequency			400	kHz	fSCL
SPI Interface Clock	0.05	1	3	MHz	
SPI voltage level High	0.7x		1.0x	Vs	
SPI voltage level LOW	0.0		0.3	Vs	
Delay time [a] between SS-activation edge and first edge of SLCK, MOSI or MISO	1	50		nS	
Delay time [a] between SS- deactivation edge and last edge of SLCK, MOSI or MISO	1	50		nS	
Delay between SS-deactivation edge of last command and of SS-activation edge for next command	10			μS	

I²C TIMING DIAGRAM (FOR REFERENCE ONLY)

PRELIMINARY

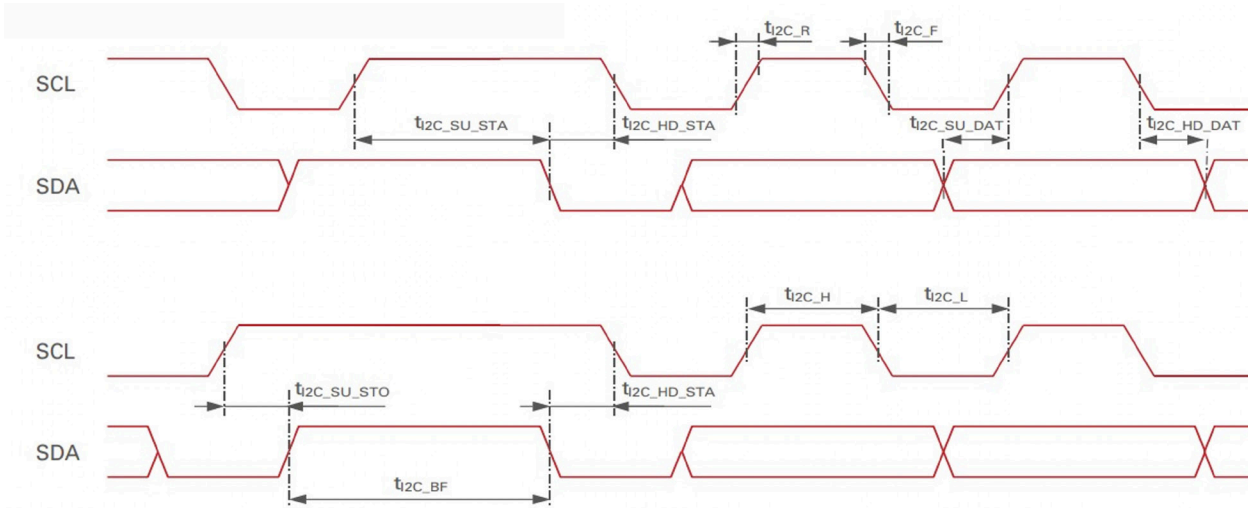

MERIT SENSOR CMS1610 I²C™ COMMUNICATION

- If the part is in sleep/low current mode (see part configurator), the first command regardless of the command type will take part out of sleep once the command has been completed, the part returns to sleep mode. Once the command has been completed, the part returns to sleep mode.

Command Request (IC Write)

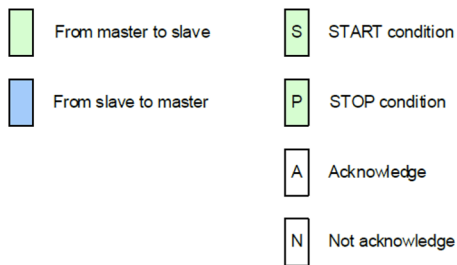
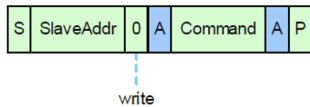

- The following commands are available for the device.
 - 0x00 – Retrieve the serial number followed by a 3 byte read
 - 0xA8 – Start Sleep Mode
 - 0xA9 – Start Command mode (Exit sleep)
 - 0xAB – Start Cyclic Mode
- Please note: writing to any other registers can disable the part or degrade the accuracy
**For more information about Autozero and output averaging function please contact Merit Sensor*

Examples:

If the address of the sensor is 0x28, then to read the serial ID of the sensor unit, use the following command string: **0x00**. The device will respond with its serial number, as shown in the next section, example (a).

Reading data from the sensor. Data will come back in the following format:

Read Data (I2C Read)

(a) Example: after the completion of a Memory Read command

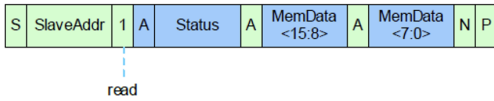

(b) Example: after the completion of a *Measure* command (AA_{HEX})

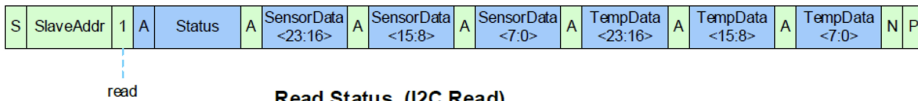

Read Status (I2C Read)

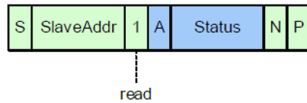

Figure 12. I2C Read Status

**Note: The TempData refers to the internal not calibrated temperature sensor and should not be used as a temperature reference*

- The first Byte (8 bits) returned is the “Status” of the part. It can be decoded in the following manner:

Bit Number	7	6	5	4	3	2	1	0
Meaning	0	Powered	Busy	MODE	MODE	Memory Error	Connection fault	Math Saturation

- MODE meaning (bits 3 & 4):
 - MODE = 00 is Command Mode
 - MODE = 01 is CYCLIC Mode (Bit 5 is also set)
 - MODE = 10 is SLEEP Mode
- All others reserved

SPI COMMUNICATION

SPI Timing Diagram

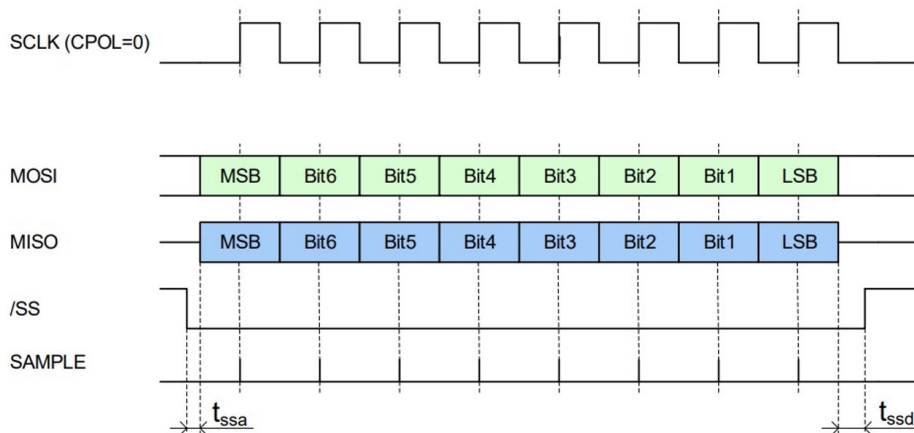

MERIT SENSOR CMS1610 SPI COMMUNICATION

- To start a communication via SPI, the /SS (pin 01) must be at zero, the CMS SPI comm is configured by default for clock polarity and phase = 0 and Slave select = 0
- Upon power up, part will be in sleep/low current mode. Sending the SS pin to zero will take I Mode, each command except NOP is started as shown in below. Note: A command request always the part out of sleep mode into command mode.
- In SPI Mode, each command except NOP is started as shown in below. Note: A command request always consists of 3 bytes. If the command is shorter, then it must be completed with 0 s. The data on MISO depend on the preceding command.

Command Request

MOSI	Command other than NOP	CmdDat <15:8>	CmdDat <7:0>
MISO	Status	Data	Data

- After the execution of a command (busy = 0), the expected data can be read as illustrated below
 - Reading data after a **Memory Read** command:

MOSI	Command = NOP	00 _{HEX}	00 _{HEX}
MISO	Status	MemData <15:8>	MemData <7:0>

- Reading data after a **Measure** command (AA_{HEX})

MOSI	Command = NOP	00 _{HEX}	00 _{HEX}	00 _{HEX}	00 _{HEX}	00 _{HEX}	00 _{HEX}
MISO	Status	SensorData <23:16>	SensorData <15:8>	SensorData <7:0>	TempData <23:16>	TempData <15:8>	TempData <7:0>

*Note: The TempData refers to the internal not calibrated temperature sensor and should not be used as a temperature reference

- If no data are returned by the command, the next command can be sent. The status can be read at any time with the NOP command

Read Status

MOSI	Command = NOP
MISO	Status

TRANSFER FUNCTION FORMULA

$$P_{psi} = (P_{max} - P_{min}) \cdot \left(\frac{P_{counts} - 0.1 \cdot Max}{0.8 \cdot Max} \right) + P_{min}$$

Where

- P = Measured pressure
- P_{counts} = Pressure counts from Merit Sensor part
- P_{min} = Minimum working pressure
- P_{max} = Maximum working pressure
- Max = Maximum output counts@24bits = 16777216

ELECTRICAL

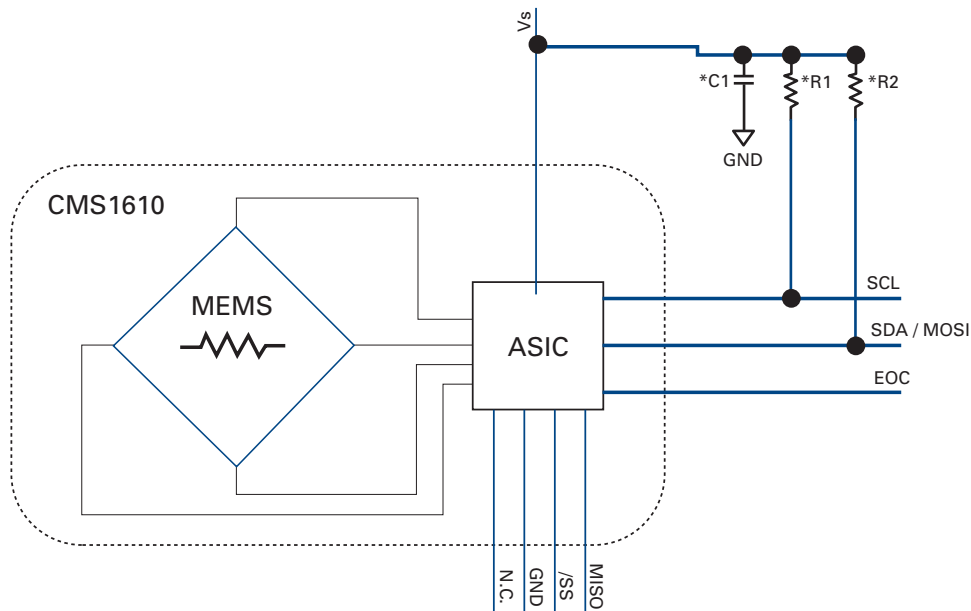

***Notes:**

- A 100nF power supply decoupling ceramic capacitor is recommended. Please install this capacitor as close to the part as possible
- A 3.3k to 10k ohms pull up resistor from SDA and SCL to Vs is required when using I2C communication

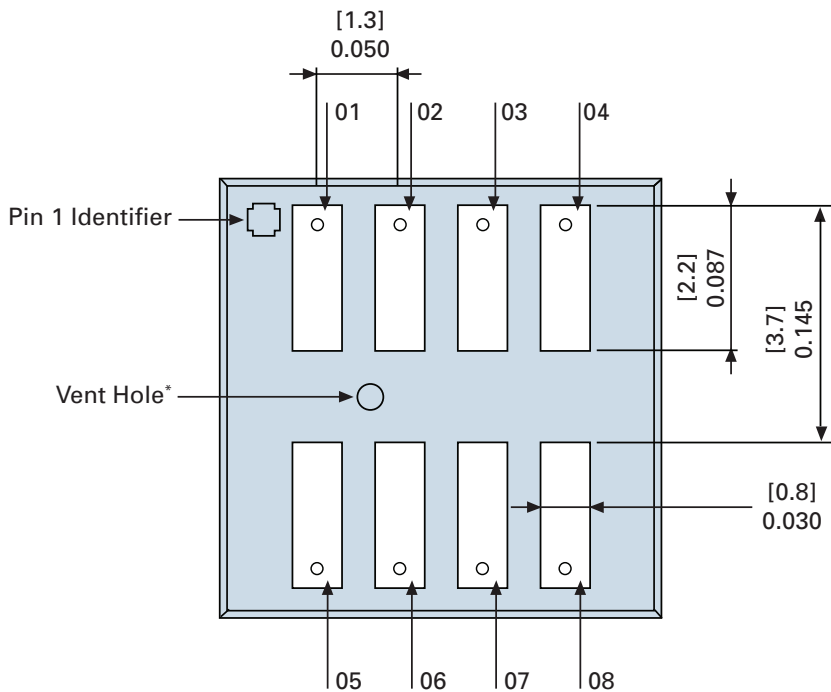

Pin	Function
01	Slave Select (SPI) Active at 0
02	MISO
03	MOSI / SDA
04	SCL
05	Vsupply (2.7~5.5V)
06	GND
07	Do not connect
08	EOC

***Note:**

- Please keep the vent hole unblocked and free of contaminants

DIMENSIONS FOR STANDARD OPTIONS [MM]:

SMD Solder Pads Size: 2.2 X 0.8mm

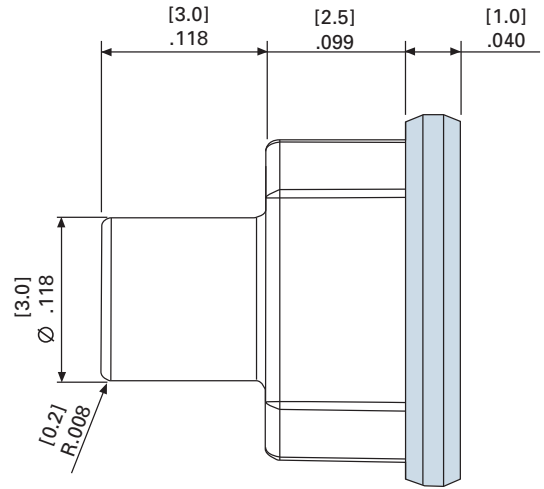
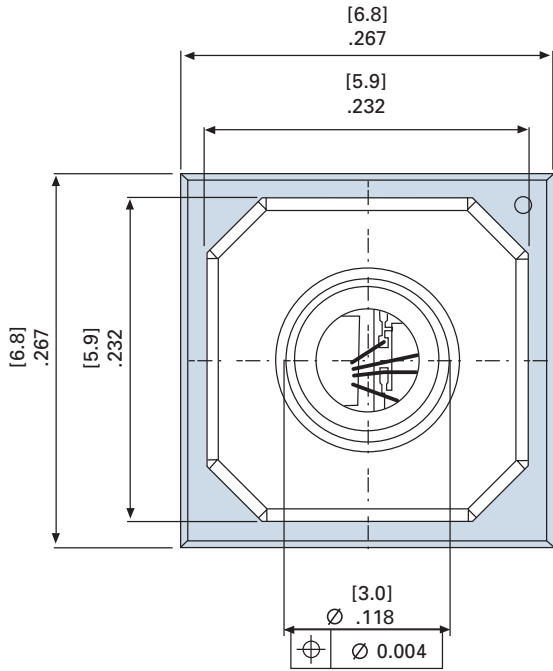

Dimensions for reference only. Engineering drawings (with tolerance) available upon order

PACKAGING AND SHIPPING (TAPE AND REEL)

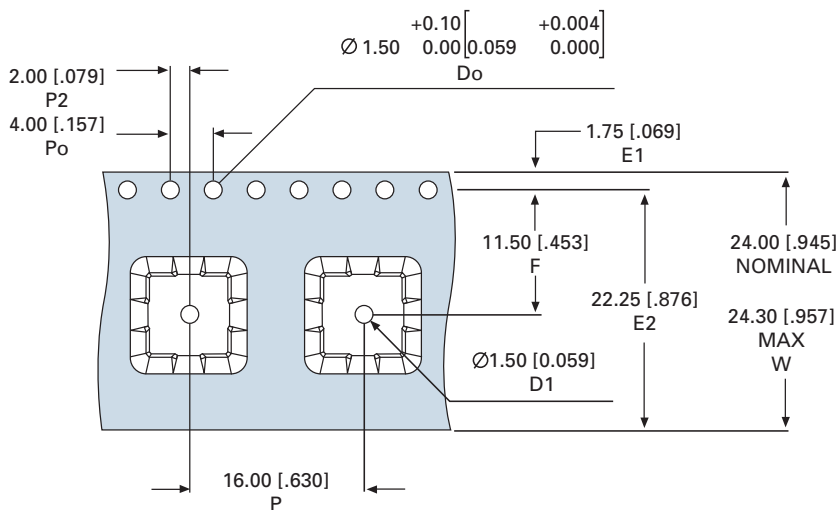

SUGGESTED LAND PATTERN (*FOR REFERENCE ONLY)

Dimensions in mm [inches]

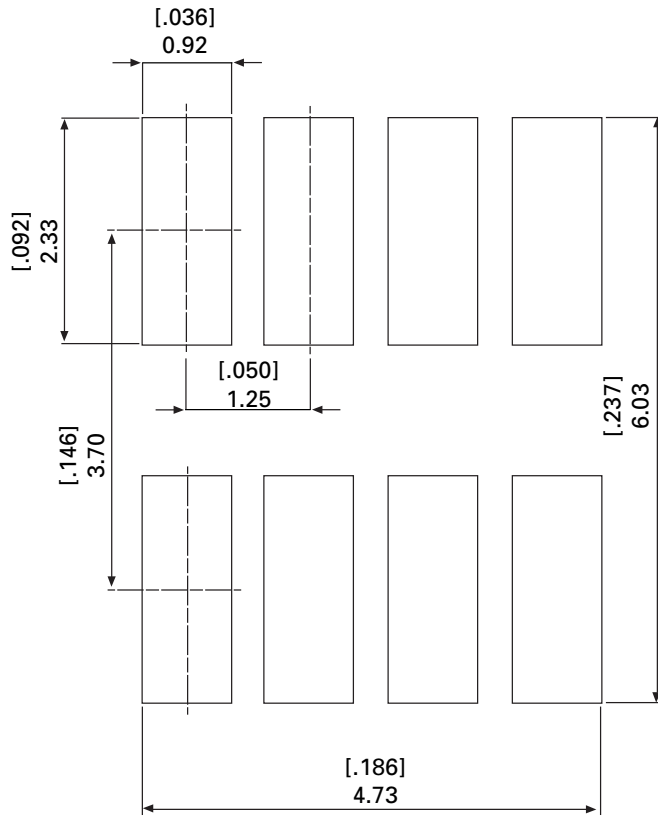

*Note: The land pattern shall be tested on customers application and equipment before used in production



Merit Sensor is based in Salt Lake City, Utah



MERIT SENSOR™

Sales +1 801.208.4722 • Customer Service +1 801.208.4700 • Fax +1 801.208.4798 • sensors@merit.com • www.MeritSensor.com

1600 W. Merit Parkway • South Jordan, Utah • 84095 • USA