

AV-Series

AV/AVH-Series

ANTI-VANDAL PUSHBUTTON SWITCHES

The AV/AVH-Series sealed switch product line features a sleek, stainless design with various LED illumination options. These single pole switches are available with momentary and maintained circuits, with quick connect tab terminals for easy installation and daisy chaining.

The high powered AVH-Series also features ratings up to 30 amps, and safeguards internal switch circuitry with integrated overload protection and thermal cut off, while providing superior safety and performance capabilities. Switching options include ON-OFF, as well as progressive circuits perfectly suited for NAV/ANCHOR functions.

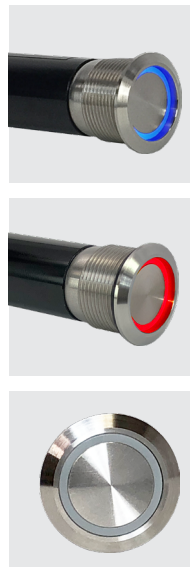

Resources:

[Configure a Complete Part](#)

[Download CAD & Sales Drawing >](#)

[Watch Product Video](#)



Product Highlights:

- Sealed to IP67 for Above-Panel Components
- High Current Ratings
- Momentary and Maintained Circuits
- LED Halo Illumination
- UL1500 Ignition Protection

Typical Applications:

- Marine
- Industrial Controls
- Security Panels
- Public Transit Systems
- Traffic Signals
- Emergency Phones
- Harsh and/or Outdoor Environments



Carling Technologies®

Innovative Designs. Powerful Solutions.

Carling Technologies, Inc.
60 Johnson Avenue, Plainville, CT 06062
Email: sales@carlingtech.com
Application Support: team2@carlingtech.com
Phone: 860.793.9281 Fax: 860.793.9231

www.carlingtech.com

Electrical

Contact Rating	10.1A Resistive @ 12VDC
LED Rating	12 VAC/DC @ 15mA
Dielectric Strength	1000V RMS 50~60 Hz
Insulation Resistance	50 M-ohms min. @ 500VDC
Initial Contact Resistance	≤10 mΩ
Electrical Endurance	Up to 25K Cycles
Contacts	Silver alloy
Terminals	.110" x 0.020 [2.79 x 0.5 mm] plug-in terminal, copper alloy silver plate.

Physical

Function	NO / NC contact (changeover)
Operation	Momentary or maintained
Illumination	Independent LED
Seals	Silicone, Bezel and Button
Mounting	M19-P1.0 Nut (SUS316), Tightening torque: 2~3Nm.
Base	Glass filled Nylon
Actuator	Stainless Steel 316
Lens	Polycarbonate, PC
Bushing	Stainless Steel 316
Actuation Force	7N max
Weight	18g

Environmental

Storage Temperature	-55°C to +85°C
Operating Temperature	-30°C to +70°C (may affect endurance)
Vibration, High Frequency	Mil-Std 202G, Method 204D, Test Condition A 0.06 DA or 10G ¹ s 10-500 Hz. Test criteria- No loss of circuit during test and pre and post test contact resistance.
Vibration, Random	Mil-Std 202G, Method 214A, Test Condition I and B 7.56G ¹ s RMS. 8-hours in each of the 3 mutually perpendicular axes. Test criteria- No loss of circuit during test and pre and post test contact resistance.
Thermal Shock	MIL-STD 202G Method 107G, Condition A (Five cycles @ -55°C to +25°C to +85°C to +25°C)
Moisture Resistance	MIL-STD 202G Method 106G, i.e. 10~24-hour cycles @ +25°C to +60°C, 80-90% RH.
Sealing	IP67, for above-panel components of the actual switch; compliant with IEC 60529.
Ignition Protection	UL1500, ISO 8846, SAE J1171
Electro-Static Discharge	Compliant with EN61000-4-2 Discharge Level: Max. ±8KV; Discharge Level: Max. ±15KV

*Manufacturer reserves the right to change product specification without prior notice.

GPS-0003 Rev: B



1 SERIES
AV Anti-Vandal Pushbutton Switch

2 MOUNTING
1 M19 Threaded Bushing

3 MATERIAL / FINISH
1 Stainless Steel Bushing / Button

4 CIRCUIT
A Momentary NC / NO **B** Maintained NC / NO

5 RATING
2 10.1A Resistive, 12VDC

6 TERMINATION
1 .110" Quick Connect Tabs - Silver Plated

7 LENS / BUTTON
1 Flush

8 LED COLOR
N No LED **B** Green **D** White
A Red **C** Amber **E** Blue

9 ILLUMINATION STYLE
N None **R** Ring

10 LEGEND

00 No Legend

01 On/Off 	02 Stand By 	03 Light 	04 Bell
05 Door Open 	06 Information 	07 Horn 	

Dimensional Specifications: in. [mm]

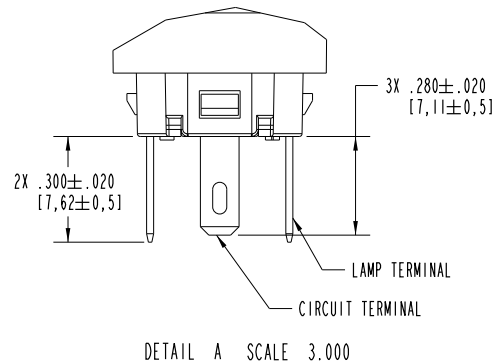
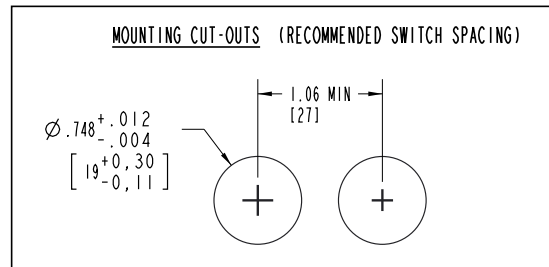
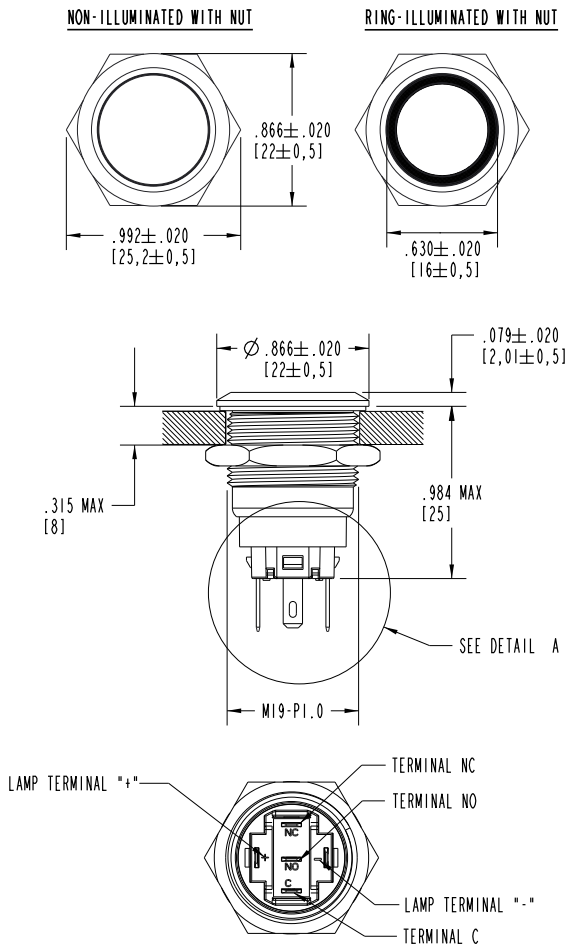

AVH-Series**Electrical**

Supply Voltage Range	9VDC – 16VDC
Overtemp. Protection	≥150°C (SmartFET temperature), Latched status signal
Reverse Polarity Protection	16 VDC
Insulation Resistance	50 M-ohms min. @500VDC
Initial Contact Resistance	≤10 mΩ
Electrical Endurance	Up to 50K Cycles

Circuit B (High-Current Latching)

Current Rating	20A 12VDC, 80A surge (300 ms), 14 AWG lead wire 30A 12VDC, 100A surge (300 ms), 12 AWG lead wire
Function	ON / OFF
Overload Protection	≥135A, Output does not function. Switch is reset by cycling through OFF position (unless overload continues).
Connections	14AWG, 12 AWG Lead Wire (20A, 30A, respectively), 6" Lg. 0.187" PC Quick Connect Terminal Ground Connection.

Circuit C (Nav-Anchor)

Current Rating	10A total, 5A each Output; 10A surge each Output (300 ms)
Function	NAV-ANC, First press: Load 1 ON & Load 2 ON, Red Ring Illuminated Second press: Load 1 ON, Load 2 OFF, Blue Ring Illuminated Third Press: OFF
Overload Protection	≥60A, Output does not function Switch reset by cycling through OFF position (unless overload continues).
Connections	16AWG, 5A per Output, 6" Lg. 0.187" PC Quick Connect Terminal Ground Connection.

Circuit D (Dual-Output)

Current Rating	10A total, 5A each Output; 10A surge each Output (300 ms)
Function	First press: OFF Second press: Load 1 ON, Load 2 OFF, Red Ring Illuminated Third Press: Load 1 OFF, Load 2 ON, Blue Ring Illuminated.
Overload Protection	≥60A, Output does not function Switch reset by cycling through OFF position (unless overload continues).
Connections	16AWG, 5A per Output, 6" Lg. 0.187" PC Quick Connect Terminal Ground Connection.

Physical

Operation	Push button, Momentary (Circuit C & D), Maintained (Circuit B)
Illumination	Dependent LED
Seals	Gasket, bezel silicone, potted housing
Mounting	M19-P1.0 Nut, Tightening torque: 2~3Nm
Housing	Aluminum 6061 T6, Anodized per MIL-STD-8625, Type II, Class 2; Black
Actuator	Stainless steel 316
Lens	Polycarbonate, PC
Bushing	Stainless steel 316
Actuation Force	7N max
Weight	45-50g

Environmental

Storage Temperature	-55°C to +85°C
Operating Temperature	-30°C to +70°C (may affect endurance)
Vibration	Mil-Std 202G, Method 204D, Test Condition A 0.06 DA or 10G' s 10-500 Hz. Test criteria - No loss of circuit during test and pre and post test contact resistance.
Vibration, Random	Mil-Std 202G, Method 214A, Test Condition I and B 7.56G' s RMS. 8-hours in each of the 3 mutually perpendicular axes. Test criteria - No loss of circuit during test and pre & post test contact resistance.
Shock	Mil-Std 202G, Method 213B, Test Condition K @ 30g's, 11ms normal duration. No resistance value loss pre and post test and no function malfunction. No loss of contact or unintended contact making.
Thermal Shock	MIL-STD 202G Method 107G, Condition A (Five cycles @ -55°C to +25°C to +85°C to +25°C)
Moisture Resistance	MIL-STD 202G Method 106G, i.e. 10~24-hour cycles @ +25°C to +60°C, 80-90% RH.
Sealing	IP67, for above-panel components of the actual switch compliant with IEC 60529.
Ignition Protection	UL1500, ISO 8846, SAE J1171

*Manufacturer reserves the right to change product specification without prior notice.
GPS-0019 Rev: A



1 SERIES
AVH Anti-Vandal High Current Pushbutton Switch

2 MOUNTING
1 M19 Threaded Bushing

3 MATERIAL / FINISH
1 Stainless Steel Bushing / Button

4 CIRCUIT 1, 2
B ON - OFF (Output 1 - None) Maintained
C ON - ON - OFF (Output 1&2 - Output 1 - None) Momentary
D OFF - ON - ON (None - Output 1 - Output 2) Momentary

5 RATING 3
1 30A 12VDC
2 20A 12VDC
3 5A 12VDC (Per Output) / 10A 12VDC (Total)

6 WIRE LENGTH
6 6 inches (152.4 mm) with 0.187" (4.8mm) Ground Tab Terminal

7 ILLUMINATION STYLE 4
N None **R** Ring

8 POSITION 1 LED COLOR
N No LED **B** Green **D** White
A Red **C** Amber **E** Blue

9 POSITION 2 LED COLOR 5, 6
N No LED **E** Blue

10 ILLUMINATION TYPE 7
N None
A Dependent (LED illuminates when the specified output is "ON")

- Notes:
 1 Circuit code B requires rating code 1 or 2 only.
 2 Circuit codes C & D require rating code 3.
 3 Rating will determine the wire gauge used.
 4 Illumination Style code N requires: Position 1 LED Color N; Position 2 LED Color code N; Illumination Type code N.
 5 Circuit codes C & D require Position 2 LED color E.
 6 Circuit code B requires Position 2 LED Color code N.
 7 Other lighting options available: Consult Manufacturer.

Dimensional Specifications: in. [mm]

NON-ILLUMINATED WITH NUT

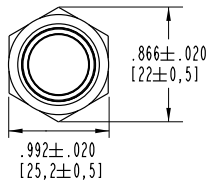

RING-ILLUMINATED WITH NUT

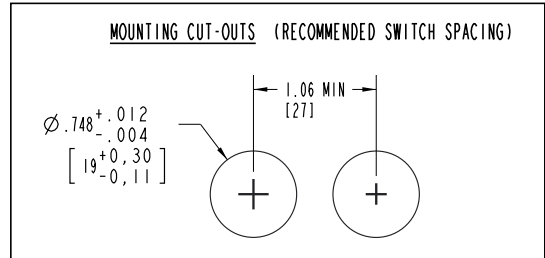

CIRCUIT B

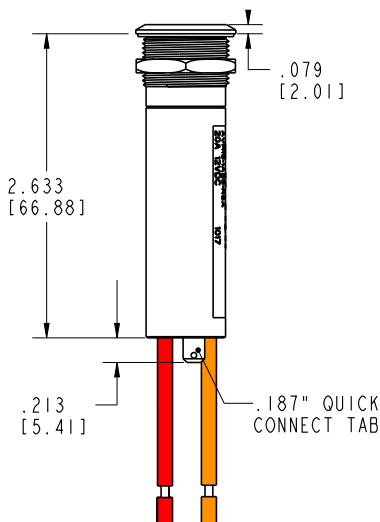

CIRCUIT C

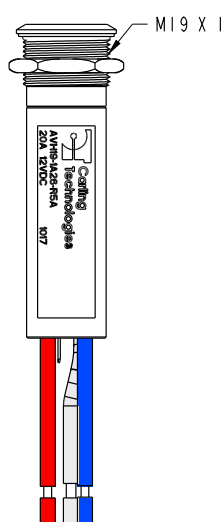

CIRCUIT D

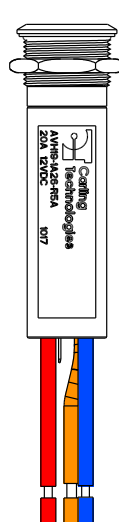

CIRCUIT B: BATTERY(+): RED WIRE
 LOAD 1: ORANGE WIRE
 GROUND: TAB OR BLACK

CIRCUIT C: BATTERY(+): RED WIRE
 LOAD 1: BLUE WIRE
 LOAD 2: WHITE WIRE
 GROUND: TAB

CIRCUIT D: BATTERY(+): RED WIRE
 LOAD 1: BLUE WIRE
 LOAD 2: ORANGE WIRE
 GROUND: TAB

Authorized Sales Representatives and Distributors

Click on a region of the map below to find your local representatives and distributors or visit www.carlingtech.com/findarep.



About Carling

Founded in 1920, Carling Technologies is a leading manufacturer of electrical and electronic switches and assemblies, circuit breakers, electronic controls, power distribution units, and multiplexed power distribution systems. With four ISO9001 and IATF16949 registered manufacturing facilities and technical sales offices worldwide, Carling Technologies Sales, Service and Engineering teams do much more than manufacture electrical components, they engineer powerful solutions! To learn more about Carling please visit www.carlingtech.com/company-profile.

To view all of Carling's environmental, quality, health & safety certifications please visit www.carlingtech.com/environmental-certifications

Worldwide Headquarters

Carling Technologies, Inc.
60 Johnson Avenue, Plainville, CT 06062
Phone: 860.793.9281 **Fax:** 860.793.9231
Email: sales@carlingtech.com

Northern Region Sales Office: nrsm@carlingtech.com
Southeast Region Sales Office: sersm@carlingtech.com
Midwest Region Sales Office: mrrsm@carlingtech.com
West Region Sales Office: wrsm@carlingtech.com
Latin America Sales Office: larsm@carlingtech.com

Asia-Pacific Headquarters

Carling Technologies, Asia-Pacific Ltd.,
Suite 1607, 16/F Tower 2, The Gateway,
Harbour City, 25 Canton Road,
Tsimshatsui, Kowloon, Hong Kong
Phone: Int + 852-2737-2277 **Fax:** Int + 852-2736-9332
Email: sales@carlingtech.com.hk

Shenzhen, China: shenzhen@carlingtech.com
Shanghai, China: shanghai@carlingtech.com
Pune, India: india@carlingtech.com
Kaohsiung, Taiwan: taiwan@carlingtech.com
Yokohama, Japan: japan@carlingtech.com

Europe | Middle East | Africa Headquarters

Carling Technologies LTD
4 Airport Business Park, Exeter Airport,
Clyst Honiton, Exeter, Devon, EX5 2UL, UK
Phone: Int + 44 1392.364422 **Fax:** Int + 44 1392.364477
Email: ltd.sales@carlingtech.com

Germany: gmbh@carlingtech.com
France: sas@carlingtech.com



Carling Technologies®

Innovative Designs. Powerful Solutions.